

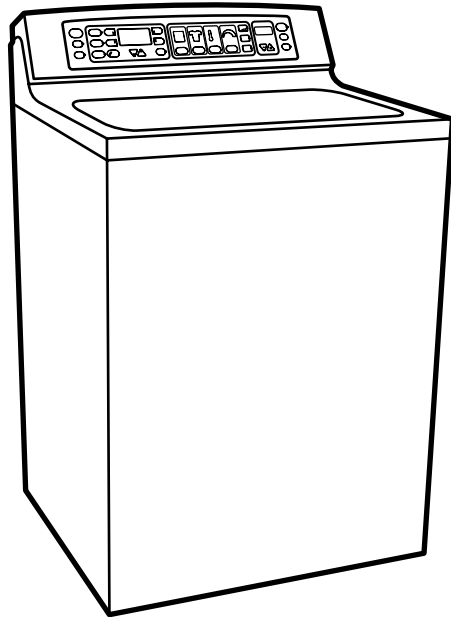

TECHNICAL SERVICE GUIDE

Profile Stainless Steel Washer



MODEL SERIES:

WPRB9250

WPRB9220





IMPORTANT SAFETY NOTICE

The information in this service guide is intended for use by individuals possessing adequate backgrounds of electrical, electronic, and mechanical experience. Any attempt to repair a major appliance may result in personal injury and property damage. The manufacturer or seller cannot be responsible for the interpretation of this information, nor can it assume any liability in connection with its use.

WARNING

To avoid personal injury, disconnect power before servicing this product. If electrical power is required for diagnosis or test purposes, disconnect the power immediately after performing the necessary checks.

RECONNECT ALL GROUNDING DEVICES

If grounding wires, screws, straps, clips, nuts, or washers used to complete a path to ground are removed for service, they must be returned to their original position and properly fastened.

GE Consumer Home Services Training

Technical Service Guide

Copyright © 2002

All rights reserved. This service guide may not be reproduced in whole or in part in any form without written permission from the General Electric Company.

Table of Contents

Accelerometer	30
Agitator	19
Automatic Temperature Control (ATC)	24
Choke	27
Component Locator Views	15
Control Clothes Care Cycles	5
Control EMI Filter	27
Control Features	4
Control One Touch Selections	9
Control Panel	16
Control Quick Start Selections	7
Cover/Lid Assembly	17
Cycle Charts	12
Cycle Options	10
Cycle Status	11
Drain Pump	18
Drive Belt	18
Electronic Control Board	26
Error Codes	40
Flood Protection	11
Front Panel	17
Inverter	29
Leveling Legs	16
Lid Lock	23
Lid Switch	22
Lid Switch Diagnostics	23
Motor	28
Motor Tachogenerator Test	32
Nomenclature	2
Problem Chart	46
Schematic	47
Serial Number	2
Service Mode	34
Speed Sensor	29
Spin Basket	19
Suspension	20
Transmission	21
Troubleshooting Guide	42
Tub With Motor and Transmission	22
Warranty	3
Water Level (Load Size) Diagnostics	25
Water Level Switch	25
Water Valve	24

Nomenclature

W H S B 9 0 0 0 B 0 W W

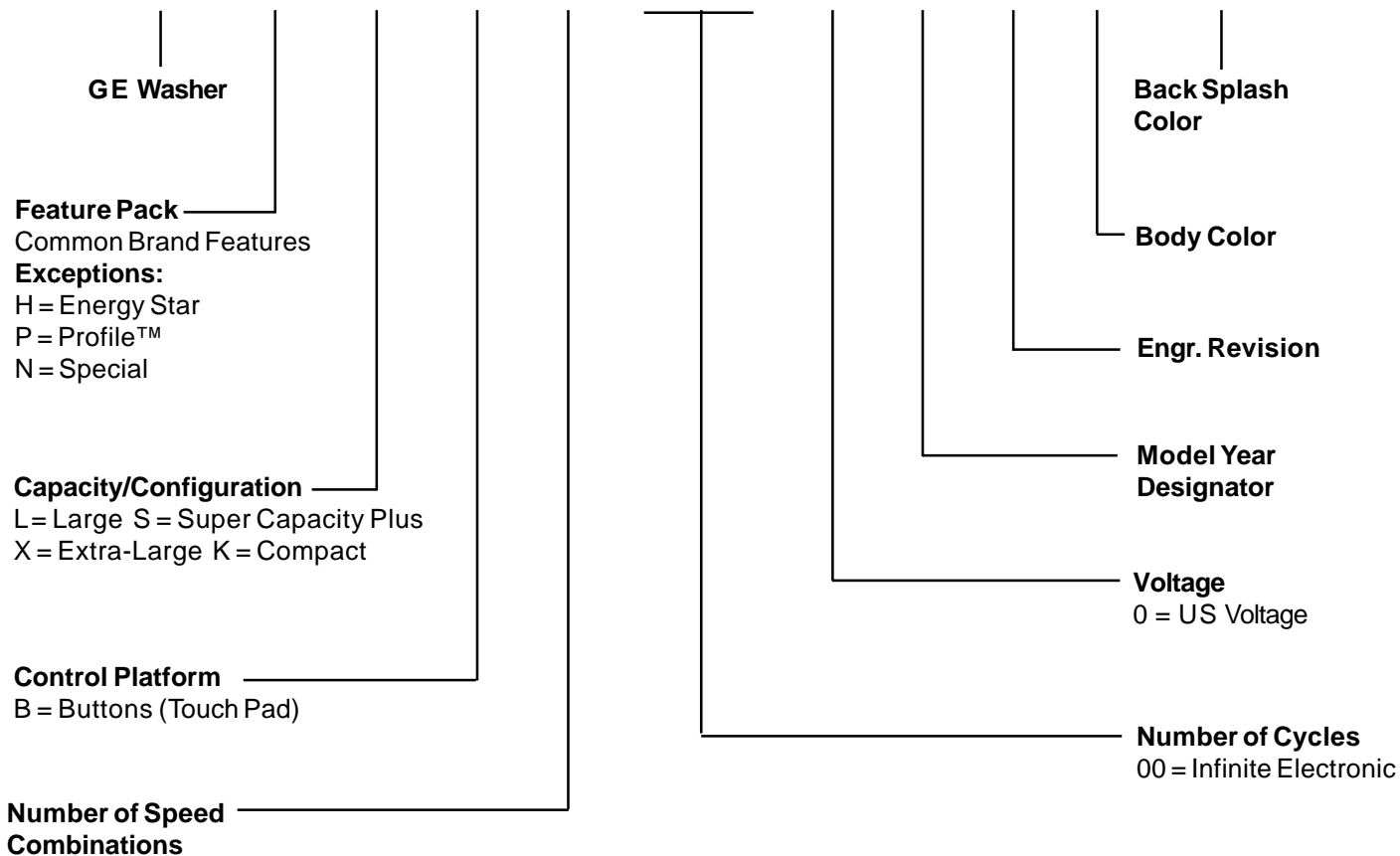

Serial Number

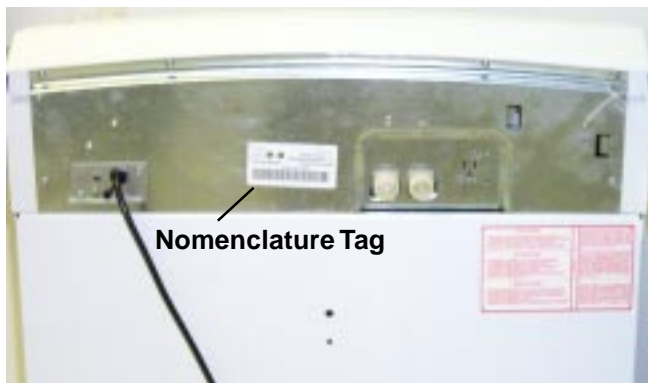

The first two characters of the serial number identify the month and year of manufacture.

Example: AD123456S = January, 2002

A - JAN	2005 - H
D - FEB	2004 - G
F - MAR	2003 - F
G - APR	2002 - D
H - MAY	2001 - A
L - JUN	2000 - Z
M - JUL	1999 - V
R - AUG	1998 - T
S - SEP	1997 - S
T - OCT	1996 - R
V - NOV	1995 - M
Z - DEC	1994 - L

The letter designating the year repeats every 12 years.

Example:
T - 1974
T - 1986
T - 1998

Note: Model number and serial number are located on rear of backsplash.

- The technical sheet is located inside the control panel.

Warranty

GE Washer Warranty



All warranty service provided by our Factory Service Centers, or an authorized Customer Care® technician. To schedule service, on-line, 24 hours a day, visit us at GEAppliances.com, or call 800.GE.CARES (800.432.2737).

For The Period Of:	We Will Replace:
One Year From the date of the original purchase	Any part of the washer which fails due to a defect in materials or workmanship. During this full one-year warranty , GE will also provide, free of charge , all labor and in-home service to replace the defective part.
Two Years From the date of the original purchase	Any part of the washer which fails due to a defect in materials or workmanship. During this additional one-year limited warranty , you will be responsible for any labor or in-home service costs.
Five Years From the date of the original purchase	The suspension rod and spring assembly and electronics , if any of these parts should fail due to a defect in materials or workmanship. GE will also replace the washer lid or cover , if they should rust under operating conditions. During this additional four-year limited warranty , you will be responsible for any labor or in-home service costs.
Ten Years From the date of the original purchase	The transmission and outer washer tub , if any of these parts should fail due to a defect in materials or workmanship. During this additional nine-year limited warranty , you will be responsible for any labor or in-home service costs.
Lifetime From the date of the original purchase	The washer basket , if it should fail due to a defect in materials or workmanship. During this lifetime limited warranty , you will be responsible for any labor or in-home service costs.

What Is Not Covered:

- Service trips to your home to teach you how to use the product.
- Improper installation.
- Failure of the product if it is abused, misused, or used for other than the intended purpose or used commercially.
- Replacement of house fuses or resetting of circuit breakers.
- Damage to the product caused by accident, fire, floods or acts of God.
- Incidental or consequential damage caused by possible defects with this appliance.

This warranty is extended to the original purchaser and any succeeding owner for products purchased for home use within the USA. In Alaska, the warranty excludes the cost of shipping or service calls to your home.

Some states do not allow the exclusion or limitation of incidental or consequential damages. This warranty gives you specific legal rights, and you may also have other rights which vary from state to state. To know what your legal rights are, consult your local or state consumer affairs office or your state's Attorney General.

Warrantor: General Electric Company, Louisville, KY 40225

Control Features

WPRB9250

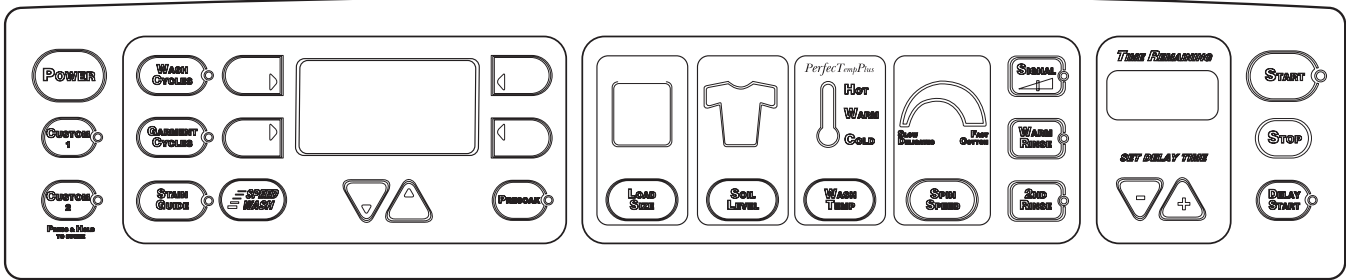

WPRB9220

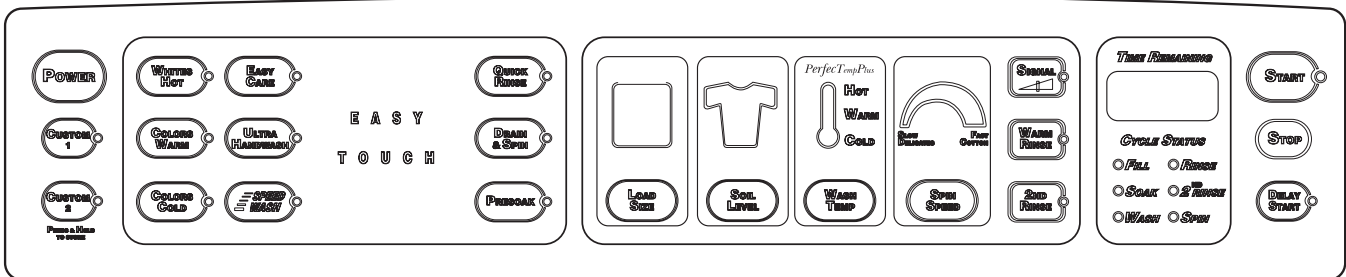



START

- After you have selected a new cycle, press once to start the cycle.
- Press twice to select the last cycle used and start the washer.
- If the washer is running, press once to pause the cycle; press again to continue the cycle.



STOP

If the washer is running, press once to pause the cycle; press again to cancel the cycle.

TIME REMAINING



Time Remaining

- Displays the approximate time remaining until the end of the cycle, or the time remaining for **DELAY START**.
- Cycle time is affected by how long it takes the washer to fill. This depends on the water pressure in your home. The “smart” timer “learns” the amount of time it takes to fill your washer and adjusts the total time accordingly.

Clothes Care Cycles



PRESOAK

To presoak a load and go straight into a wash cycle:

Select your wash cycle, press the **PRESOAK** pad, then press the **START** pad.

- Each time you press **PRESOAK**, you will add three minutes of agitation, followed by 12 minutes of soaking, for up to an hour of additional time. After the final soak period, the selected wash cycle begins.
- Uses the speed and water temperature of your selected wash cycle.



QUICK RINSE

Use this feature to quickly rinse chlorine, perspiration, stains, etc. out of clothes.

- The washer fills with water, agitates for three minutes, drains and spins. You may change the automatic settings if desired.

*On some models, **QUICK RINSE** is found under the **WASH CYCLES** menu.*



SPEED WASH

For lightly soiled items that are needed in a hurry. Cycle time is approximately 20 minutes, depending on your household water pressure.

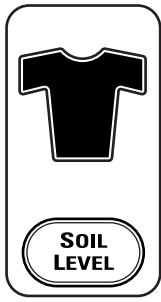

SOIL LEVEL

The **SOIL LEVEL** setting determines the amount of agitation time.

The highest **SOIL LEVEL** is the Stain Wash cycle, which adds a 30 minute soak and agitation at the beginning of the selected wash cycle.



DRAIN & SPIN

You can drain and spin any cycle at any time.

On models with a **DRAIN & SPIN** pad, press to drain and spin.

On models without a **DRAIN & SPIN** pad, press **START** to pause the washer, select **DRAIN & SPIN** from the **WASH CYCLES** menu, then press **START** again.



CUSTOM 1 and CUSTOM 2 (on some models)

Set up your favorite combination of settings and save them here for one-touch recall.

These custom settings cannot be set while a cycle is in progress.

To store a custom combination of settings:

1. Select an **EASY TOUCH** setting.
2. Change **LOAD SIZE**, **SOIL LEVEL**, **WASH TEMPERATURE** or **SPIN SPEED** to fit your needs.
3. Select any **OPTIONS** you want.
4. Press and hold the **CUSTOM 1** or **CUSTOM 2** pad until the washer beeps to store your selection.

To recall your stored combination:

Press the **CUSTOM 1** or **CUSTOM 2** pad, then press **START**.

To reprogram the custom settings:

Repeat steps 1–4 above.

Control Quick Start Selections (Model 9250)

- 1 Add detergent.

Add diluted fabric softener (on models with a fabric softener dispenser).

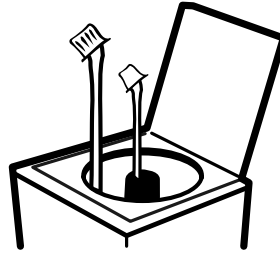

- 2 Loosely load clothes no higher than the top row of holes in the washer basket. The water level should just cover the clothes.

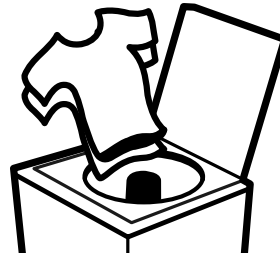

- 3 Select one of the three wash methods:
- Press **WASH CYCLES** to wash according to **load type**
 - Press **GARMENT CYCLES** to wash according to **clothing type**
 - Press **STAIN CYCLES** to wash clothes with specific types of **stains**

The **STAIN CYCLES** will provide you with tips on pretreating your stain and will then automatically select the washer settings for the optimum cycle to remove the stain.

Select the wash, garment or stain cycle by pressing the arrow pads (◀▶) at the sides of the display. You can scroll up and down through the list of cycles by pressing the **UP** (▲) and **DOWN** (▼) arrow pads beneath the display.

NOTE: Any time you make a selection that is incompatible with the chosen wash cycle, the washer will beep twice.

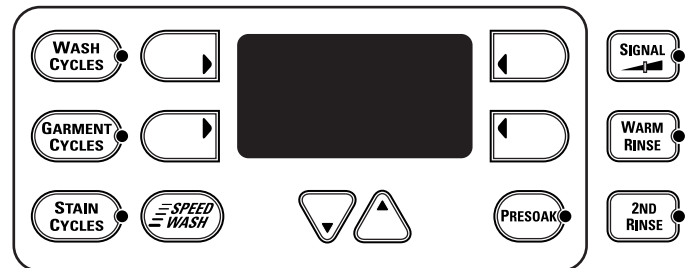

- 4 Change any of the automatic settings, if desired, by pressing the pad beneath the setting.

Higher settings will:

- Fill the washer basket with more water
- Remove heavier soil. The highest level is the Stain Wash cycle, with a 30 minute soak and agitation at the beginning of the wash cycle.
- Add cold, warm or hot water
- Spin faster to remove more water for shorter drying times

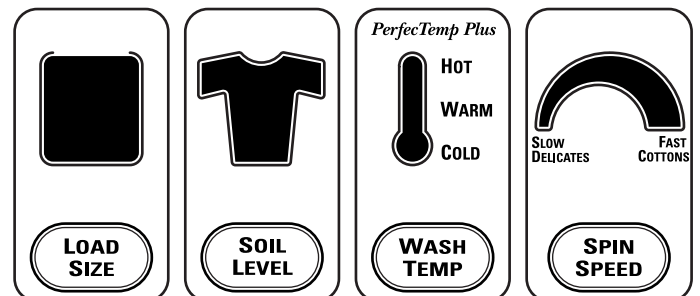

- 5 Close the lid and press **START**.



Control Quick Start Selections (Model 9220)

1 Add detergent.

Add diluted fabric softener (on models with a fabric softener dispenser).

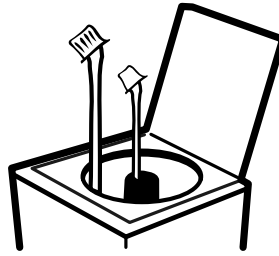

2 Loosely load clothes no higher than the top row of holes in the washer basket. The water level should just cover the clothes.

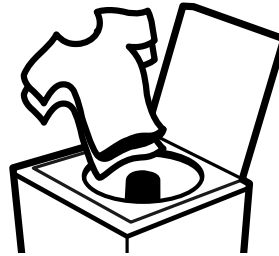

3 Select the wash cycle and other wash options.

NOTE: Any time you make a selection that is incompatible with the chosen wash cycle, the washer will beep twice.

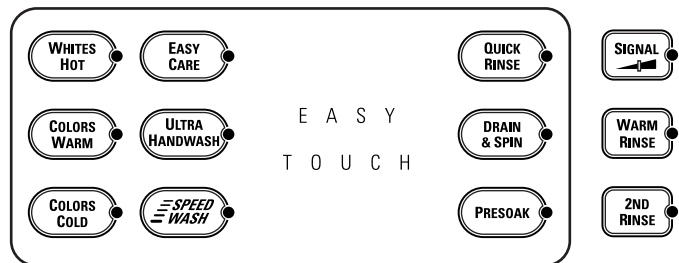

4 Change any of the automatic settings, if desired, by pressing the pad beneath the setting. Higher settings will:

- Fill the washer basket with more water
- Remove heavier soil. The highest level is the Stain Wash cycle, with a 30 minute soak and agitation at the beginning of the wash cycle.
- Add cold, warm or hot water
- Spin faster to remove more water for shorter drying times

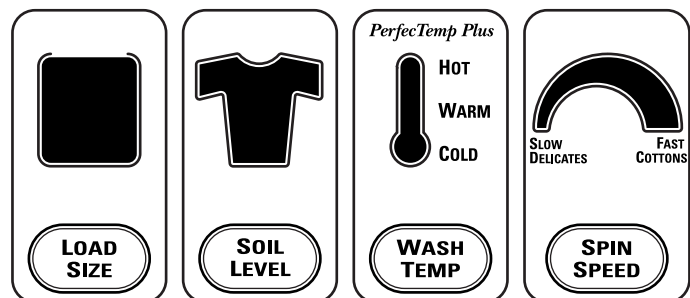

5 Close the lid and press **START**.



Control One Touch Selections (Model 9250)



WASH CYCLES

The **Wash Cycles** are optimized according to load type. The chart below will help you match the wash cycle setting with your clothing.

Cycle	Wash Speed	Description
WHITES	Fast	For heavy to lightly soiled white cottons, household linens, work and play clothes.
COLORS	Fast	For heavy to lightly soiled colorfast cottons, household linens, work and play clothes.
DARK COLORS	Medium	For non-colorfast cottons and blends, and items that are labeled cold wash by the fabric manufacturer.
EASY CARE	Medium	For wrinkle-free and permanent press items.
CASUALS	Medium	For wrinkle-free and permanent press items. Provides agitate/pause cycles to clean your items.
KNITS	Medium	Specially designed for normally soiled knits.
DELICATES	Slow	For lingerie and special-care fabrics with light to normal soil. Provides periods of agitation and soak during wash and rinse.
ULTRA HANDWASH	Very Slow	For items labeled hand-washable with light soils. Provides periods of agitation and soak during wash and rinse.
QUICK RINSE	Medium	For quickly rinsing chlorine, perspiration, stains, etc. out of clothes.
DRAIN & SPIN	Spin Only	Drain and spin any cycle at any time.
SOAK	Medium	Provides a soak of up to 24 hours. The washer will drain and spin at the end of the cycle.
SPEED WASH	Medium Fast	For lightly soiled items that are needed in a hurry. Cycle time is approximately 20 minutes, depending on your household water pressure.



GARMENT CYCLES

The **Garment Cycles** are customized to provide optimum washing for a variety of fabrics and clothing types.

Garment Cycles include:

- *Jeans*
- *Underwear*
- *Towels*
- *Infant Wear*
- *Khakis*
- *Play Clothes*
- *Mats/Rugs*
- *Lingerie*
- *Dress Shirts*
- *Everyday Wear*
- *Sheets*
- *Silks/Linen*
- *Knit Shirts*
- *Athletic Wear*
- *Table Linen*







STAIN CYCLES

The **Stain Cycles** are customized to provide optimum washing for specific types of stains. Press **STAIN CYCLES**, select the specific stain and follow the on-screen instructions. Stain selections include:

- | | | | |
|----------------------|--------------------------|-----------------------|----------------------|
| Food Stains | Body Stains | Outdoor Stains | Drink Stains |
| ■ <i>Catsup</i> | ■ <i>Dingy Whites</i> | ■ <i>Grass</i> | ■ <i>Milk</i> |
| ■ <i>Chocolate</i> | ■ <i>Perspiration</i> | ■ <i>Grease</i> | ■ <i>Coffee/Tea</i> |
| ■ <i>Meat Juices</i> | ■ <i>Blood</i> | ■ <i>Dirt</i> | ■ <i>Juice/Wine</i> |
| ■ <i>Egg</i> | ■ <i>Underwear Stain</i> | ■ <i>Ink</i> | ■ <i>Soft Drinks</i> |

Control One Touch Selections (Model 9220)

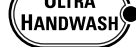
	<i>Cycle</i>	<i>Wash Speed</i>	<i>Description</i>
	WHITES HOT	Fast	For heavy to lightly soiled white cottons, household linens, work and play clothes.
	COLORS WARM	Fast	For heavy to lightly soiled colorfast cottons, household linens, work and play clothes.
	COLORS COLD	Medium	For non-colorfast cottons and blends, and items that are labeled cold wash by the fabric manufacturer.
	EASY CARE	Medium	For knits, wrinkle-free and permanent press items.
	ULTRA HANDWASH	Very Slow	Uses an extra slow speed agitation combined with periods of soak to provide a true handwash for all of your delicate washables.

Cycle Options



SIGNAL

Alerts you when the cycle is complete.

Press **SIGNAL** to select low, medium or high volume, or to turn the beeper off.



2ND RINSE

Adds a second cold rinse to any cycle.



WARM RINSE

Changes the final rinse of a wash cycle from a cold to a warm rinse.



DELAY START

Use to delay the start of your washer.

- 1 Choose your wash cycle and any options.
- 2 Press **DELAY START**. You can change the delay time in 30 minute increments by one of the following methods, depending on the model:
 - Using the arrow pads beneath the **Time Remaining** display
 - Repeatedly pressing the **DELAY START** pad until the desired time is shown
- 3 Press the **START** pad to start the countdown.

The countdown time will be shown in the **Time Remaining** display.

Cycle Status

CYCLE STATUS

- *FILL* ● *RINSE*
- *SOAK* ● *2ND RINSE*
- *WASH* ● *SPIN*

Cycle Status Indicators

On some models, cycle status indicator lights show what part of the cycle the washer is in. On models without indicator lights, the cycle status will show in the display.

Flood Protection

The Profile model is equipped with a flood protection feature. If the low level pressure switch is opened while the washer is in idle mode, the electronic control will activate the drain pump to extract any water in the tub. The rate of water extraction during flood protection exceeds the rate of fill under normal water conditions. The pump will continue to operate for 60 seconds after the low level switch has closed.

Cycle Charts

Cycle Definitions					
Base Cycle	Default Load Size	Default Soil Size	Default Fill Temperature	Default Spin Speed	Optional Spin Speed
Whites	Giant	Medium	Hot	Fast	Any
Colors	Large	Medium	Warm	Medium Fast	Any
Dark Colors	Large	Light	Cold	Medium Fast	Any
Easy Care	Medium	Medium	Warm	Medium	Any
Casuals	Medium	Medium	Warm	Medium	Any
Knits	Medium	Medium	Warm	Medium	Any
Delicates	Medium	Light	Warm	Extra Slow	Extra Slow, Slow
Ultra Hand Wash	Extra Small	Light	Cold	Extra Slow	Extra Slow
Quick Rinse	Medium	None	Cold	Medium Fast	Any
Drain/Spin	None	None	None	Fast	Any
Soak	Medium	None	Warm	Medium	Any
Speed Wash	Extra Small	Light	Warm	Fast	Any
Jeans	Large	Heavy	Warm	Fast	Any
Khakis	Medium	Medium	Warm	Medium Fast	Any
Dress Shirts	Medium	Medium	Warm	Medium	Any
Knit Shirts	Medium	Medium	Warm	Medium Fast	Any
Athletic Wear	Medium	Medium	Warm	Medium Fast	Any
Play Clothes	Large	Heavy	Warm	Medium Fast	Any
Underwear	Medium	Medium	Warm	Medium Fast	Any
Everyday Wear	Large	Medium	Hot	Medium Fast	Any
Towels	Giant	Light	Hot	Fast	Any
Sheets	Giant	Medium	Hot	Medium Fast	Any
Mats/Rugs	Medium	Heavy	Warm	Medium Fast	Any
Table Linen	Medium	Stain	Warm	Medium	Any
Infant Wear	Large	Heavy	Hot	Medium Fast	Any
Silks/Linens	Medium	Light	Cold	Extra Slow	Extra Slow
Lingerie	Small	Light	Warm	Extra Slow	Extra Slow
Stain Catsup	Small	Stain	Warm	Medium	Any
Stain Chocolate	Small	Stain	Warm	Medium	Any
Stain Meat Juice	Small	Stain	Warm	Medium	Any
Stain Egg	Small	Stain	Warm	Medium	Any
Stain Dingy Whites	Small	Stain	Hot	Medium	Any
Stain Perspiration	Small	Stain	Warm	Medium	Any
Stain Blood	Small	Stain	Cold	Medium	Any
Stain Underwear	Small	Stain	Warm	Medium	Any
Stain Grass	Small	Stain	Warm	Medium	Any
Stain Grease	Small	Stain	Warm	Medium	Any
Stain Dirt	Small	Stain	Warm	Medium	Any
Stain Ink	Small	Stain	Warm	Medium	Any
Stain Milk	Small	Stain	Warm	Medium	Any
Stain Coffee/Tea	Small	Stain	Warm	Medium	Any
Stain Juice/Wine	Small	Stain	Warm	Medium	Any
Stain Soft Drink	Small	Stain	Warm	Medium	Any

Wash Speeds*						
Cycle		Ex Small	Small	Medium	Large	Giant
Cotton	Initial Speed (SPM)	100	130	140	155	155
	Step Down Speed (SPM)	100	100	120	120	155
Easy Care	Initial Speed (SPM)	80	100	120	140	140
	Step Down Speed (SPM)	80	80	100	120	140
Delicate	Initial Speed (SPM)	60	80	80	80	80
	Step Down Speed (SPM)	60	60	80	80	80
Ultra HW	Initial Speed (SPM)	30	30	30	30	30
	Step Down Speed (SPM)	30	30	30	30	30
Quick Wash	Initial Speed (SPM)	100	130	140	155	155
	Step Down Speed (SPM)	100	130	140	155	100

*Strokes Per Minute (SPM)

Agitation Times											
			Light Soil		Medium Soil		Heavy Soil		Stain Soil		
Cycle	Sub-Phase	Repetitions	Agitate	Soak	Agitate	Soak	Agitate	Soak	Agitate	Soak	Rinse
Cotton	Initial	1	360**	0**	360**	0**	360**	360**	360**	0**	180**
	Step Down	1	180**	0**	360**	0**	540**	540**	720**	0**	0**
Easy Care	Initial	1	360**	0**	360**	0**	360**	360**	360**	0**	180**
	Step Down	1	60**	0**	240**	0**	420**	420**	600**	0**	0**
Delicate	Initial	1	360**	0**	360**	0**	360**	360**	360**	0**	180**
	Step Down	1	60**	0**	240**	0**	40**	540**	720**	0**	0**
Ultra HW	Initial	2	75**	180**	75**	240**	75**	75**	75**	360**	180**
	Step Down	1	75**	0**	75**	0**	75**	75**	75**	0**	0**
Quick Wash	Initial	1	240**	0**	300**	0**	360**	360**	420**	0**	90**
	Step Down	0	0**	0**	0**	0**	0**	0**	0**	0**	0**

** in seconds

Example							
				Heavy Soil**			
Cycle	Sub-Phase	Large*	Sub-Phase	Reps	Agitate	Soak	Rinse
Ultra HW	Initial	30	Initial	2	75	300	180
	Step Down	30	Step Down	1	75	0	0

Spin Speed RPM		
Spin Cycle	Delicate Spin Speed	Cotton Spin Speed
Extra Slow	150	450
Slow	350	550
Medium	450	630
Medium Fast	550	700
Fast	630	850

Spin Steps		
Step #	RPM	Seconds
1	150	45
2	350	45
3	450	45
4	550	45
5	630	45
6	700	45
7	850	45

Component Locator Views

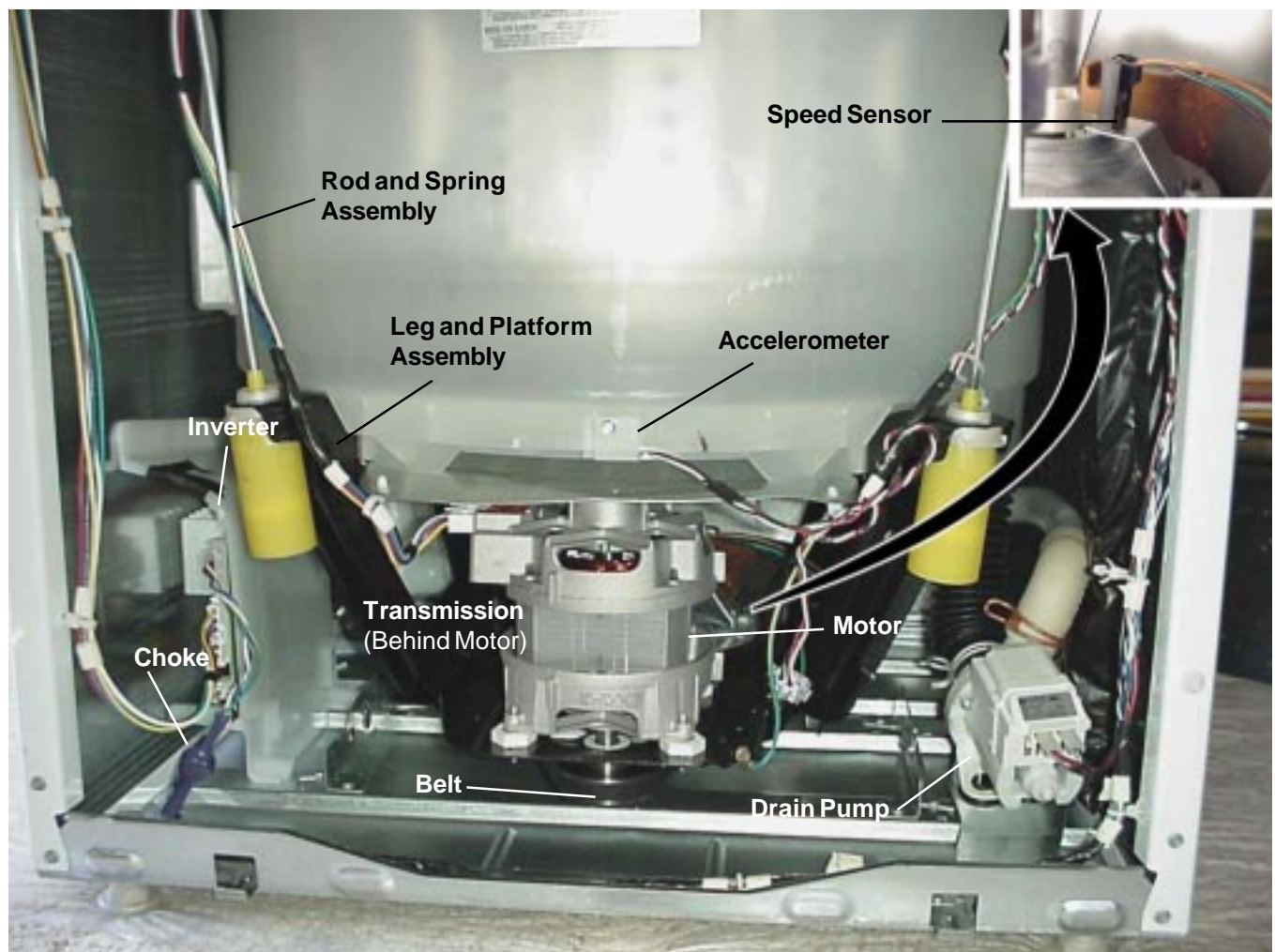
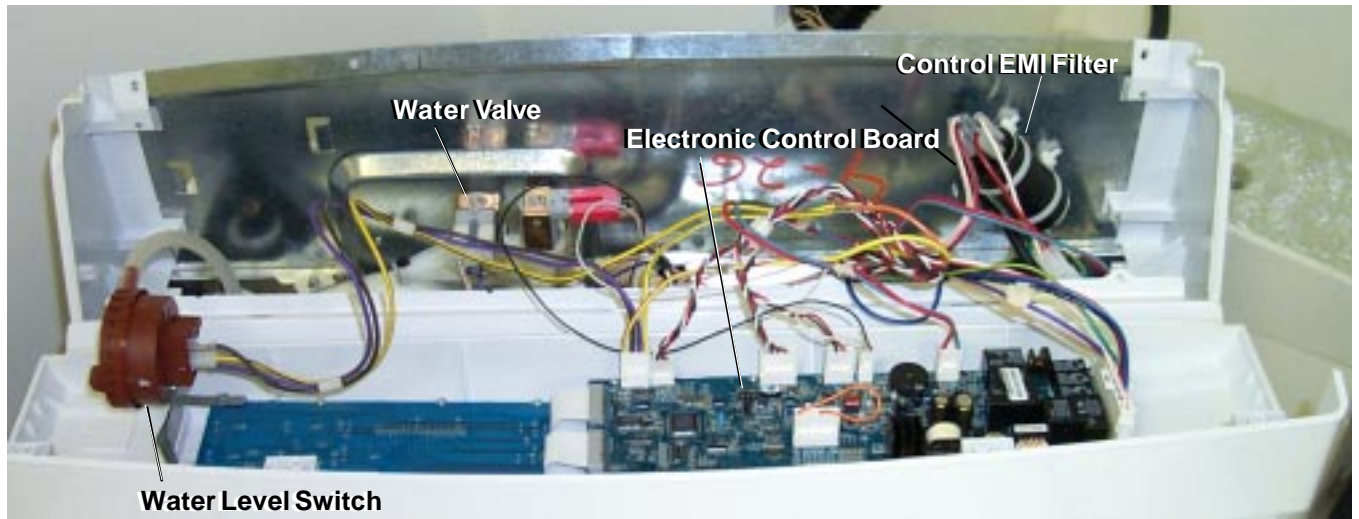

Washer Components

Leveling Legs

The front legs are a screw type and are adjusted by turning the legs clockwise to decrease leg extension and counterclockwise to increase leg extension.

The rear legs should be adjusted after the front of the machine is level from side to side. To adjust the rear legs, tilt the washer forward (pivot on front legs) about 4 to 6 inches. This action will set rear legs to correspond to the front settings. Gently set the washer back down.



P0003576

Control Panel

To place the control panel in the service position:

1. Remove 4 screws from the rear of the control panel.
2. Gently pull on each corner to unsnap the control panel from the sides of the unit.

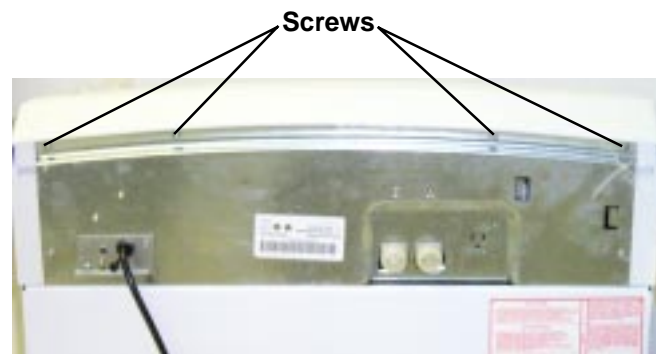

3. Rotate the control panel forward approximately 1 inch and slide to the right to unlock the bottom locking tabs.



4. Lift the panel up and off the cover panel and rotate down.

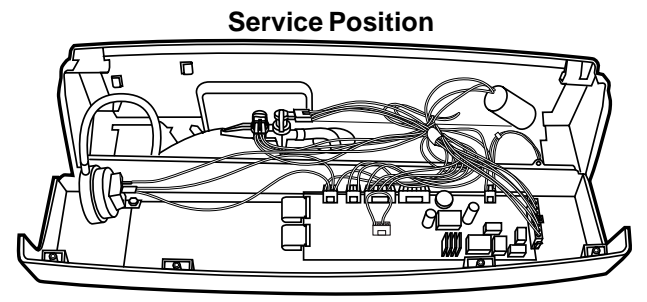

Front Panel

The front panel is a removable, galvanized sheet metal section. The front panel is fastened at the top by 2 metal spring clips, and at the bottom by 2 metal tabs which protrude from the base of the unit into slots in the panel bottom.

Most major mechanical components can be accessed by removing the front panel.

To remove the front panel:

1. Locate 2 spring clips between the top cover and front panel by aligning a putty knife with left or right edge of lid (see illustration).
2. Insert the putty knife and push forward to release clips.
3. Rotate the front panel forward and lift off the bottom tabs.

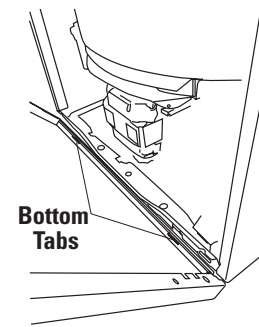

Cover/Lid Assembly

The cover/lid assembly is fastened at the front by 2 screws, on the sides by 2 metal catches, and at the back by 3 locking tabs which protrude from the bottom of the control panel.

Note: Do not allow lid to swing open when cover/lid assembly is removed. Damage may result.

To remove the cover/lid assembly:

1. Remove the front panel and control panel (see Front Panel and Control Panel).
2. Disconnect 2 wire clips and the lid lock harness from the electronic control board.
3. Remove 2 (1/4-in.) hex screws securing the front of the cover/lid assembly to the cabinet.
4. Remove the lid switch from the cover/lid assembly (see Lid Switch).
5. Pull the top cover toward you while lifting up the front edge to release the side catches and rear locking tabs. Remove the top cover.

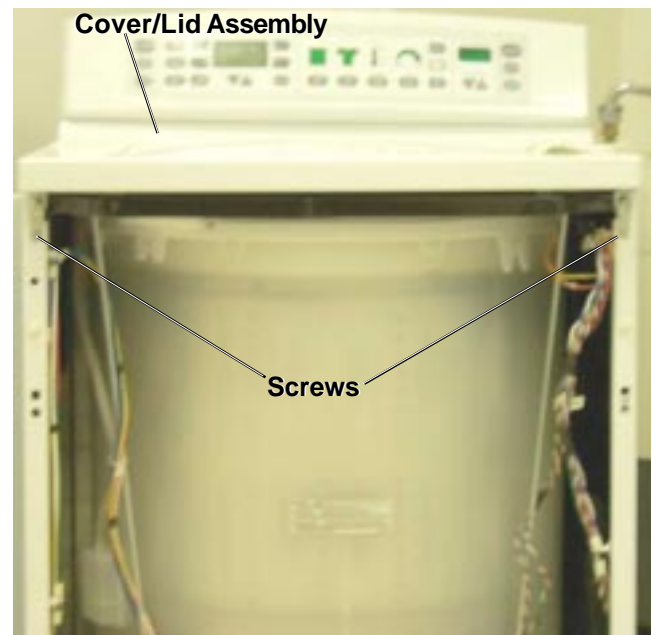

Drain Pump

Warning:

- The pump may not be grounded. Unplug the unit before servicing to avoid electric shock.
- The pump may begin operation without any advanced notice.
- This model is equipped with flood protection. If the low pressure switch opens while the washer is in idle mode, the electronic control board will activate the drain pump. Pump operation will continue for 60 seconds after the low level switch closes.

The drain pump is coupled to a 120 VAC, 60 Hz, 85 watt motor. The pump will operate independently of other mechanical components, and will evacuate water at various times during all cycles.

The pump receives L1 voltage directly from the electronic control board and switching takes place on the L1 side. When the electronic control board has closed the L1 side of the pump circuit (commanding the pump to run), the board measures the current of the pump and uses the measurements to determine if the pump is pumping water or air. The pump wiring includes a snubber to reduce EMI. A shorted snubber may cause a failure to occur on the electronic control board (see Electronic Control Board).

To test the pump:

Place the unit in the service mode (see page 34) and advance to the Pump Test function. The pump should activate upon entering function. P should be displayed on the Digital Seven Segment Display (DSSD) along with the pump current draw in tenths of an amp.

To remove the pump:

Note: Water will remain in hoses even when the tub appears empty. Use care to avoid water spills.

1. Disconnect power to the machine.
2. Lower the drain hose into a small bucket to remove any water remaining in hose.
3. Remove the front panel (see Front Panel).
4. Disconnect the lead wires.
5. Pinch off the black sump hose to prevent water spills.
6. Remove hose clamps and hoses from the pump.
7. Remove 2 (3/8-in.) screws and the pump.

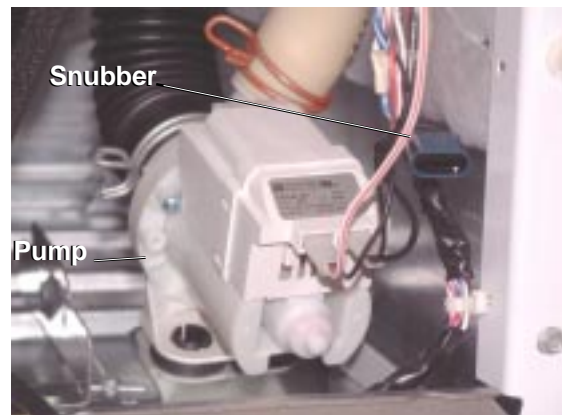

Drive Belt

The drive belt (P/N WH1X2026) is located under the leg and platform assembly. It extends from the motor pulley to the transmission pulley. To adjust the belt, loosen the 4 motor mounting nuts and slide the motor forward until the belt is tight, then retighten the nuts.

Note: Proper belt tension is 1/2-in. deflection at midpoint between pulleys.



P0003587

Agitator

The agitator is a dual-action, 2-piece, ratcheting type which sets on an air bell coupling. Remove the agitator by grasping the bottom and sharply pulling up (use agitator strap WX5X1326).

To align the agitator for reassembly, match the grooves in the air bell to the grooves inside the agitator. The fins on the outside of the agitator are aligned with the grooves on the inside of the agitator.

To remove the air bell coupling, remove the 7/16-in. bolt and lift off the transmission shaft.



Spin Basket

The spin basket has been newly designed for this Profile model. The new basket is constructed of stainless steel and is the largest in the industry at 3.5 cu ft. The basket has two rows (upper and lower) of protruding ribs formed around its circumference. These ribs increase water extraction from clothing during the spin cycle.

Due to the higher rpm of this model, the 1-11/16 in. hub nut securing the tub is made of Stainless Steel and must be torqued to 150 ft. lbs. If the hub nut is removed, it must be tightened to 150 ft. lbs. If the hub nut wrench (PN WX5X1325) is used to tighten the hub nut, the wrench must be struck with a rubber mallet or dead blow hammer until it will not tighten any further. This may take 30 to 50 hits with a rubber mallet or dead blow hammer.

To be certain that the nut will not tighten any further, align the spanner wrench with the holes in the basket and use them as a guide to determine that the nut will not move when the hub nut wrench is struck. Impact wrenches are set to more than 150 ft lbs and should tighten the nut sufficiently.

Note:

- The basket and hub come as an assembly. Do not change the basket without changing the hub.
- Step 7 of the basket removal procedure instructs to remove the tub with motor and transmission. It may be helpful to read Tub With Motor and Transmission removal before beginning.

To remove the basket:

1. Remove the front panel and the cover/lid assembly (see Front panel and Cover/lid assembly).
2. Disconnect 4 dampening straps from the tub by removing 4 (5/16-in.) hex screws.



3. Remove the tub cover by lifting the 8 tabs.
4. Remove the agitator. Use agitator strap (PN WX5X1326).
5. Remove the 7/16-in. hex head bolt and air bell coupling from the transmission spline shaft.

Note:

- The 1-11/16 in. hub nut is Stainless Steel and has been torqued to 150 ft. lbs.
- The word “LOOSEN” and an arrow appear on the hub nut. Turn **clockwise** to remove.

Caution: Use only a rubber mallet, dead blow hammer, or impact wrench to remove the hub nut. Use of a steel head hammer may result in damage to the spin basket.

6. Remove the left-handed, stainless steel hub nut using a spanner wrench and a rubber mallet or dead blow hammer, or an impact wrench.

Note: Hub nut must be tightened to 150 ft. lbs. when reinstalling, see Spin Basket.

7. Remove the tub with motor and transmission (see Tub With Motor and Transmission).
8. Place the tub with motor and transmission on its side, and slide tub out of the unit.

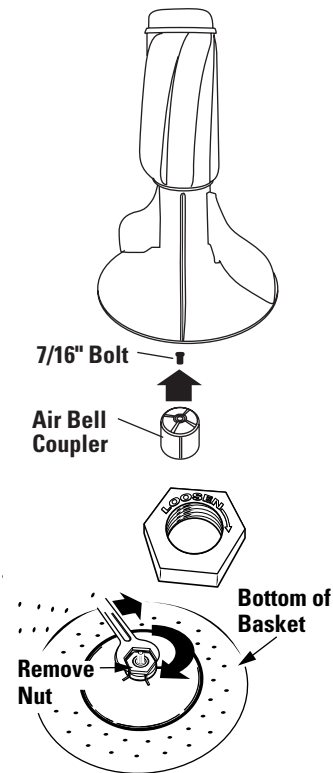

Suspension

The tub and motor assembly (spin basket, tub, motor, transmission, and leg and platform assembly) is suspended by four rod and spring assemblies. The rod and spring assemblies are attached to each corner of the cabinet. They extend down and connect to the leg and platform assembly. This arrangement provides limited movement to the tub and motor assembly, independent of the cabinet when agitating and spinning, thus reducing cabinet travel and vibration. Front and rear suspension rod compressions vary to compensate for the added weight of the motor. The rods are color-coded to ensure that they are replaced in the correct position (**front - yellow, rear - white**).

The tub has 4 dampening straps attached to the four corners of the cabinet. These straps prevent excessive rotation and movement during agitation, startup, and braking.

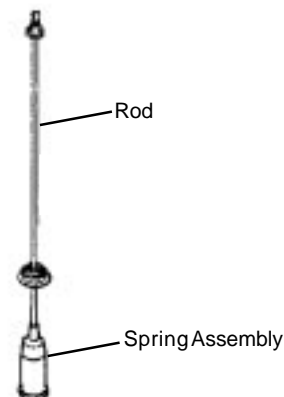

Transmission

Note:

- The tub must be removed when replacing the transmission.
- Replace the tub seal (PN WH02X10032) when replacing the transmission.
- The speed sensor and magnet collar must be transferred to the replacement transmission.

To remove the transmission:

1. Remove the tub with motor and transmission, and the spin basket (see Tub With Motor and Transmission and Spin Basket).
2. Remove the transmission drive pulley by holding the belt and removing the 3/4-in. pulley nut.

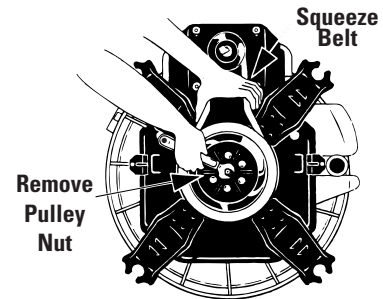

3. Remove 4 (3/8-in.) bolts mounting the transmission to the leg and platform assembly.

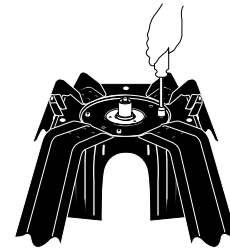

4. Remove 4 (1/2-in.) hex bolts securing the leg and platform assembly to the tub and remove the leg and platform assembly.

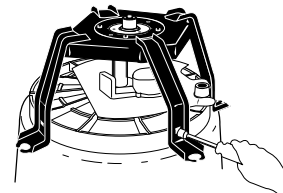

5. Lift the transmission up and out of the tub.
6. Remove the speed sensor and magnets, and transfer to the replacement transmission.

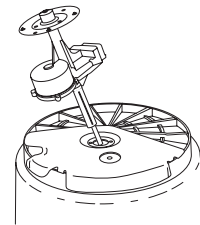

Note: The transmission and brake are one assembly and are replaced as a single component.

7. Remove the tub seal and install a new one.

Tub With Motor and Transmission

Note: The motor can be replaced without removing the tub. Refer to the Motor section. The tub must be removed when replacing the transmission.

To remove the tub with motor and transmission:

1. Remove the spin basket (see Spin Basket).
2. Remove the hub ring from the transmission.
3. Disconnect the motor harness connector, the frame grounding wire, and the water pressure switch hose.
4. Pinch off the drain sump hose to prevent water spills.
5. Disconnect the drain sump hose (black hose) at the pump.

Note: The front and rear rod and spring assemblies have different spring compressions and should not be interchanged (front - yellow, rear - white).

6. Disengage the front rod and spring assemblies by raising the tub and removing the spring assemblies from the leg and platform assembly.
7. Disengage the rear rod and spring assemblies by raising the rear of the tub and removing the spring assemblies from the leg and platform assembly.
8. Push the top of the tub assembly toward the rear of the cabinet, then pull the bottom of the tub assembly out of cabinet.

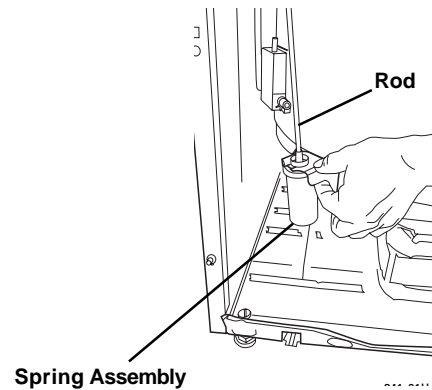
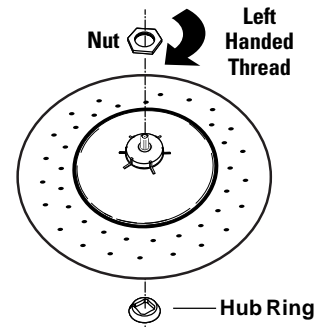

Lid Switch

Note: Also refer to Lid Switch Diagnostic.

The lid switch is fastened to the cover/lid assembly by a single latch. It is a safety feature that prevents the machine from agitating or spinning when the lid is open. The switch is closed by a magnet that is attached to the lid. When the lid is shut, the magnet will cause the switch to close the circuit to the electronic control board, allowing normal functions to occur. When the lid is opened, the switch will open the circuit, which will prevent agitating or spinning.

If the lid switch fails to open, (due to a failed lid switch, missing magnet on the lid, or not raising the lid) for 3 consecutive cycles, the unit will enter the lid switch redundancy mode when a 4th cycle is attempted: The unit will beep twice, log the lid switch error code, and disable the machine. When the lid switch opens, the redundancy mode will be reset, restoring machine function; however, the lid switch error, will remain logged until it is cleared from the error codes function of service mode.

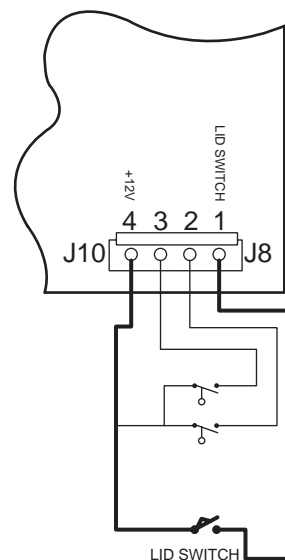

To remove the lid switch:

1. Remove the front panel (see Front Panel).
2. Reach under the lid assembly and locate the lid switch. Squeeze the lid switch latch in to release it while gently pushing the switch upward, then guide the lid switch through the opening.

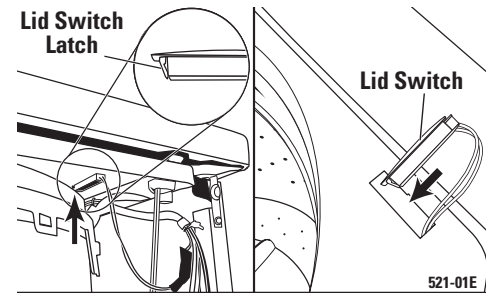

Lid Switch Diagnostics

To determine if the lid switch circuit is operating normally, enter Service Mode (see Service Mode). Press the CUSTOM 2 pad to advance to the Lid Switch Test mode. While in this mode, if the lid switch is operating correctly, the Digital Seven Segment Display (DSSD) should display OPn when the lid is open and CLS when the lid is closed.

Note: If service mode indicates a defective lid switch, confirm this diagnosis by verifying that the magnet is attached to the lid, checking the lid switch connections, and by manually checking the continuity of the switch before replacing.

Lid Lock

The lid lock is mounted by 2 Phillips screws under the top panel at the front of the lid opening. It is a safety feature which prevents the lid from being opened when the basket is spinning. The lid lock is controlled by the electronic control board, which monitors the speed sensor for transmission rotation. When 50 rpm is sensed, the electronic control board will energize the lid lock with 12 VDC, locking the lid. The lid lock will remain energized until the electronic control board determines that the basket has stopped spinning.

Should the lid lock fail, and the lid switch be opened during spin for more than 5 seconds, the electronic control will limit high speed spin to 630 rpm and log the lid lock error code. Spin speed will be limited to 630 rpm until the lid lock error is reset in the service mode.

Warning: The lid lock will not be activated by the electronic control board if the speed sensor is faulty, disconnected, or has an open in the circuit.

To test the lid lock:

1. Unplug the unit for 15 seconds, then plug the unit back in. If the lock is functioning correctly, the lid lock will briefly activate when power is applied.
2. Place the unit in spin using service mode or the Drain & Spin cycle. The lock should activate when 50 rpm is attained.

If the lid lock does not activate when power is removed and restored, suspect a faulty lid lock or electronic control board. If the lid lock activates when power is applied, but does not activate when the unit is spinning, suspect a faulty speed sensor or speed sensor wiring.

To remove the lid lock:

1. Place the control panel in the service position (see Control Panel).
2. Disconnect the lid lock harness connector.
3. Remove the front panel (see Front Panel).
4. Remove 2 screws securing the lid lock to the top panel.
5. Remove 2 screws securing the top panel to the cabinet and lift the front of the top panel.
6. Remove the lid lock.

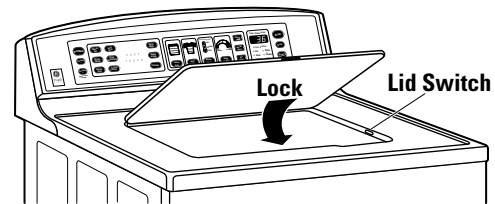
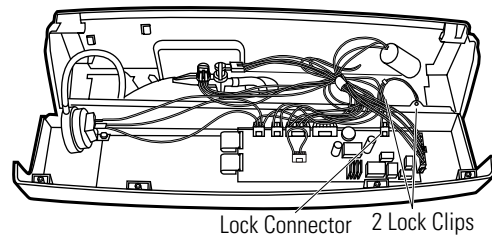

Water Valve

The water valve is a 120 VAC, double solenoid type, which is accessed by placing the control panel in the service position.

The water valve wiring is equipped with snubbers, on each water valve connector, to reduce EMI. A shorted snubber may cause a failure to occur on the electronic control board (see Electronic Control Board).



Automatic Temperature Control (ATC)

The automatic temperature control feature is used to provide optimum wash water temperature. The ATC uses a water temperature sensor (thermistor) with a negative temperature coefficient (as temperature rises, resistance lowers), located in the top of the hose and water inlet to detect incoming water temperature. The electronic control board uses the difference between the voltage sent to the water temperature sensor and voltage returning from the water temperature sensor to determine the temperature of the incoming water, and to make (ATC) decisions.

The ATC should maintain the water temperature in the tub within the ranges specified in the Water Temperatures chart by opening or closing the hot and cold water valves.

To prevent sudden water temperature changes on consumer's hands, the ATC does **not** function when the lid is open during warm or cold fill.

Note:

- The ATC will flush the water inlets with hot water for the first 6 seconds of a warm wash cycle.
- During cold water fill, the hot water valve will open if the water inlet temperature is too cold.

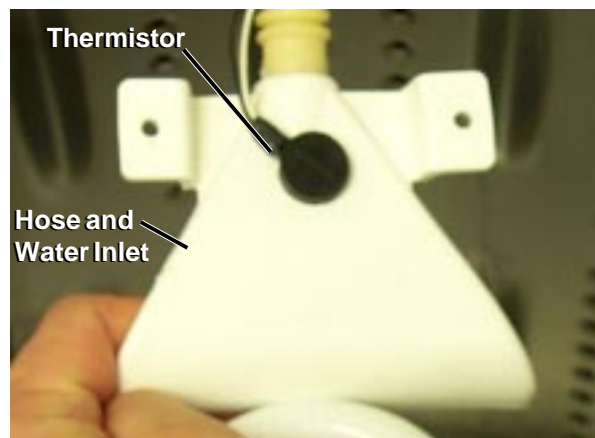

ATC Temperature Chart		
Temperature Setting	Wash Temperatures	Rinse Temperatures
Hot	115 +/- 8 °F	N/A
Warm	80 +/- 7 °F	70 +/- 7 °F
Cold	60 +/- 7 °F	Tap Water

Water Level Switch

Note: Also refer to Water Level (Load Size) Diagnostic.

The water level switch has two switches in one housing and is located inside the control panel. The water level switch is connected by a hose to an air reservoir near the bottom of the outer tub. When the water level rises in the washer tub, air is trapped in the reservoir. As the water level rises, the air pressure in the reservoir increases. When 6 inches of water have accumulated in the washer tub, the appropriate pressure will be achieved and the low switch will open. The high switch will open when the water in the tub has reached its maximum level. Mid-level fills are timed, based on the amount of time it took to fill to lowest level.

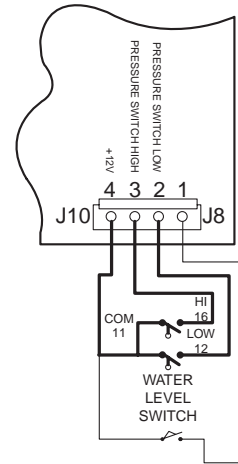

This Profile model is equipped with a flood protection feature. If the low level pressure switch is opened while the washer is in idle mode, the electronic control will activate the drain pump to extract any water in the tub. The rate of water extraction during flood protection exceeds the rate of fill under normal conditions. The pump will continue to operate for 60 seconds after the low level switch has closed.

Water Level (Load Size) Diagnostics

To determine if the water level switch and electronic control board are functioning correctly, perform the following:

1. Place the unit in service mode.
2. Index to the Low Level Pressure Switch test and press start. The washer will fill with water until the low level pressure switch opens at the extra low level, approximately 6.1 inches.
3. Index to the High Level Pressure Switch test and press start. The washer will fill with water until the high level pressure switch opens at the giant level, approximately 14 inches.

Note: It will be necessary to shut the lid in order to reset the electronic control board and advance to the next water level.

Each load size should be at the following level:

- Giant - 14.0 (+/- 0.5) inches, 26.3 gallons
- Large - 12.5 (+/- 0.5) inches, 23.1 gallons
- Medium - 10.4 (+/- 0.5) inches, 19.9 gallons
- Small - 8.2 (+/- 0.5) inches, 16.8 gallons
- Extra Small - 6.1 (+/- 0.5) inches, 13.6 gallons

If the water level of an **Extra Small Load** is deeper than 6.1 (+/- 0.5) inches, check to see that the water level switch is closed when the water level is below 6.1 (+/- 0.5) inches and that it is open when the water level is 6.1 (+/- 0.5) inches and above. If the water level sensor functions properly, replace the electronic control board.

Note: Small, Medium, and Large Load Size water levels are timed in the electronic control board. The timing is based on the amount of time it takes to fill to the lowest level.

If the water level of a **Small, Medium, or Large Load** is deeper than 8.2 (+/- 0.5) inches (Small), 10.4 (+/- 0.5) inches (Medium), or 12.5 inches (Large), check to see that the Extra Small Load water level is operating normally (see above paragraph). If the Extra Small Load operates normally, replace the electronic control board.

If the water level of a **Giant Load** is deeper than 14.0 (+/- 0.5) inches, check to see that the water level switch is closed when the water level is below 14.0 (+/- 0.5) inches, and that it is open when the water level is 14.0 inches and above. If the water level sensor is functioning properly, replace the electronic control

Note: Before disconnecting hose from water level switch, be sure water level in machine is below bottom of wash basket. After reconnecting hose, put machine in spin for at least 1 minute before checking operation of switch.

To remove water level switch:

1. Place the control panel in the service position (see procedure).
2. Remove the screw securing the switch.
3. Disconnect wiring and hose from switch, and remove.

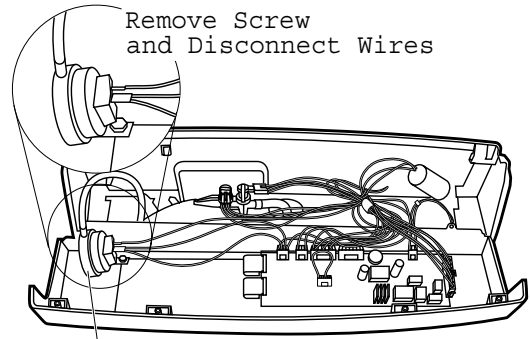

Water Level Switch

Electronic Control Board

The electronic control board consist of 2 circuit boards connected by 2 ribbons. The boards are attached to the back of the control panel and control all washer functions. The boards are replaced with the control panel as an assembly.

A voltage reading between 4.5 and 5.5 VDC should be measured at connector J2 between pin 3 (V sense) and pin 2 (sensor ground). A voltage reading greater than 5.5 VDC indicates a faulty electronic control board. A voltage reading lower than 4.5 indicates one of the following: Faulty electronic control board, faulty wire harness between J2 and CN9, or faulty inverter.

If a faulty board is suspect, check for continuity across the fuse and visually inspect the surge protector mounted on the board. If no continuity is read across the fuse, or if the surge protector appears burnt or damaged, replace the board.

If a faulty electronic control board is diagnosed, check the water valve snubber (see Water Valve), pump snubber (see Pump), and inverter snubber (see Inverter) for a shorted condition. If a shorted snubber is detected, replace the snubber before installing the new control.

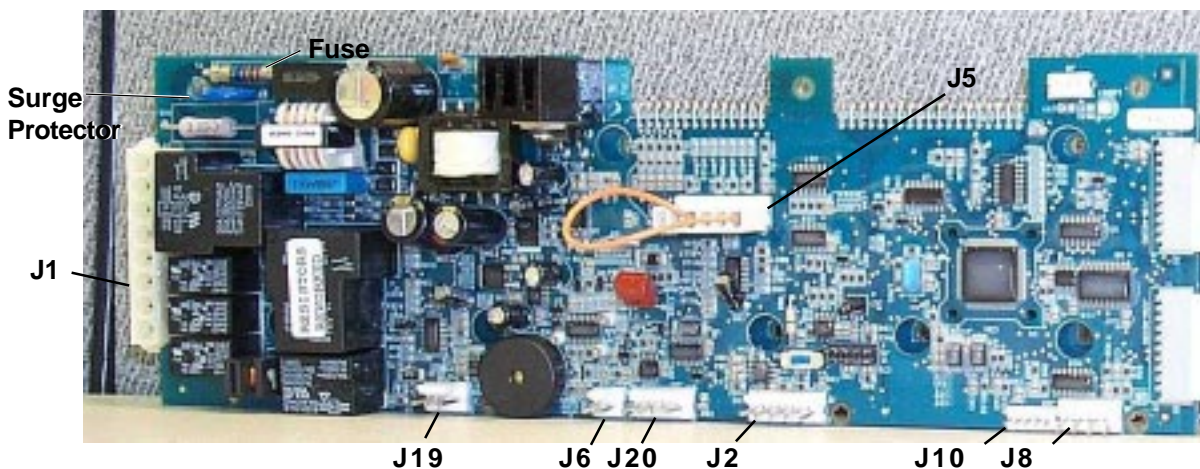
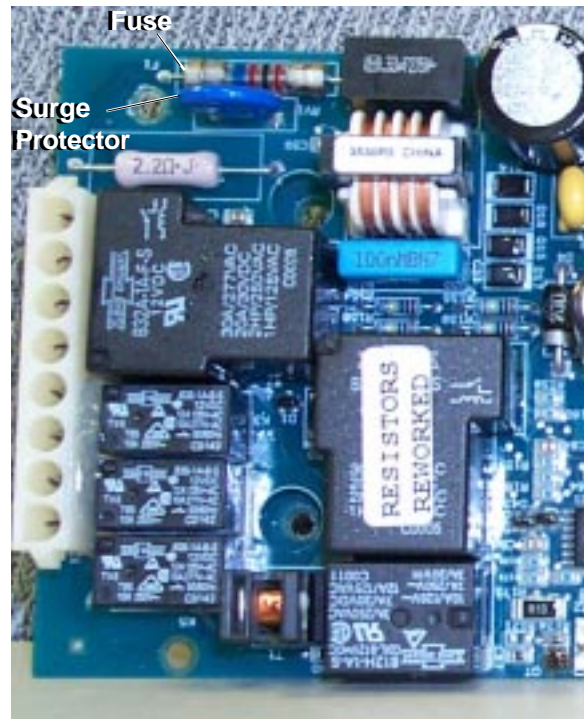

To remove the electronic control board:

Caution:

- When replacing the control panel, remove the protective coating from the overlay prior to power-up to prevent electrostatic discharge (ESD) from damaging the new board.
 - To prevent electrostatic discharge, ground yourself to the washer cabinet or use an ESD wristband.
1. Disconnect power to the machine.
 2. Place the control panel in service position (see control panel).
 3. Disconnect the harness connections, and remove and retain the model selector harness plug for reassembly.
 4. Remove the control panel assembly.

Control EMI Filter

The potential exists for the washer to cause electronic devices and systems in the vicinity to experience disruption. To eliminate the likelihood of disruption, the unit is equipped with a conductive noise filter. Should interference with electronic items be reported, suspect a problem with the filter. The ground wire attached to the bottom of the filter must have a good connection for the filter to operate properly. Check to make certain that the ground wire is connected properly before replacing the filter.

The filter is accessed by placing the control panel in the service position.



Choke

The choke is an EMI (electromagnet interference) filter located in the lower portion of the wiring harness, close to the inverter. It is designed to reduce EMI produced by the unit. EMI has the potential to disrupt the operation of electronic devices and systems in its vicinity. Should the customer complain of interference with other electronic items while the unit is operating, check to make sure the filter (see Filter section) is properly grounded. The choke is not a replaceable part. In the event the choke fails (open), it is to be bypassed.

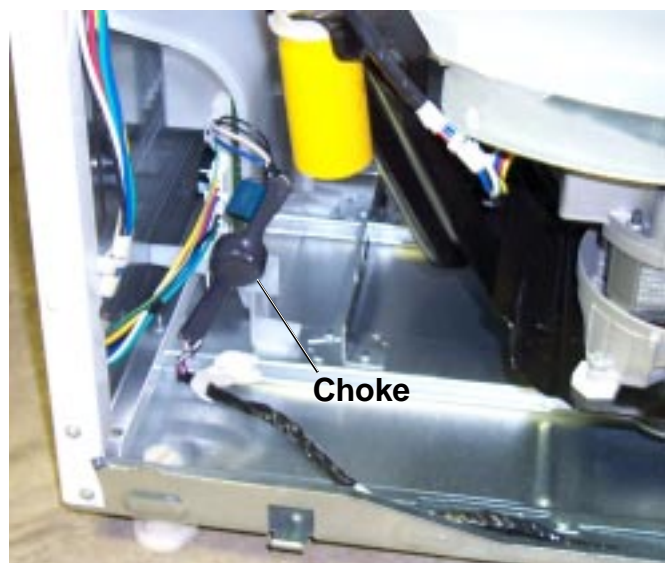

Motor

WARNING:

- The motor is not grounded. Unplug the unit before servicing to avoid electric shock.
- Motor temperature may reach 176 °F. Use care to avoid severe burns.

Note:

- The motor is mounted on 4 ceramic insulators that insulate the motor from cabinet ground.
- The pulley has a ceramic insert to insulate the motor from cabinet ground, should the belt get wet.

The drive motor is a reversing, permanent magnet, 3-phase 230 VAC motor that varies speed and torque when the pulse width modulated voltage from the inverter changes frequency or amount. The motor reverses rotational direction when the inverter reverses electrical polarity to the motor.

The motor has an internal tachogenerator which produces voltage when the motor shaft is rotated. This voltage is monitored by the inverter to determine motor speed. The inverter makes speed adjustments as necessary, based on this information.

The inverter adjusts motor torque as necessary to start the motor; therefore, a clutch is not required. A 45-second ramp-up time can be expected at the start of agitate or spin.

Note: Terminals 1, 2, and 3 (at connector CN10) are the motor windings. Proper resistance for a cold motor is 6 Ω +/- 10% between any 2 of the 3 terminals.

To remove the motor:

1. Remove the front panel (see Front Panel).
2. Remove 4 (3/8-in.) nuts from the bottom of the motor.
3. Move the motor toward the transmission and remove the belt.
4. Rotate the transmission to give the motor clearance. Tilt the top of the motor toward the transmission. Remove the motor.

Note: Proper belt tension is 1/2-in. deflection at midpoint between pulleys.

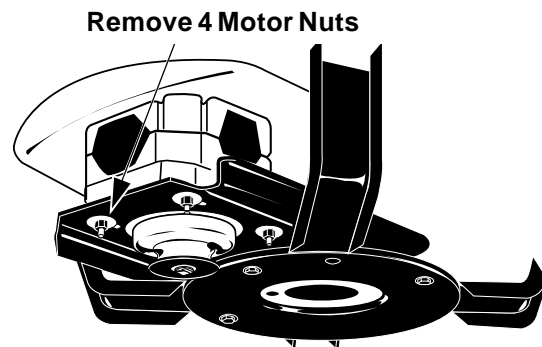

GEA01205

Inverter

The inverter converts line-in, single-phase, 60 Hz, 120 VAC into 3-phase, varying frequency, 230 VAC. The inverter controls motor speed, torque, and direction. It also provides motor over-current and thermal overload protection.

Motor speed is regulated by Pulse Width Modulation (PWM). PWM outputs voltage to the motor in pulses rather than an uninterrupted flow. This pulsing produces effective voltage being received at the motor, which is equivalent to a reduction in voltage.

Motor torque is adjusted throughout the speed range by varying the pulse width modulated voltage to the motor. The inverter monitors the motor current and uses this information to calculate and make motor torque adjustments. This eliminates the requirement of a clutch.

Direction of rotation is changed by the inverter reversing polarity.

The inverter housing is mounted to the side of the cabinet with double-sided tape and to the base of the unit by 2 tabs which fit into slots. Access is obtained by removing the front panel.

The inverter wiring harness includes a snubber to reduce EMI. A shorted snubber may cause a failure to occur on the electronic control board (see Electronic Control Board).

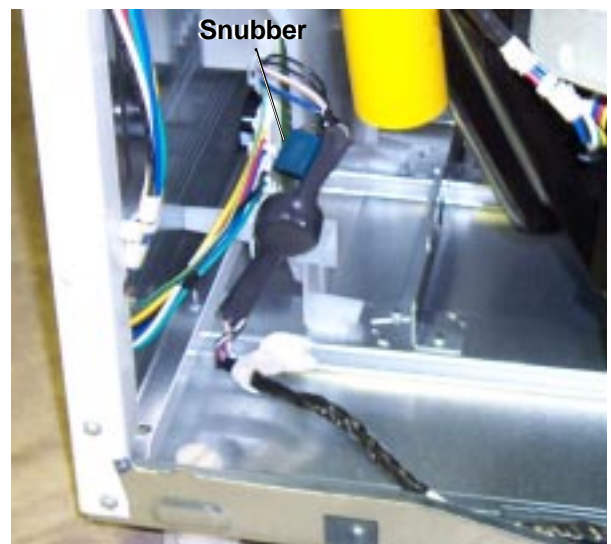
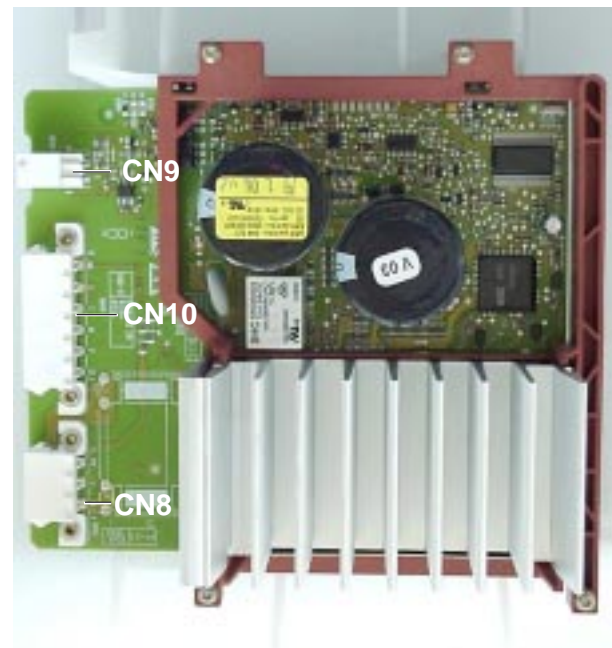

Speed Sensor

The speed sensor is comprised of a sensor mounted on the brake assembly and a set of magnets mounted on the transmission. The sensor remains stationary, but the magnets rotate with the basket. As the transmission rotates, the magnets pass the sensor and a signal is sent to the electronic control board. The electronic control board activates the lid lock and calculates brake stop time based on this signal.

When speed sensor input indicates that the basket is spinning at 50 rpm, the control will engage the lid lock. If the speed sensor fails or an open occurs in the wiring, the lid lock will **not** engage; however, normal function will continue, provided the lid is not raised during spin. If the lid is raised during a spin cycle for more than 5 seconds, the electronic control board will limit the high speed spin to a maximum of 630 rpm and a lid lock error code will be logged. Spin speed will continue to be limited to 630 rpm until the lid lock error is cleared using service mode.

Speed sensor input is also used by the electronic control board to calculate brake stop time. If, within a 1-year period (400 washes), the control board detects 3 stop times in excess of 25 seconds, the control will determine that a catastrophic brake failure has occurred. The unit will immediately be disabled and will display error code E43 on the Digital Seven Segment Display (DSSD). The unit will power up, but no cycle selection will be available. The unit will remain disabled until the error code is reset using service mode.

board.

To test the speed sensor:

1. Place the unit in service mode and index to the Spin Fast Test.
2. Press the START pad and monitor the DSSD.

An rpm displayed on the DSSD indicates an operating speed sensor. No rpm displayed on the DSSD indicates a faulty speed sensor or faulty wiring.

When replacing the transmission, the speed sensor and magnets must be transferred to the replacement transmission.

To remove the speed sensor:

1. Disconnect power to the unit and rotate the transmission by turning the belt to allow access to the speed sensor.
2. Remove the 7/16-in. speed nut fastening the sensor to the brake assembly.
3. Remove 1 T-10 torx screw fastening the magnets to the transmission and remove the magnets.

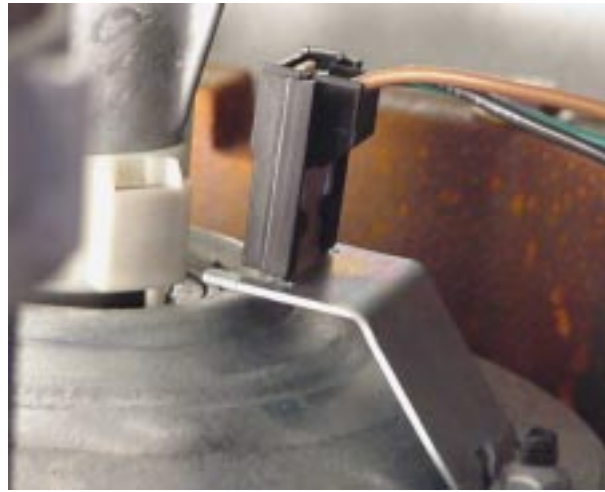

Accelerometer

The accelerometer is located at the front, bottom center of the outer tub. The accelerometer monitors the unit for radial and vertical acceleration and transmits this information to the electronic control board. The electronic control board uses this information to monitor and control the spin basket for an out-of-balance condition during spin. If an out-of-balance condition is detected, the electronic control board will reduce the spin rpm. If, after lowering the speed, an out-of-balance condition is still detected, the control will again lower the spin rpm. The control will lower the spin rpm at the following intervals: 850, 700, 630, 550, 450, 350, 150. Should an excessive out-of-balance condition occur, such as one caused by a broken suspension rod, the unit will step down to 130 rpm, then terminate spin; however, the cycle will continue without spin until completed.

Should the accelerometer fail, the electronic control board will limit spin speed to a maximum of 630 rpm and a spin speed error code will be logged.

To test the accelerometer:

1. Place the unit in service mode.
2. Index to the accelerometer test.
3. Shake the spin basket back and forth by hand while monitoring the DSSD. If the display

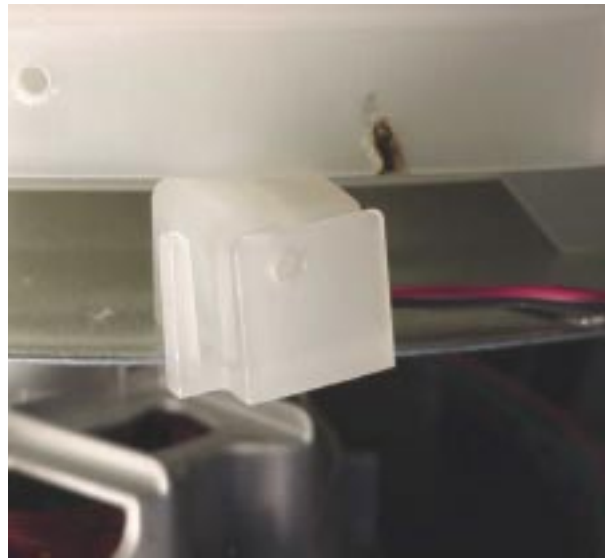

changes, this indicates a good accelerometer. No display change indicates a faulty accelerometer.

To replace the accelerometer:

CAUTION:

- The accelerometer is prone to damage if exposed to electrostatic discharge. Do not splice the wiring of a new accelerometer to the wiring of the old accelerometer.
 - The installer must be properly grounded when handling the accelerometer assembly. An ESD wristband is highly recommended when servicing the accelerometer.
1. Disconnect power.
 2. Remove the top panel and the front panel (see Top Panel and Front Panel).
 3. Disconnect the accelerometer connector from J10, cutting off as close to the main wiring harness as possible, and dispose.
 4. Put on EMI wristband and clip onto any bare metal part of the unit, or touch any bare metal part of the unit with your hand to discharge any static electricity.
 5. Remove the screw securing the accelerometer to the front bottom of the tub. Push it down and off the tub.
 6. Cut the wiring of the old accelerometer at the first taped junction, as close to the main harness as possible, leaving the old harness intact.
 7. Secure the new accelerometer onto the tub, in the same position as the original, being certain the

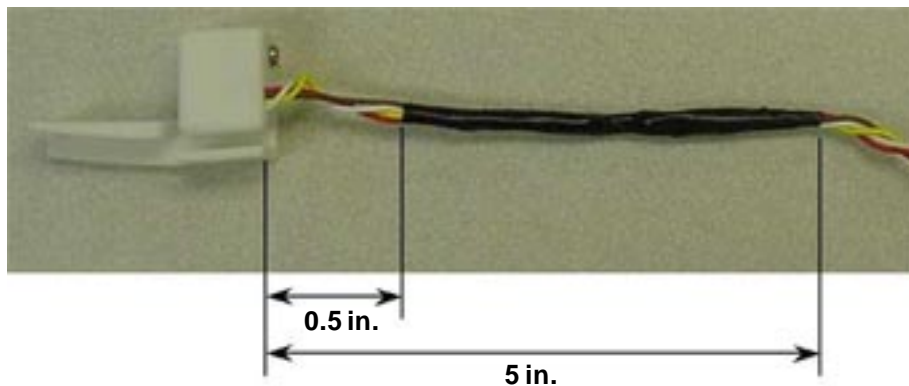

hole in the accelerometer is aligned with hole in the tub.



8. Starting 0.5 in. from the new accelerometer, use electrical tape and tape the wiring a distance of 5 in.

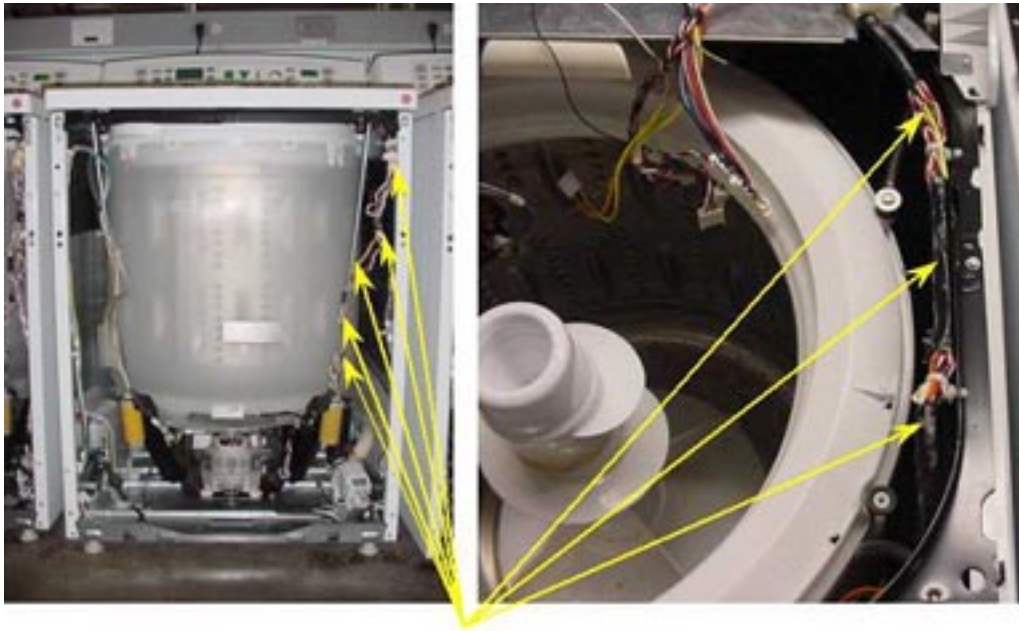

Place tape at 6 in. increments.

9. Starting at the end of the section taped in step 8, tape the new accelerometer wiring harness on the washer wiring harness. Tape the 2 harnesses together for a distance of 4 inches.
10. Wind the new accelerometer wiring around the entire length of the washer wire harness, all the way to the control panel. Tape the accelerometer wires to the washer harness by applying tape every 6 inches.

11. Plug in the new accelerometer connector.
12. Reconnect power and check operation using service mode.

Motor Tachogenerator Test

Perform the following to test the tachogenerator:

1. Unplug the washer and remove the front panel.
2. Disconnect harness connector CN10 from the inverter.
3. Remove the drive belt.
4. Spin the motor by hand, and check for approximately 1 VAC between terminals 4 and 5 of the harness connector.

Note: Voltage is proportional to the motor rpm. As you spin the motor by hand, approximately

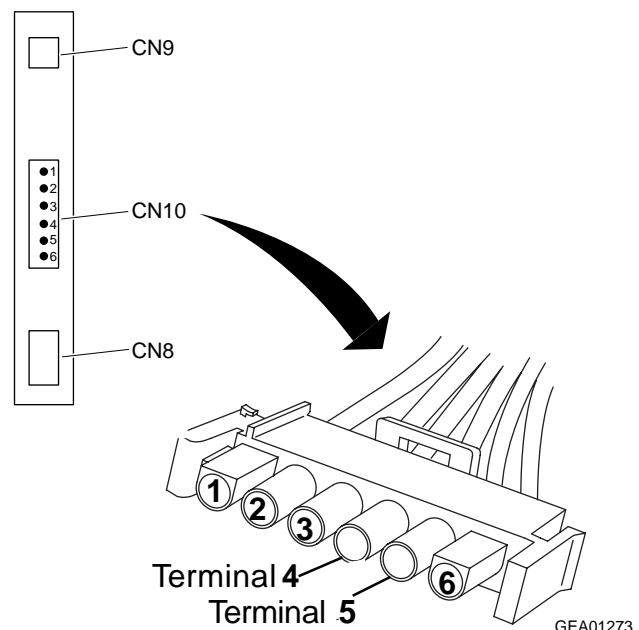

Note: Proper tachogenerator resistance should be 190 Ω +/- 10% between terminals 4 and 5.

Service Mode

Service Mode

Service Mode enables individual machine functions to be selected and performed apart from the unit's normal operation. Service Mode also allows error codes to be displayed.

To enter Service Mode:

1. Turn the unit off at the POWER pad.
2. Remove power to the unit by unplugging it for 15 seconds.
3. Restore power. Within 30 seconds of power-up, simultaneously press and hold the POWER and the START pads for 3 seconds.

When Service Mode is entered, the control panel will display model code.

Enter Service Mode

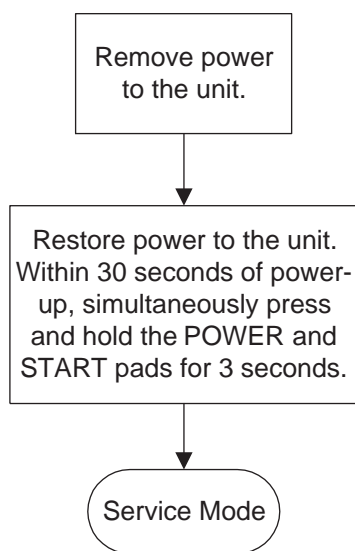

Exit Service Mode

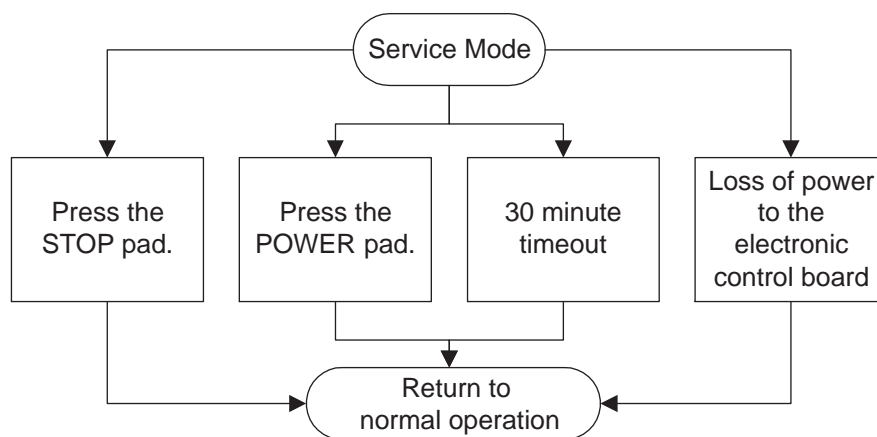

Service Mode can be **exited** in 4 ways:

1. Press the STOP pad.
2. Press the POWER pad.
3. Unplug the unit.
4. 30-minute timeout.

To **index to the next function** within Service Mode, press the CUSTOM 2 pad. To **index back to the previous function**, press the CUSTOM 1 pad.

The table below describes the Service Mode functions. A Service Mode in flowchart and a detailed definition of each function can be found on the following pages.

Service Mode		
Mode	Default Display	Press START
Model Display	Sr or Jr	model selector plug #
Software Version	3 digit software version #	E & 2 digit EEPROM #
EEProm Test	EEP	reprograms EEPPROM from flash
Error Codes	see Washer Error Codes table*	clears fault log
User Interface	All LED's & LCD illuminated	toggles checkerboard on LCD
Water Temp Test	water temperature	no change
Lid Switch Test	OPn or CLS	no change
Hot Water Test	Hot (opens hot valve)	no change
Cold Water Test	cld (opens cold valve)	no change
Low Pressure Switch Test	LOP or LCL	fills with warm until open
High Pressure Switch Test	HOP or HCL	fills with warm until open
Slow Agitate Test	AS (agitates at 30 rpm)	no change
Fast Agitate Test	AF (agitates at 155 rpm)	no change
Pump Test	P & tenths of Amp	no change
Slow Spin Test	SS (150 rpm)	display spin rpm
Fast Spin Test	SF (850 rpm)	display spin rpm
Inverter Test	SEr	cycles connector J2 communication lines from pins 4 to 5
Accelerometer Test	Radial tenths of G's	toggle from radial to vertical accel.

Note: Press CUSTOM 2 to index to next function. Press CUSTOM 1 to index to previous function.

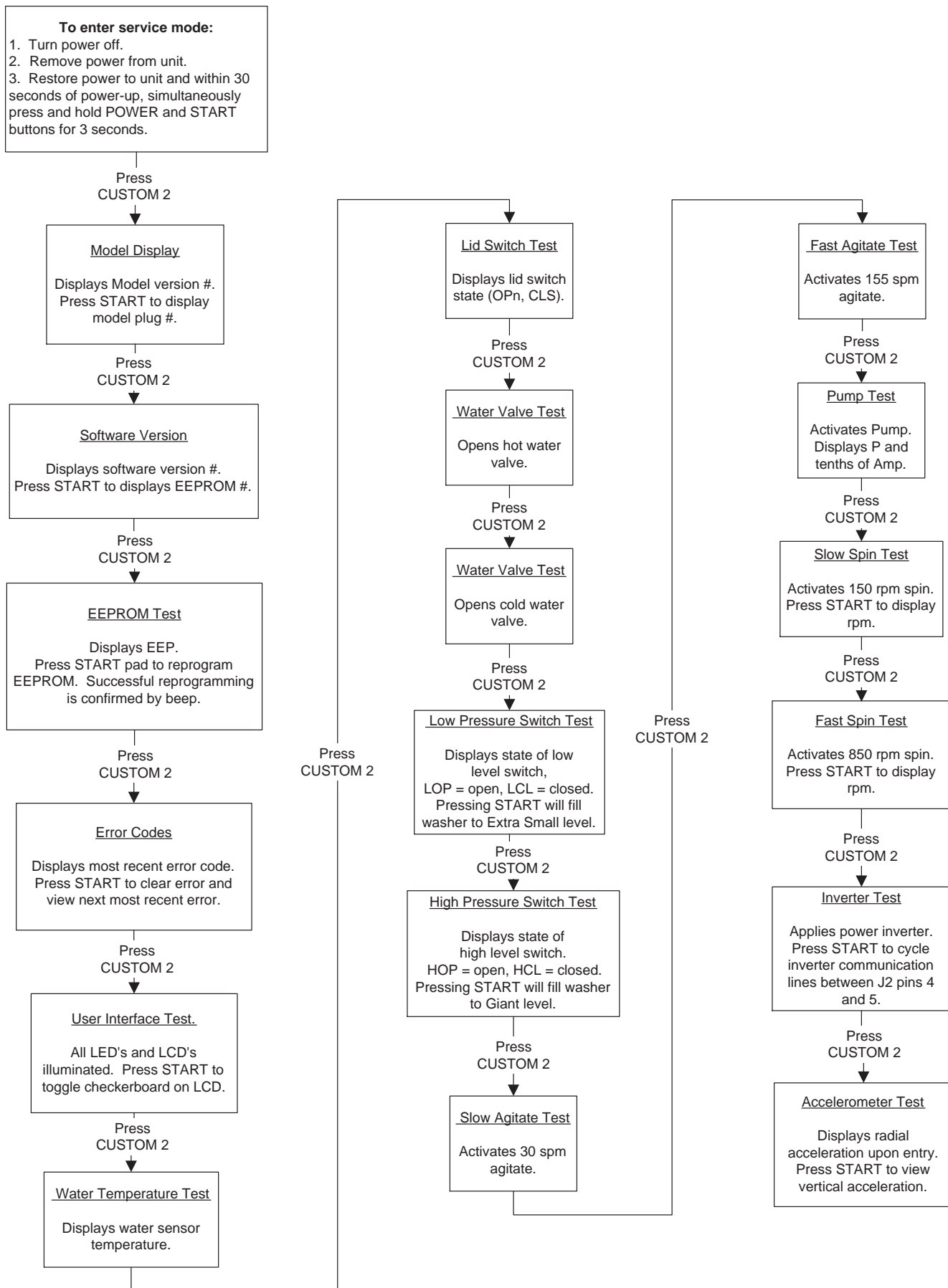

Note: A detailed definition of each service mode function can be found on the following pages.

Model Display Test:

Displays the model type (**Sr** or **Jr**) on the Digital Seven Segment Display (DSSD) upon entry. The washer will display the model and the model selector group number on the DSSD when the START pad is pressed and held during this test.

Software Version Number Test

Upon entering this test, the 3-digit software version number will be displayed on the DSSD. When the START pad is pressed and held, the appliance will display **E** and the 2-digit EEPROM version number on the DSSD.

Program EEPROM Test

Upon entering this test, **EEP** will be displayed on the Digital Seven Segment Display (DSSD). The appliance shall reprogram the EEPROM from flash if the START pad is pressed during the test. A (key press) beep will sound after successfully reprogramming EEPROM. The appliance shall display **Err** on the DSSD and sound a warning beep if the EEPROM cannot be reprogrammed.

Display Error Codes Test

Upon entering this test, the most recent error code recorded in the fault log will be displayed on the DSSD. If no errors are recorded in the fault log, **E00** will be displayed. Pressing the START pad will clear any displayed error codes from the fault log and will cause the next most recent error code recorded to be displayed.

After clearing all errors from the fault log, the appliance shall display **E00** on the DSSD.

User Interface Test:

Upon entering this test, all LED's and the LCD's (LCD models only) will be illuminated. The LCD model will turn on the LCD backlight and display a 1x1 checkerboard pattern upon entry. Pressing the START pad will scroll the LCD through the display patterns, as defined in the diagram below.

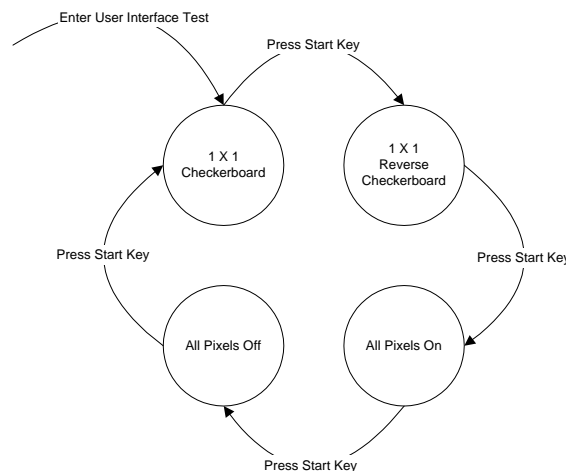

Water Temperature Test:

Upon entering this test, the water sensor temperature in degrees Fahrenheit will be displayed on the DSSD.

Lid Switch Test:

Upon entering this test, the lid switch state will be displayed on the DSSD. The washer shall display **OPn** on the DSSD if the switch is open during this test. The washer shall display **CLS** on the DSSD if the switch is closed during this test.

Hot Water Test:

Upon entering this test, the hot water valve will open and **Hot** will be displayed on the DSSD. The washer shall close the hot water valve as the Hot Water Test is exited.

Cold Water Test:

Upon entering this test, the cold water valve will open and **cld** will be displayed on the DSSD. Opens the cold water valve and displays **cld** on the DSSD upon entering. The washer shall close the cold water valve as the Cold Water Test is exited.

Low Pressure Switch Test:

The Low Pressure Switch Test will verify operation of the low pressure switch. Upon entering the test, the state of the low pressure switch will be displayed on the DSSD. The washer shall display **LOP** on the DSSD if the low pressure switch is open during this test. The washer shall display **LCL** on the DSSD if the low pressure switch is closed during this test.

Note:

- The low pressure switch is open when the water level is greater than the extra small fill level.
- The low pressure switch is closed when the water level is less than the extra small fill level.

If the START pad is pressed during this test, the washer will fill the tub with warm water until the low pressure switch is open.

If the low pressure switch and the high pressure switch indicate closed during this test, the washer will display the tub empty on the load size icon.

If the low pressure switch indicates open and the high pressure switch indicates closed during this test, the washer will display an extra small water level on the load size icon.

If the low pressure switch and the high pressure switch indicate open during this test, the washer will display a giant water level on the load size icon.

If the low pressure switch indicates closed and the high pressure switch indicates open during this test, the washer will turn on only the highest level on the load size icon.

The washer will turn off the hot water valve and the cold water valve as the test is exited.

High Pressure Switch Test:

The High Pressure Switch Test will verify operation of the high pressure switch. Upon entering the test, the state of the high pressure switch will be displayed on the DSSD. The washer shall display **HOP** on the DSSD if the high pressure switch is open during this test. The washer shall display **HCL** on the DSSD if the high pressure switch is closed during this test.

Note:

- The high pressure switch is open when the water level is greater than the giant fill level.
- The high pressure switch is closed when the water level is less than the giant fill level.

If the START pad is pressed during this test, the washer will fill the tub with warm water until the high pressure switch is open.

If both the low pressure switch and the high pressure switch indicate closed during this test, The washer shall display the tub empty on the load size icon.

If the low pressure switch indicates open and the high pressure switch indicates closed during this test, the washer shall display an extra small water level on the load size icon.

If both the low pressure switch and the high pressure switch indicate open during this test, the washer shall display a giant water level on the load size icon.

If the low pressure switch indicates closed and the high pressure switch indicates open during this test, the washer shall turn on only the highest level on the load size icon.

The washer shall turn off the hot water valve and the cold water valve as the test is exited.

Agitate Slow Test:

Upon entering this test, **AS** will be displayed on the DSSD and the washer will begin to agitate at 30 strokes per minute. The washer shall stop agitation as the test is exited.

Agitate Fast Test:

Upon entering this test, **AF** will be displayed on the DSSD and the washer will begin to agitate at 155 strokes per minute. The washer shall stop agitation as the test is exited.

Pump Test:

Upon entering this test, the pump will activate and a **P**, along with the pump current in tenths of amps will be displayed on the DSSD. For example, if the pump current is 0.9 amps, the washer shall display **P09** on the DSSD.

Spin Slow Test:

Upon entering this test, **SS** will be displayed on the DSSD and the washer will begin to spin at 150 rpm. If the START pad is pressed during this test, the spin rpm, as indicated from the speed sensor, will be displayed on the DSSD.

Spin Fast Test:

Upon entering this test, **SF** will be displayed on the DSSD and the washer will begin to spin at 850 rpm. If the START pad is pressed during this test, the spin rpm, as indicated from the speed sensor, will be displayed on the DSSD.

Inverter Test:

Upon entering this test, **SEr** will be displayed on the DSSD. Power will be applied to the inverter, and test signals will be sent on the inverter communication lines to provide a means to isolate a Power/Communication Error. If the START pad is pressed during this test, the washer will cycle the inverter communication lines (see figure below). Each time you touch START, you should toggle between a positive and negative voltage that should read greater than 1 volt.

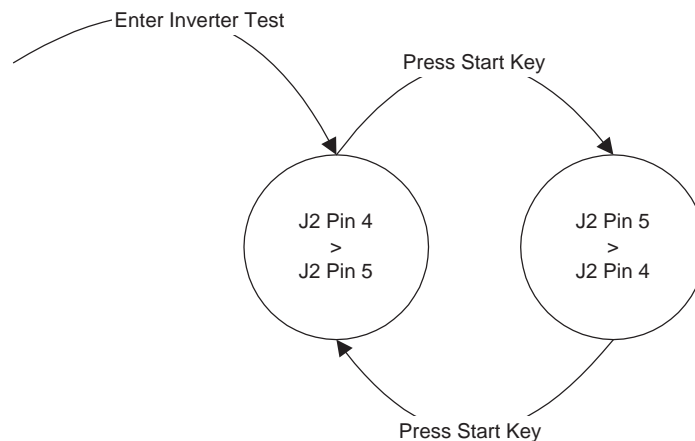

Accelerometer Test:

This test performs the signal integrity check, and displays vertical and radial acceleration on the DSSD. The washer will display the radial peak-to-peak acceleration upon entry, and will toggle between displaying radial acceleration and vertical acceleration each time the START pad is pressed.

The washer shall display radial acceleration in tenths of G's with a preceding **r**, for radial, on the DSSD. For example, a radial acceleration of 0.8 g's would be displayed as **r08**. If the radial acceleration fails the signal integrity check, the washer shall display **rbd** (radial bad).

The washer shall display the vertical acceleration in tenths of G's with a preceding **u**, for up, on the DSSD. For example, a vertical acceleration of 0.8 g's would display **u08**. If the vertical acceleration fails the signal integrity check, the washer shall display **ubd**, for up bad.

Note: See Accelerometer for instruction on performing this test.

Error Codes

Error Codes

Refer to the steps below to check error codes. Refer to the Error Codes Table for a listing and description of all error codes and the procedure to correct the error.

To check error codes:

1. Enter Service Mode.
2. Index to the Error Codes function using the CUSTOM 1 pad.
 - If no errors are present, E00 will be displayed on the DSSD.
 - If an error code is present, the error code will display immediately. If there is more than one error, pressing START will clear the displayed error code from the fault log and cause the next most recent error to be displayed.

To clear all error codes, continue to press the START pad while in the Error Codes function.

Note: Clear all error codes before exiting service mode

Error Codes Table

Error Code	Component	Description	Procedure
E10	EOL	EOL Water Inlet Test	Code not cleared at "End Of Line" factory test, clear error and continue
E11	EOL	EOL Agitation Test Incomplete	Code not cleared at "End Of Line" factory test, clear error and continue
E12	EOL	EOL Drain Test Incomplete	Code not cleared at "End Of Line" factory test, clear error and continue
E13	EOL	EOL Spin Test Incomplete	Code not cleared at "End Of Line" factory test, clear error and continue
E20	Fill System	Low Level Pressure Switch Error	Check pressure switch, pressure hose, wiring or control
E21	Fill System	High Level Pressure Switch Error	Check pressure switch, pressure hose, wiring or control
E30	Drive System	Clog Detected	Check drain pump, drain line
E31	Drive System	Pump Timeout	Check for pump clog, drain line, pressure switch
E32	Drive System	Pump Current Detection Circuit Error	Check pump current in Service Mode (page 37). Normal is 1.5 to 3.5 amps
E40	Drive System	VSD (Variable Speed Drive) Health Error	Check if washer can spin and agitate. If not, check for 5 VDC between black and white at inverter connector CN9. Replace inverter if present.
E41	Drive System	VSD Power/Communication Error	Check inverter power supply, wiring or control.
E42	Drive System	VSD (Variable Speed Drive)	Check wiring and make sure all ground connections are good, especially the braided cable between base and motor platform.
E43	Drive System	Excessive Brake Time	Check brake. Check speed sensor if brake check OK.
E46	Drive System	VSD No Speed Signal	Check speed sensor, wiring, or control
E47	Drive System	VSD (Variable Speed Drive) Heat Sink Over Temperature	Check inverter, could have been a very large load or jammed agitator in wash cycle
E48	Drive System	VSD Motor Short Circuit	Check motor resistance, check inverter to motor harness.
E49	Drive System	VSD (Variable Speed Drive) Drive Overload	Check inverter, could have been a very large load or jammed agitator in wash cycle
E4A	Drive System	VSD (Variable Speed Drive) Line Voltage Failure	Check inverter power, could be loose power connection at outlet, at control, or at inverter.
E4B	Drive System	VSD (Variable Speed Drive) Drive Reset	Low voltage (most likely cause is a brownout). Check whether washer can agitate and spin under a large load.
E4C	Drive System	VSD (Variable Speed Drive) Temperature Sensor Failure	Check inverter, could have been a very large load or jammed agitator in wash cycle
E4D	Drive System	VSD (Variable Speed Drive) Ram Error	Check inverter, could have been a very large load or jammed agitator in wash cycle
E50	Electronic Control	EEPROM Read/Write Failure	Try to reprogram EEPROM in Service Mode (see page 37). If EEPROM will not reprogram, replace control
E60	Sensors	Lid Switch Error	Check lid switch, wiring or control
E61	Sensors	Speed Sensor Error	Check speed sensor, magnets, wiring or control.
E62	Sensors	Lid Lock Error	Check lid lock, speed sensor, wiring or control
E63	Sensors	Excessive Radial Acceleration	Code not cleared at "End Of Line" factory test, clear error and continue
E64	Sensors	Excessive Axial Acceleration	Code not cleared at "End Of Line" factory test, clear error and continue
E65	Sensors	Accelerometer No Signal Error	Check accelerometer, wiring, or control
E66	Sensors	Water Temperature Sensor Open	Check thermistor, wiring, or control
E67	Sensors	Water Temperature Sensor Short	Check thermistor, wiring, or control

Note: VSD = Inverter

Troubleshooting Guide

PERFECTEMP PLUS	Possible Causes	What To Do	
PerfectTemp Plus wash temperature is incorrect (Review PerfectTemp Plus in the About washer features section)	The washer is in a cold rinse cycle	<ul style="list-style-type: none"> This is normal. The PerfectTemp Plus feature is designed not to activate during a cold rinse cycle to improve the energy efficiency of your washer. 	
	All the water in the household water heater has been used	<ul style="list-style-type: none"> Wait until the water in the water heater is heated to the correct temperature. 	
PERFORMANCE	Possible Causes	What To Do	
Clothes too wet	Incorrect spin speed selected	<ul style="list-style-type: none"> Make sure the spin cycle selected matches the load you are washing. Some fabrics will feel wetter when rinsed with cold water. 	
	Colored spots	<ul style="list-style-type: none"> Check fabric softener package for instructions and follow directions for using dispenser. Pretreat stain and rewash. 	
Grayed or yellowed clothes	Dye transfer	<ul style="list-style-type: none"> Sort whites or lightly colored items from dark colors. 	
	Not enough detergent	<ul style="list-style-type: none"> Use more detergent (especially with larger loads). Be sure to follow detergent manufacturer's directions. 	
	Hard water	<ul style="list-style-type: none"> Use a water conditioner like Calgon brand or install a water softener. 	
	Water is not hot enough	<ul style="list-style-type: none"> Make sure water heater is delivering water at 120°F–140°F (48°C–60°C). 	
	Washer is overloaded	<ul style="list-style-type: none"> Select load size to match clothes load. 	
	Detergent is not dissolving	<ul style="list-style-type: none"> Add detergent as wash basket fills with water before you load clothes. 	
Lint or residue on clothes	Dye transfer	<ul style="list-style-type: none"> Sort clothes by color. If fabric label states <i>wash separately</i>, unstable dyes may be indicated. 	
	Clothes are air or line dried	<ul style="list-style-type: none"> If you do not dry your clothes with a clothes dryer, your clothes may retain more lint. 	
	Incorrect sorting	<ul style="list-style-type: none"> Separate lint producers from lint collectors. 	
	Washing too long	<ul style="list-style-type: none"> Wash small loads for a shorter time than larger loads. 	
	Detergent not dissolving		<ul style="list-style-type: none"> Add detergent as wash basket fills with water, before you load clothes.
			<ul style="list-style-type: none"> Try a liquid detergent.
			<ul style="list-style-type: none"> Use warmer water temperature.
	Overloading		<ul style="list-style-type: none"> Load clothes no higher than the top row of holes in the washer basket.
			<ul style="list-style-type: none"> Make sure load size selected matches clothes load size.
	Incorrect use of fabric softener		<ul style="list-style-type: none"> Check fabric softener package for instructions and follow directions for using dispenser.
Wash speed is too fast		<ul style="list-style-type: none"> Choose a wash cycle with a slower wash speed. 	

PERFORMANCE (cont.)	Possible Causes	What To Do
Pilling	Result of normal wear on poly-cotton blends and fuzzy fabrics	<ul style="list-style-type: none"> • While this is not caused by the washer, you can slow the pilling process by washing garments inside out.
Snags, holes, tears, rips or excessive wear	Pins, snaps, hooks, sharp buttons, belt buckles, zippers and sharp objects left in pockets	<ul style="list-style-type: none"> • Fasten snaps, hooks, buttons and zippers. • Remove loose items like pins, objects in pockets and sharp buttons. • Turn knits (which snag easily) inside out.
	Undiluted chlorine bleach	<ul style="list-style-type: none"> • Check bleach package instructions for proper amount. • Never add undiluted bleach to wash or allow clothes to come in contact with undiluted bleach.
	Chemicals like hair bleach or dye, permanent wave solution	<ul style="list-style-type: none"> • Rinse items that may have chemicals on them before washing.
Wrinkling	Improper sorting	<ul style="list-style-type: none"> • Avoid mixing heavy items (like work clothes) with light items (like blouses). • Try a fabric softener.
	Overloading or incorrect water level	<ul style="list-style-type: none"> • Load your washer so clothes have enough room to move freely with water covering all of the clothes.
	Incorrect wash and dry cycles	<ul style="list-style-type: none"> • Match Cycle selection to the type of fabric you are washing (especially for easy care loads).
	Repeated washing in water that is too hot	<ul style="list-style-type: none"> • Wash in warm or cold water.

OPERATION	Possible Causes	What To Do
Washer pauses in cycle	The ULTRA HANDWASH, DELICATES or CASUALS cycle was chosen	<ul style="list-style-type: none"> • This is normal. The washer alternates between agitate and soak during the ULTRA HANDWASH, DELICATES and CASUALS cycles to get your clothes cleaner with less wear.
	The highest SOIL LEVEL setting was chosen	<ul style="list-style-type: none"> • The highest SOIL LEVEL setting adds a 15 minute Stain Wash agitate and soak period at the beginning of the wash cycle.
Washer won't operate	Control panel is asleep	<ul style="list-style-type: none"> • This is normal. Press POWER to activate the control panel.
	Washer is unplugged	<ul style="list-style-type: none"> • Make sure cord is plugged securely into a working outlet.
	Water supply is turned off	<ul style="list-style-type: none"> • Turn both hot and cold faucets fully on.
	Controls are not set properly	<ul style="list-style-type: none"> • Check controls.
	Lid is open—safety feature prevents agitation and spinning when lid is up.	<ul style="list-style-type: none"> • Close lid and reset cycle, to the beginning if necessary.
	Circuit breaker/fuse is tripped/blown	<ul style="list-style-type: none"> • Check house circuit breakers/fuses. Replace fuses or reset breaker. Washer should have separate outlet.
	Electronics need to be reset	<ul style="list-style-type: none"> • Unplug washer, wait 2 minutes, plug back in and press POWER.
	START was not pressed	<ul style="list-style-type: none"> • Press START.
	Extremely low water pressure	<ul style="list-style-type: none"> • Press START again.
Washer was accidentally paused when starting Delay Start	<ul style="list-style-type: none"> • If the light on the DELAY START pad is flashing, the washer is paused. Press START to restart the countdown. 	

WATER	Possible Causes	What To Do
Too many suds	Type of detergent	<ul style="list-style-type: none"> • Switch to a lower sudsing detergent brand and follow instructions on package.
	Very soft water	<ul style="list-style-type: none"> • Try less detergent.
	Too much detergent	<ul style="list-style-type: none"> • Measure your detergent carefully. Use less soap if you have soft water, a smaller load or a lightly soiled load.
Water leaks	Fill hoses or drain hose is improperly connected	<ul style="list-style-type: none"> • Make sure hose connections are tight at faucets and at washer. • Make sure end of drain hose is properly connected to washer and correctly inserted in and secured to drain facility.
	Household drain may be clogged	<ul style="list-style-type: none"> • Check household plumbing. You may need to call a plumber.
	Constant water pressure to the fill hoses at the water source	<ul style="list-style-type: none"> • Tighten hoses at the faucets and turn the water off after each use. • Check condition of the fill hoses; they should be replaced every 5 years.
	Using too much detergent in washer	<ul style="list-style-type: none"> • Use less detergent. Use less soap if you have soft water, a smaller load or a lightly soiled load.
Water temperature is incorrect	Control is not set properly	<ul style="list-style-type: none"> • Check water temperature control and adjust.
	Water supply is turned off or improperly connected	<ul style="list-style-type: none"> • Turn both hot and cold faucets fully on and make sure hoses are connected to correct faucets.
	Water valve screens are stopped up	<ul style="list-style-type: none"> • Turn off the water source and disconnect water fill hoses from the upper back of the washer. Use a brush or toothpick to clean the screens in the machine. Reconnect the hoses and turn the water back on.
	House water heater is not set properly	<ul style="list-style-type: none"> • Make sure house water heater is delivering water at 120°F–140°F (48°C–60°C).
	PerfectTemp Plus feature was not activated	<ul style="list-style-type: none"> • The lid must be closed for PerfectTemp Plus to work.
Water pumped out before cycle is complete	Lid lifted or cycle was put in pause for over 24 hours	<ul style="list-style-type: none"> • Reset cycle.
Water won't drain	Drain hose is kinked or improperly connected	<ul style="list-style-type: none"> • Straighten drain hose and make sure washer is not sitting on it. • Top of drain outlet should be less than 8 ft (2.5 m) above floor.
Water spraying during spin cycle	Washer in spin cycle	<ul style="list-style-type: none"> • Spray rinse during a spin cycle is normal.
Washer did not fill to chosen level	Extremely low water pressure	<ul style="list-style-type: none"> • Press the START button again.
	Inlet hoses are kinked	<ul style="list-style-type: none"> • Straighten hoses.
	Water valve screens are stopped up	<ul style="list-style-type: none"> • Turn off the water source and disconnect water fill hoses from the upper back of the washer. Use a brush or toothpick to clean the screens in the machine. Reconnect the hoses and turn the water back on.
Water fills and drains at the same time	Drain stand pipe is too low	<ul style="list-style-type: none"> • Drain stand pipe must be above 30" (76.2 cm).

NOISE	Possible Causes	What To Do
Washer is noisy	Washer is uneven	<ul style="list-style-type: none"> To level the front of the washer, adjust the front leveling legs by rotating the individual leg in the proper direction for up or down. To level back of washer, lift back of machine 4" (11 cm) and set down.
	Washer load is unbalanced	<ul style="list-style-type: none"> Press START to pause the washer, open the lid and redistribute the load evenly. Close the lid and press START again.
	Shipping rod is still assembled in unit	<ul style="list-style-type: none"> To remove shipping rod from washer, pull yellow tag and attached rod from the bottom right hand side of washer.
	Washer is sitting too close to wall (causes knocking during cycle)	<ul style="list-style-type: none"> Pull washer away from the wall; about 4" (11 cm) is needed.
	PerfectTemp Plus feature is being used	<ul style="list-style-type: none"> This is normal. PerfectTemp Plus turns water valves off and on to adjust water temperature.
OTHER	Possible Causes	What To Do
Labels on the exterior of the washer will not peel off cleanly	Occasionally the adhesive used on the labels does not release cleanly	<ul style="list-style-type: none"> Use a hair dryer set at the lowest heat setting, directing the air at the label for a short amount of time. This will release the adhesive easily, without damaging the surface of the washer.

Problem Chart

Error Reported	Possible Problem	Probable Cause and Action
Leak reported.	Unit has a leak that cannot be found.	Tub cover/floodhead faulty. Replace if necessary.
Leak reported.	Soap suds overflowing the tub cover.	The user added too much detergent to the washer. Use less detergent.
The washer is making a clicking sound.	Faulty lid switch.	Faulty lid switch or lid switch wiring. Refer to Lid Switch Diagnostic.
The washer is making a clicking sound.	Low voltage at plug.	Too many devices plugged into the same outlet, or an extension cord is being used to operate the machine. Use an individual circuit.
The washer is making a clicking sound.	Faulty pressure switch connection.	Bad connection at pressure switch or 12-pin connector. Reconnect/retighten connection.
Washer is not spinning.	Faulty lid switch.	Faulty lid switch or lid switch wiring. Refer to Lid Switch Diagnostic.
Washer is not spinning.	Faulty pressure switch connection.	Bad connection at pressure switch or 12-pin connector. Reconnect/retighten connection.
Washer is not spinning.	Blocked pressure hose. Faulty pressure switch.	Pressure switch will not reset. Check pressure hose for blockage. If OK, replace pressure switch.
Washer is not spinning.	Faulty motor or inverter.	See Motor Does Not Operate Diagnostic flowchart.
Washer is not agitating.	Faulty lid switch.	Faulty lid switch or lid switch wiring. Refer to Lid Switch Diagnostic.
Washer is not agitating.	Faulty pressure switch connection.	Bad connection at pressure switch or 12-pin connector. Reconnect/retighten connection.
Washer is not agitating.	Blocked pressure hose. Faulty pressure switch.	Pressure switch will not reset. Check pressure hose for blockage. If OK, replace pressure switch.
Washer is not agitating.	Faulty motor or inverter.	See Motor Does Not Operate Diagnostic flowchart.
Control not responding.	Control locked up and cannot be accessed.	Noise spike on 120 VAC circuit. Unplug for 20 seconds to reset control and recheck.
Control not responding.	Damaged board.	Possible lightning strike causing damage to board. Inspect board for burn/scorch; replace if damage found.
Machine slows down during agitation.	Customer unaware of product features.	Machine has 105 stroke per minute slow agitate at the end of some cycles. This is normal operation.
Machine starts spin in slow speed, then switches to high.	Customer unaware of product features.	Machine starts spin in slow speed, then switches to the customer-selected speed. Normal operation.

Schematic

