

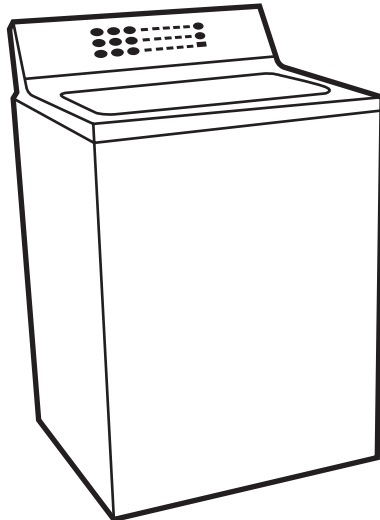

TECHNICAL SERVICE GUIDE

Variable Speed Washer



MODEL SERIES:

WHSB9000B
WNSB9100B
WPSB9080B
WPSB9120B





IMPORTANT SAFETY NOTICE

The information in this service guide is intended for use by individuals possessing adequate backgrounds of electrical, electronic, and mechanical experience. Any attempt to repair a major appliance may result in personal injury and property damage. The manufacturer or seller cannot be responsible for the interpretation of this information, nor can it assume any liability in connection with its use.

WARNING

To avoid personal injury, disconnect power before servicing this product. If electrical power is required for diagnosis or test purposes, disconnect the power immediately after performing the necessary checks.

RECONNECT ALL GROUNDING DEVICES

If grounding wires, screws, straps, clips, nuts, or washers used to complete a path to ground are removed for service, they must be returned to their original position and properly fastened.

GE Consumer Home Services Training
Technical Service Guide
Copyright © 2001

All rights reserved. This service guide may not be reproduced in whole or in part in any form without written permission from the General Electric Company.

Table of Contents

Nomenclature	3
Serial Number	3
Cycle Chart	4
Control Panel Features	5
Washer Control Panels	5
One Touch Selections	6
Clothes Care Cycles	7
Control Features	8
Cycle Options	9
Cycle Status	9
Normal Operating Sounds	10
Component Locator Views	12
Washer Components	13
Control Panel	13
Electronic Control Board	13
Control Filter	14
Front Panel	14
Cover/Lid Assembly	14
Legs	15
Agitator	15
Water Valve/Automatic Temperature Control	15
Water Level Switch	16
Water Level (Load Size) Diagnostic	17
Lid Switch	17
Lid Switch Diagnostic	18
Inverter	18
Choke	18
Motor	19
Motor Tachogenerator Test	19
Drive Belt	20
Drain Pump	20
Suspension	21
Spin Basket	21
Tub With Motor and Transmission	22
Transmission	23
Schematic	24
Field Service Mode and Error Codes	25
Motor Does Not Operate Diagnostic	28
Problem Chart	30

Table of Contents (cont.)

Troubleshooting Guide	31
Review	36
Warranty	37

Nomenclature

W H S B 9 0 0 0 B W W

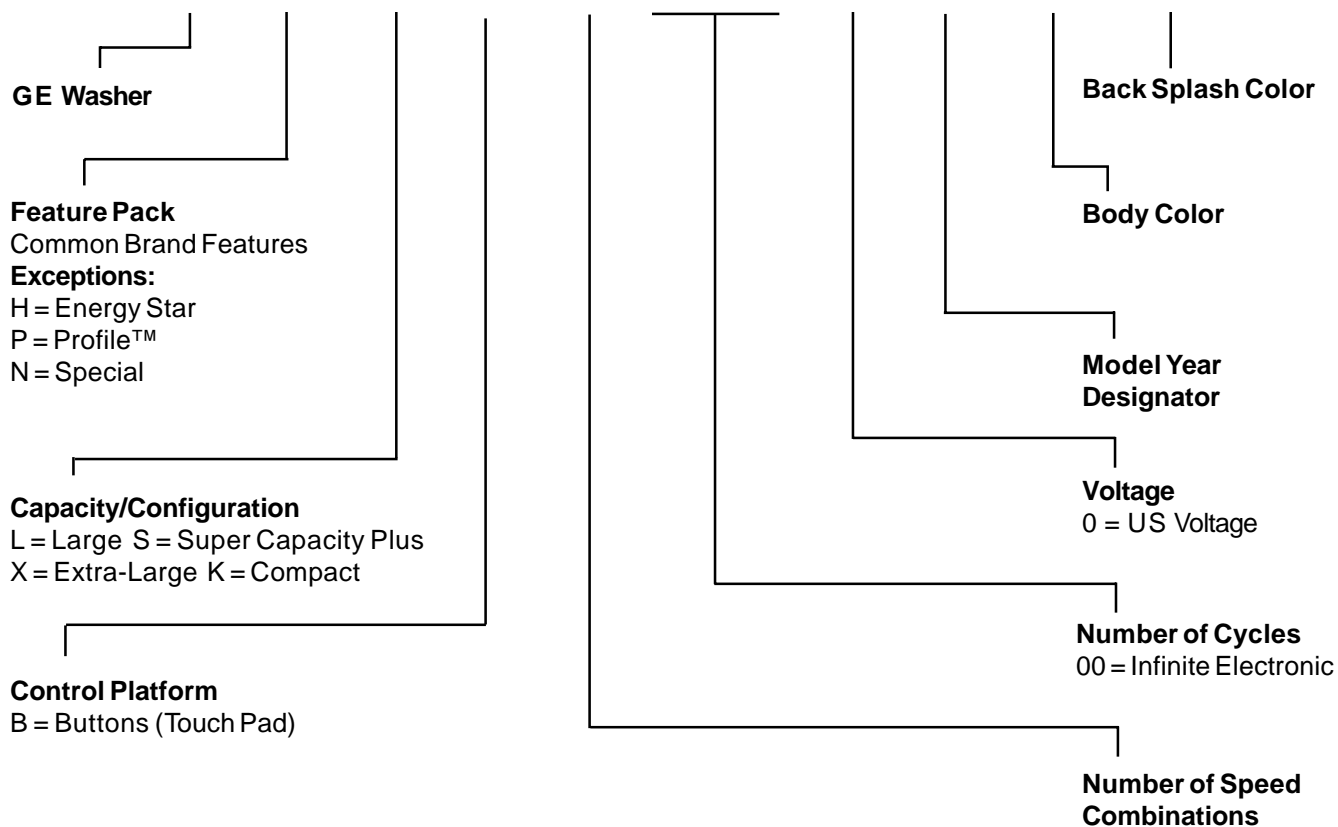

Serial Number



The first two characters of the serial number identify the month and year of manufacture.

Example: AA123456S = January, 2001

A - JAN	2005 - H
D - FEB	2004 - G
F - MAR	2003 - F
G - APR	2002 - D
H - MAY	2001 - A
L - JUN	2000 - Z
M - JUL	1999 - V
R - AUG	1998 - T
S - SEP	1997 - S
T - OCT	1996 - R
V - NOV	1995 - M
Z - DEC	1994 - L

The letter designating the year repeats every 12 years.

Example:

T - 1974
T - 1986
T - 1998

Note: Model number and serial number are located on rear of backsplash.

- The technical sheet is located under the control panel.

Cycle Chart

Feature Cycles	Load	Soil Level LED Time Minutes	Wash/Rinse Temperature	Speed (wash/spin)	Options	Stain Wash	Heavy Agitation Time and Speed	Medium Agitation Time and Speed	Light Agitation Time and Speed	Extra Light Agitation Time and Speed	Wash Spin Time	Spray Rinse (wash cycle)	Rinse Agitation Time	2nd Rinse Agitation Time	2nd Rinse Spin Time	Final Spin	*Extended Spin	Spray Rinse (rinse cycle)
White/Hot	Large	Normal	Hot/Cold	155 spm/ 630 rpm	None	Note 1	15 min @ 155 spm 3 min @ 106 spm	12 min @ 155 spm 3 min @ 106 spm	9 min @ 155 spm 3 min @ 106 spm	6 min @ 155 spm 3 min @ 106 spm	3 min	-	3 min @ 155 spm	3 min @ 155 spm	3 min	8 min	8 min	Yes
Colors/Warm	Large	Normal	Warm/Cold	155 spm/ 630 rpm	None	Note 1	15 min @ 155 spm 3 min @ 106 spm	12 min @ 155 spm 3 min @ 106 spm	9 min @ 155 spm 3 min @ 106 spm	6 min @ 155 spm 3 min @ 106 spm	3 min	-	3 min @ 155 spm	3 min @ 155 spm	3 min	8 min	8 min	Yes
Dark Colors/ Cold	Large	Normal	Cold/Cold	106 spm/ 630 rpm	None	Note 1	18 min @ 106 spm	15 min @ 106 spm	12 min @ 106 spm	9 min @ 106 spm	3 min	-	3 min @ 106 spm	3 min @ 106 spm	3 min	8 min	8 min	Yes
Easy Care Perm Press	Large	Normal	Warm/Cold	106 spm/ 630 rpm	None	Note 1	18 min @ 106 spm	15 min @ 106 spm	12 min @ 106 spm	9 min @ 106 spm	3 min	Yes	3 min @ 106 spm	3 min @ 106 spm	3 min	6 min	6 min	Yes
Hand Wash	Small	Light	Cold/Cold	30 spm/ 350 rpm	None	Note 1	18 min @ 30 spm	15 min @ 30 spm	12 min @ 30 spm	9 min @ 30 spm	3 min	Yes	3 min @ 30 spm	3 min @ 30 spm	3 min	6 min	6 min	-
Speed Wash	Small	Light	Warm/Warm	155 spm/ 630 rpm	None	Note 1	6 min @ 155 spm	5 min @ 155 spm	4 min @ 155 spm	3 min @ 155 spm	2 min	-	1-1/2 min @ 155 spm	1-1/2 min @ 155 spm	1 min	3 min	3 min	-
Presoak	Large	See note 3 (normal)	Warm/Warm	155 spm	None	-	3 min @ selected agitate speed 12 min soak	-	-	-	-	-	-	-	-	-	-	-
Presoak With Another Cycle	See note 4	See note 4	See note 4	See note 4	None	-	See note 4	See note 4	See note 4	See note 4	-	-	-	-	-	-	-	-
Quick Rinse	Large	-	Cold/Cold	106 spm/ 630 rpm	None	-	-	-	-	-	-	-	3 min @ 106 spm	3 min @ 106 spm	3 min	6 min	6 min	-
Drain & Spin	-	-	-	106 spm/ 630 rpm	None	-	-	-	-	-	-	-	-	-	-	6 min	6 min	-
White Cottons	Large	Normal	Hot/Cold	155 spm/ 630 rpm	None	Note 1	15 min @ 155 spm 3 min @ 106 spm	12 min @ 155 spm 3 min @ 106 spm	9 min @ 155 spm 3 min @ 106 spm	6 min @ 155 spm 3 min @ 106 spm	3 min	-	3 min @ 155 spm	3 min @ 155 spm	3 min	8 min	8 min	Yes
Colored Cottons	Large	Normal	Warm/Cold	155 spm/ 630 rpm	None	Note 1	15 min @ 155 spm 3 min @ 106 spm	12 min @ 155 spm 3 min @ 106 spm	9 min @ 155 spm 3 min @ 106 spm	6 min @ 155 spm 3 min @ 106 spm	3 min	-	3 min @ 155 spm	3 min @ 155 spm	3 min	8 min	8 min	Yes
Towels	Super	Light	Warm/Cold	155 spm/ 630 rpm	Extra Spin	Note 1	15 min @ 155 spm 3 min @ 106 spm	12 min @ 155 spm 3 min @ 106 spm	9 min @ 155 spm 3 min @ 106 spm	6 min @ 155 spm 3 min @ 106 spm	3 min	-	3 min @ 155 spm	3 min @ 155 spm	3 min	8 min	8 min	Yes
Sheets	Super	Normal	Hot/Cold	155 spm/ 630 rpm	None	Note 1	15 min @ 155 spm	12 min @ 155 spm	9 min @ 155 spm	6 min @ 155 spm	3 min	-	3 min @ 155 spm	3 min @ 155 spm	3 min	8 min	8 min	Yes
Jeans	Large	Heavy	Warm/Cold	155 spm/ 630 rpm	None	Note 1	18 min @ 155 spm	15 min @ 155 spm	12 min @ 155 spm	9 min @ 155 spm	3 min	-	3 min @ 155 spm	3 min @ 155 spm	3 min	8 min	8 min	Yes
Play Clothes	Large	Heavy	Warm/Cold	155 spm/ 630 rpm	Autosoak 15 min	Note 1	12 min @ 155 spm 6 min @ 106 spm	9 min @ 155 spm 6 min @ 106 spm	6 min @ 155 spm 6 min @ 106 spm	3 min @ 155 spm 6 min @ 106 spm	3 min	-	3 min @ 155 spm	3 min @ 155 spm	3 min	8 min	8 min	Yes
Khakis	Large	Normal	Warm/Cold	106 spm/ 630 rpm	None	Note 1	15 min @ 106 spm	12 min @ 106 spm	9 min @ 106 spm	6 min @ 106 spm	3 min	Yes	3 min @ 106 spm	3 min @ 106 spm	3 min	6 min	6 min	Yes
Shirt/Blouses	Large	Normal	Warm/Cold	80 spm/ 450 rpm	None	Note 1	18 min @ 80 spm	15 min @ 80 spm	12 min @ 80 spm	9 min @ 80 spm	3 min	Yes	3 min @ 80 spm	3 min @ 80 spm	3 min	6 min	6 min	Yes
Sweaters	Medium	Normal	Cold/Cold	30 spm/ 350 rpm	Extra Spin	Note 1	18 min @ 30 spm	15 min @ 30 spm	12 min @ 30 spm	9 min @ 30 spm	3 min	-	3 min @ 30 spm	3 min @ 30 spm	3 min	6 min	6 min	Yes
Lingerie/Ultra Handwash	Small	Light	Cold/Cold	30 spm/ 350 rpm	None	Note 1	5 min @ 30 spm 3 min @ 30 spm 3 min @ 30 spm 5 min @ 30 spm	4 min @ 30 spm 3 min @ 30 spm 3 min @ 30 spm 4 min @ 30 spm	3 min @ 30 spm 3 min @ 30 spm 3 min @ 30 spm 3 min @ 30 spm	2 min @ 30 spm 3 min @ 30 spm 3 min @ 30 spm 2 min @ 30 spm	3 min	-	3 min @ 30 spm	3 min @ 30 spm	3 min	4 min	4 min	Yes

* Extended spin time is in addition to final spin time.

1. Stain wash: 3 min. agitation, 12 min. soak, 1 min. agitation, 14 min. soak, and then run the cycle selected at the heavy soil setting.

2. N/A

3. Soak Cycle: 3 min. agitation and then soak. Drain & spin will occur automatically 24 hours after fill. Interrupt soak using another cycle, such as drain and spin.

4. Presoak: 3 min. agitation at selected speed, 12 min. soak, and cycle selected. Presoak is selected with any other cycle after the cycle is selected.

Control Panel Features

Washer Control Panels

Model WHSB9000B

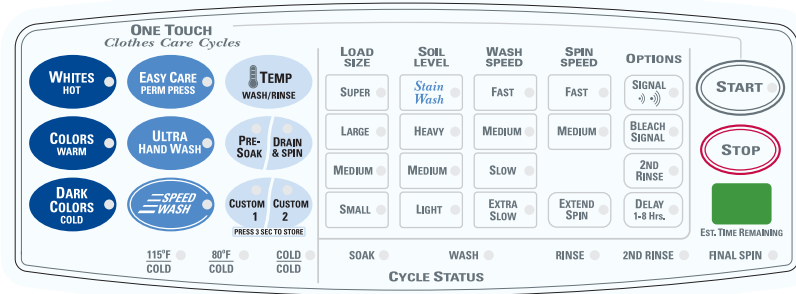

Model WPSB9080B

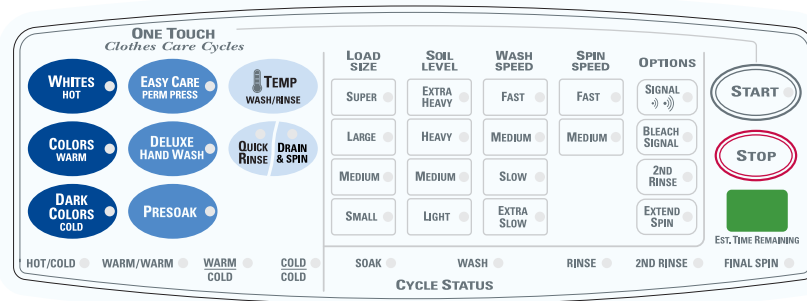

Model WNSB9100B

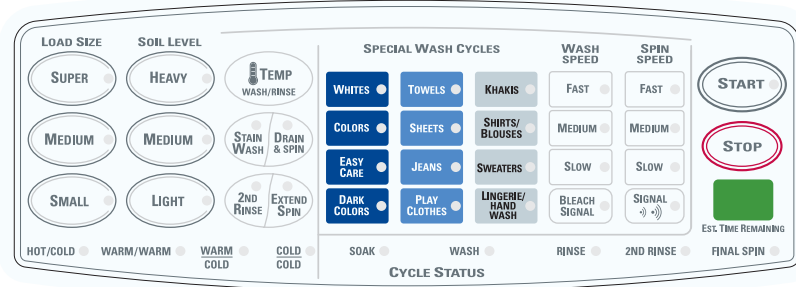

Model WPSB9120B

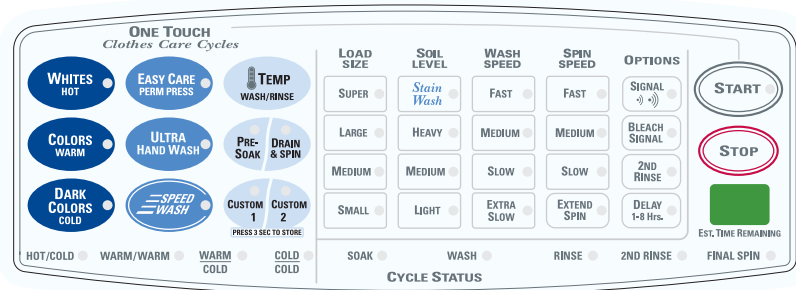

One Touch Selections

Model WHSB9000

PRESS...

AUTOMATICALLY SELECTS...

THEN PRESS...



LOAD SIZE	SOIL LEVEL	WASH SPEED	SPIN SPEED	TEMP WASH/RINSE
LARGE ●	MEDIUM ●	FAST ●	FAST ●	115°F COLD ●



For heavy to lightly soiled cottons, household linens, work and play clothes.



LARGE ●	MEDIUM ●	FAST ●	FAST ●	80°F COLD ●
---------	----------	--------	--------	-------------



For heavy to lightly soiled cottons, household linens, work and play clothes.



LARGE ●	MEDIUM ●	MEDIUM ●	FAST ●	COLD COLD ●
---------	----------	----------	--------	-------------



For non-colorfast cottons and blends, and items that are labeled cold wash by the fabric manufacturer.



LARGE ●	MEDIUM ●	MEDIUM ●	FAST ●	80°F COLD ●
---------	----------	----------	--------	-------------



For knits, wrinkle-free and permanent press items.



SMALL ●	LIGHT ●	EXTRA SLOW ●	MEDIUM ●	COLD COLD ●
---------	---------	--------------	----------	-------------



For lingerie and items labeled hand-washable with light soils. Provides periods of agitation and soak during wash and rinse.



SMALL ●	LIGHT ●	FAST ●	FAST ●	80°F COLD ●
---------	---------	--------	--------	-------------



For lightly soiled items that are needed in a hurry. Cycle time is approximately 15 minutes, depending on your household water pressure.

Clothes Care Cycles

SOIL LEVEL

Stain Wash

STAIN WASH (on some models)

For heavily soiled or stained items. Adds an extra agitation and soak at the beginning of the wash cycle.

PRE-SOAK

PRE-SOAK

Appearance may vary.

PRESOAK

To presoak a load and go straight into a wash cycle:

Select your wash cycle, press the **PRESOAK** pad, then press the **START** pad.

- Starts with three minutes of agitation, then 12 minutes of soaking, followed by the selected wash cycle.
- Uses the speed and water temperature of your selected wash cycle.

To presoak a load for more than 12 minutes:

Press the **PRESOAK** pad. The washer will fill. You may change the automatic settings if desired.

- Three minutes of agitation is followed by up to 24 hours of soaking.
- To soak less than 24 hours, press the **DRAIN & SPIN** pad or choose a wash cycle.

QUICK RINSE

QUICK RINSE (on some models)

Use this feature to quickly rinse chlorine, perspiration, stains, etc. out of clothes.

- The washer fills with water, agitates for three minutes, drains and spins. You may change the automatic settings if desired.

DRAIN & SPIN

DRAIN & SPIN

DRAIN & SPIN any cycle at any time.

CUSTOM 1 CUSTOM 2 PRESS 3 SEC TO STORE

CUSTOM 1 and CUSTOM 2 (on some models)

Set up your favorite combination of settings and save them here for one-touch recall.

These custom settings cannot be set while a cycle is in progress.

To store a custom combination of settings:

1. Select a **ONE TOUCH** setting.
2. Change **LOAD SIZE**, **SOIL LEVEL**, **TEMPERATURE**, **WASH SPEED** or **SPIN SPEED** to fit your needs.
3. Select any **OPTIONS** you want.
4. Press and hold the **CUSTOM 1** or **CUSTOM 2** pad until the washer beeps to store your selection.

To recall your stored combination:

Press the **CUSTOM 1** or **CUSTOM 2** pad, then press **START**.

NOTE: DELAY 1-8 HRS. cannot be used in **CUSTOM 1** and **CUSTOM 2** settings.

To reprogram the custom settings:

Repeat steps 1–4 above.

Control Features



START

- After you have selected a new cycle, press once to start the cycle.
- Press twice to select the last cycle used and start the washer.
- If the washer is running, press once to interrupt the cycle; press again to continue the cycle.



STOP

This pad should **not** be used to interrupt or pause a cycle.

Pressing this pad will cancel the current settings and the settings will be lost.



Estimated Time Remaining

- Displays the approximate time remaining until the end of the cycle.
- If the estimated time remaining is more than 60 minutes, “1H” will flash in the display, followed by the additional remaining minutes. When the time remaining is less than 60 minutes, the timer will count down.
- Cycle time is affected by how long it takes the washer to fill. This depends on the water pressure in your home. The “smart” timer “learns” the amount of time it takes to fill your washer and adjusts the total time accordingly.

NOTE: If **PRESOAK** is selected and a follow up wash cycle is not chosen, two dashes will come up in the display.

Spot Spray

Provides a short spray of water to allow you to dampen clothing when you pretreat stains.

- 1 Open the washer lid.
- 2 Press the **SPOT SPRAY** button. (You will see a short stream of water.)
- 3 Dampen your soiled garment with the **SPOT SPRAY** option and rub your favorite pretreatment product into soiled area.

NOTE: The **SPOT SPRAY** option will not work if

- the washer lid is down
- the washer tub is filling
- the water has already reached the level you selected.



BLEACH SIGNAL (on some models)

The Bleach Signal is a reminder signal that can be turned on to remind you to add bleach at the proper time in the wash cycle. Adding detergent and bleach at the same time reduces the effectiveness of both the enzymes in the detergent and the chlorine in the bleach. By adding bleach later in the wash cycle, you allow the detergent’s enzymes to remove dirt and stains first, and then provide a more effective dose of liquid bleach to whiten and sanitize your clothes.

Cycle Options



SIGNAL

Alerts you when the cycle is complete.

On some models, press **SIGNAL** to turn the beeper on or off.

On some models, press **SIGNAL** to select low or high volume, or to turn the beeper off.



2ND RINSE

Adds a second rinse to any cycle.



EXTEND SPIN

Extends the last spin of a wash cycle. This will extract more water from your clothes. Clothes will be drier when you use this option.



DELAY 1-8 HOURS (on some models)

Use to delay the start of your washer for 1 to 8 hours. First choose your wash cycle and any options. Then press this pad for the number of hours you want to delay the cycle. Press the **START** pad to start the countdown.

The countdown time will be shown in the **Est. Time Remaining** display.

PerfectTemp Plus ●

PerfectTemp Plus

PerfectTemp Plus senses the incoming water temperature and adjusts the temperature of the fill water.

The lid must be closed for **PerfectTemp Plus** to work.

If your water is too cold, detergent will not dissolve effectively and clothes may not get clean. If the water is too hot, fabrics could be damaged.

PerfectTemp Plus adjusts these water temperature extremes for better washing performance.

You may hear the water valves turning off and on while the water temperature is being adjusted. This is normal.

Normal Operating Sounds

The Profile washer uses an extremely quiet drive motor; therefore, normal operating sounds, not heard on previous models, may be noticed on this model. The most noticeable operating sound on this model may be from the transmission.

Component Locator Views

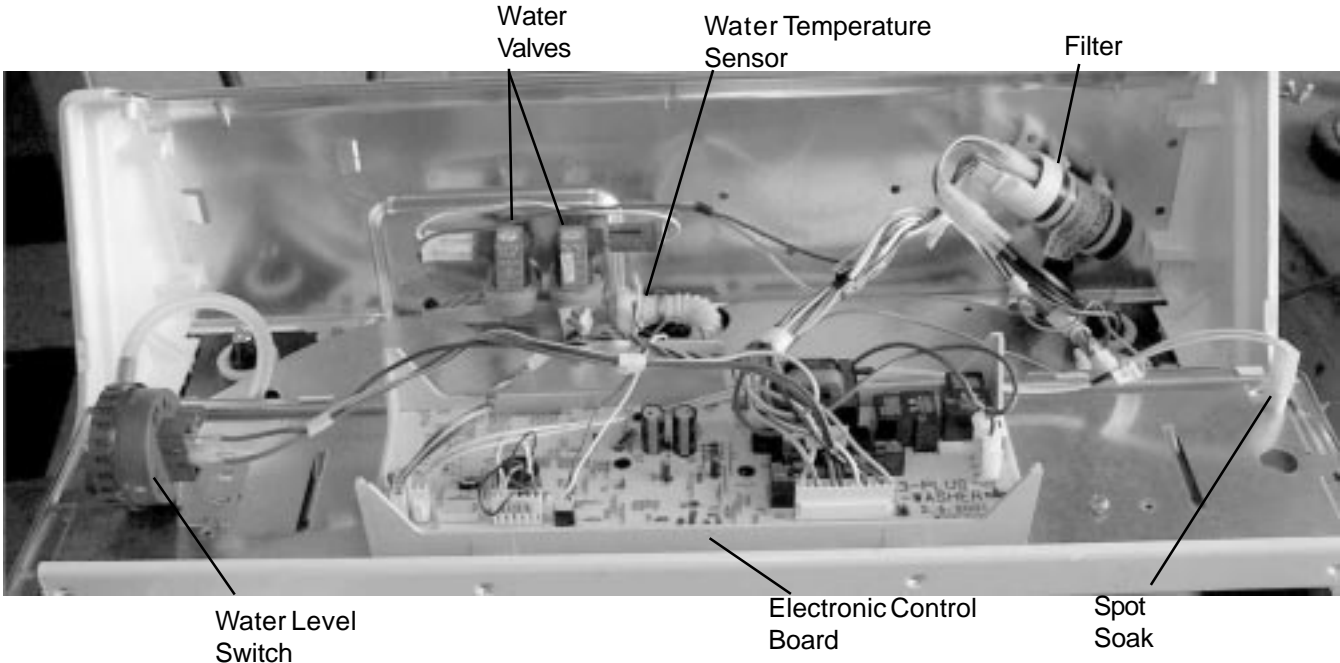
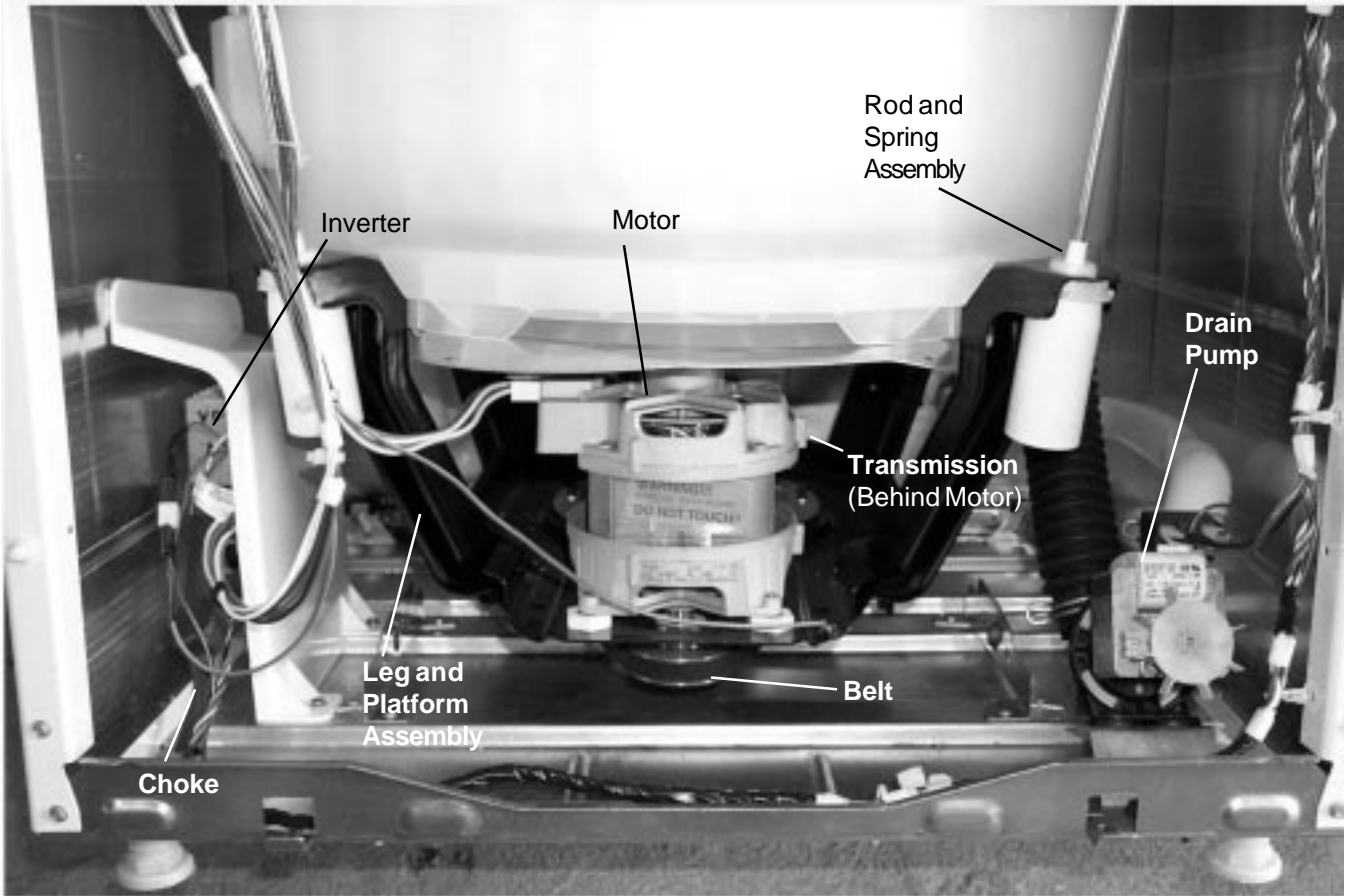

Washer Components

Control Panel

To place the control panel in the service position, remove 4 torx screws from the top of the backsplash and rotate the top forward.

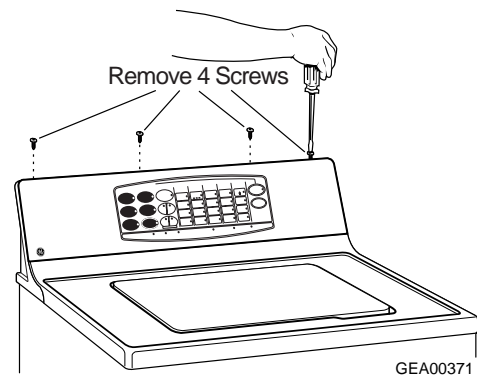

Electronic Control Board

The electronic control board is attached to the back of the control panel.

Note: If motor does not operate, perform Motor Does Not Operate Diagnostic before replacing electronic control board.

To remove the electronic control board:

1. Place the control panel in service position.
2. Disconnect the harness connections. Remove and retain the model selector harness plug for reassembly.
3. Remove 2 (1/4-in.) screws from the control board.

Caution: To prevent electrostatic discharge, ground yourself to the washer cabinet or use an ESD wristband.

4. Remove the electronic control board by gently lifting from position.

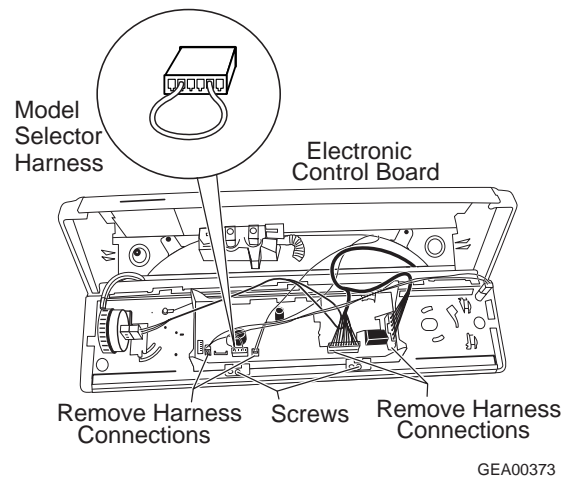

Note: When reassembling, align the LEDs with the appropriate control panel indicators.

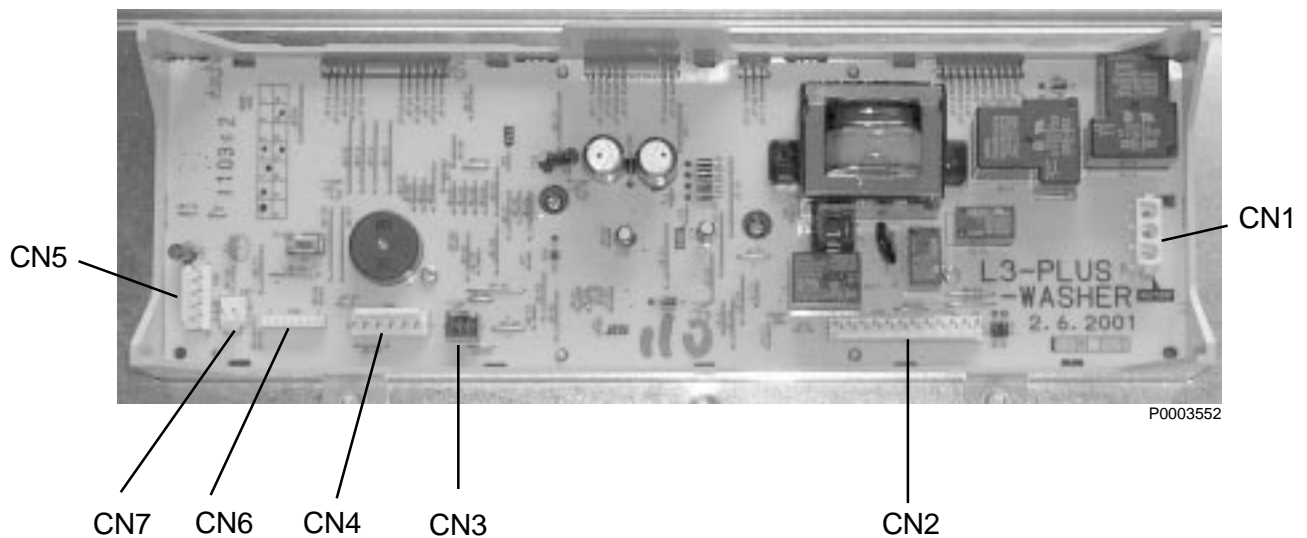

Control Filter

The potential exists for the Profile washer to cause electronic devices and systems in the vicinity to experience disruption. To eliminate the likelihood of disruption, the unit is equipped with a conductive noise filter. Should interference with electronic items be reported, suspect a problem with the filter. The ground wire attached to the bottom of the filter must have a good connection for the filter to operate properly. Check to make certain that the ground wire is connected properly before replacing the filter.



P0003582

The filter is accessed by placing the control panel in the service position.

Front Panel

The front panel is a removable, galvanized sheet metal section. The front panel is fastened at the top by 2 metal spring clips, and at the bottom by 2 metal tabs which protrude from the base of the unit into slots in the panel bottom.

Most major mechanical components can be accessed by removing the front panel.

To remove the front panel:

1. Locate 2 spring clips between the top cover and front panel by aligning a putty knife with left or right edge of lid (see illustration).
2. Insert the putty knife and push forward to release clips.
3. Rotate the front panel forward and lift off the bottom tabs.

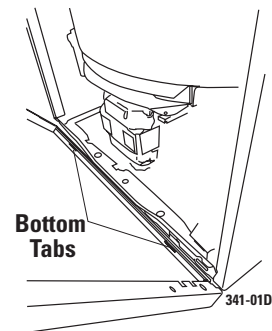
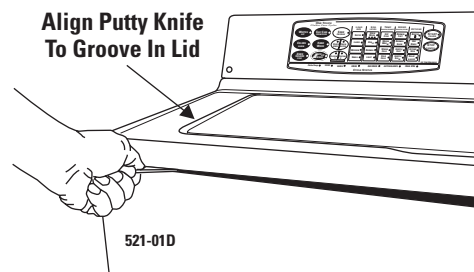

Cover/Lid Assembly

The cover/lid assembly is fastened at the front by 2 screws, on the sides by 2 metal catches, and at the back by 3 locking tabs which protrude from the bottom of the control panel.

Note: Do not allow lid to swing open when cover/lid assembly is removed. Damage may result.

To remove the cover/lid assembly:

1. Remove the front panel.
2. Remove 2 (1/4-in.) hex screws from the front of the cabinet.
3. Reach under the lid assembly and locate the lid switch. Squeeze the lid switch latch in to release it while gently pushing the switch upward. Guide lid switch through opening.
4. Pull the top cover toward you while lifting up the front edge to release the side catches and rear locking tabs. Remove the top cover.

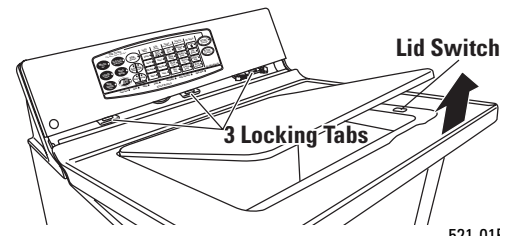
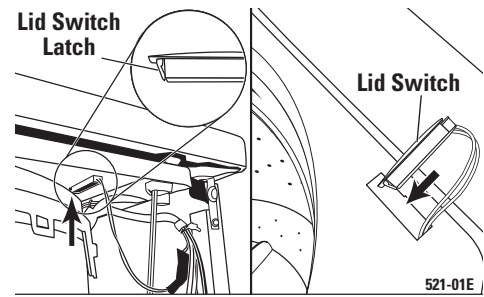

Legs

The front legs are a screw type and are adjusted by turning the legs clockwise to decrease leg extension and counterclockwise to increase leg extension.

The rear legs should be adjusted after the front of the machine is level from side to side. To adjust the rear legs, tilt the washer forward (pivot on front legs) about 4 to 6 inches. This action will set rear legs to correspond to the front settings. Gently set the washer back down.



Agitator

The agitator is a dual action, 2-piece, ratcheting type which sets on an air bell coupling. Remove the agitator by grasping the bottom and sharply pulling up.

To align the agitator for reassembly, match the grooves in the air bell to the grooves inside the agitator. The fins on the outside of the agitator are aligned with the grooves on the inside of the agitator.

To remove the air bell coupling, remove the 7/16-in. bolt and lift off the transmission shaft.

Water Valve/Automatic Temperature Control (ATC)

The water valve is a double solenoid, 120 VAC type valve with a water temperature sensor on the outlet port. Access to the water valve and water temperature sensor is obtained by removing the control panel.

The water temperature sensor is a thermistor with a negative temperature coefficient (as temperature rises, resistance lowers). Refer to the strip circuit or Schematic chapter for resistance values. The electronic control board uses the difference between the voltage sent to the water temperature sensor and voltage returning from the water



temperature sensor to determine the temperature of the incoming water and make Automatic Temperature Control (ATC) decisions.

The ATC should maintain the water temperature in the tub within the ranges specified in the Water Temperatures chart.

To prevent sudden water temperature changes on consumer's hands, the ATC does **not** function when the lid is open.

Note: During cold water fill, the hot water valve will open if the water inlet temperature is too cold.

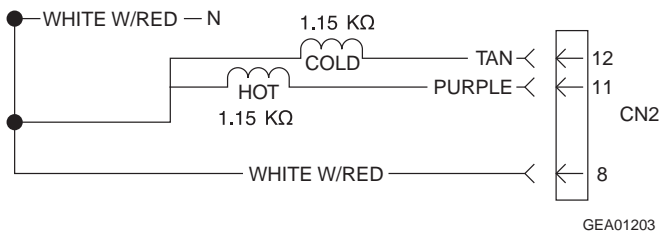

GEA01203

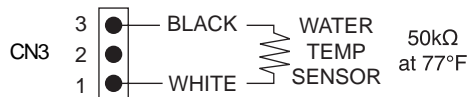

GEA00531

Water Temperatures		
Temperature Setting	Model WHSB9000B Water Temperatures	Model WPSB9080B WNSB9100B WPSB9120B Water Temperatures
Hot	115 +/- 8 °F	120 +/- 8 °F
Warm	80 +/- 7 °F	95 +/- 7 °F
Cold	Tap Water	70 +/- 7 °F

Water Level Switch

Note: Also refer to Water Level (Load Size) Diagnostic.

The water level switch has two switches in one housing and is located inside the control panel. The water level switch is connected by a hose to an air reservoir near the bottom of the outer tub. When the water level rises in the washer tub, air is trapped in the reservoir. As the water level rises, the air pressure in the reservoir increases. When 6 inches of water have accumulated in the washer tub, the appropriate pressure will be achieved and the low switch will open. The high switch will open when the water in the tub has reached its maximum level. Mid-level fills are timed, based on the amount of time it took to fill to lowest level.

Note: Before disconnecting hose from water level switch, be sure water level in machine is below bottom of wash basket. After reconnecting hose, put machine in spin for at least 1 minute before checking operation of switch.

To remove water level switch:

1. Place the control panel in service position (see procedure).
2. Using a screwdriver, gently depress the tab and turn the water level switch counterclockwise to remove it from the keyhole.

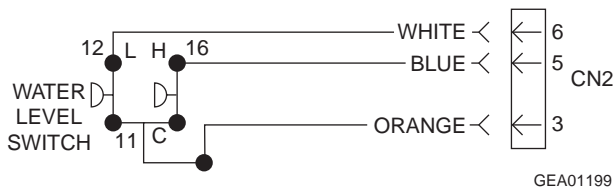

GEA01199

NOTE: The switches are normally closed (with no water in tub).

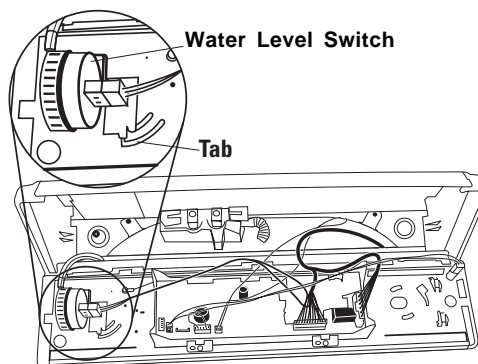

Water Level (Load Size) Diagnostic

To determine if the water level sensor and electronic control board are functioning correctly, perform the following:

1. Put the washer in Field Service Mode. Refer to the Field Service Mode and Error Codes chapter.
2. Put the washer in the function Activates Dry Agitate - 30 strokes per minute (displays AL). Refer to the Field Service Mode and Error Codes chapter.
3. Press the Start pad for 2 seconds. The motor will stop and the cold water solenoid valve will open. As the tub fills, the Load Size LEDs should illuminate. When the tub is full and the Super Load Size LED is illuminated, the washer will resume agitation.

For each load size, the water should be at the following level:

- Super - 14.0 (+/- 0.5) inches
- Large - 10.4 (+/- 0.5) inches
- Medium - 8.2 (+/- 0.5) inches
- Small - 6.1 (+/- 0.5) inches

If the **Small Load Size LED** does not illuminate when the water level reaches 6.1 (+/- 0.5) inches, check to see that the water level sensor is closed when the water level is below 6.1 (+/- 0.5) inches and that it is open when the water level is 6.1 (+/- 0.5) inches and above. If the water level sensor functions properly, replace the electronic control board.

If the **Medium or Large Load Size LED** does not operate when the water level reaches 8.2 (+/- 0.5) inches (Medium) or 10.4 (+/- 0.5) inches (Large), check to see that the Small Load Size LED operates normally (see above paragraph). If the Small Load Size LED operates normally, replace the electronic control board. **Note:** The Medium and Large Load Size water levels are timed in the electronic control board. The timing begins when the first switch of the water level sensor opens and the Small Load Size LED is illuminated.

If the **Super Load Size LED** does not illuminate when the water level reaches 14.0 (+/- 0.5) inches, check to see that the water level sensor is closed when the water level is below 14.0 (+/- 0.5) inches, and that it is open when the water level is 14.0 inches and above. If the water level sensor is functioning properly, replace the electronic control board.

Lid Switch

Note: Also refer to Lid Switch Diagnostic.

The lid switch is fastened to the cover/lid assembly by a single latch. It is a safety feature that prevents the machine from performing certain functions, such as agitate or spin, when the lid is open. The switch is closed by a magnet that is attached to the lid. When the lid is shut, the magnet will cause the switch to close, allowing normal functions to occur. When the lid is opened, the switch will return to the open position and will prevent certain washer functions.

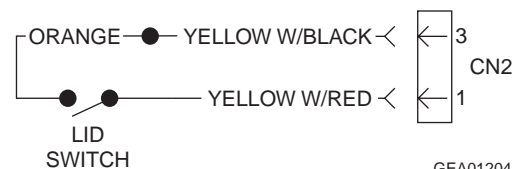
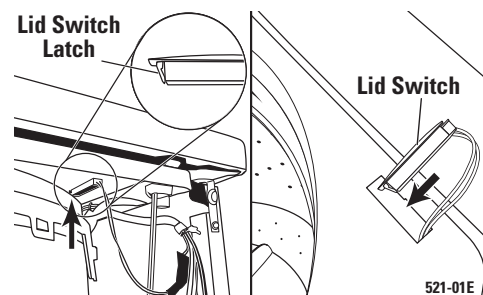

Lid Switch Diagnostic

To determine if the lid switch circuit is operating normally, enter Field Service Mode (the control panel should display Fd). This places the lid switch in the Cycle Status LED circuit. Lifting the lid should turn off all Cycle Status LEDs, which are located at the bottom of the control panel. Closing the lid should turn on all Cycle Status LEDs.

- If the Cycle Status LEDs do not turn off when the lid is open, the lid switch may be stuck closed.
- If the Cycle Status LEDs do not turn on when the lid is closed, the lid switch may be stuck open or the lid switch wiring may be open. If the lid switch and wiring are OK, the electronic control board is faulty.

Inverter

The inverter converts line-in, single phase, 60 Hz, 120 VAC, into 3-phase, varying frequency, 230 VAC. The inverter controls motor speed, torque, and direction. It also provides motor overcurrent and thermal overload protection.

Motor speed is regulated by Pulse Width Modulation (PWM). PWM outputs voltage to the motor in pulses rather than an uninterrupted flow. This pulsing produces effective voltage being received at the motor, which is equivalent to a reduction in voltage.

Motor torque is adjusted throughout the speed range by varying the pulse width modulated voltage to the motor. The inverter monitors the motor current and uses this information to calculate and make motor torque adjustments. This eliminates the requirement of a clutch.

Motor direction is changed when the inverter reverses polarity.

The inverter is mounted to the base of the washer by 2 (5/16-in.) screws and double sided tape. Access is obtained by removing the front panel.

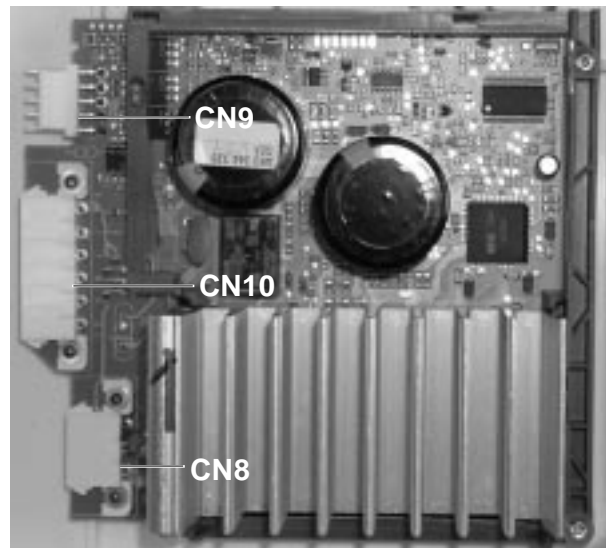

P0003555

Choke

The choke is an EMI (electromagnet interference) filter located in the lower portion of the wiring harness, close to the inverter. It is designed to reduce EMI produced by the unit. EMI has the potential to disrupt the operation of electronic devices and systems in its vicinity. Should the customer complain of interference with other electronic items while the unit is operating, check to make sure the filter (see Filter section) is properly grounded. The choke is not a replaceable part. In the event the choke fails (open), it is to be bypassed.

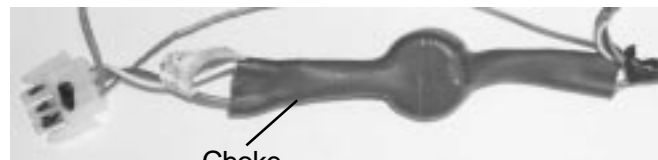

P0003571

Motor

WARNING:

- The motor is not grounded. Unplug the unit before servicing to avoid electric shock.
- Motor temperature may reach 176 °F. Use care to avoid severe burns.

Note:

- The motor is mounted on 4 ceramic insulators that insulate the motor from cabinet ground.
- The pulley has a ceramic insert to insulate the motor from cabinet ground should the belt get wet.

The drive motor is a reversing, permanent magnet, 3-phase 230 VAC motor that varies speed and torque when the pulse width modulated voltage from the inverter changes frequency or amount.

The motor has an internal tachogenerator which produces voltage when the motor shaft is rotated. This voltage is monitored by the inverter to determine motor speed. The inverter makes speed adjustments as necessary based on this information.

The inverter adjusts motor torque as necessary to start the motor; therefore, a clutch is not required. A 45-second ramp-up time can be expected at the start of agitate or spin.

Note: Terminals 1, 2, and 3 (at connector CN10) are the motor windings. Proper resistance for a cold motor is $6\ \Omega$ +/- 10% between any 2 of the 3 terminals.

To remove the motor:

1. Remove the front panel.
2. Remove 4 (3/8-in.) nuts from the bottom of the motor.
3. Move the motor toward the center to remove the belt.
4. Rotate the transmission to give the motor clearance. Tilt the top of the motor toward the transmission. Remove the motor.

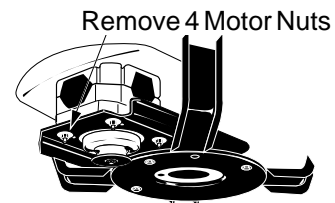

GEA01205

Note: Proper belt tension is 1/2-in. deflection at midpoint between pulleys.

Motor Tachogenerator Test

Perform the following to test the tachogenerator:

1. Disconnect harness connector CN10 from the inverter.
2. Remove the drive belt.
3. Spin the motor by hand and measure voltage between terminals 4 and 5 of the harness connector.

Note: Voltage is proportional to the motor rpm. As you spin the motor by hand, approximately 2 VAC should be produced by the tachogenerator if it is functioning properly.

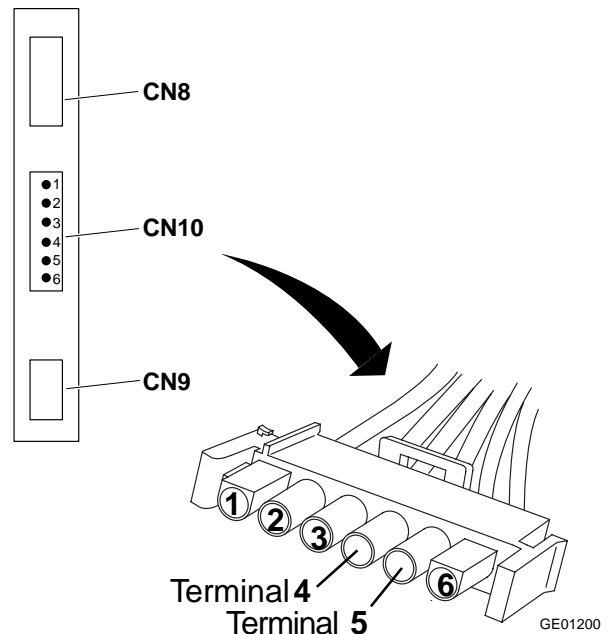

GE01200

Note: Proper tachogenerator resistance should be $190\ \Omega$ +/- 10% between terminals 4 and 5.

Drive Belt

The drive belt (P/N WH1X2026) is located under the leg and platform assembly. It extends from the motor pulley to the transmission pulley. To adjust the belt, loosen the 4 motor mounting nuts and slide the motor forward until the belt is tight, then retighten the nuts.

Note: Proper belt tension is 1/2-in. deflection at midpoint between pulleys.



P0003587

Drain Pump

Warning:

- The pump may not be grounded. Unplug the unit before servicing to avoid electric shock.
- The pump may begin operation without any advanced notice.

The drain pump is coupled to a 120 VAC, 60 Hz, 1.8 amp motor. The pump will operate independently of other mechanical components, and will evacuate water at various times during all cycles.

The pump receives L1 voltage directly from the plug and is switched on and off at the electronic control board (neutral side). When the electronic control board has closed the neutral side of the pump circuit (commanding the pump to run), the board measures the current of the pump and uses the measurements to determine if the pump is pumping water or air.



GEA00527

To remove the pump:

Note: Water will remain in hoses even when the tub appears empty. Use care to avoid water spills.

1. Lower the drain hose into a small bucket to remove any water remaining in hose.
2. Remove the front panel (see procedure).
3. Disconnect the lead wires.
4. Pinch off the black sump hose to prevent water spills.
5. Remove hose clamps and hoses from the pump.
6. Remove 2 (3/8-in.) screws and the pump.



P0003570

Suspension

The tub and motor assembly (spin basket, tub, motor, transmission, and leg and platform assembly) is suspended by four rod and spring assemblies. The rod and spring assemblies are attached to each corner of the cabinet. They extend down and connect to the leg and platform assembly. This arrangement provides limited movement to the tub and motor assembly independent of the cabinet when agitating and spinning, thus reducing cabinet travel and vibration. Front and rear suspension rod compressions vary to compensate for the added weight of the motor; therefore, they are color coded to ensure that they are replaced in the correct position (front - white, rear - black).

The tub has 4 dampening straps attached to the four corners of the cabinet. These straps prevent excessive rotation and movement during agitation, startup, and braking.

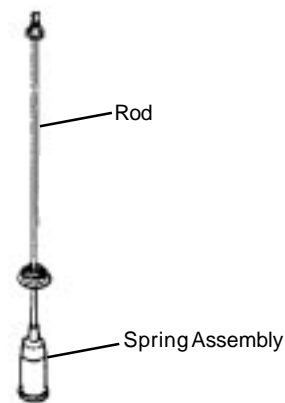

Spin Basket

The spin basket has been newly designed for Profile models. The inside perimeter of the basket has been molded with elongated protrusions extending from the top of the basket to the bottom. These protrusions produce exceptional water extraction from clothing during the spin cycle. Support bands, placed around the outer circumference of the basket, provide reinforcement and stabilization when high centrifugal force is present during high rpm spin.

To remove the basket:

1. Remove the front panel and the cover/lid assembly (see procedure).
2. Place the control panel in the service position.
3. Remove 5 hex screws from the bottom cover. Tilt the cover up and out of the way (the water valve is mounted to the cover).
4. Disconnect 4 dampening straps from the tub by removing 4 (5/16-in.) hex screws.
5. Remove the tub cover. The tub cover is attached to the tub by 8 tabs.
6. Remove the agitator by grasping the bottom and firmly pulling up.
7. Remove the 7/16-in. hex head bolt and air bell coupling from the transmission spline shaft.

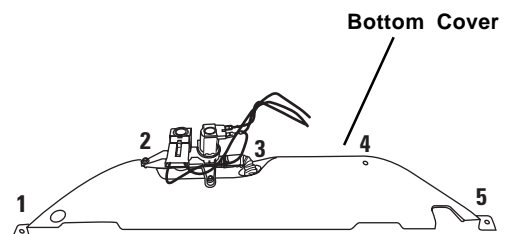

Note:

- The 1-11/16 in. nut is aluminum. Use care to avoid rounding the edges when removing or installing the nut.
 - The word “LOOSEN” and an arrow appear on the nut. Turn **clockwise** to remove.
8. Remove the left-handed 1-11/16 in. transmission hub nut.
 9. Remove the spin basket.

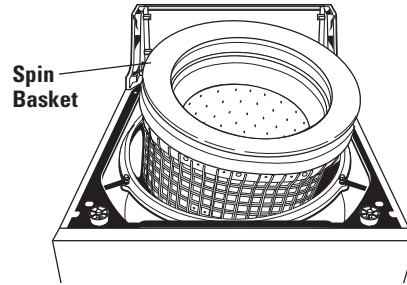
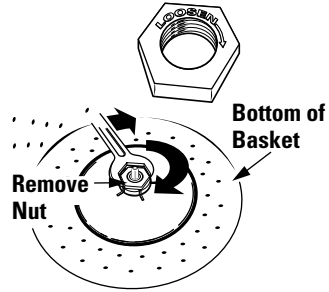

Tub With Motor and Transmission

Note: The motor can be replaced without removing the tub. Refer to the Motor section. The tub must be removed when replacing the transmission.

1. Remove the front panel, cover/lid assembly, and spin basket (see procedures).
2. Remove the split ring and washer from the transmission.
3. Disconnect the motor harness connector, grounding wire to the frame, and water pressure sensor hose.
4. Pinch off the drain sump hose to prevent water spills.
5. Disconnect the drain sump hose (black hose) at the tub.

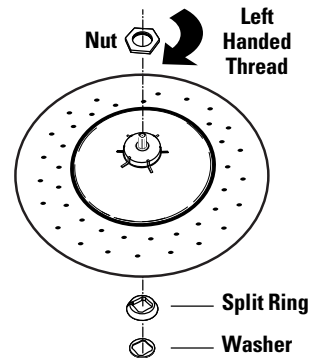

Note: The front and rear rod and spring assemblies have different spring compressions and should not be interchanged (front - white, rear - black).

6. Disengage the rear rod and spring assemblies (one at a time) by raising the rear of the tub (this can be done by rocking the top of the tub toward you) and removing the spring assemblies from the leg and platform assembly.
7. Disengage the front rod and spring assemblies by raising the tub and removing the spring assemblies from the leg and platform assembly.

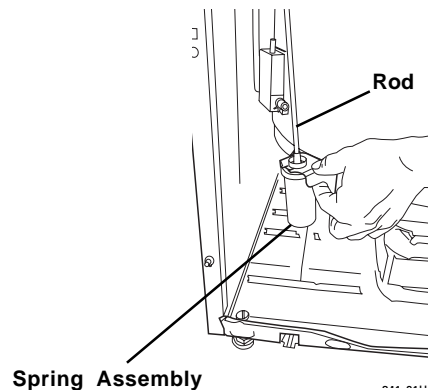

8. Lift and push the bottom of the tub assembly toward the rear of the cabinet, then roll the top of the tub assembly out from under the top lip of cabinet.
9. Pull out the tub by lifting it over on its top.

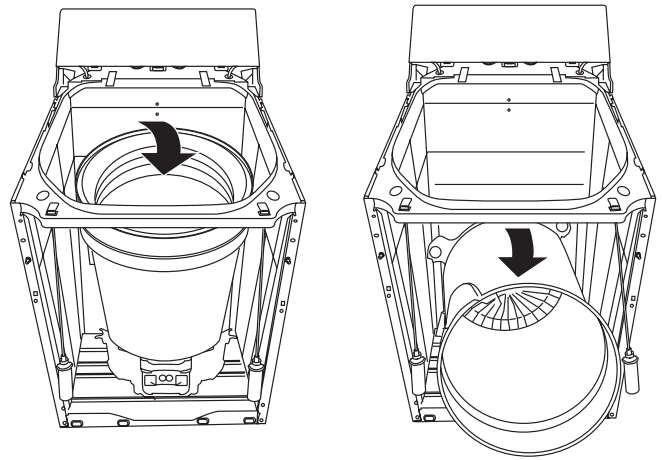

Transmission

Note: The tub must be removed when replacing the transmission.

1. Remove the tub with the motor and transmission (see procedure).
2. Remove the transmission drive pulley by holding the belt as shown and removing the 3/4-in. pulley nut.

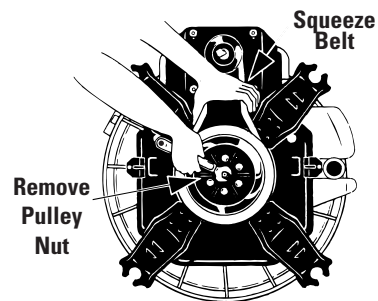

3. Remove 4 (3/8-in.) bolts mounting the transmission to the leg and platform assembly.

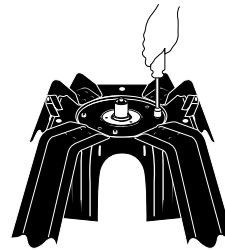

4. Remove 4 (1/2-in.) hex bolts and leg and platform assembly from the tub.

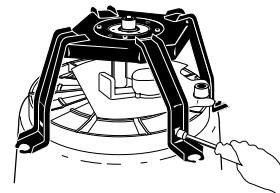

5. Lift transmission up and out of the tub.

Note: The transmission and brake are one assembly and are replaced as a single component.

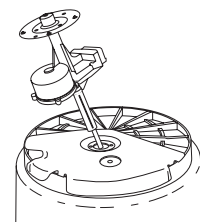

Schematic

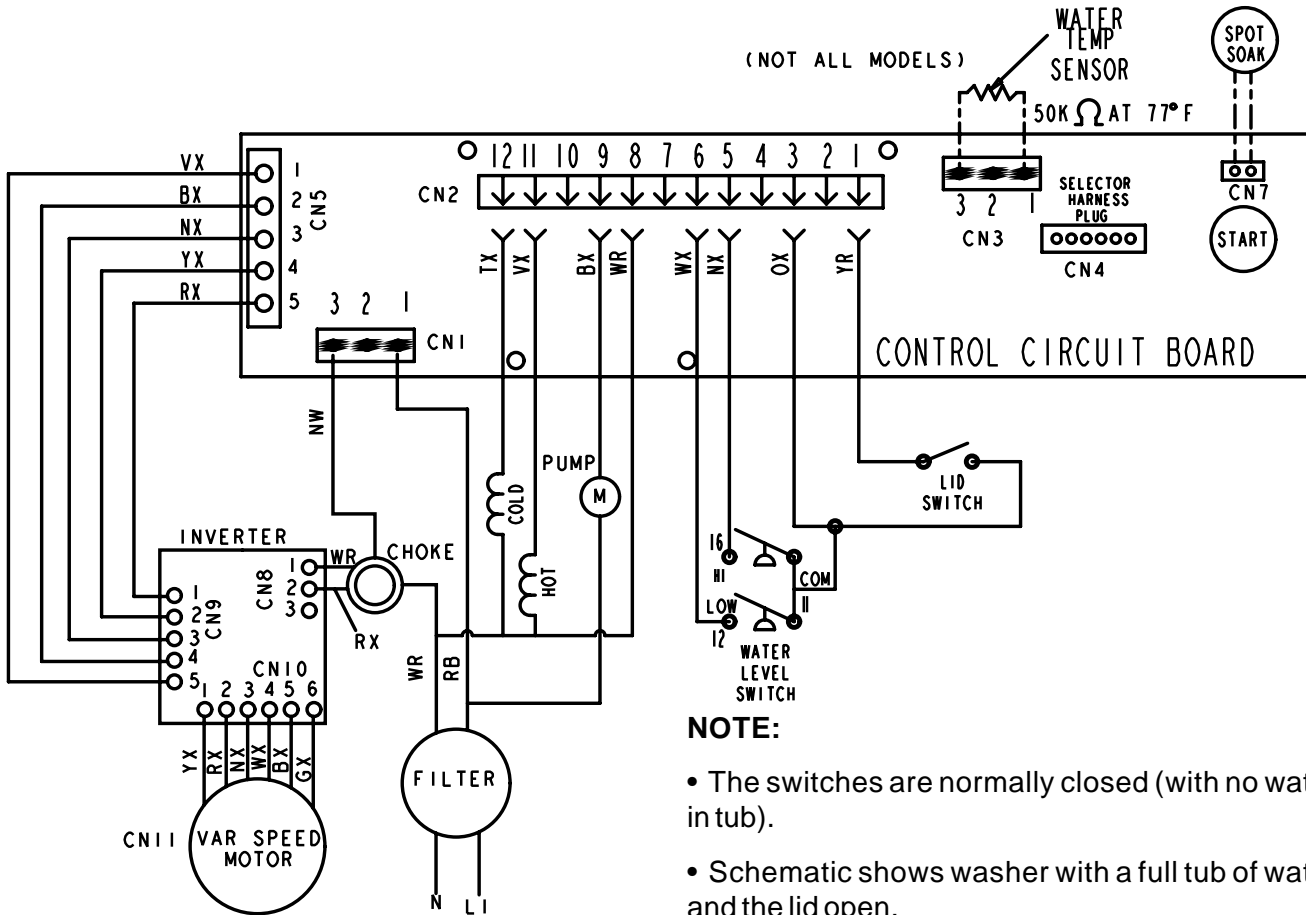

CONN.	INPUT/OUTPUT	COMPONENT
CN1-1	L1 Input	House Supply via Filter
CN1-3	Neutral	House Supply via Choke and Filter
CN2-1	15 VDC Input	Lid Switch
CN2-3	15 VDC Output	Lid Switch, Water Level Sensor
CN2-5	15 VDC Input	Water Level Sensor (Hi)
CN2-6	15 VDC Input	Water Level Sensor (Low)
CN2-8	Neutral	House Supply via Filter
CN2-9	Neutral (switched)	Drain Pump
CN2-11	L1 Output (switched)	Hot Water Valve
CN2-12	L1 Output (switched)	Cold Water Valve
CN3-1	5 VDC Output*	Water Temperature Sensor
CN3-3	Input	Water Temperature Sensor
CN5-1	Communication	Inverter
CN5-2	Communication	Inverter
CN5-3	Communication	Inverter
CN5-4	Communication	Inverter
CN5-5	Communication	Inverter
CN7-1	5 VDC Output	Spot Soak Switch
CN7-2	5 VDC Input	Spot Soak Switch

* Measured with water temperature sensor disconnected. Black test lead connected to CN3-3.

Field Service Mode and Error Codes

Field Service Mode

Field Service Mode enables individual machine functions to be selected and performed apart from the unit's normal operation. Field Service Mode also allows error codes to be displayed.

Field Service Mode is **entered** by simultaneously pressing and holding the Whites/Hot (Whites/Fast) and the Start pads for 3 seconds. When Field Service Mode is entered, the control panel displays the letters Fd (Field Service Diagnostics).

Enter Field Service Mode

Exit Field Service Mode

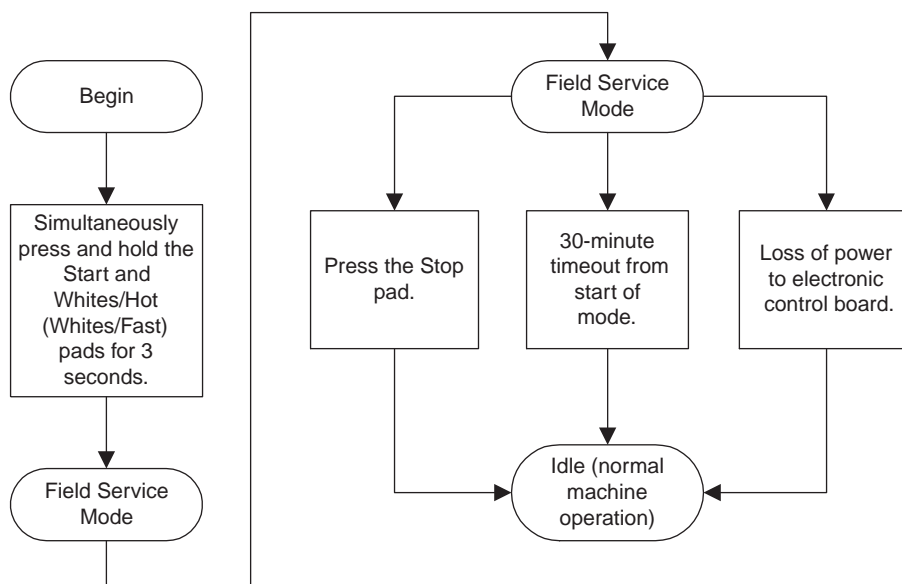

Field Service Mode can be **exited** in three ways:

1. Press the Stop pad.
2. Unplug the unit.
3. Electronic control board automatically exits Field Service Mode after 30 minutes.

To **index to the next function** within Field Service Mode, press the Colors/Warm (Colors/Fast) pad. To **index back to the previous function**, press the Whites/Hot (Whites/Fast) pad. The following table describes the Field Service Mode functions:

Field Service Mode Functions	
Display	Function
Fd	LED check
**	model code
E#	error code
H	opens hot valve
C	opens cold valve
AL	activates dry agitate - 105 strokes per minute
AH	activates dry agitate - 155 strokes per minute
P	activates pump
SP	activates high speed spin - 630 rpm

** Represents the model code.

Represents the number of the error code.

Error Codes

Refer to the steps below to check error codes. Refer to the Error Codes table for a listing and description of all error codes.

To check error codes:

1. Enter Field Service Mode.
2. Index to the Error Codes function using the Colors/Warm (Colors/Fast) pad.
 - If no errors are present, the control panel display will be blank.
 - If an error code is present, the error code will display immediately. If there is more than one error, each error code will display for 2 seconds followed by the next error code.

To clear all error codes, press the Start pad while in the Error Codes function.

Error Codes			
Display	Function/Error	Problem	Solution
E1	EEPROM error	EEPROM faulty	Replace electronic control board.
E2	Water Temperature Sensor error	Water temperature sensor or connection	Check water temperature sensor and connections. Refer to the Water Valve/Automatic Temperature Control section. Replace or repair as needed.
E4	Slow Pump error	Pumped more than 3 minutes	Check for clog and stand pipe height.
E5	No/Slow Fill error	Electronic control board has been attempting to fill for 20 to 40 minutes	Check water inlets, fill hoses, faucets, machine water valve (solenoid valves), and water valve wiring.
E6	No Pump error	No power to pump detected	Check pump and harness connections.
E7	Push Button error	Pad shorted	Remove any objects that may press pads. If, after codes are cleared, error code E7 is set again, replace electronic control board.
E8	Pressure Switch error	High level pressure switch opens before low level pressure switch	Check pressure switch and hose. Replace or repair as needed.

EEPROM Error (E1)

When the data is incorrectly stored, or won't write correctly from read-only memory to the EEPROM, the E1 error is set.

Thermistor Error (E2)

The electronic control board checks the water temperature sensor. If the sensor is open or shorted, the electronic control board completes the wash cycle and sets the E2 error.

Slow Pump Error (E4)

If the pump-sensing circuit in the electronic control board does not detect that the water has been pumped from the washer within 3 minutes, the E4 error is set.

Fill Error (E5)

If the electronic control board is attempting to fill the tub and does not see the low-level switch open within 20 minutes, or does not see the high-level switch open within 40 minutes, the E5 error is set.

No Pump Error (E6)

If the pump-sensing circuit detects that water is not being pumped when the pump is energized, and the pressure switch indicates that water is present in the tub, the E6 error is set.

Push Button Error (E7)

If any pad is closed for 1 minute or longer, the E7 error is set.

Pressure Switch Error (E8)

If the high level pressure switch opens before the low level pressure switch opens, or if the low level pressure switch closes before the high level pressure switch closes, the E8 error is set.

Motor Does Not Operate Diagnostic

Note: Before performing this diagnostic, check for the following:

- Transmission locked
- Loose or missing belt

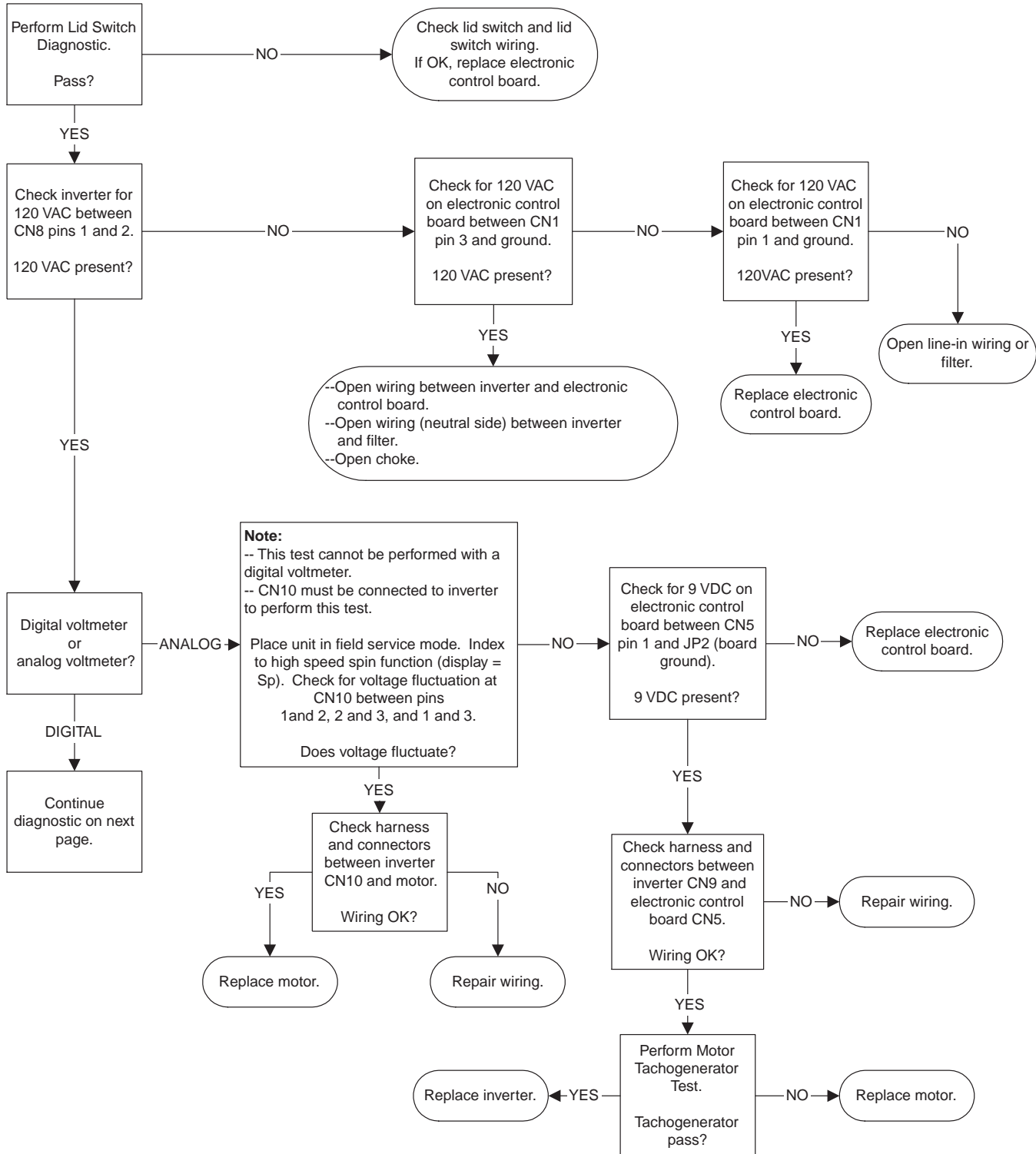

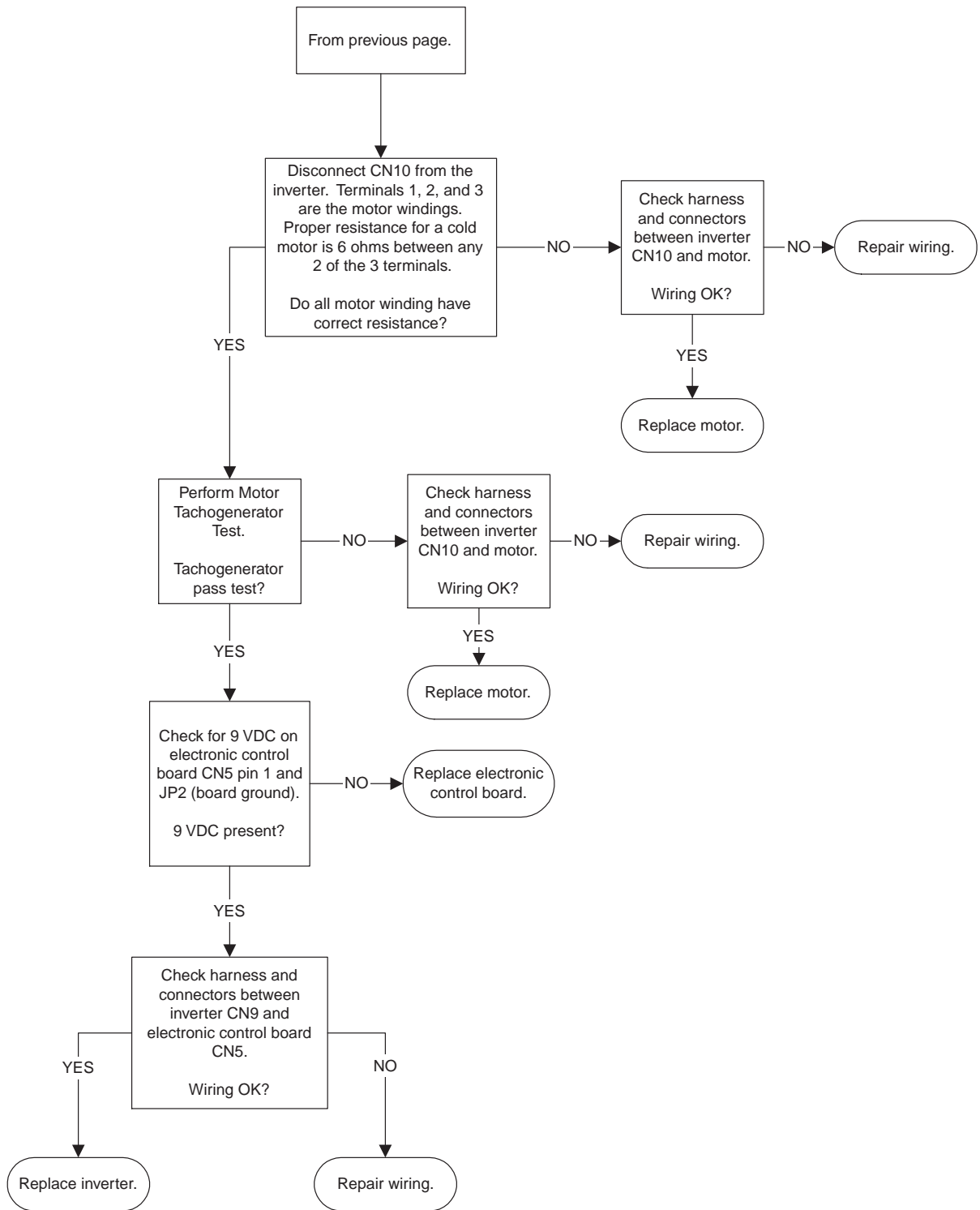

Problem Chart

Error Reported	Possible Problem	Probable Cause and Action
Leak reported.	Unit has a leak that cannot be found.	Tub cover/floodhead bad. Replace if necessary.
Leak reported.	Soap suds overflowing the tub cover.	The user added too much detergent to the washer. Use less detergent.
The washer is making a clicking sound.	Faulty lid switch.	Faulty lid switch or lid switch wiring. Refer to Lid Switch Diagnostic.
The washer is making a clicking sound.	Low voltage at plug.	Too many devices plugged into the same outlet, or an extension cord is being used to operate the machine. Use an individual circuit.
The washer is making a clicking sound.	Faulty pressure switch connection.	Bad connection at pressure switch or 12 pin connector. Reconnect/retighten connection.
Washer is not spinning.	Faulty lid switch.	Faulty lid switch or lid switch wiring. Refer to Lid Switch Diagnostic.
Washer is not spinning.	Faulty pressure switch connection.	Bad connection at pressure switch or 12 pin connector. Reconnect/retighten connection.
Washer is not spinning.	Blocked pressure hose. Faulty pressure switch.	Pressure switch will not reset. Check pressure hose for blockage. If OK, replace pressure switch.
Washer is not spinning.	Bad motor or inverter.	See Motor Does Not Operate Diagnostic flowchart.
Washer is not agitating.	Faulty lid switch.	Faulty lid switch or lid switch wiring. Refer to Lid Switch Diagnostic.
Washer is not agitating.	Faulty pressure switch connection.	Bad connection at pressure switch or 12 pin connector. Reconnect/retighten connection.
Washer is not agitating.	Blocked pressure hose. Faulty pressure switch.	Pressure switch will not reset. Check pressure hose for blockage. If OK, replace pressure switch.
Washer is not agitating.	Bad motor or inverter.	See Motor Does Not Operate Diagnostic flowchart.
Control not responding.	Control locked up and cannot be accessed.	Noise spike on 120 VAC circuit. Unplug for 20 seconds to reset control and recheck.
Control not responding.	Damaged board.	Possible lightning strike causing damage to board. Inspect board for burn/scorch, replace if damage found.
Machine slows down during agitation.	Customer unaware of product features.	Machine has 105 strokes/minute slow agitate at the end of some cycles. Normal operation.
Machine starts spin in slow speed, then switches to high.	Customer unaware of product features.	Machine starts spin in slow speed, then switches to the customer-selected speed. Normal operation.

Troubleshooting Guide

PERFECTEMP PLUS	Possible Causes	What To Do
PerfectTemp Plus wash temperature is incorrect <i>(Review PerfectTemp Plus in the About washer features section)</i>	The washer is in a cold rinse cycle	<ul style="list-style-type: none"> This is normal. The PerfectTemp Plus feature is designed not to activate during a cold rinse cycle to improve the energy efficiency of your washer.
	All the water in the household water heater has been used	<ul style="list-style-type: none"> Wait until the water in the water heater is heated to the correct temperature.
PERFORMANCE	Possible Causes	What To Do
Clothes too wet	Incorrect spin speed selected	<ul style="list-style-type: none"> Make sure the spin cycle selected matches the load you are washing. Some fabrics will feel wetter when rinsed with cold water.
	Colored spots	<ul style="list-style-type: none"> Check fabric softener package for instructions and follow directions for using dispenser. Pretreat stain and rewash.
Grayed or yellowed clothes	Dye transfer	<ul style="list-style-type: none"> Sort whites or lightly colored items from dark colors.
	Not enough detergent	<ul style="list-style-type: none"> Use more detergent (especially with larger loads). Be sure to follow detergent manufacturer's directions.
	Hard water	<ul style="list-style-type: none"> Use a water conditioner like Calgon brand or install a water softener.
	Water is not hot enough	<ul style="list-style-type: none"> Make sure water heater is delivering water at 120°F–140°F (48°C–60°C).
	Washer is overloaded	<ul style="list-style-type: none"> Select load size to match clothes load.
	Detergent is not dissolving	<ul style="list-style-type: none"> Add detergent as wash basket fills with water before you load clothes.
Lint or residue on clothes	Dye transfer	<ul style="list-style-type: none"> Sort clothes by color. If fabric label states <i>wash separately</i>, unstable dyes may be indicated.
	Clothes are air or line dried	<ul style="list-style-type: none"> If you do not dry your clothes with a clothes dryer, your clothes may retain more lint.
	Incorrect sorting	<ul style="list-style-type: none"> Separate lint producers from lint collectors.
	Washing too long	<ul style="list-style-type: none"> Wash small loads for a shorter time than larger loads.
	Detergent not dissolving	<ul style="list-style-type: none"> Add detergent as wash basket fills with water, before you load clothes. Try a liquid detergent. Use warmer water temperature.
		Overloading
	Incorrect use of fabric softener	<ul style="list-style-type: none"> Check fabric softener package for instructions and follow directions for using dispenser.

PERFORMANCE (cont.)	Possible Causes	What To Do
Pilling	Result of normal wear on poly-cotton blends and fuzzy fabrics	<ul style="list-style-type: none"> • While this is not caused by the washer, you can slow the pilling process by washing garments inside out.
Snags, holes, tears, rips or excessive wear	Pins, snaps, hooks, sharp buttons, belt buckles, zippers and sharp objects left in pockets	<ul style="list-style-type: none"> • Fasten snaps, hooks, buttons and zippers. • Remove loose items like pins, objects in pockets and sharp buttons. • Turn knits (which snag easily) inside out.
	Undiluted chlorine bleach	<ul style="list-style-type: none"> • Check bleach package instructions for proper amount. • Never add undiluted bleach to wash or allow clothes to come in contact with undiluted bleach.
	Chemicals like hair bleach or dye, permanent wave solution	<ul style="list-style-type: none"> • Rinse items that may have chemicals on them before washing.
Wrinkling	Improper sorting	<ul style="list-style-type: none"> • Avoid mixing heavy items (like work clothes) with light items (like blouses). • Try a fabric softener.
	Overloading or incorrect water level	<ul style="list-style-type: none"> • Load your washer so clothes have enough room to move freely.
	Incorrect wash and dry cycles	<ul style="list-style-type: none"> • Match Cycle selection to the type of fabric you are washing (especially for easy care loads).
	Repeated washing in water that is too hot	<ul style="list-style-type: none"> • Wash in warm or cold water.

OPERATION	Possible Causes	What To Do
Washer pauses in cycle	The HAND WASH or CASUALS cycle was chosen	<ul style="list-style-type: none"> • This is normal. The washer alternates between agitate and soak during the HAND WASH and CASUALS cycles to get your clothes cleaner with less water.
Washer won't operate	Washer is unplugged	<ul style="list-style-type: none"> • Make sure cord is plugged securely into a working outlet.
	Water supply is turned off	<ul style="list-style-type: none"> • Turn both hot and cold faucets fully on.
	Controls are not set properly	<ul style="list-style-type: none"> • Check controls.
	Lid is open—safety feature prevents agitation and spinning when lid is up.	<ul style="list-style-type: none"> • Close lid and reset cycle, to the beginning if necessary.
	Circuit breaker/fuse is tripped/blown	<ul style="list-style-type: none"> • Check house circuit breakers/fuses. Replace fuses or reset breaker. Washer should have separate outlet.
	Electronics need to be reset	<ul style="list-style-type: none"> • Unplug washer, wait 2 minutes, plug back in, and press START.
	START was not pressed	<ul style="list-style-type: none"> • Press START.
Extremely low water pressure	<ul style="list-style-type: none"> • Press START again. 	

WATER	Possible Causes	What To Do
Too many suds	Type of detergent	<ul style="list-style-type: none"> • Switch to a lower sudsing detergent brand and follow instructions on package.
	Very soft water	<ul style="list-style-type: none"> • Try less detergent.
	Too much detergent	<ul style="list-style-type: none"> • Measure your detergent carefully. Use less soap if you have soft water, a smaller load or a lightly soiled load.
Water leaks	Fill hoses or drain hose is improperly connected	<ul style="list-style-type: none"> • Make sure hose connections are tight at faucets and at washer. • Make sure end of drain hose is properly connected to washer and correctly inserted in and secured to drain facility.
	Household drain may be clogged	<ul style="list-style-type: none"> • Check household plumbing. You may need to call a plumber.
	Constant water pressure to the fill hoses at the water source	<ul style="list-style-type: none"> • Tighten hoses at the faucets and turn the water off after each use. • Check condition of the fill hoses; they should be replaced every 5 years.
	Using too much detergent in washer	<ul style="list-style-type: none"> • Use less detergent. Use less soap if you have soft water, a smaller load or a lightly soiled load.
Water temperature is incorrect	Control is not set properly	<ul style="list-style-type: none"> • Check water temperature control and adjust.
	Water supply is turned off or improperly connected	<ul style="list-style-type: none"> • Turn both hot and cold faucets fully on and make sure hoses are connected to correct faucets.
	Water valve screens are stopped up	<ul style="list-style-type: none"> • Turn off the water source and disconnect water fill hoses from the upper back of the washer. Use a brush or toothpick to clean the screens in the machine. Reconnect the hoses and turn the water back on.
	House water heater is not set properly	<ul style="list-style-type: none"> • Make sure house water heater is delivering water at 120°F–140°F (48°C–60°C).
	PerfectTemp Plus feature was not activated	<ul style="list-style-type: none"> • The lid must be closed for PerfectTemp Plus to work.
Water pumped out before cycle is complete	Lid lifted or cycle was put in pause for over 24 hours	<ul style="list-style-type: none"> • Reset cycle.
Water won't drain	Drain hose is kinked or improperly connected	<ul style="list-style-type: none"> • Straighten drain hose and make sure washer is not sitting on it. • Top of drain outlet should be less than 8 ft (2.5 m) above floor.
Water spraying during spin cycle	Washer in spin cycle	<ul style="list-style-type: none"> • Spray rinse during a spin cycle is normal.
Washer did not fill to chosen level (PerfectTemp Plus and START lights are flashing)	Extremely low water pressure	<ul style="list-style-type: none"> • Press the START button again.
	Inlet hoses are kinked	<ul style="list-style-type: none"> • Straighten hoses.
	Water valve screens are stopped up	<ul style="list-style-type: none"> • Turn off the water source and disconnect water fill hoses from the upper back of the washer. Use a brush or toothpick to clean the screens in the machine. Reconnect the hoses and turn the water back on.
Water fills and drains at the same time	Drain stand pipe is too low	<ul style="list-style-type: none"> • Drain stand pipe must be above 30" (76.2 cm).

NOISE	Possible Causes	What To Do
Washer is noisy	Washer is uneven	<ul style="list-style-type: none"> To level the front of the washer, adjust the front leveling legs by rotating the individual leg in the proper direction for up or down. To level back of washer, lift back of machine 4" (11 cm) and set down.
	Washer load is unbalanced	<ul style="list-style-type: none"> Press START to pause the washer, open the lid and redistribute the load evenly. Close the lid and press START again.
	Shipping rod is still assembled in unit	<ul style="list-style-type: none"> To remove shipping rod from washer, pull yellow tag and attached rod from the bottom right hand side of washer.
	Washer is sitting too close to wall (causes knocking during cycle)	<ul style="list-style-type: none"> Pull washer away from the wall; about 4" (11 cm) is needed.
	PerfectTemp Plus feature is being used	<ul style="list-style-type: none"> This is normal. PerfectTemp Plus turns water valves off and on to adjust water temperature.
OTHER	Possible Causes	What To Do
Labels on the exterior of the washer will not peel off cleanly	Occasionally the adhesive used on the labels does not release cleanly	<ul style="list-style-type: none"> Use a hair dryer set at the lowest heat setting, directing the air at the label for a short amount of time. This will release the adhesive easily, without damaging the surface of the washer.

Review

1. The drive motor is:

- a) 120 VAC
- b) 230 VAC
- c) 230 VDC
- d) 351 CID

2. The inverter controls:

- a) Drive motor speed.
- b) Drive motor torque.
- c) Drive motor direction.
- d) All of the above.
- e) None of the above

3. The drive motor is protected against thermal overload by:

- a) An internal overload switch
- b) An external overload switch.
- c) The mercury switch.
- d) The inverter.

4. If the choke fails, proper repair procedure is:

- a) Replace the choke and wiring harness.
- b) Replace only the choke.
- c) Bypass the choke.
- d) Replace the inverter.

5. If the control filter fails, the result will be:

- a) Dirty wash and rinse water.
- b) Electrical components and systems in the vicinity may experience disruption.
- c) Electrical components and systems in the vicinity may disrupt washer operation.
- d) Drive motor output will be diminished.

6. Motor speed is adjusted by:

- a) The inverter adjusting tachogenerator output.
- b) The inverter varying the frequency of electrical pulses to the drive motor.
- c) The choke restricting the voltage to the drive motor.
- d) None of the above.

7. To enter Field Service Mode:

- a) Press and hold the Start and Stop pads for 3 seconds.
- b) Press and hold the Start and Whites/Hot (Whites/Fast) pads for 3 seconds.
- c) Place the control panel in the service position and trip the Field Service Mode switch.
- d) Plug the power cord into the Field Service Mode receptacle.

8. Drive motor torque is adjusted by the:

- a) 2 speed clutch
- b) Torque converter
- c) Inverter
- d) Torque spring

9. To test the tachogenerator:

- a) Spin the drive motor shaft by hand while checking for voltage at CN 10 between pins 4 and 5.
- b) Use a standard auto timing light.
- c) Spin the drive motor shaft and check for voltage at CN 10 between pins 1 and 2.
- d) Feel for tingle with finger at inverter CN 10 pins 3 and 4.

10. Normal drive motor ramp up time will be:

- a) Up to 45 seconds.
- b) Up to 90 seconds.
- c) Less than 10 seconds
- d) 0 to 60 in 5 seconds.

Warranty

GE Washer Warranty



All warranty service provided by our Factory Service Centers, or an authorized Customer Care[®] technician. To schedule service, on-line, 24 hours a day, visit us at GEAppliances.com, or call 800.GE.CARES (800.432.2737).

Staple your receipt here.
Proof of the original purchase date is needed to obtain service under the warranty.

For The Period Of: We Will Replace:

One Year
From the date of the original purchase

Any part of the washer which fails due to a defect in materials or workmanship. During this **full one-year warranty**, GE will also provide, **free of charge**, all labor and in-home service to replace the defective part.

Two Years
From the date of the original purchase

Any part of the washer which fails due to a defect in materials or workmanship. During this **additional one-year limited warranty**, you will be responsible for any labor or in-home service costs.

Five Years
From the date of the original purchase

The suspension rod and spring assembly and electronics, if any of these parts should fail due to a defect in materials or workmanship. GE will also replace the **washer lid or cover**, if they should rust under operating conditions. During this **additional four-year limited warranty**, you will be responsible for any labor or in-home service costs.

Ten Years
From the date of the original purchase

The transmission and outer washer tub, if any of these parts should fail due to a defect in materials or workmanship. During this **additional nine-year limited warranty**, you will be responsible for any labor or in-home service costs.

Lifetime
From the date of the original purchase

The washer basket, if it should fail due to a defect in materials or workmanship. During this **lifetime limited warranty**, you will be responsible for any labor or in-home service costs.

What Is Not Covered:

- Service trips to your home to teach you how to use the product.
- Improper installation.
- Failure of the product if it is abused, misused, or used for other than the intended purpose or used commercially.
- Replacement of house fuses or resetting of circuit breakers.
- Damage to the product caused by accident, fire, floods or acts of God.
- Incidental or consequential damage caused by possible defects with this appliance.

This warranty is extended to the original purchaser and any succeeding owner for products purchased for home use within the USA. In Alaska, the warranty excludes the cost of shipping or service calls to your home.

Some states do not allow the exclusion or limitation of incidental or consequential damages. This warranty gives you specific legal rights, and you may also have other rights which vary from state to state. To know what your legal rights are, consult your local or state consumer affairs office or your state's Attorney General.

Warrantor: General Electric Company, Louisville, KY 40225