



WASHING MACHINE SERVICE MANUAL

⚠ CAUTION

READ THIS MANUAL CAREFULLY TO DIAGNOSE
PROBLEMS CORRECTLY BEFORE SERVICING THE UNIT.

MODEL : 796.3152#21#

SAFETY PRECAUTION!

IMPORTANT SAFETY NOTICE!

This service information is intended for individuals possessing adequate backgrounds of electrical, electronic, and mechanical experience. Any attempt to repair this appliance may result in personal injury or property damage. The manufacturer or seller can not be responsible for the interpretation of this information, nor can it assume any liability in connection with its use.

⚠ WARNING: To reduce the risk of fire, electric shock, or personal injury when using this appliance, follow basic precautions, including the following:

- **Wear gloves when working.**
Failure to do this can result in serious injury.
- **The appliance is heavy. Two or more people is required when moving the appliance.**
There is a risk of serious back injury or other injuries.
- **Certain internal parts are intentionally not grounded and may present a risk of electric shock only during servicing. Service personnel - Do not contact the following parts while the appliance is energized.**
: Pump bracket, rotor and heater
- **Disconnect this appliance from the power supply before servicing. Turning the controls to the off position does not disconnect this appliance from the power supply.**
Failure to do this can result in shock.
- **Reconnect all grounded devices after servicing.**
Failure to do this can result in shock.

To reduce the risk of fire, electric shock, or personal injury when using this appliance, follow basic precautions, including the following.

CONTENTS

1. Specifications	3
2. Installation Instructions	
2-1. How to Adjust Level	4
2-2. Connecting Water Supply Hose	6
2-3. Connect the Drain Hose	7
3. Operating Instructions	
3-1. Identification of Parts	8
3-2. Before Starting to Wash	9
3-3. Function of Each Button	16
3-4. Washing Programs	18
3-5. Care and Maintenance	20
4. Service Information	
4-1. Wiring Diagram	21
4-2. Disassembly Instruction	22
4-3. Test Running Without Water	29
4-4. Troubleshooting By Common Washing Problems	30
4-5. Troubleshooting Summary	31
4-6. Troubleshooting with Error Code	32
4-7. Other Troubleshooting	37
5. Component Testing Information.....	39
5-1. Filter Assembly (Line Filter)	39
5-2. Door Lock Switch Assembly.....	40
5-3. Stator Assembly	42
5-4. Pump Motor Assembly	45
5-5. Inlet Valve Assembly	46
5-6. Heater Assembly	47
5-7. Thermistor Assembly.....	48
6. Exploded View	50
7. Replacement Part List	54

1. SPECIFICATIONS

Model	3152#21#
Electrical	120VAC@60Hz.
Inner Tub	Stainless
Inlet Water Pressure	14.5 ~ 116 PSI (100 ~ 800 kPa)
Rating of Fuse	120V/60Hz
Spin Speed	1100 ±50
Weight	145.5 lbs (66kg)
Cycles	Normal/Casual, Cold Clean, Heavy Duty, Bulky/Bedding, Whitest Whites, Rinse&Spin, Kids Wear, Towels, Workout Wear, Colors, Express Wash, Handwash/Wool, Delicates, Sanitize
Time Delay	1-19Hr
Lid Interlock Switch	Magnet Sensor
Control Lock	Yes
Softener Dispenser	Yes
Detergent Dispenser	Yes
Bleach Inlet	Yes
Auto Power Off	Yes
Smart Rinse™ with Jet Spray	Yes
Heater	Yes

2. INSTALLATION INSTRUCTIONS

2-1. HOW TO ADJUST LEVEL

1

Installation area

- Install the washer on a firm, flat surface.
- If the washer is installed on an unsuitable floor, it could make considerable noise and vibrate.

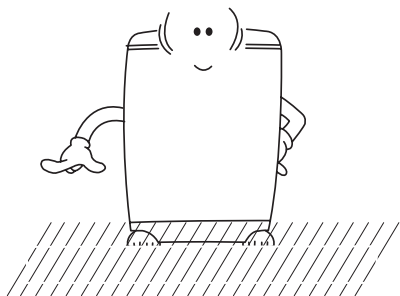

3

Checking level

- Open the lid, check if the washer is correctly leveled by looking down from the top. If a gap is seen between the tub and drum, the washer is not level.

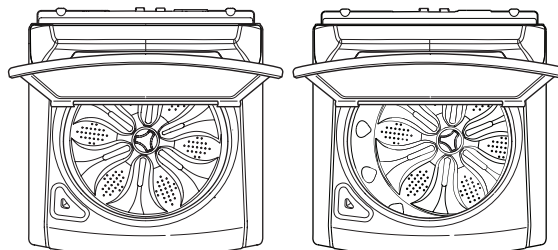

Right

Wrong

2

Set Leveling feet

- Adjust the leveling feet, Turn clockwise to raise the washer or counterclockwise to lower it.

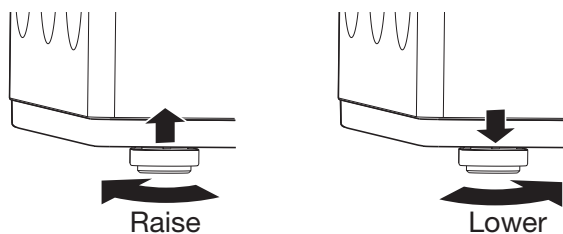

4

Checking slope

- If installation surface is tilted, the washer will vibrate. Do not install on a sloping floor.

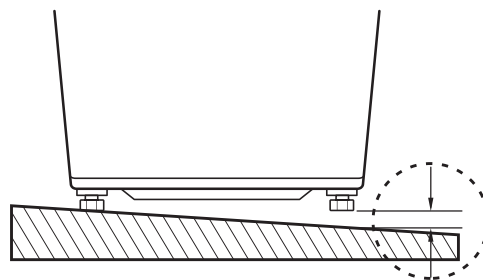

No shims. It would be dangerous. If the floor is that far from being level, it is a floor problem and not a washer problem.

⚠ CAUTION

- The ventilating openings in the base area must not be obstructed by carpeting.
- Install the washing machine on a level and firm surface, and tilt should be less than 1°
- Wooden floors may need reinforcing to prevent the normal vibration which occurs with an unbalanced load.
- Do not install the washer on an inclined floor.
Improper installation of the washer may cause noise and malfunctioning.

5

Horizontal setting

- If the washer is not level, adjust the leveling feet. Turn clockwise to raise, counterclockwise to lower.

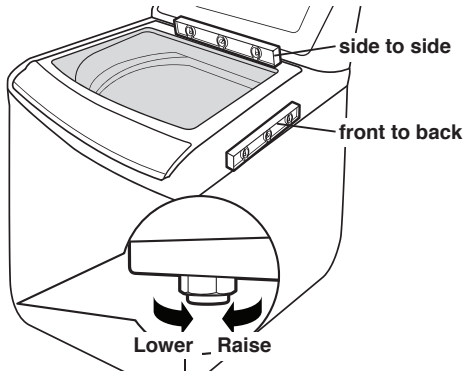

6

Confirming level

- Place the washer in original position, confirming the level.

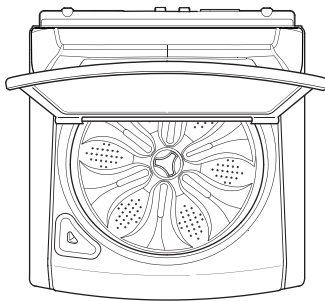

7

Distance between the drain hose and the wall

- Distance between the drain hose and the wall should be more than 4 inches (10 cm), and the distance between any other part and the wall should be more than 1 inches (2.5 cm)

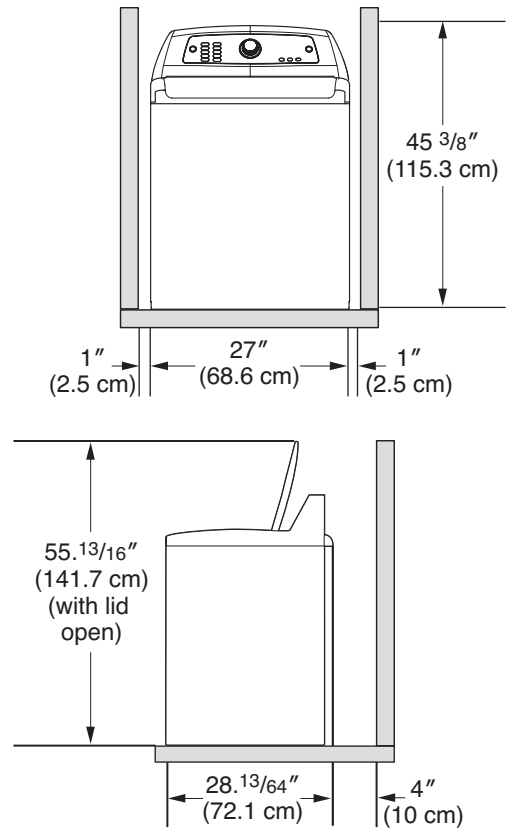

Do not install the washer in the following places.

- Where the washer is exposed to direct sunlight.
- Near a heater or heating appliance.
- Where the washer is exposed to freezing temperatures.
- In damp environments such as bathrooms or harmful environments.

2-2. CONNECTING WATER SUPPLY HOSE

Before connecting the Water Supply Hose to the water tap, check the hose type and then choose the correct instruction here under.

Screw Type

1 Attach the water supply hose to the tap.

Push the water supply hose up so that the rubber packing within the hose can adhere completely to the tap.

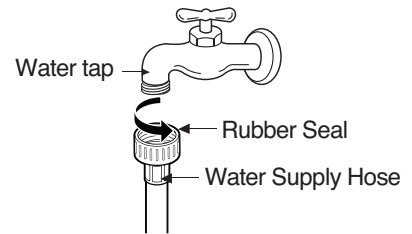

2 Connect the water supply hose to the tap.

Connect the water supply hose to the tap and then tighten it by screwing it to the right.

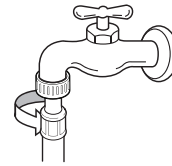

3 Check water leakage.

After connecting the hose, open the tap to check for any water leakage.

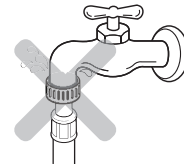

Connecting Water Supply Hose to the machine

- Connect the water supply hose to inlet valve of the washing machine, and then lock it by turning the hose connecting part.
- Check to see if there is a rubber seal inside the connector.
- A new washing machine should be installed with new hoses. The old hoses should not be reused.

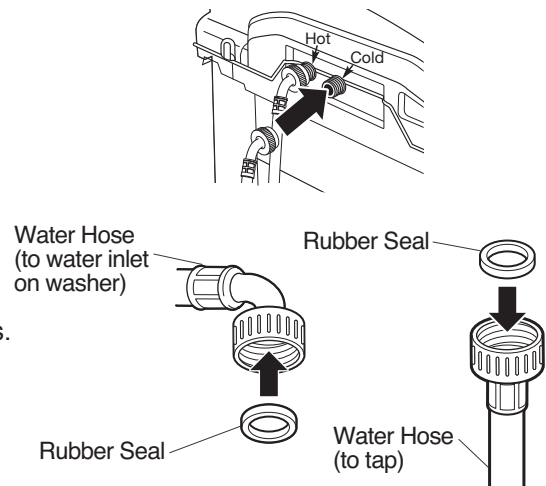

2-3. CONNECT THE DRAIN HOSE

- Connect the drain hose to the outlet of the drain pump located at the rear of the washing machine.

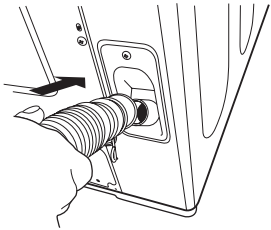

- Attach the clip to the drain hose. And then push it toward the body of the washing machine as indicated by the arrow.

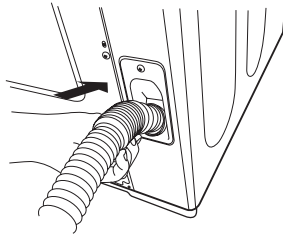

- Check that the drain hose is hung up over the edge of the laundry tub.
- Do not use an extension hose.

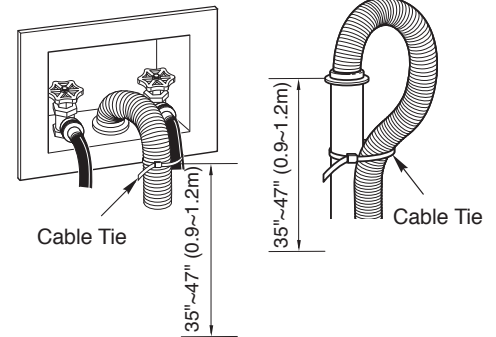

- NOTE :**
- The drain hose should always be properly secured. Failure to properly secure the drain hose can result in flooding and property damage.
 - The end of the drain hose should be placed 39" (99 cm) from the floor.
 - The drain must be installed in accordance with any applicable local codes and regulations.
 - Make sure that the water lines are not stretched, pinched, crushed, or kinked.
 - Do not insert the drain hose more than 12" (30 cm) into the drain pipe to avoid siphoning and odor build-up.

⚠ WARNING:

- The washer should never be installed or stored in a location subject to freezing temperatures. If the washer was exposed to freezing temperatures prior to installation, allow it to stand at room temperature for several hours before use. Damage to the water lines and internal mechanisms of the washer can result.
- Water supply pressure must be between 14.5 psi and 116 psi (100 ~ 800kPa). If the water supply pressure is more than 116 psi, a pressure reducing valve must be installed. If you have uncontrolled water temperature and pressure you should fit a temperature and pressure relief valve to ensure that water temperature and water pressure remain within the safe limits. Consult a plumber or electrician if you are unable to adjust water temperature and or pressure. Failure to do so can result in damage to the machine.
- Plug the power cord of washer into a properly grounded outlet. Failure to do this can result in shock or serious injury.

3. OPERATING INSTRUCTION

3-1. IDENTIFICATION OF PARTS

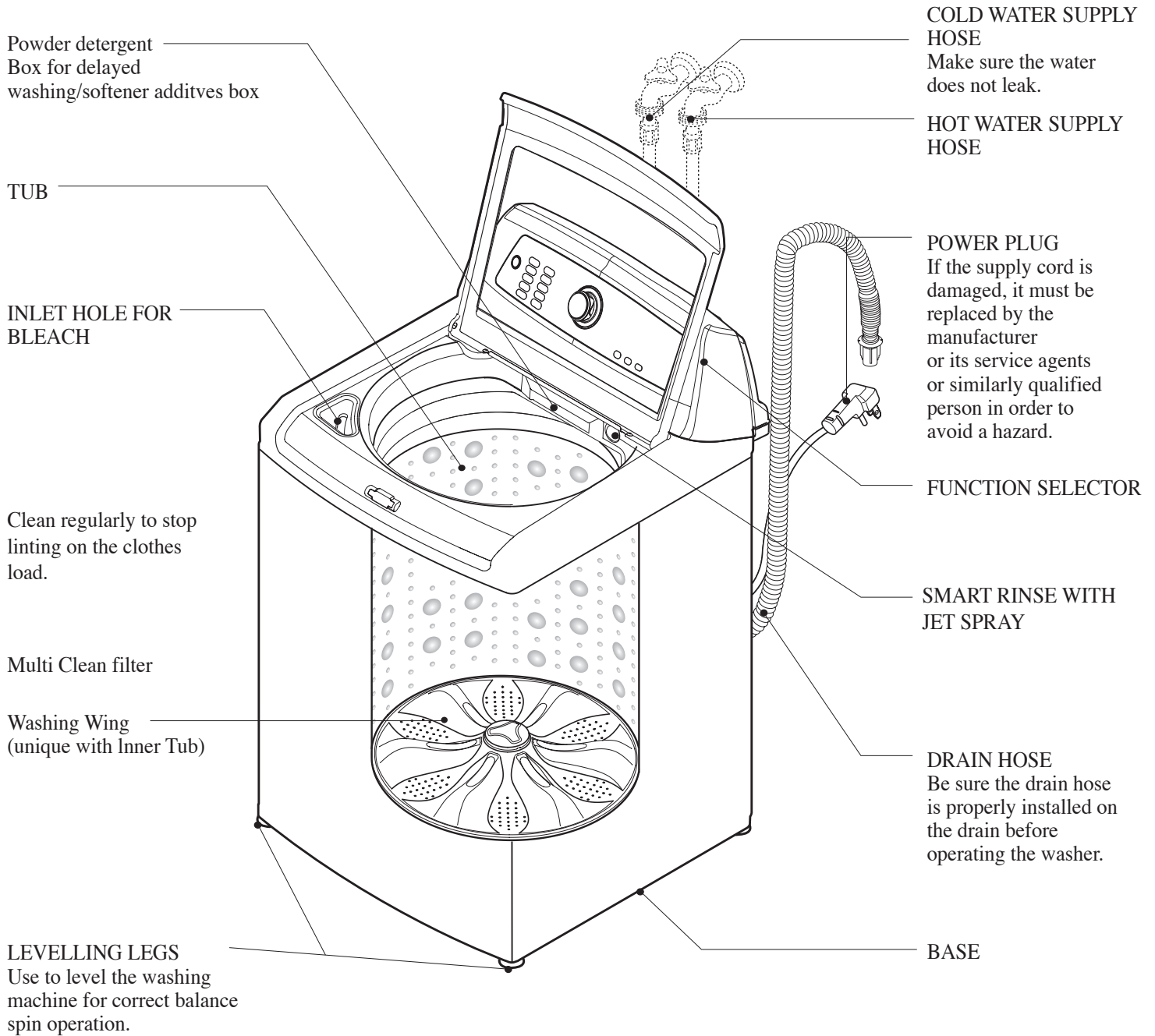

3-2. BEFORE STARTING TO WASH

Care Labels

- Look for a care label on your clothes.

This will tell you about the fabric content of your garment and how it should be washed.

Sort clothes into loads that can be washed with the same wash cycle, water temperature, and spin speed.



Sorting

To get the best results, different fabrics need to be washed in different ways.

- **SOIL** (Heavy, Normal, Light) Separate clothes according to the type and amount of soil.
- **COLOR** (Whites, Lights, Darks) Separate white fabrics from colored fabrics.
- **LINT** (Lint producers, Collectors) Separate lint producers and lint collectors.
Lint Producers Terry cloth, Chenille, Towels, Diapers
Lint Collectors Synthetics, Corduroy, Permanent Press, Socks

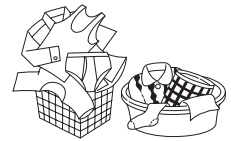

Check before Loading

- **Check all pockets to make sure that they are empty.** Things such as nails, hairclips, matches, pens, coins, and keys can damage both your washer and your clothes.
- **Mend any torn garments or loose buttons.** Tears or holes may become larger during washing.
- Remove belts, underwires, etc. to prevent damage to the machine or your clothes.
- **Pretreat any dirt and stains.**
- Make sure the clothes are washable in water.
- Check the washing instructions.
- Remove any paper or tissue in the pockets.
- **WIRE**

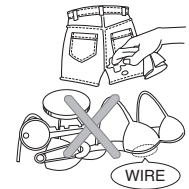

Pretreatment on stains or heavy soil

- Pretreat shirt collars and cuffs with a pre-wash product or liquid Detergent when placing them in the washer. Before washing treat special stains with bar soaps, liquid detergent or a paste of water and granular detergent.
- Use a pretreat soil and stain remover.
Treat stains AS SOON AS POSSIBLE. The longer they are left, the harder they are to remove.
(For more detail refer to page 14)

Loading

Do not wash fabrics containing flammable materials(waxes, cleaning fluids, etc.).

Load Size

The WATER LEVEL should just cover the clothes. Adjust the load size accordingly. Loosely load clothes no higher than the top row of holes in the washer tub. To add items after washer has started, press the Start button and submerge additional items. Close the lid and press the Start button again to restart.

- ※ Do not wash waterproofed fabrics (such as skiing outfits, diapers, or nappy auto seat covers.)

Light and Large-sized clothing

Clothes like downs and woollens are light weight, large and float easily. Use a nylon net and wash them in a small amount of water. If the laundry floats during the wash cycle, it may become damaged. Use dissolved detergent to prevent the detergent from clumping.

- ※ Do not wash water-proof textiles (Skiing outfit, baby diaper, nappy automobile seat covers.)

Long laundry items

Use nylon bag nets for long, **DELICATES** items. For laundry with long strings or long length, a bag will prevent tangling during washing. **Fasten zippers, hooks, and strings** to make sure that these items don't snag on other clothes.

- ※ The nylon washing bag is not supplied by LG.

⚠ WARNING

Fire Hazard

Never place items in the washer that are dampened with gasoline or other flammable fluids.
No washer can completely remove oil.
Do not dry anything that has ever had any type of oil on it (including cooking oils).
Doing so can result in death, explosion, or fire.



1) Using Water

Water Temperature

- The machine sets the appropriate temperature automatically according to the wash program .
You can override the preset selection by pressing the **Water Temp.** button.
 - The temperature of the water impacts the effectiveness of all laundry additives and therefore, the cleaning results.
 - We recommend temperatures of:
 - HOT 120°F (120-140°F) White items, diapers, underclothing and heavily soiled, colorfast items.
 - WARM 90°F (85-105°F) Most items
 - COLD 66°F (65-75°F) Only very bright colors with light soil.
 - When washing in COLD water additional steps may be needed:
 - Adjust Detergent amount and pre-dissolve Detergent in WARM water
 - Pretreat spots and stains
 - Soak heavily soiled items
 - Use appropriate bleach
- * Temperature below 18°C (65°F) will not activate laundry additives and may cause lint, residue, poor cleaning, etc. In addition, detergent manufactures and care labels define COLD water as 26~29°C...(80-85°F).
If the temperature of the water in the tub is too cold for your hands, the detergent will not activate and clean effectively.

Note

If iron is present in the water the clothes may become an all-over yellow or they may be stained with brown or orange spots or streaks. Iron is not always visible. Installation of water softener or an iron filter may be necessary for severe cases.

2) Using Detergent

Detergent

Follow the detergent package directions. Using too little detergent is a common cause of laundry problems. Use more detergent if you have hard water, large loads, greasy or oily soils or lower water temperature.

Choosing the right detergent

Your washing machine is designed for use with only High-Efficiency (HE) detergents. HE detergents are formulated specifically for Top-load washers and contain suds-reducing agents. Always look for the HE symbol when purchasing detergent. HE detergents produce fewer suds, dissolve more efficiently to improve washing and rinsing performance, and help to keep the interior of your washer clean. Using a regular detergent will cause unsatisfactory performance, oversudsing, machine build-up, and could damage the machine.

Using the Liquid Bleach Dispenser

The bleach dispenser automatically dilutes and dispenses liquid chlorine bleach at the proper time in the wash cycle.

1. Check clothing care labels for special instructions.
2. Measure liquid bleach carefully, following instructions on the bottle.
 - Never pour undiluted liquid chlorine bleach directly onto clothes or into the wash basket.
 - Do not pour powdered bleach into bleach dispenser.
 - Avoid overfilling or splashing when adding bleach to the dispenser. The maximum capacity of the bleach dispenser is one cup of bleach per wash cycle. Overfilling could result in premature dispensing of bleach.
3. Before starting the washer, pour measured amount of bleach directly into bleach dispenser. If you prefer to use powdered bleach, add it into the wash basket directly before adding clothes.

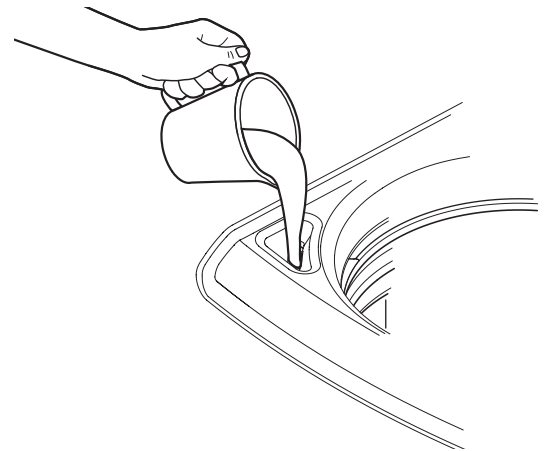

⚠ WARNING: Do NOT mix chlorine bleach with ammonia or acids, such as vinegar or rust / scale remover. Mixing chemicals like these can produce irritating and toxic fumes. Put the manufacturer's recommended amount of undiluted liquid chlorine bleach into the bleach dispenser. During the final portion of the wash cycle, two sequential flushes of the dispenser put all the bleach into the wash load and completely flush the dispenser to eliminate the carryover of bleach to a subsequent load. Any liquid remaining in the bleach dispenser at the end of the cycle is water, not bleach. To prevent unintentional self-siphoning of the bleach, never fill the dispenser higher than the maximum fill level marked on the dispenser. When adding bleach to the dispenser, be careful to avoid spilling it into the laundry load or leaving droplets of bleach around the dispenser. These things will damage your laundry items.

Using the Dispenser Drawer

ABOUT THE DISPENSER

The automatic dispenser consists of two compartments which hold:

- Liquid fabric softener.
- Liquid or powdered detergent.

All laundry products can be added at once in their respective dispenser compartments. They will be dispensed at the appropriate time for the most effective cleaning. After adding the laundry products to the dispenser, close the dispenser drawer.

To add detergent, bleach, and fabric softener to the automatic dispenser:

- ① Open the dispenser drawer.
- ② Load the laundry products into the appropriate compartments.
- ③ Close the lid slowly and smoothly to avoid spilling, splashing, or premature dispensing of the contents.

NOTE: It is normal for a small amount of water to remain in the dispenser compartments at the end of the cycle.

NOTE: Do not use powdered or liquid bleach in the dispenser drawer.

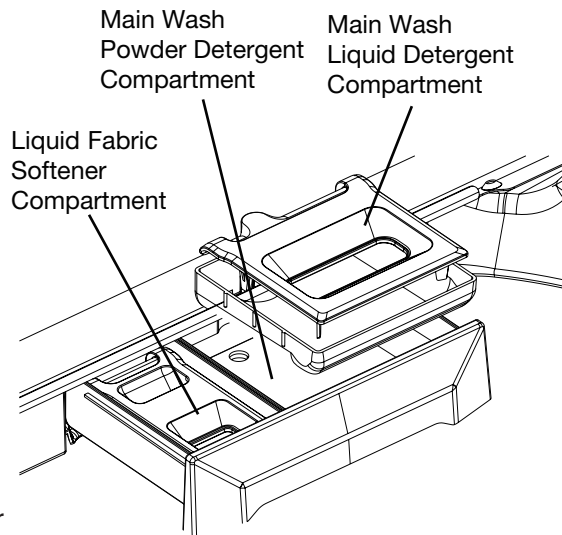

Adding Detergent

Add measured detergent to the detergent compartment of the dispenser drawer.

- **Do not exceed the maximum fill line.**

Detergent is flushed through the dispenser at the beginning of the wash phase. Either powdered or liquid detergent can be used, but the drawer insert must be removed to use powder.

Detergent usage may need to be adjusted for water temperature, water hardness, size and soil level of the load. Avoid using too much detergent in your washer, as it can lead to oversudsing and detergent residue being left on the clothes.

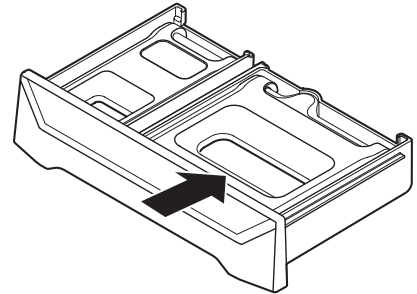

Adding Fabric Softener

Pour the recommended amount of liquid fabric softener into the left-hand compartment. Use only liquid fabric softener.

Dilute with water to the maximum fill line.

- **Do not exceed the maximum fill line.**

Overfilling can cause early dispensing of the fabric softener, which could stain clothes.

NOTE: Do not pour fabric softener directly on the wash load. It may stain the clothes.

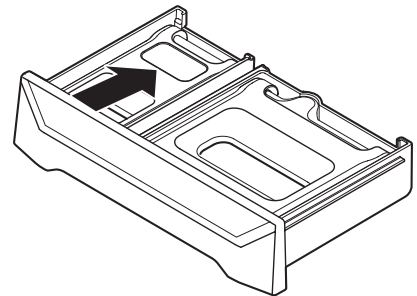

Adding Wash Boost Additives

The Wash Boost dispenser may be used to clean heavily soiled or stained garments more efficiently.

If desired, place the additives for the wash boost setting in the right-hand compartment. Use only liquid additives.

- **Do not exceed the maximum fill line to avoid**

Overfilling can cause early dispensing of presoak additives, which could result in damaged clothes.

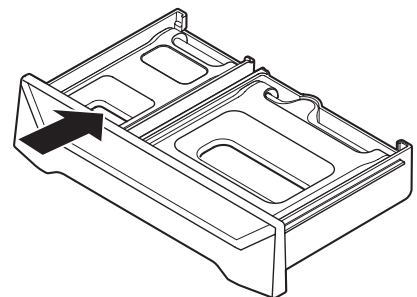

NOTE : Do not pour additives directly on the wash load. It may stain the clothes.

3) Special Guide for Stain Removal

WARNING

Do not use or mix liquid chlorine bleach with other household chemicals such as toilet cleaners, rust removers, acid, or products containing ammonia. These mixtures can produce dangerous fumes which can cause serious injury or death.

To reduce the risk of fire or serious injury to persons or property, comply with the basic warnings listed below:

- Read and comply with all instructions on stain removal products.
- Keep stain removal products in their original labeled containers and out of children's reach.
- Thoroughly wash any utensil used.
- Do not combine stain removal products, especially ammonia and chlorine bleach. Dangerous fumes may result.
- Never wash items which have been previously cleaned in, washed in, soaked in or spotted with gasoline, dry cleaning solvents, or other flammable or explosive substances because they give off vapors that could ignite or explode.
- Never use highly flammable solvents, such as gasoline, inside the home. Vapors can explode on contact with flames or sparks.

For successful stain removal:

- Remove stains promptly.
- Determine the kind of stain, then follow the recommended treatment in the stain removal chart below.
- To pretreat stains, use a prewash product, liquid detergent, or a paste made from granular detergent and water.
- Use COLD water on unknown stains because HOT water can set stains.
- Check care label instructions for treatments to avoid on specific fabrics.
- Check for colorfastness by testing stain remover on an inside seam.
- Rinse and wash items after stain removal.



Stain Removal

STAIN	TREATMENT
Adhesive tape, chewing gum, rubber cement	Apply ice. Scrape off excess. Place stain face down on paper towels. Saturate with prewash stain remover or nonflammable dry cleaning fluid.
Baby formula, dairy products, egg	Use product containing enzymes to pretreat or soak stains.
Beverages (coffee, tea, soda, juice, alcoholic beverages)	Pretreat stain. Wash using COLD water and bleach safe for fabric.
Blood	Soak the item in a bowl of COLD water for at least 30 minutes. Then launder as usual.
Candle wax, crayon	Remove all surface wax. Put the garment in the freezer for a couple of hours, then remove and break away as much wax as possible. Try a commercial removal product like Goo-Gone, Goop, or Go-Jo cleaner for the remaining wax stains. DO NOT ATTEMPT TO REMOVE WITH HEAT!
Chocolate	Pretreat or soak in WARM water using product containing enzymes. Wash using bleach safe for fabric.
Collar or cuff soil, cosmetics	Pretreat with prewash stain remover or rub with bar soap.
Dye transfer on white fabric	Use packaged color remover. Wash using bleach safe for fabric.
Grass	Pretreat or soak in WARM water using product containing enzymes. Wash using bleach safe for fabric.
Grease, oil, tar (butter, fats, salad, dressing, cooking oils, car grease, motor oils)	Scrape residue from fabric. Pretreat. Wash using hottest water safe for fabric. For heavy stains and tar, apply nonflammable dry cleaning fluid to back of stain. Replace towels under stain frequently. Rinse thoroughly. Wash using hottest water safe for fabric.
Ink	Some inks may be impossible to remove. Washing may set some inks. Use prewash stain remover, denatured alcohol, or nonflammable dry cleaning fluid.
Mildew, scorch	Wash with chlorine bleach if safe for fabric. Or, soak in oxygen bleach and HOT water before washing. Badly mildewed fabrics may be permanently damaged.
Mud	Brush off dry mud. Pretreat or soak with product containing enzymes.
Mustard, tomato	Pretreat with prewash stain remover. Wash using bleach safe for fabric.
Nail polish	May be impossible to remove. Place stain face down on paper towels. Apply nail polish remover to back of stain. Repeat, replacing paper towels frequently. Do not use on acetate fabrics.
Paint, varnish	WATER BASED Rinse fabric in cool water while stain is wet. Wash. Once paint is dry, it cannot be removed, OIL BASED AND VARNISH Use solvent recommended on can label. Rinse thoroughly before washing.
Rust, brown or yellow discoloration	For spots, use rust remover safe for fabric. For discoloration of an entire load, use phosphate Detergent and nonchlorine bleach. Do not use chlorine bleach because it may intensify discoloration.
Shoe polish	LIQUID Pretreat with a paste of granular detergent and water. Paste scrape residue from fabric. Pretreat with prewash stain remover or nonflammable dry cleaning fluid. Rub detergent into dampened area. Wash using bleach safe for fabric.

3-3. FUNCTION OF EACH BUTTON.

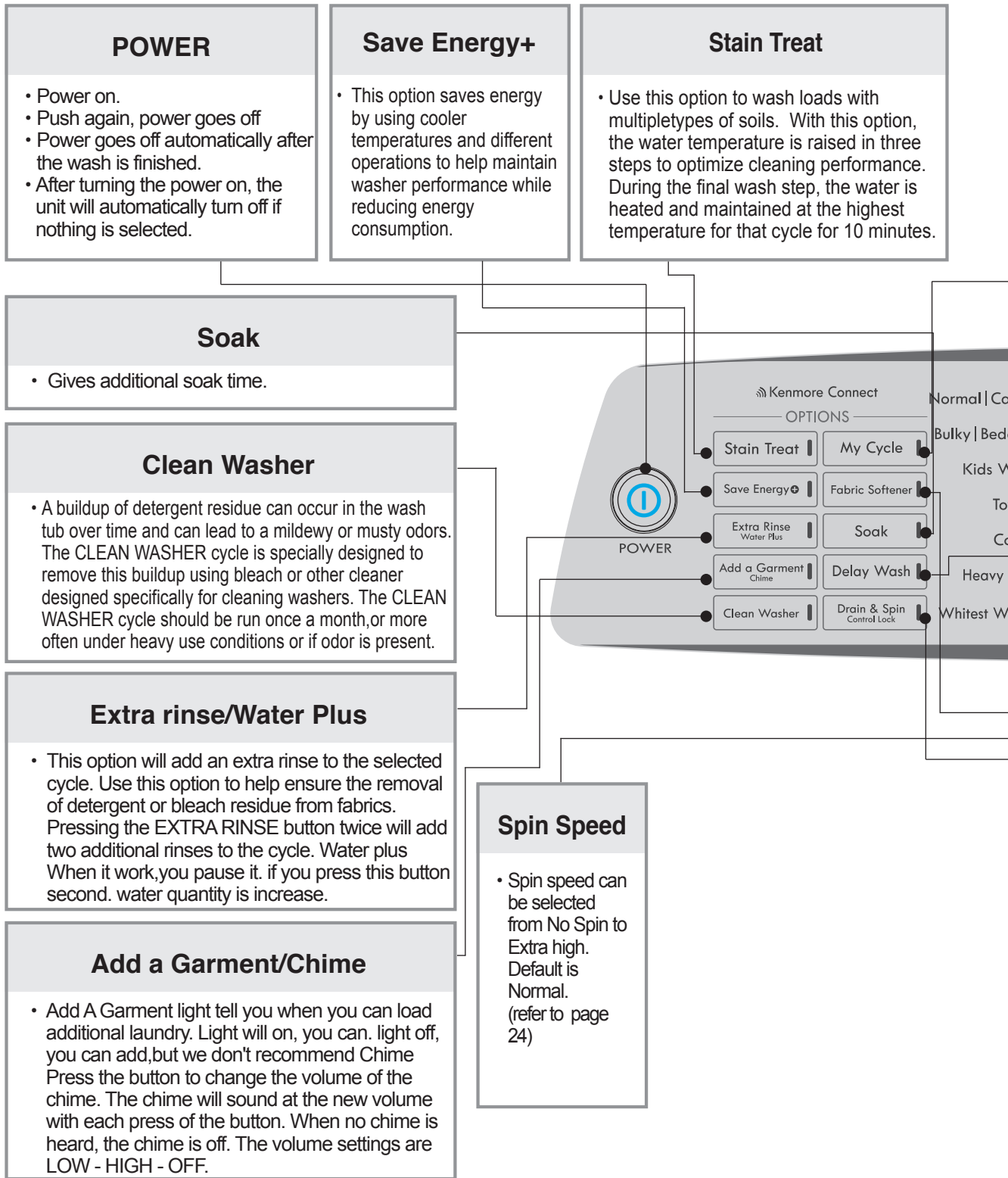

Note

The time shown on the display is the estimated cycle time. If the sensors and microprocessor elect to make changes during the cycle, the display will be adjusted accordingly.

My Cycle

- MYCYCLE allows you to store a customized wash cycle for future use. It allows you to save favorite temperature, spin speed, soil level, and other options for a cycle, and then recall them at the touch of a button.

Delay Wash (Selection) BUTTON

- Delayed finishing time.
- The time increases when the button is pushed.
- The following settings are indicated as the button is pushed 1 ▶ 2 ▶ 3 ▶ 4 ▶ ... 17 ▶ 18 ▶ 19 ▶
▶ Reservation off ▶ 1 ...
- To cancel delay time, turn the power switch off or push DELAY WASH button until off.

START/ PAUSE BUTTON

- Use to start or pause the wash cycle.
- Changes while be made to the wash settings while the machine is paused.
- Repeats start and pause by pushing the button.



CYCLE BUTTON

- Use for selecting wash program.
- This button allows the selection of 10 different programs for different kinds of laundry and dirtiness.
- Program selections light up in sequence as follows:
Normal/Casual ▶ Cold Clean ▶ Heavy duty ▶ Bulky/ bedding ▶ Whitest Whites ▶ Rinse/Spin ▶ Sanitize ▶ Kids Wear ▶ Towels ▶ Workout Wear ▶ Colors ▶ Express Wash ▶ Handwash/Wool Delicates select the desired program by ressing the button.

Cold Clean

- Runs a cycle without hot water or the wash heater, For greater efficiency, we recommend washing a small load (less than 8 pounds) and a low spin speed.

Fabric Softener

- Causes the dispensing of fabric softener in the final rinse cycle.

Wash Temp.

- Select to select Wash Temperature.
- Pressing the button allows The selection of Tap Cold ▶ Cold ▶ Warm ▶ Hot ▶ Extra Hot respectively. Default setting is Warm.

Soil Level

- Allows a selection to be made for the strength of the wash action.
- Power option selections light up in sequence as follows Normal ▶ Heavy ▶ Light ▶ Normal as the button is pushed. This can be selected for any program.
- Adjustment can be made while washing.
- Default SOIL LEVEL is Normal.

Drain & Spin/ Control Lock

- Before washer is operating. Use when you want only spin, While washer is operating. If you press 5second.all controls except CONTROL LOCK and POWER buttons will be disabled. If you want to deactivate. press it again 5second

3-4. WASHING PROGRAMS.

CYCLE GUIDE

The cycle guide below shows the default settings, available options and recommended fabric types for each cycle. Allowable modifier adjustments are shown below the default setting for each cycle.

● = Available Option

■ = Default Setting

Cycle	Fabric or Load Type	Wash Temperature	Spin Speed	Soil Level	Stain Treat	Save Energy	Extra Rinse	Water Plus	Add a Garment
Normal/ Casual	Cotton, shirts, jeans socks, pants	Warm	High	Normal					
		Hot Cold Tap Cold	Extra High No Spin Medium	Heavy Light	●	●	●	●	●
Bulky/ Bedding	Large items such as blankets and comforters	Warm	Medium	Normal					
		Cold Hot Tap Cold	Extra High High No Spin Low	Heavy Light			●		●
Kids Wear	Specifically designed to clean and thoroughly rinse kids wear	Warm	High	Light					
		Hot Cold	Extra High No Spin Low Medium	Normal Heavy			●	●	●
Towels	Towels	Warm	High	Normal					
		Cold Hot Tap Cold	Extra High No Spin Low Medium	Heavy Light	●		●	●	●
Colors	Lightly soiled and colored clothing	Tap Cold	Medium	Normal					
		Cold Warm	High Extra High No Spin Low	Heavy Light			●	●	●
Heavy Duty	Heavy soiled cotton fabrics	Warm	High	Heavy					
		Cold Hot Tap Cold	Extra High Medium Low No Spin	Light Normal	●		●	●	●

NOTE:

To protect your garments, not every wash temperature, spin speed, soil level, or option is available with every cycle. A chime will sound and the LED will not light if the selection is not allowed.

*When a cycle is selected, the default time for that cycle is displayed. This time will change as modifiers or options are selected. Once the START/PAUSE button is pressed, the washer will measure the size of the load. The estimated time may change once the load size has been measured. The washer automatically adjusts the wash time for the amount of laundry, water pressure, water and other operating conditions.

These cycles use various wash motions to enhance cleaning and/or fabric care performance. The wash motions may sound different at different stages of the wash cycle. This is normal.

CYCLE GUIDE

The cycle guide below shows the default settings, available options and recommended fabric types for each cycle. Allowable modifier adjustments are shown below the default setting for each cycle.

● = Available Option

■ = Default Setting

Cycle	Fabric or Load Type	Wash Temperature	Spin Speed	Soil Level	Stain Treat	Save Energy	Extra Rinse	Water Plus	Add a Garment
Whitest Whites	Heavily to normally soiled white cottons	Hot	Medium	Heavy					
		Warm	Extra High High Low No Spin	Light Normal			●	●	●
Express Wash	Lightly soiled clothing and small loads	Warm	High	Light					
		Cold Tap Cold	Extra High Medium Low No Spin	Normal Heavy			●	●	●
Cold Clean	Small loads of cotton, linen, towels, shirts, sheets, jeans, mixed loads	Tap Cold	High	Normal					
			Extra High No Spin Low Medium	Heavy Light			●	●	●
Sanitize	Heavily soiled items, such as work clothes, diapers, etc.	Extra Hot	High	Heavy					
			Extra High No Spin Low Medium	Light Normal			●		●
Delicates	Dress shirts/blouses, nylons, sheer or lacy garments	Tap Cold	Low	Light					
		Cold Warm	High Medium No Spin	Heavy Normal			●	●	●
Handwash/Wool	Items labeled "hand washable"	Warm	Low	Light					
		Cold Tap Cold	Medium No Spin	Normal Heavy			●	●	●
Workout Wear	Permanent press, synthetic items	Warm	Medium	Normal					
		Cold Tap Cold	High No Spin Low	Heavy Light			●	●	●
Rinse/Spin	Rinse and Spin	Tap Cold	High						
			Extra High Medium Low No Spin				●		

NOTE:

To protect your garments, not every wash temperature, spin speed, soil level, or option is available with every cycle. A chime will sound and the LED will not light if the selection is not allowed.

*When a cycle is selected, the default time for that cycle is displayed. This time will change as modifiers or options are selected. Once the START/PAUSE button is pressed, the washer will measure the size of the load. The estimated time may change once the load size has been measured. The washer automatically adjusts the wash time for the amount of laundry, water pressure, water and other operating conditions.

These cycles use various wash motions to enhance cleaning and/or fabric care performance. The wash motions may sound different at different stages of the wash cycle. This is normal.

3-5. CARE AND MAINTENANCE

When there is the possibility of freezing temperatures

- Close the water taps and remove the water supply hoses.
- Remove the water which remains in the water supply.
- Lower the drain hose and drain the water in the sump and the drain hose by running a spin cycle.

If frozen

- Remove the water supply hose and immerse it in HOT water. (40° C or 104° F).
- Pour approximately 2 liters (4½ pounds) of HOT water (40° C or 104° F) into the sump and allow it to stand for at least 10 minutes.
- Connect the water supply hose to the water tap run a SPEED WASH cycle to confirm that the machine fills, drains, and operates properly.

Wash Inner-Tub

Leave the lid open after washing to allow moisture to evaporate. If you want to clean the inner-tub use a clean soft cloth dampened with liquid detergent, then rinse. (Do not use harsh or gritty cleaners.)

Inlet Hoses

Hoses connecting washer to faucet should be replaced every 5 years.

Exterior

objects.

Immediately wipe off any spills. Wipe with damp cloth. Avoid hitting surface with sharp

Long Vacations

Be sure water supply is shut off at faucets. Drain all water from hoses if weather will be below freezing.

Cleaning the inside of your washer

If you use fabric softener or do regular COLD water washing, it is very important that you clean the inside of your washer occasionally as described below.

- Fill your washer with HOT water.
- Add 1 cup of bleach.
- Let it operate for several minutes.
- Stop the washer, open the lid, and leave it to soak overnight.
- After soaking, drain the washer and run it through a normal cycle.

Products that might damage your washing machine

- Concentrated bleaches and diaper sanitizer will cause damage to the paintwork and components of your washer.
- Hydrocarbon solvents, i.e. petrol, paint thinners and lacquer thinners, etc. can dissolve plastic and blister paint.
(Be careful when washing garments stained with these solvents as they are flammable, DO NOT put them in washer or dryer.)
- Some pretreatment sprays or liquids can damage your washer's control panel.
- Use of dyes in your washer may cause staining of the plastic components. The dye will not damage the machine but we suggest you thoroughly clean your washer afterwards. We do not recommend the use of dye strippers in your washer.
- Do not use your washer lid as a work surface.

4. SERVICE INFORMATION

4-1. WIRING DIAGRAM

WIRING DIAGRAM

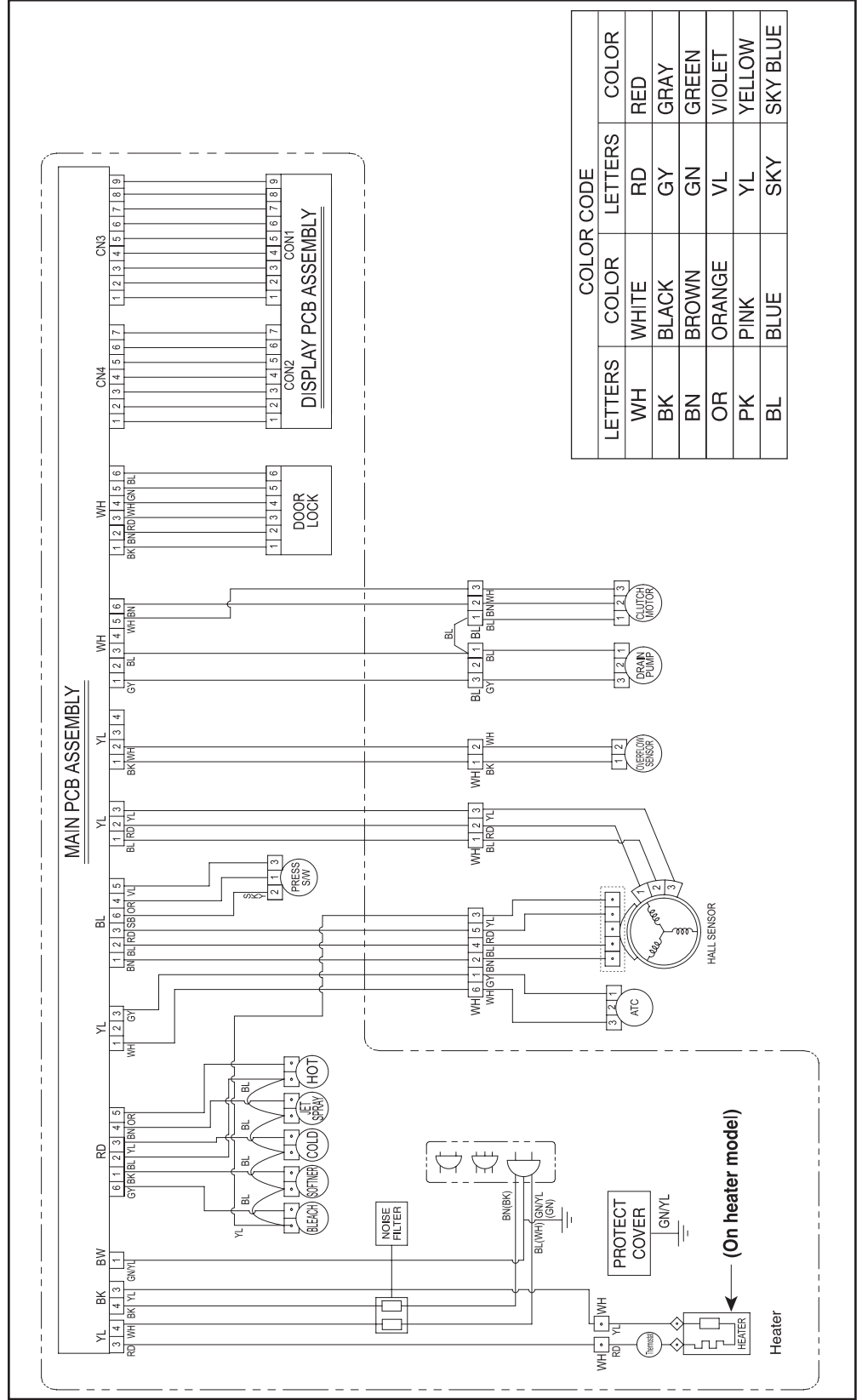

4-2. DISASSEMBLY INSTRUCCION

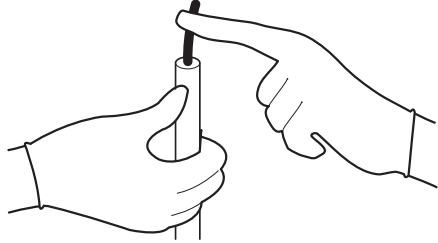

- ▶ Be sure to unplug the power to repair and replace electric parts.

ESD (ElectroStatic Discharge) WARNING

Be sure to follow proper ESD and grounding precautions for diagnosis and repair. If this is not possible, touch the ground wire on a regular basis to remove any static charge built up on your person.

1) Remove front panel and main PCB assembly

- ① Remove 5 panel fixing screws attaching the panel on the back.
- ② Disassemble Rear Panel.

- ③ Pull the front panel forward.
- ④ Disassemble the protective cover.
- ⑤ Disconnect the leads from the controller.

- ⑥ Remove 9 screws on the PCB assembly.
- ⑦ Disassemble PCB assembly.

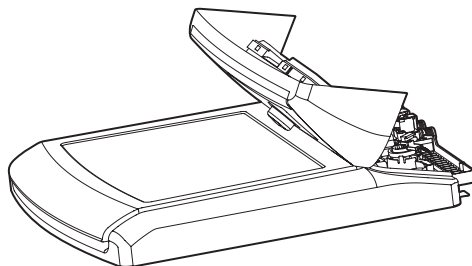
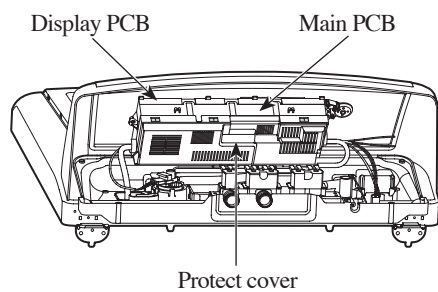
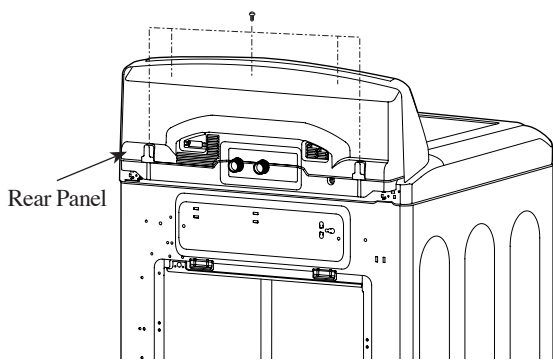

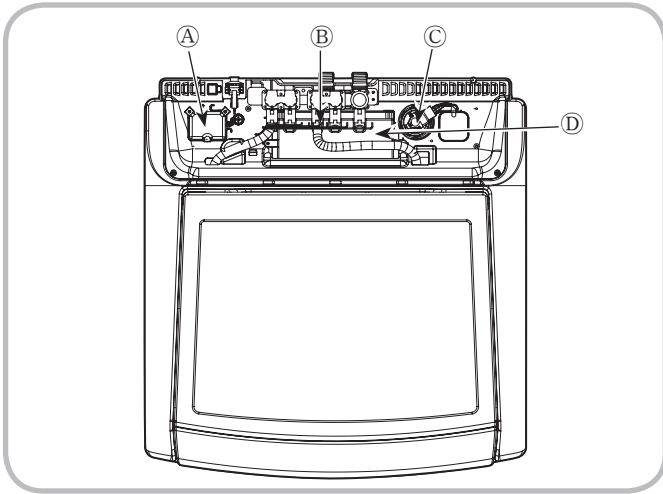

2) Disassembly of the Noise Filter, Power Cord, Inlet Valve, Pressure Switch, and DT Housing.

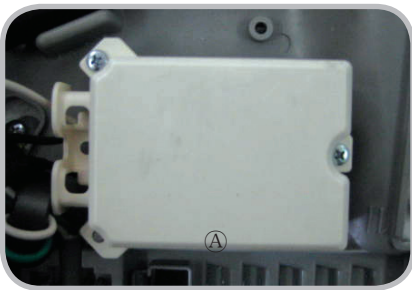

Noise Filter and Power Cord(Figure A)

- ① Remove the two screws attaching the noise filter.
- ② Disconnect 2 connector in Noise Filter and Disassemble Noise Filter and Power Cord.

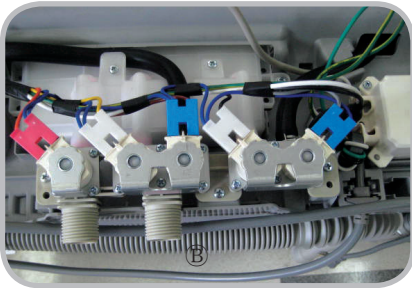

Inlet Valve (Figure B)

- ① Disconnect the leads from the inlet valve and remove three screws.
- ② Remove the hoses and output pipes from the input valve.
- ③ Remove the inlet valve.

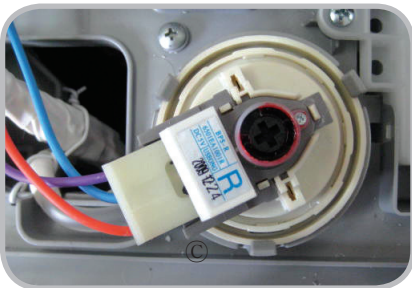

Pressure Switch (Figure C)

- ① Disconnect the leads from pressure switch and disassemble pressure switch
- ② Disconnect pressure tube from the pressure switch .

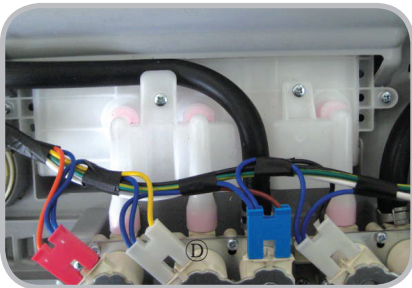

DT Housing (Figure D)

- ① Remove the hoses and output pipes from the input valve.
- ② Disassemble the connector pipe and the DT housing.

3) Disassembly of Top Cover and Lid

① Insert a flat blade between the cabinet and the top cover to release the latches.

② Lift the top cover.

③ Use the blade to push the left hinge out of the way and to displace the hinge pin to remove the lid.

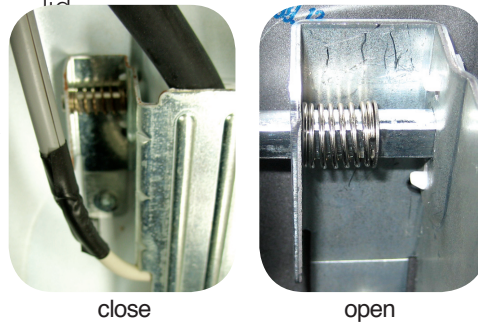

④ Remove the lid by pulling the right hinge pin out of its holder.

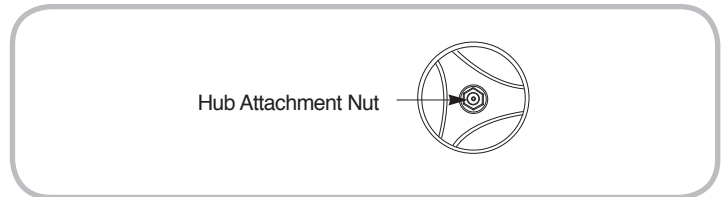
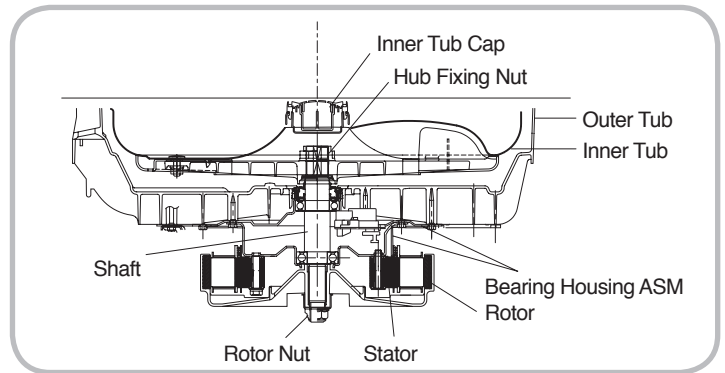
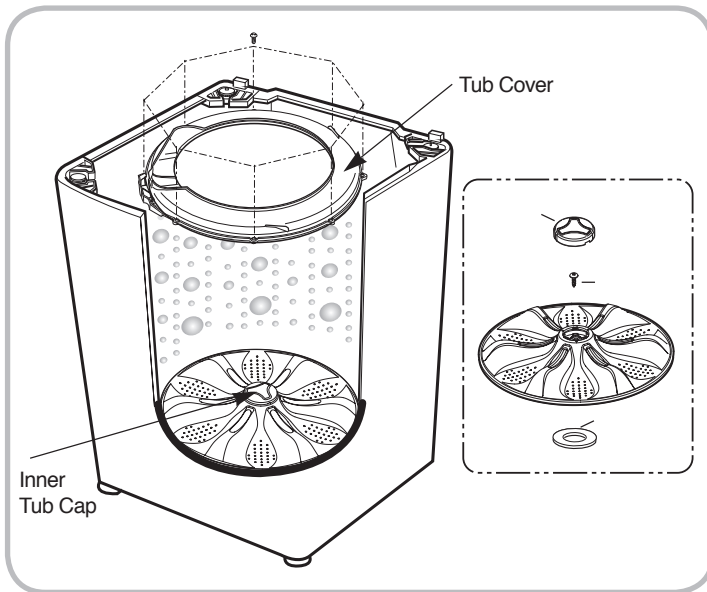

4) Disassembly of Tub Cover and Pulsator

- ① Remove 8 screws and take off the tub cover.
- ② Remove the pulsator cap.
- ③ Remove the pulsator screws and take it out.
- ④ Remove the pulsator washer and take it out.

5) Assemble the service tool (38 mm wrench)



6) Remove the hub attachment nut. (38 mm)

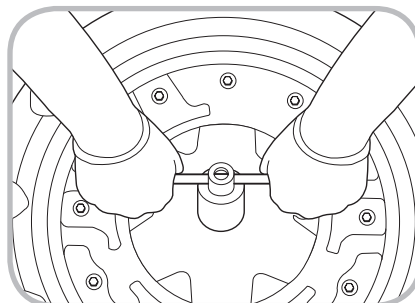
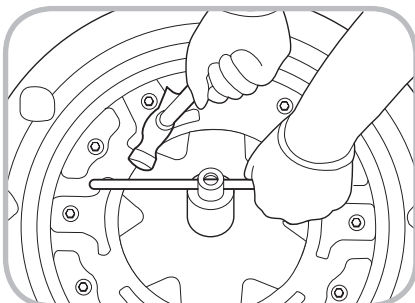

- ① Hit the bar using the hammer.
- ② Disconnect hub fixing nut and disassemble the inner tub.

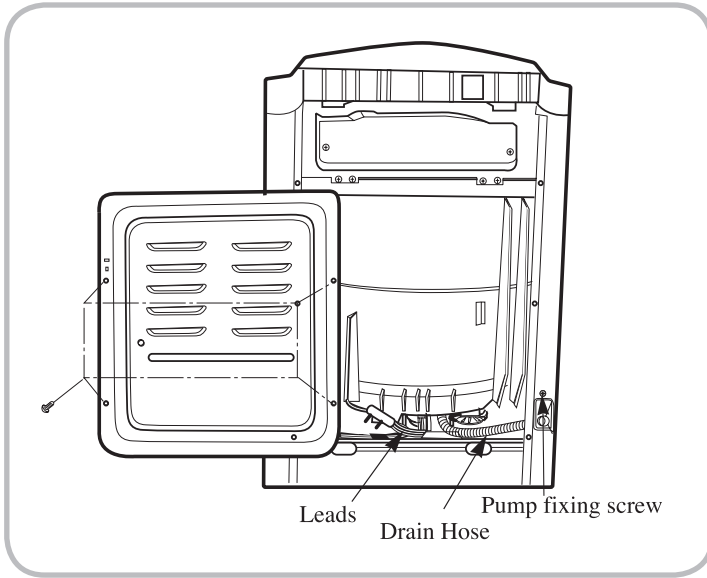

6) Disassembly of the Back Cover and Drain Pump

- ① Remove the screws that attach the back cover and take it off.
- ② Disconnect the leads and the drain hose from the drain pump.
- ③ Remove the pump attachment screws and the lead connector. Take the pump assembly out of the washer.



7) Disassembly of Damper Assembly

- ① Remove the top cover of the washing machine.
- ② As shown in the drawing, lift the damper assembly and remove it along with the outer tub assembly.
- ③ Damper assembly shall not be disassembled. Replace damper as assembly.

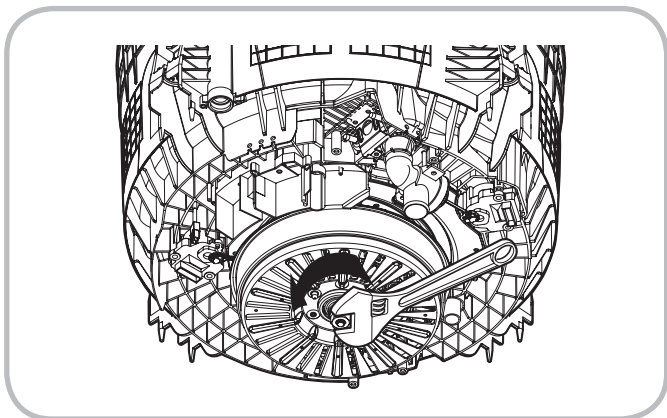

8) Disassembly of Rotor and Stator

- ① Use a wrench (M24) to remove the nut that connects the rotor to the shaft.
(The torque should be 200 kgf/cm or 88 foot-pounds.)
- ② Remove the rotor by pulling it straight off the splined shaft.

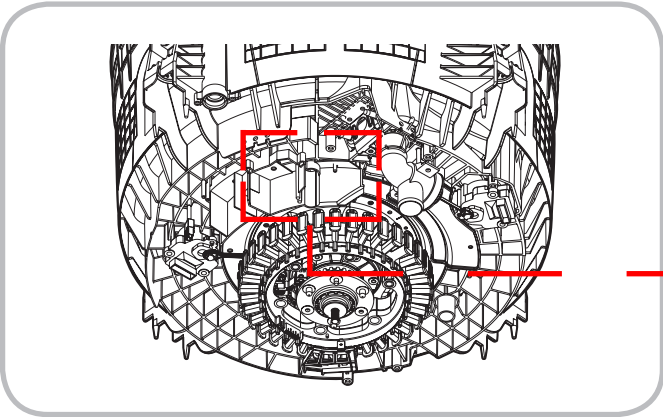

③ Remove the screws that secure the water guide.

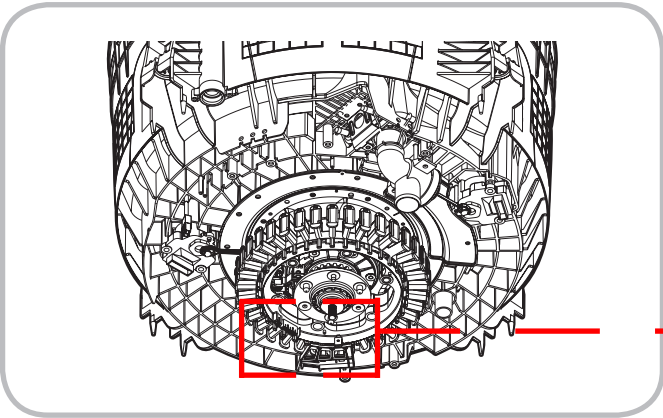
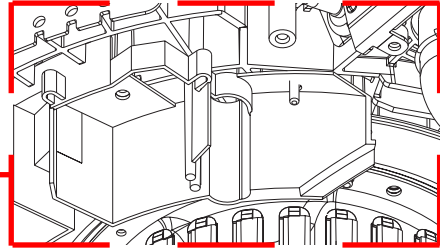

④ Disconnect the hall sensor and stator connection before removing the stator in the subsequent step.

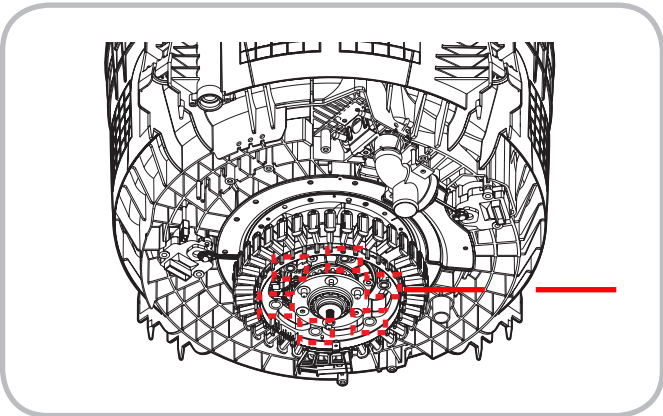
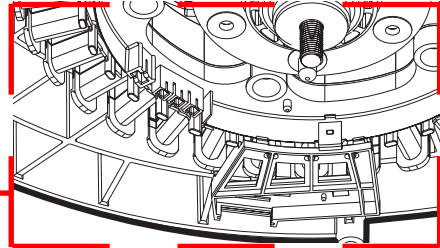

⑤ Remove the six screws securing the rotor.
⑥ Check the position of the snap ring, being sure it faces the rotor and stator.

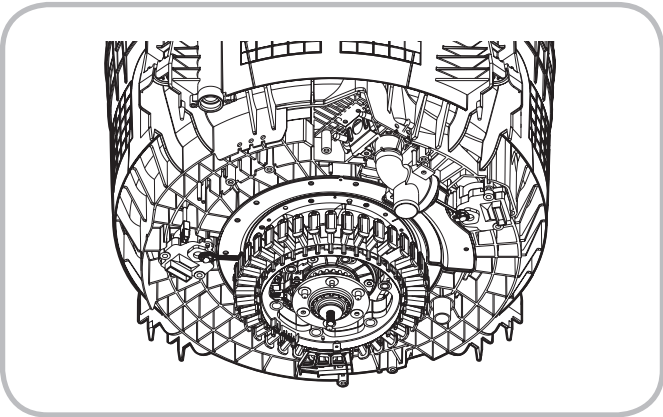
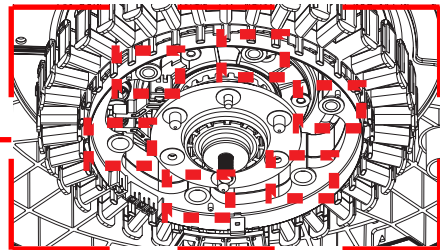

⑦ To keep from dropping the stator, loosen the six bolts almost all the way; then hold the stator in one hand while removing the bolts with the other.
⑧ Be careful during removal and replacement to avoid cutting, nicking, or pinching any of the wires. This could cause a short or electrical noise in the machine.

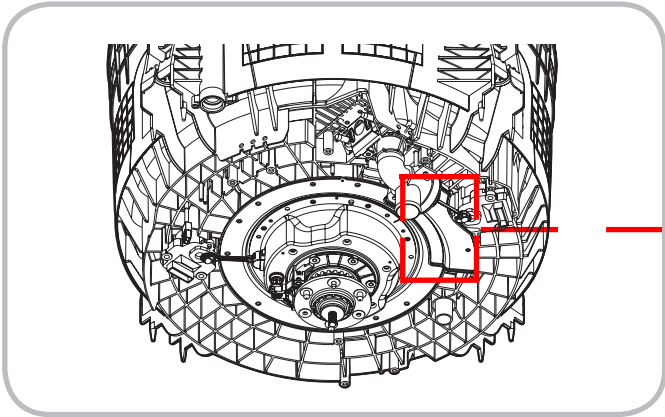

⑨ Remove four screws to release the tub bracket.

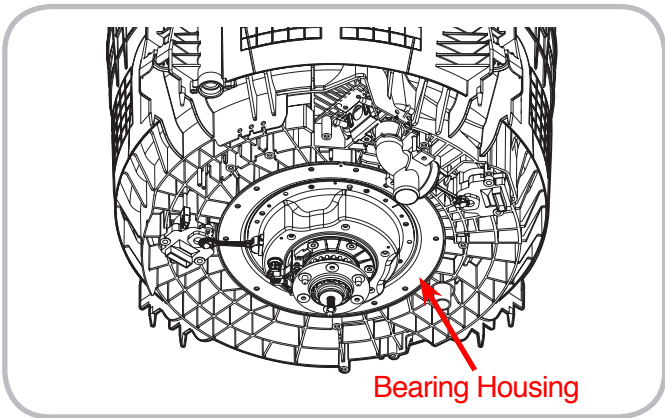
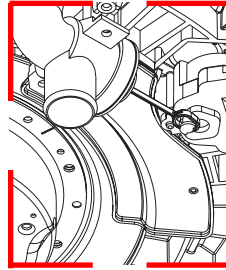

⑩ Remove 17 screws to release the bearing housing. Pull the housing away from the tub, but do not pry it with a screwdriver to avoid damage.

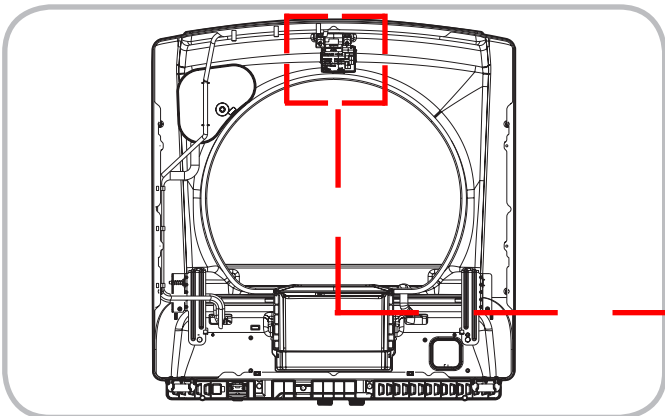

9) Disassembly of Door Lock Switch

- ① Remove the two door lock attachment screws.
- ② Remove the door switch and remove the attachment tube.

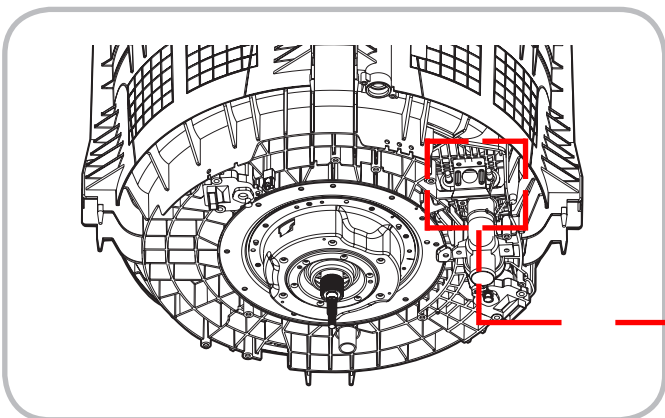
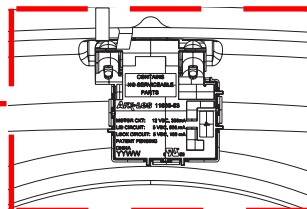

10) Disassembly of Heater

- ① Remove the three heater attachment screws.
- ② Loosen the nut at the middle of the heater to relieve the tension on the clamp. Then pull it out of the case.

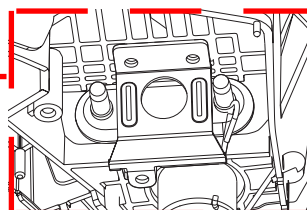

4-3. TEST RUNNING WITHOUT WATER

1) SAFETY CAUTION

- The main power board assembly has exposed live 120 VAC and live DC voltages. Use care when disconnecting connectors during troubleshooting and testing. (Wear electrostatic discharge gloves when handling the board.)
- Unplug the power when handling the board assembly. (Wear electrostatic discharge gloves when handling the board. Store the board in an ESD [ElectroStatic Discharge] plastic bag.)

2) SERVICE MODE

- The washer must be empty and the controls must be in the off state.
- Press and hold the SOAK and ADD A GARMENT buttons; then press the POWER button. The buzzer will sound twice.
- Press the Start/Pause button to advance to the subsequent test mode step.

Number of times the START/PAUSE button is pressed	Check Pont	Display Status
None	Main program version	T1 and Main Program Version
1 time	Display program version	T2 and Display Program Version
2 time	None	T3
3 time	Inlet valve for Bleach Detergent turns on. (Cold Water)	A and Water level frequency (1~10 Level)
4 time	※ On :67~33(26.7kHz~23.3kHz) Inlet valve for Softener Dispenser turns on. (Hot Water)	※ The meaning of 67~33 number is 26.7kHz~23.3kHz really B and Water level frequency (1~10Level)
5 time	Inlet valve for J-Dispenser turns on. (Cold Water)	C and Water level frequency (1~10Level)
6 time	Heater check (on heater model)	T4 and the coefficient of flood sensing
7 time	Wave force check	T5 and the coefficient of load sensing
8 time	Drain pump and agitate (pulsator) check	T6 and Water level frequency
9 time	Agitate (tub) check	T7 and the coefficient of load sensing
10 time	High speed spin	T8 and RPM
11 time	Off . Unlocks the door . Turns off all LED	None

4-4. TROUBLESHOOTING BY COMMON WASHING PROBLEMS

Many washing problems involve poor soil and stain removal, residues of lint and scum, and fabric damage. For satisfactory washing results, follow these instructions.

NOTE: NEVER use bar soap in the washing machine.

WASHING PROBLEM

Problems	Possible Causes	Solutions and Preventive Measures
Poor soil removal	<ul style="list-style-type: none"> · Insufficient detergent · Wash water temperature too low · Incorrect wash cycle · Laundry missorted · Stains not properly pretreated 	<ul style="list-style-type: none"> · Use correct amount of detergent for load size, amount of soil and water hardness. · Use WARM or HOT water for normal soil. Different Water Temperature may be required according to soil type. (<i>refer to page 10</i>) · Reduce load size. · Wash with Heavy or Soak & Heavy wash cycle for heavy soiled laundry. · Separate heavily soiled items from lightly soiled ones. · Pretreat stain and heavy soil according to directions shown on page 15.
Blue Stains	<ul style="list-style-type: none"> · Undiluted fabric softener dispensed directly onto fabric 	<ul style="list-style-type: none"> · Pretreat the stain with detergent or a stain removal agent. · Do not overfill fabric softener dispenser and do not pour liquid fabric softener directly onto fabric. See page 13 for more instructions.
Black or gray marks on clothes	<ul style="list-style-type: none"> · A buildup caused by the interaction of fabric softener and detergent can flake off and mark clothes · Not enough detergent 	<ul style="list-style-type: none"> · Keep the recommendations against Scrud (waxy buildup). · Use correct amount of detergent for load size, soil level, and water Hardness.
Yellow or brown rust stains	<ul style="list-style-type: none"> · Iron or manganese in water supply, water pipes, or water heater 	<ul style="list-style-type: none"> · To restore discolored load of whites, use rust remover safe for fabric. · Install nonprecipitating water softener or an iron filter in your water supply system for an ongoing problem. · Before washing, run water for a few minutes to clear lines.
Lint	<ul style="list-style-type: none"> · Incorrect sorting · Tissues left in pocket · Overloading the washer 	<ul style="list-style-type: none"> · Wash lint-producing items, like flannel sheets, towels, and the like separately from dark fabrics and fabrics that tend to collect lint. Remove all items, including tissues and papers, from the pockets of items to be washed. See page 9 for sorting information. · Do not overload the washer
Residue or Detergent	<ul style="list-style-type: none"> · Overloading the washer · Undissolved detergent · Excessive detergent 	<ul style="list-style-type: none"> · Do not overload the washer. · Some detergents need to be pre-dissolved, check the detergent instructions. Try pre-dissolving the detergent. · Increase Water Temperature using HOT water safe for fabric. · Use proper amount of detergent.
Holes, tears, or snags	<ul style="list-style-type: none"> · Incorrect use of chlorine bleach. · Unfastened zippers, hooks, buckles · Ribs, tears and broken threads · Overloading the washer · Degradation of fabric 	<ul style="list-style-type: none"> · Never pour chlorine bleach directly on fabric. See page 11 for adding liquid bleach. · Fasten zippers, hooks, and buckles. · Remove objects in pockets. See page 9 for caring before loading. · Do not overload the washer.

4-5. TROUBLESHOOTING SUMMARY

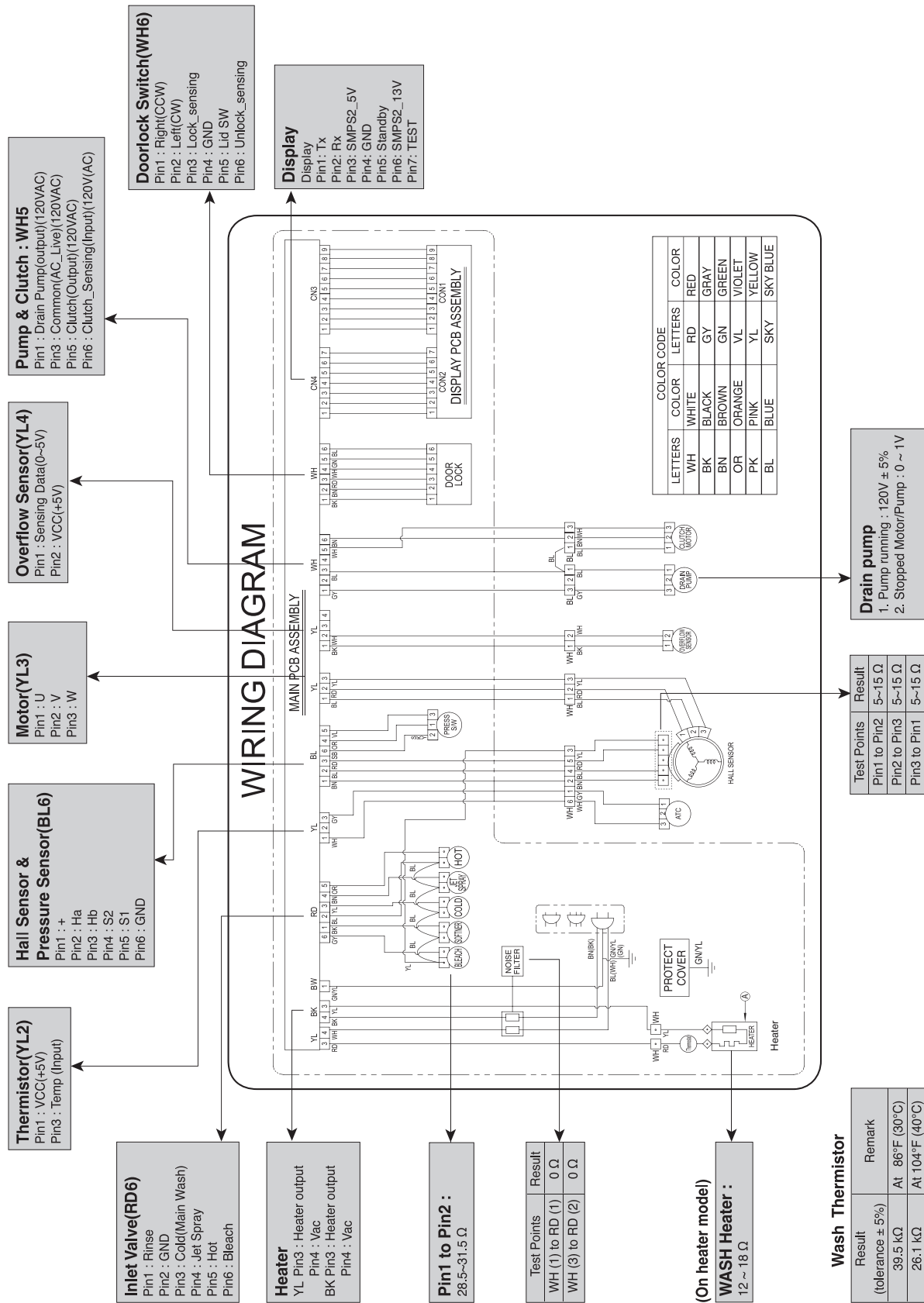

4-6. TROUBLESHOOTING WITH ERROR CODE

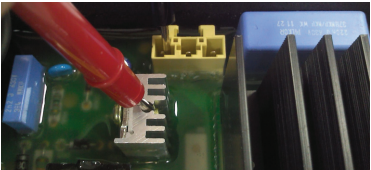
Trouble	Check	counterplan
IE	<ol style="list-style-type: none"> 1. Verify the valve is open and water is on. 2. Check the filter on inlet valve whether clogged with foreign material or not. 3. Check the connector of valve and RD6 on PCBA. 4. Check the testmode (Testmode 3) 5. Check the valve resistance. (0.8-1.2 kΩ) 	<ol style="list-style-type: none"> 1. Turn the tap on. 2. Clean or replace the filter 3. Reconnect or repair the connector 4. Replace the PCBA 5. Replace the inlet valve assembly.
OE	<ol style="list-style-type: none"> 1. Check the test mode (Testmode 6) 2. Check the connector of PCBA or pump or connection connector 3. Check the connection from PCB to pump by tester 4. Check the pump SPEC (resistance of the coil is 10-20 Ω) and input voltage on working (120V±5%) 	<ol style="list-style-type: none"> 1. Replace the PCBA 2. Reconnect or repair the connector 3. Replace harness 4. Replace pump
dE	<ol style="list-style-type: none"> 1. Connect other doorlock switch and check the lid sensing by magnet 	<ol style="list-style-type: none"> 1. Replace the doorlock switch or PCBA
dL	<ol style="list-style-type: none"> 1. Check the doorlock switch trying locking 2. Check the balance of the lid. 	<ol style="list-style-type: none"> 1. If trying, replace the doorlock switch. Or not trying replace the PCBA 2. Replace the door or set the balance
FE	<ol style="list-style-type: none"> 1. Check the Water level <ol style="list-style-type: none"> (1) Power on and run (2) Press the DELAY WASH & EXTRA RINSE 2. Check the valve 	<ol style="list-style-type: none"> 1. If segment is displayed under 10, replace the PCBA 2. Replace the valve
tE	<ol style="list-style-type: none"> 1. Check the connector of PCBA (YL2) or thermistor or connection connector 2. Check the cutted connection from PCB to thermister by tester 	<ol style="list-style-type: none"> 1. Reconnect or repair the connector 2. Replace harness
PE	<ol style="list-style-type: none"> 1. Check the Presure Sensor (21~23 Ω ±10%) and connection 2. Check the Connector (BL6) 	<ol style="list-style-type: none"> 1. Reconnect or repair the connector
LE	<ol style="list-style-type: none"> 1. Check the connector of PCBA (YL3, BL6) or motor connector or connection connector 2. Check the magnet for Rotor 3. Check the Rotor Resistance (YL3) 5 to 15 Ω (U-V, V-W, W-V :U=1, V=2, W=3) 	<ol style="list-style-type: none"> 1. Reconnect or repair the connector 2. Replace the rotor. 3. Replace the stator.
No Power	<ol style="list-style-type: none"> 1. Check the fuse for noise filter and PCBA by tester 2. Check the IPM <ul style="list-style-type: none"> - . Check the Short between top switch Heatsink and YL3 pin by Tester 	<ol style="list-style-type: none"> 1. If the beep sounds, the fuse is OK. If no beep, change the noise filter, including the fuse. 2. If beep sound, replace the PCBA.

DRAIN ERROR

Is OE displayed?

Yes

Is the connector connected to pump motor assembly disconnected or disassembled?



Drain pump

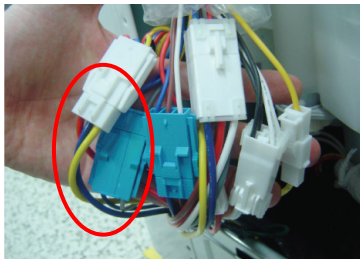

Connection connector

Yes

Reconnect or repair the connector

No

When you enter the SVC Mode, is the water level frequency below 26.0 kHz?

Yes

Check the AIR CHAMBER, the tube (clogged), and press switch



No

Is the coil of the drain pump too high or low? (resistance of the coil is 10-20 Ω)

Yes

Replace the DRAIN PUMP ASSEMBLY.

No

Is the voltage between connectors out of range? (WH6 Pin 1)
- After remove Terminal Position Assurance of connector, check as follows.

Yes

Replace the MAIN PCB ASSEMBLY.

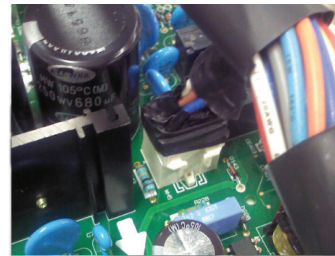

Pump running : 120V±5%
Stopped Motor/Pump : 0~1V
Method

1. Enter the SERVICE Mode.
2. Press START/PAUSE button.
 - : 1 time Main version
 - : 2 times Display version
 - : 3 times Inlet valve check mode
 - : 4 times Cold valve, bleach valve
 - : 5 times Rinse valve, hot valve
 - : 6 times Jet spray valve
 - : 7 times Heater check
 - : 8 times Alph check
 - : 9 times Pump check

[Note] Environmental check list

- 1) The drainage hose must not stay in a lower position
- 2) The drainage hose must not be bent or clogged in any way due to the surrounding physical configuration
- 3) The drainage hose must not get frozen at all times.
- 4) The drainage pump must not have any improper substance or material inside that may cause a machine breakdown.

LOCKED MOTOR ERROR

Is LE displayed?

Yes

Check the connectors below.
Is the connector disconnected or disassembled?

(motor hall sensor connector, motor drive connector)
- Part of main PCB assembly (YL3, BL6)

Yes

Reconnect the connector (connector / wire / motor)

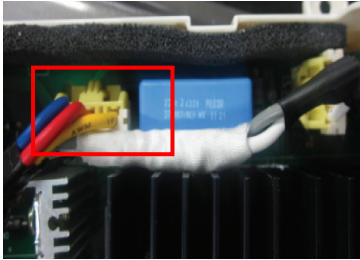

Motor Drive

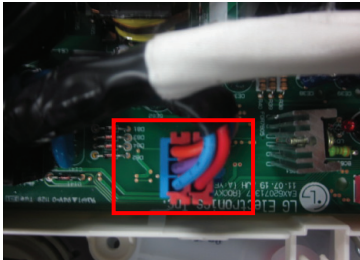

Hall Sensor

- Part of wire

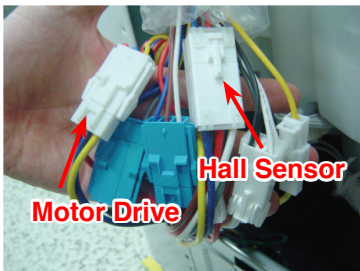

Motor Drive

Hall Sensor

- Part of motor

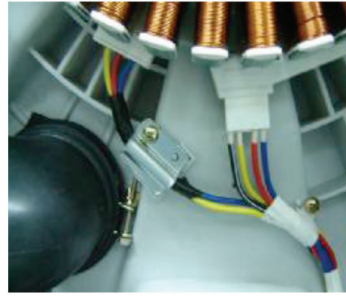

Motor

No

Is rotor magnet cracked?

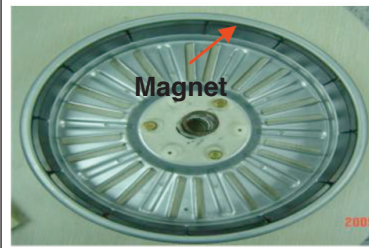

Magnet

Yes

Replace the ROTOR

No

Is the resistance values in the range of 5 to 15 Ω ?
(U-V, V-W, W-V)
:U=1, V=2, W=3)

- After pull out the YL3 connector, check the terminal of the connector in wire.

No

Replace the STATOR

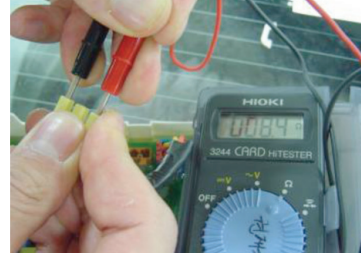

Yes

Is hall sensor out of order ?

Yes

Replace the Hall sensor

No

Check the IPM in the controller. Is IPM short?

Yes

Replace the MAIN PCB ASSEMBLY



UNBALANCE ERROR

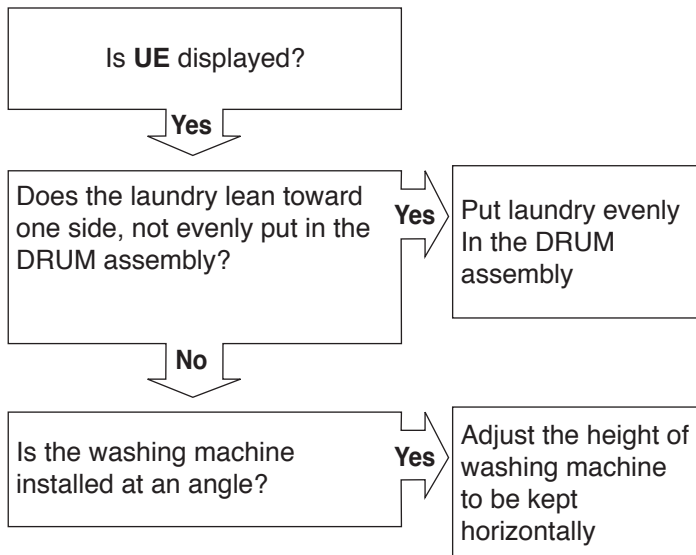

OVER FLOW ERROR

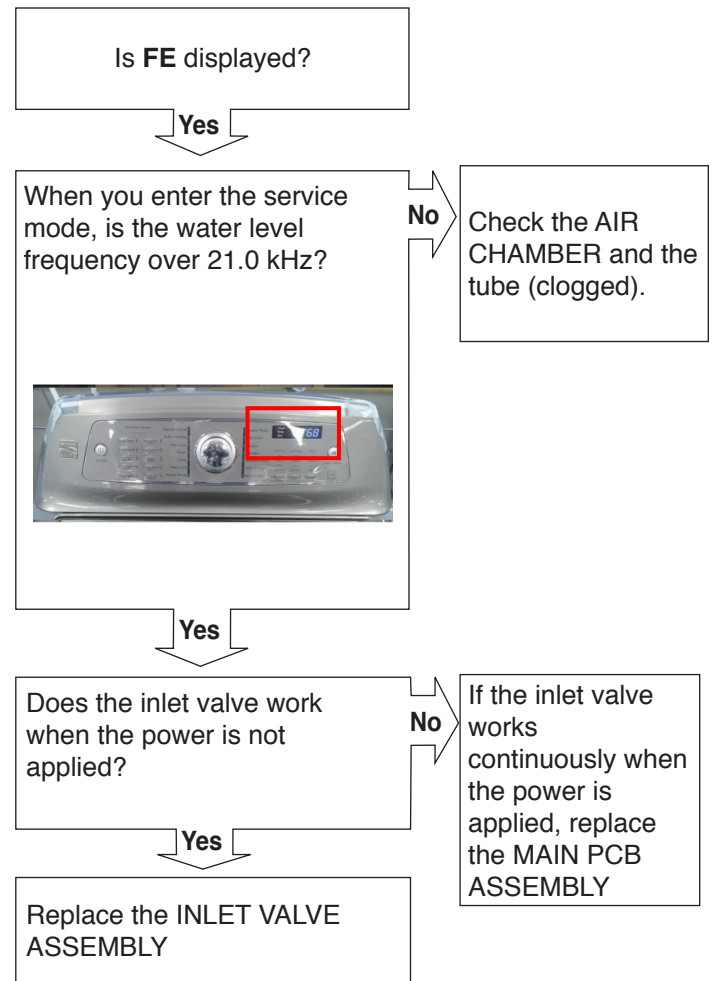

PRESSURE SENSOR ERROR

Is PE displayed?

Yes

Is the connector connected to pressure sensor disconnected or disassembled?

Yes

Reconnect or repair the connector



No

Is the resistance of the pressure sensor out of range? (pin 1~ pin 3)
(21~23 Ω ±10%)

Yes

Replace the pressure switch

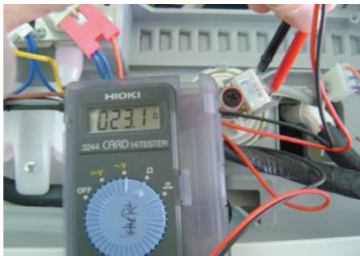

No

Is the AIR CHAMBER and the tube clogged?

Yes

Fix the air chamber and remove the foreign material

No

Replace the MAIN PCB assembly

4-7. OTHER TROUBLESHOOTING

⚠ CAUTION

1. Be careful of electric shock if disconnecting parts while troubleshooting.
2. First of all, check the connection of each electrical terminal with the wiring diagram.
3. If you replace the main PCB assembly, reinsert the connectors correctly.

NO POWER

Is the supplied voltage 120V AC?(+10%, -15%)

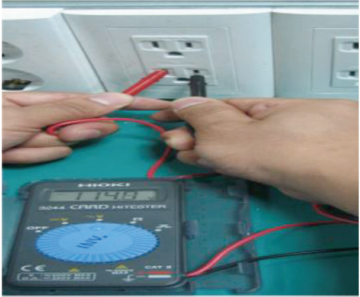

No → Check the fuse or reset the circuit breaker

Is the current rating of multi-outlet power strip enough? (Avoid connecting several electric devices)



No → Alternate with explanation

Is the connector connected to PCB/Noise filter disconnected or disassembled?

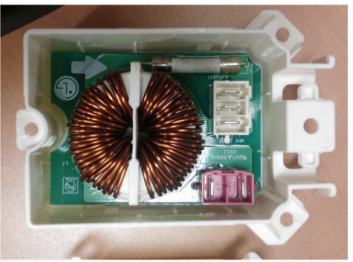

No → Reconnect or repair the connector

Is LED on while the power is on?



Yes → Replace the MAIN PCB ASSEMBLY

Is three pin wire of display PCB broken?

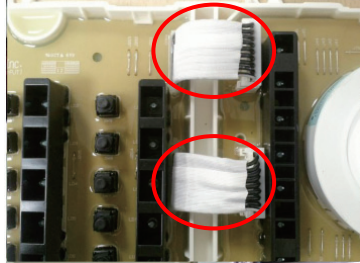

Display PCB

Yes → Replace the DISPLAY PCB ASSEMBLY



Connecting connector MAIN PCB~ Display PCB

POWER BUTTON DOESN'T WORK

Is the connector connected to Main PCB / Display PCB disconnected or disassembled?

Yes

Reconnect or repair the connector

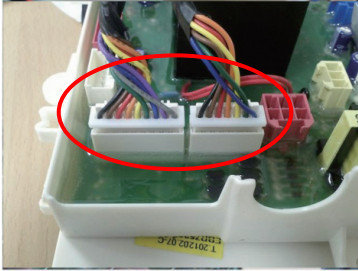

Connecting connector Main PCB~ Display PCB

No

Is the button of panel stuck?

Yes

Repair the button

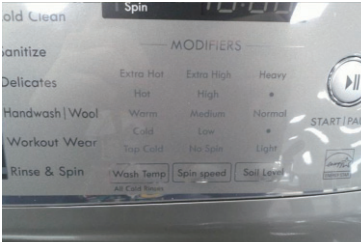

No

Is the display PCB broken? (check the buzzer sound and LED light while touch the LCD)

Yes

Replace the DISPLAY PCB ASSEMBLY



5. COMPONENT TESTING INFORMATION

⚠ WARNING When resistance (Ohm) checking the component, be sure to turn the power off, and do voltage discharge sufficiently.

5-1. FILTER ASSEMBLY (LINE FILTER)

<p>Wiring diagram</p>	<p style="text-align: center;">Circuit in the MAIN PCB / Wiring Diagram</p>						
<p>Test points and Result</p>	<p style="text-align: center;">(2) (1) RD1</p> <table border="1" style="margin-left: auto; margin-right: auto;"> <thead> <tr> <th>Test Points</th> <th>Result</th> </tr> </thead> <tbody> <tr> <td>WH (1) to RD (1)</td> <td>0 Ω</td> </tr> <tr> <td>WH (3) to RD (2)</td> <td>0 Ω</td> </tr> </tbody> </table>	Test Points	Result	WH (1) to RD (1)	0 Ω	WH (3) to RD (2)	0 Ω
Test Points	Result						
WH (1) to RD (1)	0 Ω						
WH (3) to RD (2)	0 Ω						

5-2. DOOR LOCK SWITCH ASSEMBLY

<p>Wiring diagram</p>	<p style="text-align: center;">Circuit in the MAIN PCB / Wiring Diagram</p>
<p>Function</p>	<p>The Door Lock Switch Assembly consists of a DC Motor, a Bimetal, a Protection PTC, Sensing Point. It locks the door during a wash cycle.</p> <p>1. Operation for door closing</p> <ul style="list-style-type: none"> - After the system turns on, the microprocessor sends a motor locking signal. - 12V motor is working. - Spring that connected with motor shaft is working. - The hook that connected with spring is pushed out. - Door lock is detected when switch sensing point is detected lock position. - The motor stops. - Door locked <p>The maximum, allowable number of impulse authorizations is 3</p> <ul style="list-style-type: none"> - Upon the third authorization of the impulse, the position of hook goes back to the door-open position. - Authorizing the impulse occurs in 4.5 seconds upon input for max performance and two authorization processes are allowed at most. <p>2. Operation for door opening</p> <ul style="list-style-type: none"> - With a temporary stop, door automatically opens by hook moving after micom send open signal and the power turns off – maximum of 3 times of the authorizing period - Upon the fourth authorization of the impulse, the position of CAM goes back to the door-close position.

Test points

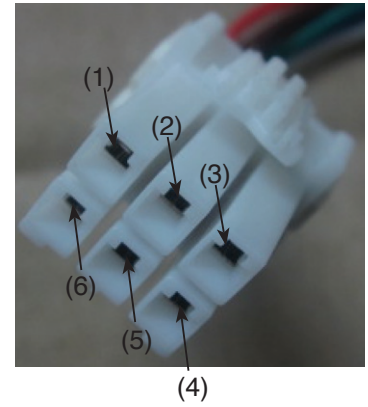

Result

CIRCUIT Diagram

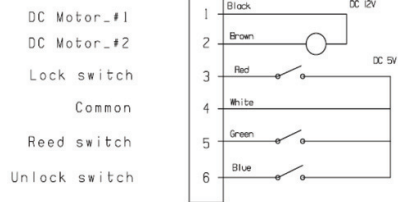

Test Points	Result
(1)To (2) (1)-Black / (2)-Brown	33 ~ 46 Ω
(4) To (5) (4)-White / (5)-Green	9 ~ 11 AT

5-3. STATOR ASSEMBLY

<p>Wiring diagram</p>	<p style="text-align: center;">Circuit in the MAIN PCB / Wiring Diagram</p>								
<p>Function</p>	<p>The DD motor can be driven from stopped to maximum speed in infinite steps in either direction. There are 36 poles on the stator; 12 permanent magnets spaced around the rotor. There are no brushes to wear out. Unlike a more traditional brushless motor, the rotor surrounds the stator rather than being attached to it.</p>								
<p>Test points (Windings)</p>									
<p>Result (Windings)</p>	<table border="1"> <thead> <tr> <th>Test Points</th> <th>Result</th> </tr> </thead> <tbody> <tr> <td>(1) to (2)</td> <td>5-15 Ω</td> </tr> <tr> <td>(2) to (3)</td> <td>5-15 Ω</td> </tr> <tr> <td>(3) to (1)</td> <td>5-15 Ω</td> </tr> </tbody> </table>	Test Points	Result	(1) to (2)	5-15 Ω	(2) to (3)	5-15 Ω	(3) to (1)	5-15 Ω
Test Points	Result								
(1) to (2)	5-15 Ω								
(2) to (3)	5-15 Ω								
(3) to (1)	5-15 Ω								

The hall sensor determines the speed and direction of the motor.
It also can read that the load is off balance when the drum speed fluctuates.

- Voltage Testing Hall Sensor at Stator

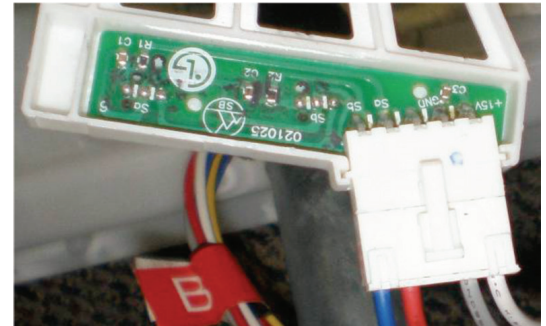
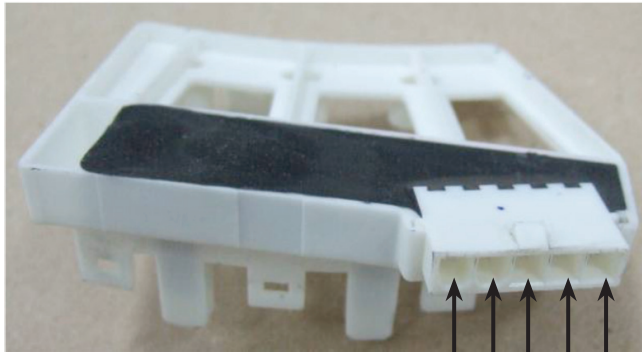

(1) (2) (3) (4) (5)

If measuring voltage from the Main PCB Assembly to the Hall Sensor, use the following steps:

1. Unplug power cord.
2. Remove rear washer panel.
3. Locate Hall sensor connector on the stator behind the rotor.
4. Place meter leads on terminals 5 to 4, white to gray.
5. Plug in power cord, close door, and press power button.
DO NOT PRESS START!
6. You should measure 10 to 15 Vdc. If 10 to 15 Vdc is present, control board, white wire, and gray wire are OK! If not follow testing output voltages on control board in next section.

Test point and Result (Hall Sensor)

Test Points	Result	Remarks
(1) To (4)	3 MΩ ↑	Resistance
(2) To (4)	3 MΩ ↑	Resistance
(1) To (5)	9 kΩ ↑	Resistance
(2) To (5)	9 kΩ ↑	Resistance

7. To measure output signal voltage from the hall sensor, carefully move test leads to terminals 1 to 4, blue and gray. Slowly rotate motor rotor by hand. You should read a pulsing 10 Vdc. If 10 Vdc is measured from 1 to 4, move lead on blue wire to red wire, terminal 2. Repeat rotating motor rotor by hand. You should read a pulsing 10 Vdc from red to gray.
8. If pulsing 10 Vdc is measured from 1 to 4 and 2 to 4, hall sensor is OK! If either test netted only 9 to 10 Vdc without changing (no pulsing) the hall sensor is likely defective. Disconnect power by unplugging washer and ohm check hall sensor to verify failure of the hall sensor.

- Voltage Testing Hall Sensor from the Main PCB Assembly

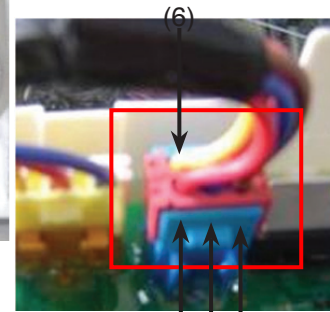

1. Unplug power cord.
2. Remove rear panel.
3. Remove Washer Top.
4. Remove Main PCB Assembly cover as shown in Figure below.
5. Locate the Blue Hall Sensor 6 wire connector using wiring diagram wire colors as your guide.
6. Plug in power cord, close door, and press power button. **DO NOT PRESS START!**
7. Place meter leads on White & Gray wires. You should read 10 to 15 Vdc output from the Main PCB Assembly to the Hall sensor. If no 10 to 15 Vdc is measured the control board is defective.
8. Place meters leads on Blue to Yellow. Turn motor rotor slowly by hand. You should measure a pulsing 10 Vdc. Place meter leads on Red to Yellow. Turn motor rotor slowly by hand. You should measure a pulsing 10 Vdc. If both tests measure a pulsing 10 Vdc, hall sensor and harness OK. If either or both tests measures 9 to 10 volts, but does not pulse or change, Hall sensor has failed and must be replaced. IF zero (0) voltage is measured on either test, check red & blue wires for continuity. Repair or replace harness as needed.

Test point
and
Result (Hall Sensor)

Test Points	Result	Remarks
(1) to (2)	8-12 kΩ	
(1) to (3)	8-12 kΩ	
(1) to (6)	10-15 Vdc	Voltage Input
(2) to (6)	10 Vdc	Pulsing Signal
(3) to (6)	10 Vdc	Pulsing Signal

5-4. PUMP MOTOR ASSEMBLY

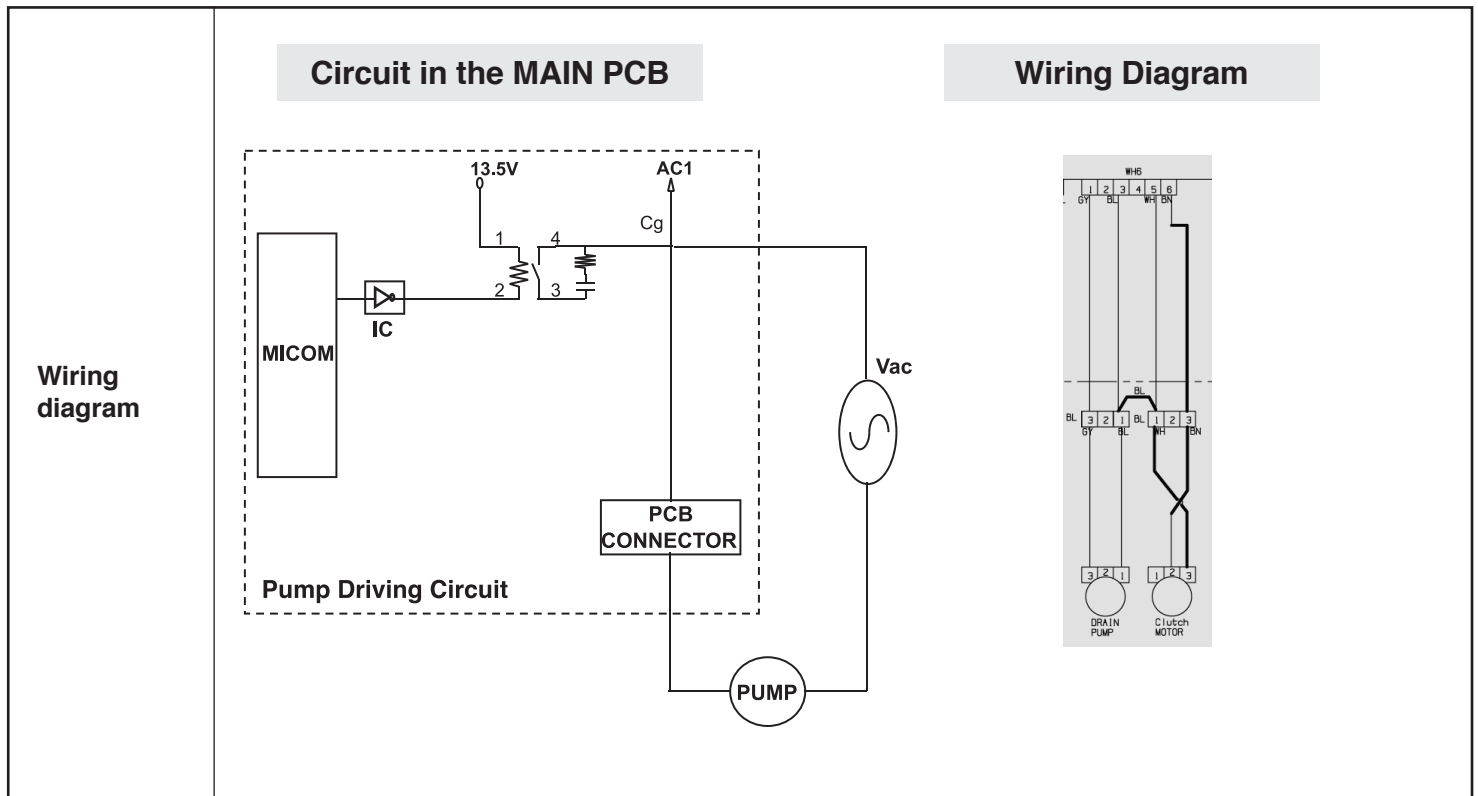

Test points and Result

Test Points	Result	Remarks
(1) to (2)	$10.9 \Omega \pm 5\%$	Resistance

5-5. INLET VALVE ASSEMBLY

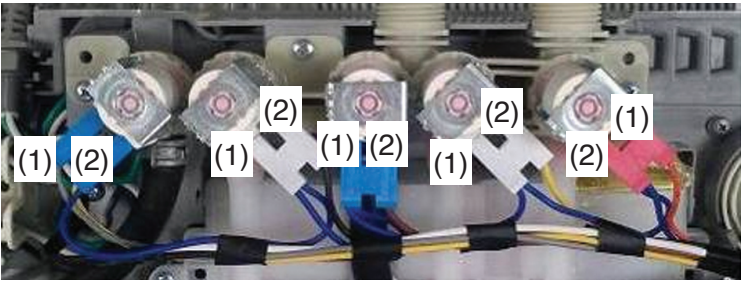
<p>Wiring diagram</p>	<div style="text-align: center;"> <p>Circuit in the MAIN PCB</p> </div> <div style="text-align: center; margin-top: 20px;"> <p>Wiring diagram</p> </div> <p style="text-align: right;">* All valves operate at 13.5 VDC.</p>				
<p>Function</p>	<p>Depending on the cycle and water temperature, the controller will energize the hot or cold water valve solenoids to meet the selected water temperature.</p>				
<p>Test points and Result</p>	<p>After unplugging the connector of the defective valve, check the resistance.</p> <div style="display: flex; align-items: center;">  <table border="1" style="margin-left: 20px;"> <tr> <td>Test Points</td> <td>(1)-(2)</td> </tr> <tr> <td>Result</td> <td>24±10% [Ω]</td> </tr> </table> </div>	Test Points	(1)-(2)	Result	24±10% [Ω]
Test Points	(1)-(2)				
Result	24±10% [Ω]				

5-6. HEATER ASSEMBLY

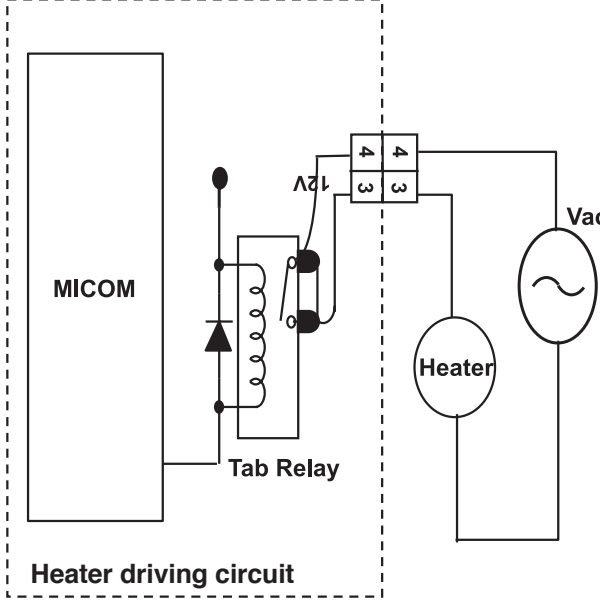
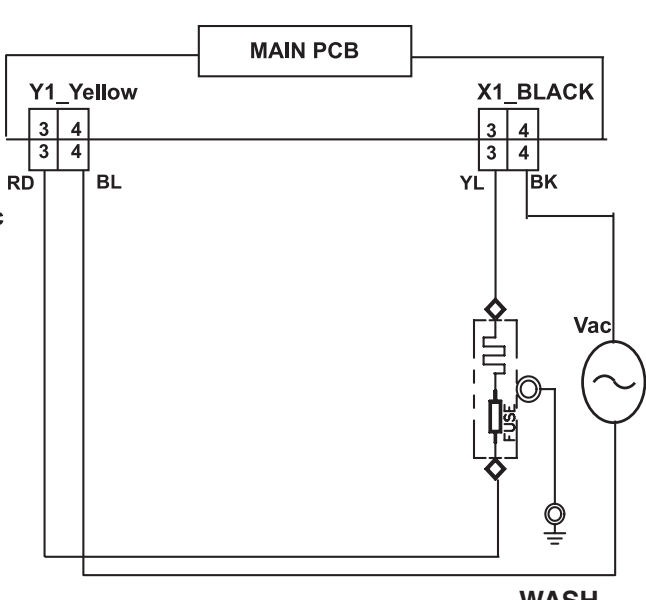
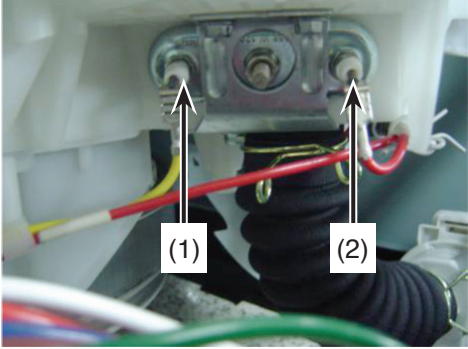
<p>Wiring diagram</p>	<div style="display: flex; justify-content: space-around;"> <div style="border: 1px solid black; padding: 5px; background-color: #f0f0f0; width: 45%;"> <p style="text-align: center;">Circuit in the MAIN PCB</p>  <p style="text-align: center;">Heater driving circuit</p> </div> <div style="border: 1px solid black; padding: 5px; background-color: #f0f0f0; width: 45%;"> <p style="text-align: center;">Wiring diagram</p>  <p style="text-align: center;">WASH HEATER</p> </div> </div>				
<p>Function</p>	<ol style="list-style-type: none"> 1. The wash heater is designed to raise the wash water to the desired temperature selection during certain wash cycles. 2. The steam generator heater is designed to make the water to the steam during steam cycles. 				
<p>Test points</p>	 <p style="text-align: center;">Wash Heater</p>				
<p>Result</p>	<p style="text-align: center;">Wash Heater</p> <table border="1" style="margin-left: auto; margin-right: auto;"> <thead> <tr> <th>Test Points</th> <th>Result</th> </tr> </thead> <tbody> <tr> <td>(1) to (2)</td> <td>12-18 Ω</td> </tr> </tbody> </table>	Test Points	Result	(1) to (2)	12-18 Ω
Test Points	Result				
(1) to (2)	12-18 Ω				

5-7. THERMISTOR ASSEMBLY

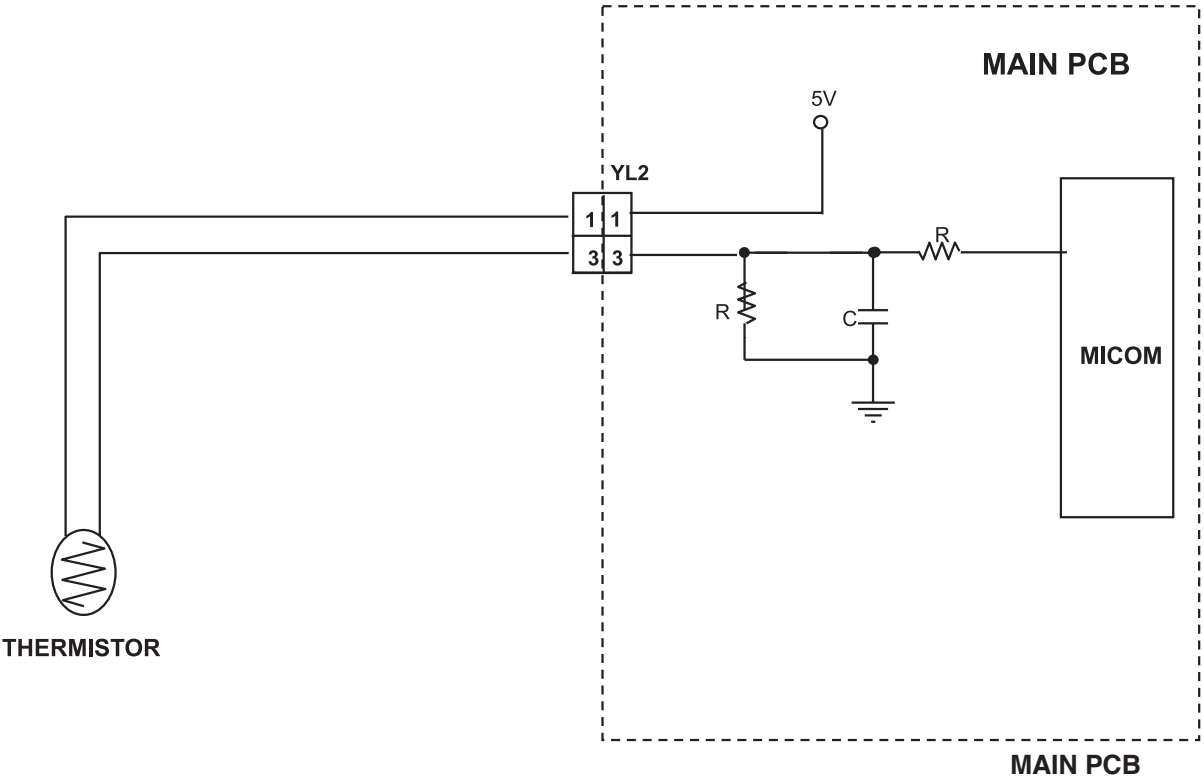
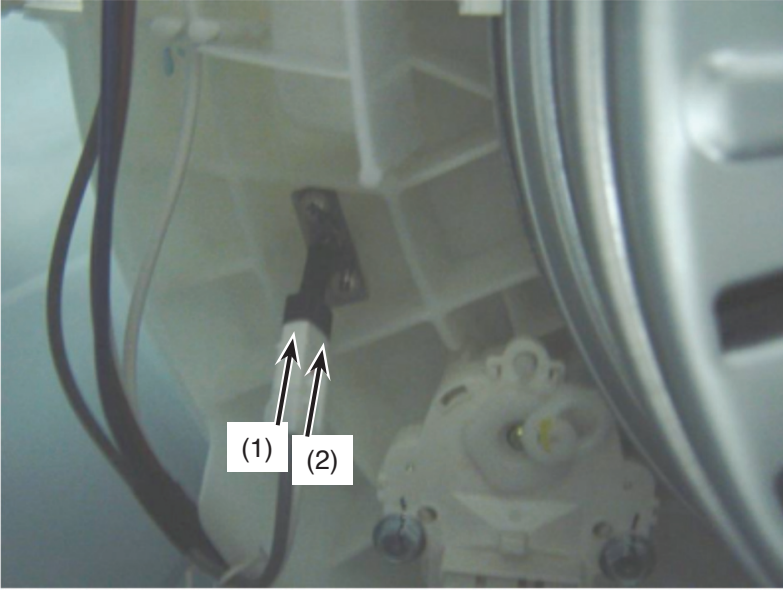
<p>Wiring diagram</p>	<p style="text-align: center;">Circuit in the MAIN PCB / Wiring Diagram</p>  <p>The diagram illustrates the electrical connection for the thermistor. On the left, a thermistor symbol is labeled "THERMISTOR". It is connected to terminal 1 of a two-pin connector labeled "YL2". Terminal 3 of the YL2 connector is connected to a 5V power source. A resistor (R) is connected between terminal 3 and the thermistor. A parallel combination of a resistor (R) and a capacitor (C) is connected between the 5V supply and ground. The thermistor is also connected to a MICOM component through another resistor (R). The entire circuit is enclosed in a dashed box labeled "MAIN PCB".</p>
<p>Function</p>	<p>The thermistor (temperature sensor) is used to monitor water temperature in the tub.</p>
<p>Test points</p>	 <p style="text-align: center;">Wash Thermistor</p>

Result	Wash Thermistor				
	Test Points	Result [$k\Omega$]			Remarks
		The lowest limit	standard	The upper limit	
	(1) to (2)	70.519	76.531	82.848	At 86°F (30°C)
		46.997	50.584	54.307	At 104°F (40°C)
		22.285	23.623	24.978	At 140°F (60°C)
		15.803	16.635	17.467	At 158°F (70°C)
6.984		7.471	7.971	At 203°F (95°C)	
5.180		5.573	5.981	At 221°F (105°C)	

6. EXPLODED VIEW

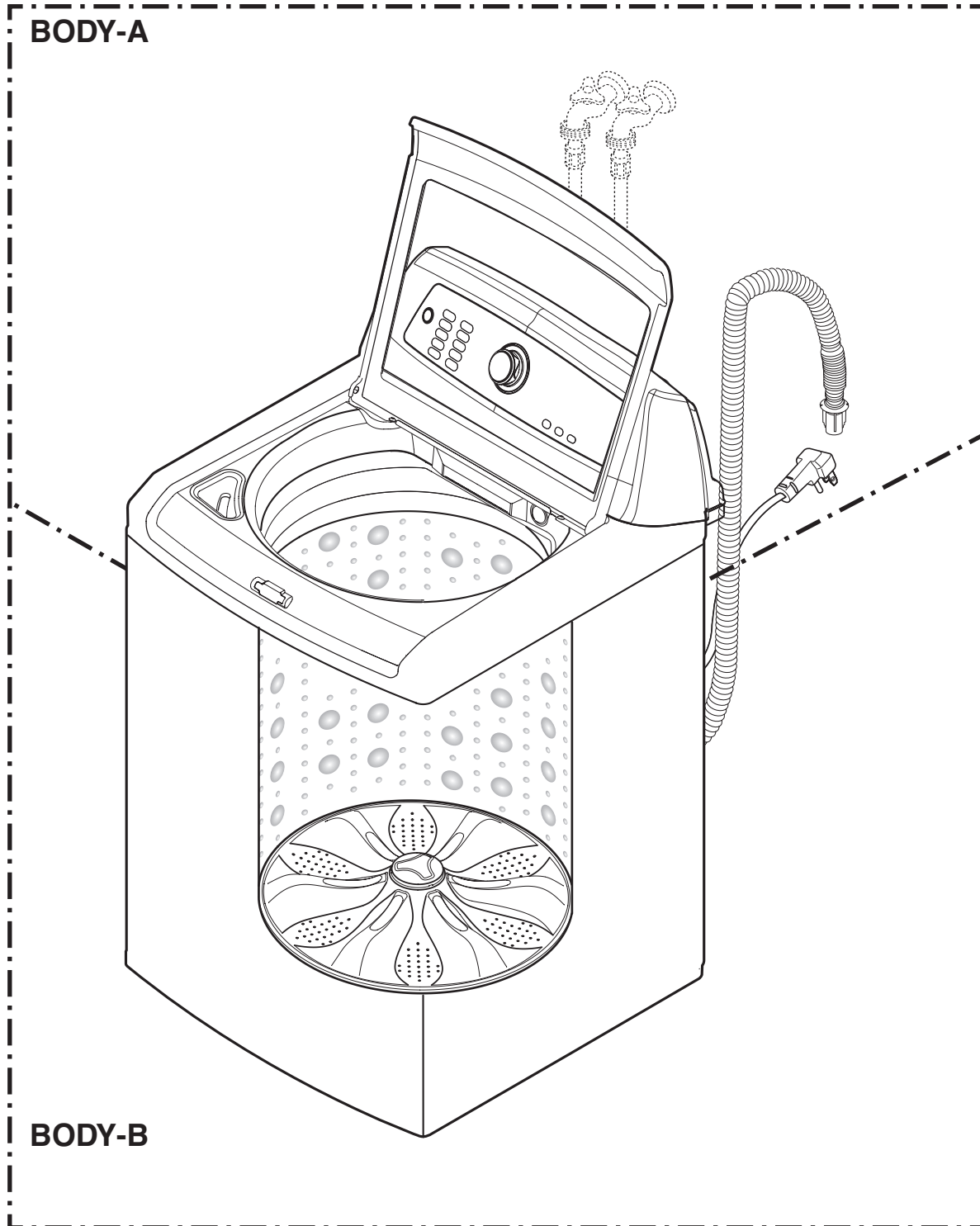

5-1. EXPLODED VIEW OF TOP COVER ASSEMBLY

LY

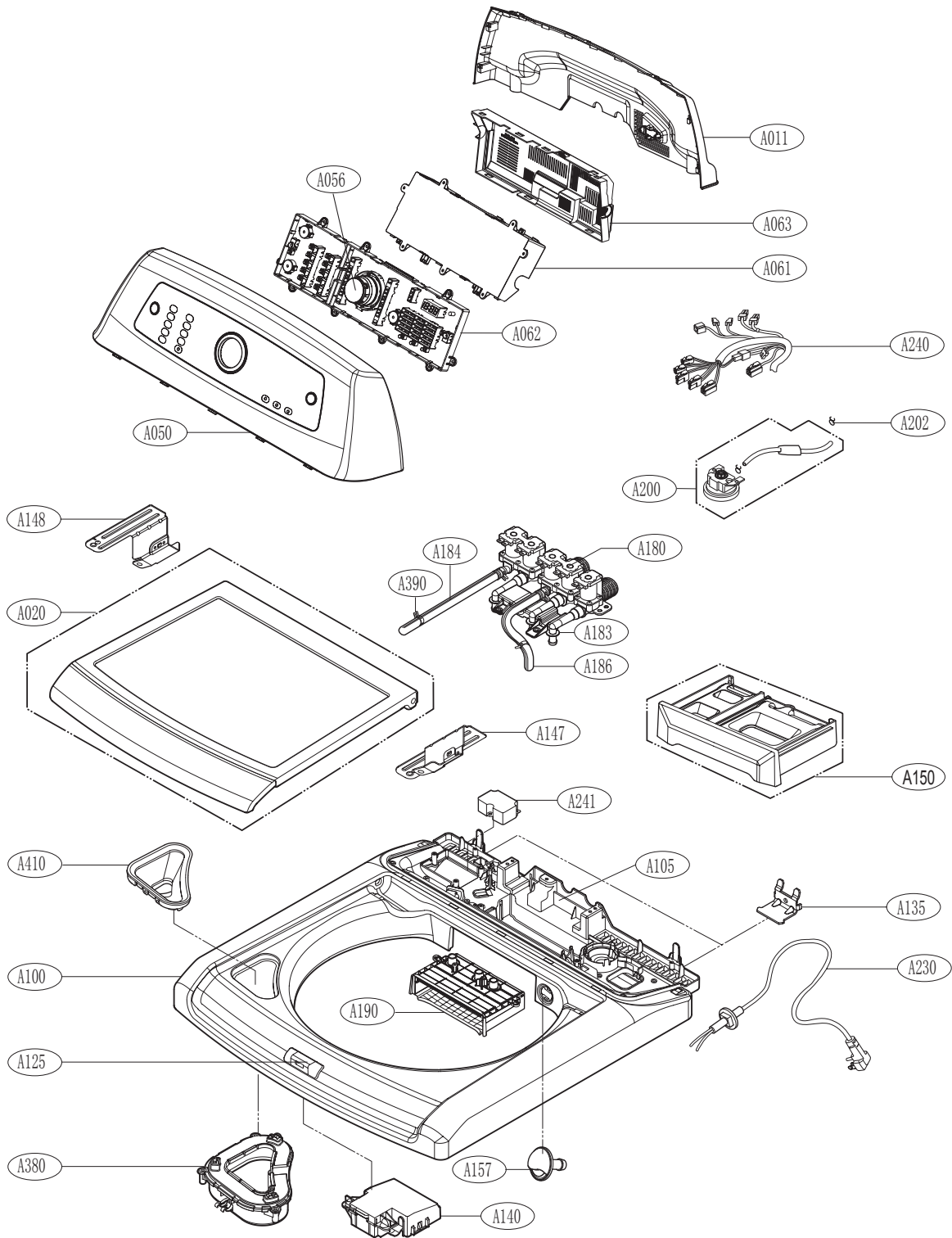

5-2. EXPLODED VIEW OF OUT CASE ASSEMB

LY

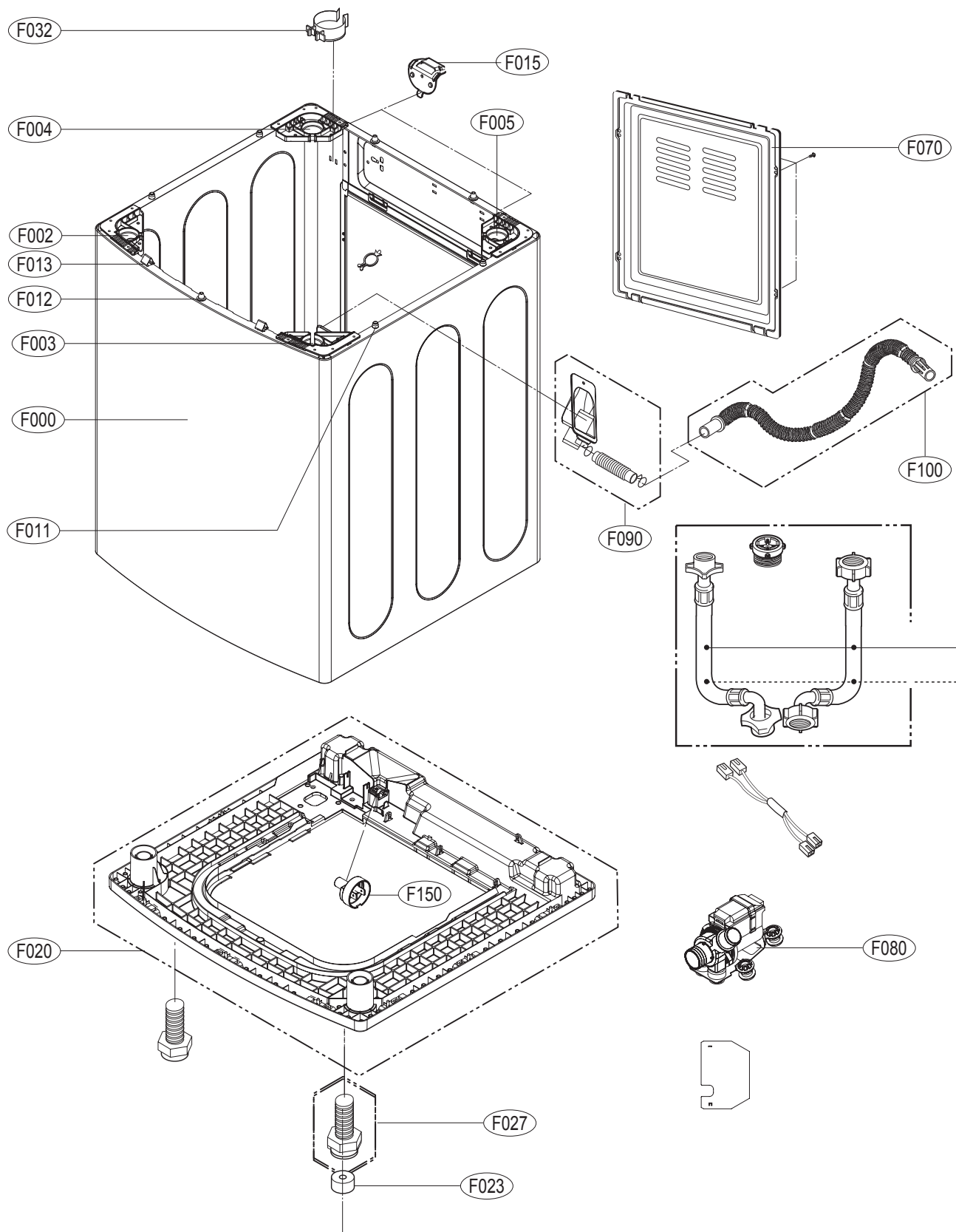

5-3. EXPLODED VIEW OF TUB ASSEMBLY

LY

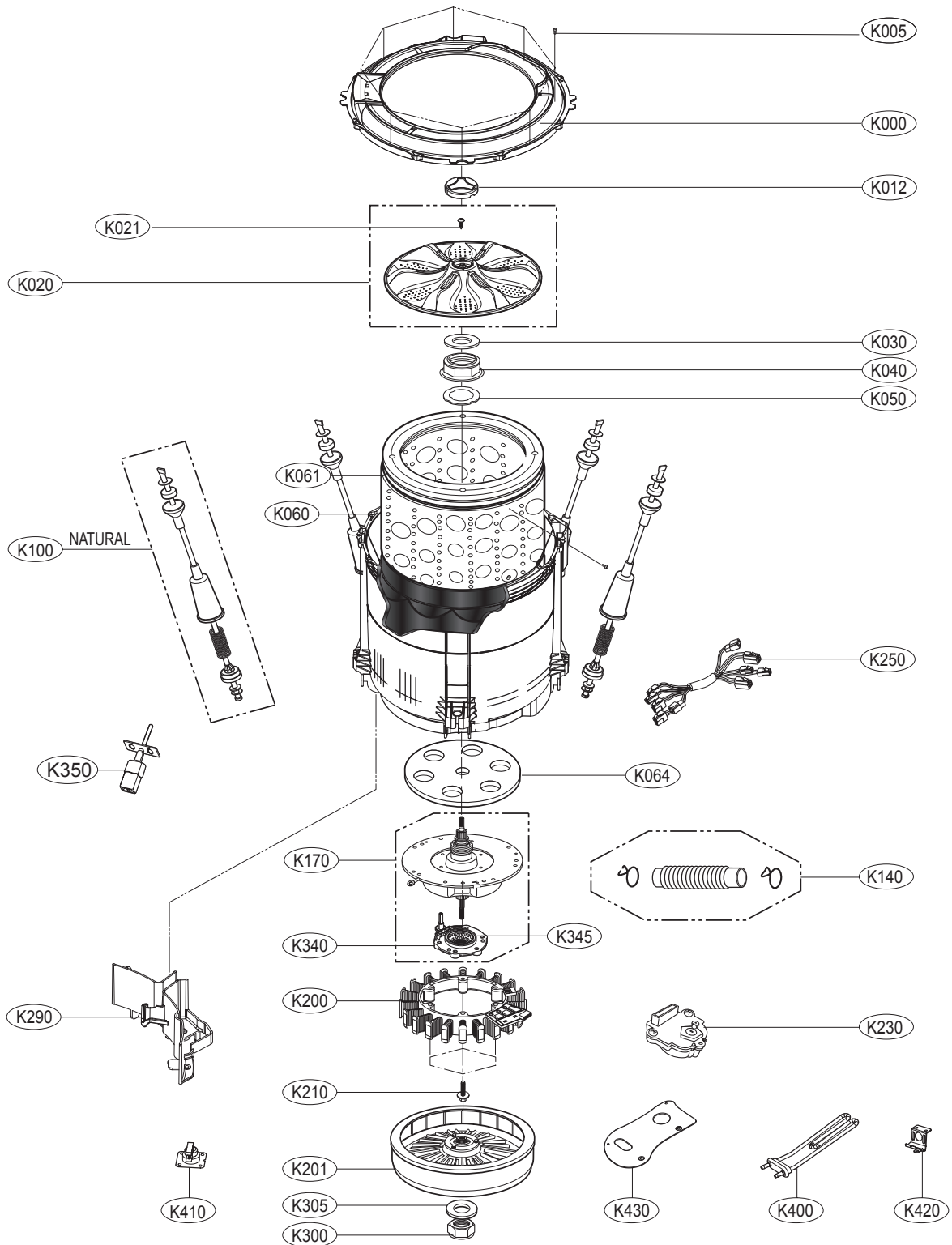

7. REPLACEMENT PART LIST



P/No.: MFL40322150