

LG TRAINING MANUAL

Steam Washer WM0742H*A

Fall 2008

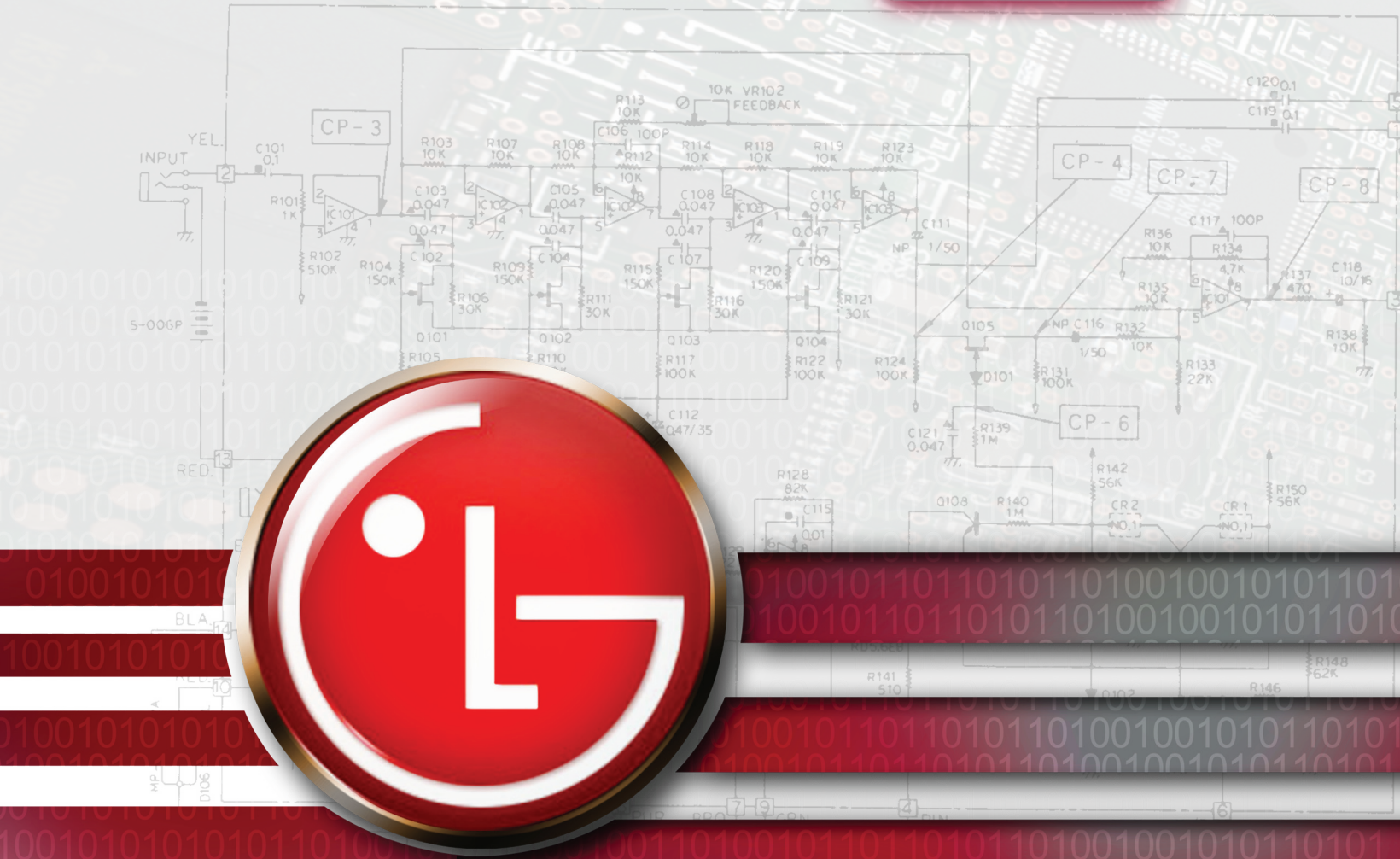

Published August 2008 by LG Electronics USA Training Center
Copyright © 2008 LG Electronics of Alabama, Inc.

PHONE CONTACTS:

Contact	Number	Hours of Operation
Customer Service	(800) 243-0000	24/7 - 365 days a year
Technical Support	(800) 847-7597	7am-7pm Mon-Fri / Sat 8-2 CST
Parts Sales	(888) 393-6484	7am-7pm Mon-Sat CST
Training Center	(256) 774-4051	8am-5pm Mon-Fri CST

WEB CONTACTS:

Web Site	Address	Description
LG USA	www.lgusa.com	USA sales site
Customer Service	us.lgservice.com	Customer support
GCSC	aic.lgservice.com	Service center support
Customer Service Academy	www.LGCSAcademy.com	Technical training

IMPORTANT SAFETY NOTICE

The information in this training manual is intended for use by persons possessing an adequate background in electrical equipment, electronic devices, and mechanical systems. In any attempt to repair a major appliance, personal injury and property damage can result. The manufacturer or seller maintains no liability for the interpretation of this information, nor can it assume any liability in conjunction with its use. When servicing this product, under no circumstances should the original design be modified or altered without permission from LG Electronics. Unauthorized modifications will not only void the warranty, but may lead to property damage or user injury. If wires, screws, clips, straps, nuts, or washers used to complete a ground path are removed for service, they must be returned to their original positions and properly fastened.

CAUTION

To avoid personal injury, disconnect the power before servicing this product. If electrical power is required for diagnosis or test purposes, disconnect the power immediately after performing the necessary checks. Also be aware that many household appliances present a weight hazard. At least two people should be involved in the installation or servicing of such devices. Failure to consider the weight of an appliance could result in physical injury.

ESD NOTICE

Some of the electronic components in appliances are electrostatic discharge (ESD) sensitive. ESD can weaken or damage the electronics in these appliances in a manner that renders them inoperative or reduces the time until their next failure. Connect an ESD wrist strap to a ground connection point or unpainted metal in the appliance. Alternatively, you can touch your finger repeatedly to a ground connection point or unpainted metal in the appliance. Before removing a replacement part from its package, touch the anti-static bag to a ground connection point or unpainted metal in the appliance. Handle the electronic control assembly by its edges only. When repackaging a failed electronic control assembly in an anti-static bag, observe these same precautions.

REGULATORY INFORMATION

This equipment has been tested and found to comply with the limits for a Class B digital device, pursuant to Part 15 of the FCC Rules. These limits are designed to provide reasonable protection against harmful interference when the equipment is operated in a residential installation. This equipment generates, uses, and can radiate radio frequency energy, and, if not installed and used in accordance with the instruction manual, may cause harmful interference to radio communications. However, there is no guarantee that interference will not occur in a particular installation. If this equipment does cause harmful interference to radio or television reception, which can be determined by turning the equipment off and on, the user is encouraged to try to correct the interference by one or more of the following measures: Reorient or relocate the receiving antenna; Increase the separation between the equipment and the receiver; Connect the equipment to an outlet on a different circuit than that to which the receiver is connected; or consult the dealer or an experienced radio/TV technician for help.

DISCLAIMER

The information in this training manual was accurate at the time of publication. Every effort has been made to ensure accuracy. Updates, changes, etc. are available via GCSC and LGCSacademy. The information in this manual is intended for persons with adequate backgrounds in electronics, mechanical, and electronic servicing. The manufacturer and seller are not to be held responsible for any liability incurred from its use.

COMPLIANCE

The responsible party for this device's compliance is LG Electronics Alabama, Inc.; 201 James Record Road, Huntsville, AL, 35813.

WM0742HGA

SAFETY NOTICES (The Small Print Page)	1
Contents	2
Specifications	4
Warranty	5
Features	6
Controls	7
Fuzzy Logic	8
Door Lock and Indicator Lamp	8
Load Sensing Function	9
Water Circulation	10
Parts Identification (Callout)	11
Accessories	12
Installation	13
Shipping Bolts	13
Leveling Feet	13
Connections	14
Water	14
Drain	14
Electrical	14
Pedestal Installation	15
Control Panel	17
Program Chart	18
Service Safety Warnings	18
Cycle and Option Chart	19
Cycle and Option Information	20
Water Temperature Control	25
Wiring Diagram	27
Dispenser	28
Dispenser Hose Connection Chart	30
Direct Drive Motor	31
Disassembly and Repair	32
Block Wiring Diagram	32
Control Panel	33
Top Cover	33
Dispenser	34
Noise Filter (Electronic)	34
Front Cover	35
Door and Hinge	36
Pumps and Filter Housing	37
Wash Heater	38
Foreign Object Removal	38
Water Level Switch	39
Motor	40

Disassembly and Repair, continued	
Tub and Drum	41
Dampers	42
Turbo Steam Generator	43
Removal / Replacement	43
Input Check Valve	44
Water Level Sensor Wiring Diagram	45
Low Water Sensor	46
High Water Sensor	46
Hall Sensor Test, Diagnosis, and Repair	48
Hall Sensor Wiring Diagram	48
Hall Sensor Testing	50
Voltage Testing Hall Sensor at Stator	50
Control Board Testing Location	51
Voltage Testing Hall Sensor at Control Board	52
Test Mode	53
Error Display	54
Error Code Chart	54
Diagnosis and Check List	56
No Power, No Water Input (IE)	56
Door Error (dE), Drain Trouble (OE)	57
Oversudsing, No Softening, Error Codes (PE , FE , tE , and LE)	58
Fault Diagnosis and Troubleshooting	59
No Power	59
Vibration and Noise In Spin Cycle	60
No Water Supply	61
Detergent Fails To Dispense	61
Liquid Detergent / Bleach / Softener Fail To Dispense	62
Heating Without Water	63
Drain Malfunction	63
Wash Heater Malfunction	64
Wash Heater Overrun	64
Circulation Failure	65
Spin (Motor) Malfunction	66
dE Error Code	66
Tips and Tricks	67
Main Board, With Connectors Labeled	68
Exploded Views	69
Parts List	72
Special Tools, With Part Numbers and Photos	75
Serial Number Identification	76
Supplementary Material	77
Service Bulletins	79
Process Technical Information	89

INTRODUCTION

The WM0742HGA is a top-of-the-line front-loader with the optional cycles of Allergiene™, Steam, and Tub Clean.

SPECIFICATIONS

ITEM		WM0742H+A
COLOR		W:BLUE WHITE, G:PEARLY GRAY
POWER SUPPLY		AC 120 V, 60 Hz
PRODUCT WEIGHT		192 lbs (87kg)
ELECTRICITY CONSUMPTION	WASHING	280 W
	DRAIN MOTOR	80 W
	WASH HEATER	1000 W
REVOLUTION SPEED	WASH	46 rpm
	SPIN	0-1150 rpm
Cycles		9
WASH/RINSE TEMPERATURES		5
SPIN SPEEDS		5
OPTIONS		PRE-WASH, STAIN CYCLE, STEAM, EXTRA RINSE, RINSE+SPIN, DELAY WASH
WATER CIRCULATION		Incorporated
OPERATION WATER PRESSURE		14.5-116 psi (100-800 kPa)
CONTROL TYPE		Electronic
WASH CAPACITY [cu.ft]		3.63 (4.2 IEC)
DIMENSIONS		27" (W) X 29 3/4" (D) X 38 11/16" (H), 50 13/16" (D, door open)
DELAY WASH		up to 19 hours
DOOR SWITCH TYPE		PTC + Solenoid
WATER LEVEL		10 steps (by sensor)
LAUNDRY LOAD SENSING		Incorporated
ERROR DIAGNOSIS		Incorporated
AUTO POWER OFF		Incorporated
CHILD LOCK		Incorporated
RLM ENABLE		-
STEAM		Incorporated

WARRANTY

Warranty statements vary by product. Be sure to check the warranty that was included with the product because that is the valid warranty. This statement is generic and for instructional purposes only.

**LG ELECTRONICS, INC.
LG LIMITED WARRANTY - USA**



Your LG Product will be repaired or replaced, at LG's option, if it proves to be defective in material or workmanship under normal use, during the warranty period ("Warranty Period") set forth below, effective from the date ("Date of Purchase") of original consumer purchase of the product. This warranty is good only to the original purchaser of the product and effective only when used in the United States, including Alaska, Hawaii, and U.S. Territories.

<p>WARRANTY PERIOD:</p> <p>LABOR: See Owner's Manual with product</p> <p>PARTS (except as listed below): See Owner's Manual</p> <p style="padding-left: 40px;">Electronic Control Board: See Owner's Manual</p> <p style="padding-left: 40px;">Drum Motor: See Owner's Manual with product</p> <p style="padding-left: 20px;">Replacement Units and Repair Parts may be new or remanufactured.</p> <p style="padding-left: 20px;">Replacement Units and Repair Parts are warranted for the remaining portion of the original unit's warranty period.</p>	<p>HOW SERVICE IS HANDLED:</p> <p>In-Home Service:</p> <p>Please retain dealer's dated bill of sale or delivery ticket as evidence of the Date of Purchase for proof of warranty, and submit a copy of the bill of sale to the service person at the time warranty service is provided.</p> <p>Please call 1-800-243-0000 and choose the appropriate option to locate your nearest LG Authorized Service Center.</p> <p>Or visit our Web site at: http://www.lgservice.com.</p>
---------------------------------------------------------------------------------------------------------------------------------------------------------------------------------------------------------------------------------------------------------------------------------------------------------------------------------------------------------------------------------------------------------------------------------------------------------------------------------------------------------------------------------------------------------------------------------------------	---------------------------------------------------------------------------------------------------------------------------------------------------------------------------------------------------------------------------------------------------------------------------------------------------------------------------------------------------------------------------------------------------------------------------------------------------------------------------------------------------------------------------------------------

THIS WARRANTY IS IN LIEU OF ANY OTHER WARRANTY, EXPRESS OR IMPLIED, INCLUDING WITHOUT LIMITATION, ANY WARRANTY OF MERCHANTABILITY OR FITNESS FOR A PARTICULAR PURPOSE. TO THE EXTENT ANY IMPLIED WARRANTY IS REQUIRED BY LAW, IT IS LIMITED IN DURATION TO THE EXPRESS WARRANTY PERIOD ABOVE. NEITHER THE MANUFACTURER NOR ITS U.S. DISTRIBUTOR SHALL BE LIABLE FOR ANY INCIDENTAL, CONSEQUENTIAL, INDIRECT, SPECIAL, OR PUNITIVE DAMAGES OF ANY NATURE, INCLUDING WITHOUT LIMITATION, LOST REVENUES OR PROFITS, OR ANY OTHER DAMAGE WHETHER BASED IN CONTRACT, TORT, OR OTHERWISE. Some states do not allow the exclusion or limitation of incidental or consequential damages or limitations on how long an implied warranty lasts, so the above exclusion or limitation may not apply to you. This warranty gives you specific legal rights and you may also have other rights that vary from state to state.

THIS LIMITED WARRANTY DOES NOT APPLY TO:

- Service trips to your home to deliver, pick up, and/or install the product, instruct, or replace house fuses or correct wiring, or correction of unauthorized repairs.
- Damages or operating problems that result from misuse, abuse, operation outside environmental specifications or contrary to the requirements of precautions in the Operating Guide, accident, vermin, fire, flood, improper installation, acts of God, unauthorized modification or alteration, incorrect electrical current or voltage, or commercial use, or use for other than intended purpose.

The cost of repair or replacement under these excluded circumstances shall be borne by the consumer.

CUSTOMER INTERACTIVE CENTER NUMBERS

<p>To obtain Customer Assistance, Product Information, or Dealer or Authorized Service Center location:</p>	<p>Call 1-800-243-0000 (24 hours a day, 365 days a year), and select the appropriate option from the menu.</p> <p>Or visit our Web site at: http://www.lgservice.com.</p>
--------------------------------------------------------------------------------------------------------------------	--------------------------------------------------------------------------------------------------------------------------------------------------------------------------------------------------------------------------------

TO CONTACT LG ELECTRONICS BY MAIL:

LG Customer Interactive Center
P. O. Box 240007
201 James Record Road
Huntsville, Alabama 35824
ATTN: CIC

FEATURES



LARGE CAPACITY

The larger drum (4.2 cu. ft. IEC) allows higher head drop, greater centrifugal force, and washing of larger and heavier loads and oversized items (comforters, curtains, blankets, etc.) There is less wrinkling and tangling of the laundry. (See BULKY / LARGE, page 21.)



DIRECT DRIVE

The brushless DC motor drives the drum directly without belts, pulleys, or transmissions. The maximum spin speed of 1,150 RPM extracts more water from the laundry, reducing drying times.



TILTED DRUM / LARGE DOOR

The tilted drum (10°) and large door opening allow easier loading and unloading.

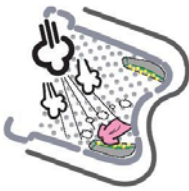

STEAM WASHING / STEAMFRESH®

The steam feature works with the recirculating pump to increase washing performance while maintaining low energy and water usage. STEAMFRESH® is not a wash cycle but uses steam to remove wrinkles from previously laundered dry clothes.

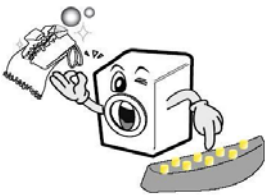

ROLLER JETS and BALLS

The baffles pick up water as the drum turns and allow it to pour through the clothing as it tumbles. The rollers enhance the washing performance while maintaining fabric care.



AUTOMATIC LOAD DETECTION

The microprocessor reads the current required to rotate and stop the drum in order to determine the weight of the load. See additional information on page 9.

FEATURES, continued

BUILT-IN HEATER



The internal heater helps maintain the water at its optimal temperature for selected cycles. The SANITARY cycle kills most common germs and bacteria. The ALLERGIENE cycle is not quite as hot but kills most dust mites and other allergens in laundry. (See additional information on page 39.)



CHILD LOCK

This allows the user to lock the controls. Children then cannot play with the buttons and disturb the wash cycle. (See additional information on page 23.)

CONTROLS

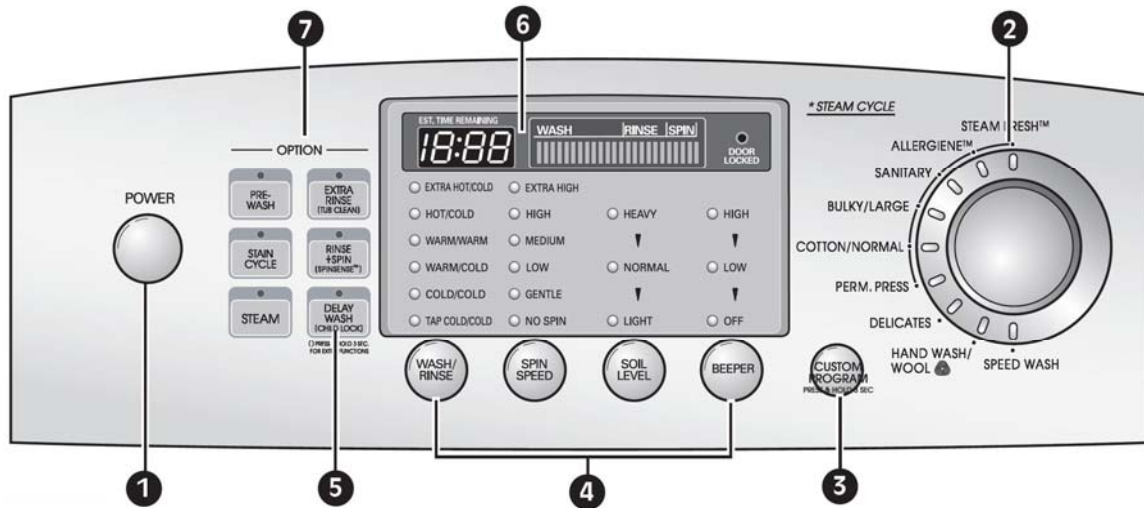

- | | |
|-------------------------------------------------------------------------------------------------------------------------------------------------------------------------------------------------------------------------------------------------------------|---------------------------------------------------------------------------------------------------------------------------------------------------------------------------------------------------------------------------------------------------------------------------------------------------------------------------------------------------|
| <ol style="list-style-type: none"> 1. Power Button 2. Cycle/Start Button 3. Custom Program Button 4. Setting Override Buttons 5. Delay Wash Button 6. Display Window 7. Option Buttons | <p>Turns the machine on or off.</p> <p>Starts or pauses the machine.</p> <p>Sets an often-used program for convenience.</p> <p>Overrides the standard settings for a cycle.</p> <p>Sets the delay to have the washer run later.</p> <p>Shows the estimated remaining time on the cycle.</p> <p>Enables various optional cycles when required.</p> |
|-------------------------------------------------------------------------------------------------------------------------------------------------------------------------------------------------------------------------------------------------------------|---------------------------------------------------------------------------------------------------------------------------------------------------------------------------------------------------------------------------------------------------------------------------------------------------------------------------------------------------|

See additional information on pages 20 ~ 24 in this training manual.

FUZZY LOGIC

To get the best washing performance, the user selects one of the standard cycles. Sensors in the WASHER make an infinitely variable number of adjustments as the cycle progresses. Adjustments are automatically made for load size, incoming water temperature, soil level, rinses required, and other variables.

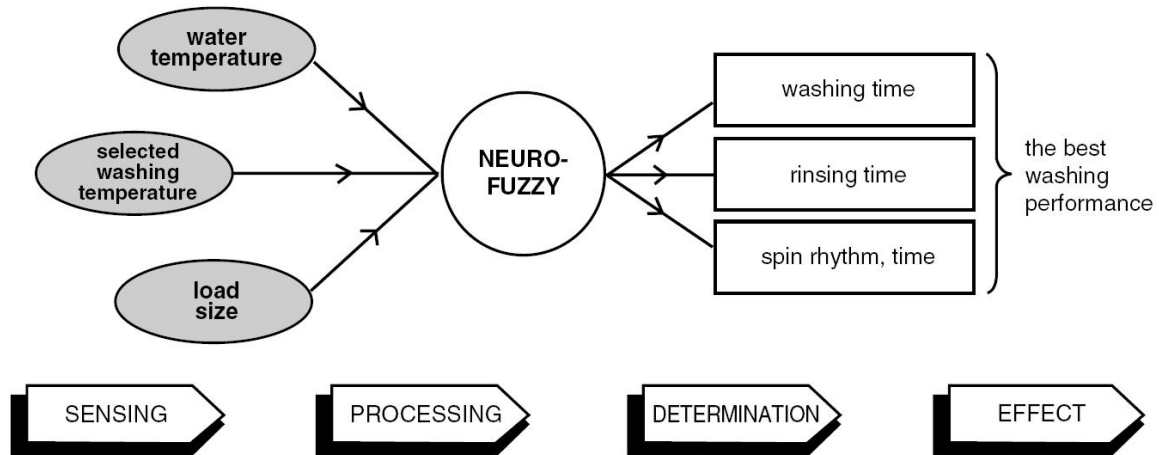

DOOR LOCK

The door has an automatic, electrically operated lock system. When the machine is off or paused, the door can be opened by pulling it. When the machine is operating, the electric latch keeps the door closed.

The door cannot be opened:

- When the WASHER is operating
- When the power failed or the washer is unplugged (until the capacitor discharges and releases the lock)
- When the DOOR LOCK light is on
- When the drum is still turning

DOOR LOCKED LAMP

The DOOR LOCK lamp lights:

- When the WASHER is operating
- When the water level sensor frequency is lower than 22.9 kHz
- When the temperature inside the tub is over 45° C (113°F)

LOAD SENSING FUNCTION

In order to determine the size and weight of the load, the machine begins each cycle by tumbling the load a couple of times. It spins up to approximately 120 rpm for approximately 6 seconds. (Speed and time may vary by model.)

Drum Tumbling



Laundry loaded
Power ON
Machine tumbles



Reaching RPM

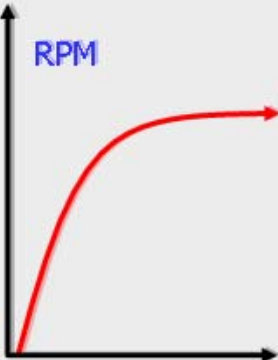

Drum spins up to a specified RPM (speed varies by model)



Braking



Drum is forcibly braked after a few seconds of tumbling



Sensing



Controller senses load size from spin up and spin down. (Spin up speed varies by model)

Determining the size and weight of the load allows the controller to estimate the amount of water required to wash and rinse the load. The fuzzy logic within the program will make numerous decisions during the cycle, adding water, desudsing, and rinsing as determined necessary.

WATER CIRCULATION

The recirculation pump circulates the water during most of the cycle. During the WASH cycle, it runs continuously for the first 3 minutes and then intermittently throughout the cycle. During the RINSE cycle, it runs continuously as soon as the appropriate amount of rinse water has been added. This recirculated water enters the drum at the top of the door at a small shower head. This spray not only keeps the window and gasket clean, it allows the clothes to be soaked with detergent or rinse water more quickly and can be used to control an oversudsing event.

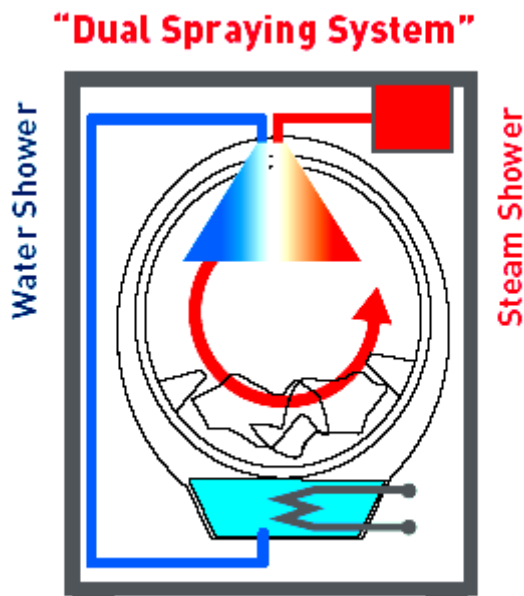

The recirculation pump is separate from the drain pump, but they are attached to opposite sides of the filter housing.

The steam is not pumped; it comes into the washer drum under its own pressure. When steam or the sanitary cycle is used, the door will remain locked until the laundry has cooled to a safe temperature.

The pumps and filter are located at the bottom left front corner. The filter can be unscrewed, cleaned, and replaced.



Use the small drain hose to evacuate the water remaining in the bottom of the tub before removing the filter.

The drain pump is on the left and exhausts the water via the gray corrugated hose.

The recirculating pump is on the right and recirculates water from the tub to the shower spray at the top of the door gasket via the smaller black hose.

The filter is not a lint filter in the usual sense of the word. Its function is to keep debris out of the pump impellers.

PARTS IDENTIFICATION

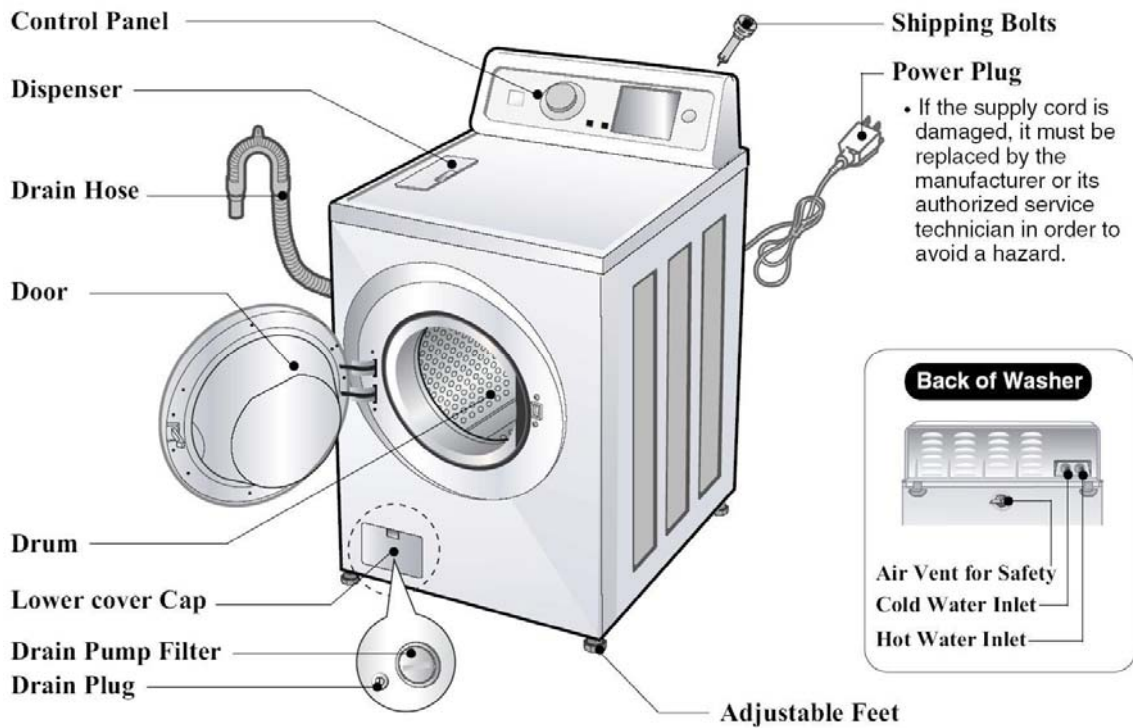

The air vent on the back of the machine must be left open and clear at all times.

If the washer and dryer are installed in a closet or closed laundry alcove, there must be sufficient clearance and ventilation. The closet should have a full louvered door with at least 800 square inches (0.5 m²) of open area for ventilation.

The washer requires a space of at least 1 inch (2.5 cm) between the wall and the machine on each side and at least 4 inches (10 cm) between the back of the washer and the wall. Additional space may be needed for servicing.

ACCESSORIES

The washer comes with the two input hoses. The blue stripe is for cold water and the red stripe is for hot water. The hoses are not mechanically identical. It is critical to the performance of the washer to have the hot and cold hoses connected correctly. The hot hose is a thicker material suitable for higher temperatures and pressure.

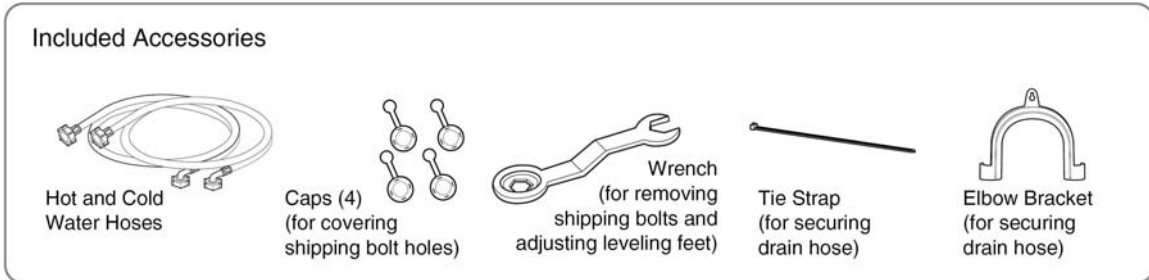

The wrench is used to remove (and replace) the shipping bolts and to adjust the leveling feet. Be sure to leave it and encourage the customer to retain the wrench, the four shipping bolts, and the manual in a safe place in the event the washer requires service or the customer moves.

The shipping bolts **MUST BE REMOVED** before operating the washer. (See page 13.)

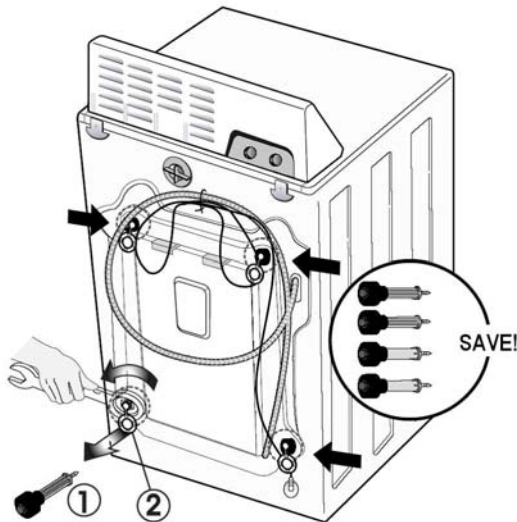

The wrench, shipping bolt hole covers, drain hose tie down strap, and a sample packet of detergent are included in a packet shipped inside the washer. See page 29 concerning detergent usage.



INSTALLATION

REMOVE THE SHIPPING BOLTS. LEAVE THEM WITH THE CUSTOMER.

The lower right bolt is equipped with a clip that secures the cord so it is impossible to plug in the machine without removing the bolt. The cord is further secured by an adhesive sticker which must be broken to free the cord to plug in the machine.



INSTALL THE WASHER ON A FIRM, FLAT SURFACE.

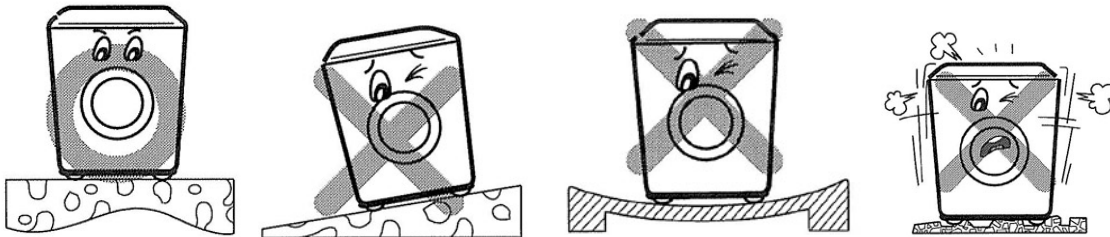

ADJUST THE FEET TO BE LEVEL. LOCK THE ADJUSTERS IN PLACE.

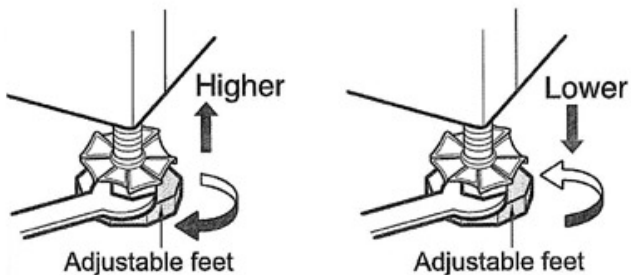

CONNECTIONS

WATER

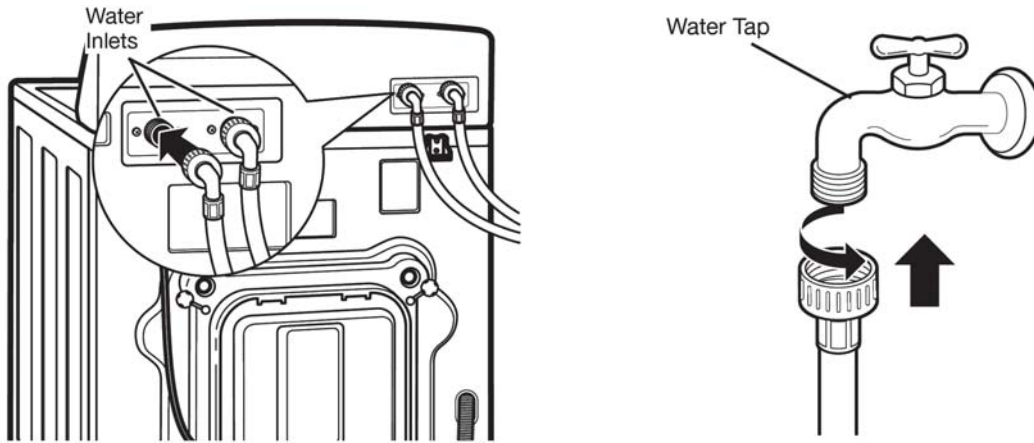

Be sure the rubber washer is inside the hose end. Attach the hoses to the washer (red is HOT, blue is COLD). Tighten them firmly but don't strip the plastic threads on the washer connections. The HOT hose is thicker and has a higher temperature rating and burst strength.

DRAIN

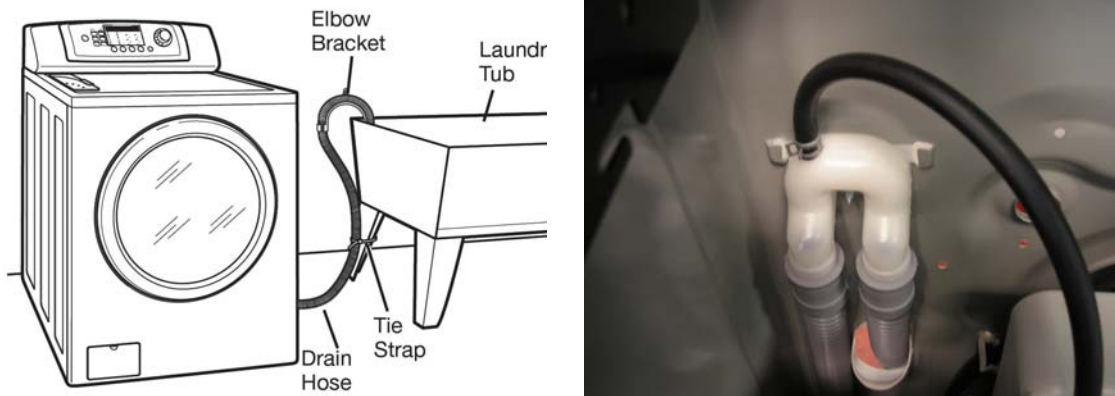

The drain pipe should be firmly attached to the standpipe or the laundry tub or sink where it drains. The pump has sufficient power to cause the pipe to move around when the water is expelled. The pump can lift the drain water a maximum of 96 inches (2.4 m), but there is no minimum height requirement. The vacuum breaker in the drain line will prevent drainage by gravity or siphoning. The hose can lay flat into a floor drain as long as the end of it is not submerged.

ELECTRICAL

The steam washer requires a 120 VAC, 60 Hz., dedicated, 20-amp circuit.

INSTALLATION (PEDESTAL KIT)

This procedure covers installing and leveling the 7½” and 13” pedestals for 27” washers, dryers, and combos. If the products are stacked, the washer must be below the dryer, and only one pedestal is required.

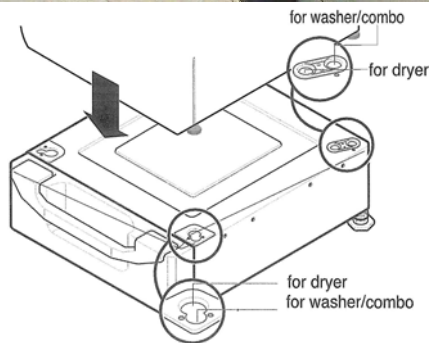
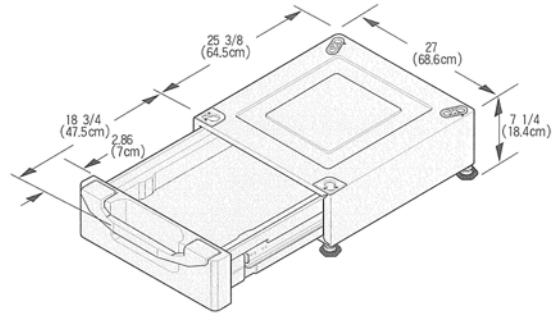

Remove the pedestal, installation hardware, and instructions from the shipping carton. Set the pedestal as close to the installation position as possible.

Level the pedestal on a flat, solid floor before proceeding. Lock down the rear adjusters but leave the front ones free for now.



Note which holes are for the washer and which are for the dryer. If you are stacking the appliances, the washer **must** be on the bottom.

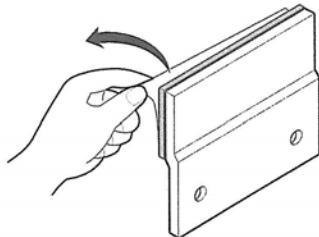

Remove the protective paper from the adhesive surface of the bracket. Be particularly careful, because when the adhesive makes contact, no adjustment is possible.

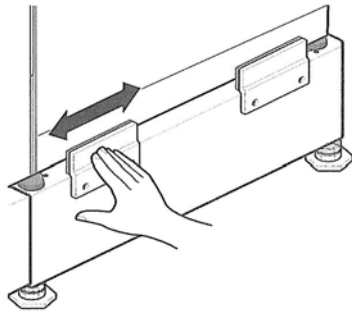
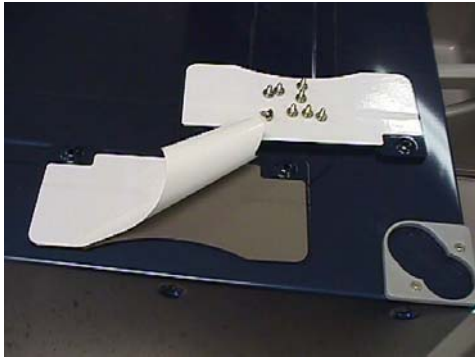
PEDESTAL, continued

Depending upon the model, your pedestal may have straight or curved brackets. The curved ones are to be used on the rear positions when mounting a dryer to a pedestal, but can also be used in any other position on the pedestal.

Holding the exposed adhesive away from the appliance, insert the screws and get them started. Then press the brackets to the appliance and tighten all the screws. Rub the bracket from side to side to ensure a complete bond.

Use the wrench to turn each leg of the appliance approximately $\frac{1}{4}$ turn to put a little pressure between the appliance and the pedestal. This will eliminate any rattles and vibration.

It is usually easier to set the pedestal and washer into place and connect the water and drain hoses before placing the dryer on top of them.

CONTROL PANEL

The control panel is located on the front of the Washer. All options are available from the control panel.

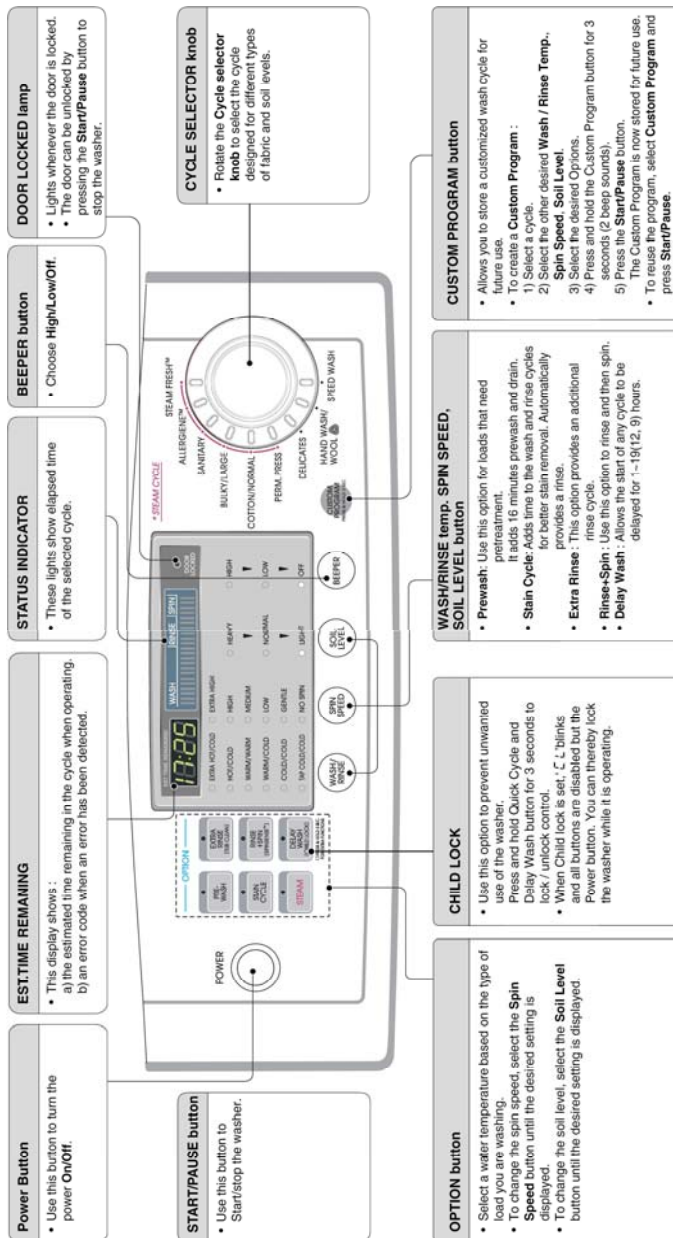

The ESTIMATED TIME remaining is shown in the window. This may fluctuate during the cycle because the washer will make numerous adjustments based on fuzzy logic and the data supplied by various sensors in the machine.

CHILD LOCK will render every button except the POWER button. CL blinks in the display when the CHILD LOCK is engaged. To turn off the machine if it is running with CHILD LOCK engaged, you must first disengage CHILD LOCK and then press POWER to turn it off.

The START/PAUSE button is incorporated into the CYCLE SELECTOR knob. Twist the knob to select a cycle; push it to push it to START or PAUSE the cycle.

The CUSTOM PROGRAM button allows the user to set all the desired options on a cycle commonly used so that cycle is then available at the touch of a single button.

The DOOR LOCKED light indicates that the door lock is engaged.

CYCLE and OPTION CHART

Cycle	Fabric Type	Wash/Rinse Temp.	Spin Speed	Soil Level	Pre-Wash	Rinse + Spin	Extra Rinse	Stain Cycle	Steam
Steam Fresh™	Dress shirts, blouses								●
Sanitary	Heavily soiled underwear, work clothes, diapers, etc.	Extra Hot/Cold	High	Normal					
			Extra High No Spin Low Medium	Heavy Light	●	●	●	●	●
Bulky/ Large	Large items such as blankets and comforters	Warm/Cold	Gentle	Normal					
		Warm/Warm Hot/Cold Tap Cold/Cold Cold/Cold	Low Medium No Spin	Heavy Light	●	●	●	●	●
Perm Press	Dress shirts/pants, wrinkle-free clothing, poly/cotton blend clothing, tablecloths	Warm/Cold	Medium	Normal					
		Warm/Warm Hot/Cold Tap Cold/Cold Cold/Cold	High No Spin Gentle Low	Heavy Light	●	●	●	●	●
Cotton/ Normal	Cotton, linen, towels, shirts, sheets, jeans, mixed loads	Warm/Cold	High	Normal					
		Warm/Warm Hot/Cold Tap Cold/Cold Cold/Cold	Extra High No Spin Low Medium	Heavy Light	●	●	●	●	●
Allergiene	Cotton, underwear, pillow covers, bed sheets, baby wear		High						
			No Spin Low Medium						●
Delicates	Dress shirts/blouses, nylons, sheer or lacy garments	Cold/Cold	Low	Normal					
		Warm/Cold Warm/Warm Tap Cold/Cold	Medium No Spin Gentle	Heavy Light	●	●	●		
Hand Wash/ Wool	Items labeled "hand-washable"	Warm/Cold	Low	Normal					
		Warm/Warm Tap Cold/Cold Cold/Cold	No Spin Gentle	Light		●	●		
Speed Wash	Lightly soiled clothing and small loads	Hot/Cold	Extra High	Light					
		Tap Cold/Cold Cold/Cold Warm/Cold Warm/Warm	No Spin Gentle Low Medium High	Normal Heavy		●	●		

See also the section covering PROCESS TECHNICAL INFORMATION on pages 89 and 90 of this training manual.

CYCLE and OPTION INFORMATION



OPTIONS (in general)

Every option is not available on every cycle. For example, steam and extra high spin cannot be selected with the HAND WASH/WOOL or DELICATES cycle. Similarly, certain hotter wash temperatures cannot be selected if that would be inappropriate for the materials or cycle selected. At any time the operator attempts to select an invalid choice, the machine will beep and refuse to accept the setting.

All temperatures and water levels listed are as accurate as possible, but there can be some slight variation due to incoming water temperature and voltage, laundry load type and size, and others.

STEAM

Steam can be added to every cycle except DELICATES, HAND WASH, WOOL, and SPEED WASH. It is locked out of these cycles to prevent damage to delicate clothing. While the laundry is washing, the steam generator boils water to spray steam through the laundry as it tumbles.

STEAM FRESH™

Steam Fresh™ is not an actual wash cycle. Instead, it is a cycle that tumbles up to five laundry items in a spray of steam to refresh the fabric and release the wrinkles. Water is not dispensed during the STEAMFRESH™ cycle. It is designed to refresh clothes that have been packed away, as in a suitcase or drawer, and make them look freshly laundered and ironed. It is NOT a substitute for dry cleaning and should not be used for any garment that is not designed to be washed in water. To run a STEAMFRESH™ cycle, press POWER and turn the cycle selector knob to STEAMFRESH™. The default setting is for 3 items, but it can be adjusted to freshen between 1 and 5 garments.

ALLERGIENETM

The Allergiene™ cycle is designed to use hotter wash water (140° F or 60° C) than the regular HOT wash (112° F or 50° C) but not as hot as the SANITARY cycle (158° F or 70° C). Its purpose is to remove all allergens, such as dust mites and their eggs and droppings, as well as lint and dead skin cells. This machine is certified allergy and asthma friendly by the Allergy and Asthma Foundation of America as removing 95% of harmful allergens. When the Allergiene™ cycle is operating, the display shows **1:50** at the beginning, the water level defaults to approximately **242** and spin defaults to HIGH. The steam generator operates as does the wash water heater in the bottom of the tub.

SANITARY

The sanitary cycle is used to reduce bacteria and germs, as in baby clothes and sick room linens. The wash water temperature defaults to 158° F (70° C) and cannot be adjusted.

BULKY / LARGE

The BULKY / LARGE cycle is designed to launder large items like tablecloths and bed covers. It is NOT intended as an opportunity to overload the machine. Just because an item can be forced into the tub is not evidence it can be successfully laundered there. In every case, the laundry must be able to tumble to be cleaned effectively. If you push a king-sized comforter into the tub, but it is so compressed it cannot tumble, it cannot be washed or rinsed effectively. Further, it will be unable to distribute itself within the drum for the spin cycle, and will cause the machine to run off balance and shut down because it cannot redistribute the load. Such large items should be taken to a commercial self-service laundry where oversized machines are available.

In the BULKY / LARGE cycle, the cycle time is preset. The default selections can be overridden for wash temperature, spin speed, and soil level. If a selection is not permissible with the cycle, the machine will beep and refuse to accept the setting.

COTTON / NORMAL

The COTTON / NORMAL cycle is the most often used cycle. It defaults to a **0:53** minute cycle time, but this may vary as the fuzzy logic makes numerous adjustments throughout the cycle. It is the only cycle that genuinely senses the load before displaying the approximate wash time. The water level defaults to approximately **239**. The default selections can be overridden for wash temperature, spin speed, and soil level.

PERM. PRESS

The permanent press cycle defaults to a **0:57** cycle time. The default selections can be overridden for wash temperature, spin speed, and soil level. Water level defaults to approximately **234**, which is more water than a normal cycle.

DELICATES

The delicate cycle defaults to a **0:42** minute cycle. The water level defaults to approximately **230**. The default selections can be overridden for wash temperature, spin speed, and soil level, but certain options cannot be selected, such as steam, very hot water, and high speed spin. If a selection is not permissible with the cycle, the machine will beep and refuse to accept the setting.

HAND WASH / WOOL

This cycle is designed for woolen articles and other garments that are suitable to be washed in water but must be treated very delicately. The HAND WASH / WOOL cycle defaults to a **0:55** minute cycle. Water level defaults to **230**. The drum tumbles very gently, making slightly less than one complete revolution per tumble, which is just enough to turn the load over in the water.

SPEED WASH

SPEED WASH is the quickest cycle that provides a complete wash and rinse. It defaults to a **0:35** minute cycle. The default selections can be overridden for wash temperature, spin speed, and soil level, very hot water, and high speed spin, but certain options cannot be selected. If a selection is not permissible with the cycle, the machine will beep and refuse to accept the setting. STEAM WASH defaults to a HOT wash, but most people find that overriding it to select WARM gives a better wash and less wrinkling.

OPTIONS

When a cycle is selected, options like water temperature, spin speed, are preset for that cycle, but they can be overridden by selecting one of the option buttons on the control panel. For example, selecting a COTTON/NORMAL cycle will automatically default to a WARM wash, COLD rinse, HIGH spin speed, and NORMAL soil level. Any of these settings may be overridden by changing the options at the control panel before the wash cycle is started.

Not every option is available for every cycle. As mentioned above, the DELICATE cycle will lock out selections HOT WASH water, HIGH spin speed, and STEAM in the cycle.

SPIN ONLY

The SPIN ONLY cycle is not shown on the console. To engage SPIN ONLY, Press POWER and then SPIN SPEED. The COTTON / NORMAL LED will light. The machine will default to a **0:13** minute cycle on high speed unless EXTRA HIGH SPIN is selected, which will increase cycle time to **0:17**. The drain pump is energized as required during the spin cycle to exhaust all the water extracted from the load.

PRE-WASH

Pre-wash adds a pre-wash cycle before the main wash cycle. Pre-wash fills the tub and dispenses what was put into the pre-wash detergent compartment. After filling and washing, the pre-wash water is pumped out and the main wash cycle begins.

STAIN CYCLE

The stain cycle adds time to the wash cycle and increases the temperature of the wash water for increased cleaning performance.

SPINSENSE™

SPINSENSE™ is a cycle that reduces the spin speed after sensing an unbalanced load. To engage the SPINSENSE™, press POWER and select a cycle. Press and hold the SPINSENSE™ (Rinse+Spin) button. SPINSENSE™ will remain engaged until it is disengaged by the user. Turning the machine off or losing power will not disable SPINSENSE™.

CHILD LOCK

CHILD LOCK is designed to disable the control pad after the cycle is started. To activate the CHILD LOCK after the cycle has begun, press and hold CHILD LOCK (Delay Start) until CL shows on the display. All controls will be disabled until the end of the cycle.

CUSTOM PROGRAM

The CUSTOM PROGRAM button allows the customer to set a commonly used program for personal convenience. For example, he may prefer the COTTON/NORMAL cycle but with a HOT WASH instead WARM, EXTRA HIGH SPIN instead of the regular spin, and a LIGHT SOIL level to shorten the cycle time. By programming these selections to the CUSTOM PROGRAM button, the customer can simply press it every time he wants to use this particular cycle. To program the CUSTOM PROGRAM BUTTON, press POWER.

select the desired cycle and options (as described above,) and then press and hold the CUSTOM PROGRAM for at least 3 seconds, until it beeps twice. Thereafter, simply press POWER, CUSTOM PROGRAM, and START to use this cycle.

TUB CLEAN

The TUB CLEAN cycle is designed to use extra hot water and a long wash cycle to remove soap scum and residue from the inside of the tub. Use it once a month to keep the washer clean and to prevent mildew and odor. Do not put laundry in to the tub during the TUB CLEAN cycle.

Press POWER and select any cycle. Then, press and hold TUB CLEAN for three seconds. The PRE-WASH pad will illuminate and the display will show **tCL**. Additives, such as one to remove the soap scum from whirlpool baths, can be added via the dispenser. Press START. The door will lock and the display will show **1:26**. The steam generator will be operated until **0:53** shows on the display. The water level will display approximately **225**. The tub will rotate and the recirculation pump will operate throughout the tub clean cycle. Near the end of the tub clean cycle, the washer will pump out the water and spin at **960** rpm until the end of the cycle. We recommend draining the water from the sump after running a tub clean cycle to ensure there are no residual cleaners or chemicals that might damage any subsequent load of laundry.

EXTRA RINSE

The EXTRA RINSE cycle inserts a second rinse cycle, which extends the cycle time accordingly.

RINSE+SPIN

RINSE+SPIN is provided to rinse laundry and spin it before drying it. It is most often used for previously washed laundry that was inadvertently left in the washer instead of being promptly transferred to the dryer or clothesline. Rinse temperatures are limited to COLD or WARM water. Changing the spin speed to EXTRA HIGH increases the cycle time by 0:04 minutes.

DELAY CYCLE

The DELAY CYCLE button allows the user to put laundry into the machine, add the appropriate additives (HE detergent, softener, and bleach,) set the desired cycle and options, and delaying the start time for up to 12 hours in 1-hour increments. This option is used to have the laundry ready to come out of the washer at a certain time, like when the customer gets home from work or after school, etc.

WATER TEMPERATURE CONTROL

PREWASH CYCLE

Cold water is supplied via the dispenser when the prewash valve opens. If COLD WASH / COLD RINSE is selected, the heater is not activated. If another WASH / RINSE temperature is selected, the heater still is not activated during the PREWASH unless the water temperature is lower than 85° F (29° C).

MAIN WASH and RINSE CYCLE

At the beginning of the prewash cycle, COLD water is supplied via the dispenser when the prewash valve opens. Then HOT or COLD water is applied as required to create a wash of the programmed temperature, as shown in the table below.

	EXTRA HOT	HOT	WARM	COLD
Set Point	158°F	122°F	104°F	86°F
Range (Wash)	158~167	122~131	104~113	50~86
Range (Rinse)			68~77	Tap

As used in the chart, the set point is the specified temperature setting (hot, warm, cold, et al) as recommend by the clothing manufacturers. In times past, HOT was whatever came out of the hot water faucet, COLD was whatever came out of the cold water faucet, and WARM was what happened with both valves opened. The washing machine uses a thermistor and computer to regulate the water input, adding hot or cold water as needed to adjust the temperature. If the washer cannot achieve the desired temperature with the addition of hot water to the tub, the heater will be activated and continue to operate until the desired temperature is achieved. When the desired setting is reached, the heater is turned off, and it will not come on again unless the temperature of the water in the tub decreases by 36°F (20° C.) For example, in the case of a HOT wash, when the water is heated to 122°F (50° C.)

In example 1, HOT / COLD temperatures are chosen for a NORMAL cycle. The prewash valve is opened and cold water is supplied briefly, then the hot valve is opened and water fills the tub until it reaches 131° F. As 131°F is hotter than the set point for HOT washing (122°F), the cold valve is opened to regulate the temperature to 122°F and the heater is never energized because the water temperature meets the target.

continued on next page

- A Prewash valve opens, cold water is supplied.
- B, D, and F Hot valve opens to raise the water temperature to 131° F.
- C, E, and G Cold valve opens to lower the water temperature to 122° F.
- H No water is supplied because the water level reaches the target.

Example 1

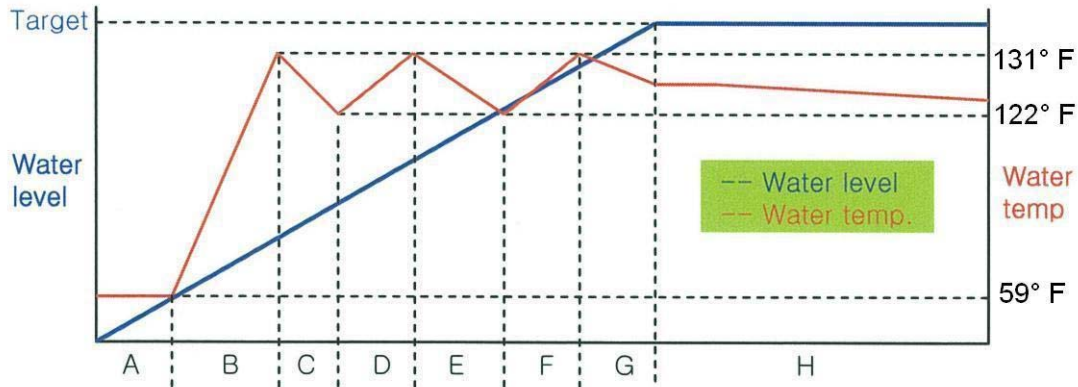

In example 2, HOT / COLD temperatures are chosen for a NORMAL cycle. The prewash valve is opened and cold water is supplied briefly, then the hot valve is opened and water fills the tub to the target water level. This water never reaches the set point, so the heater is energized. When the water temperature reaches 122° F, the heater is turned off.

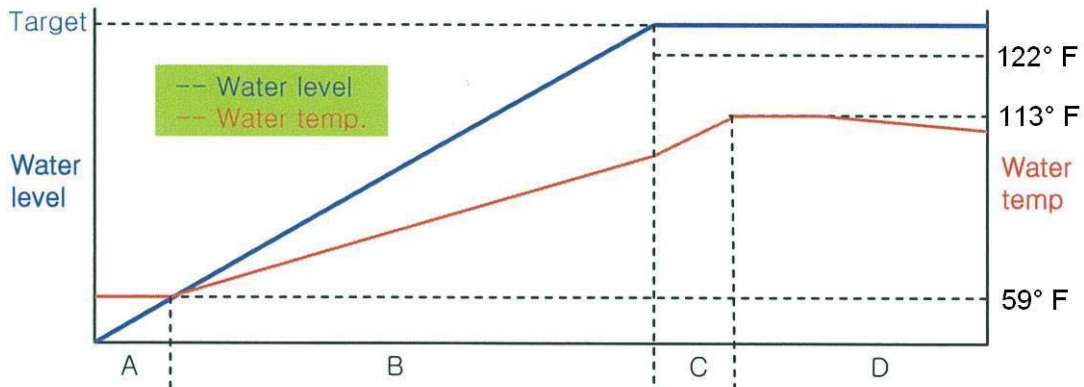

- A Prewash valve opens, cold water is supplied.
- B Hot valve opens to raise the water temperature to 122° F.
- C No cold water is supplied because it has already reached the target level.
- D Heater turns off when the water reaches the target temperature of 122° F.

WIRING DIAGRAM

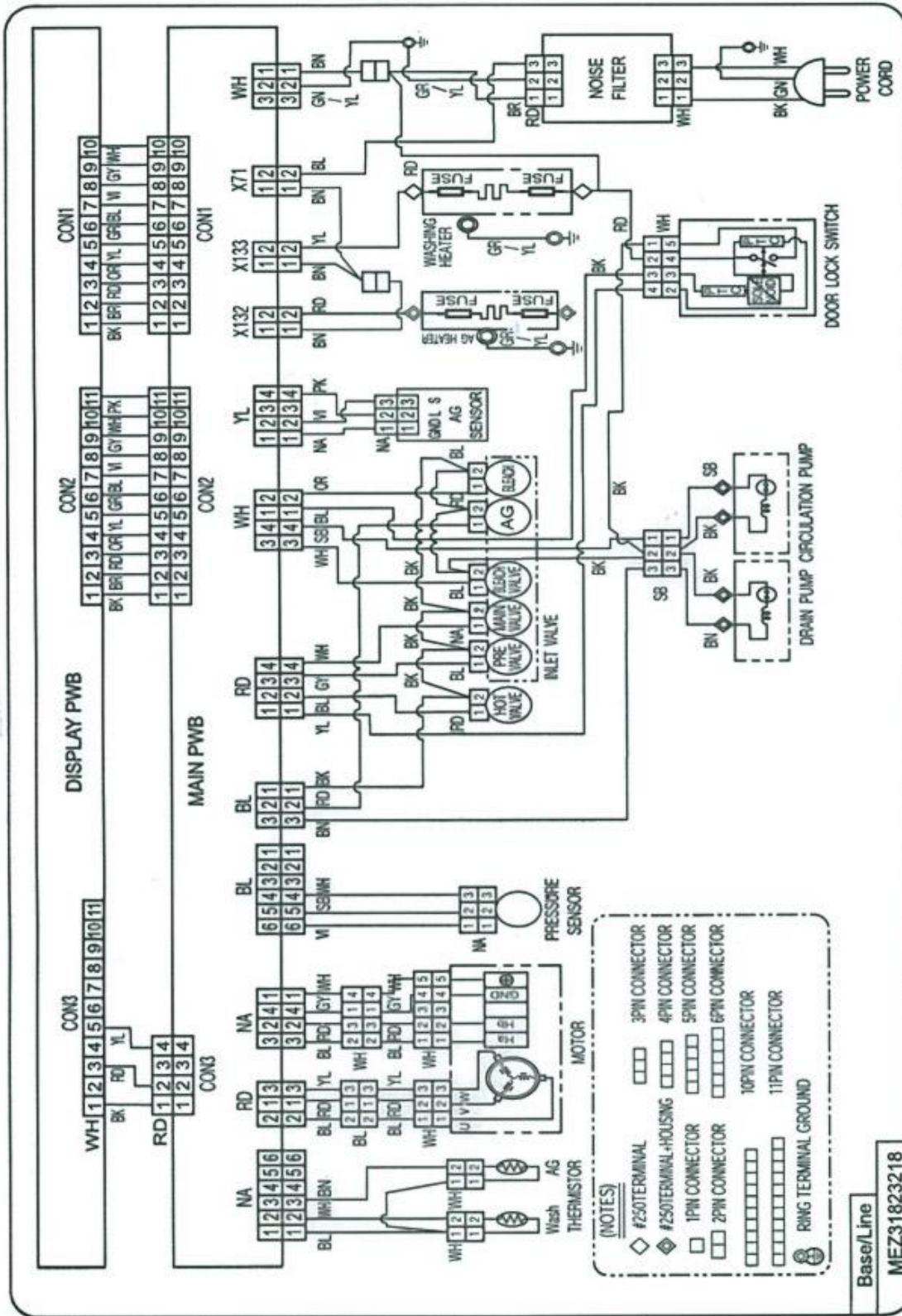

DISPENSER

The dispenser is a multi-chambered reservoir that allows the user to add all the appropriate laundry additives before starting the cycle. It has a place for pre-wash detergent, main wash detergent, fabric softener, and bleach. Powdered or liquid detergents may be used, but softener and bleach must be liquids. Detergents **MUST** carry the **HE** designation. Do not use regular detergents in the washer or oversudsing will occur.



The top of the dispenser box is shown here.



The dispenser works by using various solenoids to apply water to different compartments. There are two compartments for detergent. You may use liquid detergent products in the main wash compartment. However, if you use a pre-wash cycle and put liquid detergent into both compartments, all the detergent will run into the pre-wash cycle, causing oversudsing followed by a wash cycle with no detergent. To use the pre-wash cycle, you may use either liquid or powdered detergent, but you **MUST** use a powdered detergent for the main wash.

If liquid detergent is added to the pre-wash box, it will run immediately into the tub. This does not affect the operation of the cycle. You **must** use powdered detergent in the main wash compartment if using the pre-wash cycle. Otherwise, the main wash liquid detergent will run into the tub along with the pre-wash detergent, causing oversudsing in the pre-wash and no cleaning in the main wash.

Liquid fabric softener and bleach are dispensed from siphon boxes. As the appropriate chamber is flooded, the water flushes the laundry product into the tub where it is mixed with water before contacting the laundry to prevent spotting or damaging the fabric.

The siphon boxes are designed to hold a liquid laundry product until the appropriate time for dispensing into the load. When the box fills with water, it begins to discharge its contents into the washer fill stream. Once the siphon action has started, it will continue until the siphon box has emptied itself. Use only regular viscosity bleaches and softeners; the ultra versions are usually much thicker and do not dispense well, if at all.



Disassemble and clean the dispenser and siphon boxes if a build-up occurs.

Lift off the white plastic siphon cover. Wash the covers and the blue container. Reassemble and use it as usual. It is helpful to use laundry products of a normal viscosity (thin, like water) rather than the ultra or concentrated products (thick, like molasses) that do not flow easily.

We recommend the **RULE OF TWOS** concerning laundry products. Use no more than **TWO TABLESPOONS** of detergent in either the pre-wash or the main wash cycles. Use no more than **TWO TEASPOONS** of softener or bleach. While some **HE** laundry detergents suggest the use of as much as 4 ounces per load, this is entirely too much detergent. It will leave detergent film on your clothes, causing them to be dull and dingy. Over time, it will cause a thick film to build up on the inner surface of the tub. This buildup may become so thick it causes friction when the drum rotates, which will cause a malfunction of the machine. It will also generate a foul odor. While the use of a cleaning agent, like one designed to remove the soap scum from a whirlpool bath, will sometimes help, the best way to resolve this issue is to disassemble the machine, split the tub, and use a pressure washer to remove the build up. This is costly, and we recommend using the appropriate amounts of detergent and other laundry additives to prevent such an occurrence.

Due to the design of the machine, we do not recommend using it to soak or dye clothing, nor do we recommend the use of various laundry additives such as enzyme pre-soaks, detergent boosters, borax additives, bluing, and others.

DISPENSER HOSE CONNECTIONS

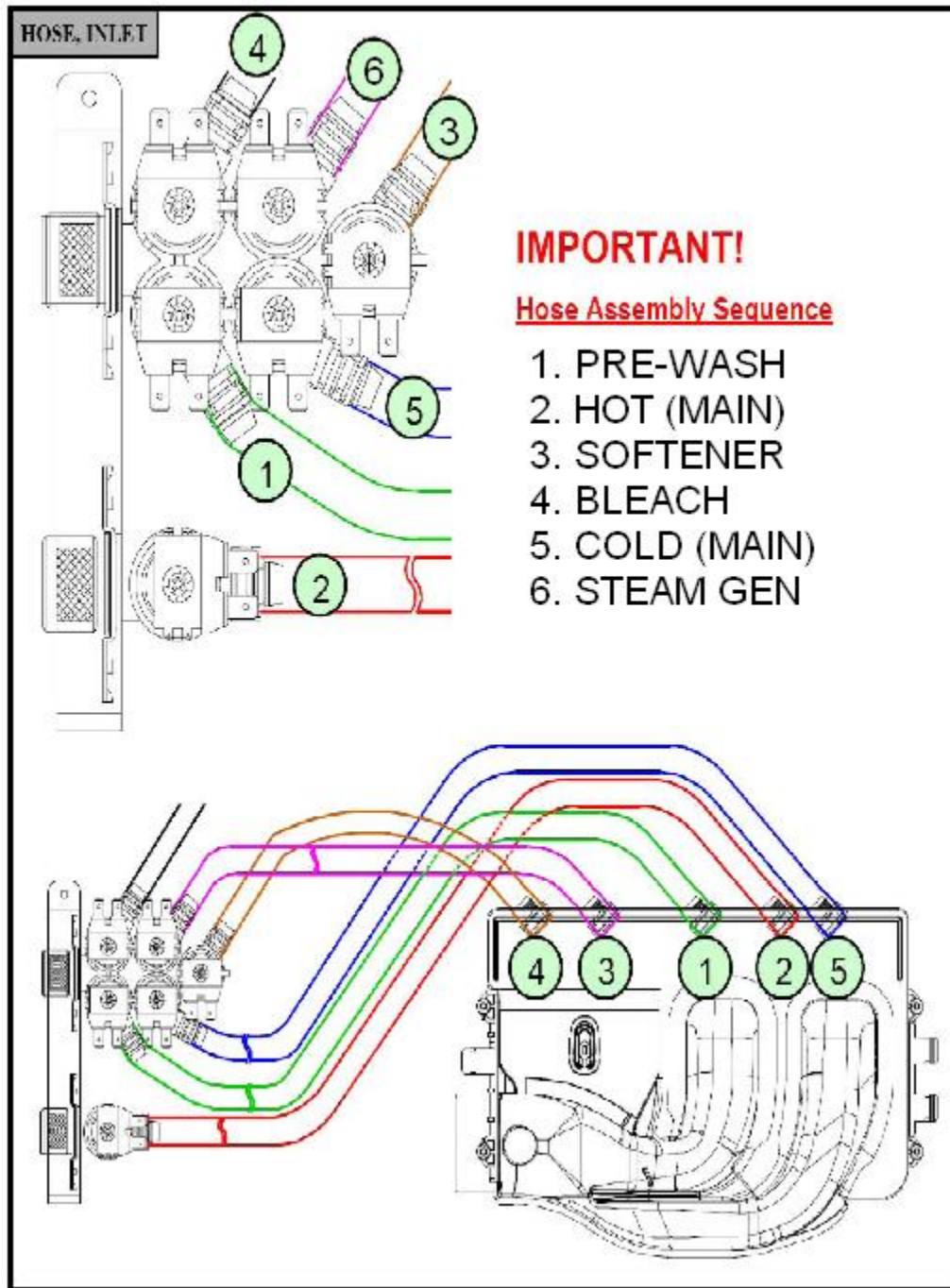

DIRECT DRIVE MOTOR



The motor is a direct-drive, brushless, DC motor. It is attached to the drum via a splined shaft, eliminating belts, pulleys, transmissions, and the inherent problems associated with them. The rotor is attached to the shaft by one large bolt.

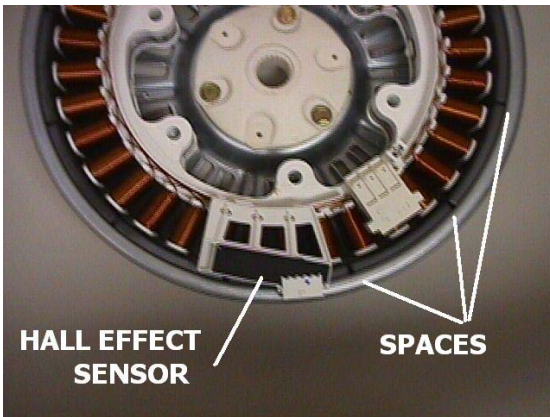

The DC motor can be driven from stopped to maximum speed in infinite steps in either direction. There are 36 poles on the stator; 12 permanent magnets spaced around the rotor. There are no brushes to wear out. Unlike a more traditional brushless motor, the rotor surrounds the stator rather than being attached to it. A Hall Effect Sensor determines the speed and direction of the motor. It also can read that the load is off balance when the drum speed fluctuates.

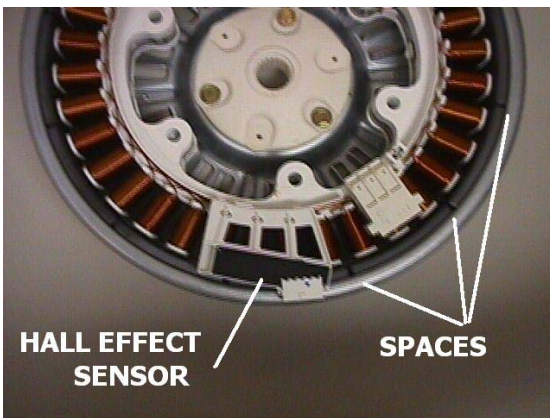

The Hall Effect sensor is easily removed and replaced. You'll have to remove the rotor and stator to access the sensor. When replacing the rotor, the drum may move forward enough to make replacing the bolt difficult. Carry a longer bolt in your toolbox to use to install the rotor, then remove and replace it with the factory bolt after the shaft has been pulled back and the rotor is pushed in place.

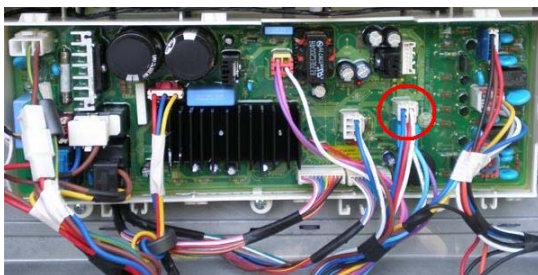

Before going to this trouble, check the connector on the main board. It is the white connector (circled in red.) Pull the connector off and verify the board is receiving a signal from the hall sensor. (See pages 48 ~ 52 for more information.)

DISASSEMBLY and REPAIR

The following pages will show the instructions for disassembly, repair, replacement of parts, and re-assembly. Many times, electrical components may be tested by connecting the appropriate meter to the leads or connectors on the main PC Board. (Refer to the block wiring diagram, below.) Proper diagnosis will eliminate unnecessary labor and expedite repairs.

BLOCK WIRING DIAGRAM

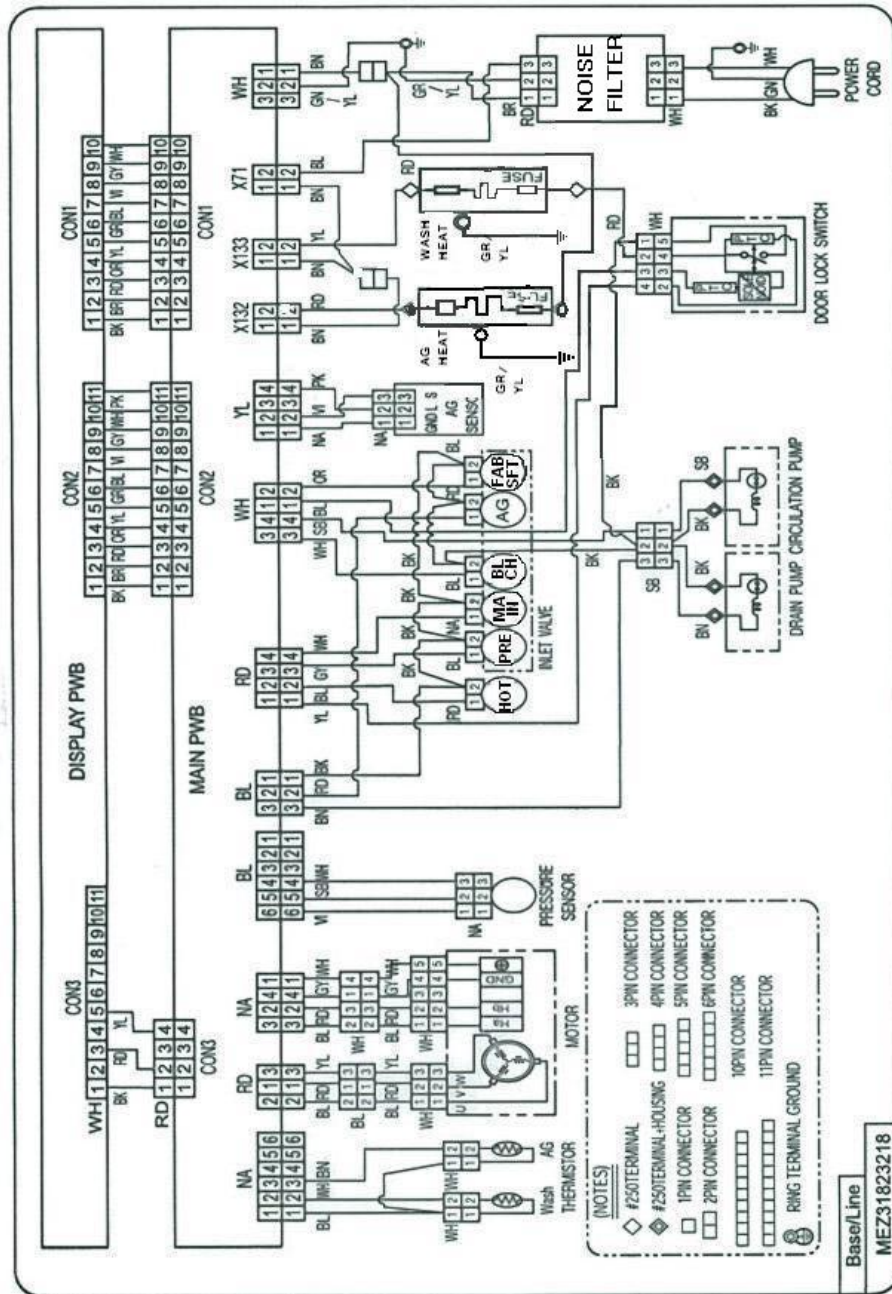

DISASSEMBLY/REPAIR (Control Panel)

CONTROL PANEL

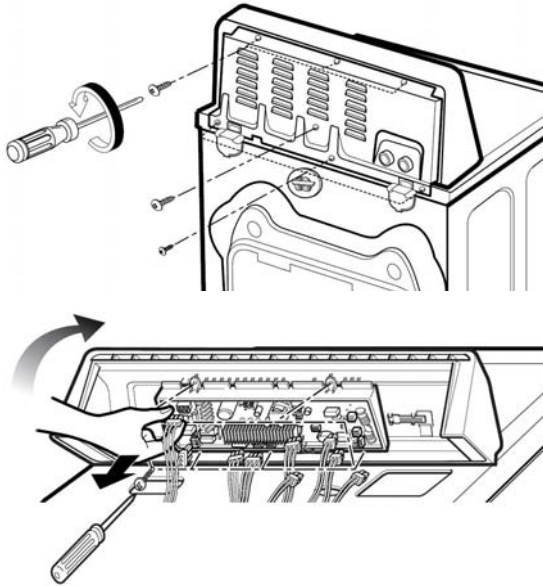

Remove the 7 screws on the back cover of the control panel.

Remove the rear cover.

Roll the control panel forward. Lay a towel or soft cloth on the washer to prevent damage to the control panel.

Unplug all the connectors.

Remove 5 screws and take the board out of the control panel.

TOP COVER

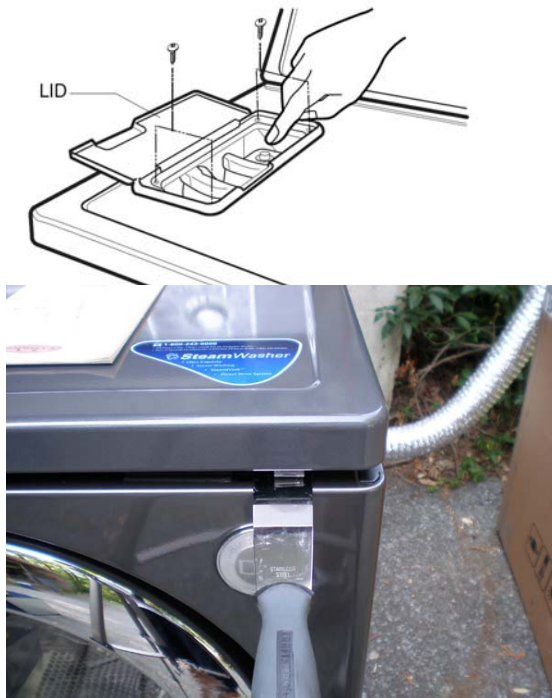

Open the dispenser lid and remove the 4 screws.

Take the lid assembly out of the top cover.

Release the plastic tabs that hold the dispenser assembly into the top cover.

Put your hand into the hole left by the dispenser and hold the top cover.

Use a putty knife or a thin blade to release the clip and lift the top cover. Repeat the process on the other side of the cover and raise the cover off the machine.

Be careful to avoid letting it fall on you while you are working in the machine.

DISASSEMBLY and REPAIR, continued

DISPENSER

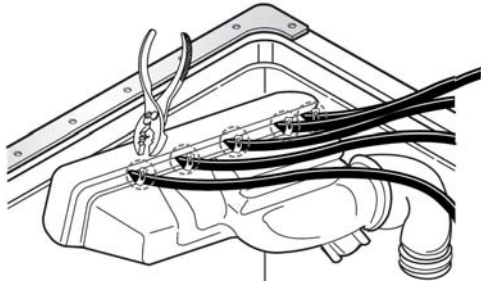

Remove the 5 hose clamps. If you squeeze them and slide them a couple of inches down the hose, they will not be lost while the repair is made.

Pull the 5 hoses off the connectors on the dispenser. Reassembly will be very convenient later if you mark the hoses now.

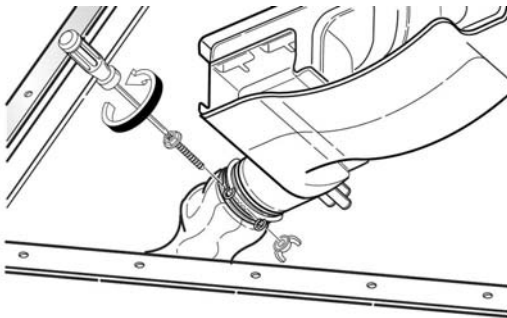

Remove the clamp on the large hose attached to the dispenser. (When you replace it, set it with the screw on top and the wing nut on the bottom for easier reach in the future.)

Pull the large hose off the dispenser and remove the dispenser from the machine.



Unplug all the solenoids. (As with the hoses, reconnection will be more convenient if you mark the connectors and valves now.)

Remove the two screws at the back of the machine and lift out the solenoid array.

NOISE FILTER

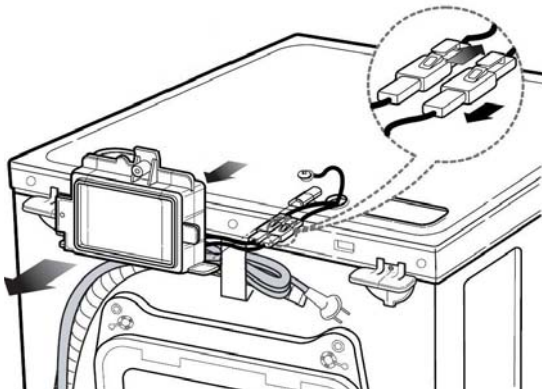

To service the noise filter, remove the control panel cover.

Unplug the two connectors of the noise filter and slide it out of the clips on the frame.

DISASSEMBLY and REPAIR, continued

FRONT COVER



Remove the control panel and top cover as shown on page 32 and set them aside.

Open the filter and drain cover.

Remove the screw securing the cover and pry the cover out with a screwdriver or putty knife. Be careful to avoid damaging the rim of the opening.

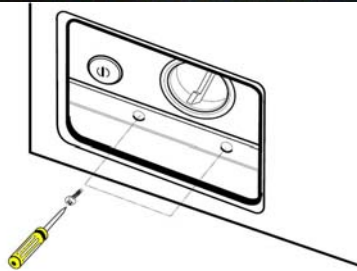

With the filter cover removed, remove the two screws that secure the base of the front cover to the machine frame.

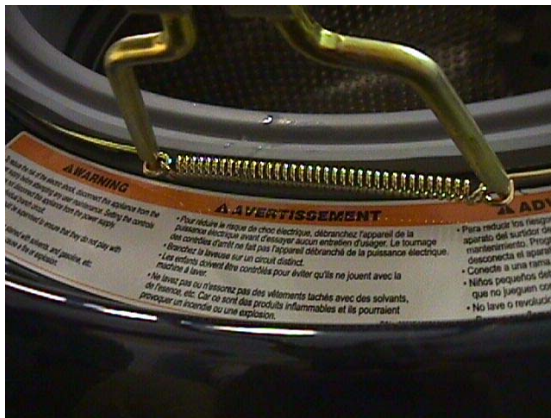

Remove the door gasket using the special tool 383EER4001A to remove the spring clamp.



After removing the door gasket, you can reach inside the cabinet and unplug the electrical connector to the door switch.

If you are replacing the door switch, you can do it without any disassembly other than the door gasket. Remove the two screws that hold the switch in place, pull it out through the opening, and replace it.

DISASSEMBLY and REPAIR, continued

FRONT COVER, continued

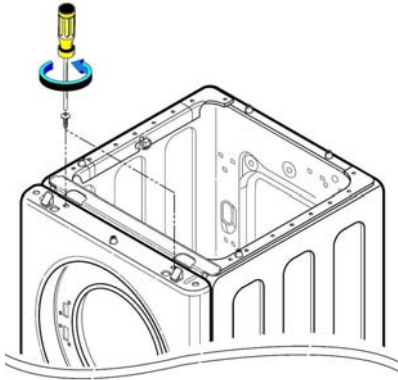

Remove the two screws that secure the top of the front cover. Be careful that the front does not fall forward, causing injury or damage.

Set it aside face down on a blanket or protective surface.

DOOR and HINGE

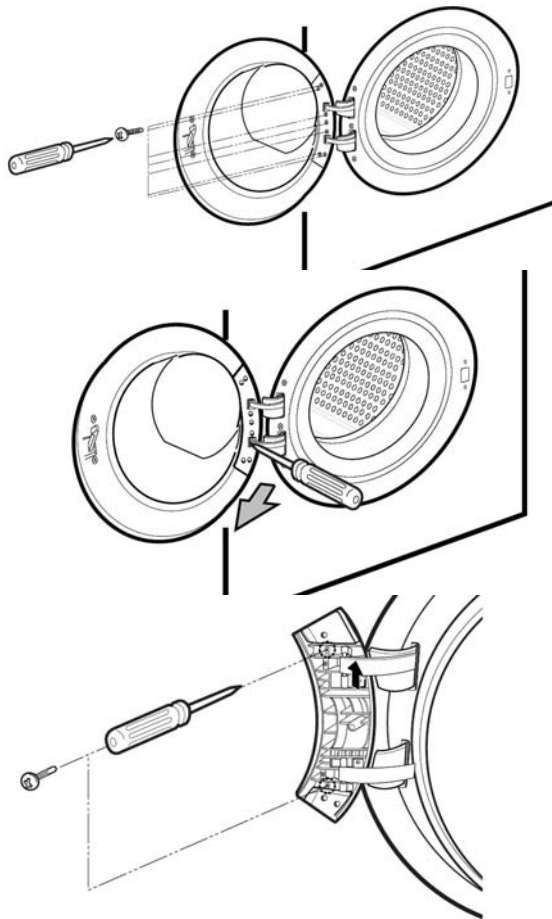

Open the door.

Remove the 7 screws that secure the hinge cover.

Pry the cover off with a screwdriver.

Remove the screws from the door hinge clips.

Lift the door off the hinge and set it aside. Be sure to retain the plastic hinge shims.

DISASSEMBLY and REPAIR, continued

PUMPS and FILTER HOUSING

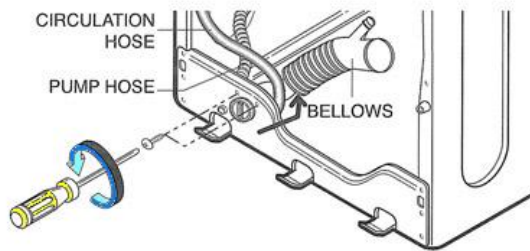

Remove the front cabinet. (See page 36.)

Drain the water from the sump.
Remove the clamps and hoses.

Remove two screws and push the pump backward and up.



Press down the plastic tab on the base to slide the pump assembly backward.

This tab is for the convenience of the workers in the assembly plant. It holds the pump in place while the machine is assembled. If you break it, don't worry about it. The slot in the base and the two screws on the front will hold the pump securely in place.

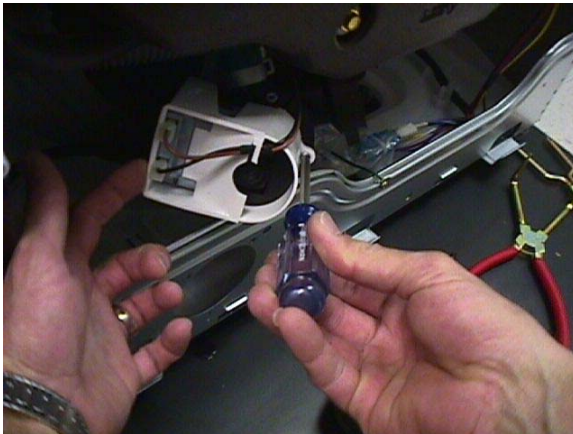

You can tilt the pump in either direction to remove/replace the individual pumps without having to remove the tub.

Have a towel handy to catch the spillage.

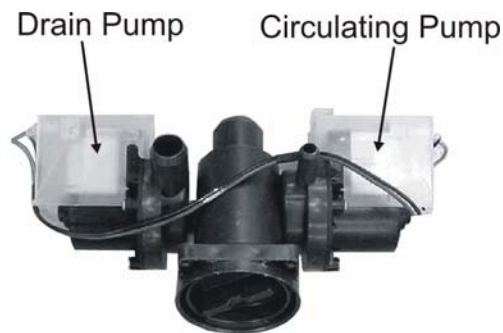

DISASSEMBLY and REPAIR, continued

DRAIN PUMP, continued

The drain pump and the circulating pump are attached to either side of the filter housing. The drain pump is used to exhaust the water from the washer. The recirculating pump serves three purposes: it sprays water from the tub onto the laundry, creating a better saturation of detergent and better rinsing, it keeps the window clean, and it allows the customer to see water in the tub. The filter between the pumps is not a lint filter in the traditional sense. It serves to trap larger objects (keys, coins, buttons, etc.) that may find their way into the washer and protects the pumps from physical damage.

WASH HEATER



Remove the front cover.

Disconnect the two electrical connections to the heater leads.

Disconnect the thermistor.

Remove the nut and ground wire on the heating element.

Loosen as far as possible but do not remove the second nut on the ground lug. This will release the tension on the gasket and allow the heater to be pulled out of the tub.

When replacing the heater, be sure the element slides into the retaining clip on the bottom of the tub.

FOREIGN OBJECT REMOVAL



Remove the front cover.

Remove the heater element, as described above.

You can then use a wire to fish out any foreign objects that have come between the drum and the tub.

Replace the heater, as described above.

DISASSEMBLY and REPAIR, continued

WATER LEVEL SWITCH

The water level detector switch monitors the water level and feeds this information to the main board. The sensor reads air pressure in an air chamber on the tub. The air pressure changes in relation to the depth of the water, moving a diaphragm in the switch. As the water level fluctuates, it raises or lowers the iron center in the coil, which, in turn, changes the electric resonance of the oscillator circuit of which it is a part. As water level decreases, frequency increases.

(e.g. A low water level may read **25.5 kHz**, while a high water level may read **21.4 kHz**. These readings are approximate; washers in the field may vary slightly from these figures.)

To read the frequency while the WM0742 is running, simultaneously press and hold the **SOIL LEVEL** and **CUSTOM** buttons. The number on the display should be divided by 10 to obtain the frequency reading in kHz. A display of **254** would indicate a frequency of **25.4 kHz**. The MICOM interprets the frequency reading as one of eight levels, with one being the lowest water level and any level greater than eight indicating an overflow situation.

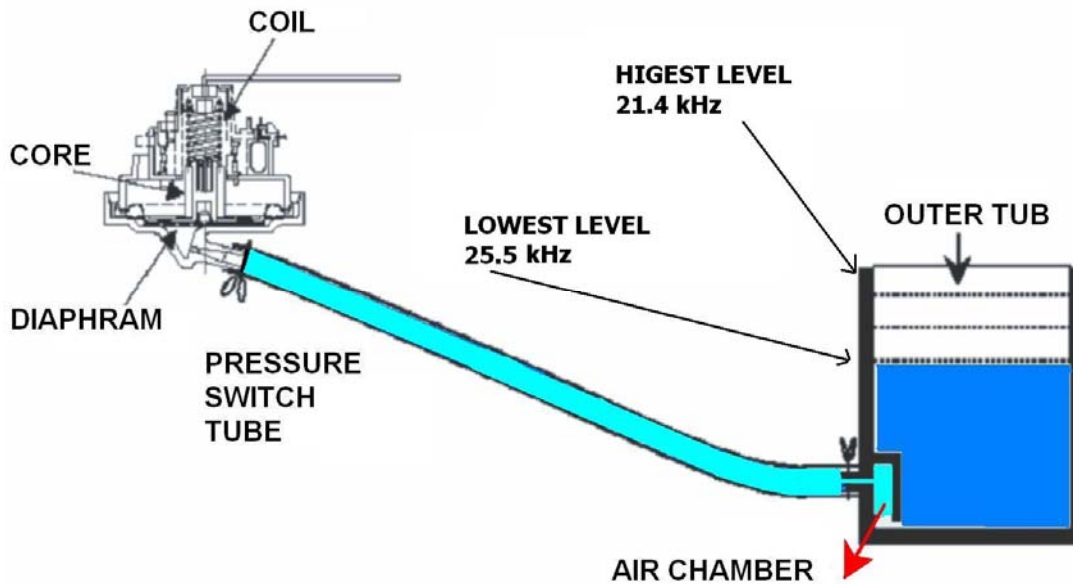

DISASSEMBLY and REPAIR, continued

MOTOR

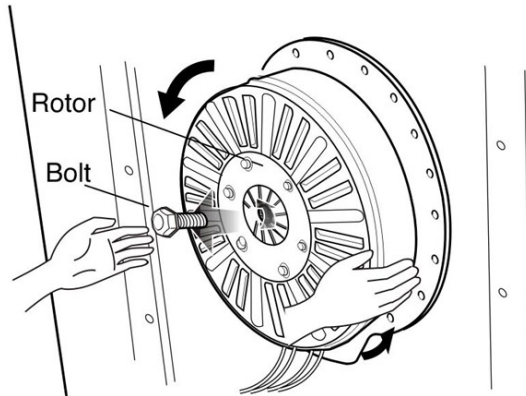

Remove the back cover.

Remove the large bolt in the center shaft.

DO NOT stick a screwdriver or other object through the slots in the rotor.

Pull the rotor off the shaft.

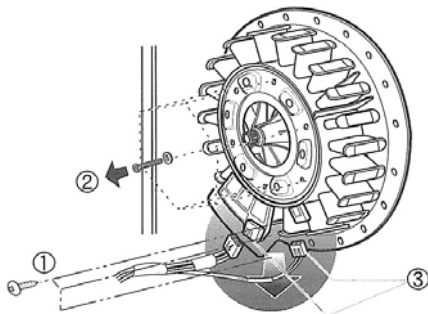

Remove the ground screws and wire retainers from the stator wires. (See photo, below.)

Remove two screws from the tub bracket.

Remove six bolts on the stator. Lift it off and support it while you unplug two connectors on the stator.

Set the stator aside.

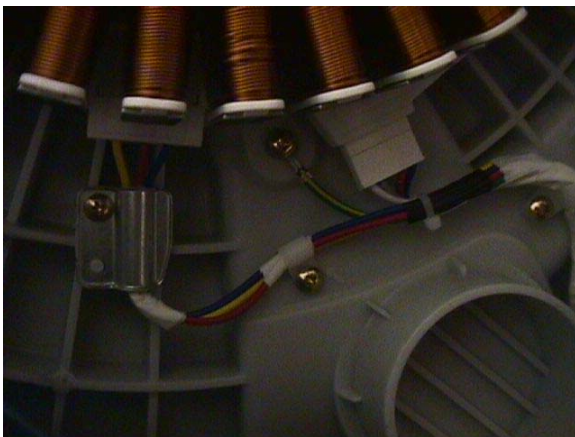

When re-installing the stator, the clamps and the ground screw must be installed and the connectors pressed into place before the rotor is bolted onto the shaft.

When you replace the rotor, the shaft can be pressed forward so far the bolt will not reach it. If you can't hold the tub back while you install the bolt, get a longer bolt with the same thread. Place the rotor onto the shaft, install the long bolt, and pull the shaft back while you push the rotor all the way on. Then remove the long bolt and replace it with the correct bolt. Tighten to specification.

DISASSEMBLY and REPAIR, continued

TUB and DRUM



Removing the tub/drum assembly is major surgery. It is much lighter if you remove the weights and the motor. Generally speaking, you'll have to remove all that anyway.

Remove the motor. (See page 40.)

Drain the water from the sump.

Remove the control panel. (See page 32.)

Remove the front cabinet. (See page 36.)

Disconnect all hoses and electrical connections.

Separate the three dampers. (See page 42.) You can remove just one end now and the other end after the drum is out of the machine.

Pry apart the spring retainer clip.

Carefully lift the tub up off the springs and remove it from the machine.



Unbolt the bolts around the circumference of the seam. Separate the halves. Be careful to avoid damaging the gasket. Do not pry on the surfaces between the halves.

Instead of replacing the bearings, we recommend purchasing the back half of the tub with the bearings already pressed in at the factory.

DISASSEMBLY and REPAIR, continued

DAMPERS



Disconnect the dampers from the tub and the base. (See photos, left.)

Be sure to press in the safety tab before pushing the pin out of the damper. You can use a socket to hold the tab in while you squeeze the pin with the special tool **383EER4003A**.



The flat end of the tool goes on the small end and the split end allows the head end to pass through while the pin is pushed out. Sometimes you can use a socket to hold the pin down while you press the pin out.

The color and/or appearance of the damper may vary by model but the operation is the same.

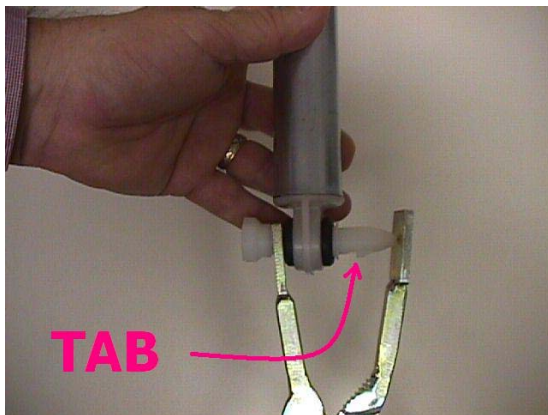

Use special tool **383EER4003A** to remove the damper pins. If you are replacing the dampers, you'll have to remove both ends. If you are removing the tub for major repair work, disconnect the damper ends at the base and leave the other ends connected until you remove the tub. When putting the tub back into the machine, connect the dampers to the tub first. It is much easier that way.

Be careful not to pull the dampers apart while they are disconnected. If you break them, they must be replaced, and they should be replaced as a set.

DISASSEMBLY and REPAIR, continued

TURBO STEAM GENERATOR

The TSG (Turbo Steam Generator) is supplied as an assembly only; parts like the sensor, thermistor, or heater cannot be replaced individually. Diagnosis is limited to determining malfunction and replacing as an assembly. The steam generator does not have to be removed from the machine to be drained. Be sure to let the water cool to avoid a burn. Have a hose available to slip onto the connector or a large towel to catch the water so it doesn't run down into the machine cabinet. If you remove the steam generator before draining it, be sure to avoid tipping it and spilling the water.

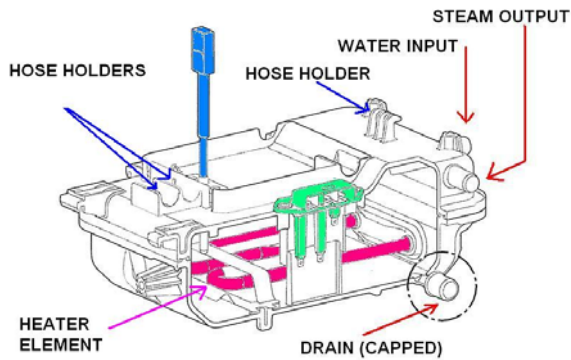

The steam generator can be removed as an assembly for diagnosis and replacement.

Unplug the washer.

Disconnect all electrical connections, including ground.

Drain the water. (You can drain the water later and it is easier.)

Remove all the cable straps by squeezing the tabs and pulling them out. They can be reused.

Remove the four screws holding the support rail in place and two screws attaching the steam generator.

Disconnect the hoses (water input and steam output.)

Push the steam generator toward the back of the washer to release it from the side rail. You can then remove it for draining, inspection, and replacement.

It is sold as an assembly only and is not repairable.

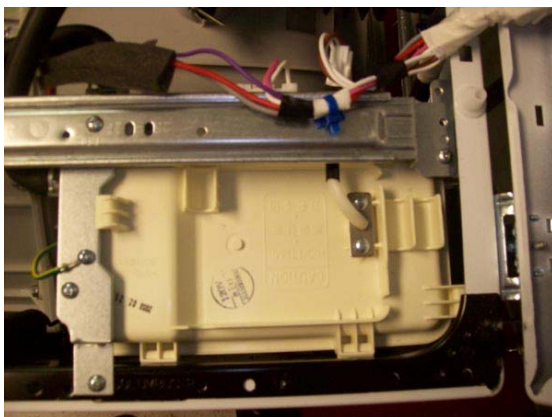
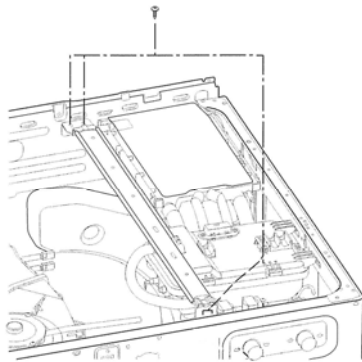

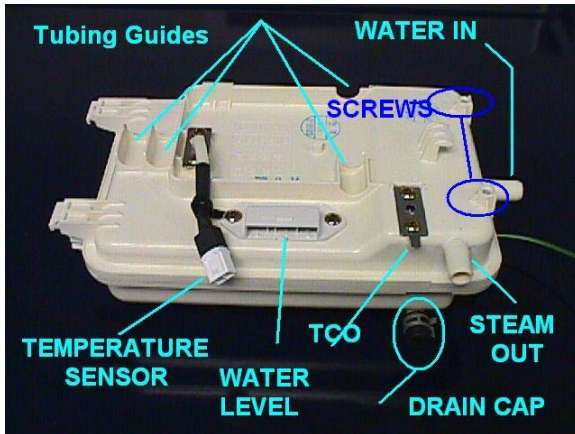

When the Turbo Steam Generator is installed in the washer, the hoses to the dispenser should fit into the tubing guides.



Be particularly careful when removing and replacing the water input hose to the steam generator. There is a check valve that fits into the input port. The valve sometimes comes off and is stuck in the hose. This could cause the water not to flow, which would cause the steam generator to malfunction.

More recent models have a retainer built into the check valve to eliminate this issue.



Pull the check valve out of the hose gently and replace it into the water input port. Then slide the hose onto the port and install the clamp.

Sensor Wiring Diagram

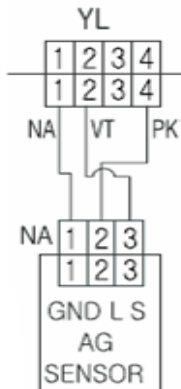

Steam Generator



The Steam Generator is made up of 5 major components. They are the 1,100 watt heater @ 120 V_{AC}, the low water sensor, the high water sensor, the temperature sensing thermistor, and the water tank.

The water level sensors, the thermistor, along with the control board determine IF the steam generator heater will be activated. To the left and above you will see the wiring diagram for the water level sensors. The picture above shows 3 connectors. The rear connector with black and white leads is the temperature sensing thermistor. The center connector with a pink and white wire is the low water sensor. The front connector with a single violet lead is the high water sensor.

From the wiring diagram you will see that the white wire (NA) is the GND reference. The Pink wire is the low water sensor lead. The violet lead is the high water sensor lead.

Low Water Sensor Sensing Water



The sensors operate in a 5 V_{DC} environment. When water is present and conductivity exists from the white GND lead and the pink low water sense lead, less than 1.5 V_{DC} will be measured.

If the water tank were empty, the low water reading from WH to PK would be greater than 3 V_{DC}.

(See High Water Sensor, Next page.)

High Water Sensor Sensing Low Water



The photo to the left shows the high water sensor (Violet) wire. As the caption shows the meter is reading a voltage of 4.09 V_{DC}. Water in the housing is not touching the high water probe. When this occurs, the control board would activate the cold inlet valve for the steam generator before energizing the heater, IF steam was selected and the control board wanted steam.

High Water Sensor Sensing Full



In this picture we see the meter displaying less than 1.5 V_{DC}. In this example, the water in the housing is touching the high water sensor probe and the ground probe. When this occurs, conductivity through the water is measured as a voltage drop and the control board knows the water housing is full of water.

Steam Generator Wiring



Steam Generator



The steam generator heater is shown on the previous page. The heater operates on 120 V_{AC} @ 1,100 Watts. The amperage is approximately 9 amps. The wiring shows a gray wire (L1) and a red wire (Neutral.)

When STEAM is selected or a TUB CLEAN cycle is selected, the control board will verify a high water level, add water via the cold valve if needed, and then energize the heater. After several minutes steam is produced.

Serviceability is limited to testing component functions and available voltages or amperages. If any component fails, the steam generator must be replaced as an assembly.

The thermistor is a NTC (Negative Temperature Coefficient) device; as temperature goes up, resistance goes down. The ohm value at room temperature is approximately 60K Ω and the voltage measured across the sensor is approximately 3.6 V_{DC}. At 212° the ohm value is approximately 3.3 K Ω and the voltage measured across the sensor is 0.88 V_{DC}.

In the test mode, the heater will be ON for 1.5 seconds and the temperature for the steam generator will be displayed in degrees Celsius. While in the test mode, with the thermistor open or disconnected, the heater will not heat and the display will show 0. In a steam cycle, the heater will be OFF if the sensor is open or disconnected.

HALL SENSOR TEST, DIAGNOSIS, and REPAIR

Check the wiring diagram for your machine. The wiring diagrams on some washing machines were incorrect in depicting the hall sensor wiring. The error involves wiring terminal designation. See the diagrams below.

The correct wiring terminal colors are:

White is (+)
Red is Hb

Gray is (-)
Blue is Ha.

The correct depiction is shown **left** and the incorrect depiction is shown **right**.

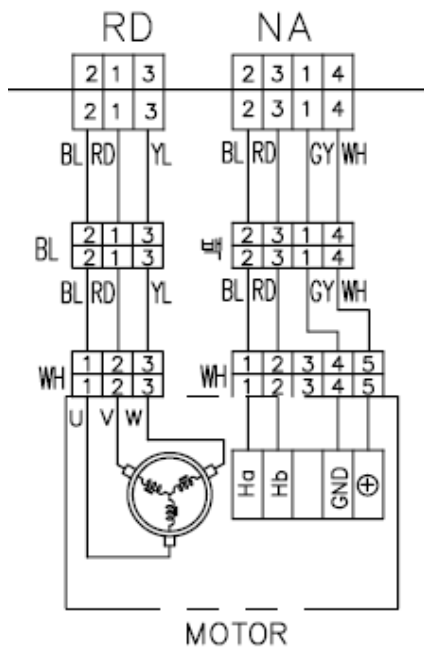

Correct

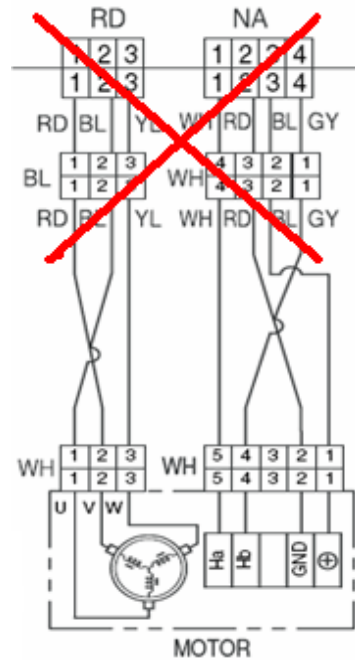

Incorrect

Pay particular attention to the **color codes** and the **position numbers** in the connectors. This will be critical when you take voltage readings to determine component malfunction.

Hall Sensor testing methods are now available on the following pages when LE error code troubleshooting says *“hall sensor is out of order or defective.”*

Test FIRST!!

<p>LOCKED MOTOR ERROR</p>		<ul style="list-style-type: none"> • The connector (3-pin, male, white) in the MOTOR HARNESS is not connected to the connector (3-pin, female, white) of STATOR ASSEMBLY. • The electric contact between the connectors (3-pin, male, white) in the MOTOR HARNESS and 4-pin, female, white connector in the MAIN PWB ASSEMBLY is bad or unstable. • The MOTOR HARNESS between the STATOR ASSEMBLY and MAIN PWB ASSEMBLY is cut (open circuited). • The hall sensor is out of order/defective.
-----------------------------------	-----------------------------------------------------------------------------------	-----------------------------------------------------------------------------------------------------------------------------------------------------------------------------------------------------------------------------------------------------------------------------------------------------------------------------------------------------------------------------------------------------------------------------------------------------------------------------------------------------------------------------------------

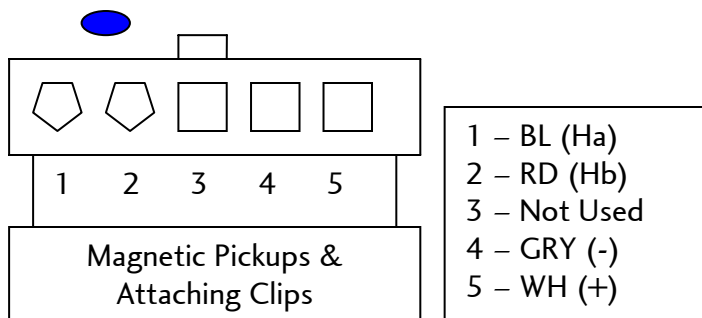

OHM Checking	Voltage Checking
5 to 1 = 10 K Ω	
5 to 4 = 10 to 15 V _{DC} Voltage Input	
5 to 2 = 10 K Ω	
4 to 1 = pulsing 10 V _{DC} Signal Output	
4 to 2 = pulsing 10 V _{DC} Signal Output	
<i>Note: Ohm values are approximate; if the ohm check determines either resistor open, the hall sensor has failed and must be replaced!!</i>	

Terminal Designation / Ohm & Voltage Specifications

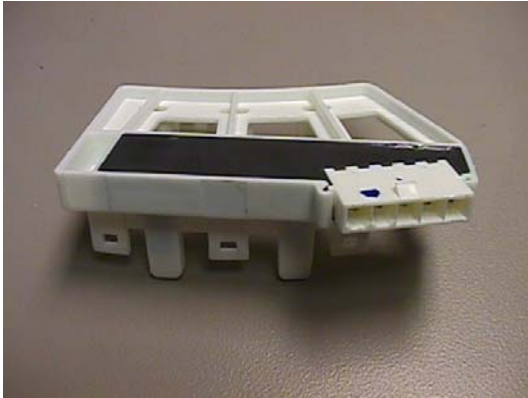

Part No. 6501KW2002A

Hall Sensor Testing

The hall sensor can be tested from the control board or at the hall sensor.

Ohm Testing the Hall Sensor

If tested off the stator using the diagram on the previous page, ohm check the resistors from pin 5 to pin 1 and pin 2. If the hall sensor is good, you should measure approximately 10 K Ω from pin 5 to pin 1 and 10 K Ω from pin 5 to pin 2. If either test shows an open (infinity) the hall sensor is defective and must be replaced.

Voltage Testing Hall Sensor at Stator

If measuring voltage from the control board to the hall sensor, follow the following steps:

1. Unplug the power cord.
2. Remove the rear washer panel.
3. Locate the Hall sensor connector on the stator behind the rotor.
4. Place the meter leads on terminals 5 to 4, white to gray.
5. Plug in the power cord, close the door, and press the power button.
DO NOT PRESS START!
6. You should measure 10 to 15 V_{DC}. If 10 to 15 V_{DC} is present, the control board is OK! ***If not, follow the testing output voltages on control board in next section.***
7. To measure output signal voltage from the hall sensor, carefully move test leads to terminals 4 (gray) to 1 (blue). Slowly rotate the motor rotor by hand. You should read a pulsing 10 V_{DC}. If 10V_{DC} is measured from 4 to 1, move the lead on the blue wire to the red wire, terminal 2. Repeat rotating motor rotor by hand. You should read a pulsing 10 V_{DC}.
8. If pulsing 10 V_{DC} is measured from pin 4 to pin 1 and pin 4 to pin 2, the hall sensor is OK! If either test netted only 9 to 10 V_{DC} without changing (no pulsing) the hall sensor is likely defective. Disconnect power by unplugging the washer. Ohm check the hall sensor as outlined in **Ohm Testing The Hall Sensor** (see above) to verify failure of the hall sensor.

Testing the Hall Sensor from the Control Board

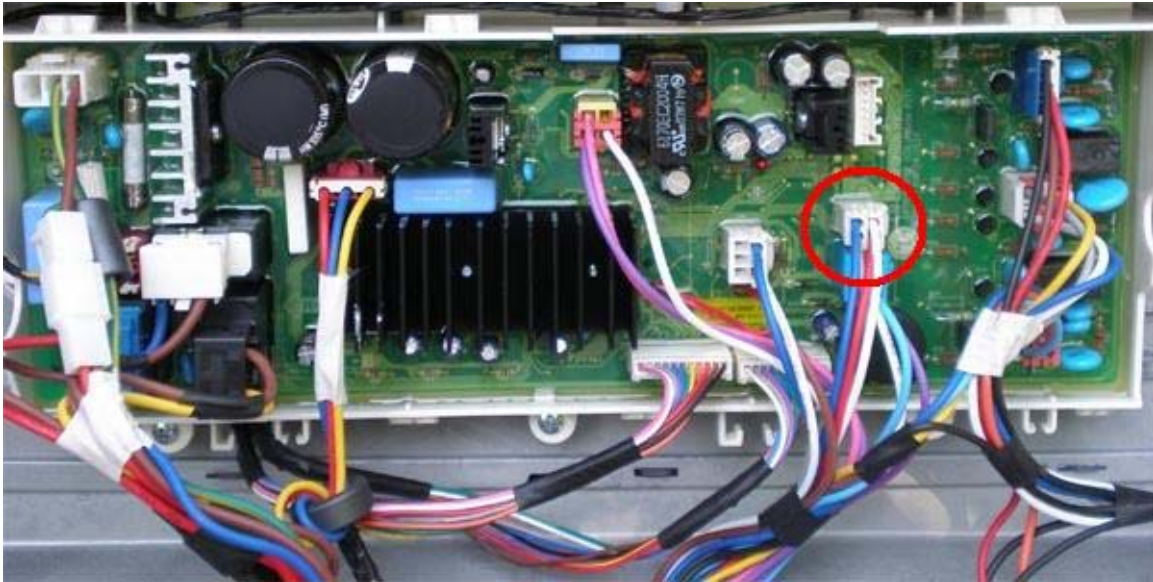

Control Board Testing Location

Control Board Output and Hall Sensor Input can be measured with the connector connected to the board and the machine operating. Also, these voltages can be measured by parking the meter leads on the desired terminals and spinning the tub briskly with the power cord disconnected.

- White to Gray – 10 to 15 V_{DC}
- Gray to Blue – pulsing 10 V_{DC}
- Gray to Red – pulsing 10 V_{DC}

Note: If 10 V_{DC} from gray-to-blue or gray-to-red **does not** change (pulse), that resistor is open! Confirm by disconnecting the power, disconnecting the hall sensor connector on the main board, and ohm checking that individual circuit!

With power disconnected and the connector disconnected, the hall sensor can be tested ohmmetrically from:

- White to Blue – 10 K Ω
- White to Red – 10 K Ω

Note: Ohm values are approximate; if either ohm check shows an open, the wire harness is open or the hall sensor is defective. Test both separately to determine the exact location of the failure!

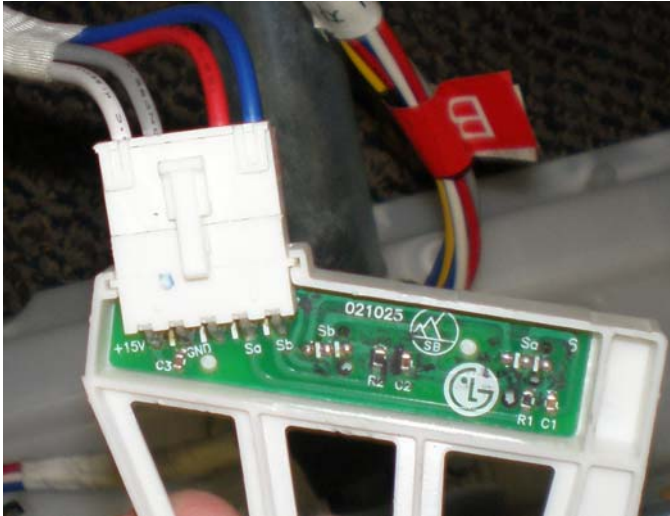

Actual Terminal Wiring

The potting epoxy has been removed to show the PC board and components.

Voltage Testing Hall Sensor at Control Board (See page 50.)

1. Unplug the power cord.
2. Remove the rear control panel cover.
3. Remove the top plate.
4. Remove the main board from the rear cabinet corner.
5. Identify the hall sensor connector on the main board, as shown on page 68, using the wiring diagram and wire colors as your guide. (See wiring diagram and main board photo, page 68.)
6. Plug in the power cord, close the door, and press **POWER**.

DO NOT PRESS START!

7. Place your meter leads on the **WHITE** and **GRAY** wires. You should read between 10 ~ 15 V_{DC} output from the main board to the hall sensor. If 10 ~ 15 V_{DC} are not observed, the main board is defective.
8. Place your meter leads on the **BLUE** and **GRAY** wires. Turn the motor rotor slowly by hand. You should measure a pulsing 10 V_{DC}. Place your meter leads on the **RED** and **GRAY** wires. Turn the motor rotor slowly by hand. You should measure a pulsing 10 V_{DC}.

If both of these tests measure a pulsing 10 V_{DC}, the hall sensor and wiring harness are OK. If either or both tests measures 9 ~ 10 V_{DC} but does not pulse or change, the hall sensor has failed and must be replaced.

If either test measures 0 (zero) voltage, check the red and blue wires for continuity. Repair or replace the wiring harness as necessary.

TEST MODE

The steam washer must be empty and off to enter the test mode.

1. Press and hold **SPIN SPEED** and **SOIL LEVEL**.
2. Press **POWER**. The buzzer will sound twice.
3. Press **START/PAUSE** to cycle through the test modes. (See chart, below.)

Number of times Start/Pause pressed	Event	Display
None	All lamps on / door locked	18:84
1	Drain pump/Tumble clockwise	rpm ¹ (42 ~ 50)
2	Spin – Low speed	rpm ¹ (55 ~ 65) ¹
3	Spin – High Speed	rpm ¹ (105 ~ 125) ¹
4	Pre-wash valve (Cold)	Water level freq. (25 ~ 65) ²
5	Main wash valve (Cold)	Water level freq. (25 ~ 65) ²
6	Main wash valve (Hot)	Water level freq. (25 ~ 65) ²
7	Softener valve (Cold)	Water level freq. (25 ~ 65) ²
8	Bleach valve (Cold)	Water level freq. (25 fl 65) ²
9	Steam valve (Cold)	Water level freq. (25 fl 65) ²
10	Tumble counterclockwise	rpm ¹ (42 ~ 50)
11	Tub heater (1.2 seconds)	Water temperature (tub) °C ³
12	Circulation pump	Water level freq. (25 ~ 65) ²
13	Drain pump	Water level freq. (25 ~ 65) ²
14	Water level sensor (steam)	Water level freq. (31 ~ 246) ²
15	Steam generator heater	Water temperature (TSG) °C ³
16	Off	

- Notes: 1. Insert a **zero** at the end of the displayed numbers to determine the actual rpm. 62 indicates 620 rpm; 115 indicates 1,150 rpm.
2. Insert a **2** at the beginning of the displayed number to determine the actual water level frequency. 65 indicates 265 or 26.5 KHz.
3. Temperatures are displayed in degrees Celsius.

The following button combinations allow access to these sensor readings:







PREWASH and CUSTOM	Steam generator temperature in °C
WASH/RINSE and CUSTOM	Tub water temperature in °C
SOIL LEVEL and CUSTOM	Water level (displayed as a frequency)
SPIN SPEED and CUSTOM	Drum rpm speed (see note above)

ERROR DISPLAY

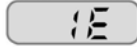
If you press START/PAUSE when an error code is displayed, any error except **PE** will disappear and the machine will revert to PAUSE status. In the cases of a **PE**, **TE**, or **DE** error code, if the error is not cleared within 20 seconds, the machine will be turned off automatically and the error code will blink on the display. In the case of any other error code, if the error is not cleared within 4 minutes, the machine will be turned off automatically and the error code will blink on the display.

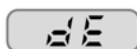

In the event of an **FE** error code, the machine will be turned off and will not be restarted.

ERROR CODES

	ERROR	SYMPTOM	CAUSE
1	WATER INLET ERROR		<ul style="list-style-type: none"> • Correct water level (230~238) is not reached within 8 minutes after water is supplied or it does not reach the preset water level within 25 minutes.
2	IMBALANCE ERROR		<ul style="list-style-type: none"> • The load is too small. • The appliance is tilted. • Laundry is gathered to one side. • Non distributable things are put into the drum.
3	DRAIN ERROR		<ul style="list-style-type: none"> • Not fully drained within 10 minutes.
4	OVER FLOW ERROR		<ul style="list-style-type: none"> • Water is overflowing (water level frequency is over 213).
5	PRESSURE SENSOR ERROR		<ul style="list-style-type: none"> • The SENSOR SWITCH ASSEMBLY is out of order.
6	DOOR OPEN ERROR		<ul style="list-style-type: none"> • Door not all the way closed. • Loose electrical connections at Door switch and PWB Assembly. • The DOOR SWITCH ASSEMBLY is out of order.
7	HEATING ERROR		<ul style="list-style-type: none"> • The THERMISTOR is out order.







continued on next page

ERROR CODES, continued

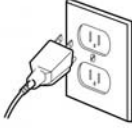
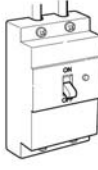
	ERROR	SYMPTOM	CAUSE
8	LOCKED MOTOR ERROR		<ul style="list-style-type: none"> • The connector (3-pin, male, white) in the MOTOR HARNESS is not connected to the connector (3-pin, female, white) of STATOR ASSEMBLY. • The electric contact between the connectors (3-pin, male, white) in the MOTOR HARNESS and 4-pin, female, white connector in the MAIN PWB ASSEMBLY is bad or unstable. • The MOTOR HARNESS between the STATOR ASSEMBLY and MAIN PWB ASSEMBLY is cut (open circuited). • The hall sensor is out of order/defective.
9	EEPROM ERROR		<ul style="list-style-type: none"> • EEPROM is out of order. ※ Displayed only when the START/PAUSE button is first pressed in the QC Test Mode.
10	POWER FAILURE		<ul style="list-style-type: none"> • The washer experienced a power failure.



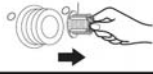

DIAGNOSIS and CHECK LIST (Abnormal Operation)

NO POWER, NO WATER INPUT

SYMPTOM	GUIDE FOR SERVICE CALL
<p style="text-align: center;">No power</p>	<div style="display: flex; justify-content: space-between;"> <div style="width: 60%;"> <p style="border: 1px solid black; padding: 5px; margin-bottom: 10px;">Is the power plug connected firmly to 120 V AC outlet?</p> <p style="text-align: center; font-weight: bold;">YES</p> <p style="border: 1px solid black; padding: 5px; margin-bottom: 10px;">Power failure? or Breaker opened? Is the outlet controlled by a switch?</p> <p style="text-align: center; font-weight: bold;">NO</p> <p style="border: 1px solid black; border-radius: 15px; padding: 5px; text-align: center; margin-top: 20px;">Visit to service</p> </div> <div style="width: 35%; text-align: center;">   </div> </div>
<p style="text-align: center;">Water inlet trouble</p> <div style="text-align: center; margin: 10px 0;">  </div>	<div style="display: flex; justify-content: space-between;"> <div style="width: 60%;"> <p style="border: 1px solid black; padding: 5px; margin-bottom: 10px;">Is  displayed?</p> <p style="text-align: center; font-weight: bold;">YES</p> <p style="border: 1px solid black; padding: 5px; margin-bottom: 10px;">Is the tap opened?</p> <p style="text-align: center; font-weight: bold;">YES</p> <p style="border: 1px solid black; padding: 5px; margin-bottom: 10px;">Is the tap frozen?</p> <p style="text-align: center; font-weight: bold;">NO</p> <p style="border: 1px solid black; padding: 5px; margin-bottom: 10px;">Is the water supply shut-off?</p> <p style="text-align: center; font-weight: bold;">NO</p> <p style="border: 1px solid black; padding: 5px; margin-bottom: 10px;">Is filter in the inlet valve clogged with foreign material?</p> <p style="text-align: center; font-weight: bold;">NO</p> <p style="border: 1px solid black; border-radius: 15px; padding: 5px; text-align: center; margin-top: 20px;">Visit to service</p> </div> <div style="width: 35%; text-align: center;">     <div style="border: 1px solid black; padding: 5px; margin-top: 10px;"> <p style="text-align: center; font-weight: bold;">Clean the filter of inlet valve.</p>  </div> </div> </div>

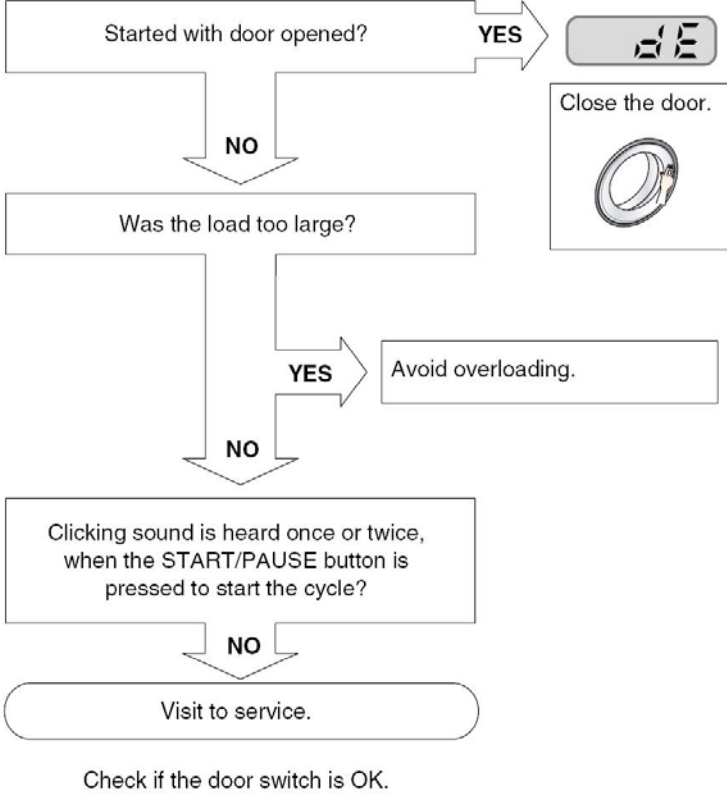
DIAGNOSIS and CHECK LIST (Abnormal Operation), continued

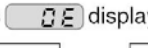
DOOR ERROR, DRAIN ERROR

SYMPTOM	GUIDE FOR SERVICE CALL
<p>Door error</p> 	<div style="text-align: center;"> <p>Started with door opened? YES →</p>  </div>
<p>Drain trouble</p> 	<div style="text-align: center;"> <p>Is  displayed? YES ↓</p> <p>Is the drain pump filter clogged with foreign material such as pins, coins, etc? YES →</p> <p>Clean up the filter </p> <p>Is the drain hose frozen, kinked, or crushed? NO ↓</p>  <p>Visit to service.</p> </div>

DIAGNOSIS and CHECK LIST (Abnormal Operation), continued

OVERSUDSING, NO SOFTENING, ERROR CODES

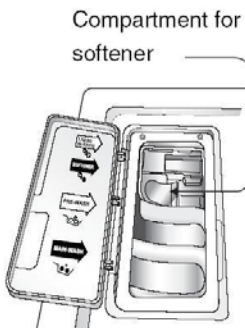
SYMPTOM	GUIDE FOR SERVICE CALL
<p>Suds overflow from the appliance. (In this condition, wash and spin do not operate normally)</p>	<div style="display: flex; justify-content: space-between; align-items: center;"> <div style="width: 60%;"> <p>Is a HE(High Efficiency) detergent used?</p> <p style="text-align: center;">↓ YES ↓</p> <p>Is the proper amount of detergent used as recommended?</p> <p style="text-align: center;">↓ YES ↓</p> <p style="border: 1px solid black; border-radius: 15px; padding: 5px; text-align: center;">Recommend to reduce the amount of detergent.</p> <ul style="list-style-type: none"> * This appliance has an a automatic suds sensing function which prevent overflow. * When excessive suds are sensed, the suds removing implementations such as drain, water input, pause will operate, without rotating the drum. </div> <div style="width: 35%; text-align: center;">  </div> </div>
<p>No softening effect</p>	<div style="display: flex; justify-content: space-between; align-items: center;"> <div style="width: 60%;"> <p>Is softener put in the correct compartment of the dispenser?</p> <p style="text-align: center;">↓ YES ↓</p> <p>Is the softener cap clogged?</p> <p style="text-align: center;">↓ YES ↓</p> <p style="border: 1px solid black; border-radius: 15px; padding: 5px; text-align: center;">Explain proper use of softener.</p> <p style="text-align: center;">Clean the compartment for softener</p> </div> <div style="width: 35%; text-align: center;">  </div> </div>
<div style="display: flex; flex-wrap: wrap; justify-content: center; gap: 10px;"> <div style="border: 1px solid gray; border-radius: 5px; padding: 2px 5px; margin: 2px;">FE</div> <div style="border: 1px solid gray; border-radius: 5px; padding: 2px 5px; margin: 2px;">FE</div> <div style="border: 1px solid gray; border-radius: 5px; padding: 2px 5px; margin: 2px;">LE</div> <div style="border: 1px solid gray; border-radius: 5px; padding: 2px 5px; margin: 2px;">LE</div> </div>	<p style="text-align: center; border: 1px solid black; border-radius: 15px; padding: 10px;"> Visit to service. To resolve an LE error, see the section on Hall Sensor Diagnosis and Repair, page 48. </p>

FAULT DIAGNOSIS and TROUBLESHOOTING

NO POWER

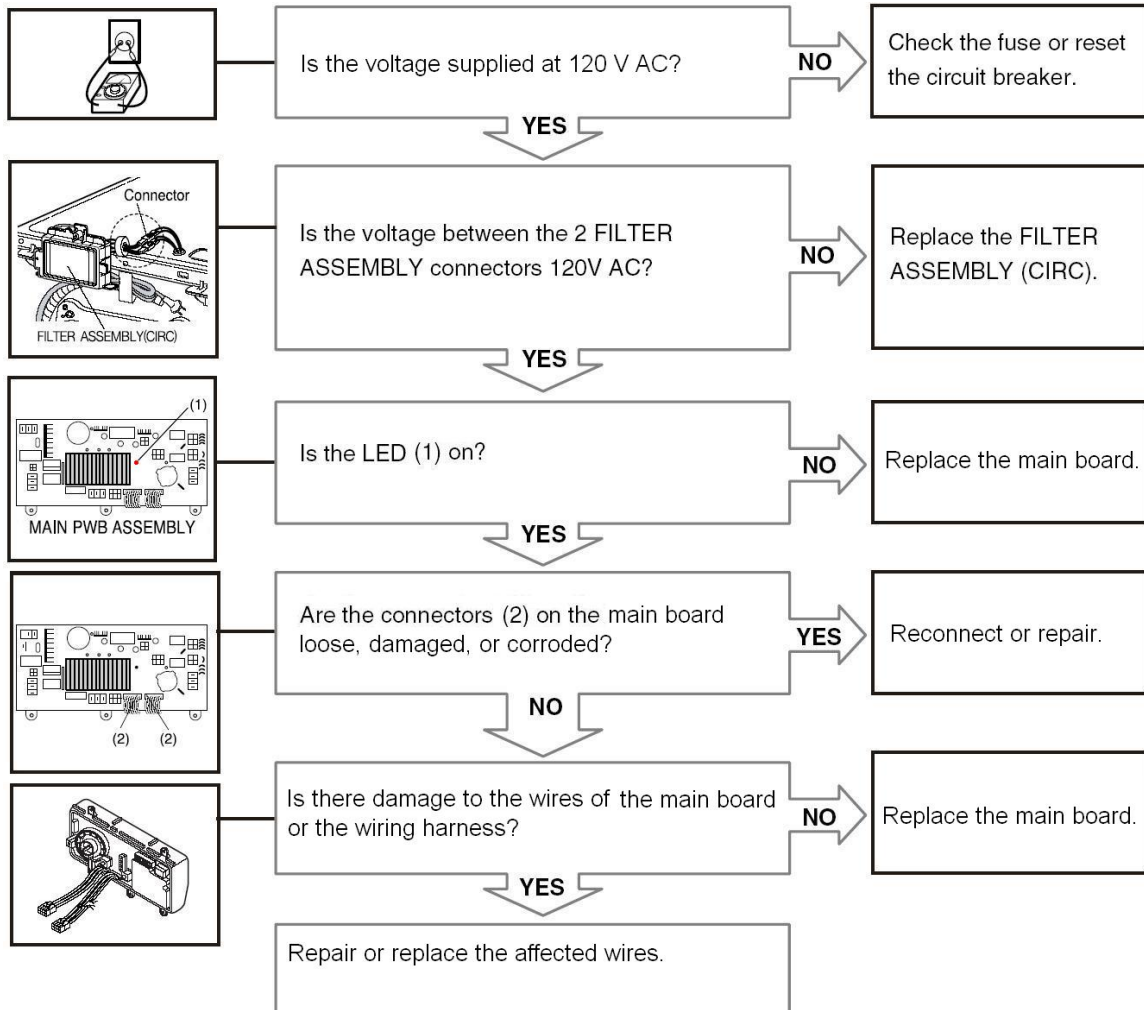

DIAGNOSIS/TROUBLESHOOTING (continued)

VIBRATION and NOISE IN SPIN CYCLE

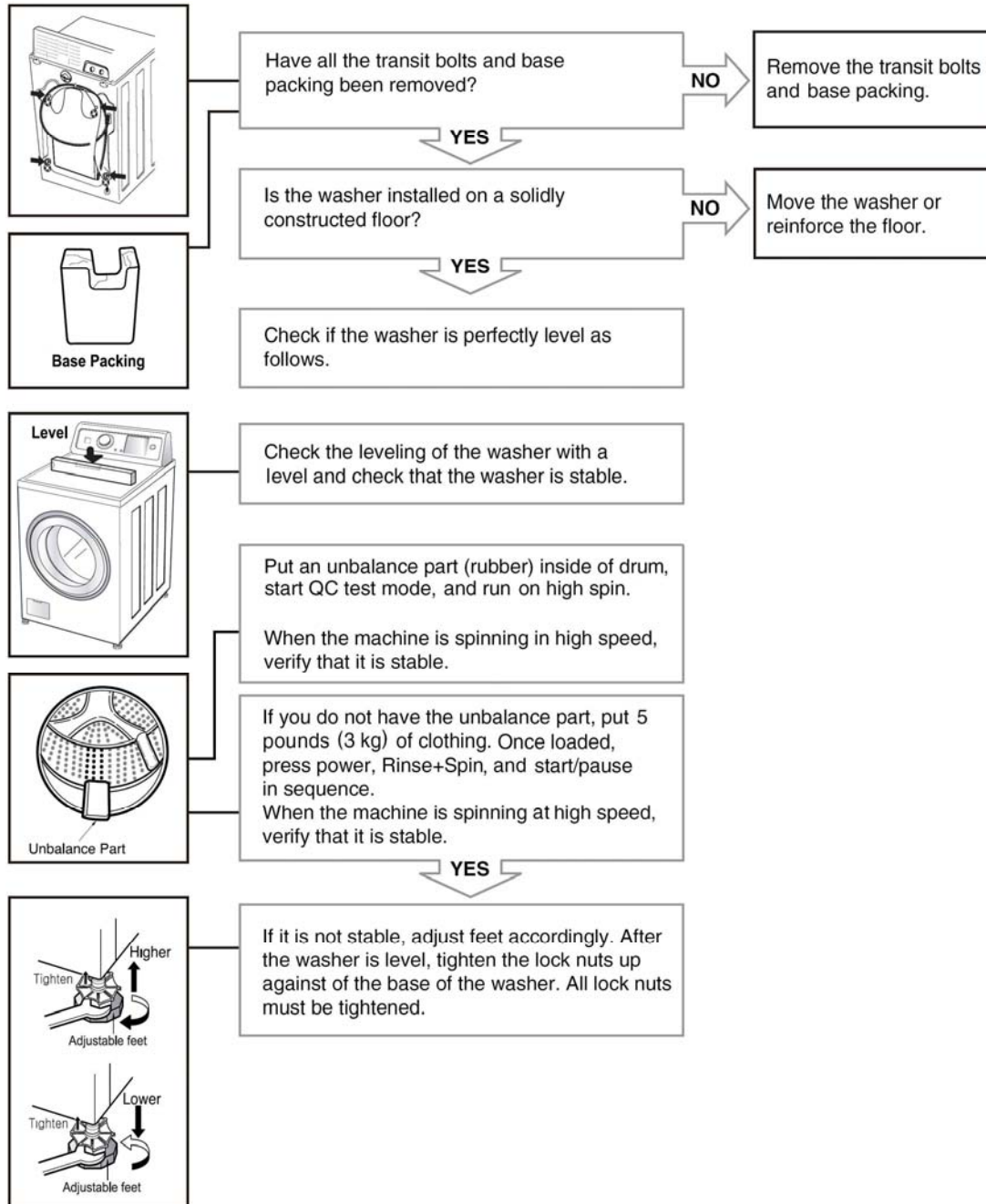

DIAGNOSIS/TROUBLESHOOTING (continued)

NO WATER SUPPLY

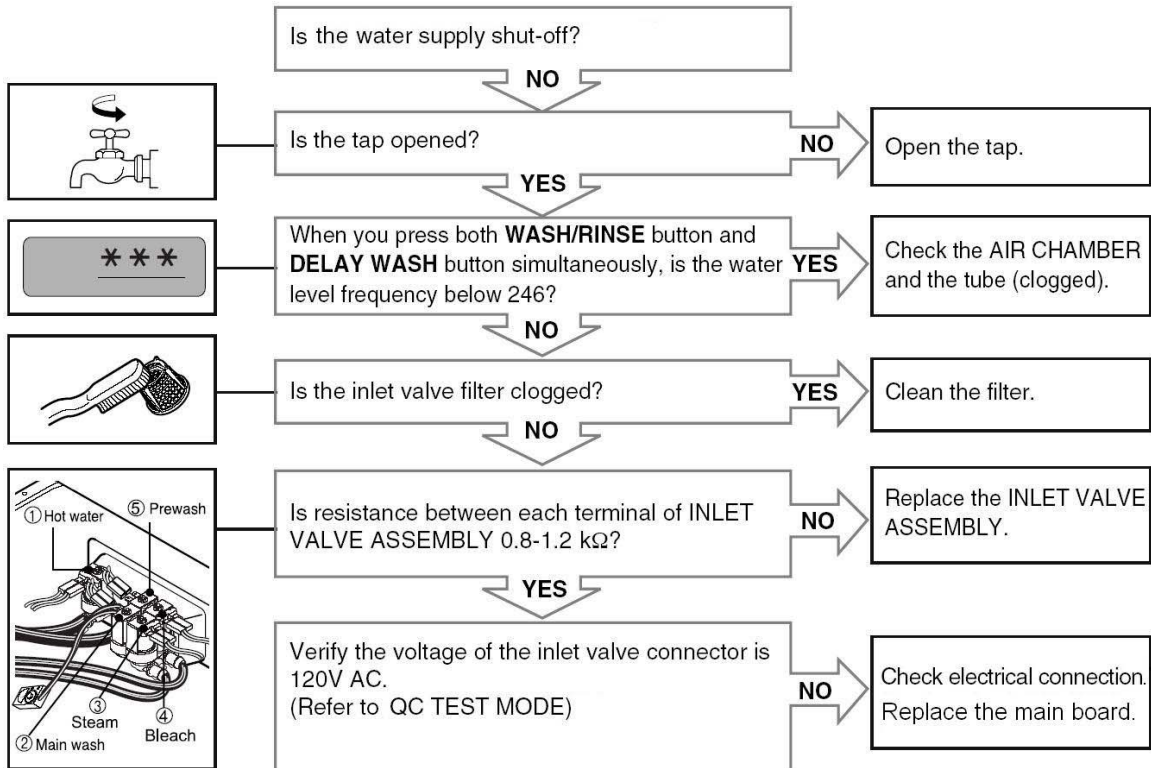

DETERGENT FAILS TO DISPENSE

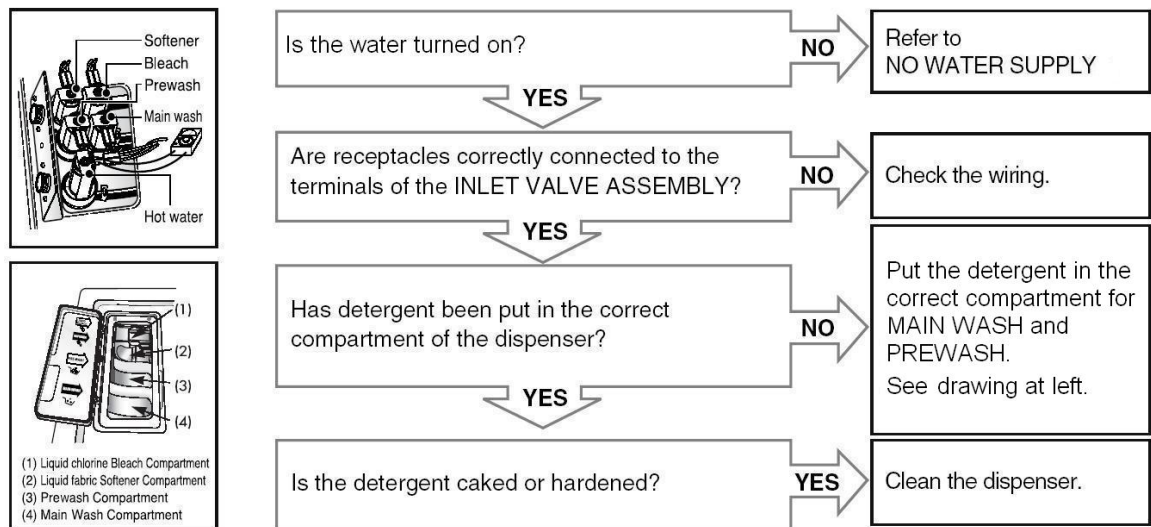

DIAGNOSIS/TROUBLESHOOTING (continued)

LIQUID DETERGENT / BLEACH / SOFTENER FAIL TO DISPENSE

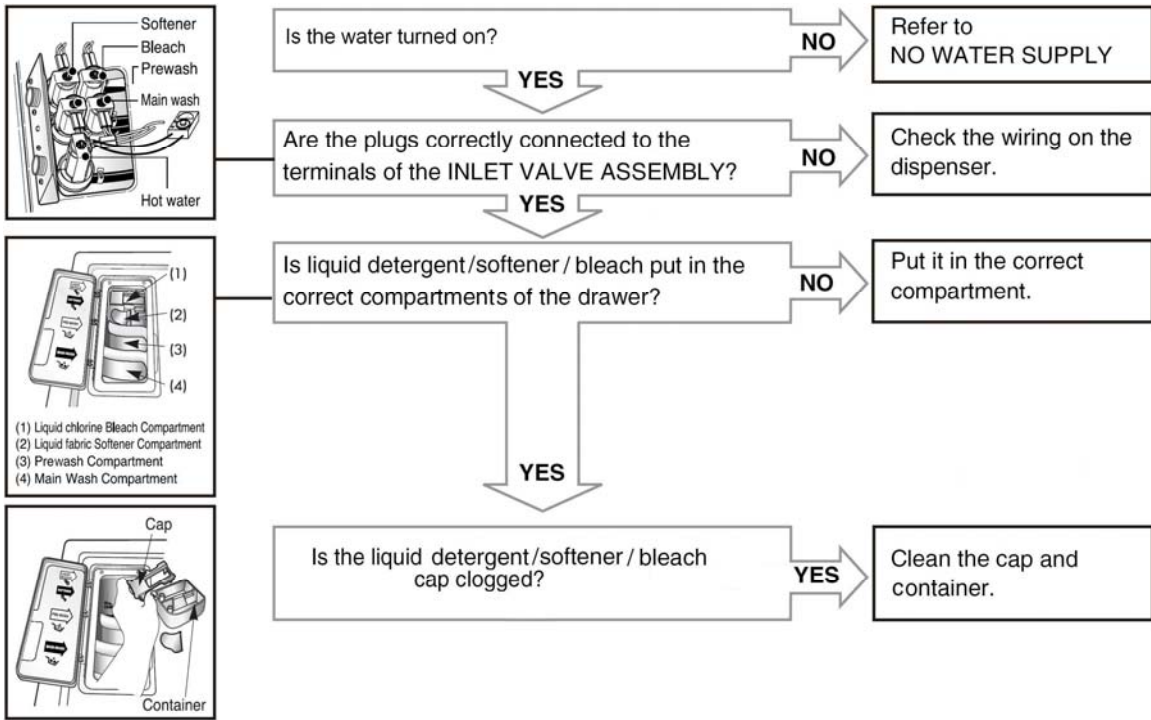

ABNORMAL SOUND

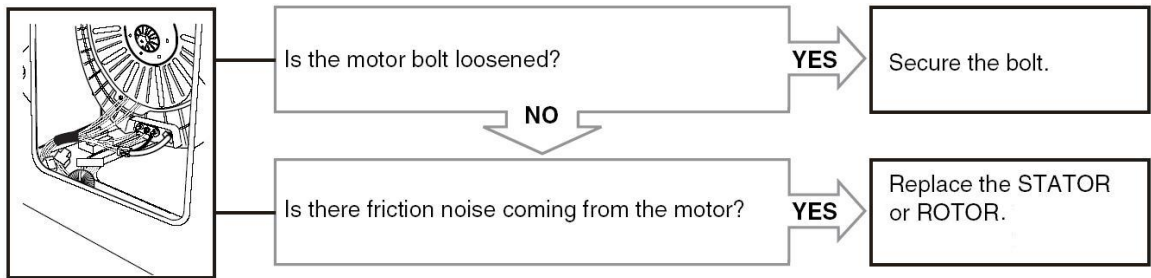

DIAGNOSIS/TROUBLESHOOTING (continued)

HEATING WITHOUT WATER

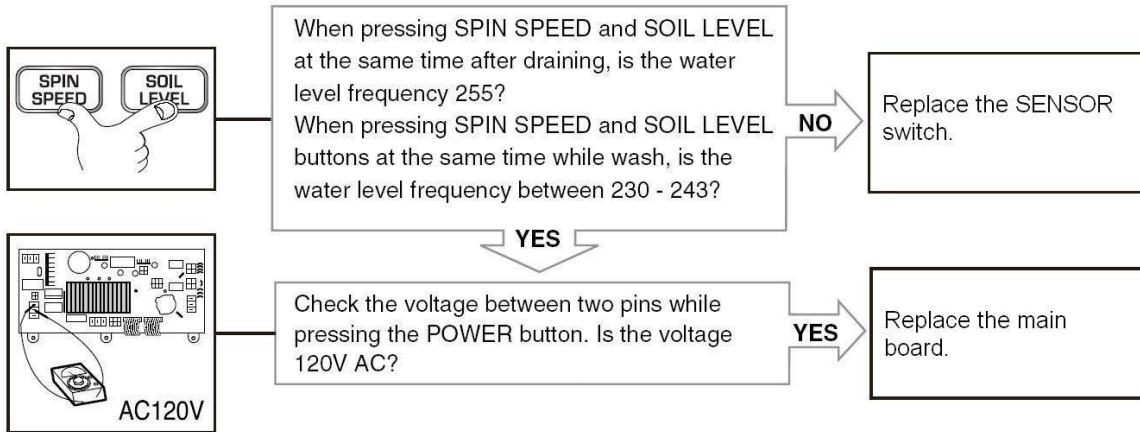

DRAIN MALFUNCTION

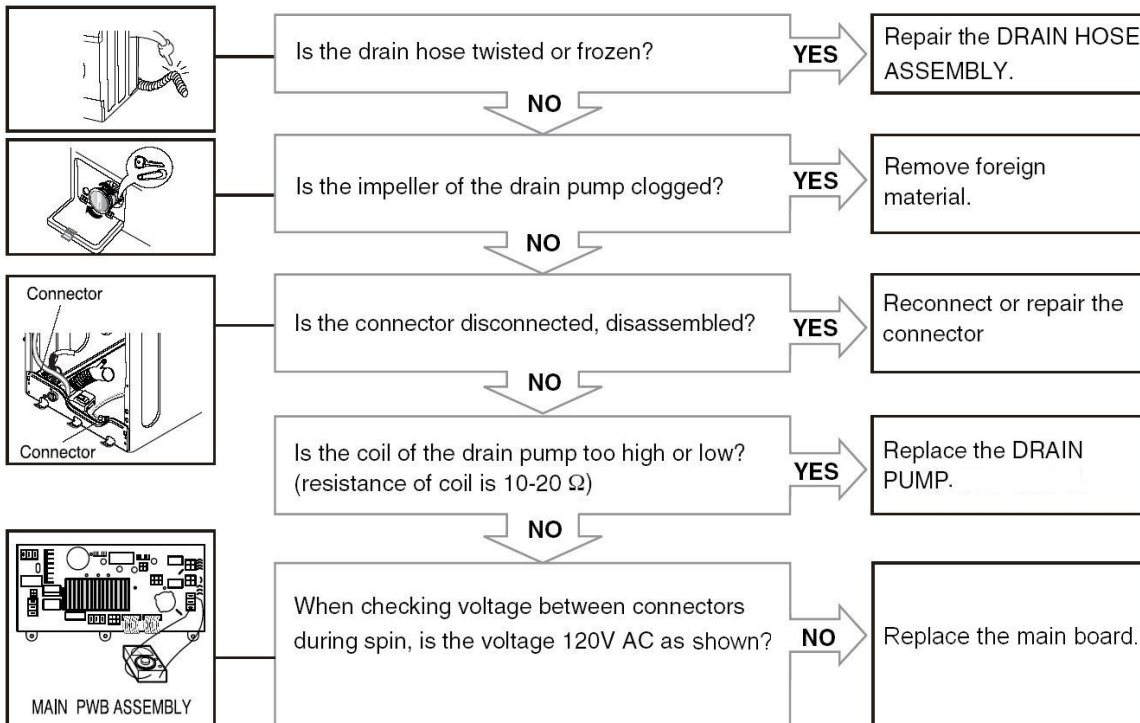

DIAGNOSIS/TROUBLESHOOTING (continued)

WASH HEATER MALFUNCTION

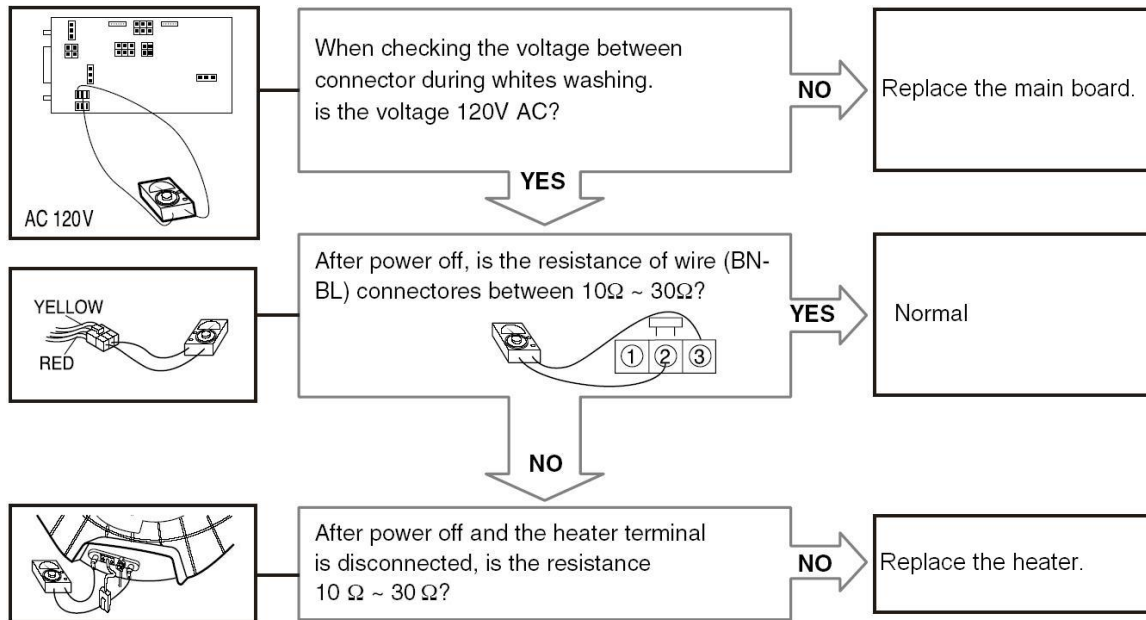

WASH HEATER OVERRUN

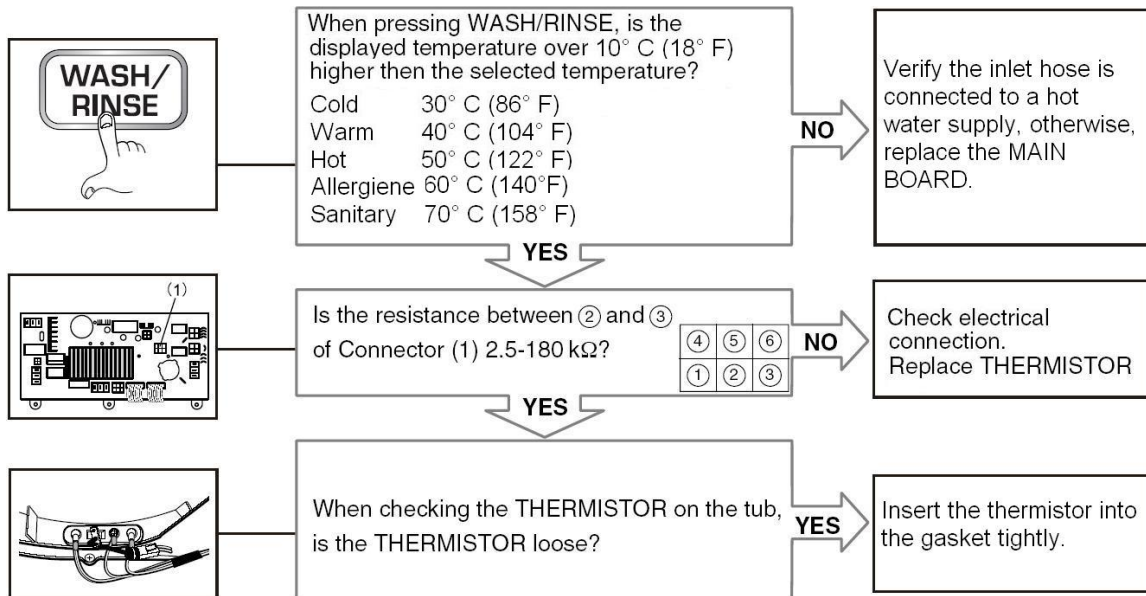

DIAGNOSIS/TROUBLESHOOTING (continued)

CIRCULATION FAILURE

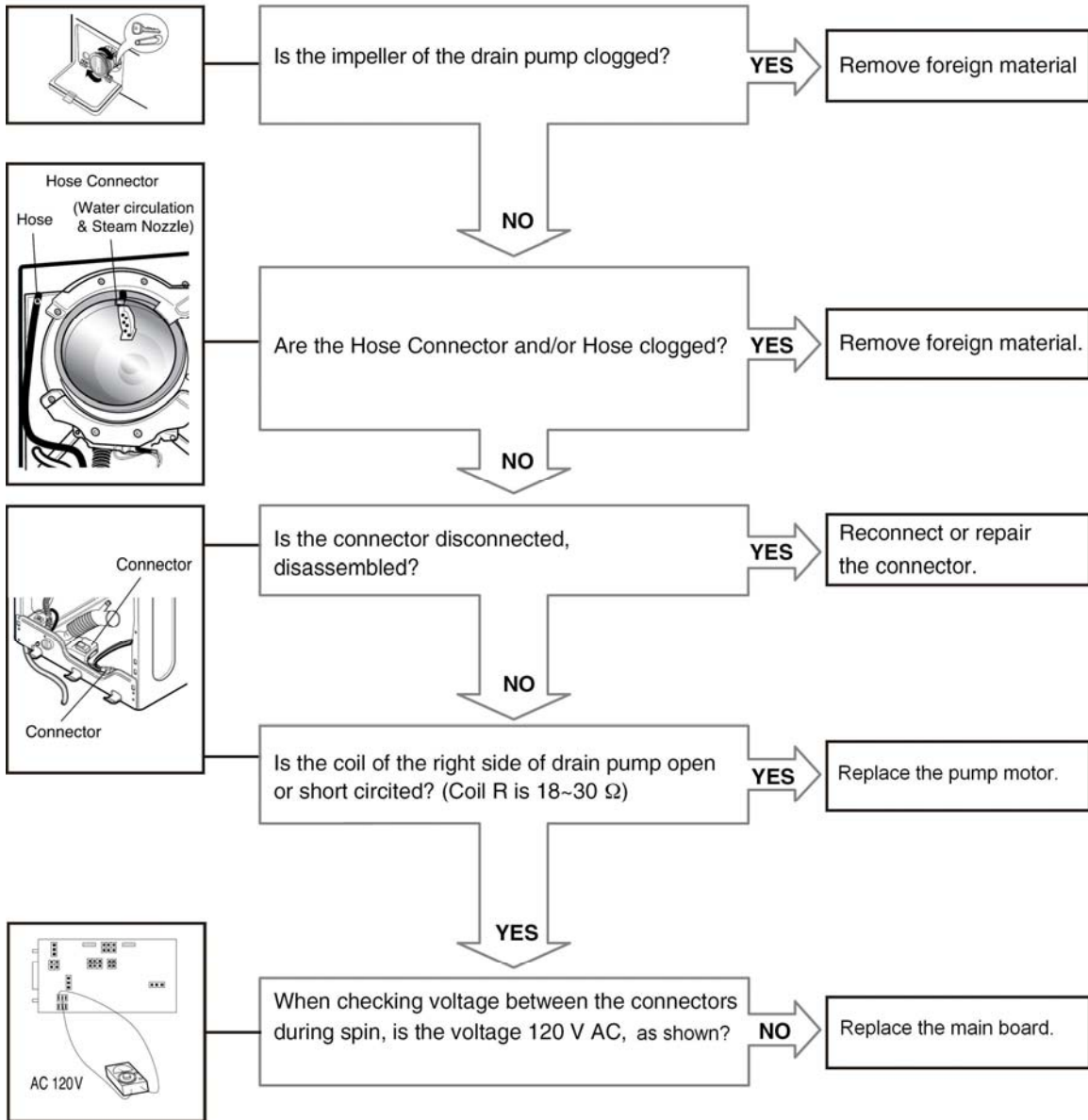

DIAGNOSIS/TROUBLESHOOTING (continued)

SPIN (MOTOR) MALFUNCTION

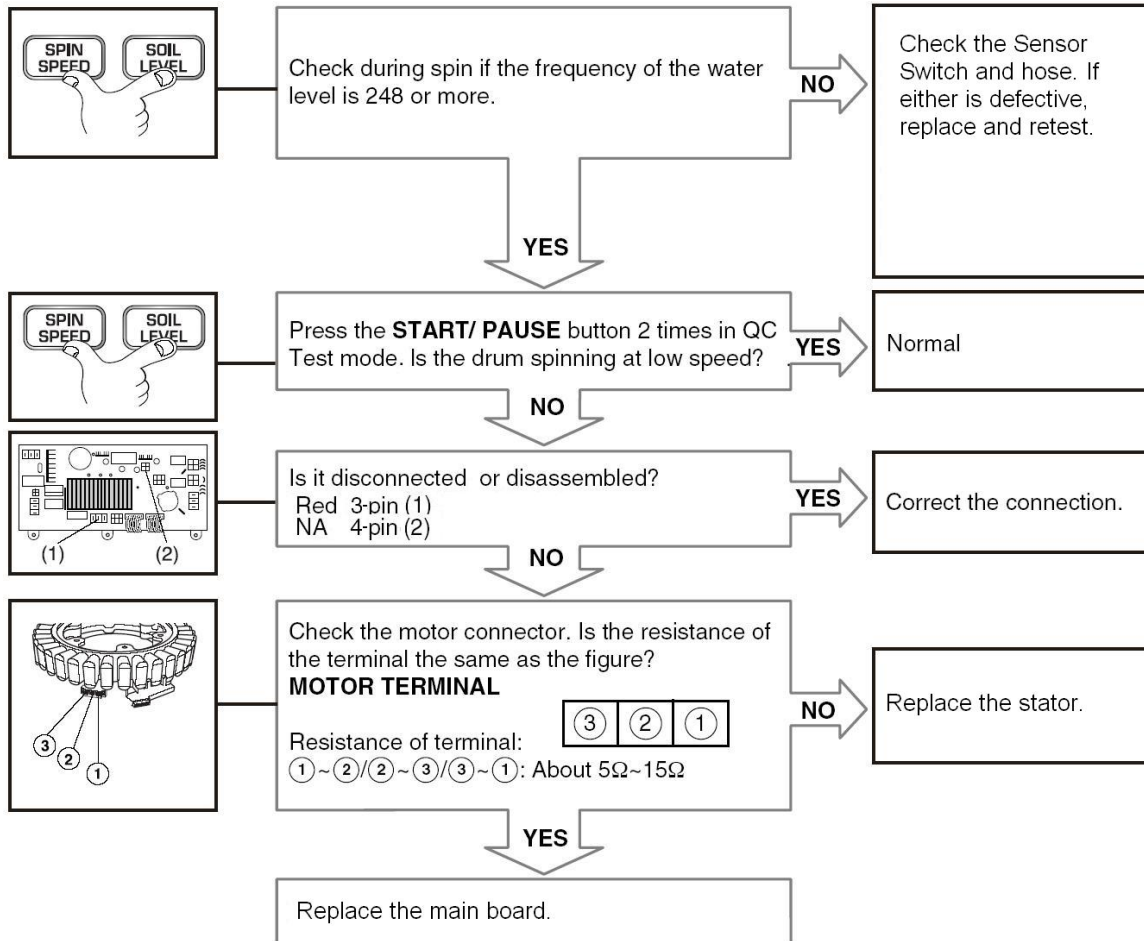

dE ERROR CODE

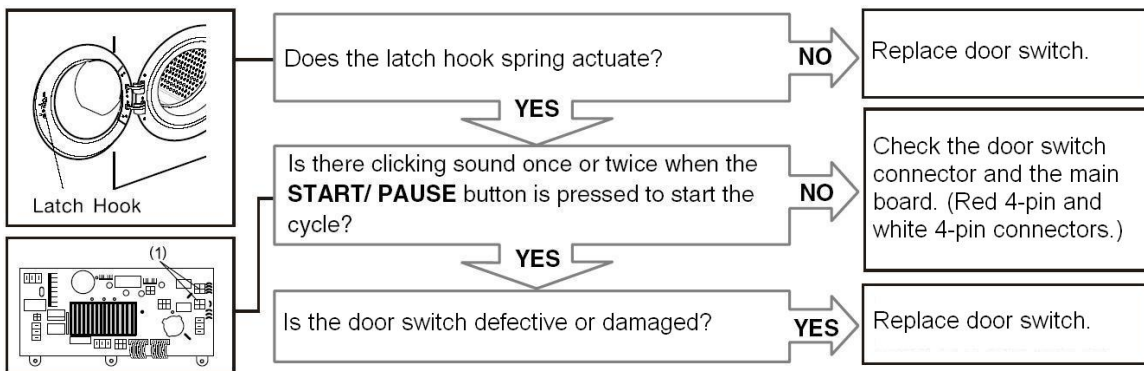

TIPS and TRICKS



HOSES

When replacing the large hoses, be sure to avoid getting the lip turned under the hose clamp. This will damage the hose and cause a leak. The large hoses have notches on the ends to index them on the connectors. Be sure the notch is pushed down all the way on the index boss. Use the ears on the hose ends to pull the hoses over the connections.

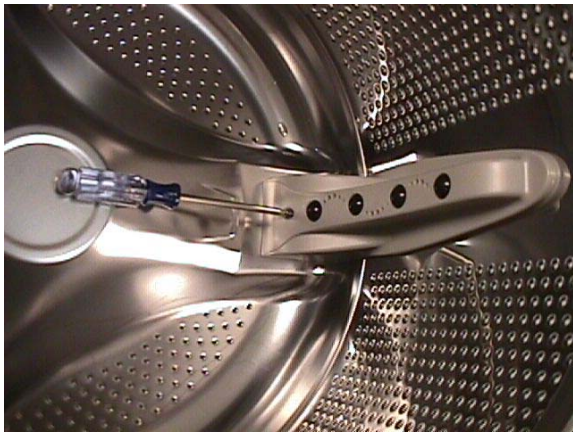

BAFFLES (Lifters)

You can replace the baffle and rollers without having to remove the drum. Unscrew the retaining screw at the back of the baffle. Slide it toward the front of the washer to remove it. You can unscrew the retainer inside the baffle to replace the roller balls.



MUSHROOM VALVE

Be sure the mushroom is in place before attaching the hose. If the stem is too long, it will contact the drum and make significant noise when the drum turns. The valves are not shown on the exploded view, but the locations have been numbered (X1 and X2) and the part numbers are shown on the parts list.

MAIN BOARD

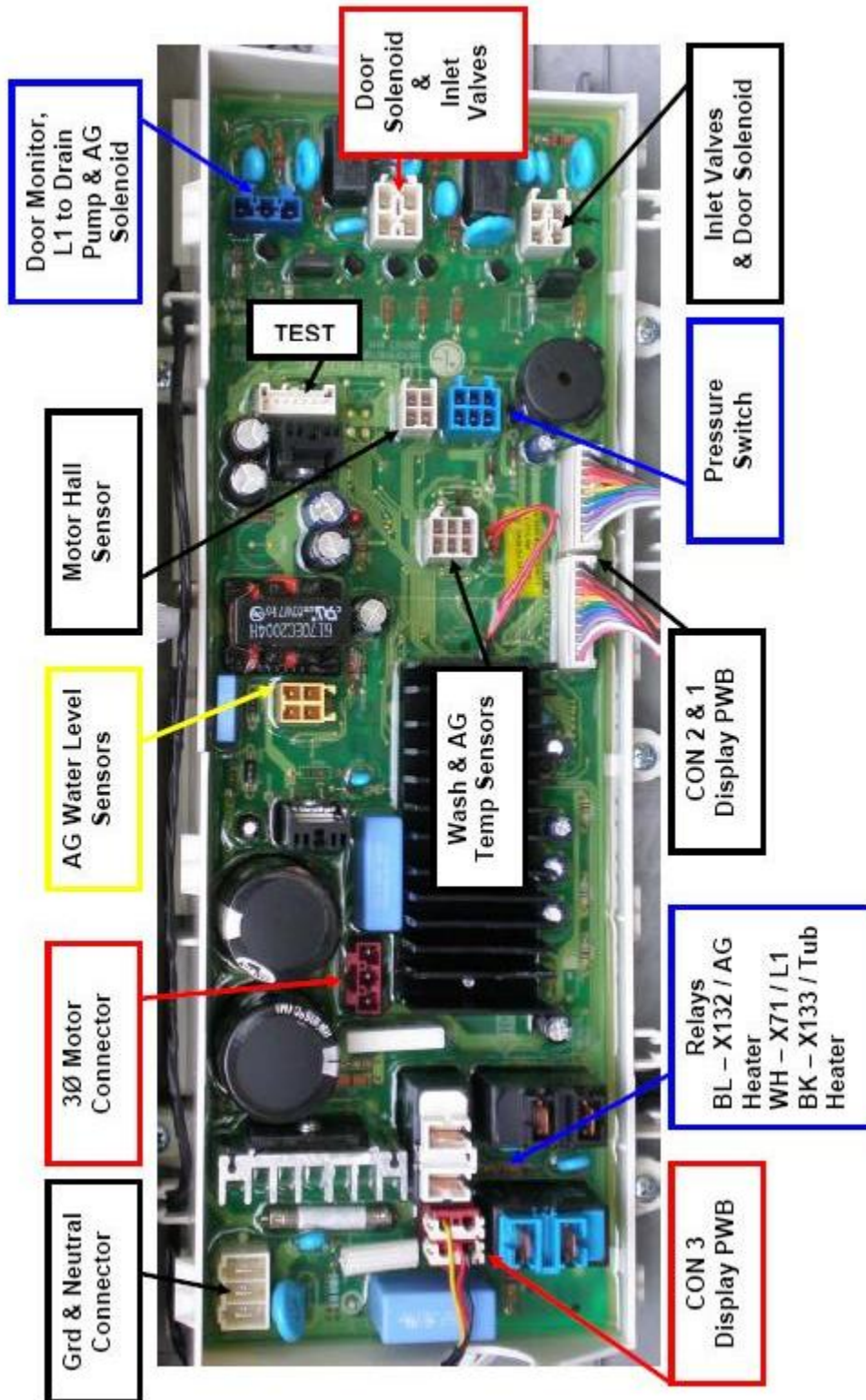

EXPLODED VIEW

CABINET ASSEMBLY

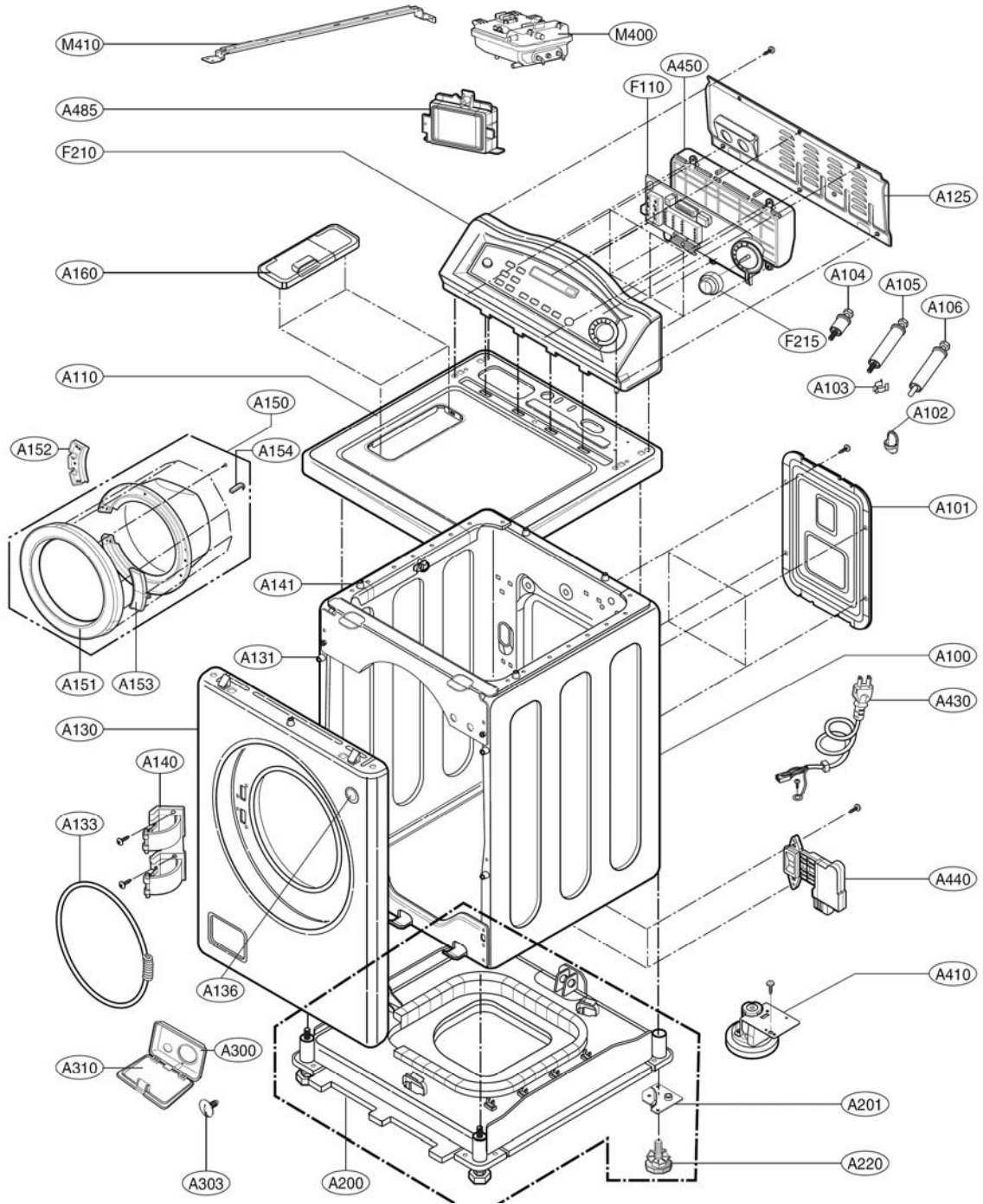

DRUM and TUB ASSEMBLY

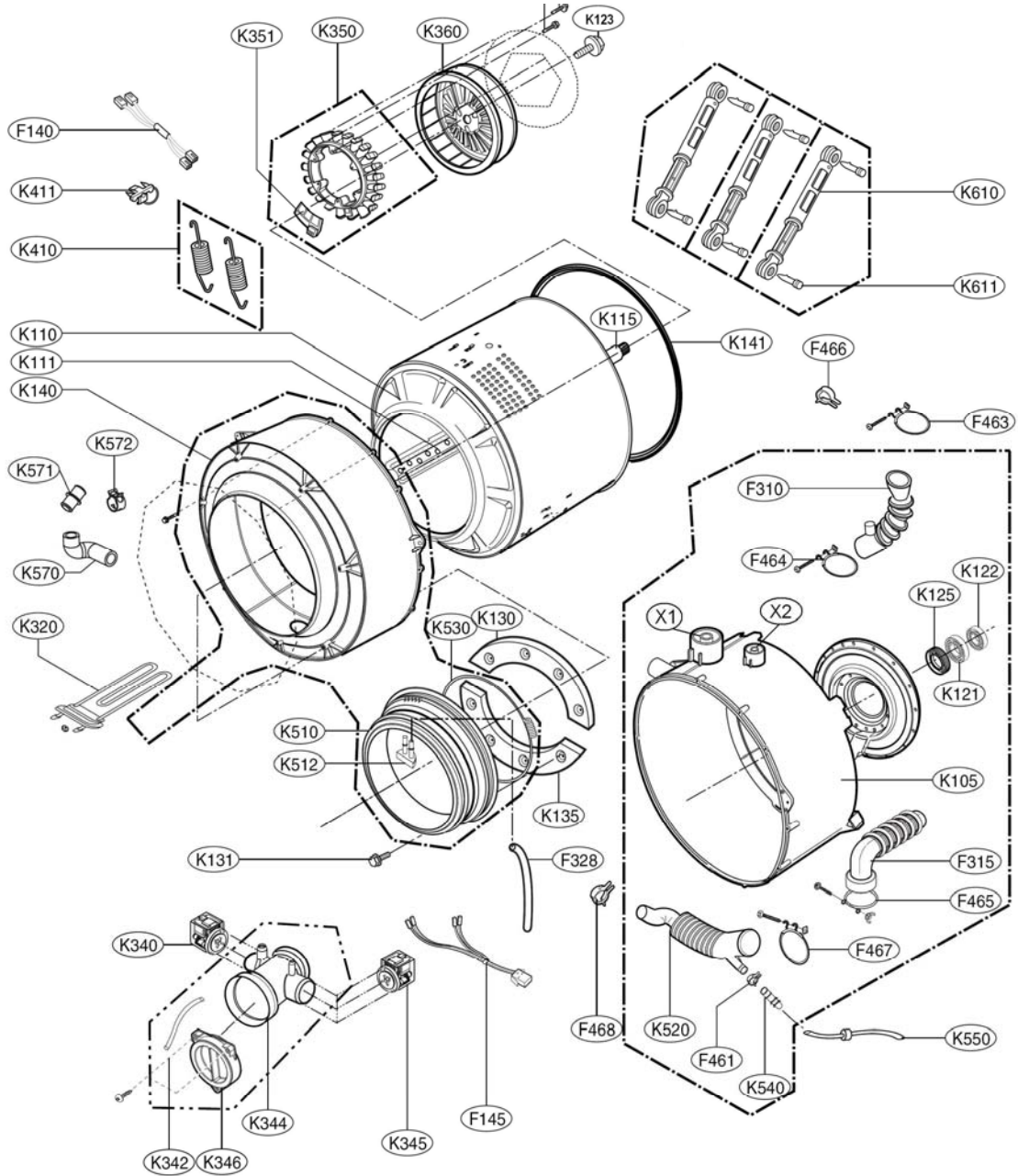

DISPENSER ASSEMBLY

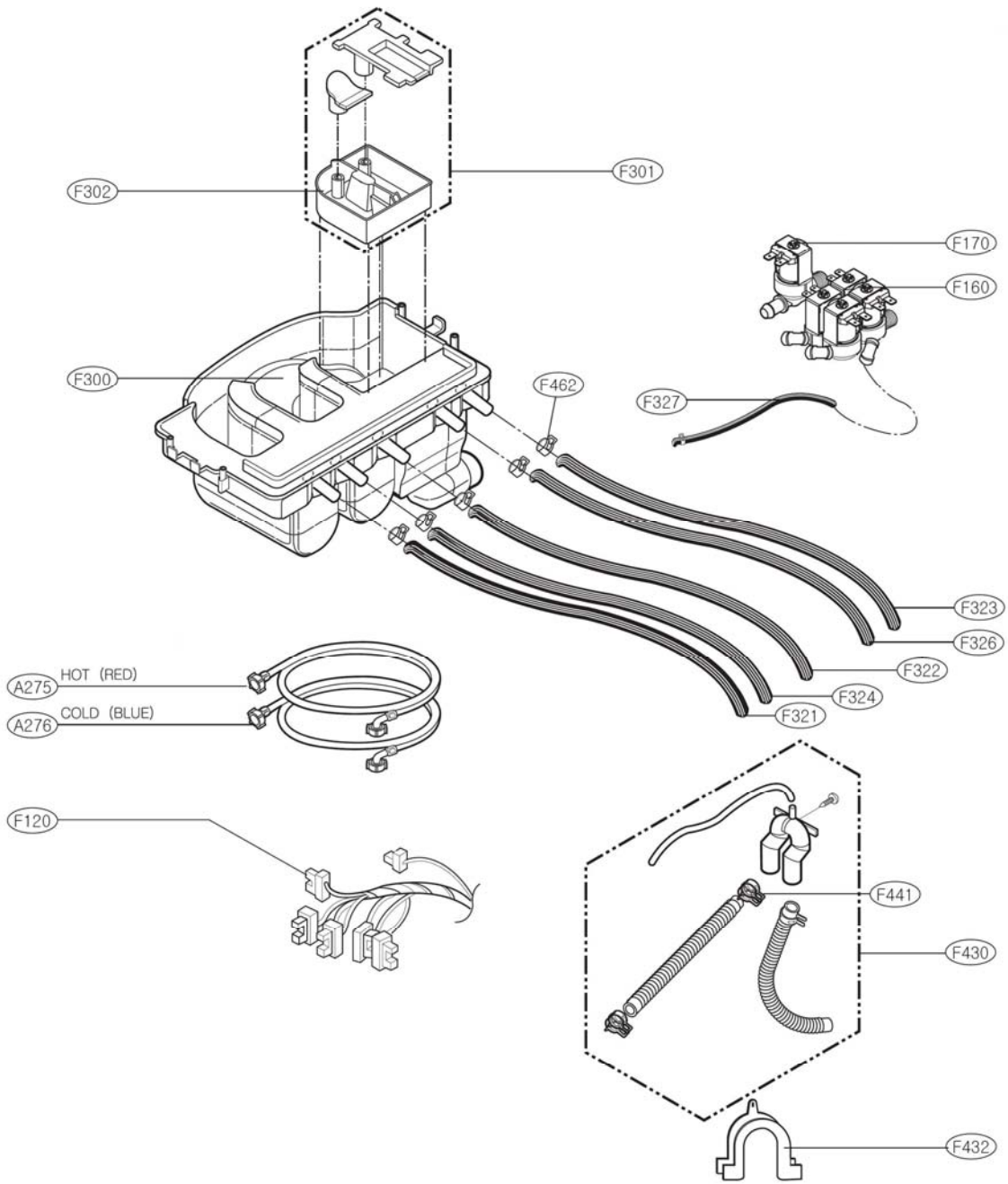

PARTS LIST

The parts list was correct at the time of publication, but change is inevitable. Always check GCSC for the current and accurate part numbers and availability.

Loc #	Part No	Description
*001	AFN30385127	Owner's Manual
*002	3890EZ3617A	Shipping carton
*003	3W20018D	Wrench
*004	MFL30599116	Service Manual
*009	MEG41552101	Door Lock Shim
A100	3091ER0001G	Cabinet, Gray
A101	3550ER1028A	Rear Cover
A102	4830ER3001A	Bushing, Drain pipe exit opening
A103	4930ER3014A	Holder
A104	4011FR3159E	Shipping Bolt, Short X 2
A105	4011FR3159D	Shipping Bolt, Long X 1
A106	4011FR3159J	Shipping Bolt, Long, with cord clip X 1
A110	3457ER1002M	Top Cover
A125	3210ER1306A	Frame, Rear
A130	3550ER0005E	Front Cover, Cabinet
A131	AEJ33026601	Holder Assembly
A133	ACA32390101	Clamp, Outer Gasket Spring
A136	3847ER3001A	Name Plate Assembly
A140	4775ER2001A	Hinge Assembly
A141	AEJ33026601	Holder Assembly
A150	3581ER0001Q	Door Assembly
A151	3212ER0003B	Frame, Door (Outer)
A152	3212ER1011A	Frame, Door (Inner)
A153	3650EL2001B	Handle
A154	4026ER4004B	Locker, Hook
A160	3523ER1001L	Lid Assembly, Gray
A200	3041ER0001C	Base Assembly, Cabinet
A201	4810ER3006A	Bracket, Base
A220	4779ER3002A	Leg Assembly
A275	5215FD3715J	Hose, Inlet Hot (Red) (90°C)
A276	5215FD3715K	Hose, Inlet Cold (Blue) (25°C)
A300	3110ER2002C	Case
A303	5006ER3009A	Cap, Drain Hose Plug
A310	5006ER3006G	Cap, Filter Access Cover
A410	6600FA1704X	Switch Assembly, Pressure
A430	EAD49973501	Power Cord Assembly

Loc #	Part No	Description
A440	6601ER1004C	Switch Assembly, Locker
A450	EBR42923401	Main Board
A485	6201EC1006A	Filter (Noise) Assembly
F110	6871EC2123J	PCB Assembly, Display
F120	6877ER1015P	Harness, Multi
F140	6877ER1016F	Harness, Multi
F145	6877ER3003B	Harness, Single
F160	5221EA1009B	Valve Assembly, Inlet Cold, 5-way
F170	5220FR2006H	Valve Assembly, Inlet Hot 1-way
F210	3721EL1013X	Control Panel Assembly, Gray
F215	4940ER3014A	Knob, Rotary (Cycle Knob)
F300	4924ER1006B	Dispenser
F301	3891ER2002A	Box Assembly, Bleach/Softener
F302	3890ER2002A	Box, Bleach/Softener
F310	4738ER2001A	Bellows, Dispenser to tub
F315	4738ER2002A	Bellows, Tub to air vent
F321	5214FR4125T	Hose, Inlet Cold to Main Wash
F322	5214FR4125Q	Hose, Inlet Cold to Pre-Wash
F323	5214FR4125D	Hose, Inlet Cold to Bleach
F324	5214FR4125P	Hose, Inlet Hot to Main Wash
F326	5214FR4125R	Hose, Inlet Cold to Softener
F327	5214FR4125Y	Hose, Cold to Steam Generator
F328	5214FR4006Z	Hose, Recirculation Pump to Tub)
F430	5215ER2002F	Hose Assembly, Drain
F432	3W50712A	Drain Hanger Assembly
F441	4861FR3068C	Clamp
F461	4861FR3068E	Clamp
F462	4861FR3068A	Clamp
F463	4860FR3092D	Clamp
F464	4860FR3092C	Clamp
F465	4860FR3092H	Clamp
F466	4861FR3068M	Clamp
F467	4860FR3092C	Clamp
F468	4861FR3068E	Clamp
K105	3045ER0048C	Tub, Outer (Back half)
K110	3045ER1017A	Drum (Inner)
K111	4433ER1005A	Lifter Assembly
K115	4434ER0002A	Spider
K121	4280FR4048N	Bearing, Ball (Inner)

Loc #	Part No	Description
K122	4280FR4048J	Bearing, Ball (Outer)
K123	4040FR4051C	Bolt Assembly
K125	4036ER2004A	Gasket
K130	4866ER0007A	Balance Weight (Top)
K131	1SZZER4002A	Screw, Custom
K135	4866ER0004A	Balance Weight (Bottom)
K140	3551ER0026J	Tub, Outer (Front half)
K141	4036ER4001B	Gasket (Between tub halves)
K143	4011FA4353B	Bolt, Common
K320	AEG33121501	Heater Assembly
K340	4681EA2001D	AC Pump Motor (Drain Pump)
K342	5214FR4006L	Hose, Connector
K344	3108ER1001A	Pump and Filter Housing
K345	4681EA2002D	AC Pump Motor (Recirculating Pump)
K346	383EER2001A	Parts Assembly
K350	4417EA1002H	Stator Assembly
K351	6501KW2002A	Sensor Assembly
K360	4413ER1003A	Rotor Assembly
K410	4970FR2084N	Spring, Hinge
K411	4930FR3040A	Holder
K510	4986ER0001E	Gasket
K512	4932ER3007A	Connector, Nozzle
K520	4738ER1002A	Bellows
K530	4861ER2001F	Clamp, Outer Gasket Spring
K540	3504ER3002A	Chamber, Air
K550	5214FR4125N	Hose, Tub to Pressure Switch
K570	5214FR4058Y	Hose, Gasket Drain Connector
K571	4932ER4007B	Hose, Gasket to tub drain
K572	4861FR3068A	Clamp
K610	383EER3001E	Damper
K611	4774FR3118B	Damper Hinge Pin
M400	3111ER1001F	Steam Generator Assembly
M410	3210ER1318A	Frame, Body Steam Gen. Support
X1	4769ER4002A	Mushroom valve (fill tube) (not pictured)
X2	4769ER4001A	Mushroom valve (vent tube) (not pictured)

Loc #	Part No	Description
	383EER4001A	GASKET PLIER (SPECIAL TOOL)
	383EER4003A	DAMPER PLIER (SPECIAL TOOL)
	383EER4004A	GASKET PLIER (SPECIAL TOOL)
	5214FR3018D	DRAIN HOSE EXTENSION (5 FEET)

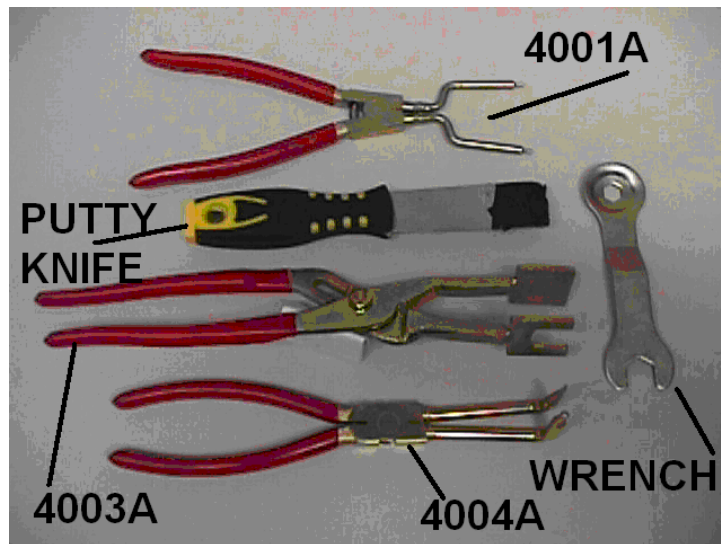

SERIAL NUMBER IDENTIFICATION

The serial number is unique to each product. It gives information concerning the time and place of manufacture. The serial number is required to be paid for warranty service and to get the correct part in the event a running production change was made. Some models may have four (4) letters instead of two (2) for the product code number. The third and fourth letters are significant only to the manufacturing facility. This chart will help you decode the serial number.

[Example] 801KW3400251

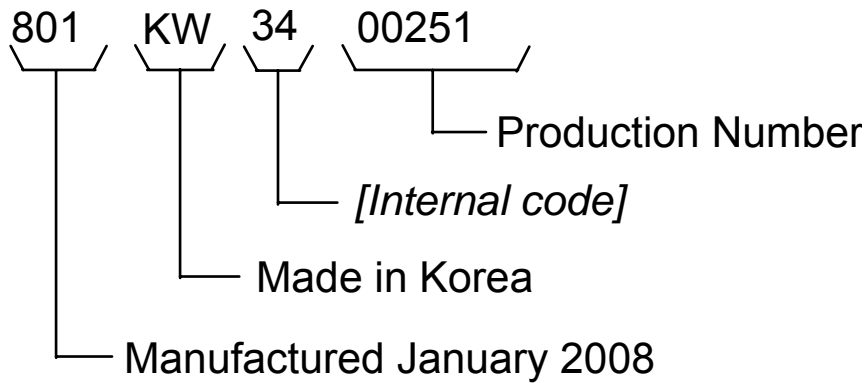

Newer Style With Barcode



New Serial Code (ETA Mid 2008)

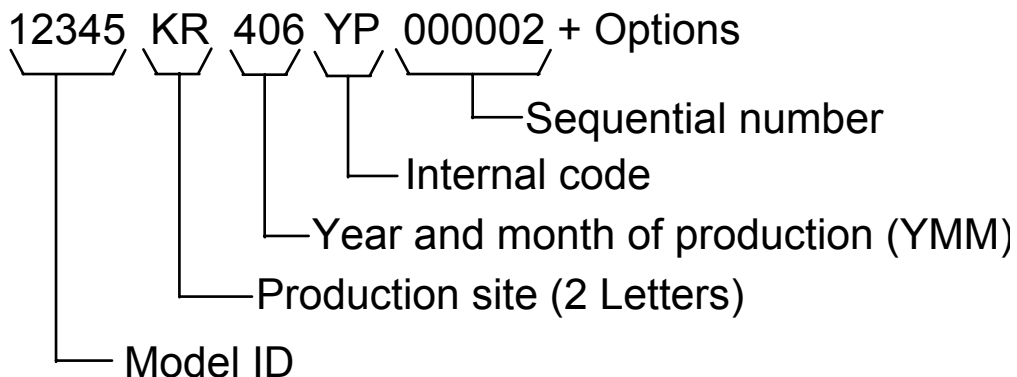

OHM'S LAW and WATT'S LAW

P = WATTS

Watts = Volts² x Ohms
 Watts = Amperes² x Ohms
 Watts = Volts x Amperes

I = AMPERES

Amperes = Volts / Ohms
 Amperes = Watts / Volts
 Amperes = $\sqrt{\text{Watts} / \text{Ohms}}$

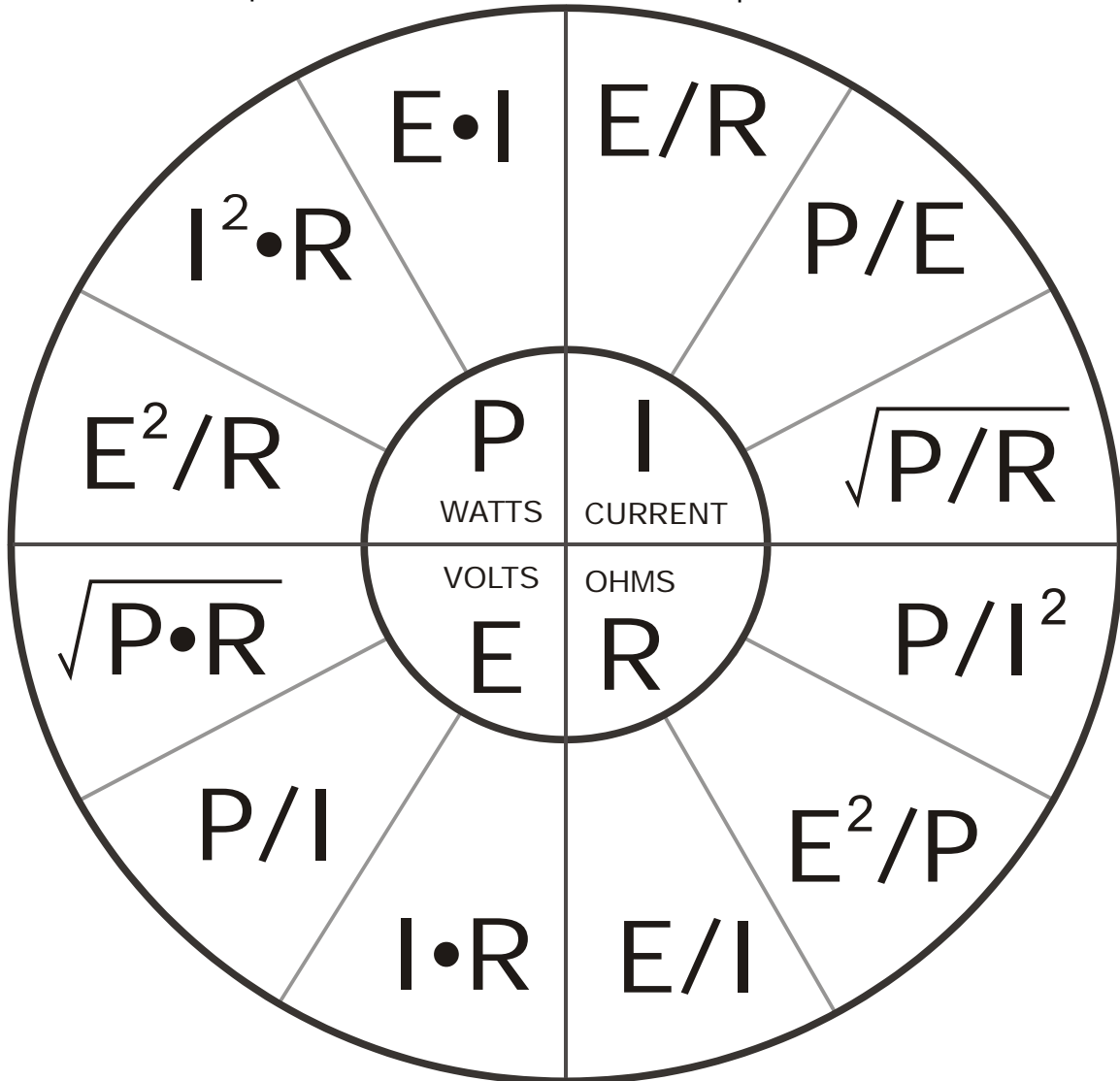

E = VOLTS

Volts = $\sqrt{\text{Watts} \times \text{Ohms}}$
 Volts = Watts / Amperes
 Volts = Amperes x Ohms

R = OHMS

Ohms = Volts / Amperes
 Ohms = Volts² / Watts
 Ohms = Watts / Amperes²

CONVERSION INFORMATION

FORMULAE

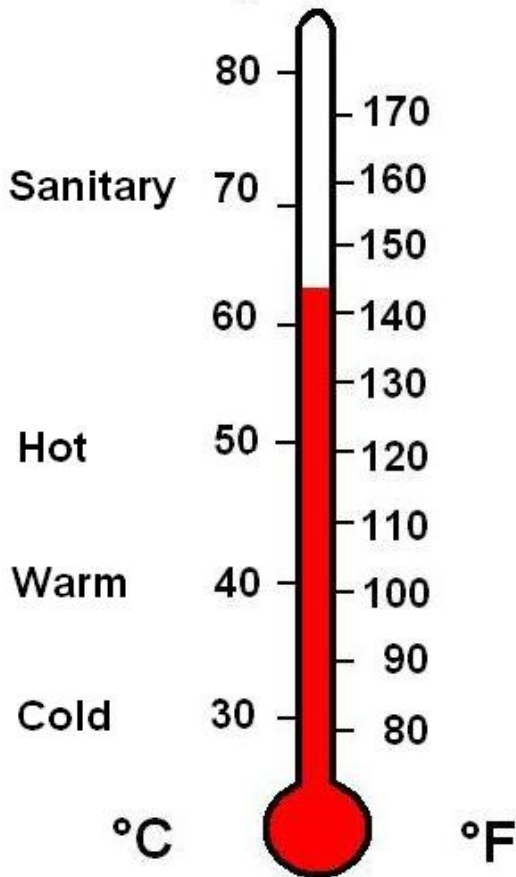

$$^{\circ}\text{F} = (9/5) ^{\circ}\text{C} + 32$$

$$^{\circ}\text{C} = (5/9) \times (^{\circ}\text{F} - 32)$$

WASH TEMPERATURES

Sanitary	158° F	(70° C)
Allergiene	140° F	(60° C)
Hot	122° F	(50° C)
Warm	104° F	(40° C)
Cold	86° F	(30° C)
Tap Cold	whatever is in the pipe	

SPIN SPEEDS

Extra High	1,150 rpm
High	1,010 rpm
Normal	1,000 rpm
Low	960 rpm
Gentle	400 rpm

STAIN CYCLE

Adds cycle time and increases wash temperature

SOIL LEVEL

Increases or decreases total cycle times (wash and rinse)
 Heavy 1:22
 Normal 0:52
 Low 0:47

SERVICE BULLETINS

Service Bulletin



No.	WWM20080108
Date	2008-03-05

Model	Factory	Factory Model	Suffix	Model No.	Factory	Factory Model	Suffix	Model No.
	EKHQ	F1201FD		ABWEEUS	WM2455HW	EKHQ	F1201FD1	APGEEUS
EKHQ	F1305FDM		ASTEELUS	WM0001HTMA	EKHQ	F1305FDM	ASTEELUS	WM0001HTMA
EKHQ	WD-10210BD		ABWEEUS	WM2032HW	EKHQ	WD-10212BD	ABWEEUS	WM0532HW
EKHQ	WD-10215BD		ATTEELUS	WM2032HS	EKHQ	WD-10272BD	ABWEEUS	WM2075CW
EKHQ	WD-10410BD		ABWEEUS	WM2042CW	EKHQ	WD-10460BD	ABWEEUS	CW2079CWD
EKHQ	WD-10465BD		ABWEEUS	CW2079CWN	EKHQ	WD-10580BD	ABWEEUS	WM2016CW
EKHQ	WD-11270RD		ABWEEUS	WM3677HW	EKHQ	WD-11581BD	ABWEEUS	WM2233HW
EKHQ	WD-11586BD		ATTEELUS	WM2233HS	EKHQ	WD-12210BD	ABWEEUS	WM2432HW
EKHQ	WD-12210RD		ABWEEUS	WM3632HW	EKHQ	WD-12272BD	ABWEEUS	WM2277HW
EKHQ	WD-12275BD		ABPEEUS	WM2277HB	EKHQ	WD-12276BD	ATTEELUS	WM2277HS
EKHQ	WD-12410BD		ABWFEUS	WM2442HW	EKHQ	WD-12412BD	ABWFEUS	WM0642HW
EKHQ	WD-12433BDA		ABWEEUS	WM2487HWMA	EKHQ	WD-12433BDA	ABWEEUS	WM2487HWMA
EKHQ	WD-12433BDM		ABWEEUS	WM2487HWM	EKHQ	WD-12439BDA	ACREEUS	WM2487HRMA
EKHQ	WD-12439BDA		ACREEUS	WM2487HRMA	EKHQ	WD-12439BDM	ACREEUS	WM2487HRM
EKHQ	WD-12520BDM		ABWEEUS	WM2496HWM	EKHQ	WD-12526BDM	ATTEELUS	WM2496HSM
EKHQ	WD-13270BDM		ABWEECI	WM2677HWM	EKHQ	WD-13275BDM	ABPEEUS	WM2677HBM
EKHQ	WD-13276BDM		ATTEELUS	WM2677HSM	EKHQ	WD-13513BDA	ABWEEUS	WM2688HWMA
EKHQ	WD-13513BDA		ABWEEUS	WM2688HWMA	EKHQ	WD-13513BDM	ABWEEUS	WM2688HWM
EKHQ	WD-13517BDA		ANBEEUS	WM2688HNMA	EKHQ	WD-13517BDA	ANBEEUS	WM2688HNMA
EKHQ	WD-13517BDM		ANBEEUS	WM2688HNM	EKHQ	WD-90210BD	ABWEEUS	WM1832CW
Buyer	Buyer Name	Buyer Code	Buyer Name	Buyer Code	Buyer Name	Buyer Code		
	LGEUS	US000001	LGEAI	US000002				
EFFECTIVE DATE	2007-09-30	EFFECTIVE FROM (SERIAL NO.)		All Production Lots since 20 Sep. 2007 (709KW...)				
Subject	New Door Gasket (Boot) Application for odor reduction							

No.	Loc No.	Before Change		After Change		Note	K-Code	Remark
		Part No	DESC./SPEC.	Part No	DESC./SPEC.			

Service Bulletin

Reason Of Change

A drain hole has been added to the gasket (boot) of some lots produced since September, 2007.

Gaskets (boots) with the drain hole do not appear in washers produced in August, 2007 or earlier.

Install a gasket without drain hole on washers that were produced in August, 2007 or earlier. For washers produced since September, 2007, it is necessary to check and see if they were manufactured with a new gasket (with the drain hole) or old gasket (without the drain hole).

For Model and Part Number application details, see the attached pdf file.

NOTES:

1. Part Numbers have been changed only on new gaskets. They have not been changed on outer tubs or balance weights.

2. To Replace:

a. GASKET only - Check manufacture date and, on newer models, inspect the existing gasket. See the attached

file for the correct model and part number information.

b. TUB COVER (outer Tub) only - Replace OLD Tub Covers with new Tub Cover Assemblies. Replace NEW Tub

Covers with new Tub Covers (not assemblies). The existing inventory of old Tub Covers may be used as replacements for old Tub Covers only.

c. BALANCE WEIGHT - NEW weights can be used on ALL products. OLD weights CAN NOT be used on washers produced after August, 2007.

d. TUB COVER ASSEMBLY - NEW Tub Cover Assemblies can be used on ALL washing machines covered by this bulletin.

WWM20080108 Door Gasket Drain.pdf

**** FILE THIS SERVICE BULLETIN WITH YOUR SERVICE MANUAL**

Service Bulletin

NOTE (**) : INTERCHANGEABILITY CODE		KEY-WORD CODE						
	Parts Set							
A	<table style="width: 100%; border: none;"> <tr> <td style="width: 50%;">Original</td> <td style="width: 10%; text-align: center;">↗</td> <td style="width: 5%;">Early</td> </tr> <tr> <td>New</td> <td style="text-align: center;">↘</td> <td>Late</td> </tr> </table>	Original	↗	Early	New	↘	Late	Original or new parts may be used in early or late production sets. Use original parts until exhausted, then stock new parts.
Original	↗	Early						
New	↘	Late						
B	<table style="width: 100%; border: none;"> <tr> <td style="width: 50%;">Original</td> <td style="width: 10%; text-align: center;">→</td> <td style="width: 5%;">Early</td> </tr> <tr> <td>New</td> <td style="text-align: center;">↘</td> <td>Late</td> </tr> </table>	Original	→	Early	New	↘	Late	Original parts may be used in early production sets only. New parts may be used in early or late production sets. Use original parts where possible, then stock new parts.
Original	→	Early						
New	↘	Late						
C	<table style="width: 100%; border: none;"> <tr> <td style="width: 50%;">Original</td> <td style="width: 10%; text-align: center;">↗</td> <td style="width: 5%;">Early</td> </tr> <tr> <td>New</td> <td style="text-align: center;">→</td> <td>Late</td> </tr> </table>	Original	↗	Early	New	→	Late	New parts only may be used in early or late production sets. Stock new parts.
Original	↗	Early						
New	→	Late						
D	<table style="width: 100%; border: none;"> <tr> <td style="width: 50%;">Original</td> <td style="width: 10%; text-align: center;">→</td> <td style="width: 5%;">Early</td> </tr> <tr> <td>New</td> <td style="text-align: center;">→</td> <td>Late</td> </tr> </table>	Original	→	Early	New	→	Late	Original parts only may be used in early production sets. New parts may be used in late production sets only. Stock original and new parts.
Original	→	Early						
New	→	Late						

CHIEF ENGINEER : *approved*
 Factory.

SERVICE BULLETIN

WASHER

LG Electronics Inc.

Date of issue: 8 Oct. 2007

Buyer Model: 27 inch Washers (Except for WM1812CW, WM1814CW, WM1815CS)	
LGE Model: 27 inch Washers (Except for WD-90282BD, WD-90280BD, WD-90286BD)	
Buyer Name: * EUS, * ECI	Effective Date: 1 Oct.2007
Applicable Serial No: All Production Lots since 20 Sep. 2007 (709KWxxxxxxx)	
SUBJECT: New Door Gasket (Boot) Application for odor reduction	
PHENOMENON	See the guidelines below if service requires replacement of the Gasket or Outer Tub
<p>A drain hole has been added to the gasket (boot) of some lots produced since September, 2007. Gaskets (boots) with the drain hole do not appear in washers produced in August, 2007 or earlier.</p> <p>Install a gasket without drain hole on washers that were produced in August, 2007 or earlier. For washers produced since September, 2007, it is necessary to check and see if they were manufactured with a new gasket (with drain hole) or old gasket (without the drain hole).</p> <p>See the following pages for model and part number application information.</p> <p>NOTES:</p> <ol style="list-style-type: none"> Part numbers have been changed only on new gaskets. They have not been changed on outer tubs or balance weights. To Replace: <ol style="list-style-type: none"> Gasket only - Check manufacture date and, on newer models, inspect the existing gasket. See the following pages for the correct model and part number information. Tub Cover (Outer Tub) only - Replace old Tub Covers with new Tub Cover Assemblies but replace new Tub Covers with new Tub Covers (not assemblies). The existing inventory of old Tub Covers may be used as replacements for old Tub Covers only. Balance Weight - New weights can be used on all products. Old weights <u>cannot</u> be used on washers produced after August, 2007. Tub Cover Assembly - New Tub Cover Assemblies can be used on all washing machines. 	

*Interchangeability Code	Alphabetic Code		Numeral Code	
	A	Interchangeable : Old and new parts can be used in products as the bulletin regardless of manufacturing date.	1	To improve performance
	B	Old parts can be substituted for new : Old parts can be used in products regardless of manufacture date. New parts can be used in new products only.	2	To improve productivity
	C	New parts can be substituted for old parts : Only new parts can be used in products regardless of manufacture date.	3	To improve reliability
	D	Not interchangeable : New parts can be used in new products only.	4	Change of material or dimension
		5	Addition	
		6	Deletion	
		7	Correction	

Min-Su Kang
Research Engineer
Washing Machine Lab
LG Electronics DAC

Gasket and Replacement Part Numbers

Old Gasket (No hole in Gasket)	→	New Gasket (Hole in Gasket)
4986ER0001A	→	4986ER0001C
4986ER0001B	→	4986ER0001D
4986ER0002A	→	4986ER0002E
4986ER0002B	→	4986ER0002F
4986ER0002C	→	4986ER0002G
4986ER0002D	→	4986ER0002H
4986ER0004A	→	4986ER0004E
4986ER0004B	→	4986ER0004F
4986ER0004C	→	4986ER0004G
4986ER0004D	→	4986ER0004H
MDS33059401	→	MDS33059402

Models & Part Numbers affected by this Service Bulletin:

MODEL	Tub Cove Assembly Part Number	Tub Cover Part Number	Old Gasket P/No.
			New Gasket P/No.
WM3632HW	3551ER0003B	3550ER0004A	4986ER0002A
			4986ER0002E
WM2432HW	3551ER0003A	3550ER0004A	4986ER0001A
			4986ER0001C
WM2032HW	3551ER0003A	3550ER0004A	4986ER0001A
			4986ER0001C
WM2032HS	3551ER0003A	3550ER0004A	4986ER0001A
			4986ER0001C
WM0532HW	3551ER0003A	3550ER0004A	4986ER0001A
			4986ER0001C
WM1832CW	3551ER0003C	3550ER0004B	4986ER0001B
			4986ER0001D
WM2442HW	3551ER0003A	3550ER0004A	4986ER0001A
			4986ER0001C
WM0642HW	3551ER0003A	3550ER0004A	4986ER0001A
			4986ER0001C
WM2244HWM	3551ER0003A	3550ER0004A	4986ER0001A
			4986ER0001C
WM2040CW	3551ER0003C	3550ER0004B	4986ER0001B
			4986ER0001D
WM2042CW	3551ER0003C	3550ER0004B	4986ER0001B
			4986ER0001D
WM2044CW	3551ER0003C	3550ER0004B	4986ER0001B
			4986ER0001D
WM2487HWM	3551ER0026B	3550ER0004A	4986ER0004C
			4986ER0004G
WM2487HRM	3551ER0026B	3550ER0004A	4986ER0004C
			4986ER0004G
WM2688HWM	3551ER0026B	3550ER0004A	4986ER0004C
			4986ER0004G
WN2688HWM	3551ER0026B	3550ER0004A	4986ER0004C
			4986ER0004G
WM2688HNM	3551ER0026B	3550ER0004A	4986ER0004C
			4986ER0004G
WN2688HNM	3551ER0026B	3550ER0004A	4986ER0004C
			4986ER0004G
WM2688HCM	3551ER0026B	3550ER0004A	4986ER0004C
			4986ER0004G
WM0001HTMA (New Model)	3551ER0026G	3550ER0004F	X
			4986ER0004G



Models & Part Numbers affected by this Service Bulletin (cont.):

MODEL	Tub Cove Assembly Part Number	Tub Cover Part Number	Old Gasket P/No.
			New Gasket P/No.
WM2677HSM	3551ER0003G	3550ER0004A	4986ER0004A
			4986ER0004E
WM2677HBM	3551ER0003G	3550ER0004A	4986ER0004A
			4986ER0004E
WM2677HWM	3551ER0003G	3550ER0004A	4986ER0004A
			4986ER0004E
WM3677HW	3551ER0003B	3550ER0004A	4986ER0002A
			4986ER0002E
WM2277HW	3551ER0003R	3550ER0004A	4986ER0004B
			4986ER0004F
WM2277HB	3551ER0003R	3550ER0004A	4986ER0004B
			4986ER0004F
WM2277HS	3551ER0003R	3550ER0004A	4986ER0004B
			4986ER0004F
WM2177HW	3551ER0003M	3550ER0004A	4986ER0004B
			4986ER0004F
WM2077CW	3551ER0003H	3550ER0004B	4986ER0004B
			4986ER0004F
WM2075CW	3551ER0003H	3550ER0004B	4986ER0004B
			4986ER0004F
WM2377CW	3551ER0003Q	3550ER0004B	4986ER0004B
			4986ER0004F
WM2496HWM	3551ER0026C	3550ER0004A	4986ER0004A
			4986ER0004E
WM2496HSM	3551ER0026C	3550ER0004A	4986ER0004A
			4986ER0004E
CW2079CWD	3551ER0003Q	3550ER0004B	4986ER0004B
			4986ER0004F
CW2079CWN	3551ER0003Q	3550ER0004B	4986ER0004B
			4986ER0004F
WM2233HW	3551ER0003R	3550ER0004A	4986ER0004B
			4986ER0004F
WM2233HS	3551ER0003R	3550ER0004A	4986ER0004B
			4986ER0004F
WM2455HW	3551ER0003R	3550ER0004A	4986ER0004B
			4986ER0004F
WM2455HG	3551ER0003R	3550ER0004A	4986ER0004B
			4986ER0004F
WM2016CW	ACQ32362101	MCK33060001	MD S33059401
			MD S33059402





Comparison of Old and New Parts

	Old Part	New Part
Tub Cover		
Balance Weight		

Comparison of Old and New Parts

	Old Part	New Part
Gasket (Boot)		
Tub Cover Assembly		

Additional Parts

<p>Models</p>	<p>WM3632HW, WM2432HW WM2032H(*), WM0532HW WM1832CW, WM2442HW WM0642HW, WM2244HWM WM2040CW, WM2042CW WM2044CW, WM2487H(*)M WM2688H(*)M, WM2677H(*)M WM3677HW, WM2277H(*) WM2177HW, WM2077CW WM2075CW, WM2377CW WM2496H(*)M, CW2079CW(*) WM2233H(*), WM2455H(*) WM2455HG, WM0001HTMA</p>	<p>WM2016CW</p>
<p>Hose, Connector (Loc No: K570)</p>	<p>P/No: 5214FR4058Y</p>  <p>Curved to the right side</p>	<p>P/No: 5214FR4058Z</p>  <p>Curved to the left side</p>
<p>Connector, hose (Loc No: K571)</p>	<p>P/No: 4932ER4007B</p> 	
<p>Clamp (Loc No: K572)</p>	<p>P/No: 4861ER3068A</p> 	

PROCESS TECHNICAL INFORMATION

1. Standby
 - * The washer is plugged in but turned off.
2. Water Supply
 - * Drum rotates and fill begins after a cycle is selected.
 - * If PREWASH is selected, cold water is supplied via the PREWASH valve.
3. Soaking and Washing
 - * To facilitate wetting action, the load is tumbled clockwise and counterclockwise.
 - * If the water level is insufficient, the control board will continue to supply water until the correct level is reached.
4. Heating and Washing
 - * The heater heats the wash water in the tub and the drum rotates for washing.
 - * When the selected water temperature is reached, the heater is turned off but the drum continues to rotate.
 - * If the water temperature drops below the specification for that wash cycle, the heater will be energized again.
5. Washing
 - * FUZZY LOGIC determines the wash time according to load size, water temperature, and other factors.
6. Draining
 - * The drain pump drains the water from the sump.
 - * Spin starts after the pressure switch indicated the water has been drained.
 - * In cycles with hotter than usual water (Allergiene[®] and Sanitary cycles,) a cooling process is performed to lower the water temperature for safety and to avoid damaging the laundry.
7. Sensing Eccentricity
 - * The hall sensor is used by the microprocessor to determine eccentricity. It starts and stops the tumbling to redistribute the load.
 - * If the eccentricity is not resolved, the control board repeats the process. If the process is repeated several times without success, the machine stops and displays UE (Unbalance Error) on the control panel.
8. Intermittent Spin
 - * To set the correct spin speed, the motor spins the drum clockwise until it reaches the set spin speed.
 - * If the water level frequency is lower than 23.0 kHz, the control board interprets it as an oversudsing event and starts the desudsing process.

Process Technical Information, continued

9. Rinse Spin
 - * The water remaining in the load is extracted by centrifugal force while the drum is spun at the selected speed.
10. Remaining Spin
 - * The power to the motor is cut off and the drum continues to spin by inertia until it stops.
 - * This process overlaps the next process, rinsing.
11. Rinse Water Supply
 - * Cold water is supplied to the drum for rinsing the load.
12. Rinse
 - * After the water is supplied, the drum is rotated clockwise and counterclockwise to rinse the load.
13. Final Draining
 - * After the rinse cycle is completed, the power to the motor is cut off and the drum continues to spin by inertia until it stops.
 - * If RINSE HOLD is selected, the drum is not drained after the rinse cycle is completed.
14. Detangling
 - * At the end of the cycle, the power to the motor is cut off and the drum continues to spin by inertia until it stops turning. Then it is rotated slowly, alternately counterclockwise and clockwise, several times in each direction to help untangle the load.
15. End of Cycle
 - * At the end of the cycle, the display shows END for 8 seconds. The machine reverts to the STANDBY mode, and the door is unlocked.

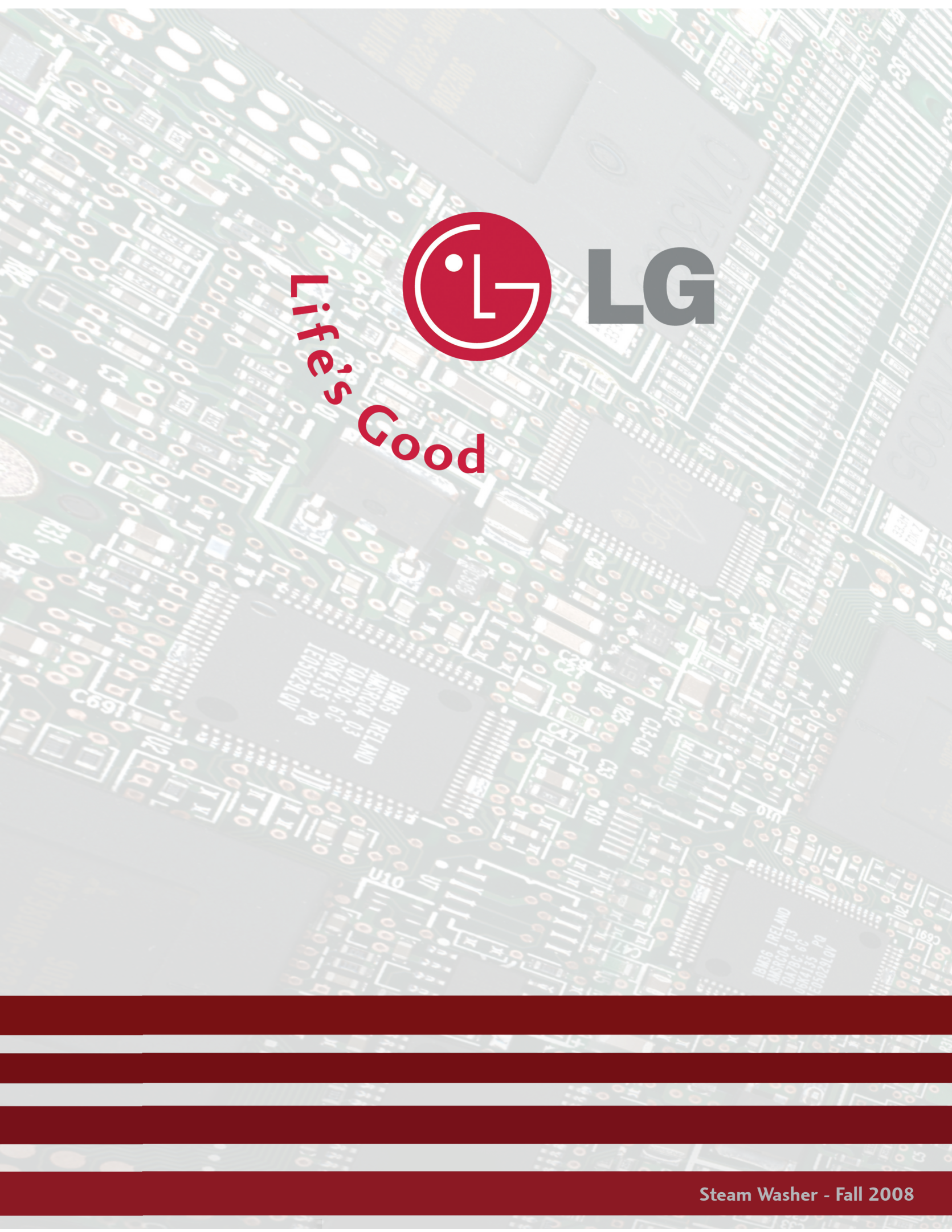

Life's
Good



LG