



☰ *Quick Fix*

Service Guide

Washers, Dryers, and Refrigerators

Quick Fix tips provide a ready reference to the most frequently occurring repairs and adjustments that service technicians are likely to encounter. This reference is not intended to replace the Owner's Manual or the Service Manual. Those manuals are available to servicers at <http://aic.lgservice.com>.

Servicer feedback and repair hints are welcome. Please submit your comments to:

LG Electronics, Alabama, Inc.
201 James Record Road
Huntsville, AL 35824
Attn: Education & Product Engineering

Or send an email to: QFsuggestions@lge.com

Contents

Refrigerators

1. Ice Makers
2. Water Connections
3. Door Adjustments
4. Plastic Drawers in Freezer
5. Ice in Freezer

Washers

1. Noise and Vibration
2. Water Leaks
 - 2.1. Around the Door
 - 2.2. Under the Washer
3. Door Gasket Odor

Dryers

1. Ventilation
2. Thermostat Service

Refrigerators

1. Ice Makers

There are two types of automatic ice makers used in LG refrigerators.

Twist Tray ice makers are mounted to the top of the freezer compartment. After removing one Phillips head screw, pull the assembly forward to remove it from the freezer compartment.

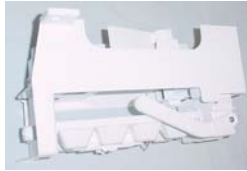

CustomCube™ ice makers are mounted to the side or the rear of the freezer compartment. Remove one Phillips head screw and lift the assembly off two shoulder screws to remove it from the freezer compartment.



2. Water Connections

LG refrigerators use molded plastic fittings to connect ice makers, dispensers, filters, and solenoids within the refrigerator. Never use a tool to try to disconnect a fitting. They can be easily removed by pressing the release ring toward the fitting and then pulling the tubing from the fitting. Use a plastic snap ring (available from LGEAI) under the *Quick disconnect* ring to prevent accidental release of any fitting that might be bumped or pulled.



Snap Ring (LG Part No. 4930JA3091A)

Please note that Quick disconnects are not used for supply water hookups on new refrigerators. LG now uses a standard flare fitting connector. See the Service Bulletin on this subject in the appendix.

3. Door Adjustments (French Door Models)

Slight adjustment of door height is possible by using the leveling feet to raise either the left or right side. Further adjustment, if needed, is made by inserting a snap ring over the lower hinge pin of the door that needs to be raised. This can be done easily by lifting the door with one hand while inserting a snap ring with a needle nosed pliers as shown below.

Note: A packet containing three snap rings is included with the Owner's Manual in each new refrigerator.

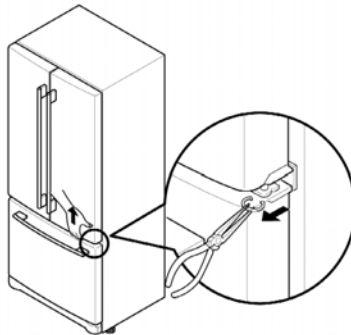

4. Plastic Drawers in Freezer

Some side-by-side models of LG refrigerators (LRSC269xxxx) have given evidence of problems in which plastic drawers in the Freezer compartment fall off the side rails. This problem has been addressed by the design engineers and modifications have been made to both the drawer design and the rollers in the side rails. Replacement drawers and side rails can be ordered from LGEAI.

5. Ice in Freezer Drawers

Some refrigerators (Models LRDxxxxxxx - drawer type bottom mounted freezer compartments) have had extreme frost accumulation because of the drawers not being tightly closed.

New side rail assemblies that have been redesigned to assure tight closing are available from LGEAI. Order Part Number 5218JJ2003B (2 required – the assembly fits both right and left sides).



Refrigerators

Washing Machines

1. Noise and Vibration

ALWAYS CHECK THAT SHIPPING BOLTS ARE REMOVED!

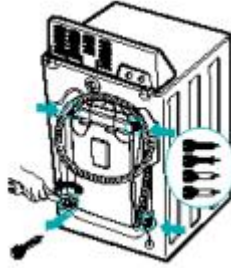

Important Note: Shipping Bolts should be removed AFTER the washer has been placed in the laundry room! They should NEVER be removed in the seller's shop or on the delivery truck. Internal components can be damaged when the washer is lifted in and out of a truck and when it is moved over curbs or stairs, even when strapped to an appliance dolly.

Always leave the shipping bolts with the customer. They will be needed if the washer is ever sold or moved.

Noise and Vibration problems in front load washers may be alleviated by readjusting the leveling feet.

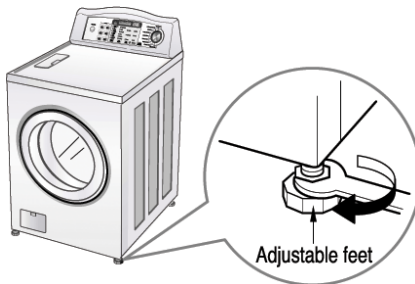

It is important that the washer is level. **It is even more important that the weight is as evenly distributed as possible on all 4 feet.**

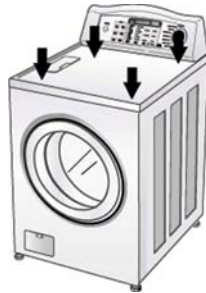

After leveling, press down on diagonal corners to be sure that there is no rocking. If the machine has lock washers on the leveling feet, turn them up firmly against the bottom of the machine so the feet will not vibrate loose.

If there is still noise and vibration after leveling, it may be necessary to replace the 3 dampers that support the tub. This can be done through the rear access panel. If the machine's installation location has enough room, the machine can be tipped forward about 45° (be sure that it is held firmly so that it cannot fall either forward or back). The two side dampers can then be easily reached from the bottom



Dampers as seen from the back.

2. Water Leaks

2.1. Around the Door

Check the Gasket Retaining Ring, making sure that it is present and properly seated around the gasket. Removing or replacing the ring requires the use of a

special Gasket Clamp Pliers, LG Part No. 383EER4001A.

Be sure that the hinge mounting screws are tight.

If the hinge screws are tight but the door does not close securely, the latch may be tightened by inserting flat washers between the door latch and the front panel,

2.2. Under the Washer

Water on the floor can be caused by any leak, anywhere in the washer.

2.2.1. Begin to troubleshoot by checking the water hoses supplying the washer.

2.2.2. Check the drain tube and the drain filter in the lower left corner.

Note: If the drain tube is leaking around the plug, it may be possible to stop the leak by cutting off about $\frac{1}{2}$ inch of the hose (to remove any stretched, hardened, or cracked part of the hose) and then reinserting the plug.

2.2.3. Remove the top of the washing machine (on WMxx32 washers, remove screws from the dispenser and tip the top up from the front so you can see inside without disconnecting the Control Board). It may also be necessary to remove the panel on the back of the washer.

2.2.4. Do a visual check of hoses, connectors, and components, looking for stains or other obvious sources of leaks.

2.2.5. Be sure that the drum is empty, then place the washing machine in QC Test Mode (Press and hold the **Spin Speed** and **Soil Level** buttons while turning the washer on with the **Power** button).

2.2.6. With the water faucets open and the washing machine in QC Test Mode, press the **Start/Pause** button to cycle through all of the washing machine functions. On each press of the **Start/Pause** button, the washing machine will advance to the next function. As it progressively uses hot and cold water, the circulation and drain pumps, and all of the water

control valves, the source of any leaks should become apparent so they can be repaired.

- 2.2.7. One source of leaks that can be hard to detect is a cracked or broken air chamber. This plastic chamber is located behind the drum, near the bottom (See below.)

Note that the nipple has been broken from the air chamber and is still in the connecting hose.

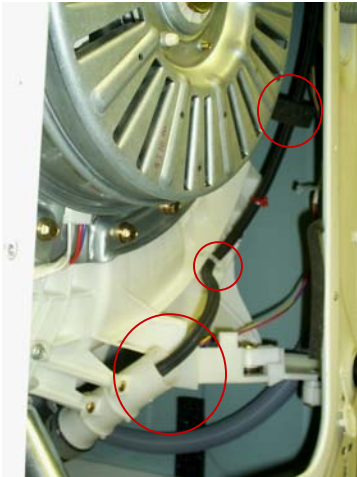
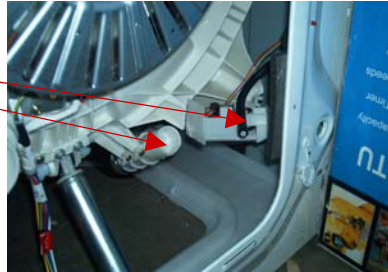

Repair Procedure







1. Replace the broken Air Chamber.
2. Disconnect the red zip tie from the cabinet back.
3. Slide the foam damper up the tube
4. Drill a 3/16" diameter hole and use a zip tie to attach the tube to the outer tub

The following table, which shows the steps of the QC test mode, is applicable to all Columbus, Mayflower, and Hudson washers. Not all models have all features, however (e.g. some models do not have water heaters). The washer you are servicing may have only 11 or 12 steps.

Number of times the Start/Pause button is pressed	Check Point	Display Status
None	Turns on all lamps and locks the door.	19:59 ¹⁾
1 time	Tumble clockwise.	rpm (40-50)
2 times	Low speed Spin.	rpm
3 times	High speed Spin.	rpm
4 times	Inlet valve for prewash turns on.	Water level frequency (60-255)
5 times	Inlet valve for main wash turns on.	Water level frequency (60-255)
6 times	Inlet valve for hot water turns on.	Water level frequency (60-255)
7 times	Inlet valve for softener turns on.	Water level frequency (60-255)
8 times	Inlet valve for bleach turns on.	Water level frequency (60-255)
9 times	Tumble counterclockwise.	rpm (40-50)
10 times	Heater turns on for 3 sec.	Water temperature
11 times	Circulation pump turns on.	Water level frequency (60-255)
12 times	Drain pump turns on.	Water level frequency (60-255)
13 times	Power off and unlock the door.	Turn off all lamps.

The following table is an explanation of the error codes which may appear in the washing machine's display panel

	ERROR	SYMPTOM	CAUSE
1	WATER INLET ERROR	1E	<ul style="list-style-type: none"> • Correct water level (2 level) is not reached within 8 minutes after water is supplied or it does not reach the preset water level within 25 minutes.
2	UNBALANCE ERROR	UE	<ul style="list-style-type: none"> • The load is too small. • The appliance is tilted. • Laundry is gathered to one side. • Non distributable things are put into the drum.
3	DRAIN ERROR	DE	<ul style="list-style-type: none"> • Not fully drained within 10 minutes.
4	OVER FLOW ERROR	FE	<ul style="list-style-type: none"> • Water is overflowing (over 8 level). • If FE is displayed, the drain pump will operate to the drain water automatically.
5	PRESSURE SENSOR ERROR	PE	<ul style="list-style-type: none"> • The SENSOR SWITCH ASSEMBLY is out of order.
6	DOOR OPEN ERROR	OE	<ul style="list-style-type: none"> • Door not all the way closed. • Loose electrical connections at Door switch and PWB Assembly. • The DOOR SWITCH ASSEMBLY is out of order.

7	HEATING ERROR		<ul style="list-style-type: none"> The THERMISTOR is out of order.
8	OVER CURRENT ERROR		<ul style="list-style-type: none"> MAIN PWB ASSEMBLY is out of order. Winding in the STATOR ASSEMBLY is short-circuited.
9	LOCKED MOTOR ERROR		<ul style="list-style-type: none"> The connector (3-pin, male, white) in the MOTOR HARNESS is not connected to the connector (3-pin, female, white) of STATOR ASSEMBLY. The electric contact between the connectors (3-pin, male, white) in the MOTOR HARNESS and 4-pin, female, white connector in the MAIN PWB ASSEMBLY is bad or unstable. The MOTOR HARNESS between the STATOR ASSEMBLY and MAIN PWB ASSEMBLY is cut (open circuited). The hall sensor is out of order/defective.
10	BALL SENSOR ERROR		<ul style="list-style-type: none"> Loose Ball Sensor Connector. Ball Sensor is out of order. <ul style="list-style-type: none"> Displayed only when the START / PAUSE button is first pressed in the QC Test Mode.
11	EEPROM ERROR		<ul style="list-style-type: none"> EEPROM is out of order. <ul style="list-style-type: none"> Displayed only when the START / PAUSE button is first pressed in the QC Test Mode.
12	POWER FAILURE		<ul style="list-style-type: none"> The washer experienced a power failure.

3. Door Gasket Odor

Drum washing machines have a large rubber gasket around the door. It is inevitable that some moisture will be left within the folds of the gasket at the end of the wash cycle. This water is quite clean (because the rinse cycle gets rid of soapy water before the spin cycle begins) but over a period of time some soap residue can accumulate. Since this is a condition that customers are not used to if they have used top loading machines, LG has provided warranty coverage for replacing the door gasket in some extreme cases.

The problem is compounded because, with a large drum washer, customers don't use the washer often enough to keep the water rinsed out.

The problem can be alleviated by teaching customers to simply wipe the folds of the door gasket with a towel when they remove the clothes from the last load of the day.

Clothes Dryers

1. Ventilation

Improper or obstructed exhaust venting may account for more than 75% of clothes dryer service calls, according to some estimates. Improper installation and user failure to regularly clean the exhaust ducts is not included in the manufacturer's warranty coverage.

Symptoms or complaints may include:

- Clothes not drying
- Takes too long for clothes to dry.
- Dryer not getting hot enough

Check – The above symptoms may also indicate a component failure. An easy way to check is to visually check the filter, disconnect the dryer from the exhaust vent, and run the dryer with the vent disconnected. If there was a venting problem, the dryer will quickly reach high temperature and a high volume of hot air will be felt at the dryer's exhaust.

2. Thermostat Service

A Service Bulletin (WW/M20040036) has been issued which applies to Electric Dryers of the Columbus and Mayflower model lines (DLExx32x & DLExx77x models). When you check or service a thermostat, check the wiring connections to be certain that they are as shown in the following pictures.



Heater



Change
from this



to this