

TRAINING MANUAL

WM2496 Washer Training
Spring 2007



LG Service

Digital Appliance

WM2496H*M

Contact Information	cover
Safety Notices and Warnings	1
Contents	2
Introduction	4
Specifications	5
Features	6
Display and Controls	7
Warranty	8
Serial Number Identification	9
Fuzzy Logic	10
Door Lock	10
Door Locked Lamp	10
Water Circulation	11
Parts Identification (Callout)	12
Accessories	13
Remote Monitor and Modem	14
Installation	15
Pedestal	16
Connections	18
Water	18
Drain	18
Electrical	18
Program Chart	19
Before Performing Service	19
Dispenser	20
Test Mode	22
Check Water Level Frequency	22
Error Display (Error Codes)	23
Diagnosis and Check Lists	25
Door Error	25
Drain Error	25
Oversudsing	26
Laundry products Do Not Dispense	26
Other Errors	26

Diagnosis and Troubleshooting	27
No Power	27
Noise and Vibration During Spin	28
SpinSense (to resolve vibration issues)	29
No Water Supply	30
Detergent Does Not Flow In	30
Bleach and Softener Do Not Flow In	31
Heater Operation Without Water	32
Abnormal Sound	32
Drain Malfunction	32
Wash Heater Malfunction (No Heating)	33
Heater Malfunction (Continuous Overheating)	33
No Water Circulation	34
Spin Malfunction	35
dE Error Code	35
Disassembly and Repair	36
Block Wiring Diagram	36
Top Plate	36
Control Panel	37
Main Board	38
Dispenser	39
Noise Filter	39
Front Cabinet Cover	40
Door	42
Door Switch Removal	42
Pumps (Drain and Circulation)	43
Heater	44
Thermistor	44
Removal of Objects Between Tub and Drum	45
Motor	46
Tub and Drum	48
Damper	49
Tips and Tricks	50
Hoses	50
Baffles (Roller Jets)	50
Mushroom Valve	50
Ball Sensor (Off Balance Sensor)	50
Wiring Diagram	51
Exploded Views	52
Parts List	55

070125

INTRODUCTION

The WM2496 washer and dryer are very similar to the previous series, with the exception of the re-shaped front panel and the convertible dryer control. The WM2496 machines are specifically designed to be sold as a stacked product, and the dryer is delivered with the control panel mounted at the bottom of the dryer. This causes the washer and dryer control panels to be adjacent when the products are installed and stacked. Of course, they can be installed in a standard, side-by-side configuration with the dryer controls mounted at the top of the dryer.

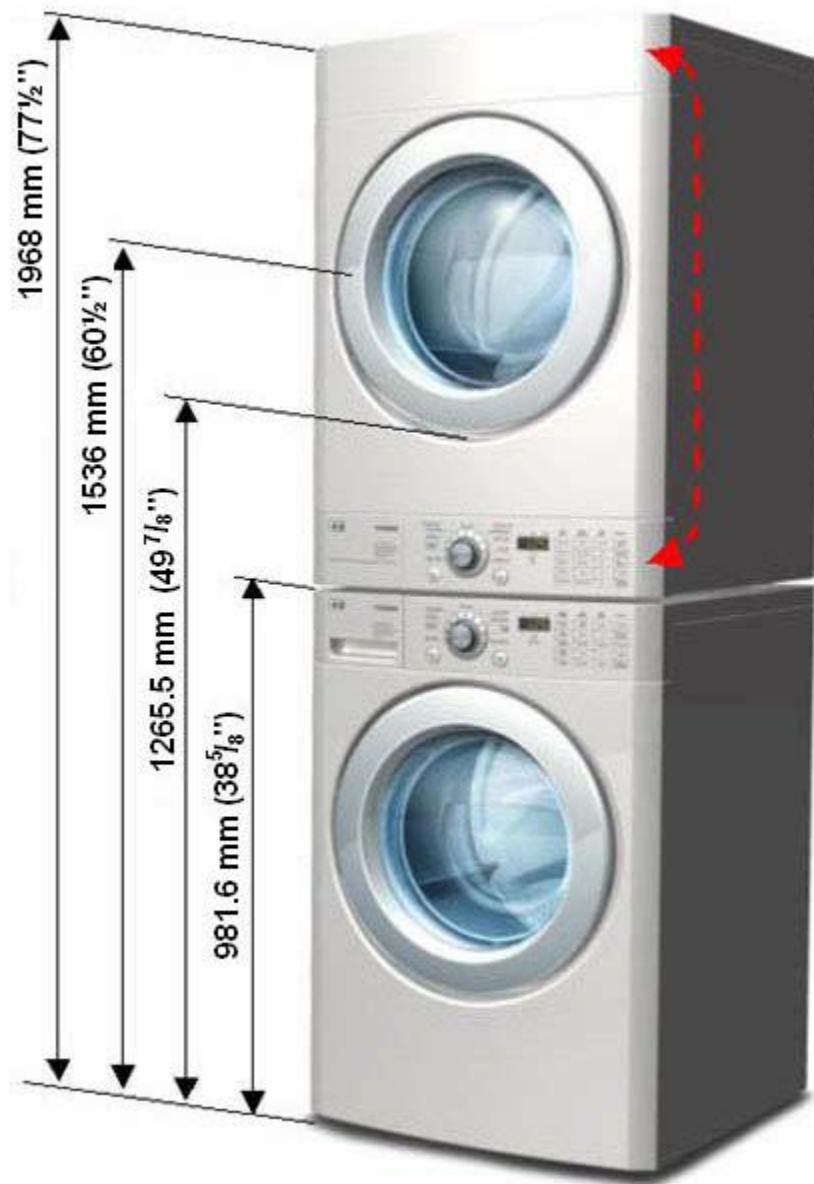

SPECIFICATIONS

ITEM	WM2496H*M	
COLOR	W:BLUE WHITE, S: TITANIUM	
POWER SUPPLY	AC 120 V, 60 Hz	
PRODUCT WEIGHT	192 lbs (87kg)	
ELECTRIC POWER CONSUMPTION	WASHING	280 W
	DRAIN MOTOR	80 W
	WASH HEATER	1000 W
REVOLUTION SPEED	WASH	46 rpm
	SPIN	0-1,150 rpm
CYCLES	9	
WASH/RINSE TEMPERATURES	5	
SPIN SPEEDS	5	
OPTIONS	Prewash, Rinse+Spin, Extra Rinse, Water Plus, Stain Cycle	
WATER CIRCULATION	Incorporated	
OPERATIONAL WATER PRESSURE	14.5–116 psi (100-800 kPa)	
CONTROL TYPE	Electronic	
WASH CAPACITY [cu.ft.]	3.47 (4.0 IEC)	
DIMENSIONS	27" (W) X 29 ³ / ₄ " (D) X 38 ¹¹ / ₁₆ " (H), 50 ¹³ / ₁₆ " (D, door open)	
DELAY WASH	up to 19 hours	
DOOR SWITCH TYPE	PTC + Solenoid	
WATER LEVEL	10 steps (by sensor)	
LAUNDRY LOAD SENSING	Incorporated	
ERROR DIAGNOSIS	Incorporated	
AUTO POWER OFF	Incorporated	
CHILD LOCK	Incorporated	
RLM ENABLE	Incorporated	

FEATURES

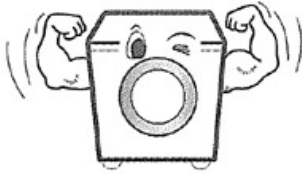

LARGE CAPACITY

The larger drum (4.0 cu. ft.) allows washing of larger (heavier) loads and oversized items (comforters, curtains, blankets, etc.) There is less wrinkling and tangling of the laundry.



DIRECT DRIVE

The brushless DC motor drives the drum directly without belts, pulleys, or transmissions. The maximum spin speed of 1,150 RPM extracts more water from the laundry, reducing drying times.

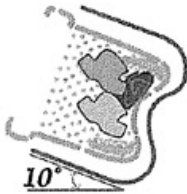

TILTED DRUM/LARGE DOOR

The tilted drum (10°) and large door opening allow easier loading and unloading.

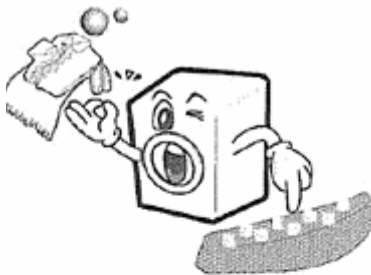

ROLLER JETS and BALLS

The baffles pick up water as the drum turns and allow it to pour through the clothing as it tumbles. The balls enhance the washing performance while maintaining fabric care.

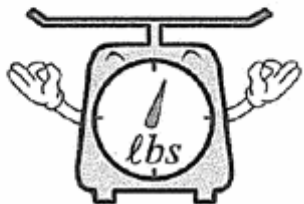

AUTOMATIC LOAD DETECTION

The microprocessor reads the current required to turn the drum and determines the weight of the load. This input is used to make numerous decisions during the wash cycle.

FEATURES, continued

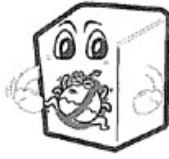

BUILT-IN HEATER

The internal heater helps maintain the water temperature at its optimal temperature for selected cycles. The SANITARY cycle kills most common germs and bacteria.



CHILD LOCK

This allows the user to lock the controls. Children then cannot play with the buttons and disturb the wash cycle.



REMOTE LAUNDRY MONITOR

Available separately, the remote monitor displays the cycle and remaining time on the washer and dryer. It can be plugged in to any outlet in the house.

DISPLAY and CONTROLS



The control panel is located on the front of the WM2496 Washer. All options are available from the control panel.

Extra Hot	167° F	Extra High	1,150	SOIL LEVEL	STAIN CYCLE
Hot	122° F	High	980	adds time to	adds time and
Warm	104° F	Normal	960	wash and	changes
Cold	77° F	Low	600	spin cycles	temperature

Press **EXTRA HOT/COLD** and **EXTRA HIGH** to read the drum RPM.

Press **WARM/WARM** and **NORMAL** to read the water temperature in ° Celsius.

Press **WARM/COLD** and **LOW** to read the water level frequency.

WARRANTY

LG ELECTRONICS, INC. LG Washing Machine Limited Warranty - USA



Your LG Washing Machine will be repaired or replaced, at LG's option, if it proves to be defective in material or workmanship under normal use, during the warranty period ("Warranty Period") set forth below, effective from the date ("Date of Purchase") of original consumer purchase of the product. This warranty is good only to the original purchaser of the product and effective only when used in the United States, including Alaska, Hawaii, and U.S. Territories.

<u>WARRANTY PERIOD:</u>	<u>HOW SERVICE IS HANDLED:</u>
<p>LABOR: One Year from the Date of Purchase.</p> <p>PARTS (except as listed below): One Year from the Date of Purchase.</p> <p>Electronic Control Board: 2 Years from the Date of Purchase.</p> <p>Drum Motor: 7 Years from the Date of Purchase.</p> <p>Stainless Steel Drum: Lifetime</p> <p>Replacement Units and Repair Parts may be new or factory remanufactured.</p> <p>Replacement Units and Repair Parts are warranted for the remaining portion of the original unit's warranty period.</p>	<p>In-Home Service: Please retain dealer's dated bill of sale or delivery ticket as evidence of the Date of Purchase for proof of warranty, and submit a copy of the bill of sale to the service person at the time warranty service is provided.</p> <p>Please call 1-800-243-0000 and choose the appropriate option to locate your nearest LG Authorized Service Center.</p> <p>Or visit our website at: http://www.lgservice.com</p>

THIS WARRANTY IS IN LIEU OF ANY OTHER WARRANTY, EXPRESS OR IMPLIED, INCLUDING WITHOUT LIMITATION, ANY WARRANTY OF MERCHANTABILITY OR FITNESS FOR A PARTICULAR PURPOSE. TO THE EXTENT ANY IMPLIED WARRANTY IS REQUIRED BY LAW, IT IS LIMITED IN DURATION TO THE EXPRESS WARRANTY PERIOD ABOVE. NEITHER THE MANUFACTURER NOR ITS U.S. DISTRIBUTOR SHALL BE LIABLE FOR ANY INCIDENTAL, CONSEQUENTIAL, INDIRECT, SPECIAL, OR PUNITIVE DAMAGES OF ANY NATURE, INCLUDING WITHOUT LIMITATION, LOST REVENUES OR PROFITS, OR ANY OTHER DAMAGE WHETHER BASED IN CONTRACT, TORT, OR OTHERWISE. Some states do not allow the exclusion or limitation of incidental or consequential damages or limitations on how long an implied warranty lasts, so the above exclusion or limitation may not apply to you. This warranty gives you specific legal rights and you may also have other rights that vary from state to state.

THIS LIMITED WARRANTY DOES NOT APPLY TO:

- Service trips to your home to deliver, pick up, and/or install the product, instruct, or replace house fuses or correct wiring, or correction of unauthorized repairs.
- Damages or operating problems that result from misuse, abuse, operation outside environmental specifications or contrary to the requirements of precautions in the Operating Guide, accident, vermin, fire, flood, improper installation, acts of God, unauthorized modification or alteration, incorrect electrical current or voltage, or commercial use, or use for other than intended purpose.

The cost of repair or replacement under these excluded circumstances shall be borne by the consumer.

CUSTOMER INTERACTIVE CENTER NUMBERS

<p>To obtain Customer Assistance, Product Information, or Dealer or Authorized Service Center location:</p>	<p>Call 1-800-243-0000 (24 hours a day, 365 days per year) and select the appropriate option from the menu. Or visit our website at: http://www.lgservice.com</p>
---	---

TO CONTACT LG ELECTRONICS BY MAIL:

LG Customer Interactive Center
P. O. Box 240007
201 James Record Road
Huntsville, Alabama 35813
ATTN: CIC

SERIAL NUMBER IDENTIFICATION

The serial number is unique to each product. It gives information concerning the time and place of manufacture. The serial number is required to be paid for warranty service and to get the correct part in the event a running production change was made. Some models may have four (4) letters instead of two (2) for the product code number. The third and fourth letters are significant only to the manufacturing facility.

This chart will help you decode the serial number.

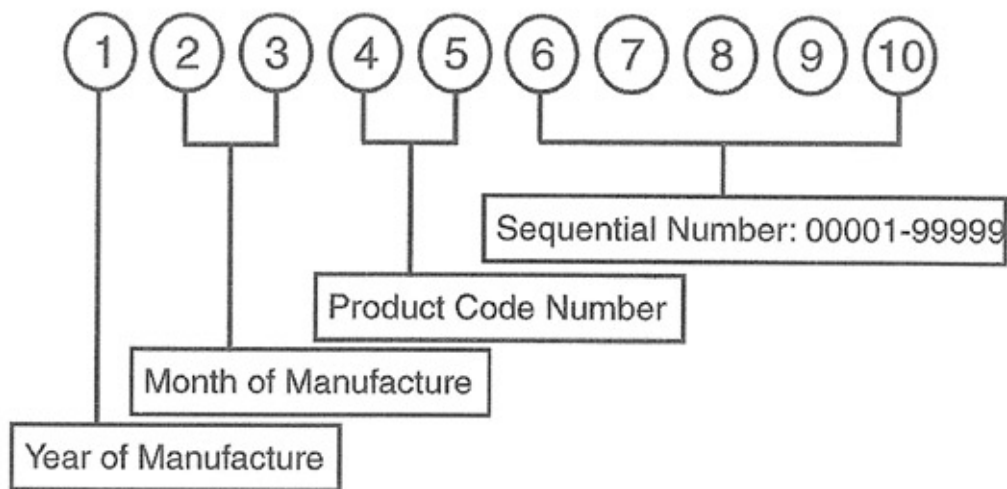

Example

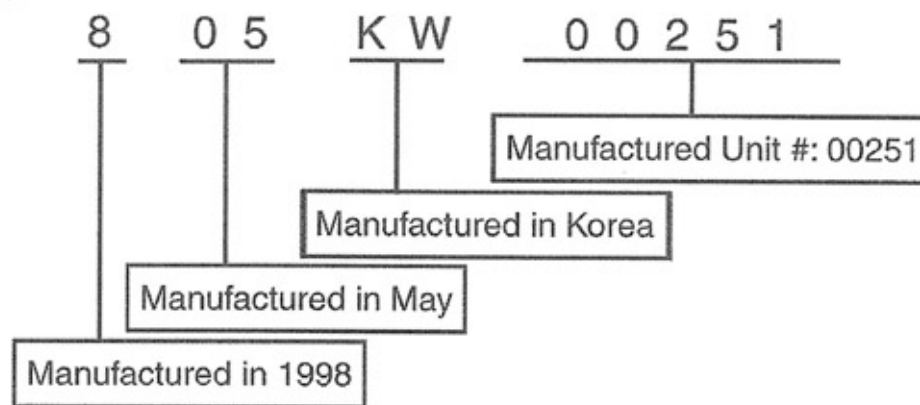

FUZZY LOGIC

To get the best washing performance, the user selects one of the standard cycles and sensors in the **WM2496** make an infinitely variable number of adjustments as the cycle progresses. Adjustments are automatically made for load size, incoming water temperature, soil level, rinses required, and other variables.

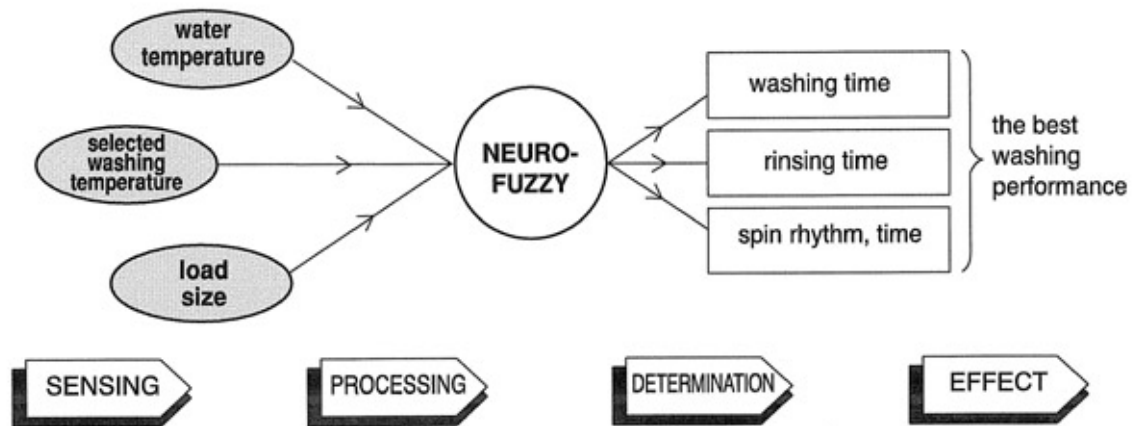

DOOR LOCK

The door has an automatic, electrically operated lock system. When the machine is off or paused, the door can be opened by pulling it. When the machine is operating, the electric latch keeps the door closed.

The door cannot be opened:

- When the WM2496 is operating
- When the power failed or the washer is unplugged (until the capacitor discharges and releases the lock)
- When the DOOR LOCK light is on
- When the drum is still turning

DOOR LOCKED LAMP

The DOOR LOCK lamp lights:

- When the WM2496 is operating
- When the water level sensor frequency is lower than 22.9 kHz
- When the temperature inside the tub is over 45° C (113°F)

WATER CIRCULATION

The recirculation pump circulates the water during most of the cycle. During the WASH cycle, it runs continuously for the first 3 minutes and then intermittently throughout the cycle. During the RINSE cycle, it runs continuously as soon as the appropriate amount of rinse water has been added. This recirculated water enters the drum at the top of the door at a small shower head. This spray not only keeps the window and gasket clean, it allows the clothes to be soaked with detergent or rinse water more quickly and can be used to control an oversudsing event.

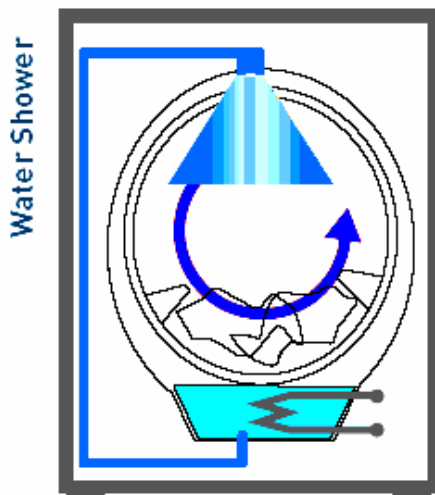

The recirculation pump is separate from the drain pump, but they are attached to opposite sides of the filter housing.

When the sanitary cycle is used, the door will remain locked until the laundry has cooled to a safe temperature (below 45° C / 113°F).

The pumps and filter are located at the bottom left front corner. The filter can be unscrewed, cleaned, and replaced by opening the small cover.



Use the small drain hose to evacuate the water remaining in the bottom of the tub before removing the filter. Do not pull it out so far the hose is kinked or water will not flow.

The drain pump is on the left and exhausts the water via the gray corrugated hose.

The recirculating pump is on the right and recirculates water from the tub to the shower spray at the top of the door gasket via the smaller black hose.

PARTS IDENTIFICATION

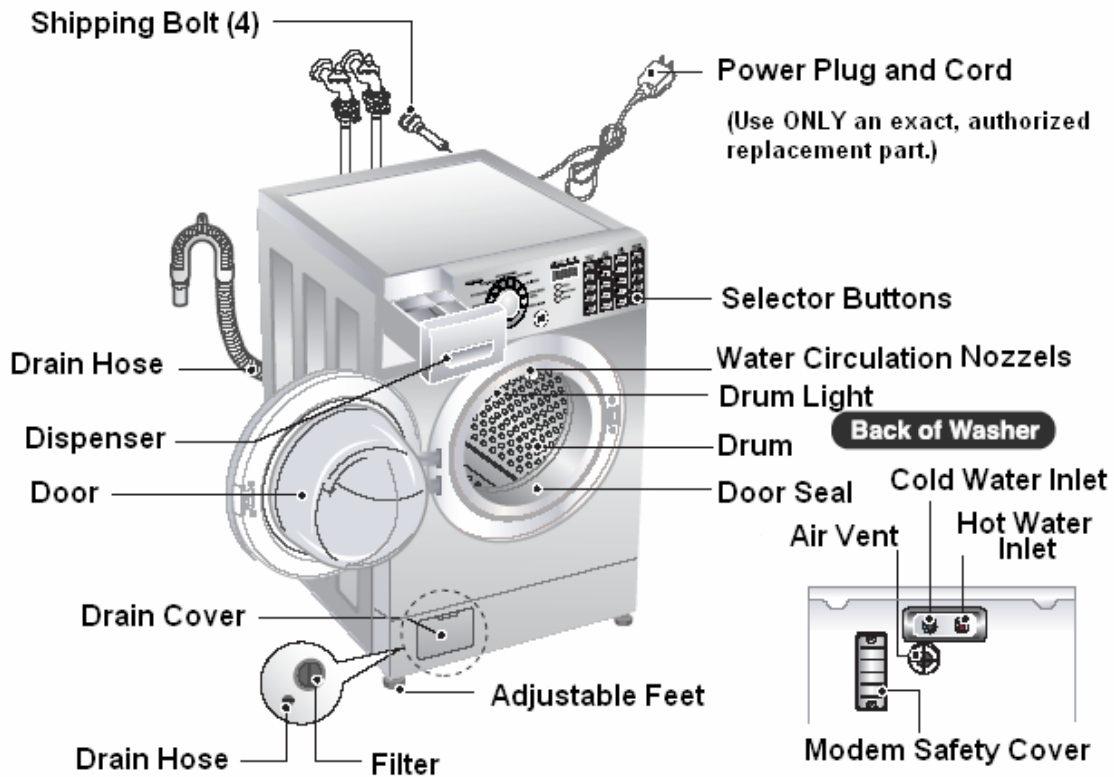

The air vent on the back of the machine must be left open and clear at all times.

If the washer is installed in a closet or closed laundry alcove, there must be sufficient clearance and ventilation. The closet should have a full louvered door with at least 350 square inches (0.5 m²) of open area for ventilation.

The washer requires a space of at least 1 inch (2.5 cm) between the wall and the machine on each side and at least 4 inches (10 cm) between the back of the washer and the wall. Additional space may be needed for servicing.

ACCESSORIES

The washer comes with the two input hoses. The blue stripe is for cold water and the red stripe is for hot water. While the hoses appear to be mechanically identical, the temperature and pressure ratings are different. It is critical to the performance of the washer to have the hot and cold hoses connected correctly.

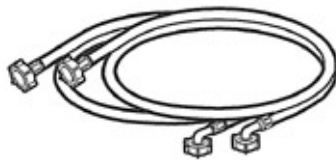

Hot/Cold (1 each)
Hose



Wrench



Tie strap (Option)
to secure drain hose to standpipe,
inlet hose, or laundry tub

The wrench is used to remove (and replace) the shipping bolts and to adjust the leveling feet. Be sure to leave it and encourage the customer to retain the wrench, the four shipping bolts, and the manual in a safe place in the event the washer requires service or the customer moves.

The **shipping bolts MUST BE REMOVED** before operating the washer. (See page 15.) Also check for the **packing block**, which sometimes remains in the base when the washer is unpacked.

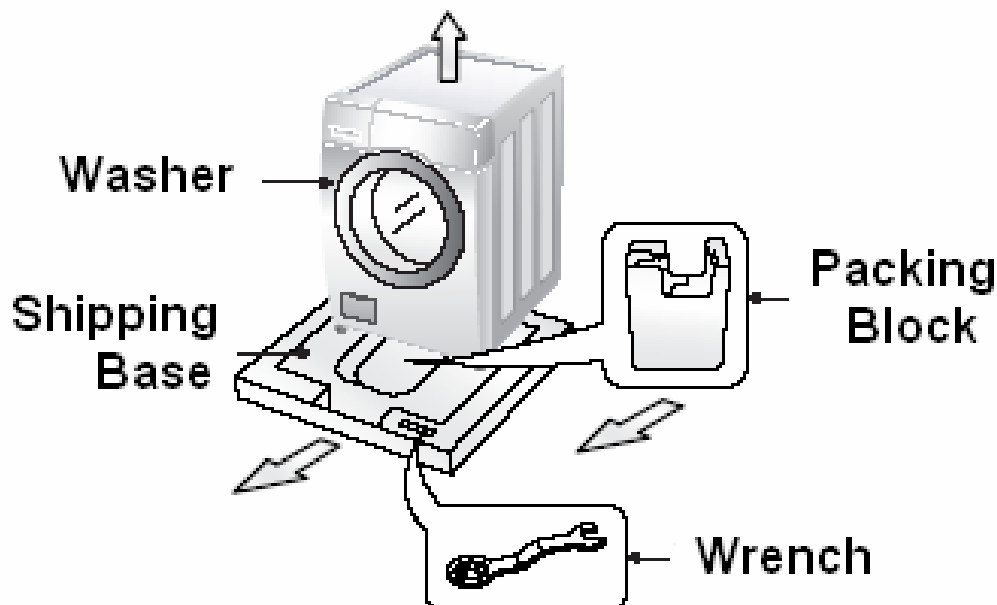

REMOTE MONITOR and MODEM



The remote laundry monitor (RLM) allows the user to monitor the progress of both washer and dryer, provided they are both equipped with a modem.



Remove the cover and install the modem on the back of the washer.

Save the small socket cover and screws in the event you need to remove the modem for some reason. The socket should be covered at all times.

While you're at it, go ahead and install the modem on the dryer now.



Remove the cover and install the modem on the back of the dryer.

Save the small socket cover and screws in the event you need to remove the modem for some reason. The socket should be covered at all times.

After installation is complete, plug in the washer, dryer, and monitor, in that order. Turn on the washer and dryer. Press and hold the SET button on the monitor.

INSTALLATION

REMOVE THE SHIPPING BOLTS.

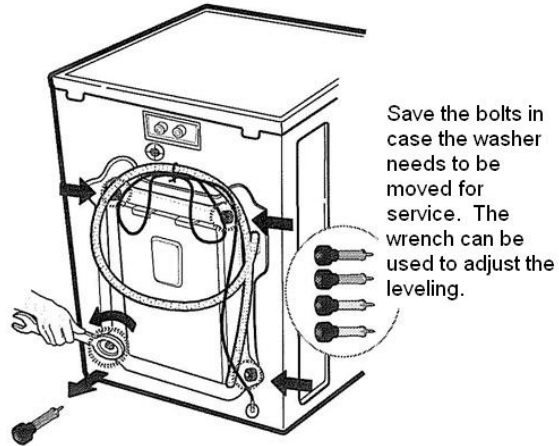

INSTALL THE WASHER ON A FIRM, FLAT SURFACE.

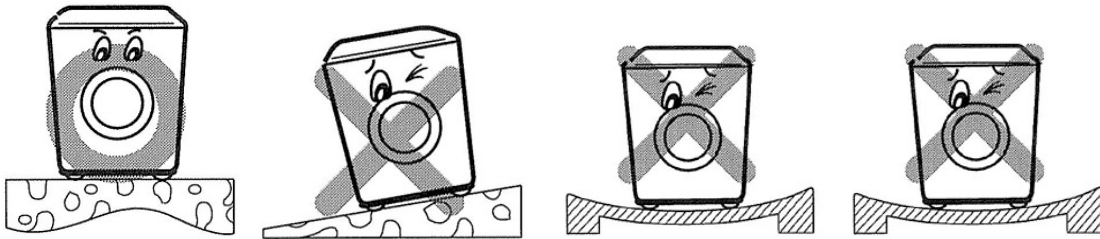

ADJUST THE FEET TO BE LEVEL.

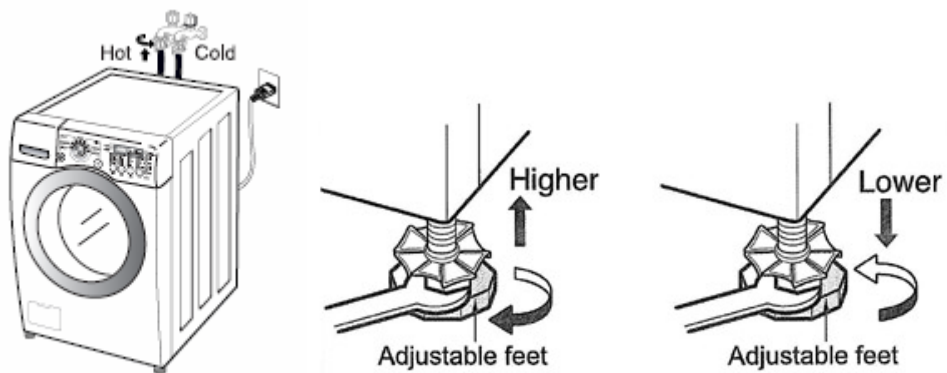

If you're installing the washer on a pedestal, install the pedestal now.
(See next page.)

INSTALLATION (PEDESTAL KIT)

This procedure covers installing and leveling the 7½” and 13” pedestals for 27” washers, dryers, and combos. If the products are stacked, the washer must be below the dryer, and you’ll use only one pedestal.

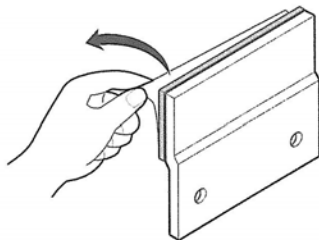
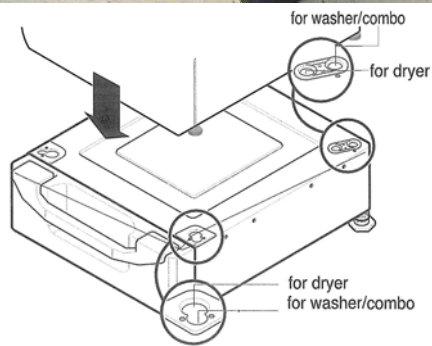
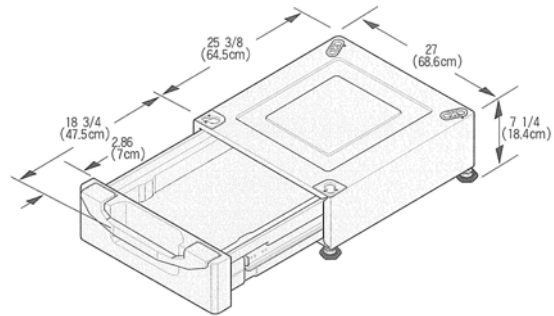

1. Remove the pedestal, installation hardware, and instructions from the shipping carton. Set the pedestal as close to the installation position as possible.
2. Level the pedestal on a flat, solid floor before proceeding. Lock down the rear adjusters but leave the front ones free for now.
3. Note which holes are for the washer and which are for the dryer. If you are stacking the appliances, the washer **must** be on the bottom.
4. Remove the protective paper from the adhesive surface of the bracket. Be particularly careful, because when the adhesive makes contact, there is no adjustment possible.

PEDESTAL, continued

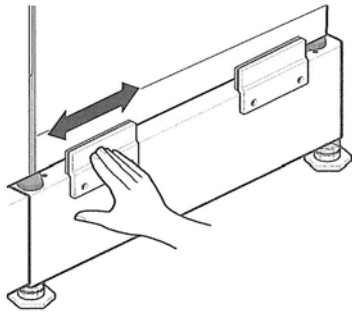
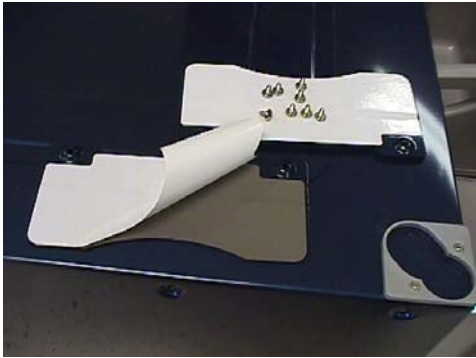

5. Depending upon the model, your pedestal may have straight or curved brackets. The curved ones are to be used on the rear positions when mounting a dryer to a pedestal, but can also be used in any other position on the pedestal.
6. Holding the exposed adhesive away from the appliance, insert the screws and get them started. Then press the brackets to the appliance and tighten all the screws. Rub the bracket from side to side to ensure a complete bond.
7. Use the wrench to turn each leg of the appliance approximately $\frac{1}{4}$ turn to put a little pressure between the appliance and the pedestal. This will eliminate any rattles.
8. It is usually easier to set the pedestal and washer into place and connect the water and drain hoses before placing the dryer on top of them.

CONNECTIONS

WATER

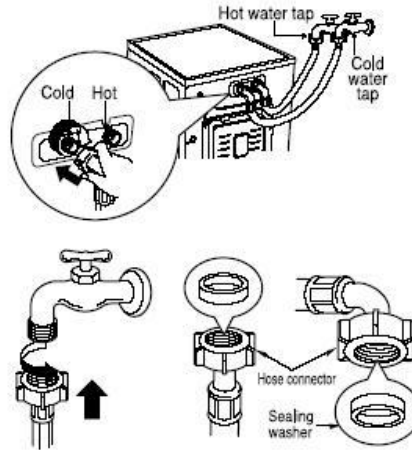

Be sure the rubber washer is inside the hose end. Attach the hoses to the washer (red is HOT, blue is COLD). Tighten them firmly but don't strip the plastic threads on the washer connections. The hoses may appear to be mechanically identical, but the hot hose is rated at a higher temperature and burst strength.

DRAIN

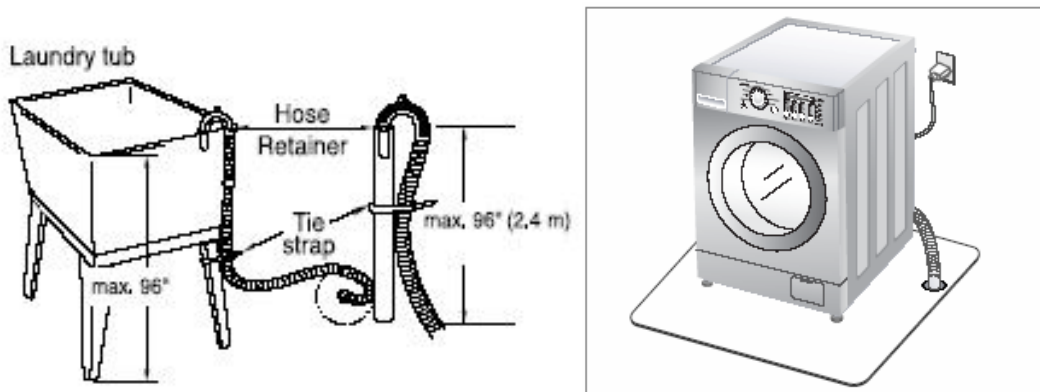

The drain pipe should be firmly attached to the standpipe or the laundry tub or sink where it drains. The pump has sufficient power to cause the pipe to move around when the water is expelled. The pump can lift the drain water a maximum of 96 inches (2.4 m), but there is no minimum height requirement. The vacuum breaker in the drain line will prevent drainage by gravity or siphoning. The hose can lay flat into a floor drain as long as the end of it is not submerged.

ELECTRICAL

The WM2496 washer requires a 120 VAC, 60 Hz., dedicated, 20-amp circuit.

PROGRAM CHART

PROGRAM CHART

* Water Supply: W-S * Intermittent Spin: I-S * Disentangle: D-T

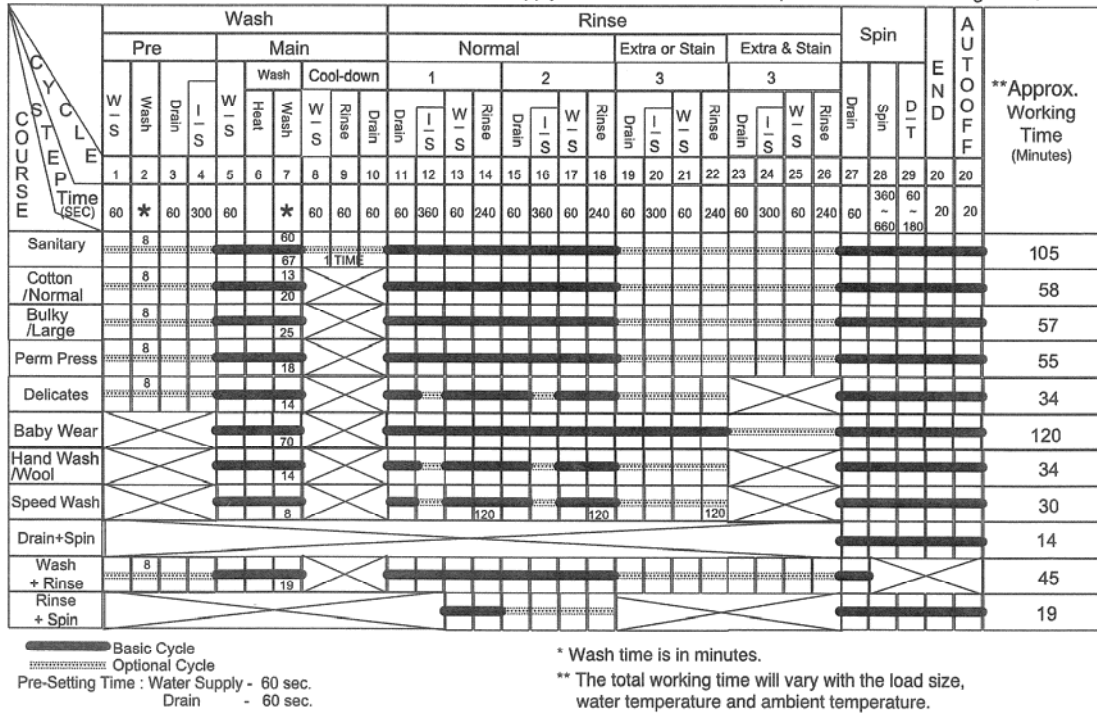

This chart shows the components and their times of operation in the various wash cycles. The time estimates shown here are for the basic cycles before the fuzzy logic adjustments are made.

BEFORE PERFORMING SERVICE

- Be careful to avoid electric shock when disconnecting parts for troubleshooting.
- Most terminals in the WM2496 washer have 120 VAC or DC on them, sometimes even when the washer is off.
- The built-in water heater operates at a high temperature.

DISPENSER

The dispenser drawer is a multi-chambered reservoir that allows the user to add all the appropriate laundry additives before starting the cycle. It has a place for pre-wash detergent, main wash detergent, fabric softener, and bleach. Powdered or liquid detergents may be use, but softener and bleach must be liquids. Detergents should carry the **HE** designation. Do not use regular detergents in the washer or oversudsing will occur. Regular detergents also cause a scum build-up in the tub, which leads to poor performance and a foul odor. If this build-up cannot be removed by running a TUB CLEAN cycle, the washer requires a complete disassembly to clean it.

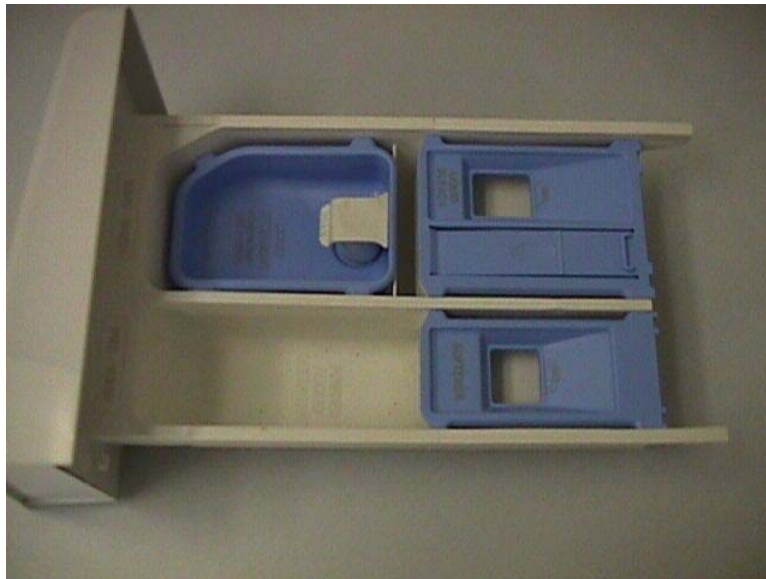

The top of the dispenser box is shown here.

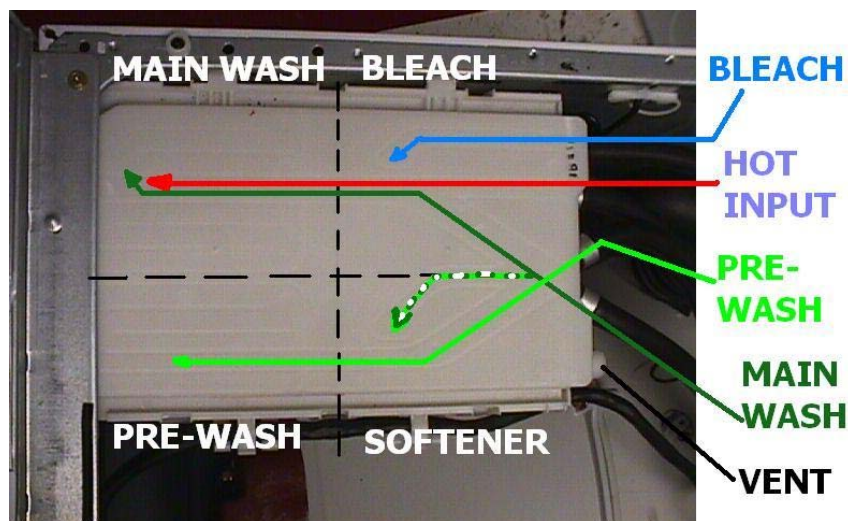

The dispenser works by using various solenoids to apply water to different compartments. The liquid products are dispensed from a siphon box. As the appropriate chamber is flooded, the box fills and the water flushes the laundry product into the tub. It is mixed with water before contacting the laundry to prevent spotting or damaging the fabric.

Notice that the pre-wash and main wash fill tubes enter the dispenser at an angle. If one or the other fill valve is opened, the water goes into the appropriate detergent compartment. However, if they are opened simultaneously, the streams deflect and dispense the softener. Some water may run through the main and pre-wash compartments, but since the detergent has already been dispensed in an earlier part of the cycle, this is of no consequence.

If liquid detergent is added to the pre-wash box, it will run immediately into the tub. This does not affect the operation of the cycle. To use liquid detergent in the main wash, place the detergent siphon box in the main wash compartment. Otherwise, the main wash liquid detergent will run into the tub along with the pre-wash detergent, causing oversudsing in the pre-wash and no cleaning in the main wash.

The siphon boxes are designed to hold a liquid laundry product until the appropriate time for dispensing into the load. When the box fills with water, it begins to discharge its contents into the washer fill stream. Once the siphon action has started, it will continue until the siphon box has emptied itself. Use only regular viscosity bleaches and softeners; the ultra versions are usually much thicker and do not dispense well, if at all.



By the end of any cycle, water will have run through all of the dispenser compartments, preventing any cross-contamination of subsequent loads.

TEST MODE

The WM2496 washer must be empty and off to enter the test mode.

1. Press and hold **NO SPIN** and **LIGHT SOIL LEVEL**.
2. Press **POWER**.
3. Press **START/PAUSE** to cycle through the test modes. (See chart.)

Number of times the Start/Pause button is pressed	Check Point	Display Status
None	Turns on all lamps and locks the door.	See Below
1 time	Tumble clockwise.	rpm (42~50)
2 times	Low speed Spin.	rpm (55~65) (X 10)
3 times	High speed Spin.	rpm (115) (X 10)
4 times	Inlet valve for prewash turns on.	Water level frequency (25~65)
5 times	Inlet valve for main wash turns on.	Water level frequency (25~65)
6 times	Inlet valve for hot water turns on.	Water level frequency (25~65)
7 times	Inlet valve for bleach turns on.	Water level frequency (25~65)
8 times	Tumble counterclockwise.	rpm (42~50)
9 times	Heater turns on for 3 sec.	Water temperature
10 times	Circulation pump turns on.	Water level frequency (25~65)
11 times	Drain pump turns on.	Water level frequency (25~65)
12 times	Off	-

CHECK SUMS

WM2277H* 1F:81	WM2077CW 1F:82
WM2177H* 1F:81	WM2677H*M 1F:61









CHECK THE WATER LEVEL FREQUENCY

The numbers shown in the display indicate the water level frequency. Divide the number in the display by 10 to get the reading in kHz.

ex. Display is 241, so the reading is 24.1 kHz.





ERROR DISPLAY

- Press START/PAUSE when an error code is displayed (except **PE**) and the machine will PAUSE.
- If the error code (**PE**, **tE**, or **DE**) is not cleared within 20 seconds, the machine will power OFF.
- Error code **FE** will NOT cause the machine to power OFF.
- Any error code not listed will power the machine OFF if it is unresolved after 4 minutes.







	ERROR	SYMPTOM	CAUSE
1	WATER INLET ERROR		<ul style="list-style-type: none"> • Correct water level (246) is not reached within 8 minutes after water is supplied or it does not reach the preset water level within 25 minutes.
2	UNBALANCE ERROR		<ul style="list-style-type: none"> • The load is too small. • The appliance is tilted. • Laundry is gathered to one side. • Non distributable things are put into the drum.
3	DRAIN ERROR		<ul style="list-style-type: none"> • Not fully drained within 10 minutes.
4	OVER FLOW ERROR		<ul style="list-style-type: none"> • Water is overflowing (water level frequency is over 213). ※ If  is displayed, the drain pump will operate to drain the water automatically.
5	PRESSURE SENSOR ERROR		<ul style="list-style-type: none"> • The SENSOR SWITCH ASSEMBLY is out of order.
6	DOOR OPEN ERROR		<ul style="list-style-type: none"> • Door not all the way closed. • Loose electrical connections at Door switch and PWB Assembly. • The DOOR SWITCH ASSEMBLY is out of order.
7	HEATING ERROR		<ul style="list-style-type: none"> • The THERMISTOR is out order.

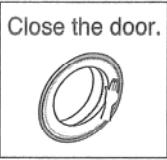

continued on next page

ERROR CODES, Continued

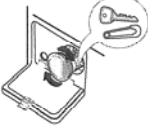
	ERROR	SYMPTOM	CAUSE
8	LOCKED MOTOR ERROR		<ul style="list-style-type: none"> • The connector (3-pin, male, white) in the MOTOR HARNESS is not connected to the connector (3-pin, female, white) of STATOR ASSEMBLY. • The electric contact between the connectors (3-pin, male, white) in the MOTOR HARNESS and 4-pin, female, white connector in the MAIN PWB ASSEMBLY is bad or unstable. • The MOTOR HARNESS between the STATOR ASSEMBLY and MAIN PWB ASSEMBLY is cut (open circuited). • The hall sensor is out of order/defective.
9	EEPROM ERROR		<ul style="list-style-type: none"> • EEPROM is out of order. <p>※ Displayed only when the START/PAUSE button is first pressed in the QC Test Mode.</p> <p>Try unplugging and plugging in again to reset the micro.</p>
10	POWER FAILURE		<ul style="list-style-type: none"> • The washer experienced a power failure.
11	COMMUNI- CATION ERROR		<p>Check all connections on the main board.</p> <p>Something is not plugged in correctly.</p>

DIAGNOSIS and CHECK LIST (Abnormal Operation)

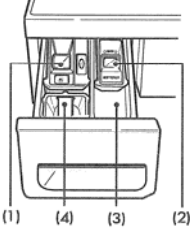
SYMPTOM	GUIDE FOR SERVICE CALL
<p style="text-align: center;">Door error</p> <div style="text-align: center;">  </div>	<div style="text-align: center;"> <p>Started with door opened?</p> <p>YES → </p> <p>NO ↓</p> <p>Close the door.</p>  </div> <div style="text-align: center; margin-top: 10px;"> <p>Was the load too large?</p> <p>YES → Avoid overloading.</p> <p>NO ↓</p> </div> <div style="text-align: center; margin-top: 10px;"> <p>Clicking sound is heard once or twice, when the START/PAUSE button is pressed to start the cycle?</p> <p>NO ↓</p> <p>Call for service.</p> <p>Check if the door switch is OK.</p> </div>
<p style="text-align: center;">Drain trouble</p> <div style="text-align: center;">  </div>	<div style="text-align: center;"> <p>Is  displayed?</p> <p>YES ↓</p> <p>Is the drain pump filter clogged with foreign material such as pins, coins, etc?</p> <p>YES → Clean the filter.</p>  <p>NO ↓</p> <p>Is the drain hose frozen, kinked, or crushed?</p> <p>NO ↓</p> <p>Call for service.</p>  </div>

SYMPTOM	GUIDE FOR SERVICE CALL
<p>Suds overflow from the appliance. (In this condition, wash and spin do not operate normally)</p>	<div style="display: flex; justify-content: space-between; align-items: center;"> <div style="width: 60%;"> <p>Is a HE (High Efficiency) detergent used?</p> <p style="text-align: center;">↓ YES ↓</p> <p>Is the proper amount of detergent used as recommended?</p> <p style="text-align: center;">↓ YES ↓</p> <p>Recommend to reduce the amount of detergent.</p> <ul style="list-style-type: none"> * This appliance has an automatic suds sensing function which prevents overflow. * When excessive suds are sensed, the suds removing implementations such as drain, water input, pause will operate, without rotating the drum. </div> <div style="width: 35%; text-align: center;">  </div> </div>
<p>Liquid laundry products do not flow in.</p>	<div style="display: flex; justify-content: space-between; align-items: center;"> <div style="width: 60%;"> <p>Is liquid laundry product put in the correct compartment of the dispenser?</p> <p style="text-align: center;">↓ YES ↓</p> <p>Is the cap clogged?</p> <p style="text-align: center;">↓ YES ↓</p> <p>Explain proper use of liquid laundry products.</p> <p>Clean the compartment.</p> </div> <div style="width: 35%; text-align: center;">  <p>(1) Liquid chlorine Bleach Compartment (2) Liquid fabric Softener Compartment (3) Prewash Compartment (4) Main Wash Compartment</p> </div> </div>
	<p style="text-align: center;">Call for service.</p>

FAULT DIAGNOSIS and TROUBLESHOOTING

NO POWER

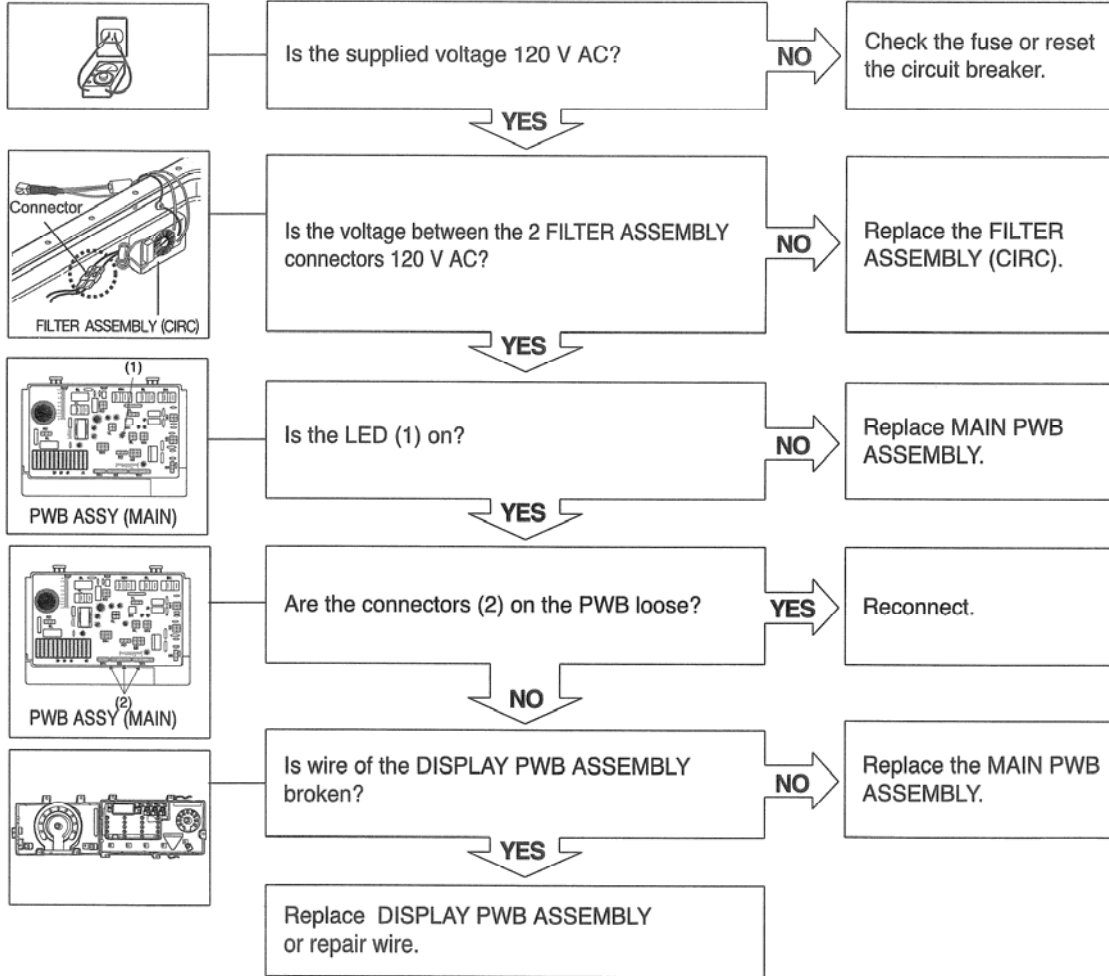

NOISE and VIBRATION DURING SPIN

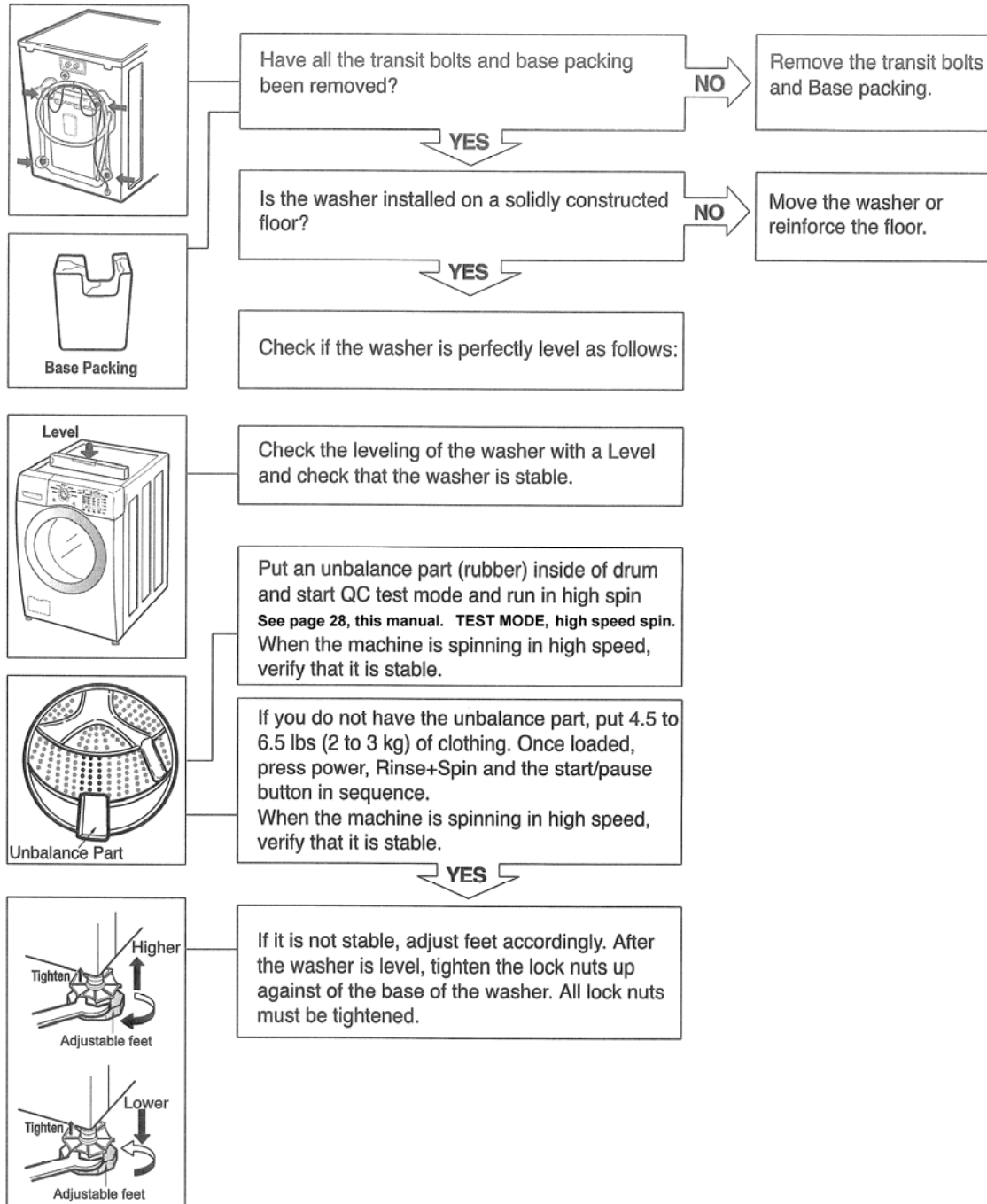

If the washer is properly leveled and there is still a vibration caused by resonance at a particular speed, see SpinSense on page 29 of this manual.

SPINSENSE

SpinSense is a software adjustment that allows a small adjustment in the spin speeds to eliminate excessive vibration, particularly vibration caused when the selected spin speed strikes a harmonic value in the floor and causes resonance.

To adjust the spin speeds to eliminate this issue, apply SpinSense using the following steps. Also refer to the **QC Test Mode** on page 22 and **Troubleshooting Noise and Vibration** on page 28 of this manual. Be sure the washer is correctly installed and leveled.

1. The washer must be running (in any cycle) to operate the SpinSense control. It must be past the load-sensing portion of the program.
2. The selected spin speed will have an LED lit in the button.
3. Press and hold the **SpinSense** button for over three seconds. (It is the Stain Cycle button on the right end of the control panel.) You will hear two quick beeps when the button is pressed and a long beep when the control takes effect.
4. The spin button of the selected cycle will blink if SpinSense is turned on. If the spin speed button is not blinking, SpinSense is turned off.
5. Turning SpinSense on affects all spin speeds for all cycles.

The SpinSense control is a non-volatile toggle. If you turn it ON or OFF, it will remain in that state until it is changed by following the steps above. Activating SpinSense should resolve 95% of all vibration issues. It will NOT solve the problem of a shaky, loose, or poorly constructed floor.

NO WATER SUPPLY

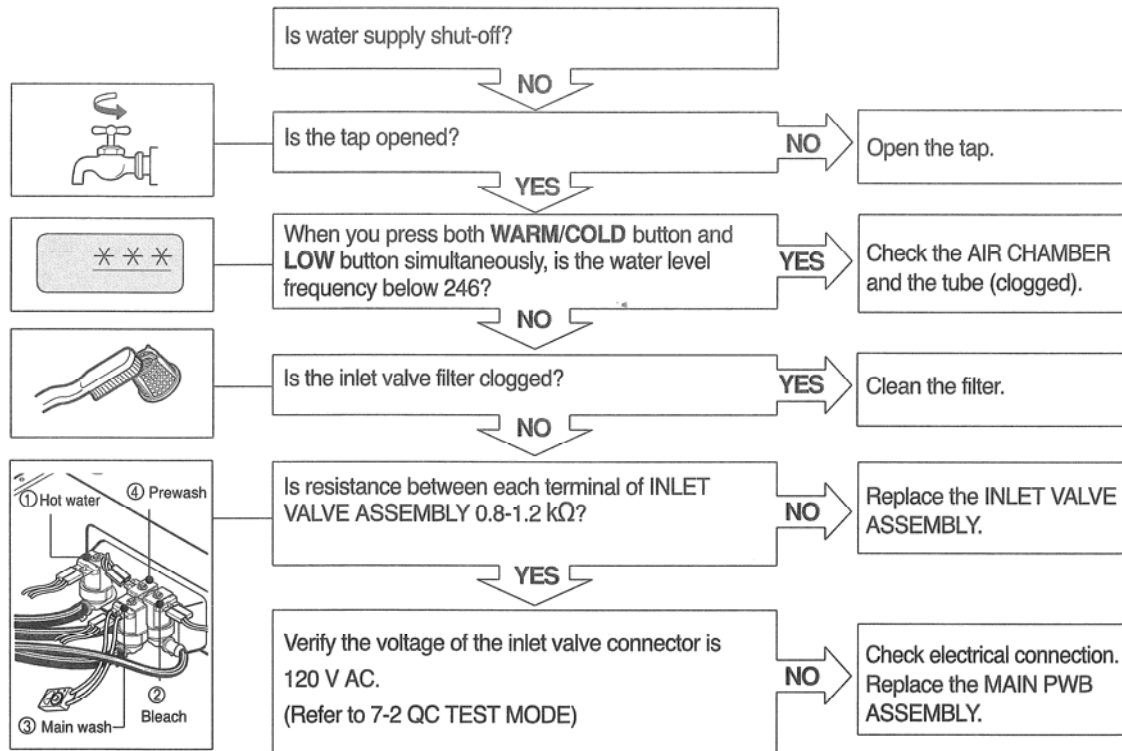

DETERGENT DOES NOT FLOW IN

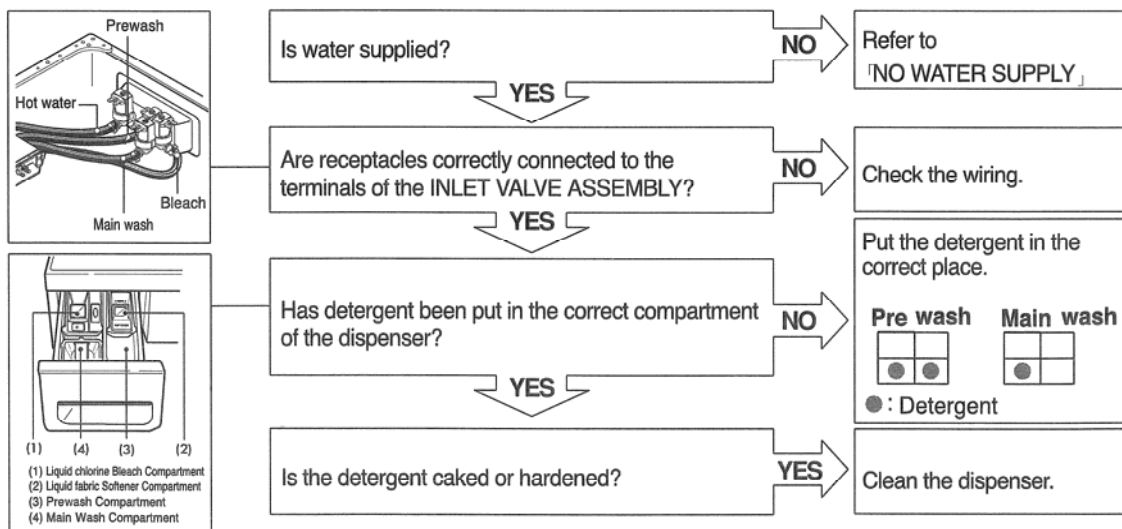

(See DISPENSER, page 20.)

LIQUID SOFTENER and BLEACH DO NOT FLOW IN

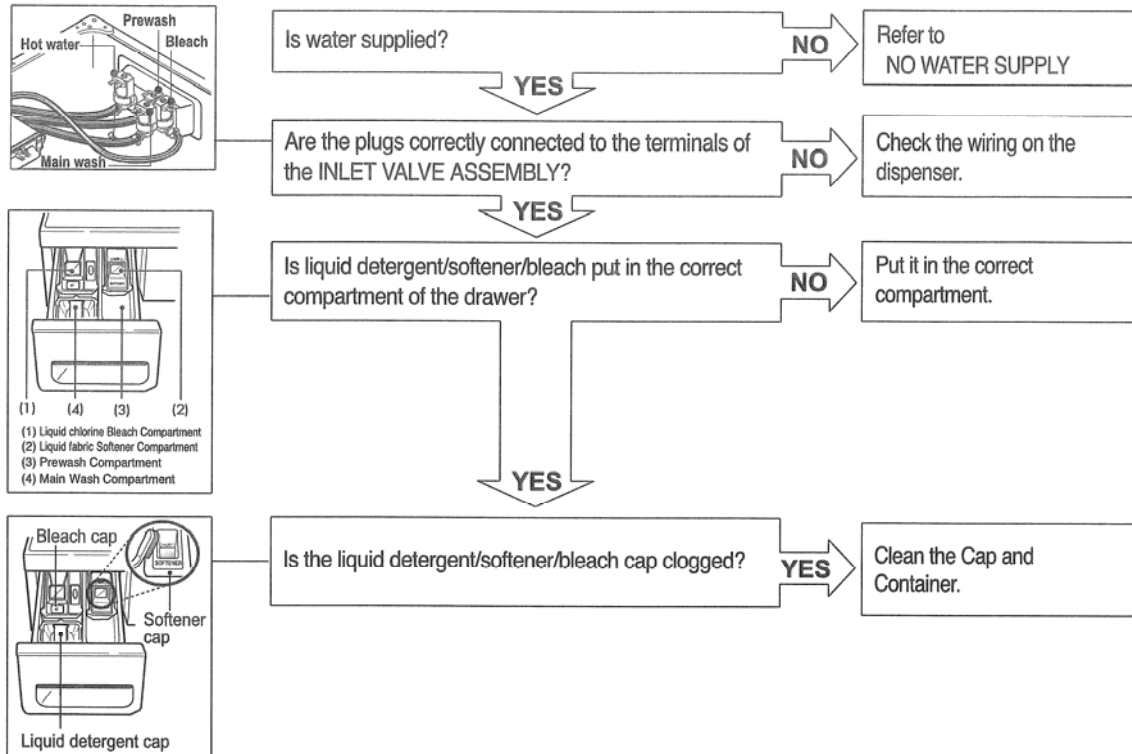

(See DISPENSER, page 20.)

ABNORMAL SOUND

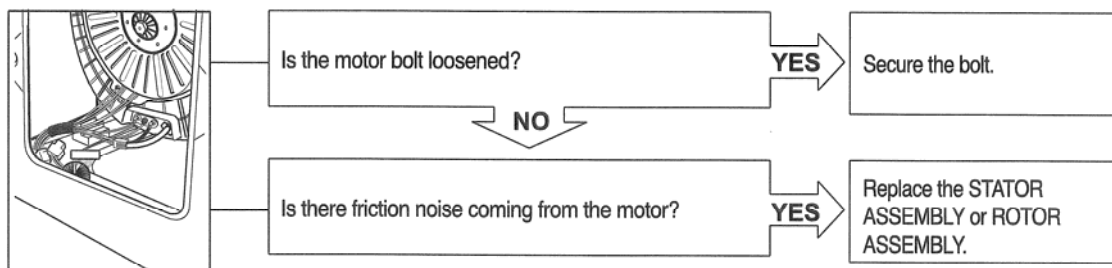

HEATER OPERATION WITHOUT WATER

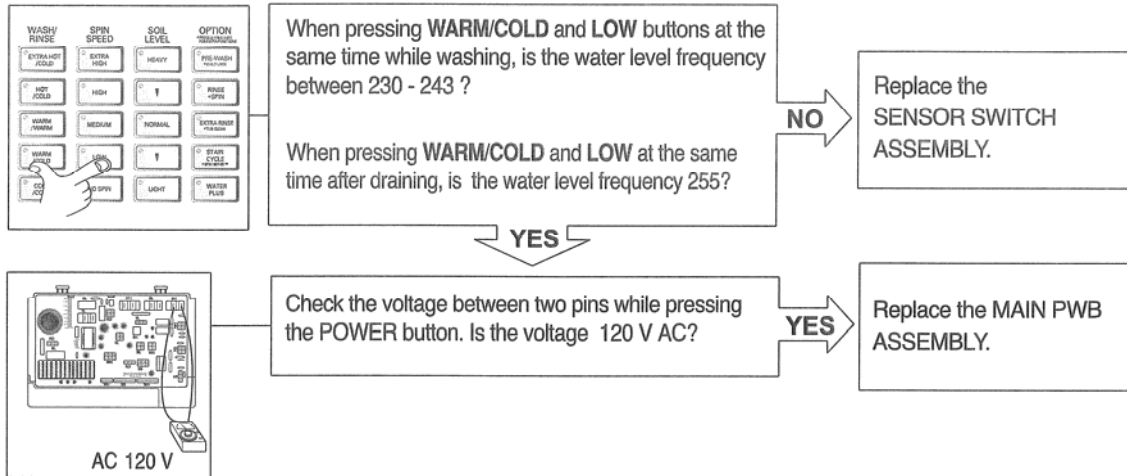

DRAIN MALFUNCTION

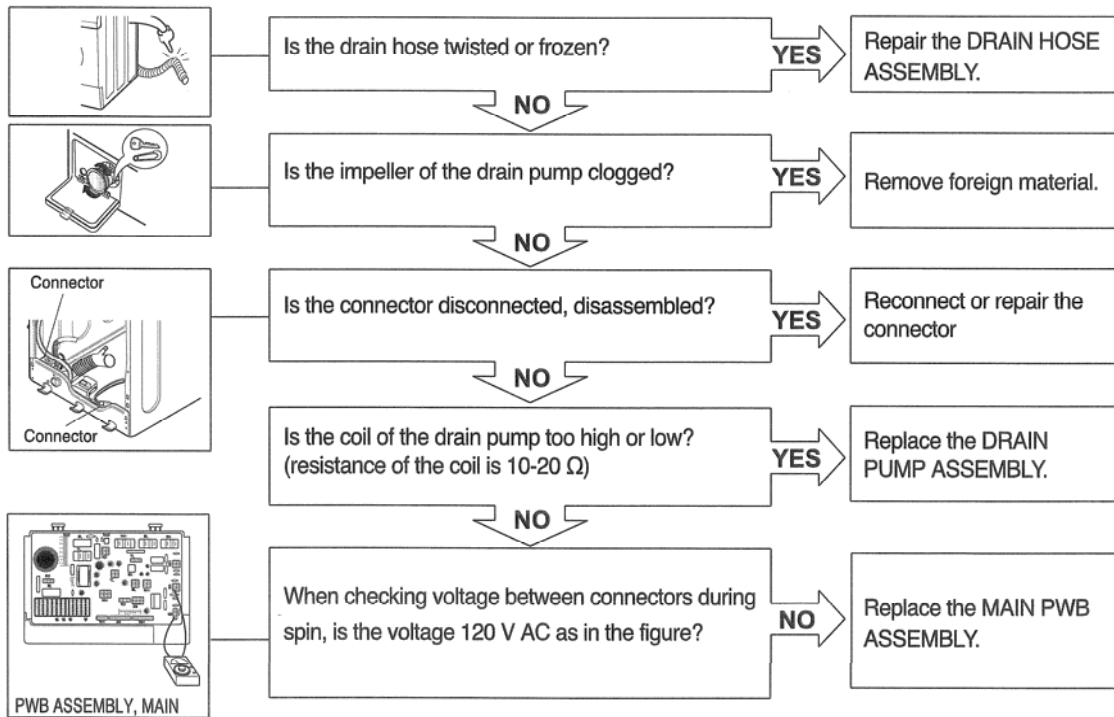

WASH HEATER MALFUNCTION

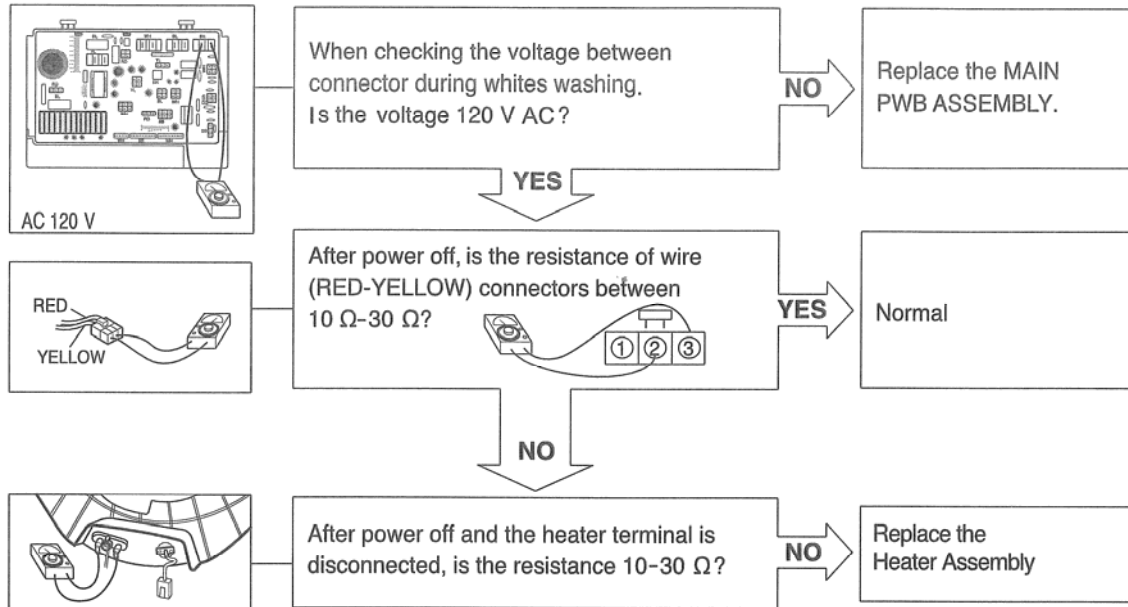

HEATER MALFUNCTION (CONTINUOUS OVERHEATING)

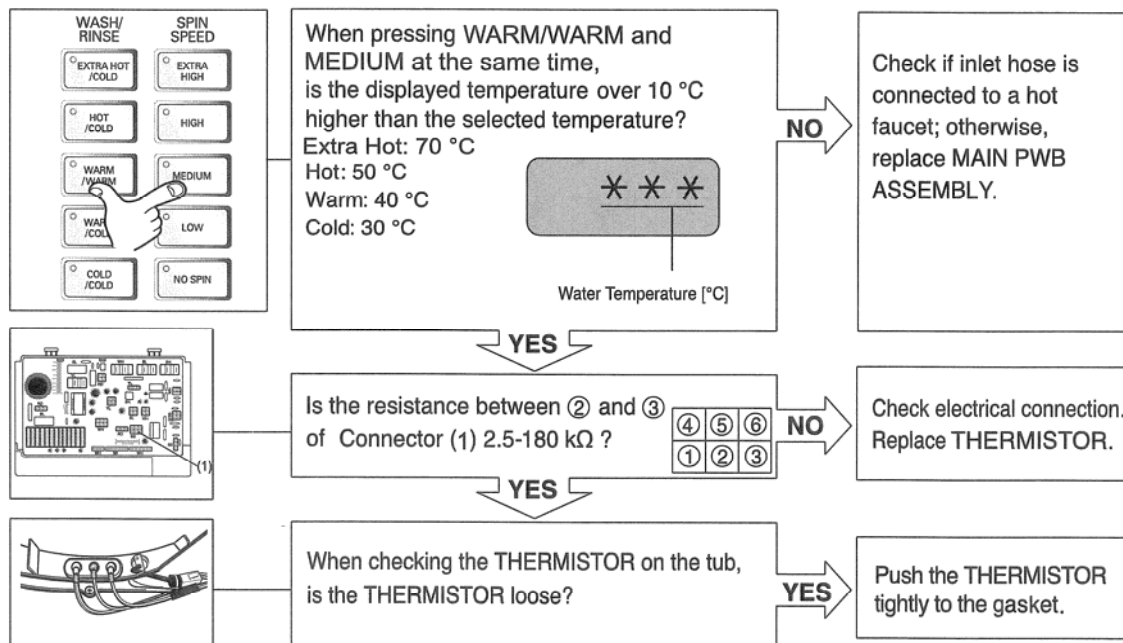

NO WATER CIRCULATION

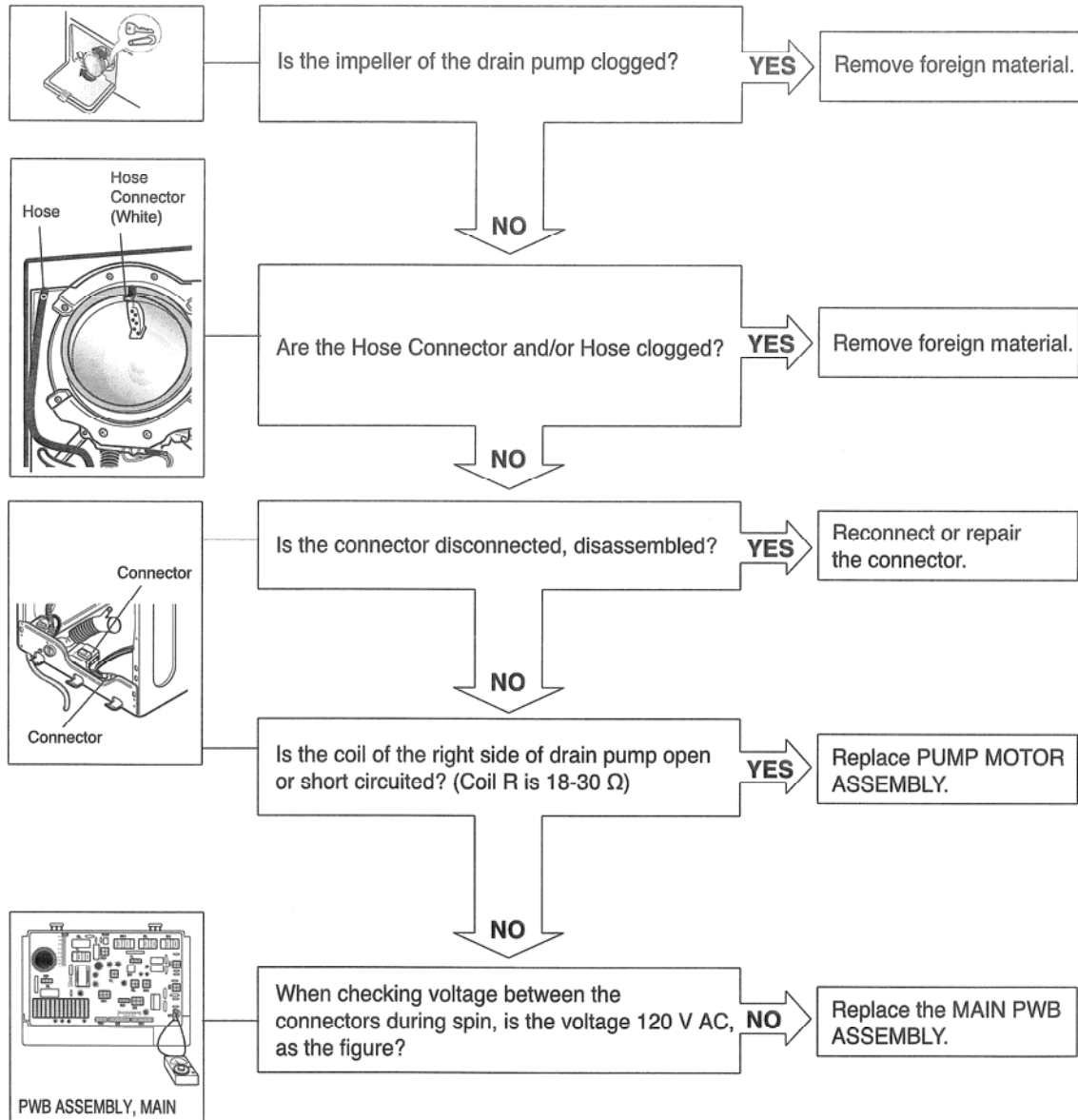

SPIN MALFUNCTION

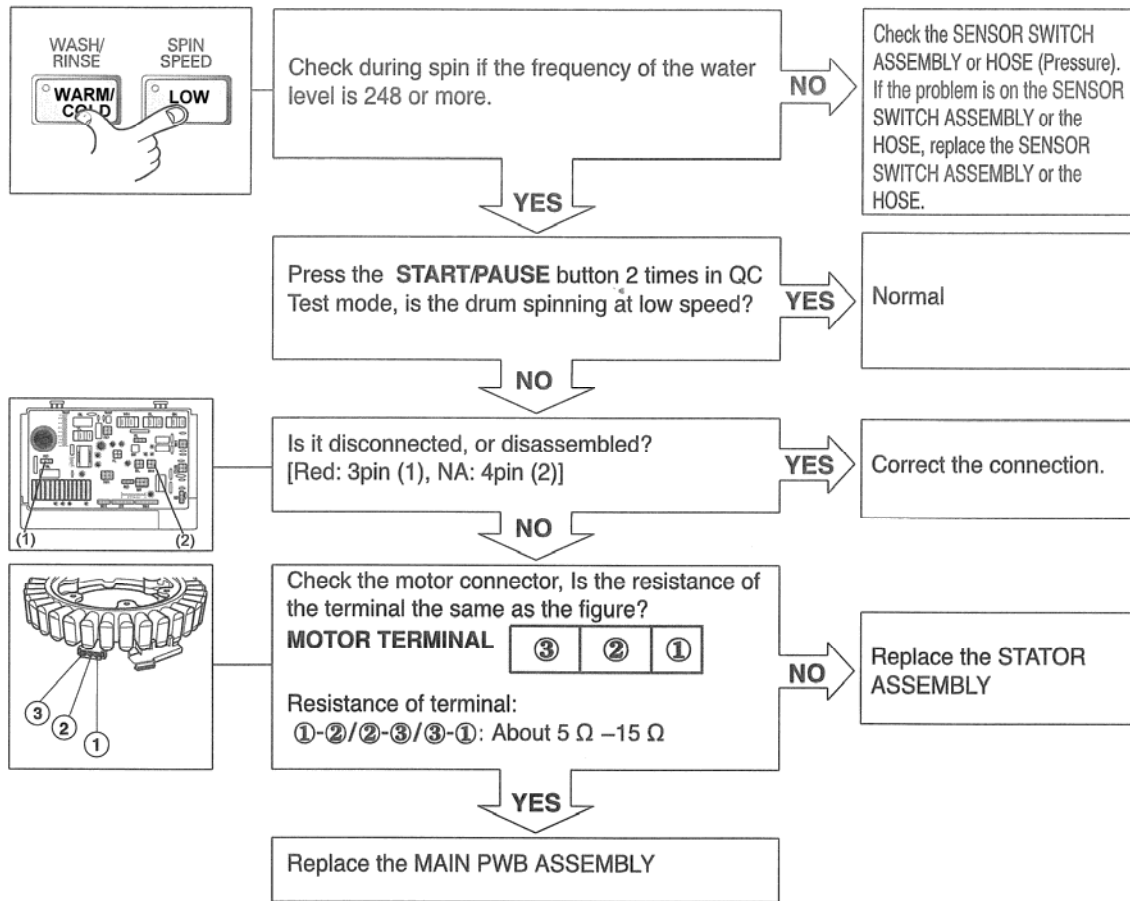

dE ERROR CODE

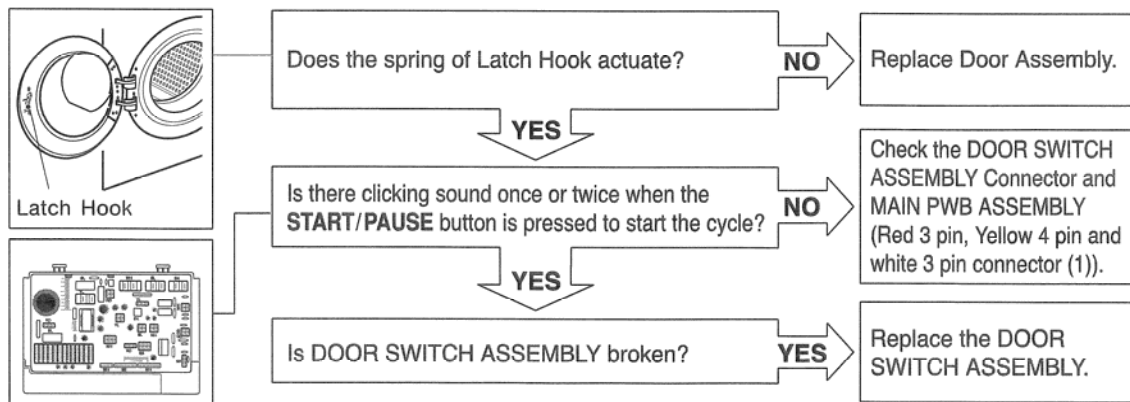

DISASSEMBLY and REPAIR

The following pages will show the instructions for disassembly, repair, replacement of parts, and re-assembly. Many times, electrical components may be tested by connecting the appropriate meter to the leads or connectors on the main PC Board. (Refer to the block wiring diagram, below.) Proper diagnosis will eliminate unnecessary labor and expedite repairs.

BLOCK WIRING DIAGRAM

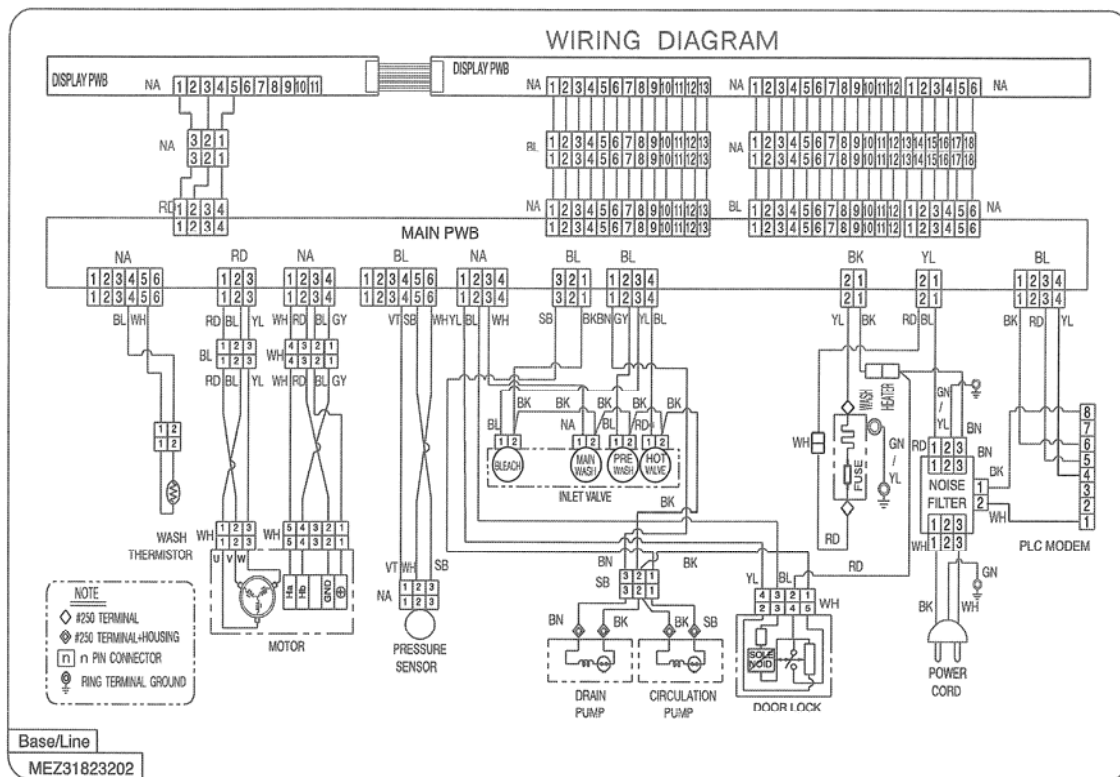

DISASSEMBLY/REPAIR (Control Panel)

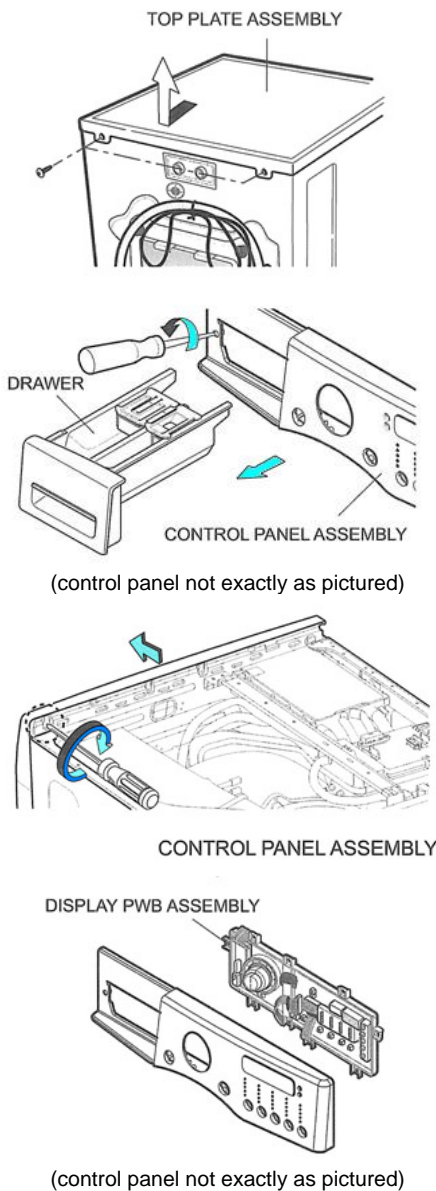

1. Remove two screws on the back of the top plate.
2. Pull the top plate backward and lift, as shown.
3. Remove the detergent drawer.
4. Remove two screws behind the detergent drawer.
5. Disconnect the connector for the Display PWB.
6. Remove one screw from the corner of the control panel.
7. Lift the top away from the support rail and pull the control panel up and away to remove.
8. Remove eight screws to separate the control panel and PWB.
9. Reassembly is the reverse of these steps.

DISASSEMBLY/REPAIR (Main Board)

Often, you can diagnose a failed part by removing its connector on the main board and connecting the tester to the leads in the connector. (See page 51.)

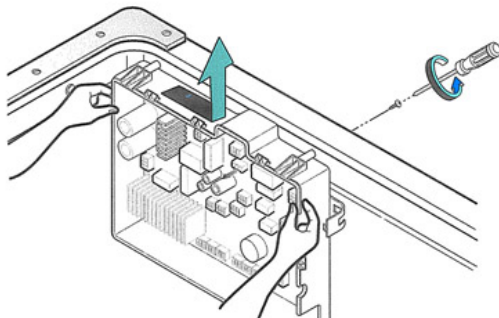
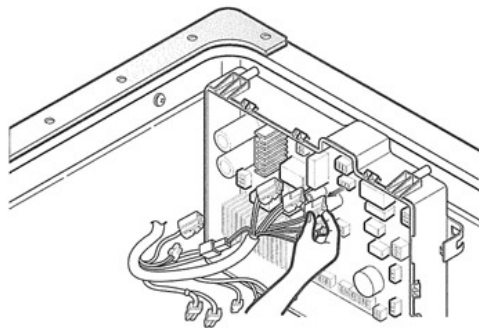
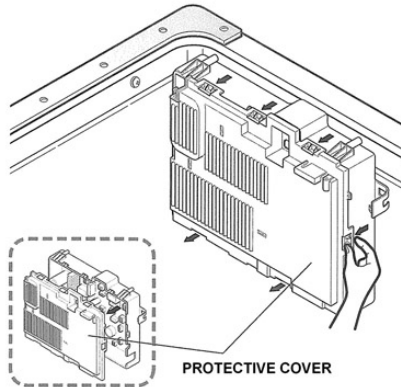

1. Disconnect the POWER connector and the Water Level Sensor Switch.
2. Remove the protective cover. Press the plastic tabs out of the way to remove the cover. The main board is potted, so no repairs to it are possible. You can remove connectors to test various components without having to disassemble the washer at this point. To continue, remove the pressure sensor and wire holders on the cover and set it aside.
3. Disconnect the connectors on the main board. They are all different, keyed, and color-coded to prevent incorrect connection.
4. Pull the wires out of the way.
5. Remove one screw on the back of the washer to release the main board housing.
6. Remove the main board by sliding it to the right and lifting it up. Press it to the back and left to replace it.

DISASSEMBLY/REPAIR (Dispenser)

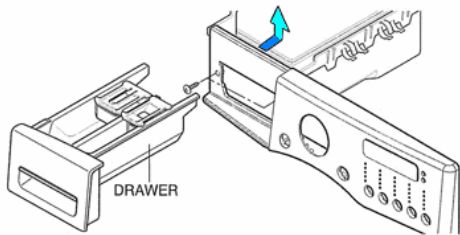

(control panel not exactly as pictured)

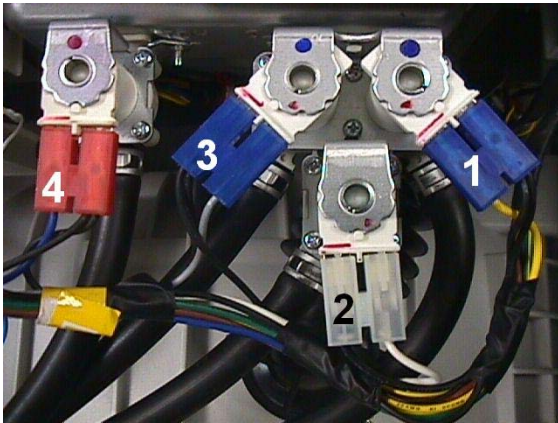
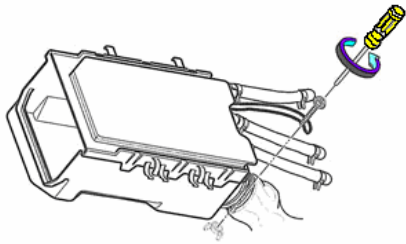

1. Remove the top plate.
(See page 37.)
2. Remove the dispenser drawer.
3. Remove two screws to release the dispenser.
4. Loosen the clamp on the large hose that runs from the dispenser to the drum.

Have an old towel handy to stuff under the dispenser to soak up any spillage.
5. Disconnect the connector from the solenoid. Make a note of the color codes and connections.

#1 Blue; yellow and black wires
#2 White; white and black wires
#3 Blue; gray and black wires
#4 Red; blue and black wires (hot)
6. Remove two screws from the back of the cabinet

DISASSEMBLY/REPAIR (Noise Filter)

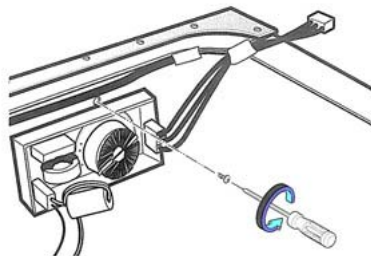

1. Remove the connectors from the noise filter.
2. Remove the screw from the top bracket.

DISASSEMBLY/REPAIR (Front Cabinet Cover)

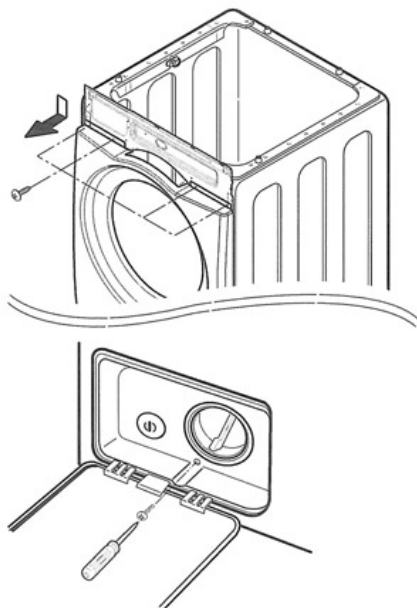

1. Remove the top plate.
(See page 37.)
2. Remove the control panel.
(See page 37.)
3. Remove four screws that secure the front panel.
4. Remove the screw that secures the filter cover.



5. Use a flat screwdriver or a putty knife to loosen the filter cover and pull it out. Stick the screwdriver into the cover slot and pry it out sideways to free it.

Then remove the screw behind the drain cover so you can lift the front cover off the machine.



6. Drain the sump by pulling out the little hose by the filter cover. Let the water (maybe as much as a quart) drain into a shallow pan. Don't pull the hose out so far you kink it or the water will not flow.

Some servicers carry an old water or soft drink bottle in their toolbox for this purpose.

DISASSEMBLY/REPAIR (Front Cabinet Cover, continued)



8. Open the door.
9. Remove the clamp using special tool 383EER4001A. (See page 58.)

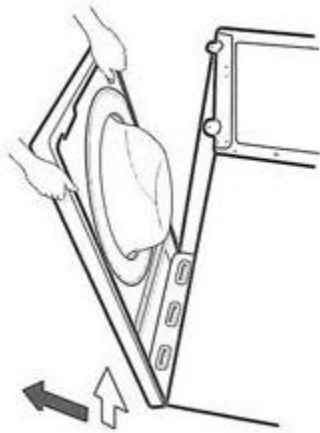

10. Lean the cabinet front forward, being careful to avoid breaking the glass. The door is HEAVY.
11. Disconnect the door switch connector. (Remember to reconnect it upon reassembly.)
12. Lift the door and front cover off the cabinet base as an assembly. Lay it face down on a blanket or some other protective surface.

DISASSEMBLY/REPAIR (Door)

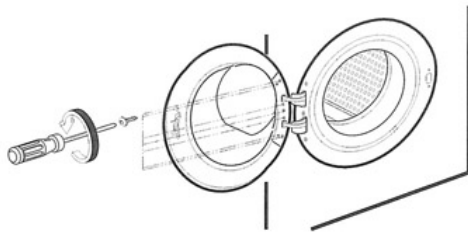

Remove the door with the front cover still on the machine.

1. Open the door.
2. Remove seven screws from the hinge cover.
3. Pry off the hinge cover with a flat screwdriver.
4. Remove the screw at the bottom of the hinge.
5. Lift the door off the hinge.

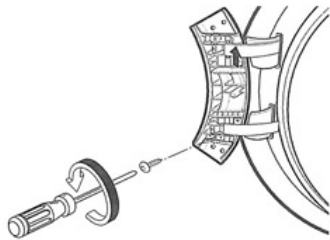
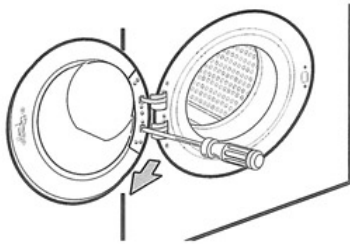

CAUTION! The door is HEAVY!

DISASSEMBLY/REPAIR (Door switch removal)

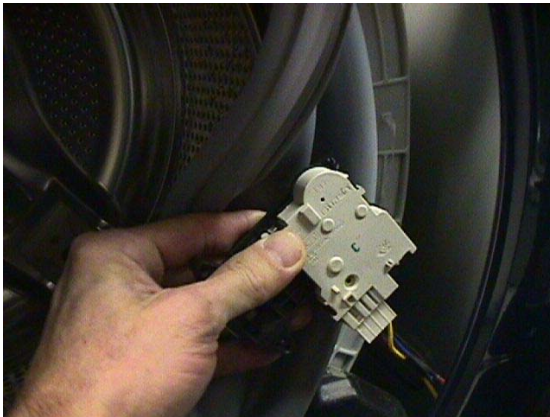

1. Open the door.
2. Remove the gasket clamp using special tool 383EER4001A. (See page 58.)
3. Remove the two screws holding the switch.
4. Push the gasket aside to remove the switch.
5. Unplug the switch to change it.
6. Make sure the wires don't fall back in before you can replace the switch.

DISASSEMBLY/REPAIR (Pumps)

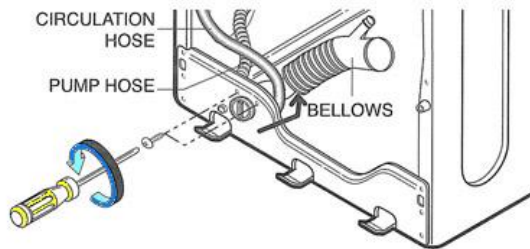

1. Remove the front cabinet. (See page 40.)
2. Drain the water from the sump. (See page 40.)
3. Remove the clamps and hoses.
4. Remove two screws and push the pump backward and up.
5. Press down the plastic tab on the base to slide the pump assembly backward.



This tab is for the convenience of the workers in the assembly plant. It holds the pump in place while the machine is being built. If you break it, don't worry about it.



6. You can tilt the pump in either direction to remove/replace the individual pumps without having to remove the tub.

Have a towel handy to catch the spillage.

DISASSEMBLY/REPAIR (Heater)

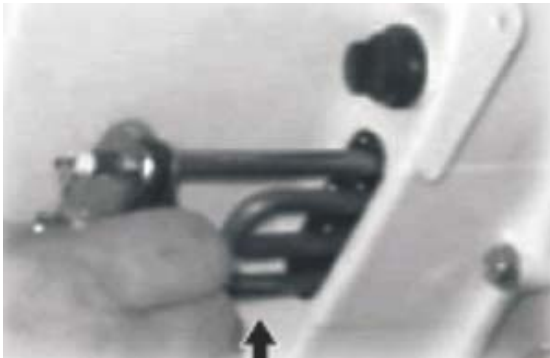

1. Remove the front cabinet. (See page 40.)
2. Drain the water from the sump. (See page 40.)
3. Remove the push-on connectors from the heater. There may be a hidden release on the terminals.
4. Remove the nut that holds the ground wire. Then loosen but **do not remove** the nut that secures the heater clamp and pull the heater out. You may have to wiggle it to release the gasket.

Be sure to pull the heater element **STRAIGHT** out to avoid damaging it.

DISASSEMBLY/REPAIR (Thermistor)

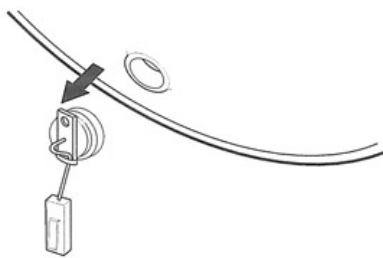

1. Remove the front cabinet. (See page 40.)
2. Drain the water from the sump. (See page 40.)
3. Unplug the white connector.
4. Hold the bracket and pull the thermistor out.

DISASSEMBLY/REPAIR (Object between tub and drum)

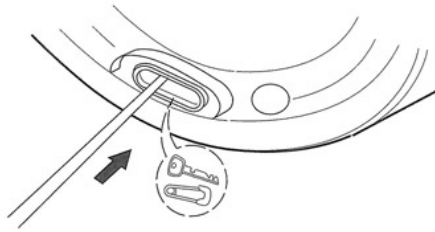

1. Remove the top cover. (See page 37.)
2. Remove the front cabinet cover. (See page 40.)
3. Remove the heater. (See page 44.)
4. Fish out the foreign object(s) using a wire or bar.

WATER LEVEL SWITCH

The water level detector switch monitors the water level and feeds this information to the MICOM. The sensor reads air pressure in an air chamber on the tub. The air pressure changes in relation to the depth of the water, moving a diaphragm in the switch. As the water level fluctuates, it raises or lowers the iron center in the coil, which, in turn, changes the electric resonance of the oscillator circuit of which it is a part. As water level decreases, frequency increases. (e.g. A low water level may read 25.5 kHz, while a high water level may read 21.4 kHz. These readings are approximate; washers in the field may vary slightly from these figures.)

To read the frequency while the WM2496 is running, press and hold the **LOW SPIN** and **LIGHT SOIL** buttons simultaneously. The number on the display should be divided by 10 to obtain the frequency reading in kHz. A display of 254 would indicate a frequency of 25.4 kHz. The MICOM interprets the frequency reading as one of eight levels, with one being the lowest water level and any level greater than eight indicating an overflow situation.

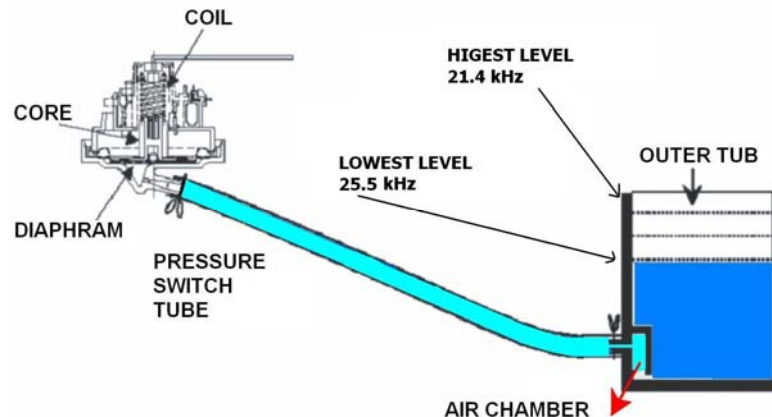

DISASSEMBLY/REPAIR (Motor)

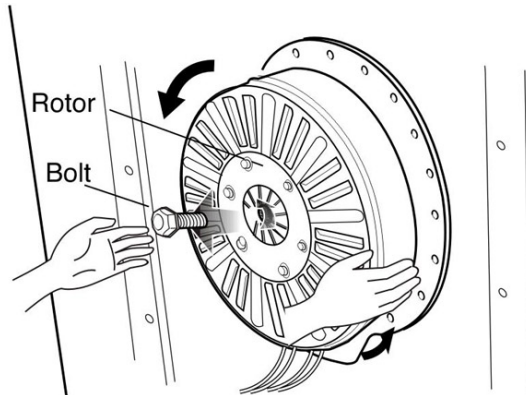

For technical information concerning the direct drive DC motor, refer to page 47.)

1. Remove the back cover.
2. Remove the large bolt in the center shaft. (Your helper can hold the inside of the drum.)

DO NOT stick a screwdriver through the slots in the rotor.

3. Pull the rotor off the shaft.

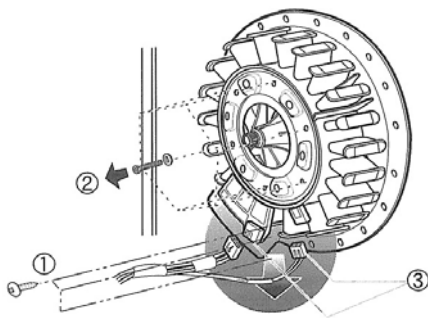

1. Remove two screws from the tub bracket.
2. Remove six bolts on the stator.
3. Unplug two connectors on the stator.
4. Pull the stator off the shaft.

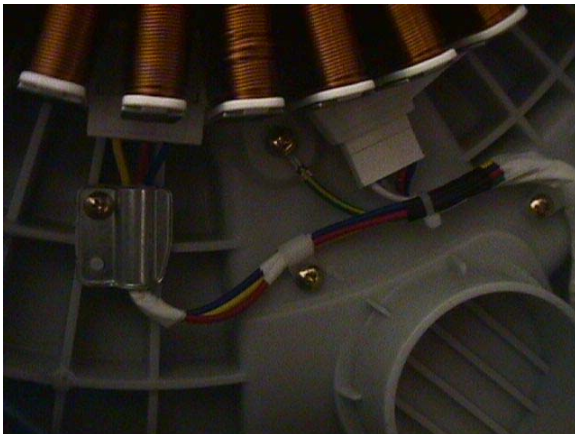

5. When re-installing, the clamps and the ground screw must be installed and the connectors pressed into place before the rotor is bolted onto the shaft.

DIRECT DRIVE MOTOR



The motor is a direct-drive, brushless, DC motor. It is attached to the drum via a splined shaft, eliminating belts, pulleys, transmissions, and the inherent problems associated with them. The rotor is attached to the shaft by one large bolt.

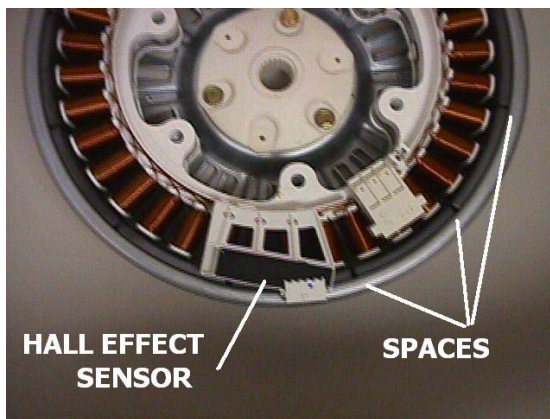

The DC motor can be driven from stopped to maximum speed in infinite steps in either direction. There are 36 poles on the stator and 12 permanent magnets spaced around the rotor. There are no brushes to wear out. Unlike a more traditional brushless motor, the rotor surrounds the stator rather than being attached to it.

A Hall Effect sensor determines the speed and direction of the motor. It also can read that the load is off balance when the drum speed fluctuates, eliminating the ball sensor found on previous models.

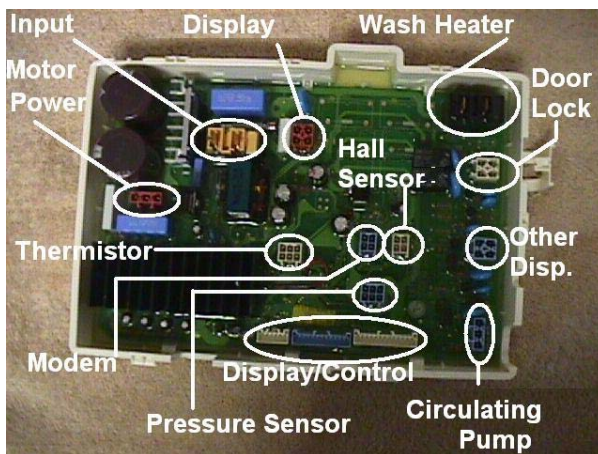

Before going to this trouble, check the connector on the main board. It is the red connector closest to the heat sink. Pull the connector off and verify the board is receiving a signal from the sensor.

DISASSEMBLY/REPAIR (Tub and Drum)

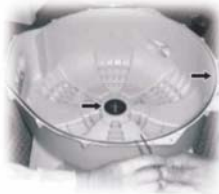

Removing the tub/drum assembly is major surgery. It is much lighter if you remove the weights and the motor. Generally speaking, you'll have to remove all that anyway.

1. Remove the motor.
(See page 46.)
2. Drain the water from the sump.
(See page 40.)
3. Remove the control panel.
(See page 37.)
4. Remove the front cabinet.
(See page 40.)
5. Disconnect all hoses and electrical connections.
6. Separate the three dampers.
(See page 49.) You can remove just one end of each damper now and the other one after the drum is out.
7. Pry apart the spring retainer clip. (See photo, left.)
8. Carefully lift the tub up off the springs and remove it from the machine.
9. Unbolt the bolts around the circumference of the seam. Separate the halves. Be careful to avoid damaging the gasket. Do not pry on the surfaces between the halves.

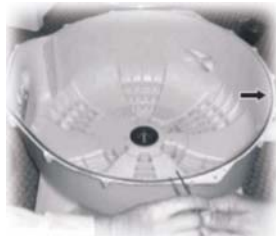

DISASSEMBLY/REPAIR (Damper)



1. Disconnect the dampers from the tub and the base.
(See photos, left.)

Be sure to press in the safety tab before pushing the pin out of the damper. You can use a $\frac{9}{16}$ " socket to hold the pin in while you squeeze the pin with the special tool 383EER4003A. (See page 58.)



2. The flat end goes on the small end and the split end allows the head end to pass through while the pin is pushed out.

The color and/or appearance of the dampers may vary by model.

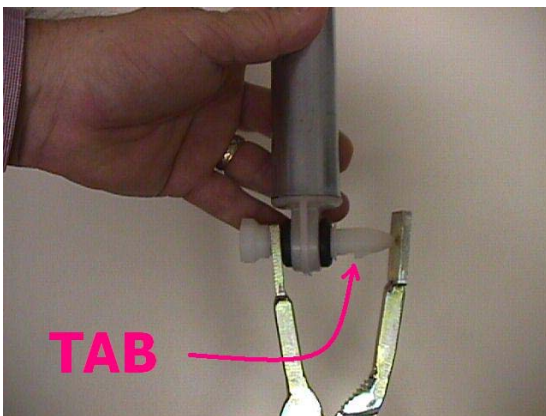

3. Use special tool 383EER4003A to remove the damper pins. If you are replacing the dampers, you'll have to remove both ends. If you are removing the tub for major repair work, disconnect the damper ends at the base and leave the other ends connected until you remove the tub. When putting the tub back into the machine, connect the dampers to the tub first. It is much easier that way.
4. Be careful not to pull the dampers apart while they are disconnected from the machine.

TIPS and TRICKS



HOSES

When replacing the large hoses, be sure to avoid getting the lip turned under the hose clamp. This will damage the hose and cause a leak. The large hoses have notches on the ends to index them on the connectors. Be sure the notch is pushed down all the way on the index boss.



BAFFLES

You can replace the baffle and rollers without having to remove the drum. Unscrew the retaining screw at the back of the baffle. Slide it toward the front of the washer to remove it. You can unscrew the retainer inside the baffle to replace the roller balls.



MUSHROOM VALVES

Be sure the mushroom is in place before attaching the hose. If the stem is too long, it will contact the drum and make significant noise when the drum turns. You can trim it if necessary.

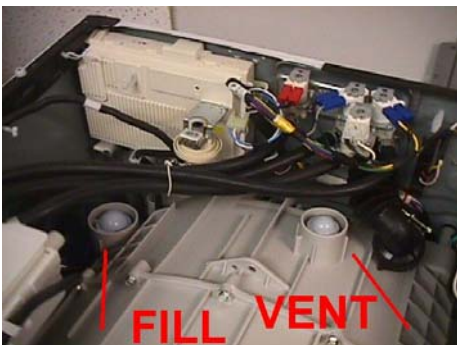

The valves are not shown on the exploded view. There is one in the fill tube and another in the vent tube. Part numbers are included in the parts list.

The valves are NOT interchangeable. Order by model and part number.

4769ER4001A	Vent valve
4769ER4002A	Fill valve

WIRING DIAGRAM

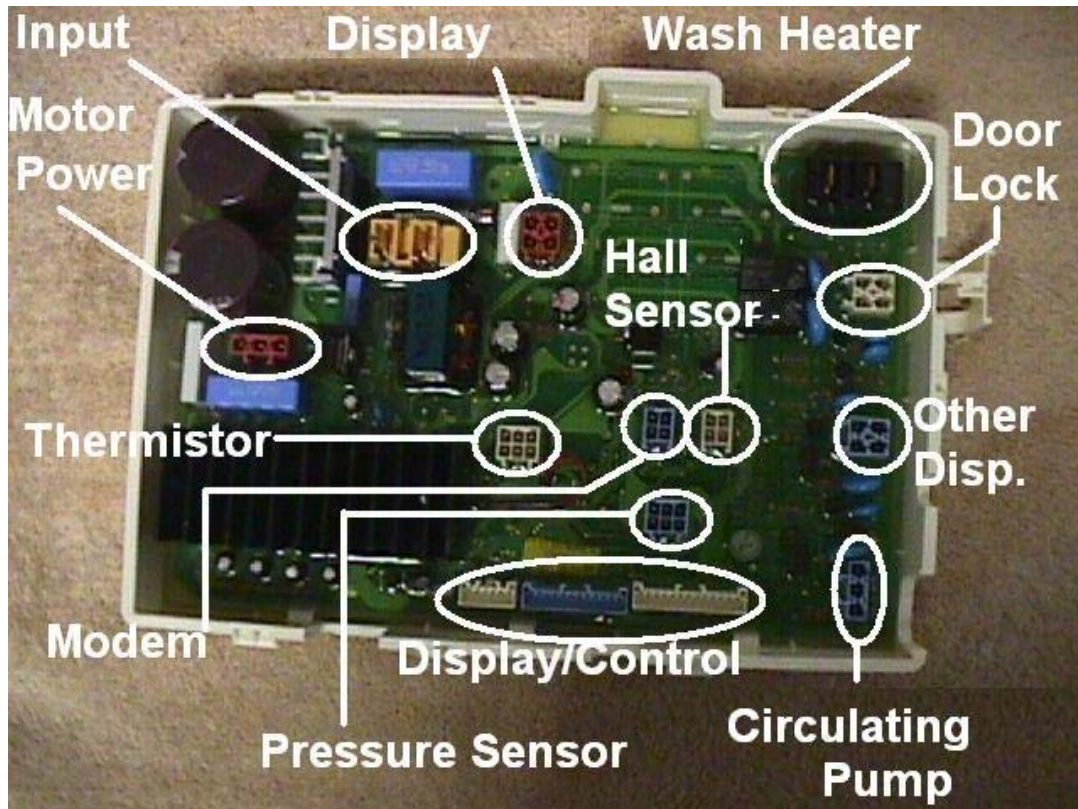
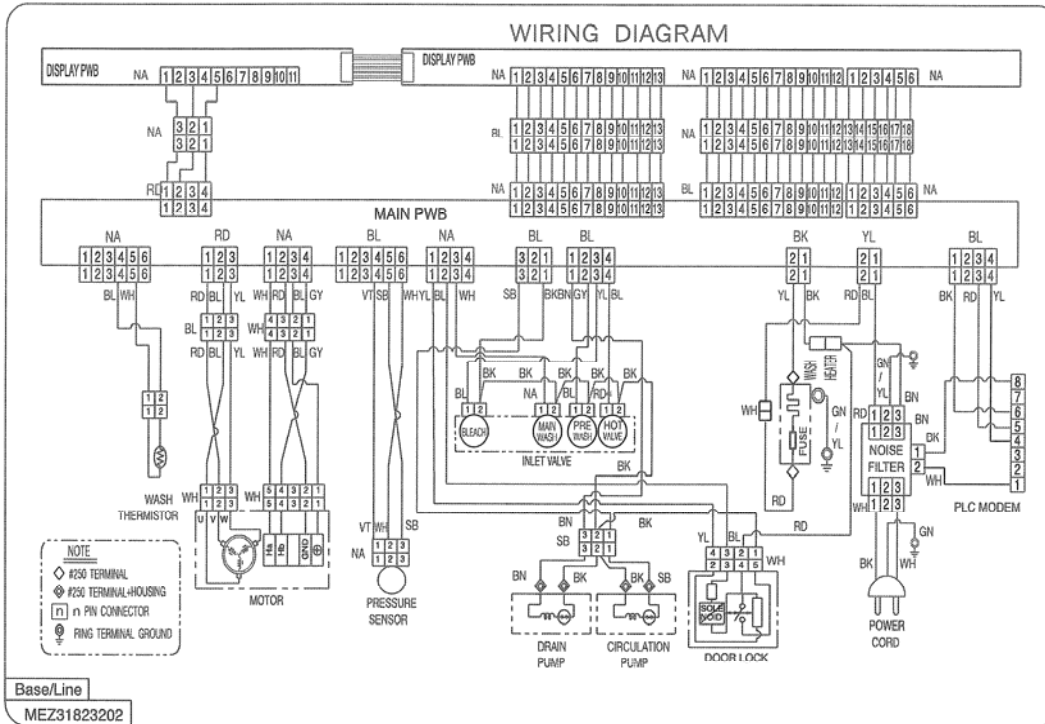

EXPLODED VIEW – Cabinet and Control Panel

Control panel, dispenser drawer, and front panel not exactly as pictured. Drawing to be updated when available.

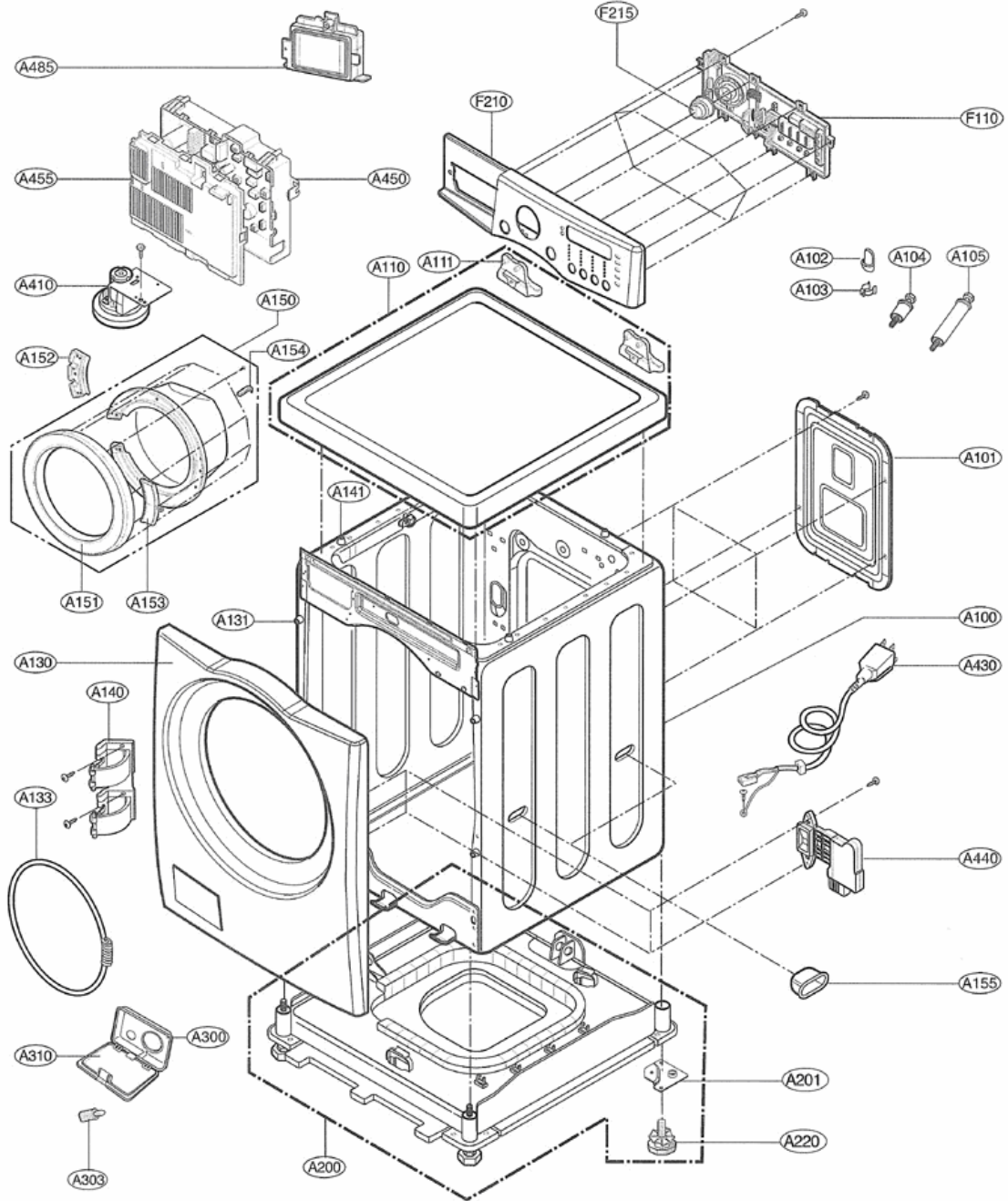

EXPLODED VIEW – Dispenser Assembly

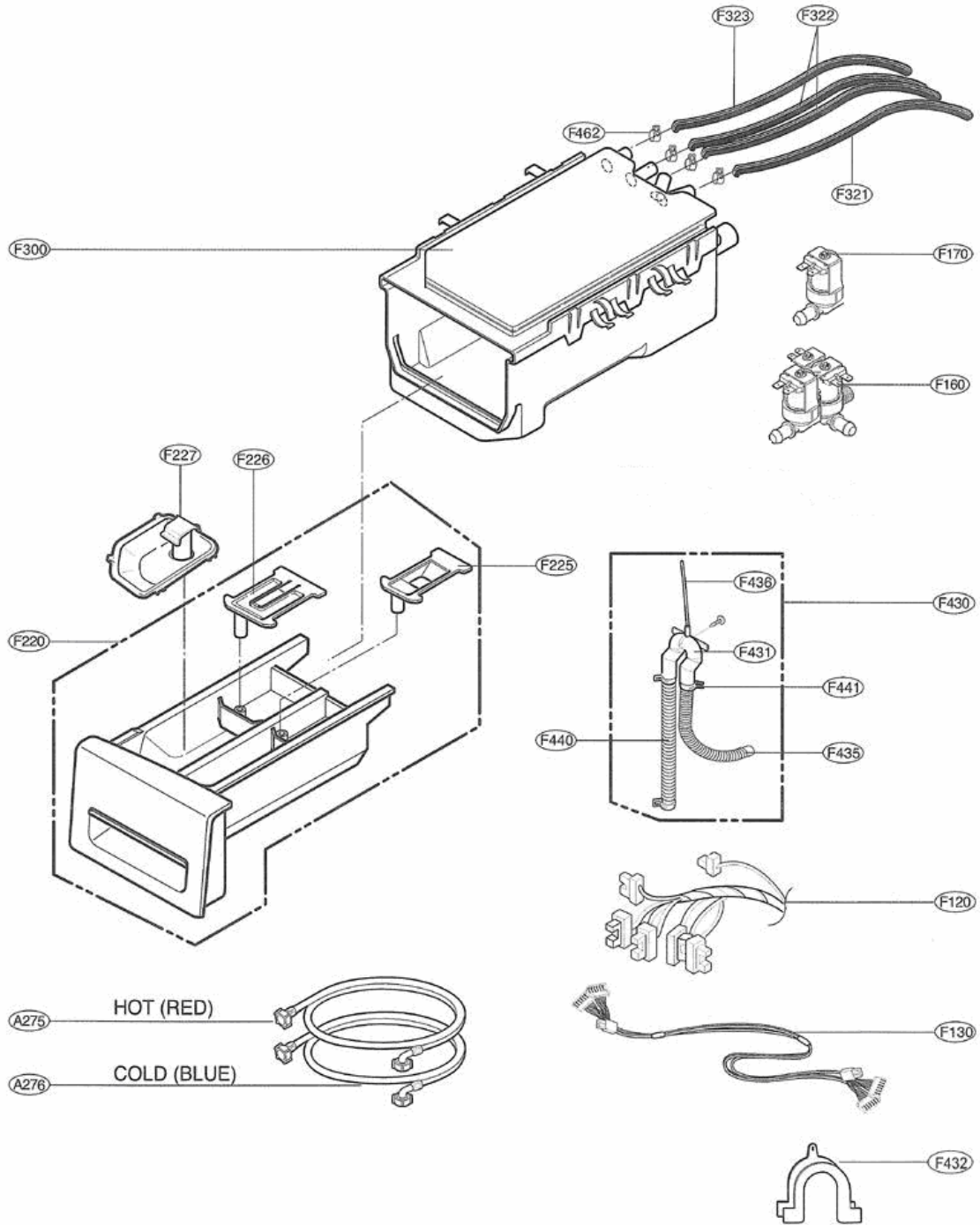

PARTS LIST

Loc #	Part No	Description
	AFN30385101	Owner's Manual
	3890EZ3612A	Outer Box (Carton)
	3W20018B	Wrench (See page 58)
	MFL30599101	Service Manual
A100	3091ER0004P	Cabinet Assembly
A101	3550ER1028A	Rear Cover
A102	4830ER3001A	Bushing
A103	4930ER3014A	Holder
A104	4011FR3159E	Shipping Bolt, Upper (Short) (2)
A105	4011FR3159D	Shipping Bolt, Lower (Long) (2)
A110	3457ER1006C	Top Plate Assembly
A111	4810ER3021A	Hinge
A130	3550ER0045A	Front Cabinet Cover
A131	4930ER4005A	Guide
A133	2W20017E	Gasket Clamp
A140	4775ER2002A	Hinge Assembly
A141	4930ER4018A	Guide
A150	3581ER1008J	Door Assembly
A151	3212ER1023A	Door Frame, Inner
A152	3212ER1016A	Door Frame, Outer
A153	3650ER2004B	Door Handle
A154	4026ER4004A	Door Latch Hook
A155	3650FA3488M	Hand Hold Cover (4)
A200	3041ER0001C	Base Assembly
A201	4810ER3006A	Base Leg Bracket
A220	4779ER3002A	Leg Assembly
A275	5215FD3715J	Inlet Hose (Hot, Red)
A276	5215FD3715K	Inlet Hose (Cold, Blue)
A300	3110ER2016A	Case, Drain
A303	5006ER3009A	Drain Assembly, Plug
A310	5006ER2012A	Drain Cover
A410	6601ER1006E	Switch Assembly, Water Level
A430	6411ER1005K	Power Cord Assembly

Loc #	Part No	Description
A440	6601ER1004C	Door Switch/Lock
A450	6871ER1104A	Main PCB
A455	3550ER1032A	Main PCB Cover
A485	6201EC1006B	Line Noise Filter
F110	6871ER2089A	Display PCB
F120	6877ER1044D	Display Wiring Harness
F130	6850ER2002C	Flat Cable
F140	6877ER1016F	Wiring Harness
F145	6877ER3003B	Wiring Harness
F160	5221ER1003A	Inlet Valve, Cold (Triple)
F170	5220FR2006H	Inlet Valve, Hot (Single)
F210	3721ER1317A	Control Panel
F215	4941ER3002A	Control Knob
F220	3721ER1316A	Dispenser Drawer Assembly
F225	5006ER3014B	Siphon Cap, Softener
F226	5006ER3018A	Siphon Cap, Bleach
F227	3891ER2003A	Siphon Box, Detergent (Liquid)
F300	4925ER1015B	Dispenser Assembly
F310	4738ER1004B	Bellows, Water Input
F315	4738ER2002A	Bellows, Air Vent
F321	5214ER4001A	Inlet Hose
F322	5214ER4001B	Inlet Hose
F323	5214ER4001J	Inlet Hose
F430	5215ER2002G	Drain Hose Assembly
F431	4932FR3156A	Drain Hose Connector (Vacuum Break)
F432	3W50712A	Drain Hose Hanger
F435	5214FD3663E	Drain Hose, Vacuum Break to Drain
F436	5214FR4125S	Inlet Hose, Vacuum Break to Tub
F440	5214FR3188K	Drain Hose, Pump to Vacuum Break
F441	4861FR3068C	Clamp
F461	4861FR3068E	Clamp
F462	4861FR3068A	Clamp
F463	4860FR3092D	Clamp
F464	4860FR3092C	Clamp
F465	4860FR3092D	Clamp
F466	4861FR3068E	Clamp
F467	4860FR3092C	Clamp
F468	4861FR3068E	Clamp

Loc #	Part No	Description
--------------	----------------	--------------------

K105	3045ER0048B	Outer Tub Assembly (Rear Half)
K110	3045ER1017A	Drum Assembly
K111	4433ER1005A	Baffle/Roller Assembly
K115	4434ER0001A	Spider (Drive Assembly)
K121	4280FR4048N	Ball Bearing
K122	4280FR4048J	Ball Bearing
K123	4040FR4051C	Main Bolt
K125	4036ER2004A	Main Bearing Seal
K130	4866ER0007A	Balance Weight, Upper
K131	1SZZER4002A	Screw, Custom for Weights (8)
K135	4866ER0004A	Balance Weight, Lower
K140	3551ER0026C	Outer Tub Assembly (Front Half)
K141	4036ER4001B	Gasket
K143	4011FA4353B	Bolt, Standard
K310	6322FR2046F	Thermistor, NTC
K311	4036FR4050A	Gasket
K320	5301FR1158J	Heater Assembly
K340	4681EA2001D	Drain Pump Motor
K342	5214FR4006L	Recirculating Hose
K344	3108ER1001A	Pump Casing
K345	4681EA2001C	Recirculating Pump Motor
K346	383EER2001A	Filter/Cover Assembly
K350	4417FA1994G	Stator Assembly
K351	6501KW2002A	Hall Effect Sensor Assembly
K360	4413EA1002B	Rotor Assembly
K410	4970FR2084P	Tub Support Spring (2)
K411	4930FR3040A	Spring Holder (2)
K510	4986ER0004A	Gasket
K512	4932ER3007A	Dual Nozzle
K510	4986ER0004A	Gasket
K512	4932ER3007A	Nozzle
K520	4738ER1002A	Bellows
K530	4861ER2001D	Clamp Assembly
K540	3504ER3002A	Air Chamber
K550	5214FR4125N	Inlet Hose
K610	383EER3001J	Damper Assembly (3)
K611	4433ER0001A	Damper Pin (3)

Loc #	Part No	Description
-------	---------	-------------

-
- 383EER4001A Gasket Plier (Outer) (SPECIAL TOOL)
 - 383EER4003A Damper Plier (SPECIAL TOOL)
 - 383EER4004A Gasket Plier (Inner) (SPECIAL TOOL)
 - 5214FR3018D DRAIN HOSE EXTENSION (5 FEET)
 - 3W20018B Wrench
-
- 4769ER4001A Mushroom valve, vent
 - 4769ER4002A Mushroom valve, fill

