

MAYTAG

Maytag
Customer Service

Jenn-Air

**Washer
Service Manual**

16007667
Issued 2/97

SAFETY PRECAUTIONS

THIS MANUAL, AS WELL AS THE INFORMATION CONTAINED IN IT, IS TO BE USED ONLY BY A MAYTAG AUTHORIZED SERVICE TECHNICIAN FAMILIAR WITH AND KNOWLEDGEABLE OF PROPER SAFETY AND SERVICING PROCEDURES AND POSSESSING HIGH QUALITY TESTING EQUIPMENT ASSOCIATED WITH MICROWAVE, GAS, AND ELECTRICAL APPLIANCE REPAIR.

ALL INDIVIDUALS WHO ATTEMPT REPAIRS BY IMPROPER MEANS OR ADJUSTMENTS, SUBJECT THEMSELVES AND OTHERS TO THE RISK OF SERIOUS OR FATAL INJURY.

USE ONLY GENUINE MAYTAG APPROVED FACTORY REPLACEMENT COMPONENTS.

INTRODUCTION

The information presented in this manual is printed in a loose format and is divided into sections relating to a general group of components and/or service procedures. Each section is further subdivided to describe a particular component or service procedure.

Anything of a unique nature concerning these models has been detailed and labeled as such in the manual.

The subdividing of the subject matter, plus the loose leaf form will facilitate the updating of the manual as new or revised components are added or new models are introduced.

Each page of the manual will be identified in the lower right-hand corner, and as new or revised pages are published, the manual can easily be updated by following the file instructions on the cover letter of the supplement.

The service manual is a valuable tool and care should be taken to keep it up to date by prompt and proper filing of subsequent pages as they are used.

MODELS COVERED IN THIS MANUAL

JW1000

JW2000

JW3000

CONTENTS

| | |
|---|------------|
| SECTION 1. INSTALLATION | 1-1 |
| PRE-INSTALLATION REQUIREMENT | 1-1 |
| Water Supply Requirements | 1-1 |
| Drain Requirements | 1-1 |
| Electrical Requirements | 1-2 |
| INSTALLATION PROCEDURE | 1-2 |
| | |
| SECTION 2. OUTLINE OF MECHANICAL OPERATION | 2-1 |
| CLUTCH ASSEMBLY | 2-1 |
| AGITATION | 2-2 |
| SPIN | 2-2 |
| | |
| SECTION 3. CABINET ASSEMBLY COMPONENTS | 3-1 |
| CABINET BODY ASSEMBLY | 3-1 |
| Front Panel | 3-1 |
| Rear Access Panel | 3-2 |
| TOP ASSEMBLY | 3-3 |
| DOOR ASSEMBLY | 3-4 |
| CONTROL PANEL ASSEMBLY | 3-4 |
| Disassembly | 3-4 |
| BASE ASSEMBLY | 3-7 |
| STABILIZER ASSEMBLY | 3-8 |
| | |
| SECTION 4. WATER RELATED COMPONENTS | 4-1 |
| WATER MIXING VALVE | 4-2 |
| WATER INLET FLUME | 4-3 |
| AIR BELL | 4-3 |
| HOSES | 4-3 |
| TUB TOP | 4-4 |
| AGITATOR | 4-4 |
| SPIN BASKET | 4-5 |
| OUTER TUB ASSEMBLY | 4-5 |
| PUMP ASSEMBLY | 4-6 |
| | |
| SECTION 5. SUSPENSION SYSTEM | 5-1 |
| SUSPENSION HOUSING | 5-2 |
| TUB BRACES | 5-2 |
| SUSPENSION SPRINGS | 5-2 |
| | |
| SECTION 6. TRANSMISSION AND RELATED COMPONENTS | 6-1 |
| CENTER POST ASSEMBLY | 6-2 |
| BEARING AND SEAL HOUSING | 6-2 |
| TUB SEAL | 6-2 |
| SPIN BEARING | 6-5 |

| | |
|---|-------------|
| DRIVE PULLEY AND CAMS | 6-5 |
| BRAKE ASSEMBLY | 6-9 |
| BASKET DRIVE TUBE AND COVER ASSEMBLY | 6-10 |
| AGITATOR DRIVE SHAFT AND LINKAGE ASSEMBLY | 6-10 |
| CRANK GEAR | 6-11 |
| CLUSTER GEAR | 6-11 |
| CLUTCH ASSEMBLY | 6-11 |
| TRANSMISSION HOUSING ASSEMBLY | 6-14 |
| Oil Seal Replacement | 6-14 |
| LOWER BEARING ASSEMBLY | 6-14 |
| DIAGNOSING TRANSMISSION PROBLEMS | 6-16 |
| Knocking Noise | 6-16 |
| Whining Noise In Agitation..... | 6-16 |
| Oil Leaks | 6-16 |
| Slow Spin Speed | 6-16 |
| OIL REQUIREMENTS | 6-19 |
| | |
| SECTION 7. ELECTRICAL COMPONENTS AND TESTING | 7-1 |
| TIMER | 7-1 |
| TIMER SEQUENCE CHART | 7-2 |
| MOTOR | 7-3 |
| MOTOR SWITCH | 7-3 |
| MOTOR MOUNTING | 7-6 |
| MOTOR CIRCUIT TESTING | 7-7 |
| Overload Protector | 7-7 |
| Motor Switch | 7-8 |
| Motor | 7-8 |
| WATER MIXING VALVE | 7-8 |
| WATER LEVEL SWITCH | 7-9 |
| SELECTOR SWITCHES | 7-11 |
| SAFETY SPIN SWITCH | 7-11 |
| | |
| SECTION 8. SCHEMATIC DIAGRAM | 8-1 |
| | |
| SECTION 9. TROUBLESHOOTING | 9-1 |
| | |
| SECTION 10. ELECTRONIC CONTROL MODEL | 10-1 |
| OPERATING INSTRUCTIONS | 10-1 |
| CYCLE DESCRIPTION | 10-2 |
| CONTROL SHIELD AND ELECTRONIC ASSEMBLY | 10-3 |
| CONTROL PANEL DISASSEMBLY | 10-4 |
| SCHEMATIC DIAGRAM | 10-6 |
| TESTING THE ELECTRONIC CONTROL | 10-9 |
| WATER LEVEL SWITCH | 10-9 |
| WATER LEVEL SWITCH OPERATION | 10-10 |
| TESTING THE WATER LEVEL SWITCH | 10-10 |

SAFETY NOTES

PRECAUTIONS TO BE OBSERVED BEFORE AND DURING SERVICING TO AVOID POSSIBLE EXPOSURE TO EXCESSIVE DANGER AND ELECTRICAL SHOCK:

- 1. Disconnect electrical supply before servicing machine.**
- 2. If electricity is required for a test:**
 - (A) First, disconnect electrical supply;**
 - (B) Second, make any connections or adjustments required for the test;**
 - (C) Third, connect electrical supply;**
 - (D) Fourth, perform the test. If service is required, disconnect electrical supply before servicing machine.**
- 3. Please use caution when servicing the machine with the front panel removed because there is danger of injury due to potential contact with spinning transmission.**
- 4. Please use caution when servicing the machine with the front panel removed because there is danger of injury due to contact with a potential "pinch point" between the turned up edge of the transmission cover and the tub support flange.**

SPECIFICATIONS

| | |
|--|----------|
| WASHER WEIGHT | |
| Shipping - 185 pounds approximately | |
| Operating - 160 pounds approximately | |
| DIMENSIONS | |
| Width | 27" |
| Depth | 27" |
| Height to top of cabinet | 35 3/4" |
| Height to top of control panel | 43 1/16" |
| Height with door open (front to rear opening door) | 53 1/2" |
| FINISH | |
| Cabinet Top - powdered paint | |
| Clothes Door - powdered paint | |
| Outer Tub - constructed entirely of polypropylene | |
| Basket - polypropylene | |
| Cabinet - baked enamel | |
| Base and other finished parts - baked primer | |
| CAPACITY | |
| Up to 22 pounds of clothes (dry weight) | |
| DRAIN HEIGHT | |
| 32 inch minimum | |
| 60 inch minimum | |
| MOTOR | |
| 3/4 H.P., reversible, 115 volt, 60 cycle A.C. | |
| TRANSMISSION | |
| Linkage type, incorporating reduction gears and reciprocating levers | |

| Setting | Gallons | *Depth Inches Perforations | *Basket |
|---------|---------|----------------------------|---------|
| Low | 10.5 | 6" | 3 1/2" |
| Medium | 14.1 | 8 1/2" | 5" |
| High | 19.5 | 11" | 7" |
| Super | 23.3 | 13 1/2" | 9 1/4" |

*Allowable variations are plus or minus 1/2 inch.

AGITATOR SPEED

| | |
|------------------------|------------------------------|
| Regular Cycle | 69.5 Oscillations per minute |
| Slow (Fine Wash) Cycle | 45 Oscillations per minute |

SPIN SPEED

| | |
|------------------------|------------|
| Regular Cycle | 600 R.P.M. |
| Slow (Fine Wash) Cycle | 400 R.P.M. |

| CYCLE | WATER LEVEL | *AMPS |
|------------------|-------------|-------|
| Agitate-Regular | Full Tub | 10.4 |
| Agitate-Slow | Full Tub | 7.6 |
| Agitate-Regular | Dry Tub | 7.5 |
| Spin-Regular | Dry Tub | 10.2 |
| Spin-Slow | Dry Tub | 7.6 |
| Pump Out-Regular | Full Tub | 10.8 |
| Pump Out-Slow | Full Tub | 8.0 |

| COMPONENTS | *RESISTANCE (OHMS) |
|---------------|--------------------|
| Timer Motor | 2360 |
| Mixing Valve | |
| Cold Solenoid | 853 |
| Hot Solenoid | 867 |
| Drive Motor | |
| High Speed | 1.3 |
| Low Speed | 2.3 |
| Start | 3.1 |

* These values can vary slightly.

| CYCLE | *WATTAGE RANGE |
|--------------------------|----------------------|
| Agitate-Regular Full Tub | 610-640 / 670 (MAX.) |
| Agitate-Slow Full Tub | 370-400 / 420 (MAX.) |
| Agitate-Regular Dry Tub | 460-470 / 480 (MAX.) |
| Agitate-Slow Dry Tub | 350-360 / 370 (MAX.) |
| Pump Out-Regular | 760 |
| Pump Out-Slow | 510 |
| Spin-Regular Full Tub | 460 |
| Spin-Slow Full Tub | 340 |

* These will vary with washer load and line voltage.

SPECIAL TOOLS

All special tools are manufactured by Robinaire with the exception of the 35-2442 Brake Removal Tool and 35-2968 Spanner Wrench - Basket Hub. These tools are privately manufactured for and stocked by Maytag Customer Service.

NOTE: The tools listed below can be ordered from any authorized Maytag Customer Service parts distributor.

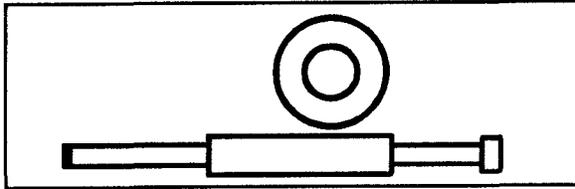

Transmission Seal Tool, Part Number 14242

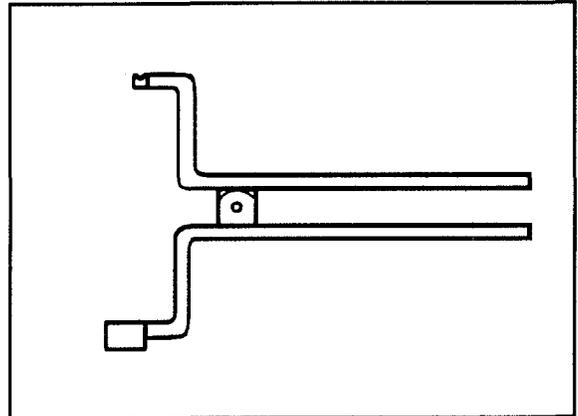

Spring Tool Kit, Part Number 21001138

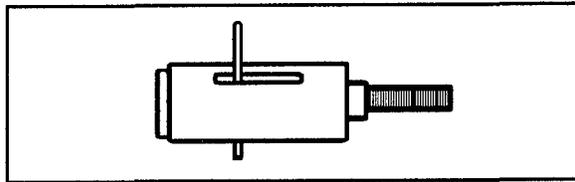

Brake Removal Tool, Part Number 35-2442

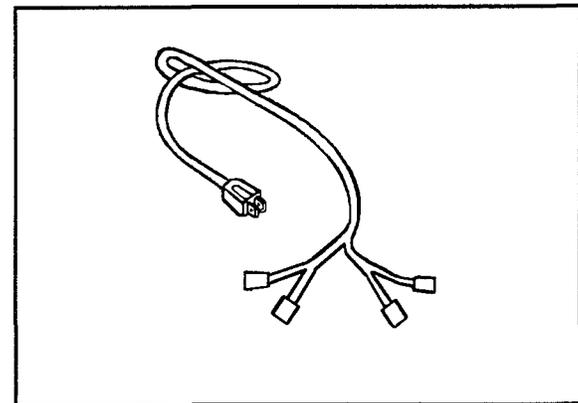

Motor Test Cord, Part Number 038183

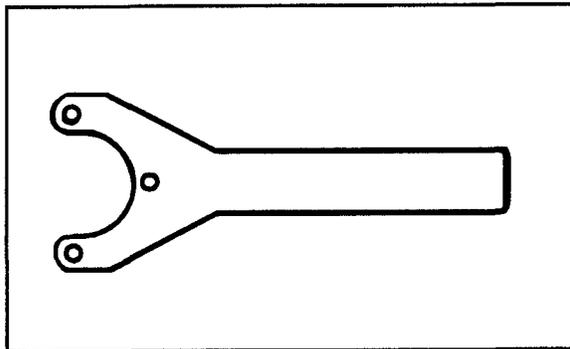

Spanner Wrench-Basket Hub, Part Number 35-2968

SECTION 1. INSTALLATION

PRE-INSTALLATION REQUIREMENTS

PLEASE READ ALL Installation Instructions and requirements before installing.

GENERAL INFORMATION

DO NOT INSTALL THE WASHER ON A CARPETED FLOOR.

DO NOT INSTALL OR STORE THE WASHER WHERE IT WILL BE EXPOSED TO THE WEATHER.

Installation in any location subject to freezing temperatures is not recommended. If the washer must be installed in such a location, it should be thoroughly drained after each use as follows:

- Turn off hot and cold water faucets.
- Disconnect both water inlet hoses at the faucets. Lower them to the floor.
- With the service cord connected to the electrical outlet, rotate the timer to the normal start or fill position and pull timer knob to start washer. Turn water temperature selector switch to warm.
- When water stops draining from the hoses, disconnect service cord.
- Lower the drain hose to the floor and allow it to drain into a floor drain or shallow pan.

In below-freezing temperatures, ice may form in the "fill" flume. Raise the room

temperature and allow time for the ice to melt before using the washer.

Water Supply Requirements

1. Hot and cold water must be available at a pressure between 25 and 125 P.S.I. at the machine.
2. Shut off faucets with standard hose connectors should be available in both hot and cold water lines so that ***the water can always be turned off when the washer is not in use.***
3. The installation should be in accordance with local plumbing code requirements.

Drain Requirements

A drain that will permit 23 gpm flow is required to evacuate the washer. A standpipe at least 32 inches high, but no more than 60 inches high, should be installed at the drain. The standpipe should have a 1 1/2 inch minimum internal diameter to prevent siphoning.

Tight connections between the drain hose and the drain (standpipe, etc.) are not recommended since they violate most local plumbing codes. In cases where a tight connection is required, an anti-siphoning valve, part number **33-4260**, should be placed in the drain hose to prevent siphoning from the washer or facility during agitation.

Electrical Requirements

1. Provide an individual 120 volt, 60 HZ, branch circuit with ground for the washer. This circuit must be rated for 15 amperes or more.
2. Protect the washer's electrical circuit with a 15 ampere time delay fuse or circuit breaker.
3. Install in accordance with National Electrical Code and all local codes and ordinances.

GROUNDING INSTRUCTIONS

The washer must be grounded. In the event of a malfunction or breakdown, grounding will reduce the risk of electrical shock by providing a path of least resistance for electrical current.

The washer is equipped with a power supply cord which has a grounding conductor and three-prong grounding plug. For proper grounding, the three-prong grounding plug must be plugged into an appropriate three-prong grounded receptacle or outlet (see the following figure). The receptacle must be properly installed and grounded in accordance with the National Electrical Code and all local codes and ordinances.

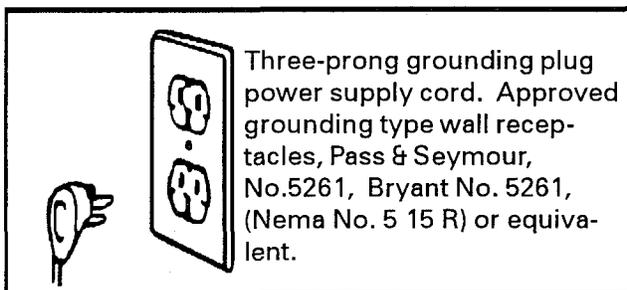

WARNING: *Improper connection of the grounding conductor or the three-prong grounding plug of the power supply cord may result in an electrical shock hazard. If there is any doubt as to whether the washer is properly grounded, have the installation checked by a qualified electrician.*

DO NOT MODIFY THE PLUG PROVIDED WITH THE WASHER - If the plug will not fit the outlet, have a proper outlet installed by a qualified technician.

INSTALLATION PROCEDURE

To remove the carton, cut along the dotted line. Lift the carton and top cap assembly up and clear of the washer.

NOTE: *Retain the corner posts for later use.*

1. Untape and raise the washer lid; remove the items shipped in the spin basket. Save the literature for future reference. Close and tape lid.
2. Place two (2) carton corner posts on the floor to protect the unit and carefully lay the washer on its back on top of the corner posts. **DO NOT LOWER OR RAISE THE WASHER BY THE CONTROL PANEL.**
3. Remove the two hex-head screws holding the wooden shipping base. If the unit has a base made of polypropylene, only one hex-head screw is used.

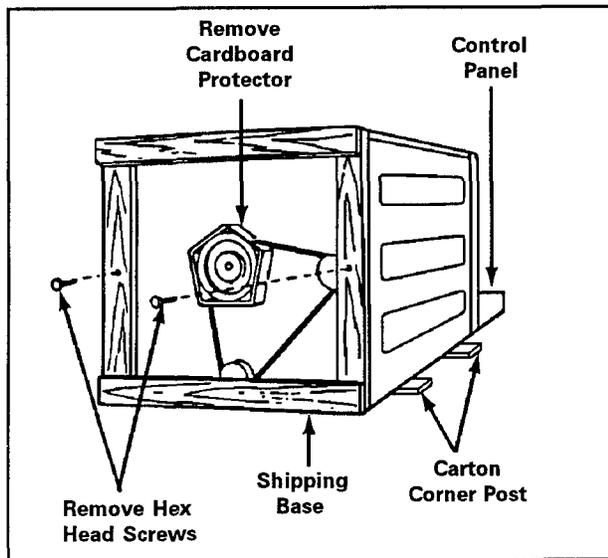

4. Install the drain hose by placing the clamp over the hose (clamp provided in parts envelope). Push the hose onto the pump outlet of the washer. Be sure to position the hose in the direction of the standpipe. Squeeze the clamp ears with pliers, push the clamp up the hose and attach to the pump outlet.

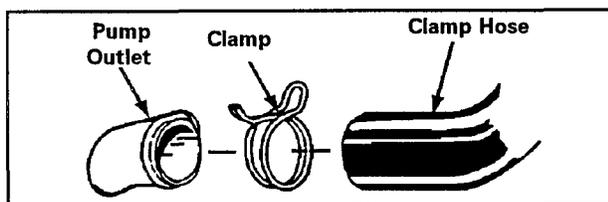
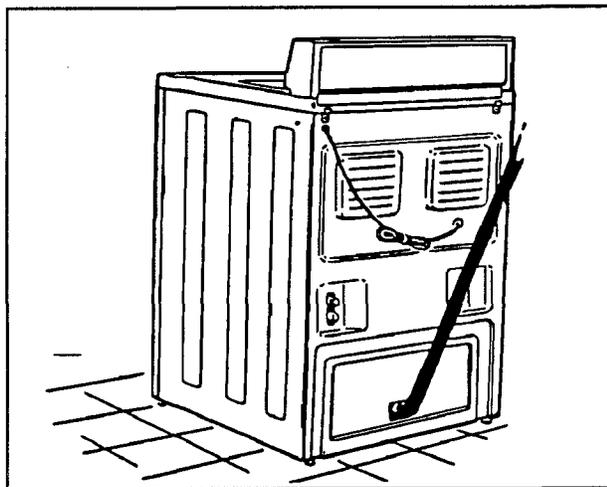

5. Place a flat rubber washer on one end of the water hose, making sure the

washers are pushed in tightly. Attach the hose end with the flat washer to the water mixing valve. Hot and cold connections are identified by H & C stamped in the cabinet. Tighten hose connections by hand until snug. Then, turn another 2/3 of an inch, with pliers.

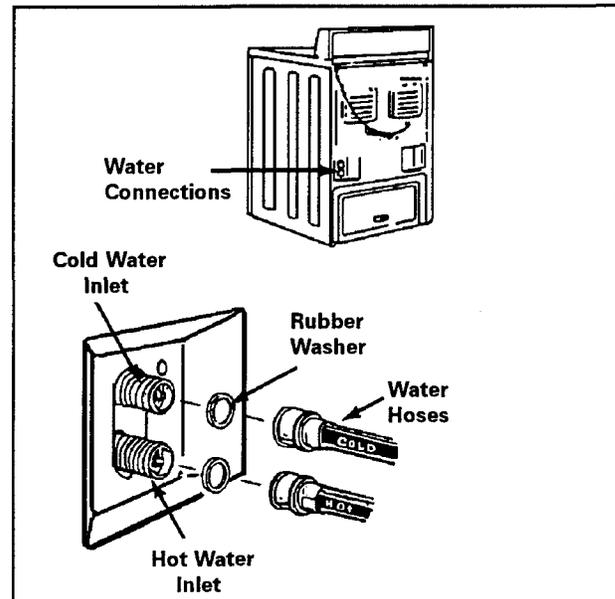

6. Move washing machine to the location where it will be used. A minimum of 1/4" clearance on all sides of the washer is recommended.
7. LEVELING AND/OR STABILIZING THE WASHER

Stabilizer Model

These models are equipped with self-adjusting legs on the rear which will automatically stabilize the unit.

The front legs are threaded and can be adjusted up and down to level the unit.

Proceed as follows:

- Place the washer as close to its final operating location as possible.
- Make sure rear feet move up and down freely.

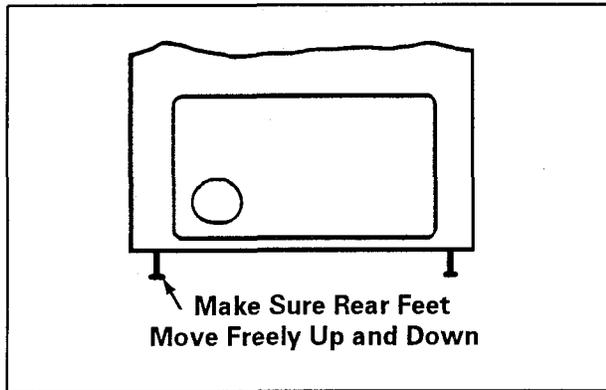

- Place washer in final location.

Front foot adjustment for side to side leveling - Loosen the locknut, making sure it turns freely on the threads.

- When the machine is in place, screw front feet out of base against the floor until the machine is acceptably level across the front.
- While holding foot still, turn the adjusting locknut clockwise until the nut is tightened firmly against base.

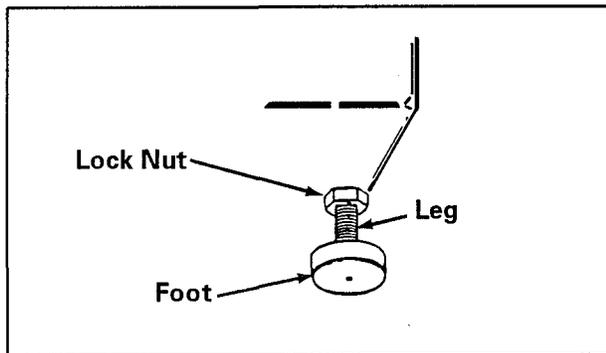

Tilt machine forward until rear of cabinet is approximately 4 inches off the floor, then lower the machine back to the floor on the rear feet. This operation will cause the rear stabilizing feet to conform to the contour of the floor and seat them solidly. Rock washer with hands on opposite corners to check stability.

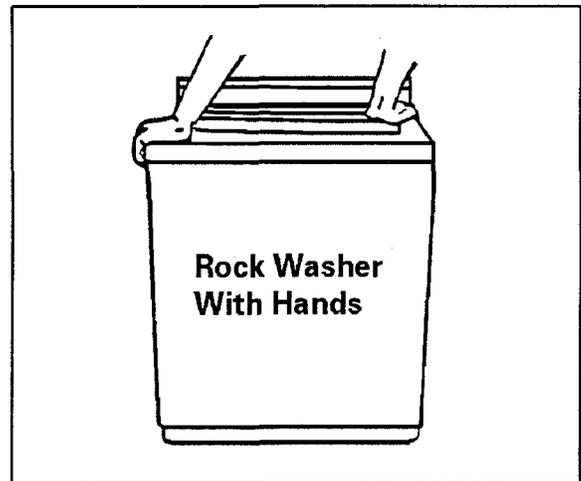

8. Place the gooseneck end of the drain hose into the standpipe or laundry tub. The drain hose should fit loosely in the standpipe to prevent siphoning. (An anti-siphon valve and associated parts are available from your dealer, part number 33-4260).

NOTE: BE SURE THE DRAIN HOSE IS NOT TWISTED OR KINKED.

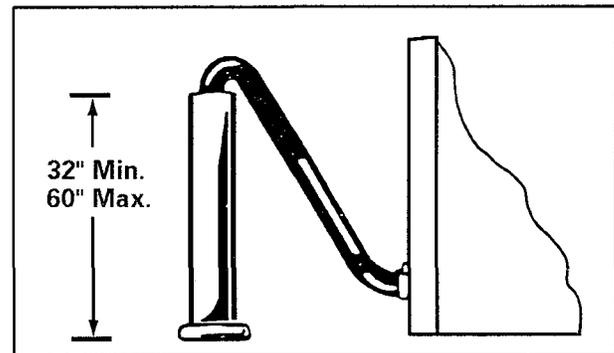

9. Insert the screens and washers (provided in the parts envelope) into the remaining ends of the water hoses. Attach the water hoses to the hot and cold faucets. **BE SURE HOT WATER INLET IS CONNECTED TO HOT WATER FAUCET.** Tighten by hand until snug, and then a 2/3 turn with pliers.

DO NOT OVER TIGHTEN. Turn on Faucets and check for leaks. Tighten to stop leaks if necessary.

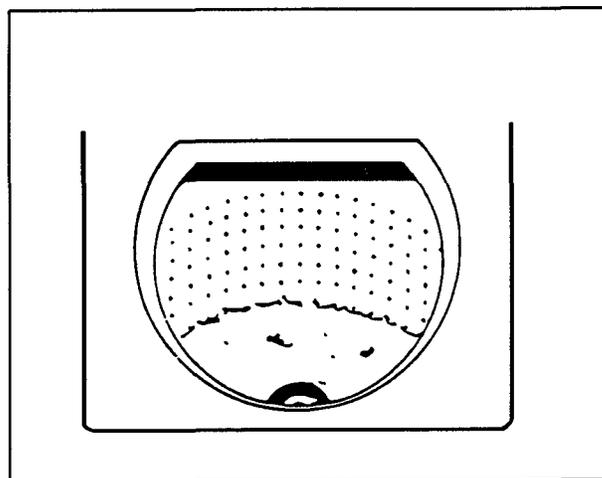
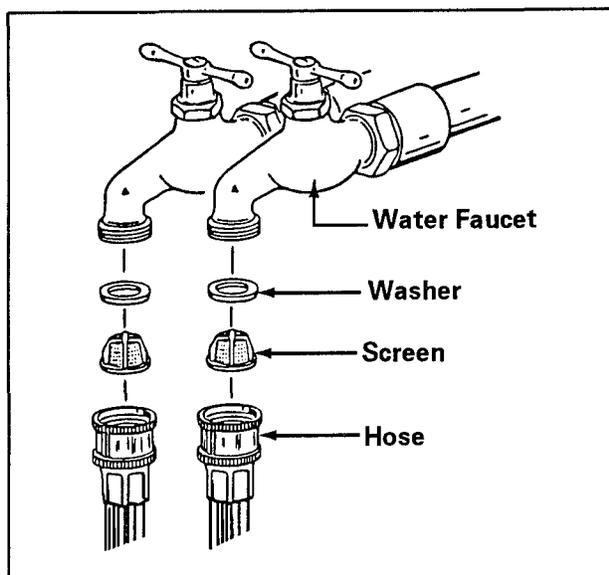

If the water is not level with the bottom row of holes all around the basket, readjust the leveling feet as required to level. Then remove the water by selecting a spin cycle.

10. Plug the power cord into an outlet.
11. Start the washer in a spin cycle, per operating instructions, to center basket.
12. Start the washer in a wash cycle, as per operating instructions. Allow water to fill in machine until it reaches the level of the bottom row of holes in the wash basket. Then, stop the washer by pushing on timer knob.

FINAL CHECK OUT

1. Have all installation requirements been observed?
2. Have locknuts on front feet been tightened?
3. Are there any kinks in the hoses?
4. Are any water leaks evident?

SECTION 2. OUTLINE OF MECHANICAL OPERATION

GENERAL INFORMATION

The washer utilizes a reversible type motor which runs clockwise during the agitate cycle and counterclockwise during the spin cycle.

Note: The rotation directions as stated in this outline, are when viewing the component from its pulley end.

A single belt is used to transmit power from the motor pulley to the drive pulley and pump pulley.

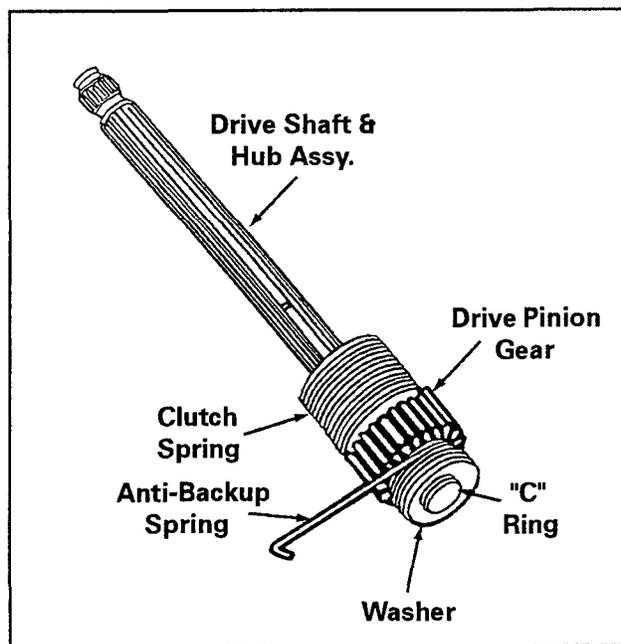

The drive pulley which drives the transmission drive shaft and hub assembly, and the pump pulley and hub assembly, and the pump pulley which drives the pump impeller, are in operation whenever the motor is running.

The transmission assembly converts the power from the motor to either drive the agitator or spin the basket. The direction the clutch assembly rotates determines which action takes place.

CLUTCH ASSEMBLY

The clutch assembly consists of the drive shaft and hub assembly, clutch spring, drive pinion, and the anti-backup spring. The anti-backup spring, also the clutch type spring, is mounted on the smaller machined hub of the drive pinion and secured with a flat washer and retaining ring. One end of the clutch spring fits

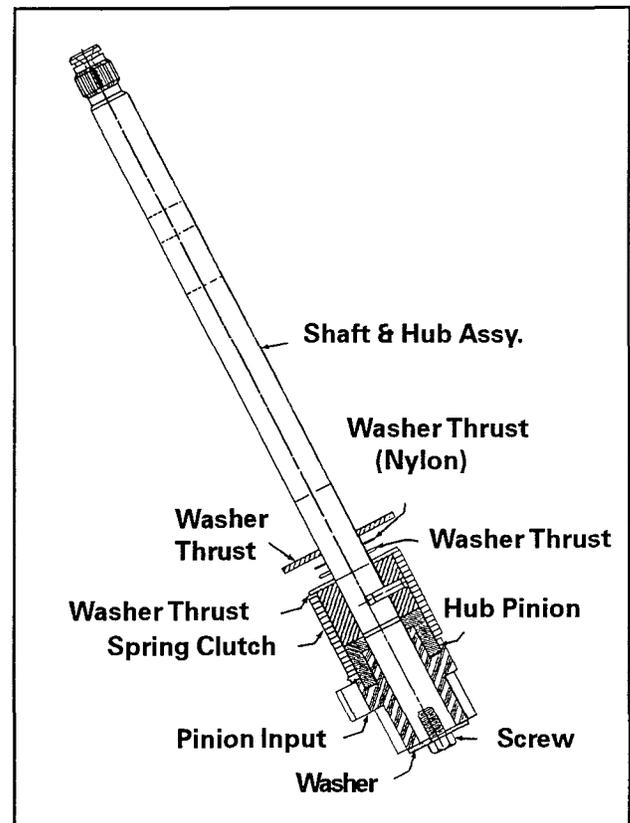

over the drive hub which is pinned to the drive shaft, and the other end fits over the larger machined hub of the drive pinion. The drive shaft serves only as a bearing surface for the drive pinion to revolve on, and no direct drive is imparted from the shaft directly to the pinion.

The inside diameter of the clutch spring is so designed that when the drive shaft

hub is driven in a clockwise direction, the clutch spring tightens on the two hubs and becomes a positive drive link between them. When the drive shaft hub runs counterclockwise, the clutch spring relaxes in an override situation. In the override, or relaxed position the clutch spring still maintains a drive link between the two hubs. The override tension, or torque is used to drive the spin basket.

The anti-backup spring is a clutch type spring, one end which terminates in an extended leg and hook configuration. The coil portion of the spring is mounted over the drive pinion hub as previously described, and the extended leg portion is fitted with its hooked end secured in a slotted boss in the transmission housing.

When the drive pinion rotates in a clockwise direction, the spring relaxes and exerts no appreciable force on the drive pinion. When the drive pinion starts to revolve counterclockwise, the spring tightens on the hub of the pinion and prevents it from turning.

Note: Later models use an anti-backup cam stop under the crank gear, instead of the anti-backup spring.

CLUTCH ASSEMBLY - DUAL DRIVE

The clutch assembly consists of the drive shaft and hub assembly, clutch spring, and input pinion with gear lock assembly. The gear lock mechanism is part of the input pinion. The drive shaft serves only as a bearing surface for the drive pinion to revolve on. **No direct drive is imparted from the shaft directly to the pinion.** The inside diameter of the clutch spring is designed so that when the drive shaft is driven in a clockwise direction, the clutch spring tightens on the two hubs and be-

comes a positive link between them. When the drive shaft hub runs counterclockwise, the clutch spring relaxes in an override situation. In the override, or relaxed position, the clutch spring still maintains a drive link between the two hubs. The override tension, or torque, is used to drive the spin basket. The gear lock mechanism consists of two "wings" that project out from the input pinion. When the drive pinion rotates in a clockwise direction, the gear lock mechanism exerts no force on the input pinion. When the input pinion starts to revolve counterclockwise, the "wings" drop into detents in the lower housing preventing the pinion from turning.

AGITATION

The clockwise (agitate) rotation of the drive shaft and the hub assembly is transmitted to the drive pinion by the clutch spring. The drive pinion meshes with the cluster gear which, in turn, meshes with the crank gear. The circular motion of the crank gear is converted to the oscillating action of the agitator shaft by a linkage arrangement which consists of a connecting rod that mounts over a stud on the crank gear, and a lever assembly. Any tendency of the transmission housing to turn or "creep" is prevented by the engaged brake assembly located on the under side of the suspension housing.

AGITATION - DUAL DRIVE

The clockwise (agitate) rotation of the drive shaft and hub assembly is transmitted to the input pinion by the clutch spring. The input pinion meshes with the dual cluster gears which, in turn, mesh with the dual crank gears. The circular motion of the dual crank gears is con-

verted into the oscillating action of the agitator shaft by the dual rack gears. The rack gears have a stud that drops into the crank gears. These rack gears are contained by a rack carrier. Any tendency of the transmission to turn, or "creep", is prevented by the engaged brake assembly located on the underside of the suspension housing.

SPIN

Two nylon cams, located just below the special drive pulley, provide a cam action which raises the drive pulley during the counterclockwise (spin) rotation of the motor. As the drive pulley hub moves up, it compresses a brake spring and lifts the brake rotor and lining assembly, disengaging it from the stator. The transmission is now free to spin.

The counterclockwise rotation of the drive shaft and hub assembly causes the clutch spring to relax into its override position. As previously stated, the clutch spring still exerts a driving force to the drive pinion even when it is in the override position.

As this driving force of torque starts to turn the drive pinion in a counterclockwise direction it causes:

- a. the anti-backup spring to tighten on the drive pinion hub (earlier models) or
- b. the crank gear to back up until the cam, formed on the crank gear lower hub, engages a mating notch formed on the anti-backup cam stop (later models).

Both designs are used to prevent the drive pinion from revolving in the counterclockwise direction. Therefore, the torque being delivered by the clutch spring is

exerted against the transmission housing, causing the entire assembly to rotate.

The washer basket is mounted to the basket drive hub which is secured to the transmission cover assembly, and revolves as part of the transmission. The counterweight serves to balance out the weight of the gears when the transmission is spinning.

In this direction, the pump assembly will drain the water from the machine.

SPIN - DUAL DRIVE

A nylon cam along with a special drive pulley provide a cam action which raised the drive pulley during the counterclockwise (spin) rotation of the motor. As the drive pulley hub moves up, it compresses a brake spring and lifts the brake rotor and lining assembly, disengaging it from the stator. The transmission is free to spin. The counterclockwise rotation of the drive shaft and hub assembly causes the clutch spring to relax into its override position. As previously stated, the clutch spring still exerts a driving force to the input pinion even when it is in the override position. As this driving force of torque starts to turn the input pinion in a counterclockwise direction it causes the "wings" of the gear lock mechanism to drop into detents on the lower housing. This prevents the input pinion from revolving in the counterclockwise direction. Therefore, the torque being delivered by the clutch spring is exerted against the transmission housing causing the entire assembly to rotate. The washer basket is mounted to the basket drive hub which is secured to the transmission cover assembly, and revolves as part of the transmission. In this direction, the pump assembly will drain the water out of the unit.

SECTION 3. CABINET ASSEMBLY COMPONENTS

The components that comprise the cabinet assembly of the washer consists of: the cabinet body assembly, front panel, rear access panel, top assembly, base assembly, and the stabilizer assembly.

CABINET BODY ASSEMBLY

The cabinet body assembly consists of a steel enameled "U"-shaped cabinet with a reinforcement brace welded across the upper front of the assembly.

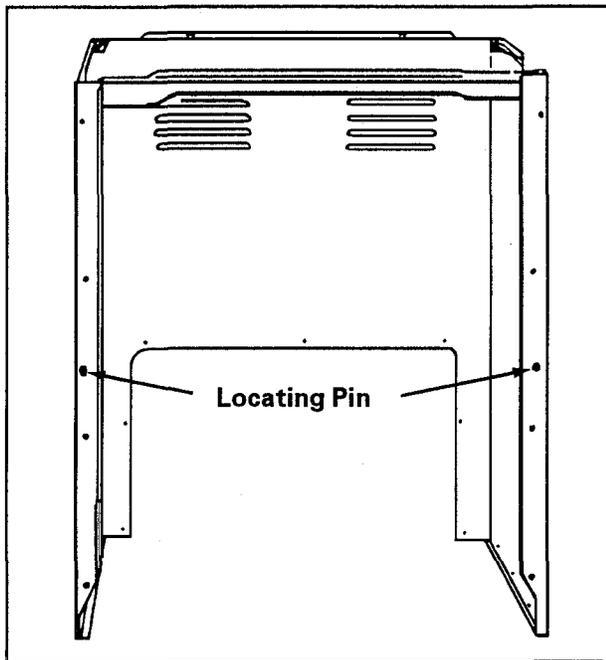

The cabinet body assembly provides mounting for the front panel, rear access panel, top assembly, water mixing valve, and the power cord.

The cabinet body assembly is attached to the perimeter of the base with ten (10) screws.

REMOVAL:

1. Disconnect the unit from the power source.
2. Remove the top assembly as detailed later in this section.
3. Remove the front panel as detailed later in this section.
4. Remove the top hinges and power cord.
5. Remove inlet hoses from water mixing valve.
6. Remove rear access panel.
7. Remove water mixing valve.
8. Remove wiring clips and clamps from inner cabinet rear.
9. Remove the screws that secure the cabinet body to the perimeter of the base.
10. Open the front of the cabinet body slightly and push it off the rear of the base.

Front Panel

The enameled steel front panel is attached to the cabinet body brace at the top, and secured at the bottom with base mounting clips. Locating pins on the cabinet front flanges position the front panel for assembly (*see illustration on the following page*).

The front panel provides mounting for the locating pins and top clips.

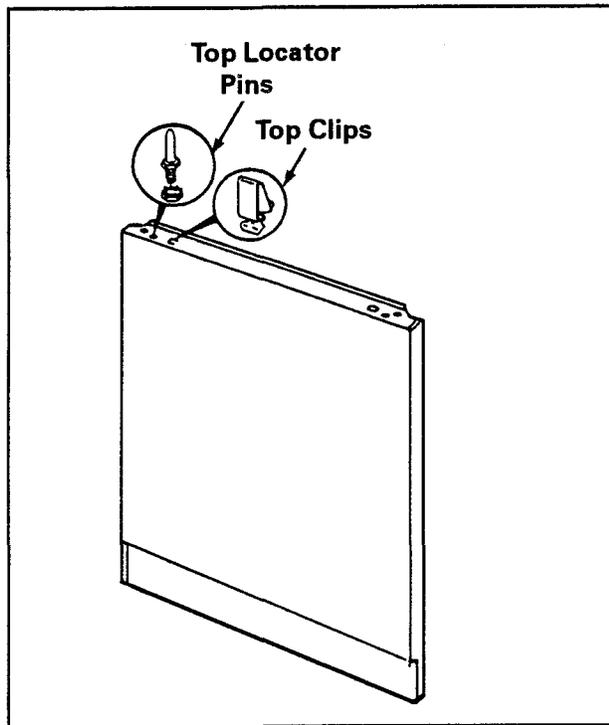

Front panel removal will allow access to the:

- Motor
- Motor Mount
- Motor Wiring
- Motor Pivot Spring
- Front Suspension Spring
- Tub Brace

Removal:

1. Disconnect the unit from the power source.
2. Insert a thin bladed tool between the front panel and the top assembly, approximately four (4) inches in from each corner. While lifting up on the top assembly, press the blade against the wire clips, one side at a time to disengage them.

3. After raising the top assembly, remove the two (2) screws which attach the front panel to the cabinet brace.
4. Tip front panel back to clear the locating pins on the cabinet front flanges. Lift the panel up and off the two (2) base mounting clips.

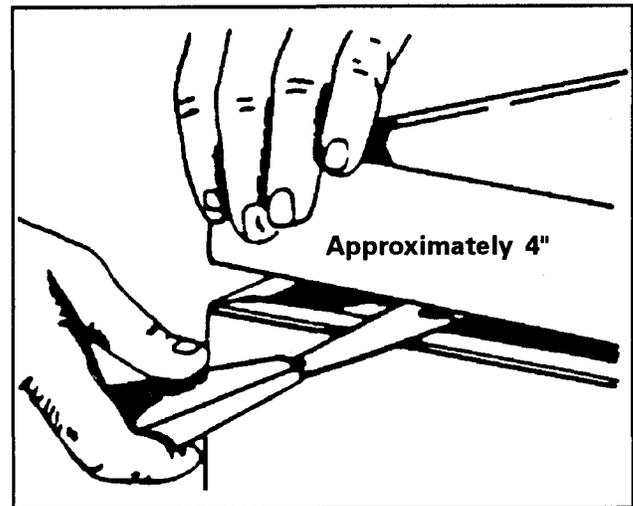

Rear Access Panel

The access panel is constructed of enameled steel and is attached to the cabinet rear by eight (8) hex head screws.

Panel removal will allow access to the:

- Stabilizer Assembly
- Water Mixing Valve
- Pump Assembly
- Rear and Side Suspension Springs
- Tub Braces
- "J" Bolts

TOP ASSEMBLY

The top assembly consists of the top panel, clothes door assembly, safety spin switch and bracket, water inlet flume, insulating grommet, bleach dispenser (some models), and the control panel assembly.

The assembly is mounted to the cabinet with two (2) steel hinges which are attached to the upper cabinet rear by two (2) screws. These hinges fit into slots located in the back edge of the top panel which allows the top assembly to be raised for servicing.

Two (2) holes pierced into the front flange of the top assembly align with two (2) locating pins to center the top assembly to the cabinet. Two (2) spring clips engage the top panel flange and secure the top assembly to the cabinet front.

NOTE: *The locating pins and top clips are mounted to the front panel flange on all the models. (See the following figure).*

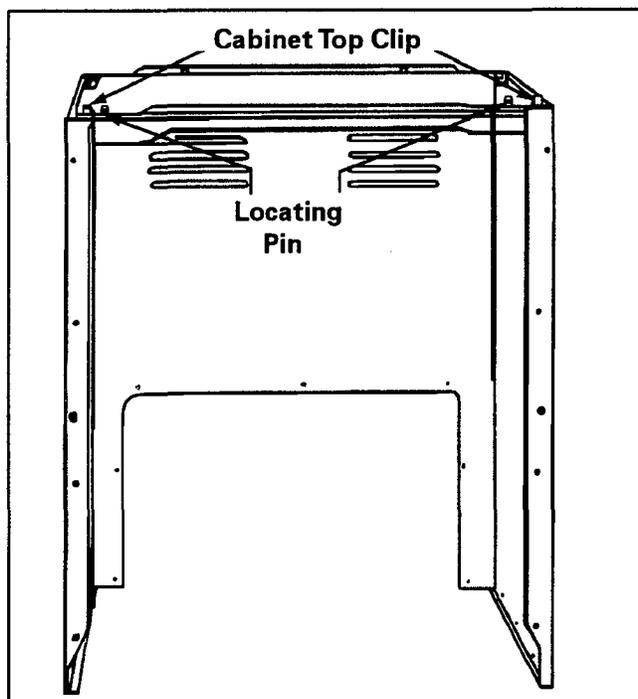

Raising the top will allow access to:

- Door Hinge Mounting Screws
- Flume and Inlet Hose
- Safety Spin Switch
- Air Bell Hose Connection
- Control Panel Mounting Screws
- Power Cord/Harness Connection
- Water Inlet Valve Wiring
- Pressure Switch Hose Clamp
- Agitator
- Basket Assembly

To raise the top assembly, insert a thin bladed tool (such as a putty knife) between the front panel and top assembly approximately four (4) inches in from each corner. Depress each spring clip while raising the top assembly.

REMOVAL:

1. Disconnect the unit from the power source.
2. Raise the top assembly and remove the flume inlet hose.
3. Lower top and remove the control panel rear shield.
4. Disconnect the pressure switch hose and all necessary wiring. Feed the hose and wiring through their respective top holes.
5. Raise the top assembly slightly while pulling forward to remove.

DOOR ASSEMBLY

The door assembly consists of the door panel, mounting hinges, plastic strike (switch actuator) and cushioning bumpers. The assembly is secured to the top panel by the two (2) mounting hinges.

When the door assembly is closed, the plastic strike (actuator) protrudes through a slot in the top panel and depresses a lever that actuates the safety spin switch.

CONTROL PANEL ASSEMBLY

IMPORTANT

The model/serial plate is located on top of the control panel assembly. When replacing the control panel be sure to transfer the model/serial plate information to the new part.

A typical control panel assembly as shown by the *illustration on page 3-6*, consists of these components: The control panel, knobs, end caps, clips, control shield, control panel shield, timer, switches and hood.

The control panel assembly is secured to the top by screws which pass upward through the top panel and thread into the end cap clips. The assembly is further retained and supported at the rear by the control panel shield which is attached to the control panel, end caps and top flange.

The control panel is attached to the end caps at the bottom front and top rear

corners. The control shield, which provides the mounting for all controls, is also attached to the end caps.

Disassembly

Before attempting to gain access to the controls mounted within the control panel assembly, place a protective cloth or pad on the cabinet top in front of the control panel to prevent scratches.

1. Disconnect the unit from the power source.
2. Remove the timer and selector knobs, as follows:
 - The timer knob threads onto the timer shaft and is removed by turning it in a counterclockwise direction.
 - Remove the selector knobs by pulling straight off.
3. Remove the three (3) screws which secure the rear top edge of the control panel to the end caps and control panel shield.
4. Remove the two (2) screws which secure the bottom front corners of the control panel to the end caps.
5. Disconnect indicator lights, if so equipped, and lift off the control panel.
6. Remove the screws which secure the control shield to the end caps, and lay the front of the shield on the protective cloth. The control panel components are now accessible for testing and/or replacement.

7. The twist mount switches require no screws to attach them to the control shield. Instead, the tabs formed on the face of the switch are inserted into specially formed cutouts in the control shield, then the rear of the switch is rotated clockwise. This allows a spring tab, located on the switch, to interlock into a mating

cut-out in the control shield and secures the switch to the shield.

Switch removal is accomplished by disengaging the switch locking tab from the control shield cut-out, and rotating the rear of the switch in a counterclockwise direction.

CONTROL PANEL JW2000A & JW2000W

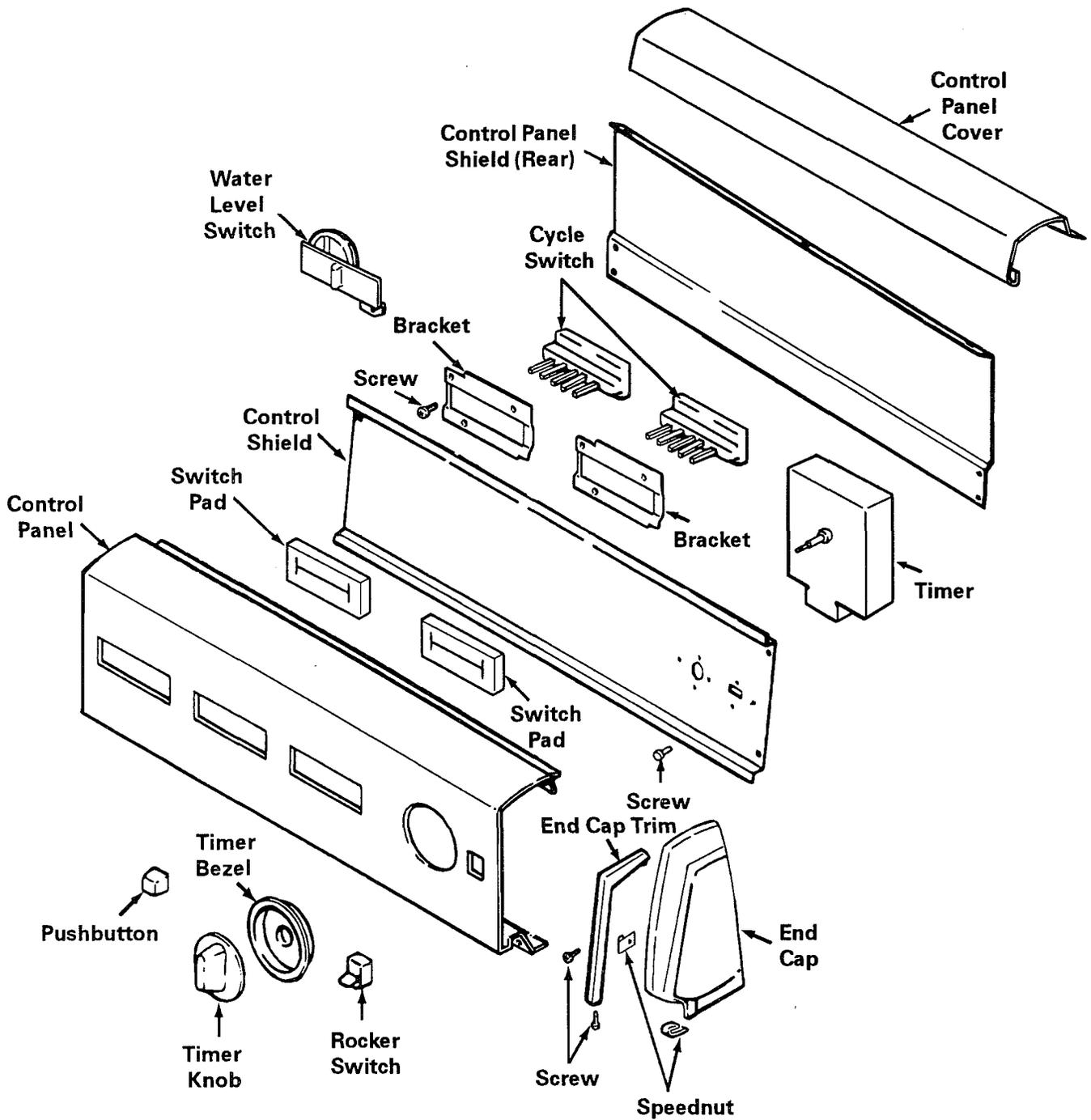

BASE ASSEMBLY

The base assembly, which serves as a support for the entire wash unit, is constructed of heavy gauge metal that has been flanged and embossed for strength.

A suspension housing with a spherical configuration is assembled to the lower portion of the wash unit. This suspension housing rides on the raised dome-like

snubber area in the center of the base. The mounting is similar to a ball joint and allows the housing to move freely in all directions.

The base assembly also provides mounting for the pump assembly, motor and plate assembly, suspension springs, front panel clips, and the stabilizer assembly.

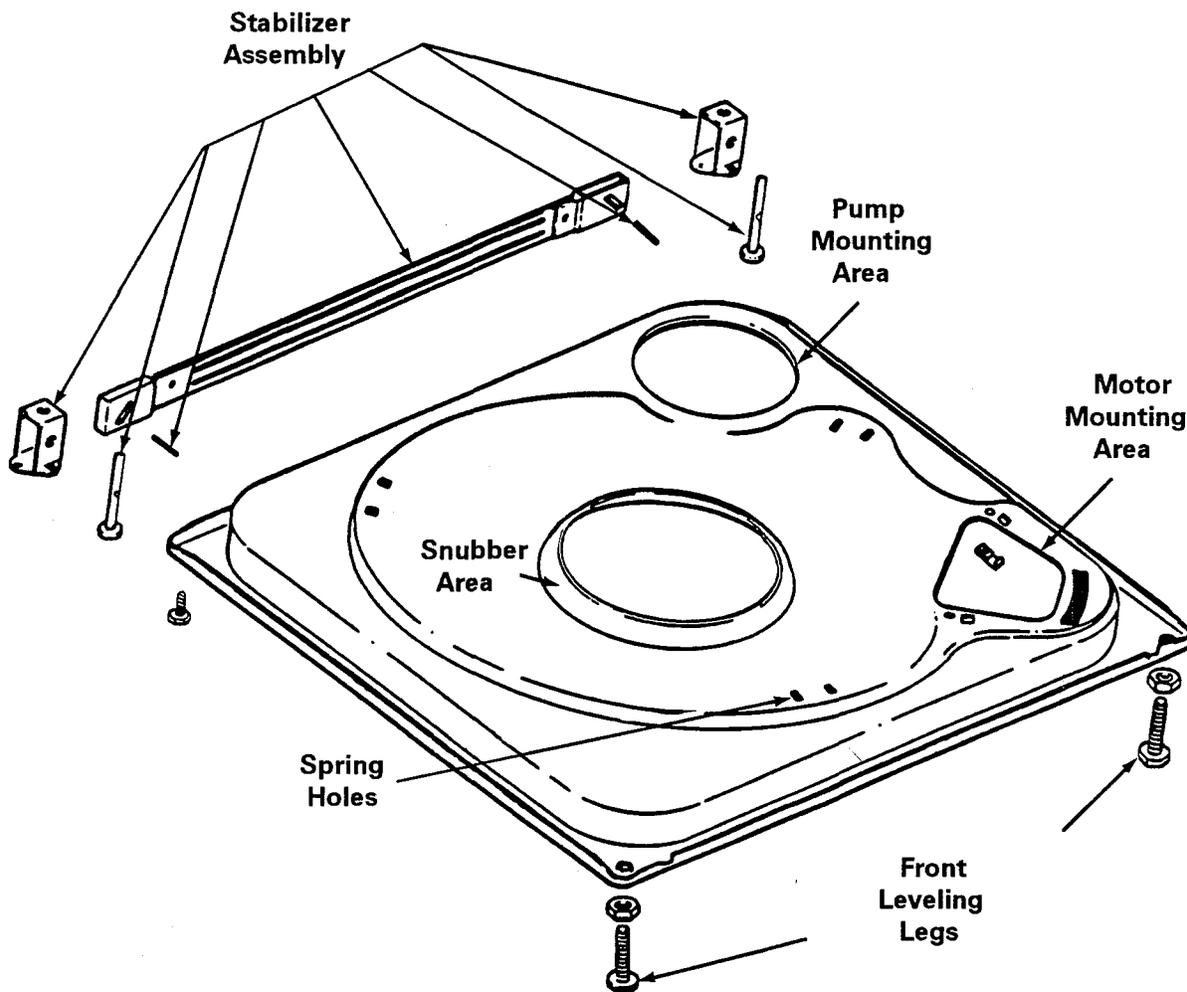

The cabinet is secured to the base by cushioned screws to prevent vibration or noise transfer. The cabinet does not support any of the wash unit's weight.

BASE REPLACEMENT:

1. Disconnect the unit from the power source.
2. Tip unit and remove the drive belt.
3. Disconnect the inlet hoses from the water mixing valve.
4. Remove the access panel from the cabinet rear and disconnect the discharge hose from the pump outlet.
5. Remove the top assembly.
6. Remove the front panel.
7. Disconnect lower wiring from the cabinet rear (water mixing valve, power cord, etc.) and remove pressure switch hose from tub air bell.
8. Remove the screws attaching the cabinet to the base.
9. Push the front of the cabinet slightly and push or pull it off the rear of the base.
10. Disconnect the pump hose from the tub outlet and remove the pump assembly and hose from the base.
11. Remove motor mounting screws, ground wire and wiring clips from base. Lift the motor and plate assembly from the base with the wiring harness attached.
12. Remove the suspension springs and lift the complete wash unit from the base.
13. Remove the stabilizer assembly from the base assembly, as detailed later in this section.
14. Transfer the remaining hardware from the defective base to the replacement.
15. Installation is a reversal of the above procedure.

STABILIZER ASSEMBLY

The stabilizer assembly consists of the stabilizer bar assembly, two (2) stabilizer brackets, two (2) self stabilizing feet, and two (2) foot pins. It is mounted on the top rear of the base assembly.

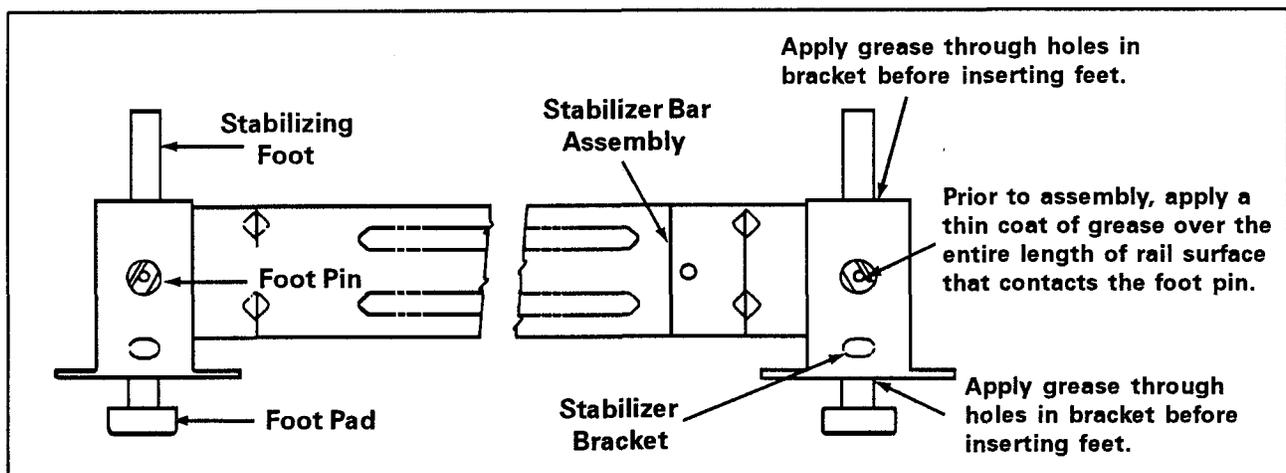

The stabilizer assembly allows the base assembly to rest solidly and firmly against the floor, even if the floor is unlevel. The solidity of the base to the floor keeps the washer from rocking back and forth or "walking" during operation.

As the name implies, the stabilizer only stabilizes the unit; it does not level it. Any leveling that is required must be done with the front adjusting (leveling) legs.

In rare cases where the floor is so uneven that it is beyond the stabilizing limit of the assembly (+ or - 5/8"), it may be necessary to remove the stabilizer assembly and install two (2) rear adjustable feet. Two (2) threaded holes have been provided in the rear corners of the base for this situation.

Removing the Stabilizer Assembly:

1. Disconnect the unit from the power source.
2. Remove the access panel from the cabinet rear.
3. Tip or lay washer down and remove the screws from the underside of the base that attaches the stabilizer assembly to the base.
4. Remove the stabilizer assembly through the rear access panel.
5. To disassemble the stabilizer assembly after removal, drive the two (2) foot pins out of the feet and brackets.

NOTE: *In order for the stabilizer assembly to operate properly, a thin coating of grease must be applied over the entire length of the four (4) pin guides as well as the foot holes in the bracket. (See the stabilizing assembly figure on page 3-8.)*

SECTION 4. WATER RELATED COMPONENTS

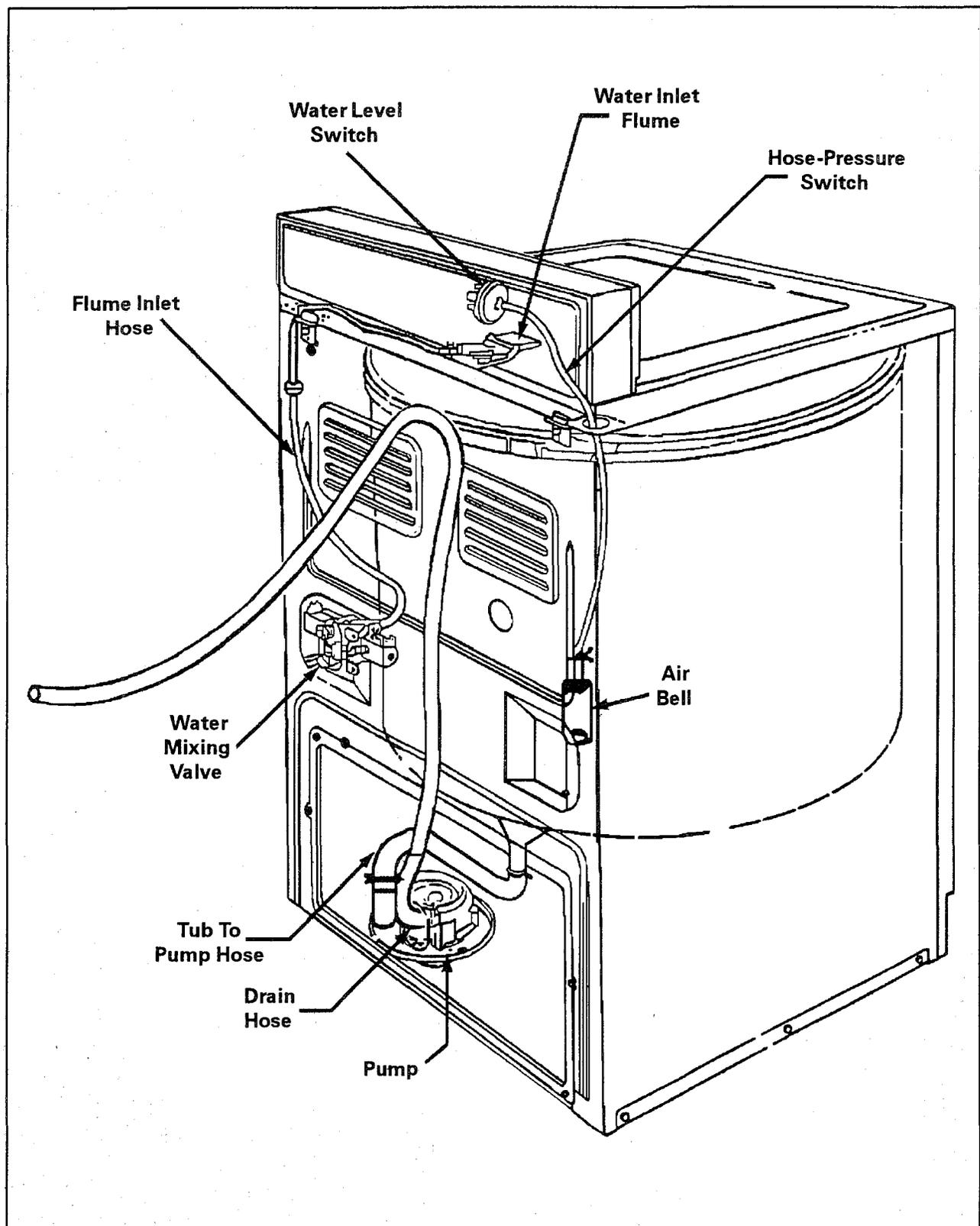

WATER MIXING VALVE

The water mixing valve is located inside the right rear cabinet. It is secured by two (2) screws inserted through the cabinet into the valve bracket. The hot and cold water supply inlet hoses are attached to the nozzles of the water mixing valve.

The mixing valve will allow hot or cold water, or a mixture of the two as

called for by the control circuitry, to enter the machine through the inlet hose and inlet flume.

Usually, the temperature of the warm water entering the machine will be about halfway between the cold and hot water temperatures delivered to the mixing valve. This is provided the pressure and flow rate of both are equal.

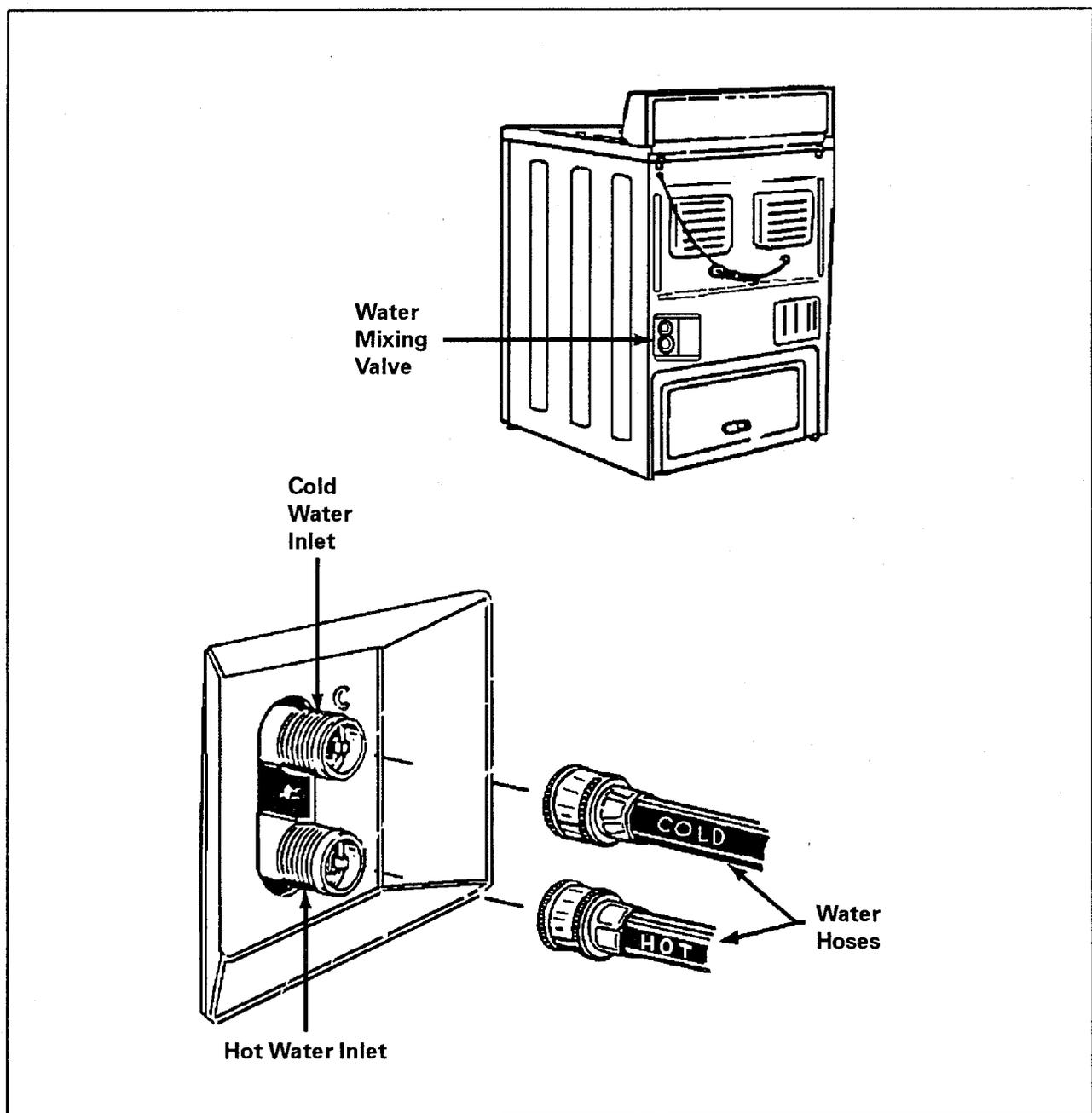

WATER INLET FLUME

The molded plastic water inlet flume consists of an upper and lower section that have been snap-locked together. This forms a water tight assembly with a built-in siphon break.

The flume is located on the rear underside of the washer top assembly. The flume fits flush with the top opening and is secured to the top by two (2) mounting screws. An inlet hose from the water mixing valve connects to the flume nozzle.

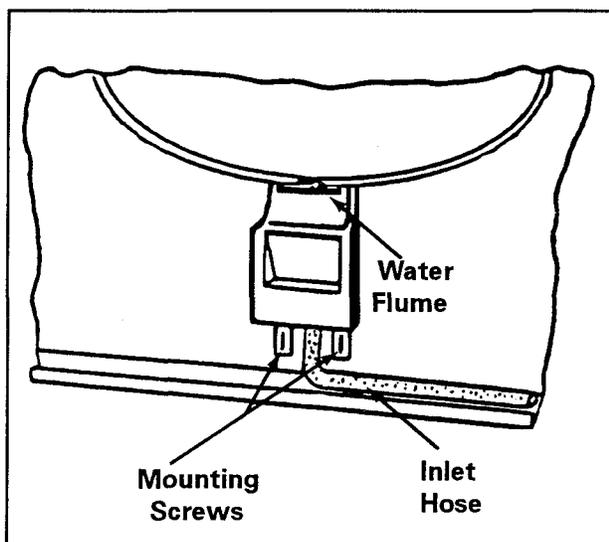

AIR BELL

A polypropylene air bell and nipple assembly has been thermally welded to the lower, outer tub, rear. One end of the pressure switch hose connects to the air bell nipple and the other end is attached to the water level switch.

As the water level rises in the tub, it compresses the air in the air bell nipple and the attached hose. The compressed air inside the hose will activate the pneumatically operated water level switch when the selected water level has been reached. The lack of compressed

air will also reset the switch during the drain cycle.

NOTE: *When reinstalling the pressure switch hose, make sure the system is free of air leaks and water in the hose, or an overflow condition will occur.*

HOSES

Water Supply Inlet Hoses

Two (2) water inlet hoses attach from hot and cold water supply lines to their respective nozzles on the water mixing valve and are secured at both ends with threaded couplings.

Flume Inlet Hose

The flume inlet hose attaches the water mixing valve to the water inlet flume. It is secured at both ends with spring type hose clamps.

Pressure Switch Hose

The pressure switch hose is made of soft plastic tubing and fits snugly over the water level switch nipple at one end, and the air bell nipple at the other. A clamp on the inner cabinet rear positions the hose, and a pad prevents the hose from contacting the back of the cabinet during operation. The hose is installed with its ends butted against the switch and air bell bodies, and is secured at both ends with a spring type hose clamp.

Tub to Pump Hose

The tub to pump hose attaches from the drain nipple on the tub to the pump inlet nozzle. It is secured at each end with a spring type-hose clamp.

Drain Hose

The drain hose attaches the pump outlet to the drain standpipe. It is secured to the pump with a spring-type hose clamp.

TUB TOP

The tub top is constructed of molded polypropylene. It is secured to the tub by eight (8) tabs which have been formed around its periphery. These tabs snap over mating tab locks which are molded around the upper sides of the tub.

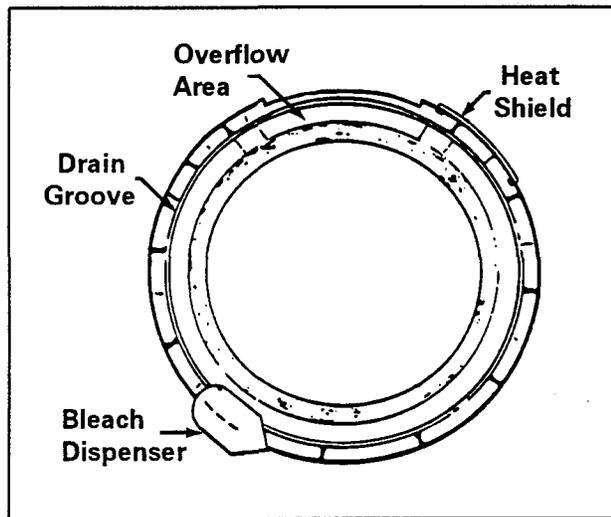

Designed into the tub top is a drain groove, an overflow area, and a bleach dispenser. In case water should splash out of the basket during machine operation, the **drain groove** directs the water back into the tub. The **overflow** area is located at the tub top rear and will direct any overflow water away from the drive motor. The **bleach dispenser** is functional only when used in conjunction with the proper cabinet top assembly which is available on designated models.

A foam seal has been installed in a groove on the underside of the tub top.

The seal provides a water seal between the tub and the tub top.

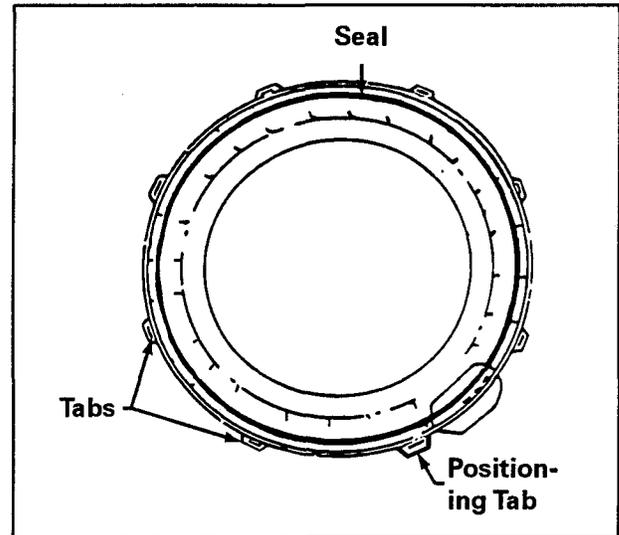

It is necessary to remove the tub top before removing the spin basket. To remove the tub top, push down on it while disengaging the tabs from the tab locks on the tub.

NOTE: When reinstalling the tub top, please observe the following:

1. Make sure the foam seal is in place on the underside of the tub top.
2. Align the tab on the tub top having the larger opening with its mating tab lock on the tub, and lock it down around the tub. This seals the top.

AGITATOR

The agitator is a four vane design molded from a polypropylene compound. It is tough flexible material, highly resistant to breakage. The agitator is mounted on the splined top of the agitator shaft and secured with the agitator retaining screw and washer. A plastic agitator cap snaps over the top of the agitator.

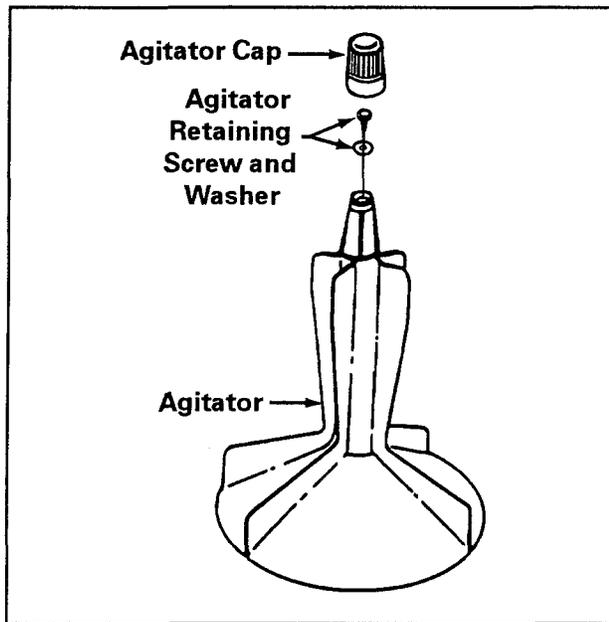

SPIN BASKET

The spin basket is perforated in a pattern designed to allow free flow of the wash and rinse water for maximum efficiency in removing sediment, soil deposits, and lint.

The spin baskets are constructed entirely of polypropylene and are secured to the basket hub assembly with four (4) mounting screws.

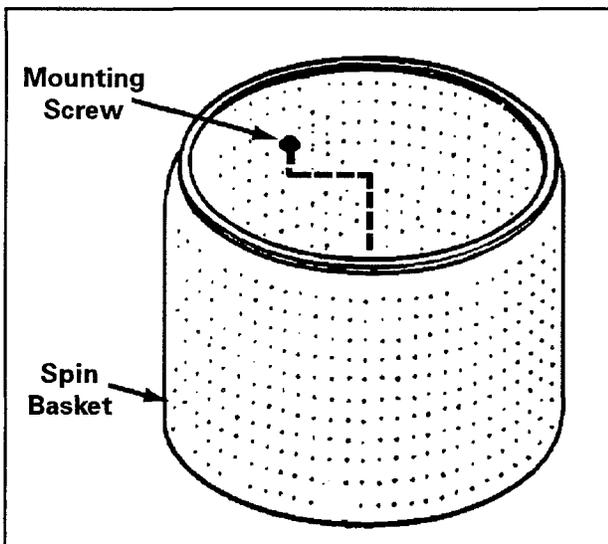

A foam gasket is installed between the basket and the basket hub assembly.

REMOVAL:

1. Disconnect the unit from the power source.
2. Raise the top assembly and lean it back.
3. Remove the tub top.
4. Remove the agitator.
5. Remove the mounting screws.
6. Lift the spin basket up over the center post and out of the cabinet.

NOTE: *When reinstalling the spin basket, be sure to:*

- Clean all connecting surfaces to assure proper sealing.
- Position the basket on the basket hub assembly.
- Align the assembly and tighten all screws securely.

OUTER TUB ASSEMBLY

The outer tub assembly is molded entirely of polypropylene and consists of the tub, top locks, air bell, and drain nipple.

The tub assembly is mounted to the bearing and seal housing and to the tub support. A foam gasket and a rubber seal are installed between the tub bottom and the bearing and seal housing.

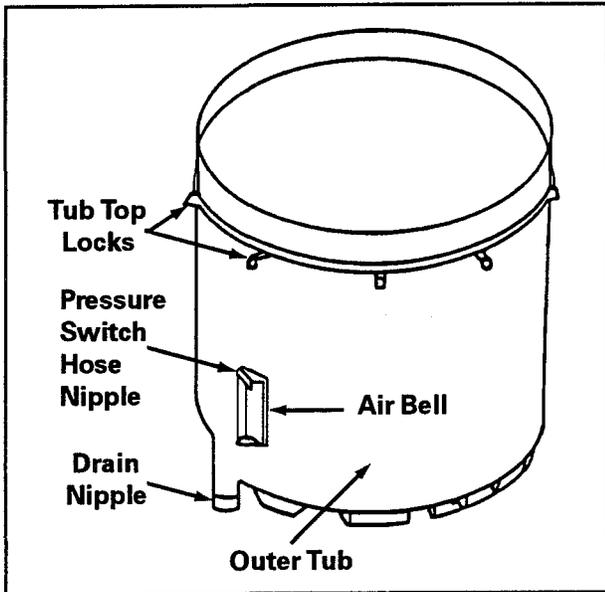

NOTE: When reinstalling the tub assembly, be sure to:

- **Protect the air bell nipple.**
- Clean all connecting surfaces to assure proper sealing.
- Position the gasket and seal on the bearing and seal housing.
- Tighten all screws securely.

REMOVAL:

1. Disconnect the unit from the power source.
2. Remove the spin basket.
3. Remove the front panel.
4. Remove the rear access panel.
5. Disconnect the pump inlet hose from the tub drain nipple.

NOTE: The nipple is somewhat fragile.

7. Remove the screws located on each side of the tub brace bolts which secure the tub to the tub support.
8. Remove the mounting screws on the inside of the tub which mount the tub to the bearing and seal housing.
9. **PROTECT THE AIR BELL NIPPLE** and lift the tub from the cabinet.

PUMP ASSEMBLY

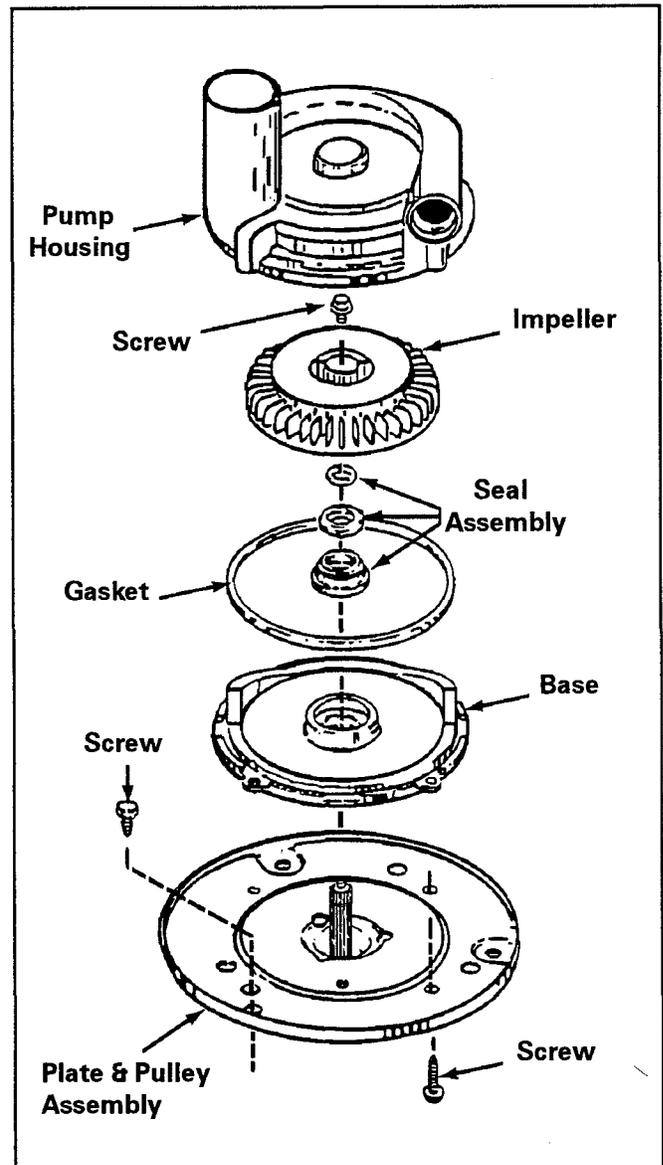

The pump assembly is located on the right rear corner of the washer base.

The pump pulley is engaged to the drive belt at all times and will be operating in both motor directions: Clockwise during agitation and counterclockwise during spin. However, the pump is designed so it will only discharge water from the machine when it is running in the counterclockwise, or spin direction.

REMOVAL:

1. Disconnect the unit from the power source.
2. Remove the drain hose from the pump outlet.
3. Remove the rear access panel from the cabinet rear.
4. Disconnect the pump inlet hose.
5. Remove the three (3) screws which mount the pump assembly to the base.

6. Slide the pump forward to disengage the belt from the pulley.

NOTE: *If this is done carefully, the belt will remain on the motor and transmission drive pulley, making installation easier.*

REINSTALLING:

Place one hand through the pump opening and lift belt. Set the pump pulley into the opening and place the belt on the pulley. While holding tension on the belt to keep it on the pulleys, install the mounting screws.

DISASSEMBLY:

1. Remove the pump from the washer base.
2. Remove the four (4) screws that secure the housing to the pump base, and lift off the housing.
3. Remove the screw that secures the impeller.
4. Using two (2) screwdrivers, one on each side of the impeller, carefully pry the impeller off the spline shaft.
5. Work the seal mating ring and "O" ring up and off the shaft.

SECTION 5. SUSPENSION SYSTEM

The washer utilizes a six (6) point suspension system which consists of the suspension housing, snubber pad, tub braces, suspension springs and related hardware.

The six (6) point system features six (6) lighter duty springs. Three (3) springs are installed between the base and the top of the tub brace. The other three (3) are between the base and special spring hooks attached to the tub support perimeter.

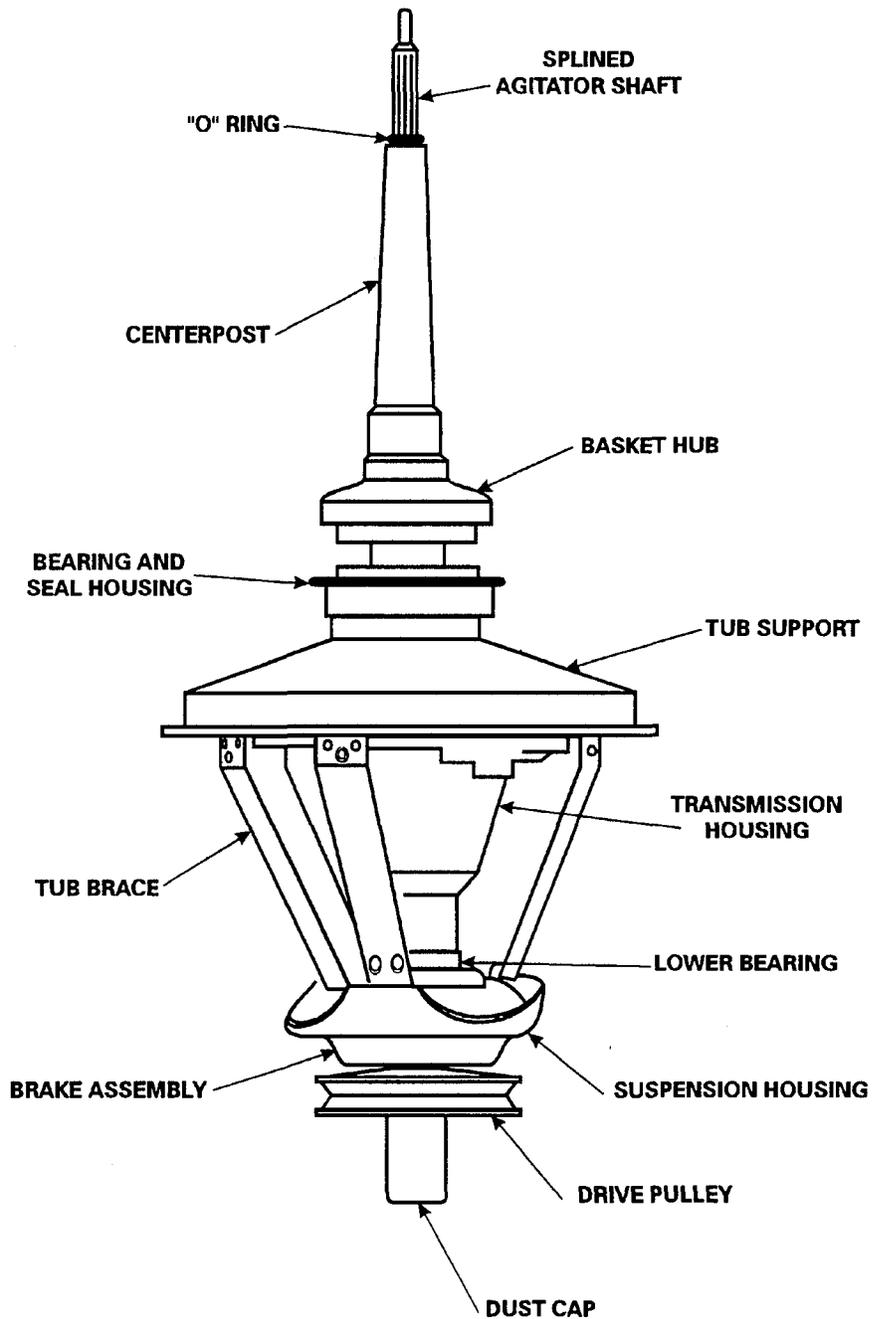

SUSPENSION HOUSING

The suspension housing is fabricated of heavy gauge steel. It rests on the raised dome-like area in the center of the transmission, outer tub, and spin basket.

The underside of the suspension housing provides mounting for the snubber pad and also houses the brake assembly.

The bottom of the housing has been formed into a spherical configuration and, along with the snubber, rides on the domed area of the base which allows the housing to move freely in all directions.

The top of the suspension housing is attached to the lower bearing assembly with three (3) mounting screws. These screws thread from the underside of the suspension housing dome into the die-cast bearing housing.

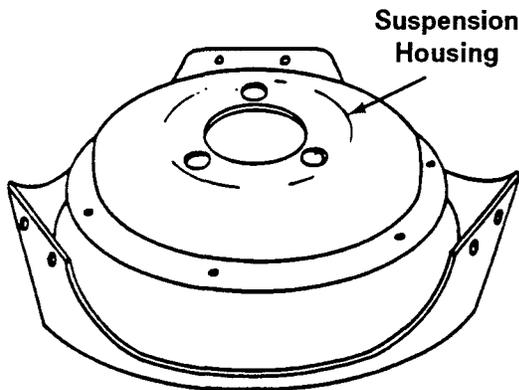

Service to the suspension housing, other than replacing it, is limited to replacing one of the other components that mount to the housing. The replacement procedures for these components are detailed in the **Transmission Section** of this manual.

REMOVAL:

1. Disconnect the unit from the power source.

2. Remove the transmission assembly as detailed in **Section 6**.
3. Remove the brake assembly as detailed in **Section 6**.
4. Remove screws securing housing to the lower bearing assembly.

TUB BRACES

The tub braces are attached at the top to the tub support, and to the suspension housing at the bottom. The tub braces are located **behind** the tub support and suspension housing where large, thread forming screws are driven directly into the braces to secure them.

NOTE: *Should a tub brace mounting screw hole become stripped, a nut can be installed on the thread forming screw.*

The extended end of the suspension spring fits through an extruded hole in the tub brace just below the mounting screws.

SUSPENSION SPRINGS

The suspension springs hold the entire wash unit in firm contact with the base. To reduce wear and prevent squeaks; grease has been applied to the friction points of the springs.

REMOVAL:

The suspension springs can be removed and replaced by using the spring tool, part number **21001138**, as follows:

1. Disconnect the unit from the power source.

SECTION 5. SUSPENSION SYSTEM

The washer utilizes a six (6) point suspension system which consists of the suspension housing, snubber pad, tub braces, suspension springs and related hardware.

The six (6) point system features six (6) lighter duty springs. Three (3) springs are installed between the base and the top of the tub brace. The other three (3) are between the base and special spring hooks attached to the tub support perimeter.

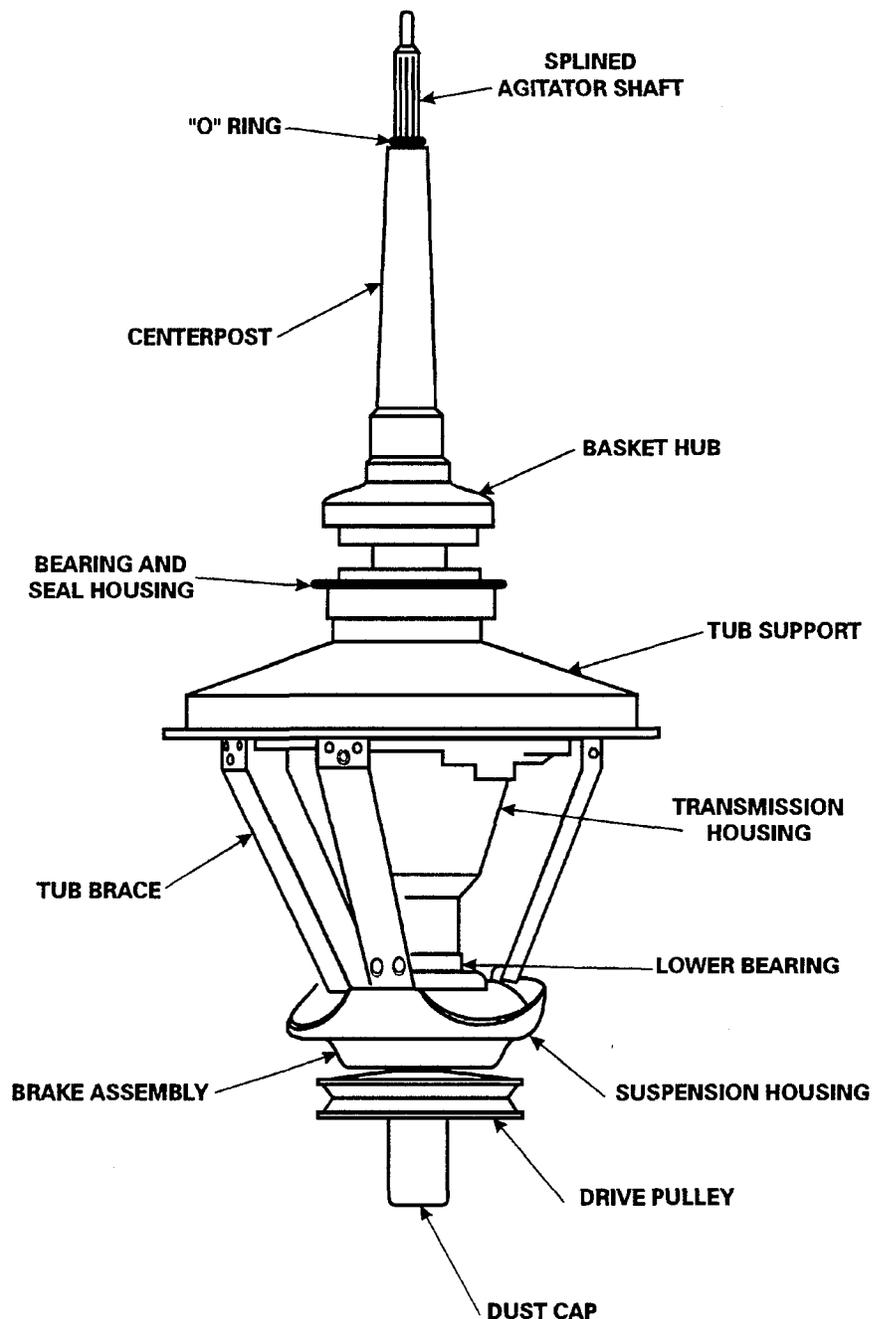

SUSPENSION HOUSING

The suspension housing is fabricated of heavy gauge steel. It rests on the raised dome-like area in the center of the transmission, outer tub, and spin basket.

The underside of the suspension housing provides mounting for the snubber pad and also houses the brake assembly.

The bottom of the housing has been formed into a spherical configuration and, along with the snubber, rides on the domed area of the base which allows the housing to move freely in all directions.

The top of the suspension housing is attached to the lower bearing assembly with three (3) mounting screws. These screws thread from the underside of the suspension housing dome into the die-cast bearing housing.

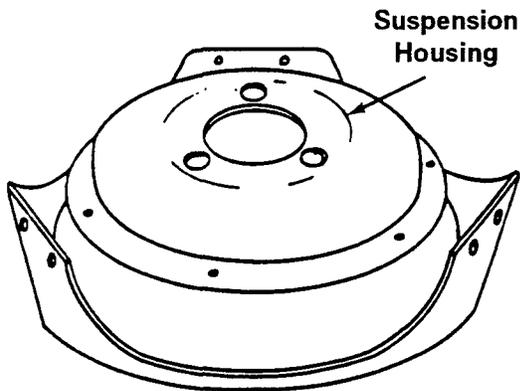

Service to the suspension housing, other than replacing it, is limited to replacing one of the other components that mount to the housing. The replacement procedures for these components are detailed in the *Transmission Section* of this manual.

REMOVAL:

1. Disconnect the unit from the power source.

2. Remove the transmission assembly as detailed in *Section 6*.
3. Remove the brake assembly as detailed in *Section 6*.
4. Remove screws securing housing to the lower bearing assembly.

TUB BRACES

The tub braces are attached at the top to the tub support, and to the suspension housing at the bottom. The tub braces are located *behind* the tub support and suspension housing where large, thread forming screws are driven directly into the braces to secure them.

NOTE: *Should a tub brace mounting screw hole become stripped, a nut can be installed on the thread forming screw.*

The extended end of the suspension spring fits through an extruded hole in the tub brace just below the mounting screws.

SUSPENSION SPRINGS

The suspension springs hold the entire wash unit in firm contact with the base. To reduce wear and prevent squeaks; grease has been applied to the friction points of the springs.

REMOVAL:

The suspension springs can be removed and replaced by using the spring tool, part number **21001138**, as follows:

1. Disconnect the unit from the power source.

2. Remove the front panel and rear access panel.
3. Pull or block the tub in the direction of the spring to be removed. Place the round end of the tool against the base of the unit and extend the spring.

NOTE: *Removing the tub top will allow the tub to travel further and extend the spring even more.*

4. Spring replacement is a reversal of the above.

NOTE: *Be sure to grease the friction points of the replacement springs before installing.*

IMPORTANT

No attempt should be made to remove or install the springs with pliers, vise-grips or anything other than the spring tool, as damage to the springs will probably occur. When attaching the springs to the base for installation, make sure the spring end is protruding up through the small triangular cut out next to the deboss.

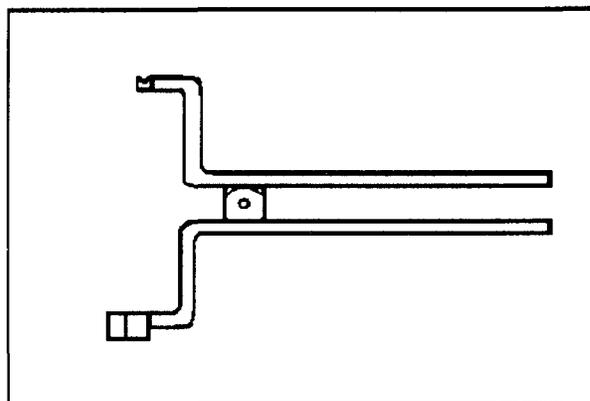

**SPRING TOOL KIT
PART NUMBER 21001138**

SECTION 6. TRANSMISSION AND RELATED COMPONENTS

This section will detail the servicing procedures on the transmission linkage assembly which has splines formed on the agitator drive shaft. An "O" ring is installed on the shaft just above the center post to provide a center post seal when the agitator is installed.

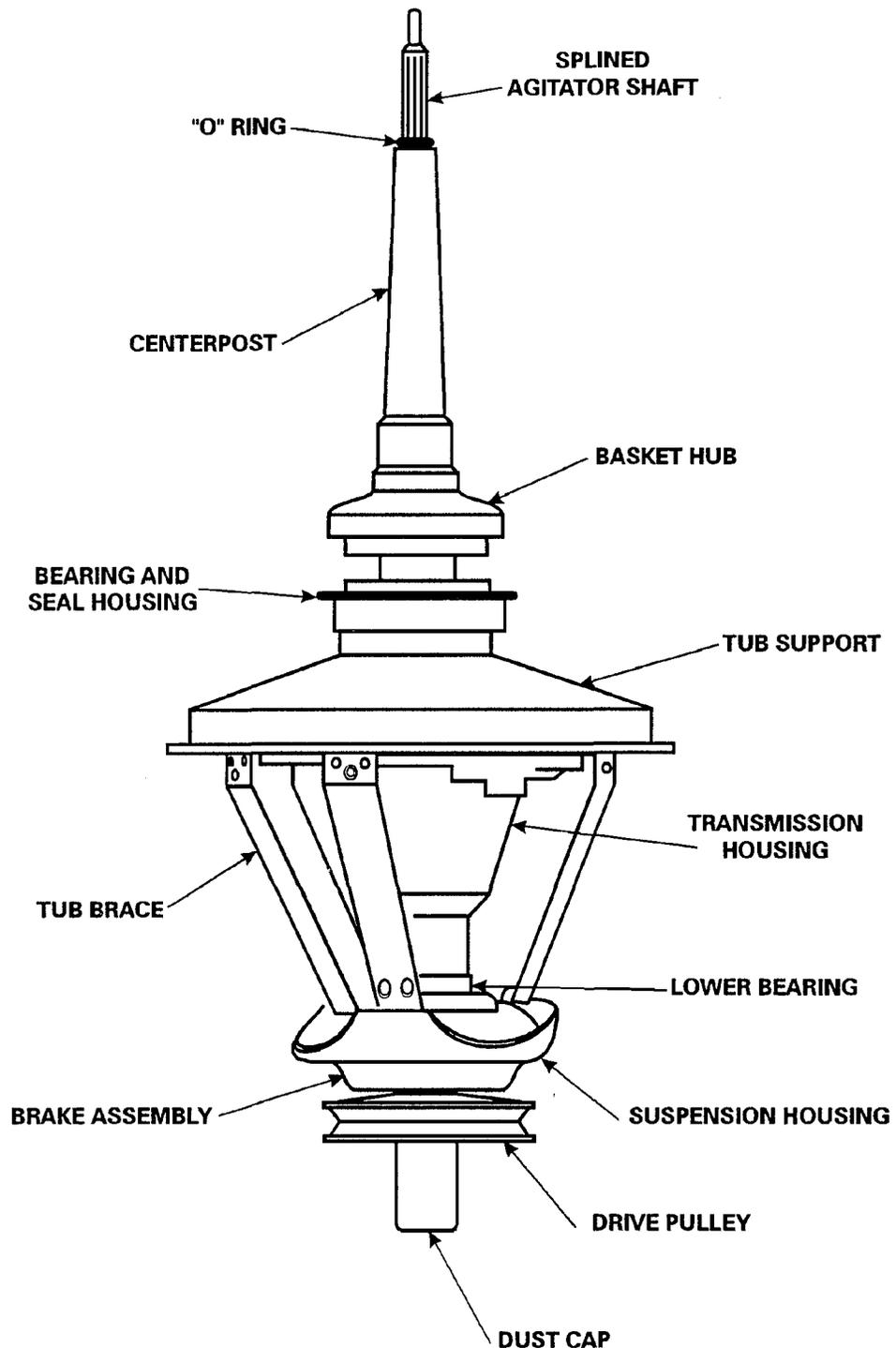

CENTER POST ASSEMBLY

The center post assembly consists of a plastic center post with a bearing installed in its top inside diameter. A nylon agitator bearing slips over the lower portion on the center post body.

The center post assembly is secured to the basket hub assembly by the spin basket, and to the agitator shaft by the drive block (earlier models). A small rubber gasket is installed in a groove on the bottom of the spin basket and the basket hub assembly.

The center post can be removed after removing the spin basket and drive block (earlier models) or agitator shaft "O" ring (later models).

CENTER POST - DUAL DRIVE

The center post on the Dual Drive units do not require an upper bearing. The cover and tub assembly has two bearings installed to hold the agitator in place. A nylon agitator bearing slips over the lower portion of the center post body. The center post assembly is secured to the basket hub assembly by the spin basket. A small rubber gasket is installed in a groove on the bottom flange of the center post, and a foam gasket is assembled between the bottom of the spin basket and the basket assembly. The center post can be removed after removing the spin basket and agitator shaft "O" ring.

BEARING AND SEAL HOUSING

The die cast bearing and seal housing slips over a machined area on the lower drive tube. The basket hub assembly

threads down over the drive tube and secures the bearing and seal housing.

The spin bearing and the tub seal are installed in a cavity in the center of the housing. The sheet metal tub support is attached to the under side of the housing with three (3) mounting screws.

NOTE: *On earlier models, the spin bearing has been pressed into the top of the housing cavity and is secured by a large retaining ring. A brass slinger is installed just above the spin bearing and the seal body locates over both.*

On later models, the spin has been pressed into the underside of the housing cavity and is captured by the tub support. Therefore the retaining ring and slinger used previously have been removed. The seal body is unchanged and locates as before.

The center of the tub assembly mounts to the upper flange of the housing with a tub gasket and a tub seal installed in between. The bottom of the tub sits on, and is attached to the tub support.

REMOVAL:

1. Disconnect the unit from the power source.
2. Remove the agitator, spin basket, tub assembly, drive block (earlier models), and center post.
3. Remove the "C" ring and washer located on the drive shaft just above the end of the drive tube.
4. Remove the locking nut as follows:
 - a. Loosen the set screw (if present) in the locking nut.

NOTE: *The set screw has been removed on later models.*

- b. On earlier models, use tool number 14917 and unscrew in a counterclockwise direction.
- c. On later models, use a small pipe wrench and turn the lock nut in a counterclockwise direction.

IMPORTANT

Whenever a locking nut with a set screw is removed, a small triangular file or thread chaser (Tool No. 14922) should be used to restore the drive tube threads which were damaged by the set screw. Be sure to wipe the filings away from the threads to prevent them from binding the basket hub assembly as it is removed.

- 5. Remove the basket hub assembly by unscrewing it in a counterclockwise direction. Use Tool No. 14916, 14917, on earlier models and Tool No. 35-2968 on later models.
- 6. Remove the suspension springs to prevent damage to the tub braces and unbolt the tub braces from the tub support.
- 7. To remove, lift up on the bearing and seal housing with tub support attached.
- 8. To disassemble tub support from housing, remove mounting screws from underside.

TUB SEAL

The tub seal consists of the seal face, the seal body, and on earlier models, the slinger.

NOTE: *All parts of the seal must be replaced if either of the sealing surfaces is damaged.*

Earlier Models: The seal face fits into a recess in the underside of the basket hub assembly. The seal slinger is installed in the bearing and seal housing, on top of the spin bearing, with its coned or narrow end down. The seal body is also installed in the housing cavity on top of the spin bearing and slinger.

Later Models: The seal face fits into a recess in the underside of the basket hub assembly, as on the earlier model. Also, the seal body installs in the cavity on the top side of the bearing and seal housing as before. However, there is no slinger and the spin bearing is now located in a cavity on the underside of the bearing and seal housing.

Each of the two sealing parts, the seal face and the seal body, have sealing faces which are brought into contact with one another when the basket hub assembly is threaded down on the drive tube. The springs in the seal body exert pressure to keep the sealing faces in contact.

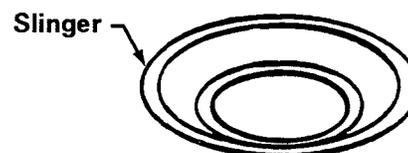
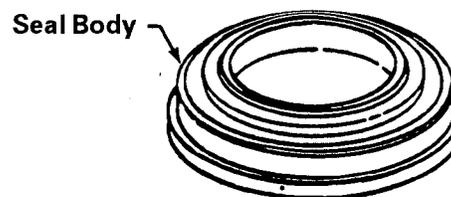
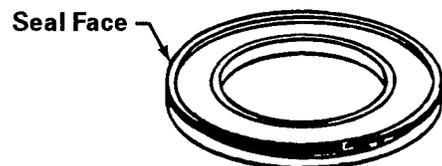

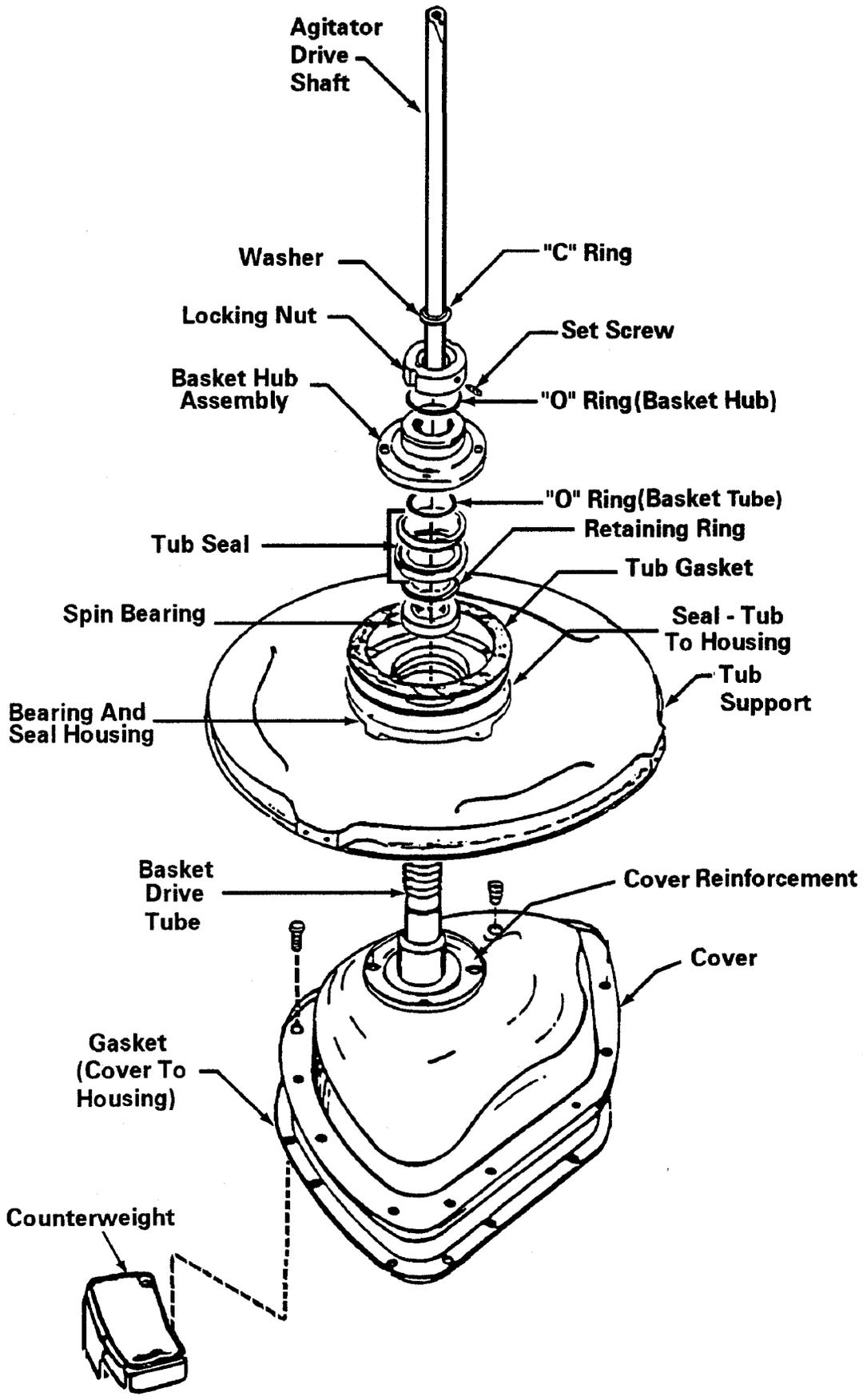

TUB SEAL REPLACEMENT:

Should the tub seal begin to leak or develop excess seal drag, it must be replaced. The service replacement seal includes all the parts necessary to replace the entire seal. Be sure to replace all parts of the seal even if only one part is found to be damaged.

NOTE: *If the tub seal is being replaced because it has begun to leak, the spin bearing is probably defective also and should be replaced. To replace the spin bearing, the bearing and seal housing must be removed as previously described. This also allows access to the tub seal for removal and replacement (refer to steps 2 and 3 below when installing).*

Removal and replacement of the tub seal can ONLY be accomplished as follows:

1. Follow steps 1 through 5 of the bearing and seal housing removal as previously described. The parts of the seal can now be removed from their mounting recesses.
2. Before installing the new seal, coat the mounting recess of the housings with silicone grease (part number 34-7125). This will allow the seal body and seal face to slip into position.

NOTE: *MAKE SURE NO GREASE COMES IN CONTACT WITH THE MATING SURFACES OF THE SEAL.*

3. Make sure both seal mating surfaces are free of foreign matter, then clean both surfaces with an alcohol saturated cloth.

NOTE: *Do not use any agent other than alcohol to clean the mating surfaces, nor any lubricant other than Silicone Grease, part number 34-7125.*

SPIN BEARING

The spin bearing is installed in a cavity on the underside of the bearing and seal housing. It is also press fitted and bottoms out on the cavity shoulder. It is further secured in place by the inner diameter of the tub support.

SPIN BEARING REPLACEMENT:

1. Disconnect the unit from the power source.
2. Remove the bearing and seal housing and the tub support as previously described.
3. Remove the seal body from the housing cavity.
4. Press the spin bearing out of the cavity from the opposite side of the housing.
5. When installing the replacement bearing into the housing cavity, be sure to press against the outer race of the bearing to avoid damage to the bearing shield and causing premature failure.

DRIVE PULLEY AND CAMS

The drive pulley and cam is located below the brake assembly on the drive shaft.

Models are equipped with a plastic drive pulley which has the upper cam molded

onto the bottom of the hub. The purpose of the pulley and cam arrangement is to drive the clutch assembly during the agitate and spin cycle, and to disengage the brake assembly during the spin cycle.

The drive pulley slips over the drive shaft and rests against a series of washers, a thrust bearing, and a large washer type spacer. The spacer locates against the bottom of the brake rotor and lining assembly. (*See the illustration on page 6-7.*)

The lower cam slips over the end of the drive shaft where splines formed in the cam engage with mating splines on the drive shaft end. This imparts a direct drive from the cam to the drive shaft. A shoulder molded on the bottom of the pulley hub engages "dogs" formed on the sides of the lower cam, and will drive it and the drive shaft in either direction.

A washer and retaining ring secure the pulley and cam on the drive shaft. A plastic dust cap snaps to the underside of the pulley to keep the cam surfaces clean.

OPERATION:

When the drive pulley rotates **CLOCKWISE**, the upper and lower cams are designed to nest together which allows the drive pulley to remain in position on the drive shaft. The brake remains engaged and the drive pulley will turn the lower cam and drive the shaft to cause the transmission to agitate.

When the drive pulley rotates **COUNTER-CLOCKWISE**, the upper cam and pulley ride up the lower cam approximately 3/16 of an inch before the driving shoulders on the pulley hub engage the "dogs" on the lower cam.

This causes the top of the pulley hub to push against the spacer which compresses the brake spring and lifts the brake rotor and lining assembly off the brake stator. The brake is disengaged and the pulley will turn the lower cam and drive shaft to cause the transmission to spin.

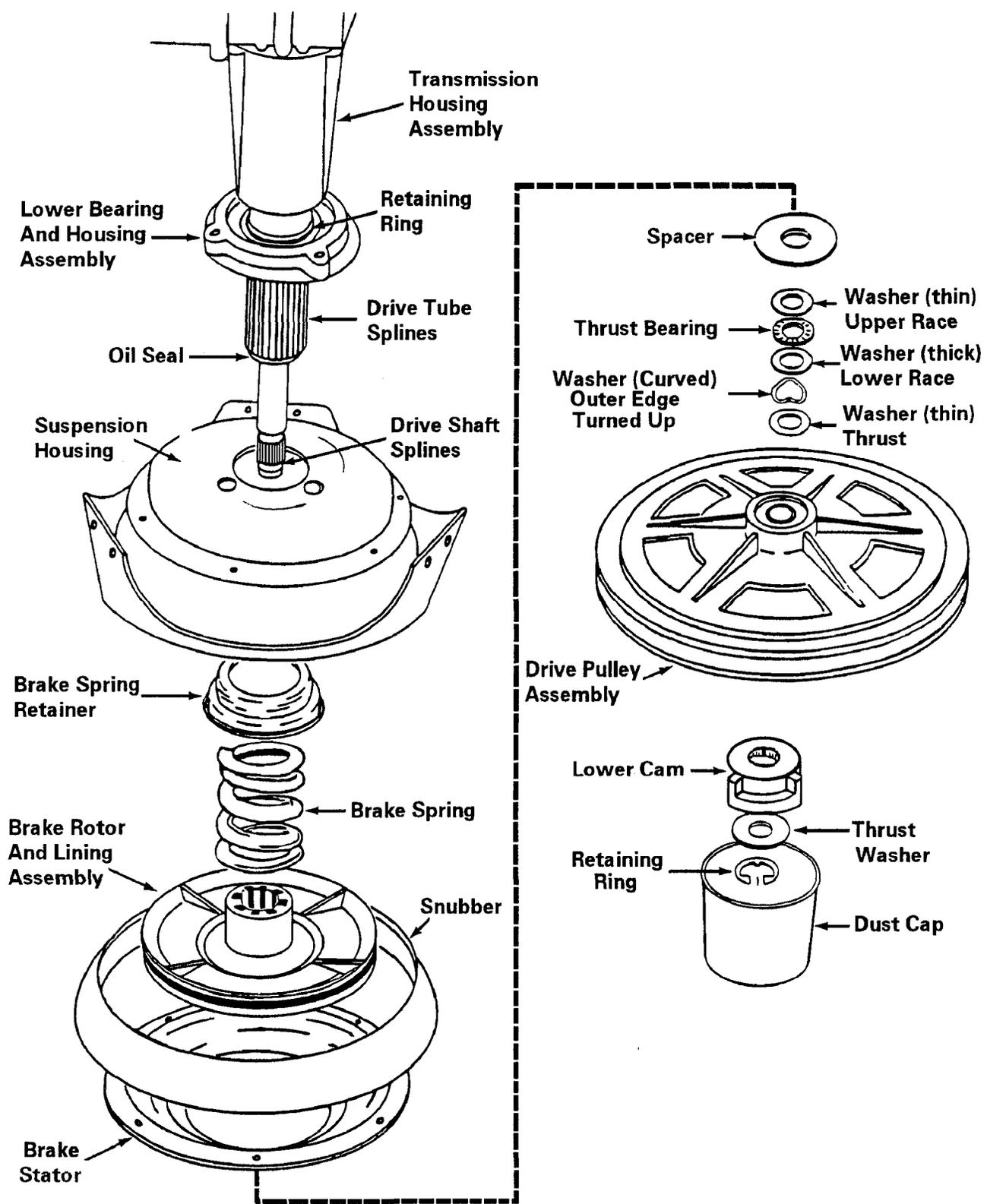

REMOVAL:

1. Disconnect the unit from the power source.
2. Tip the unit over and remove the drive belt.
3. Remove the dust cap from the under side of pulley.
4. Remove retaining ring and washer from end of drive shaft.
5. Firmly pull lower cam off the drive shaft splines, then slide the other parts off the shaft. This will also allow access to the brake assembly for removal.

REASSEMBLY:

After reassembling the components on the drive shaft, it will probably be necessary to pull down on the shaft to take the end play out of it before the thrust washer and retaining ring can be reinstalled.

NOTE: Each time the cams are reassembled on the drive shaft, the point in the cam rise where the brake disengages the stator should be checked and adjusted as necessary.

Reference marks have been molded around the bottom outer edge of the lower cam as an aid in checking the point of brake disengagement (*see following figure*). Each mark, from right to left, represents approximately .010 of an inch cam rise.

To Check Brake Disengagement:

1. Manually rotate the drive pulley in a slow counterclockwise direction until

the brake starts to release and the transmission begins to turn. (*See following figure*).

2. Counting the reference marks on the lower cam from right to left, the pulley hub shoulder should be positioned between reference marks 9 and 3, with 6 being the median. (*Shown in the following figure*).

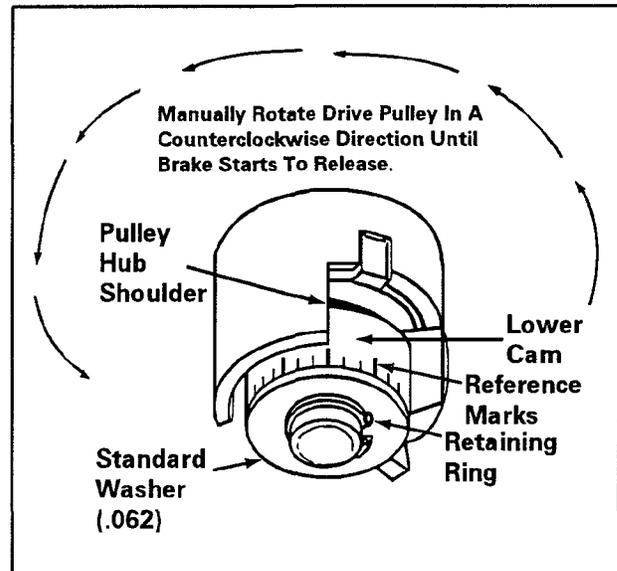

If the position of the pulley hub shoulder **is not** within these parameters and the brake has started disengaging, **adjustment is required**.

To Adjust Brake Disengagement:

1. If the position of the pulley hub shoulder is **less than 3 reference marks**, remove the standard (.062 thickness) thrust washer and replace it with a thinner (.032 thickness) thrust washer (part number 35-2132). Recheck disengagement.
2. If the position of the pulley hub shoulder is **more than 9 reference marks**, add a 35-2132 thrust washer (.032) to the standard thrust washer and recheck disengagement.

BRAKE ASSEMBLY

The brake assembly is located inside the domed area of the suspension housing and consists of the following components: brake spring retainer, brake spring, rotor and lining assembly, and the brake stator.

The brake assembly, as well as the snubber, is held in position by the brake stator which is secured to the underside of the suspension housing by six (6) mounting screws.

Spring pressure forces the rotor and lining assembly down on the brake stator and prevents the transmission from turning during agitation.

As stated previously, the drive pulley and cams provide a cam action which raises the drive pulley during the counterclockwise (spin) direction of the motor. When the drive pulley hub travels upward, it compresses the brake spring and moves the rotor and lining assembly up the drive tube disengaging it from the stator. The transmission is now free to spin.

Splines in the brake rotor hub mesh with splines on the drive tube end to provide positive vertical movement for the rotor and lining assembly. The splines are greased for ease of movement.

CAUTION

The brake assembly has a compressive spring force of approximately 200 pounds. See the following instructions for disassembly.

DISASSEMBLY:

1. Disconnect the unit from the power source.

2. Remove the drive pulley and cam components as previously described.
 3. Using brake removal tool number **35-2442**, proceed as follows:
 - Pull out and remove "U" retainer from tool.
 - Slip the splined end of the drive shaft into hole located in the tool inner plunger.
 - Looking at the side of the tool, align slots on tool barrel and holes in tool plunger between splines and chamfered shoulder of shaft.
 - Slip "U" retainer through tool slots and holes capturing the drive shaft behind the chamfered shoulder.
- NOTE: *Be sure "U" retainer is completely through both sides of tool.***
- Tighten tool nut to compress brake spring *until transmission turns freely.*
 - Remove the six (6) screws which secure the brake stator and snubber to the underside of the suspension housing.
 - Loosen tool nut *until the brake spring reaches its free length.*
 - Remove "U" retainer from tool and remove tool from drive shaft.
 - Remove brake components.

Reinstalling the Brake:

1. Apply silicone grease (part number 34-7125) to the splines of the drive tube and rotor, if needed.

NOTE: *This is a dry operating brake assembly. Make sure no oil or grease comes in contact with the mating surfaces of the brake lining and/or brake stator. Clean both surfaces with an alcohol saturated cloth before reassembly.*

2. Compress the brake spring until the stator and snubber fit firmly against the suspension housing before affixing the mounting screws.
3. Follow the drive pulley and cam reassembly procedure as detailed previously.

BASKET DRIVE TUBE AND COVER ASSEMBLY

The basket drive tube is assembled to the inner top of the transmission cover. A bead of RTV compound, which is impervious to the effects of oil, has been placed between the outer diameter of the drive tube flange and the mounting screw holes. The RTV compound acts as a gasket to seal the drive tube to the cover. Four (4) mounting screws are used to secure the cover reinforcement and the cover to the drive tube flange.

A machined area on the lower part of the basket drive tube rides in the inner race of the spin bearing which is located in the bearing and seal housing. The basket hub assembly is threaded down onto the lower threads of the basket drive tube, securing the assembly. An "O" ring is installed over the tube, and a locking

nut is tightened down on top of the basket hub assembly and "O" ring to lock the assembly in place. The locking nut is further secured by a cup point set screw which threads through the nut and locks on the threads of the basket drive tube.

To compensate for the weight of the gears during the spin operation, a counterweight is assembled to the cover assembly with two (2) mounting bolts.

The cover assembly and gasket are attached to the top of the transmission housing with ten (10) screws.

The basket drive tube and cover assembly can be removed after the bearing and seal housing has been removed.

AGITATOR DRIVE SHAFT AND LINKAGE ASSEMBLY

The agitator drive shaft and linkage assembly consists of the drive shaft and arm assembly, lever assembly, connecting rod, retaining ring, thrust washer, connecting link, and link pins.

One end of the connecting rod fits over the stud on the crank gear. The other end fits onto a stud on the lever assembly and is secured by a retaining ring. The lever assembly fits over a stud mounted in the transmission housing assembly. The circular motion of the crank gear is converted to the oscillating action of the agitator shaft by the linkage assembly.

The agitator drive shaft and linkage assembly can be removed after the basket drive tube and cover assembly have been removed.

NOTE: *The agitator drive shaft and linkage assembly is serviced as a complete unit rather than an individual component basis. The service replacement will come fully assembled, and ready to install. (Shown in the figure on page 6-14.)*

CRANK GEAR

The crank fits over a stud located in the transmission housing assembly. Its purpose is to drive the connecting rod on the linkage assembly.

CLUSTER GEAR

The cluster gear consists of a large gear with a small pinion gear pressed into its center. The cluster gear fits over a stud located in the transmission housing assembly, and is secured to the stud by a retaining ring. The purpose of the cluster gear is to drive the crank gear.

CLUTCH ASSEMBLY

NOTE: *The operation of the clutch assembly and its components has been previously detailed in Section 2, Outline of Mechanical Operation.*

The clutch assembly consists of the drive shaft and hub assembly, clutch spring, drive pinion, and a securing washer and retaining ring.

The drive shaft rides in an upper and lower sleeve bearing located in the drive tube on the lower transmission housing. The three (3) thrust washers (a plain steel washer, a Teflon washer, and a steel washer with tabs on its side) are installed between the drive shaft hub and the inner bottom of the transmission housing.

The transmission assembly must be removed and disassembled before the clutch assembly can be accessed. When the clutch assembly is removed or installed, a seal protector tool (Part Number 14242), must be used to prevent damage to the lower seal. The seal is located in the bottom of the transmission drive tube on the lower transmission housing.

The drive pinion is held on the shaft by a retaining ring and washer. The clutch spring can be removed from the drive pinion and drive shaft hub by a twisting motion. If a colored paint spot is present on the clutch spring, it indicates which end of the spring that is to be installed over the drive hub. If no paint spot is present, either end can be installed over the drive hub. The drive hub is pinned to the drive shaft and is not a replaceable part.

IMPORTANT

When reinstalling the clutch assembly, be sure to lubricate (with transmission oil, Part Number 35-0466) BOTH SIDES of all three (3) thrust washers that are located between the hub and inner bottom of the transmission housing. Replace them in the same sequence they were installed.

Anti-Backup Cam Stop

On later model transmission assemblies, the anti-backup spring has been removed from the clutch assembly and its function replaced with a plastic anti-backup cam stop.

The cam stop is installed over the lower hub of the crank gear and nests in a **deboss** which has been molded in the transmission housing, around the crank gear stud. The deboss traps the cam stop and prevents it from turning. (*See illustration below.*)

When the drive motor turns in the **agitate direction**, the design of the cam stop permits it to **slip** around the cam located on the crank gear hub. This allows the crank gear to turn and drive the linkage assembly.

When the motor reverses and goes into the **spin direction**, the crank gear is allowed to back up until the cam formed on

its lower hub engages a mating notch formed on the cam stop. This interlocks the crank gear and cam stop together. Because the cam stop is trapped in the housing deboss and cannot turn, neither can the crank gear once they are interlocked. Since the locked crank gear also prevents the drive pinion from turning, the torque being delivered by the clutch spring is now exerted against the transmission housing which causes the entire drive train to rotate.

When the crank gear and cam stop interlock, **the linkage assembly is always stopped in the same position**. This allows for a more consistent weight distribution during the spin operation

NOTE: *At the start of the spin cycle, as the crank gear is backing up to engage the cam stop, a momentary movement of the agitator may be observed. The agitator movement will stop when the crank gear properly positions the linkage assembly and interlocks with the cam stop.*

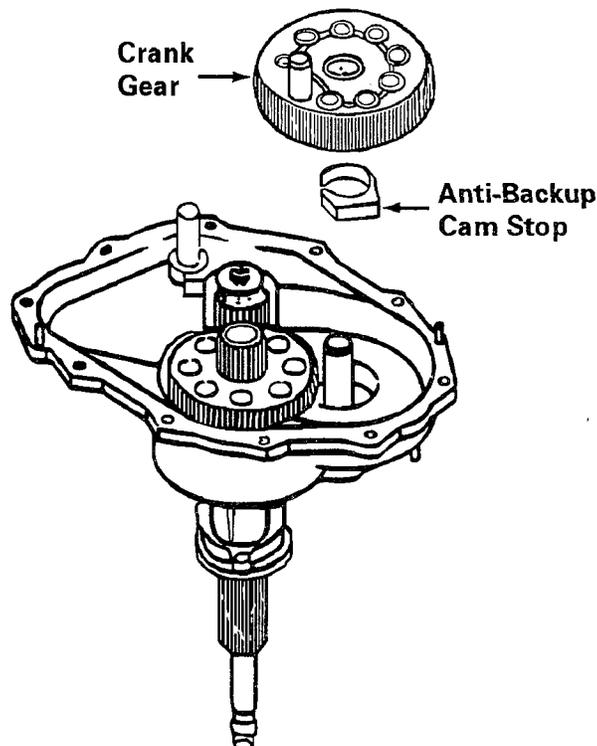

INTERNAL PARTS BREAKDOWN

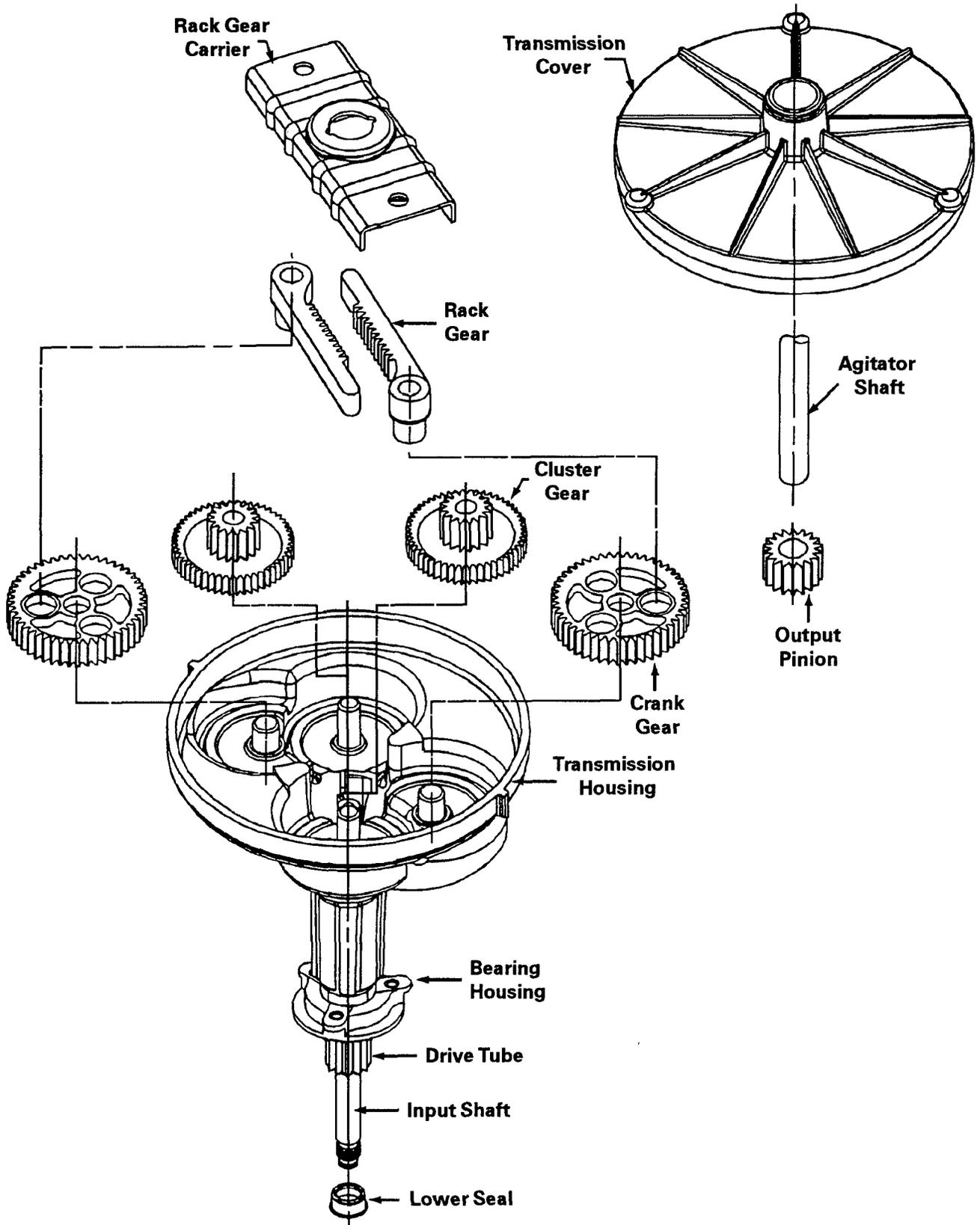

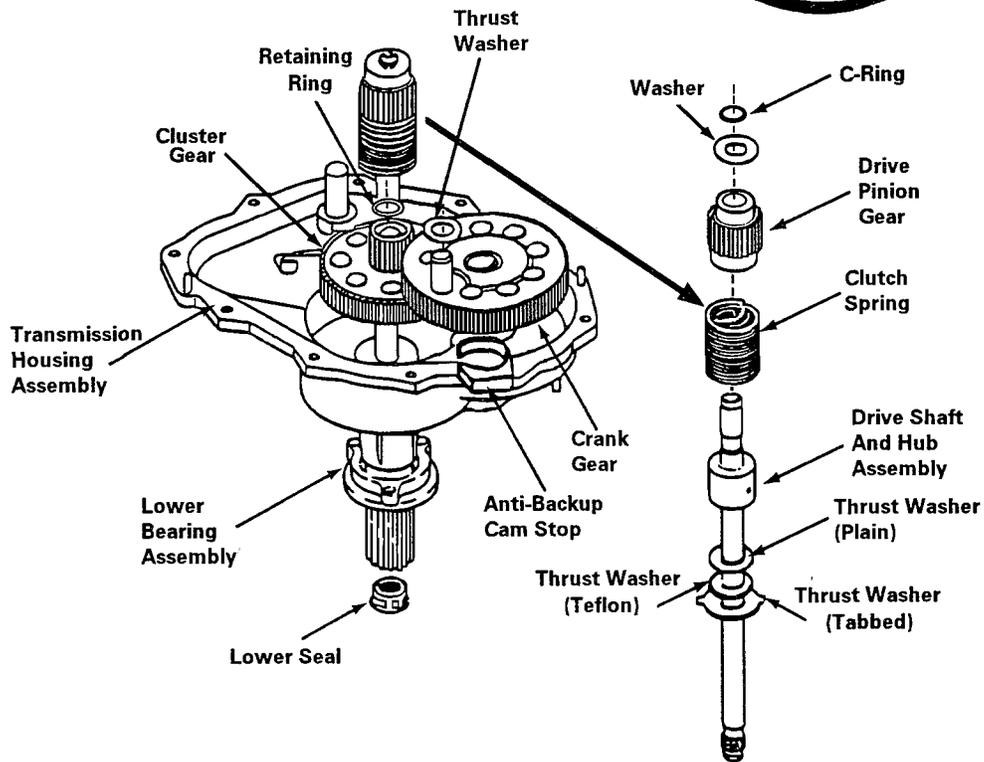
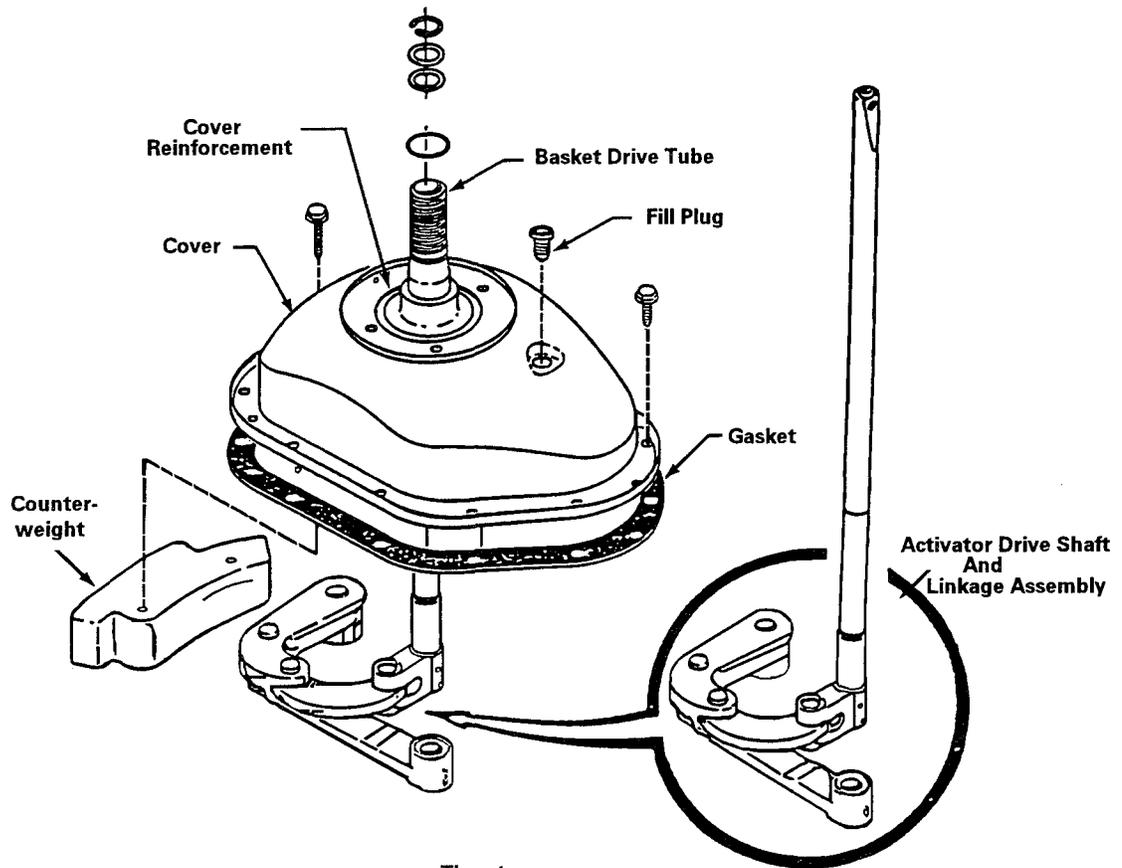

TRANSMISSION HOUSING ASSEMBLY

The die-cast aluminum transmission housing has three (3) steel studs and two (2) locating pins pressed into its upper region. The studs provide mounting for the crank lever, crank gear and cluster gear. The pins properly position the transmission cover and gasket to the housing.

A steel drive tube with a splined end is pressed into the bottom of the transmission housing. Two (2) sleeve bearings have been installed in the upper and lower I. D. of the drive tube for the drive shaft to ride in. The lower bearing assembly is pressed on the drive tube and locates against a retaining ring which is secured to the drive tube. An oil seal is installed in the bottom of the drive tube.

As the studs, locating pins, drive tube, and sleeve bearings are all press fitted into position, in the event that any of them fail, the transmission must be disassembled and the entire housing assembly must be replaced.

NOTE: *This does not include the oil seal or the lower bearing assembly which can be replaced.*

TRANSMISSION HOUSING ASSEMBLY - DUAL DRIVE

The die-cast aluminum transmission housing has four studs pressed into its upper region. The studs provide mounting for the two crank and two cluster gears. The top cover is threaded into the lower housing. A sealant is used on the threads as a gasket material. A steel drive tube with a splined end is pressed into the bottom of the transmission housing. A sleeve bearing is installed in the lower I. D. of the drive tube. Another

bearing is pressed into the lower housing above the drive tube. These bearings provide a path for the drive shaft to ride in. An oil seal is installed in the bottom of the drive tube. The oil seal can be replaced as a separate part.

Oil Seal Replacement:

The oil seal is located in the splined end of the drive tube. The seal can be replaced without removing or disassembling the transmission, as outlined below:

1. Disconnect the unit from the power source.
2. Remove the brake assembly to access the seal.
3. Use a thin, flat bladed screw driver to carefully pry the old seal out.
4. Place the drive washer (From Tool No. 14242) and the new seal over the seal protector (Tool No. 12305).
5. Remove the cone shaped end from the seal protector tool and slide the tool, drive washer, and new seal over the drive shaft up to the seal cavity.
6. Slide the transmission seal driver (Tool No. 14242) over the drive shaft until it makes contact with the drive washer. Use the impact sleeve of the tool to "tap" the seal into the end of the drive tube.

LOWER BEARING ASSEMBLY

The lower bearing assembly consists of a ball type bearing which has been installed in an aluminum die-cast housing. The transmission assembly must be removed from the washer cabinet before the lower bearing assembly can be replaced.

On earlier models, the bearing assembly is pressed onto the drive tube and rests against a retaining ring located just below the point where the tube enters the transmission housing. On later models, the retaining ring has been removed and the lower bearing assembly rests against the bottom of the transmission housing.

The lower bearing assembly provides lateral support for the drive tube and shaft against the tension of the drive belt. The top of the suspension housing is attached to the underside of the lower bearing assembly.

REPLACEMENT:

IMPORTANT

As the lower bearing assembly has been pressed onto the drive tube under approximately 1000 pounds pressure, a puller must be used to remove it. However, the puller forcing screw must not be used on the end of the drive shaft or the clutch assembly could be damaged.

Instead, a simple pipe and cap assembly can be made to slip over the drive shaft, with end clearance, and rest against the end of the drive tube.

The puller forcing screw is used on the end of the pipe cap which directs the forward thrust of the puller to the bottom of the drive tube.

1. Disconnect unit from power source.
2. Remove the transmission from the washer cabinet.
3. Remove the cams, drive pulley and brake assembly.
4. Remove the three (3) screws which secure the suspension housing to the lower bearing assembly.
5. Slip the pipe and cap assembly over the drive shaft and up against the drive tube.
6. Using a puller with at least a 3 1/2 inch spread and sufficient reach to encompass the pipe and cap assembly, remove the lower bearing assembly.

NOTE: *When installing the new lower bearing assembly, be sure to drive against the inner race only to avoid damaging the bearing shield which could cause premature failure.*

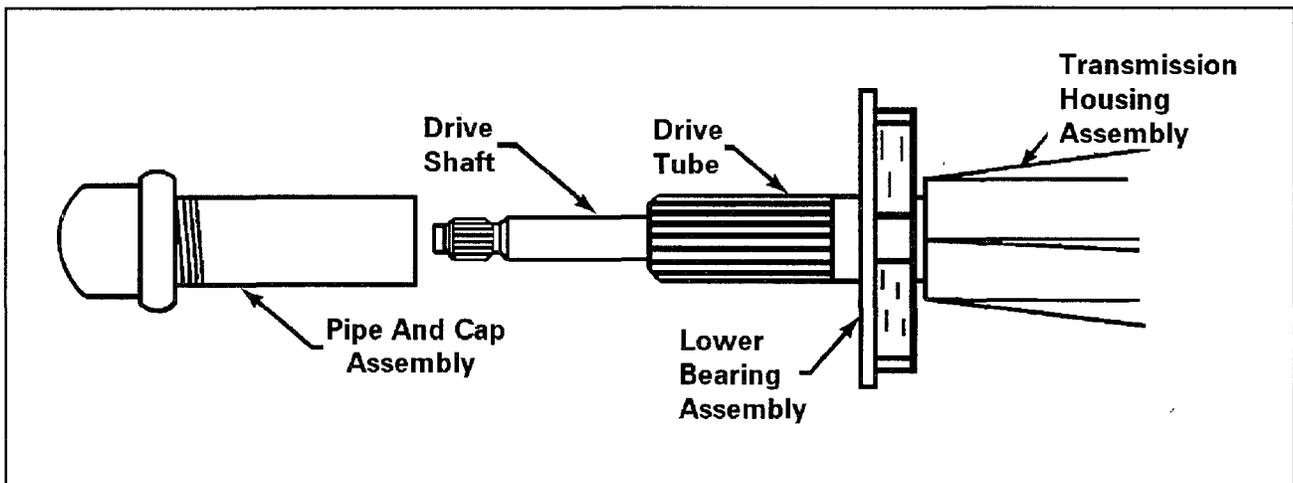

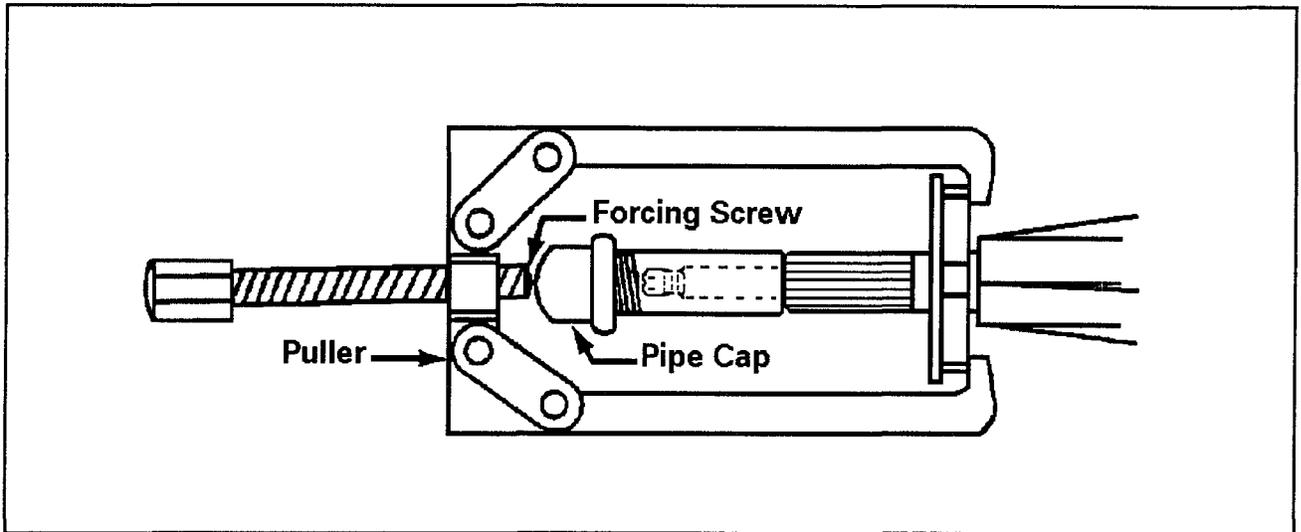

DIAGNOSING TRANSMISSION PROBLEMS

Listed below are most of the service complaints which would normally be caused by a malfunctioning component of the transmission assembly.

Knocking Noise

A knocking noise during agitation can usually be pinpointed by putting a load on the agitator drive block, restricting its motion. If the knocking noise decreases or disappears, it is probably a loose gear. If the knocking becomes louder, a link pin or the connecting link is loose or worn.

Whining Noise in Agitation

The whining noise can be caused by gears not meshing correctly and would only appear during agitation cycles.

Oil Leaks

Oil leaks can be caused by faulty seals, gaskets, or a loose fitting stud or locating pin.

Slow Spin Speed

Slow spin speed can be caused by a binding tub seal and/or bearing, brake rotor assembly not disengaging properly, a slipping clutch spring, or an off balance clothes load. The following test can be used to isolate the problem.

TORQUE TESTING:

A quick test of the efficiency of the spin operation components can be made by placing a 3 1/2 pound weight, such as a bag of sand, in the washer basket and starting the machine in a spin cycle. If the basket appears to reach full spin with the weight, the machine components are performing as intended.

If the basket does not attain full spin speed, the torque test procedures as outlined in the following paragraphs should be performed to determine the problem.

The torque available to drive the spin basket is determined by the amount of drag or resistance presented by the tub seal and spin bearing, deducted from the input torque imparted to the transmission housing assembly by the clutch assembly.

The Following Torque Tests Will Allow a Problem in the Spin Drive Train to be Pinpointed:

NOTE: Before starting these tests, the washer should be operated in the agitation cycle with hot water for about two (2) minutes, and then for two (2) minutes in a spin cycle. This warms up the transmission oil and the spin drive train components.

Available Torque

Place a 1/2 inch socket and torque wrench on the agitator retaining bolt.

Depress the safety spin switch to allow the washer to operate in the spin cycle, then while reading the torque allow the wrench to turn slowly (about 6 R.P.M.) through a complete 360 degree cycle. The reading should be between 18 and 25 inch pounds throughout the complete 360 degree rotation of the wrench.

If the torque readings are within these limits, the washer is performing properly and any slow spin complaints can be assumed to have been the result of off-balance loads.

If the torque reading exceeds 25 inch pounds, the input torque outlined later should be checked to determine the cause. Probable causes are that the drive shaft is binding in the transmission housing (drive tube) sleeve bearings, or that the clutch spring is binding on the drive shaft hub.

If the available torque reading is less than 20 pounds, follow the procedure for testing the drag torque.

Drag Torque

Position the washer so the drive pulley can be accessed, and remove the drive belt. While holding the transmission to keep it from turning, manually rotate the drive pulley counterclockwise ***until the brake stays disengaged***. Make certain the drive pulley hub shoulder has rotated fully against the cams in the spin driving position to ensure the complete disengagement of the brake. Release the transmission so it is free to turn.

Place a 1/2 inch socket and torque wrench on the agitator retaining bolt.

Slowly rotate the wrench 360 degrees at approximately 6 R.P.M. and read the torque. If the torque reading is over 4 inch pounds, remove the brake stator (as detailed earlier in this section) and recheck the drag torque.

If the torque reading is now under 4 inch pounds, the brake is binding and should be repaired.

If the reading is still over 4 inch pounds, the tub seal and/or spin bearing is binding and should be replaced.

If the ***available torque*** reading is below 18 inch pounds and the ***drag torque*** reading is not over 4 inch pounds, follow the procedure for checking the clutch assembly as to its input torque.

Input Torque

NOTE: *It will be observed that the readings used to check the input torque are slightly lower than the readings used to check the available torque. The reason for this is when the brake is disengaged, as in checking the available torque, the compressed brake spring exerts a downward force on the bottom of the clutch hub and thrust washers. This keeps the clutch spring from slipping quite as readily as in checking the input torque where the brake is engaged and the downward force on the clutch hub is minimized.*

To check the input torque, remove the drive pulley and position the washer so the scale on the torque wrench can be read when it is placed on the input (drive) shaft. Attach the torque wrench adapter ***firmly*** to the shaft, place the wrench in the adapter and slowly rotate the wrench in a counterclockwise direction. A properly operating clutch assembly will have a torque reading between 17 and 20 inch pounds.

If the input torque is less than 17 inch pounds, the clutch assembly is defective and must be repaired or replaced.

If the input torque exceeds 20 inch pounds, remove the clutch assembly from the transmission. Secure the drive

pinion in a vise using two (2) small blocks of wood to prevent damage to the gear teeth, and repeat the input torque check.

If the torque reading is between 17 and 20 inch pounds, the drive shaft is binding in the sleeve bearings.

If the torque reading still exceeds 20 inch pounds, the clutch assembly is *defective* and must be repaired or replaced.

TRANSMISSION REMOVAL:

The transmission assembly can be removed from the washer cabinet after removing the drive belt, spin basket, outer tub and the suspension springs.

NOTE: *Be sure to dust the base dome lightly with corn starch before installing the transmission.*

CAUTION

Once the agitator has been removed, the center post slips off the shaft. Therefore, do not attempt to handle the drive train by the center post after the agitator has been removed. Instead, after removing the agitator and the agitator shaft "O" ring, slip the center post off the shaft and handle the drive train by the shaft.

NOTE: *If the "O" ring is to be reused, be extremely careful not to damage it during the removal.*

Reinstall the center post, "O" ring and agitator once the drive train is back in place.

NOTE: Service replacement drive trains will have a disposable center post "hold down" so that it can be handled during packaging and installation. Once the assembly has been installed, the "hold down" is removed and discarded before installin the agitator.

The transmission assembly, when recoved as described, will have the related components assembled to it. These related components should sbe examined carefully before reinstalling.

IMPORTANT

When installing the transmission, it is necessary that the tub be located on the tub support a certain way if all the mounting holes are to be properly aligned. This should be done before attempting to mount the tub to the bearing and seal housing.

To assist in correctly positioning the tub, a small indentation has been formed on the tub support just above one of the tub brace mounting areas. This is the left front tub brace.

When the tub is in proper position and ready to be mounted to the tub support, the large tub cover lock (on the side of the tub) should be located directly above the indentation and tub brace.

(See the illustration on page 6-20.)

Transmission Disassembly:

1. Remove the center post assembly.
2. Remove the "C" ring and washer located on the agitator shaft just above the basket drive tube.

3. Remove locking nut.
4. Unscrew and remove the basket hub assembly (tool numbers 35-2968).
5. Lift up on the bearing and seal housing with the support attached, and remove.
6. Remove the screws that secure the cover assembly to the transmission housing.

NOTE: The oil level in the transmission is above the top of the transmission housing. BE SURE TO HAVE SOMETHING UNDERNEATH TO CATCH THE OIL.

7. Lift the cover assembly up and over the agitator drive shaft.

NOTE: To prevent possible damage to the drive tube bearing, use a small file and smooth any areas on the agitator drive shaft that restrict the cover assembly during removal.

8. After the cover assembly has been removed, lift up on the agitator drive shaft and linkage assembly to remove.
9. Lift up and remove the crank gear.
10. Remove the retaining ring which secures the cluster gear to the stud, and remove gear.
11. Remove the dust cap from the under side of drive pulley.
12. Remove the retaining ring and washer from end of clutch drive shaft.

13. Firmly pull lower cam off the drive shaft splines, then slide upper cam, drive pulley, washers, bearing, and spacer off the shaft.
14. The clutch assembly can now be lifted from the transmission housing assembly.

NOTE: *The oil seal should be protected before removing the clutch assembly from the housing if the seal is not to be replaced. However, oil seal replacement is recommended after the clutch assembly has been reinstalled.*

15. Remove the brake assembly as detailed earlier in this section.
16. Remove the suspension housing and lower bearing assembly as detailed earlier in this section.
17. The transmission is reassembled in the reverse order of disassembly.

IMPORTANT

- Before replacing the cover assembly over the agitator drive shaft, fill the lower shaft groove with transmission oil. This ensures proper lubrication of the drive tube bearing.
- Apply anti-seize compound (steel to aluminum) to the drive tube threads before installing the basket hub assembly. Anti-seize compound is available at most automotive stores.

OIL REQUIREMENTS

The transmission is charged with 38 ounces of oil (part number **35-0466**). This is a special oil and no other oil should be substituted.

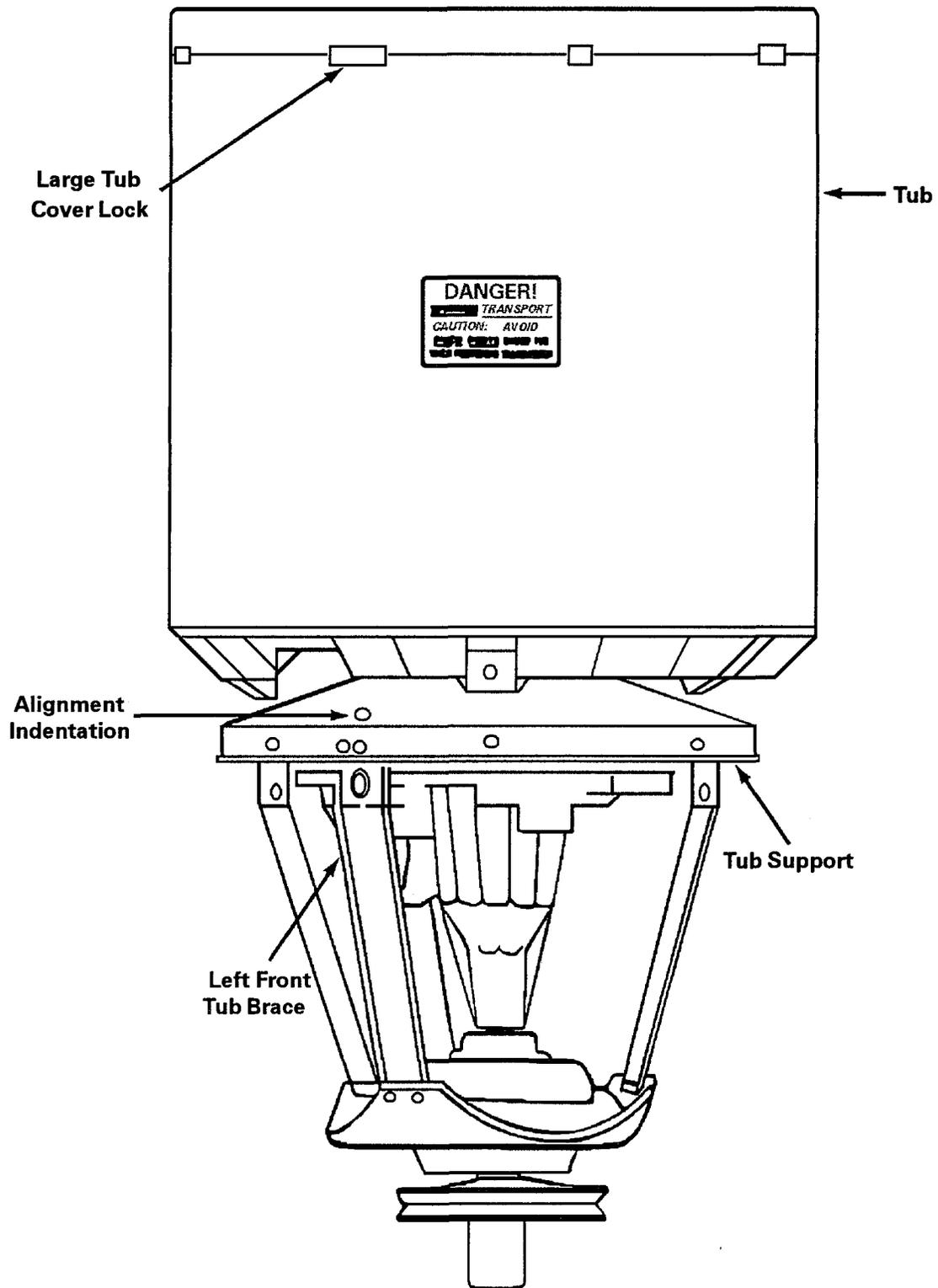

TUB TO TUB SUPPORT ALIGNMENT

SECTION 7. ELECTRICAL COMPONENTS AND TESTING

TIMER

The timer is mounted to the control shield, located inside the control panel assembly. The timer shaft protrudes through the control panel and provides for the selection of the various machine cycles available.

The timer is an incremental advance, rotary type driven by a synchronous motor. The timer controls and sequences the numerous steps and functions involved in each machine cycle. It accomplishes this by providing power to the various electrical components through the opening and/or closing action of timer contacts.

A typical timer and plug connector are illustrated in the following figure. The timer has all the connecting points brought out to miniature spade terminals. These terminals are centralized and aligned on one side of the timer to form a terminal board.

The connecting wires from the wiring harness are terminated in a compatible connector which plugs into the timer terminal board.

Since space is notably limited on the timer terminal board, terminal identification is provided by a sticker attached to the side of the timer. When referring to the sticker for terminal identification, the external timer motor wires can be used for orientation.

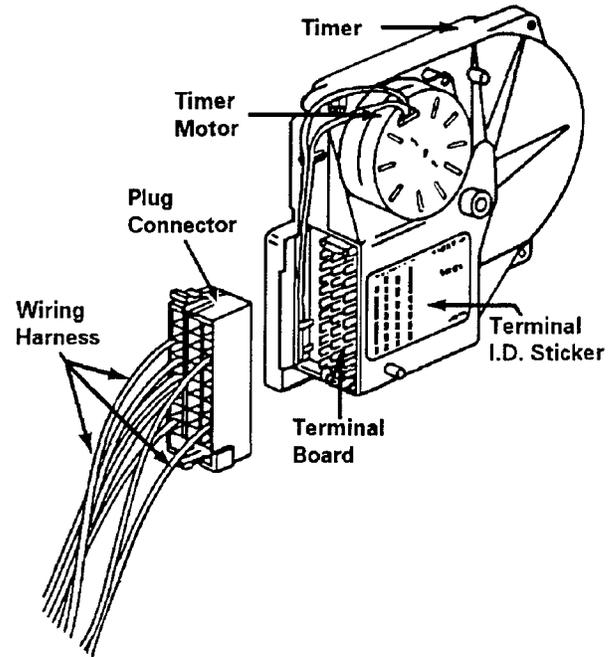

Another source for terminal identification is the schematic diagram which is supplied with each washer. The schematic diagram not only identifies the terminals, but also the plug connector terminals and their respective wire colors.

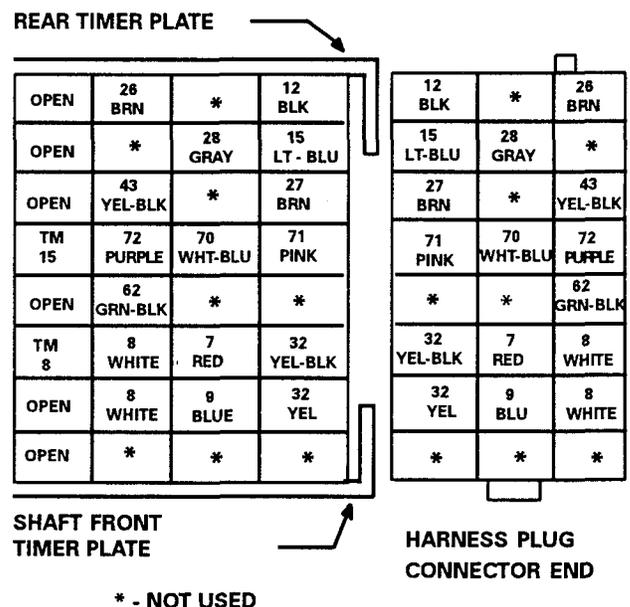

REMOVAL:

Timer removal procedures are detailed in Section 3 under *Control Panel Disassembly*.

Timer Testing:

The timer can be tested by using an ohmmeter and the *Timer Sequence Chart* as detailed following.

TIMER SEQUENCE CHART

The following chart depicts a typical *Timer Sequence Chart* which can be found on the schematic diagram. It denotes the internal timer contacts which are opened and/or closed by the timer cam switches at any interval during a machine cycle.

Listed down the side of the chart at the left, each contact in the timer is identified as being controlled by a particular cam. The function of each contact and its terminal designation is also indicated.

Across the bottom of the chart are the various machine cycles available for selection, and the timer increments at which the cycle begins, proceeds and ends. The increment, or degree division, indicates the travel of the timer through a cycle.

The heavy black lines to the right of the terminal column indicate a closed contact. If the contact is open, there is a break in the heavy black line.

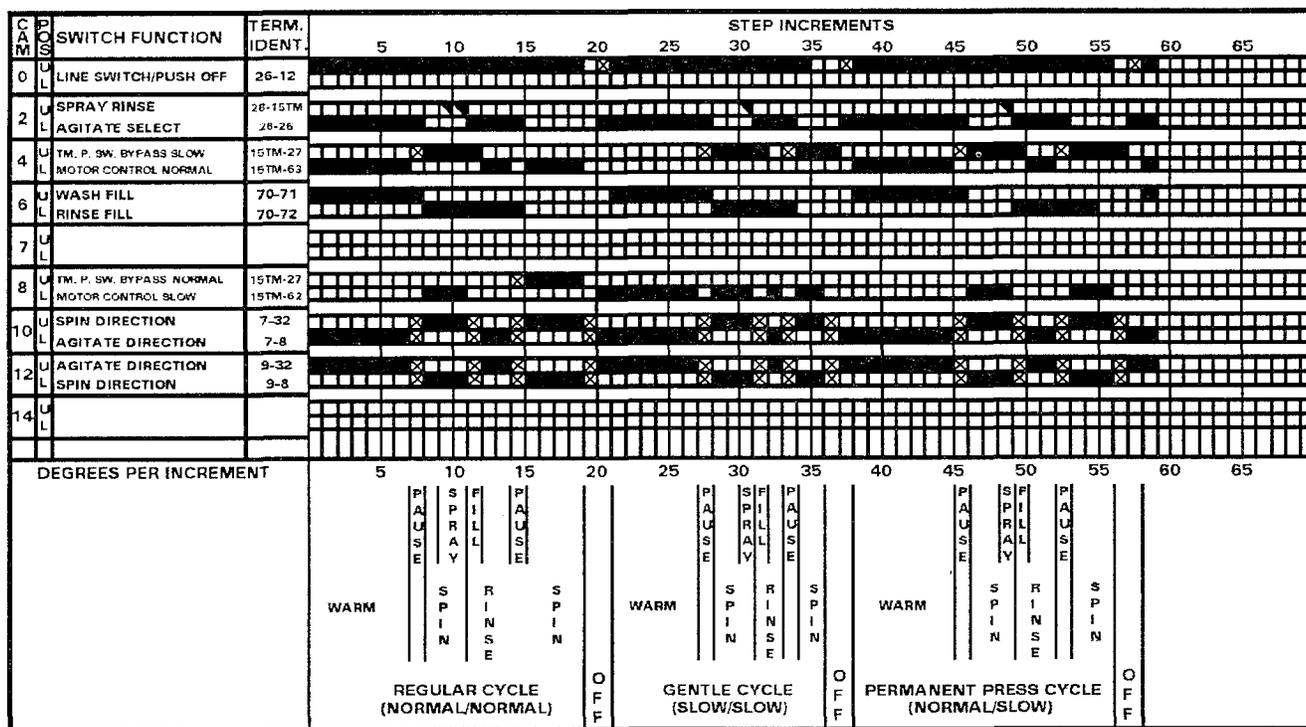

EXAMPLE

Cam OU shows the switch arm closed, making contact between terminal 12 and 26 from increments 1 through 18. This circuit is the cam controlled ON/OFF switch in the timer and at increment 19 it opens, shutting the machine off.

Using the Time Sequence Chart:

The sequence chart used in conjunction with an ohmmeter can be quite effective when attempting to verify or diagnose problems in the timer, wiring, or other electrical parts.

In order to establish exactly which electrical components should be operating during any given time throughout the various machine cycles, it is only necessary to determine what particular cycle and phase of the cycle you are interested in.

Once the cycle and phase have been ascertained, locate these along with the increment at the bottom of the **Timer Sequence Chart**. When the cycle, phase and increment are located, follow the increment from the bottom to the top of the chart noting which timer contacts are involved in the area of concern.

Once the timer contacts have been determined, the electrical circuits involved can be traced on the connection diagram by increment or by phase, if necessary.

A point to point continuity check can be made to isolate the trouble either in the timer, wiring harness, or other electrical components after the circuit has been traced.

MOTOR

All washers are equipped with split phase reversible motors (*see the following figure*). The motor is 3/4 H.P., two speed. The motors have a four (4) pole and a six (6) pole winding and run at 1725 RPM or 1149 RPM respectively.

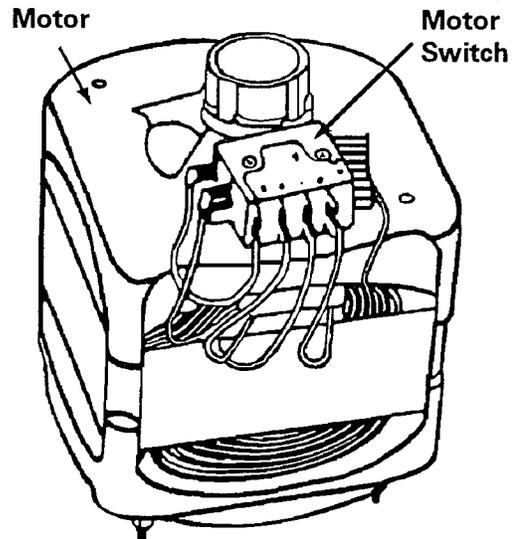

Each motor has an internal overload protector which will react to a temperature rise and/or excessive amperage draw. The overload protector is wired in series with the line, and all power to the machine is cut off if the protector switch opens. The protector switch is not field serviceable and if it fails, the motor must be replaced.

MOTOR SWITCH

The externally mounted motor switch is a mechanically operated device used to control the power input when the motor starts.

On two speed motors it is necessary that the 4 pole winding, the normal speed winding, be in the circuit each time the motor starts even if the speed selector control is set for slow speed operation.

The wiring on two speed motors is arranged so that the motor switch directs power to the normal speed winding and the start winding to start the motor. When the motor reaches switching speed, the switches move opening the circuit to the start winding and at the same time transferring the power from the normal speed winding to the slow speed winding.

Motor and Switch Operation:

The polarity of the magnetic field of the start winding, in relation to the magnetic field of the run winding, determines the direction of the rotation of the motor.

The timer is used to reverse the polarity of the start winding field and the operation of the motor start switch. *(See the line drawings as illustrated on page 7-5.)*

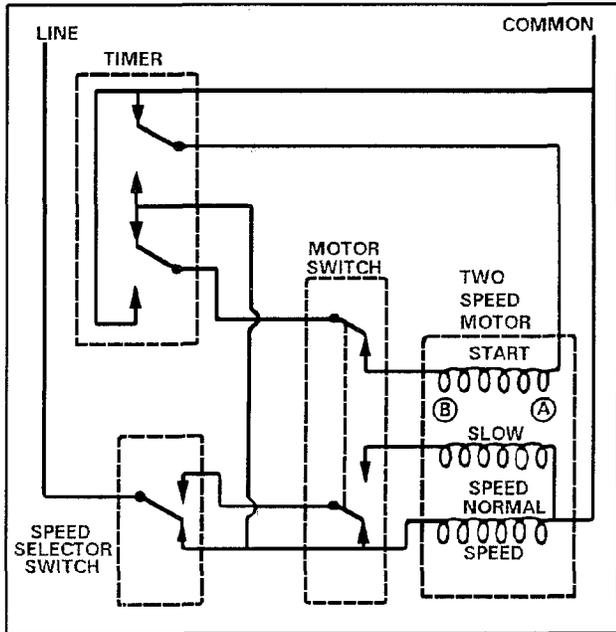

Side A of the start winding is connected to the common side, B is connected to the line through the motor switch. The speed selector switch is set for normal speed operation.

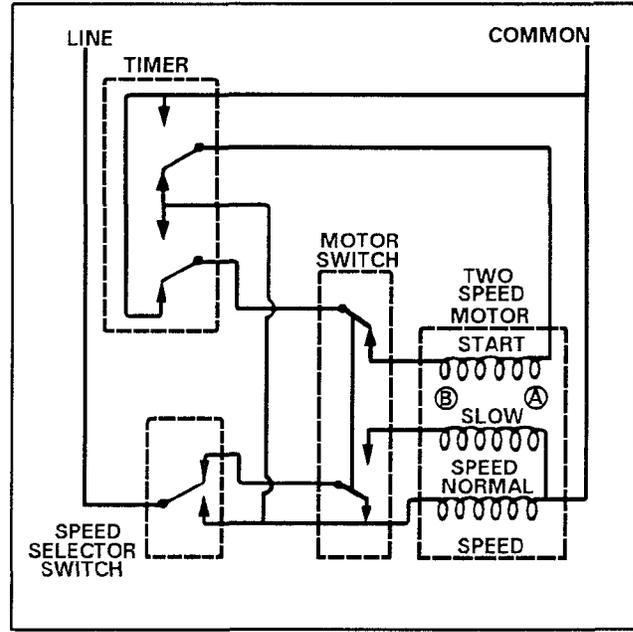

The timer selection has been changed, now side A of the start winding is connected to the line; side B is connected to the common side through the motor switch. The speed selector switch is set for slow speed operation. The motor switch is supplying power to the normal speed motor winding.

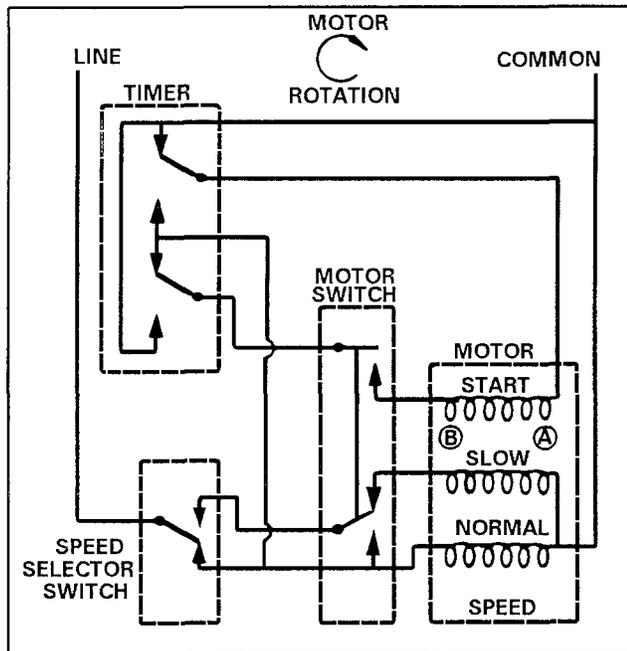

As the motor starts running, the motor switch moves opening the start winding circuit. The motor is running on the normal speed winding in the direction indicated.

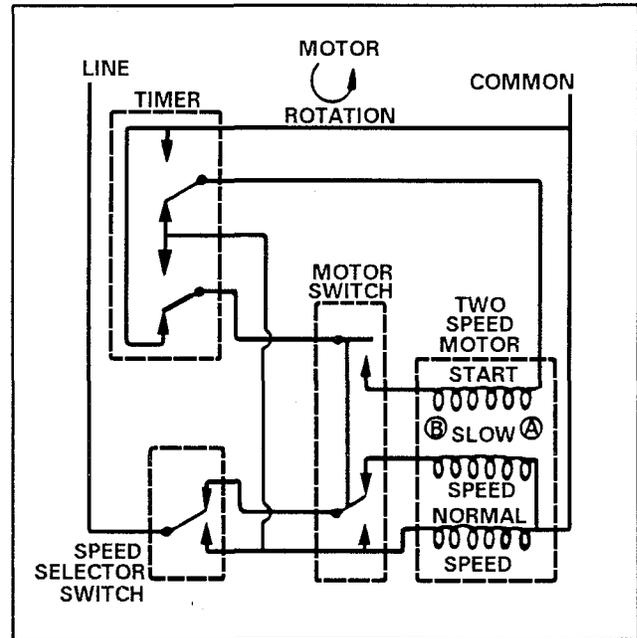

As the motor starts running, the motor switch moves opening the start winding and transferring the power from the normal speed winding to the slow speed winding. **The motor is running on the slow speed winding in the direction indicated.**

MOTOR MOUNTING

The motor mount system consists of a motor and mounting plate assembly as shown in the following figure.

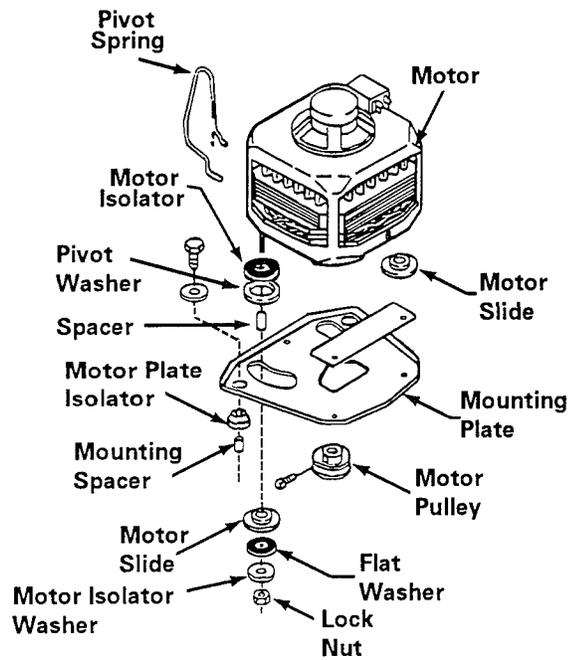

Assembled to the motor studs and secured by locknuts are rubber isolators and washers which sandwich nylon washers and slides through slots in the mounting plate. A nylon slide is attached to the motor bottom, and a pivot spring installs between the motor and mounting plate.

In operation, the nylon washers and slides ride in the slots in the mounting plate, and the slide rides the mounting plate. The motor is free to pivot in either direction and the pivot spring assures proper belt tension on the motor pulley.

The mounting plate has rubber mounting cushions assembled to its rear corners, and the entire assembly is mounted to the washer base by two (2) large hex head screws.

REMOVAL:

1. Disconnect the unit from the power source.
2. Tip washer and remove drive belt.
3. Remove the front panel.
4. Remove the two (2) large hex head screws which secure the motor and plate assembly to the base.
5. Remove the screw which secures the wiring clamp to the top of the motor. Disconnect the necessary wiring.
6. Remove the motor and plate assembly from the base.
7. To separate the motor and plate assembly, remove the motor pulley and the two (2) lock nuts which secure the components to the motor studs.

IMPORTANT

After reassembling the motor to the plate, be sure the nylon washers and slides move freely in the radiused slots. In cases where washers and slides do not move freely, the sides of the slots may be bent and require alignment. Check the slots for a rough surface or for oil and dirt which must be removed.

Jenn-Air washers are equipped with a nylon/glass filled motor pulley. This pulley is pressed onto the motor shaft where splines formed inside the pulley mesh with mating splines on the motor shaft. Small barbed fingers molded onto the front of the pulley hub, snap into a groove located at the end of the motor shaft.

NOTE: *The center hole of the motor plate is large enough to provide clearance for the pulley during motor and plate assembly.*

To eliminate the necessity of having to remove and replace the nylon/glass filled pulley when installing a replacement motor, the complete motor/pulley and plate assembly will be serviced (*as shown in the illustration*) ready to be mounted to the base. However, should a nylon/glass filled pulley become damaged in the field, a service replacement pulley is available. The pulley can be removed and replaced as follows:

REMOVAL: It is necessary to use a puller with at least a three (3) inch spread.

INSTALLATION:

1. Remove the shaft cover at the rear of the motor and "backup" the end of the motor shaft with a socket. This will prevent internal damage to the motor when tapping on the opposite end of the shaft during pulley installation.
2. With the hub fingers out, position the pulley over the motor shaft until the splines begin to mesh.
3. Place a 1/2 inch I.D. deep socket, pipe, etc., over the hub fingers and ***gently*** tap the pulley over the splines until it bottoms out on the shaft shoulder.

NOTE: *When the pulley has been properly positioned against the shaft shoulder, the hub fingers at the pulley front should be located in the shaft groove.*

4. Replace the shaft cover at the rear of the motor and reinstall.

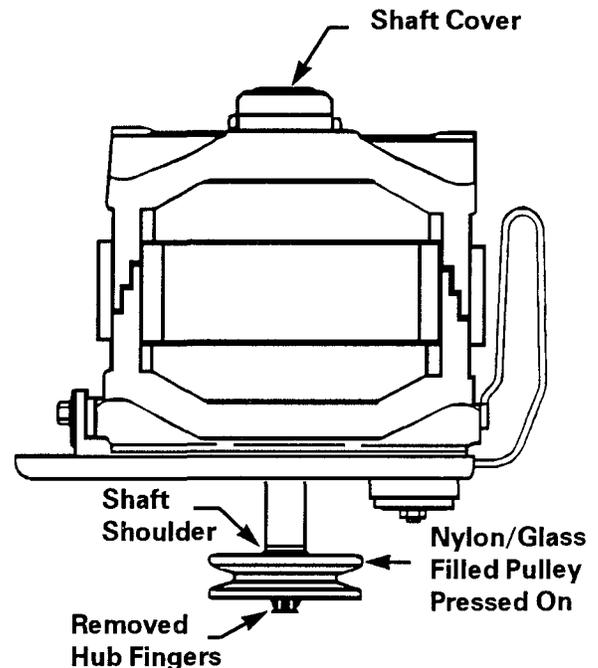

MOTOR CIRCUIT TESTING

The motor overload protector, motor starting switch and the motor are the three components that should be tested if the motor assembly is suspected of being the cause of a service problem. The power cord should be unplugged and all wiring connections from the machine wiring harness to the motor starting switch should be disconnected before any testing is done to the motor.

Overload Protector

The overload protector is built into the motor and is not serviceable. The contacts of the overload protector are normally closed and open in response to a temperature rise, an excessive amperage draw or a combination of both. The contacts reset automatically when they cool off. All automatic washers are

wired with the power line and if the contacts open, all power to the machine components is cut off.

If the overload protector opens repeatedly, check the following:

1. A binding condition in the motor or in the drive train.
2. Poor electrical connections causing a low voltage situation.
3. The motor overheats because of a restricted air flow. (The motor can get as hot as 200 degrees Fahrenheit and still be operating within design specifications.)

Motor Switch

The motor switch has two sets of contacts which operate simultaneously. One set controls the start winding circuit. The second set feeds the normal speed cycle, and then switches the circuit to the slow speed winding.

To check the motor switch, connect a continuity tester between terminal 4 on the switch and the unmarked single terminal, toward the back of the switch, on the opposite side. The tester should indicate a closed circuit. When the switch button is depressed, the tester should indicate an open circuit. Now, check continuity between terminals 5 and 3. The tester should indicate a closed circuit in both tests. Next, connect the tester between terminal 5 and the unmarked single terminal next to terminal 3 and depress the button. The tester should indicate continuity.

If the machine will not run at all, use a continuity tester to check the overload

protector by reading from the P to P terminals at the motor switch.

Motor

If the motor runs in one direction but will not reverse, the problem is in the timer or wiring harness, not in the motor. The same motor components are used when the motor runs in either direction; the only change is in the electrical circuitry feeding the start winding which is controlled by the timer and related wires.

A two conductor test cord which has two female spade connector terminals on each conductor is needed to test the motor operations (tool number **038183**).

To test a motor, connect the two spade connectors on one side of the cord to terminals 1 and 4 on the starting switch and the two connectors on the other side of the cord to the starting switch terminals 2 and 3.

To check the low speed operation, change the lead on terminal 3 to terminal 5. Be sure to test the motor in its normal vertical position. If the motor will not start, or if it starts but does not attain normal speed, check the operation of the external motor switch, replace the motor.

NOTE: Normal resistance of the motor windings should be:

| | |
|------------|----------|
| HIGH SPEED | 1.3 OHMS |
| LOW SPEED | 2.3 OHMS |
| START | 3.1 OHMS |

WATER MIXING VALVE

The water mixing valve is secured inside the right rear cabinet by two (2) mounting screws.

The mixing valve has two solenoids, one on the "**HOT**" water side and another on the "**COLD**" water side. These solenoids are energized through the timer and water temperature selector switch and will allow **COLD**, **HOT** or **WARM** (a mixture of **HOT** and **COLD**) water to enter the tub as directed.

Testing Mixing Valve

The mixing valve can be accessed by raising the top. The valve can be tested using an ohmmeter and performing the following:

1. Disconnect the unit from the power source.
2. Remove all wiring from the solenoid(s) being tested.
3. Place the test leads across the terminals of the solenoid being tested. The meter should indicate continuity.

NOTE: *Normal resistance of each coil is approximately 860 ohms.*

4. Place one test lead on one terminal of the solenoid being tested, and place the other lead on a suitable ground. The meter **should not** indicate continuity.

WATER LEVEL SWITCH

The water level switch is secured to the control shield, which is located inside the control panel assembly, by two (2) mounting screws.

The water level switch is operated by a column of air that becomes trapped in

the pressure switch hose. This hose is connected between the diaphragm section of the switch and the air bell which is located on the lower portion of the tub. As water enters the tub, a small amount enters the pressure switch hose thereby trapping air in the hose. As the water level increases in the tub, this column of air becomes compressed and exerts pressure on the water level switch diaphragm. When the proper water level is reached the diaphragm actuates a single pole, double throw switch in the water level switch assembly.

The water level switch is quite sensitive and requires only about 0.6 P.S.I. to activate it at the maximum fill position. Therefore, it is most important that the hose connections to the switch diaphragm and air bell nipple be airtight, as the smallest air leak will cause erratic operation.

IMPORTANT

The water level switch is adjusted and sealed at the manufacturing source and **no adjustments should be made in the field.**

Whenever the hose is removed from the water level switch or the air bell nipple, **DO NOT** reconnect the hose until all water has been drained from the tub. To assure proper operation of the water level switch, the hose **MUST NOT** have any water in it when reinstalled on the switch. When reconnecting the hose, be sure to slip it over the nipple(s) as far as possible and always replace the hose clamp(s).

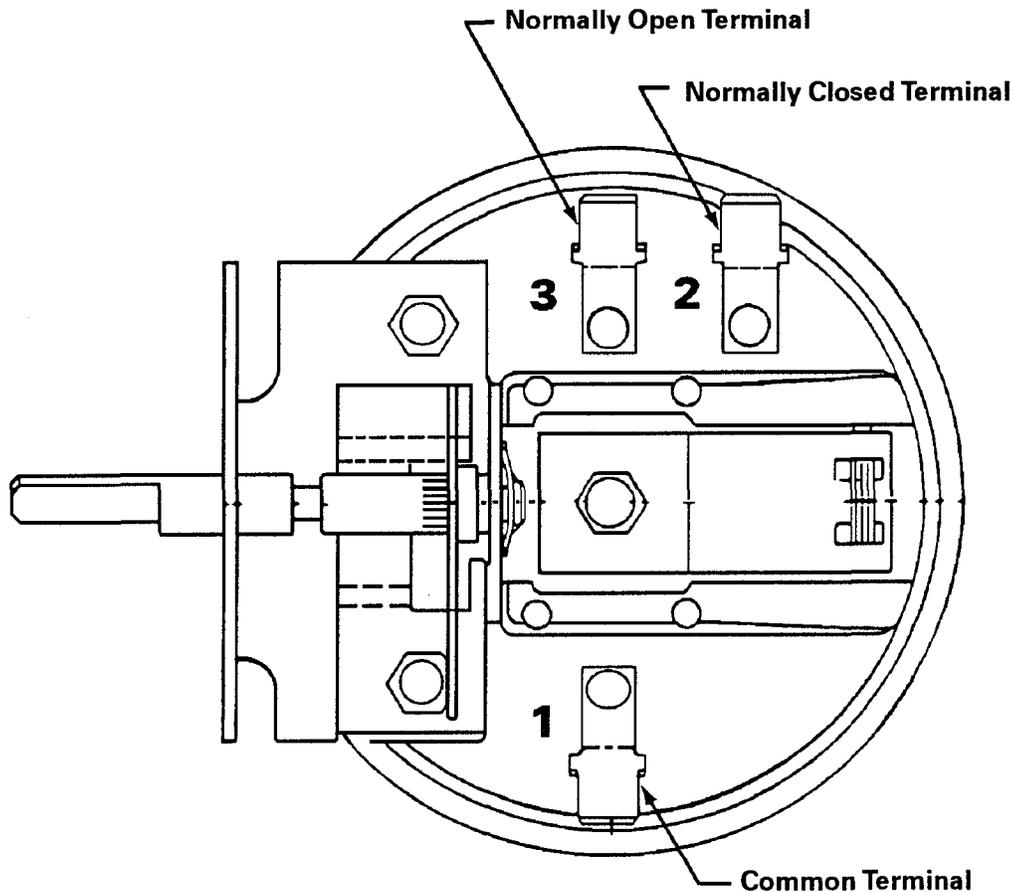

Water Level Switch Operation

The circuitry of the machine is designed to put the switch in control of the water mixing valve or the timer motor and drive motor during various phases of the wash cycle.

During the fill cycle, the switch makes a circuit between its contacts 1 and 2 which energizes the mixing valve circuit(s). When the switch is activated, it opens the circuit between contacts 1 and 2 which shuts off the water, and closes a circuit between contacts 1 and 3 which energizes the timer motor and drive motor.

Testing the Water Level Switch

The water level switch can be accessed as previously detailed in **Section 3** under **Control Panel Disassembly**. It can be tested using an ohmmeter and executing the following:

- When the tub is empty, ohmmeter leads placed across terminals 1-2 should indicate continuity.
- When the tub is filled as per the switch setting and corresponding water depth (*refer to Specifications Section under Water Level*), terminals 1-2 should be open and terminals 1-3 should indicate continuity.

SELECTOR SWITCHES

On some models, the inlet water temperature and the motor speed are controlled by the timer, but most models employ a separate switch or switches to control these items.

The switches used may be a rotary type, pushbutton type, or some models may use both types.

Selector switch charts indicating the contact alignment for the various positions of each switch used appear on the schematic diagram. These charts should be referred to for specific information on the model being serviced. Typical selector switch charts are shown in the following tables.

| SPEED SELECTOR SWITCH | |
|-----------------------|-----------------|
| POSITION | CIRCUIT |
| N - N | 64 - 66 67 - 65 |
| S - N | 64 - 65 67 - 66 |
| S - S | 64 - 65 67 - 65 |
| N - S | 64 - 66 67 - 65 |

| WATER SELECTOR SWITCH | |
|-----------------------|----------------------|
| POSITION | CIRCUIT |
| H - C | 17 - 19 |
| H - H | 17 - 18 - 43 |
| H - C | 17 - 18 - 19 |
| C - C | 17 - 18 |
| STAIN I | 17 - 18 - 19 66 - 68 |

Testing Selector Switches

The selector switch can be accessed as previously detailed in **Section 3** under **Control Panel Disassembly**. It can be tested using an ohmmeter and executing the following:

- Remove all switch wiring and perform continuity checks using the respective selector switch chart to indicate the proper continuity.

SAFETY SPIN SWITCH

The safety spin switch assembly is constructed of thermoplastic. The safety spin switch, bracket, lever, and clip are mounted to the underside of the cabinet top. The switch is a single pole, throw type with normally open contacts.

A switch actuator is installed on the clothes door and protrudes down approximately 3/4" below the bottom edge of the door.

When the door is closed, the switch actuator passes through a slot in the cabinet top and contacts the switch lever. The switch lever is moved downward causing the switch to close its contacts. (*See illustration below and on page 7-12.*)

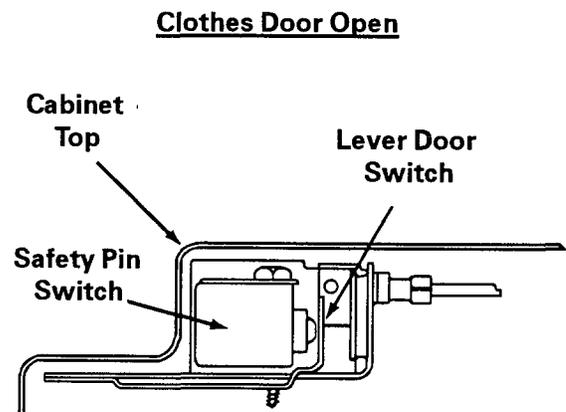

Clothes Door Closed

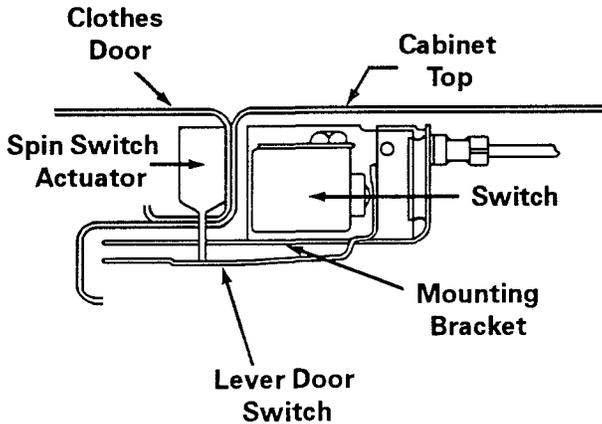

The safety spin switch controls the motor circuit during all spin cycles. When the clothes door is opened during a spin cycle, the motor is de-energized which allows the brake to engage, and brings the spinning basket to an immediate stop.

Testing Safety Spin Switch

The safety spin switch can be accessed by raising the top and opening the clothes door. It can be tested by using an ohmmeter and performing the following:

1. Disconnect the unit from the power source.
2. Remove the two (2) screws securing the safety switch assembly to the underside of the top.

3. Remove switch wiring.
4. Place test leads across the terminals at each end of switch. The switch contacts should be open, and continuity **SHOULD NOT** be indicated.
5. Leave the test leads across the terminals and depress the switch button. The switch contacts should close and continuity **SHOULD** be indicated.

SAFETY NOTE

When the clothes door is opened, the safety spin switch should open the circuit before the door is raised 2 inches.

If the switch circuit is not interrupted before the door is raised 2 inches, it is imperative that the reason for the malfunction be found and corrected.

THE SAFETY SPIN SWITCH IS OBVIOUSLY A SAFETY FEATURE AND SHOULD NEVER BE DEFEATED OR BYPASSED.

SECTION 8. SCHEMATIC DIAGRAM

SCHEMATIC DIAGRAM

A schematic diagram has been placed on the control panel of each unit. It can be accessed by removing the control panel shield located on the rear of the control panel.

The schematic diagram provides vital information needed to check a circuit and pinpoint a malfunctioning electrical component.

The schematic diagram contains the following:

- *Connection Diagram*
- *Ladder Wiring Diagram*

- *Cycle Sequence Chart*
- *Rear Board Connector Terminal Identification*
- *Motor Schematics*

A thorough understanding of the information available on the schematic diagram is a prerequisite for quick and accurate troubleshooting.

The *following illustrations, page 8-2 through 8-5*, depicts typical schematic diagrams for the Electronically Controlled Washer.

MODEL JW1000 WIRING DIAGRAM & ELECTRICAL SCHEMATIC

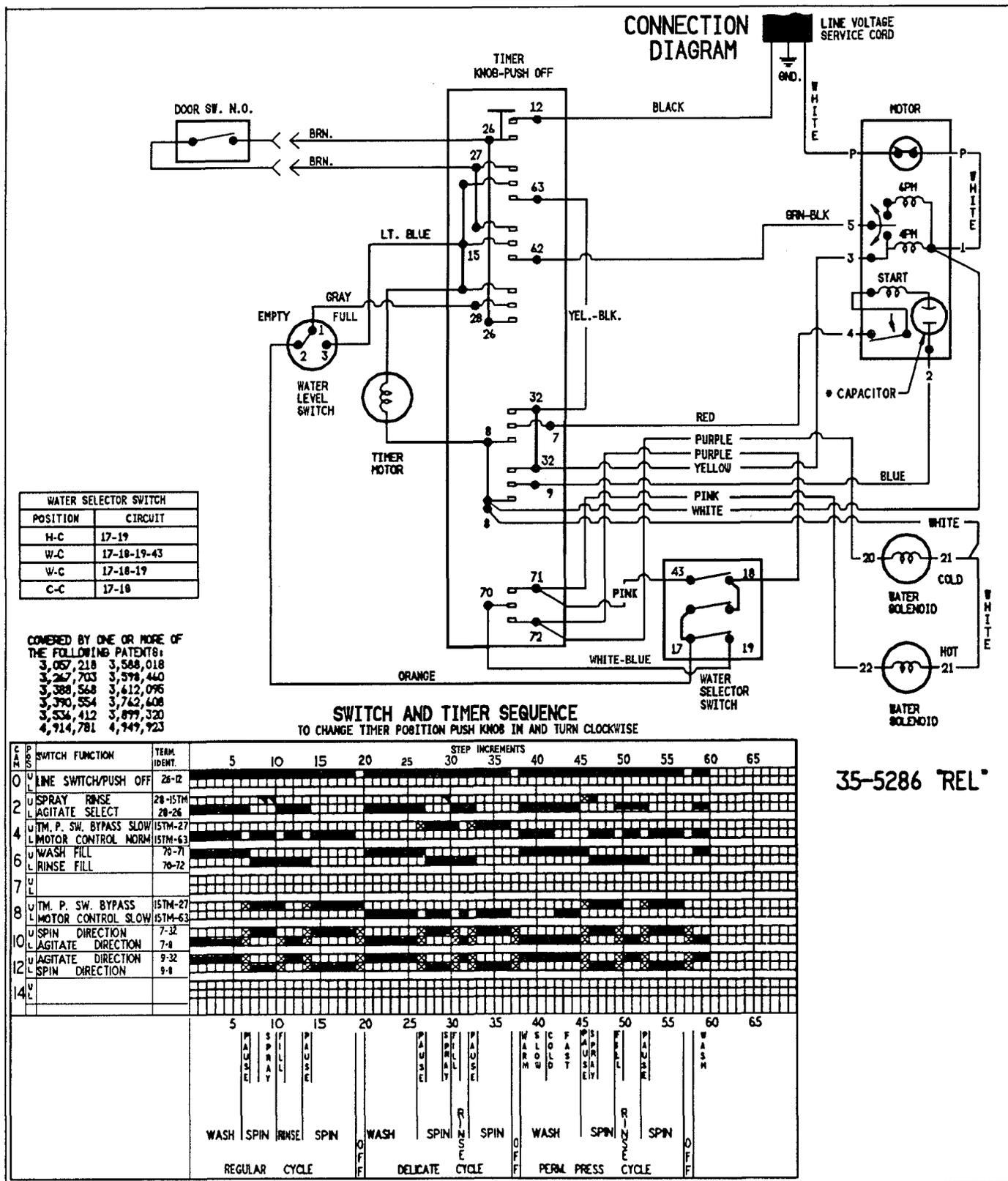

MODEL JW1000 WIRING DIAGRAM & ELECTRICAL SCHEMATIC CONT'D.

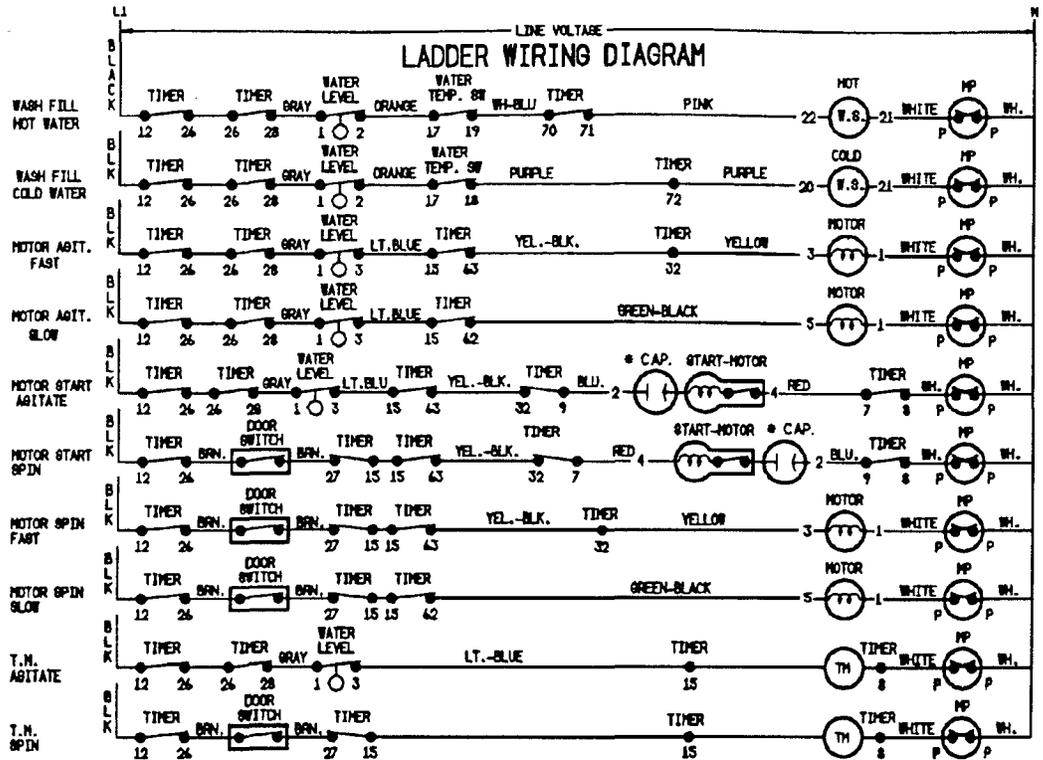

* CAPACITOR USED WITH ALTERNATE CAPACITOR START MOTOR.

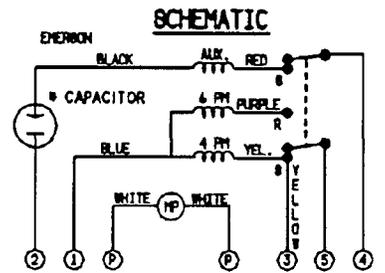
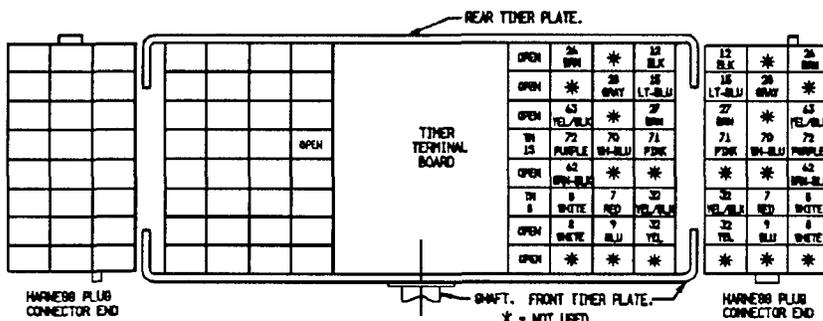

**DISCONNECT POWER BEFORE SERVICING
CAUTION: KEEP CLEAR OF SPINNING POWER UNIT**

MODEL JW2000 WIRING DIAGRAM & ELECTRICAL SCHEMATIC

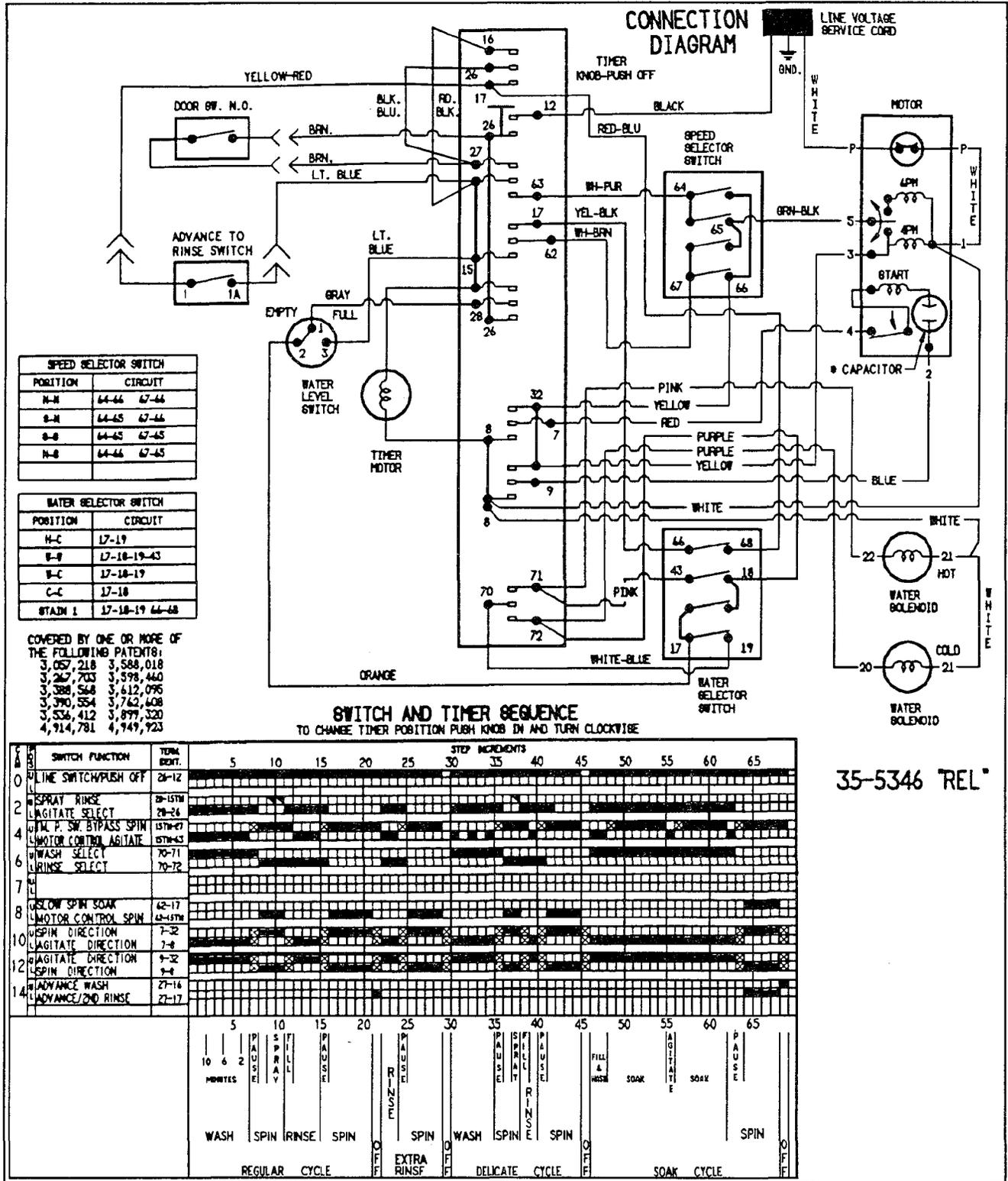

MODEL JW2000 WIRING DIAGRAM & ELECTRICAL SCHEMATIC CONT'D.

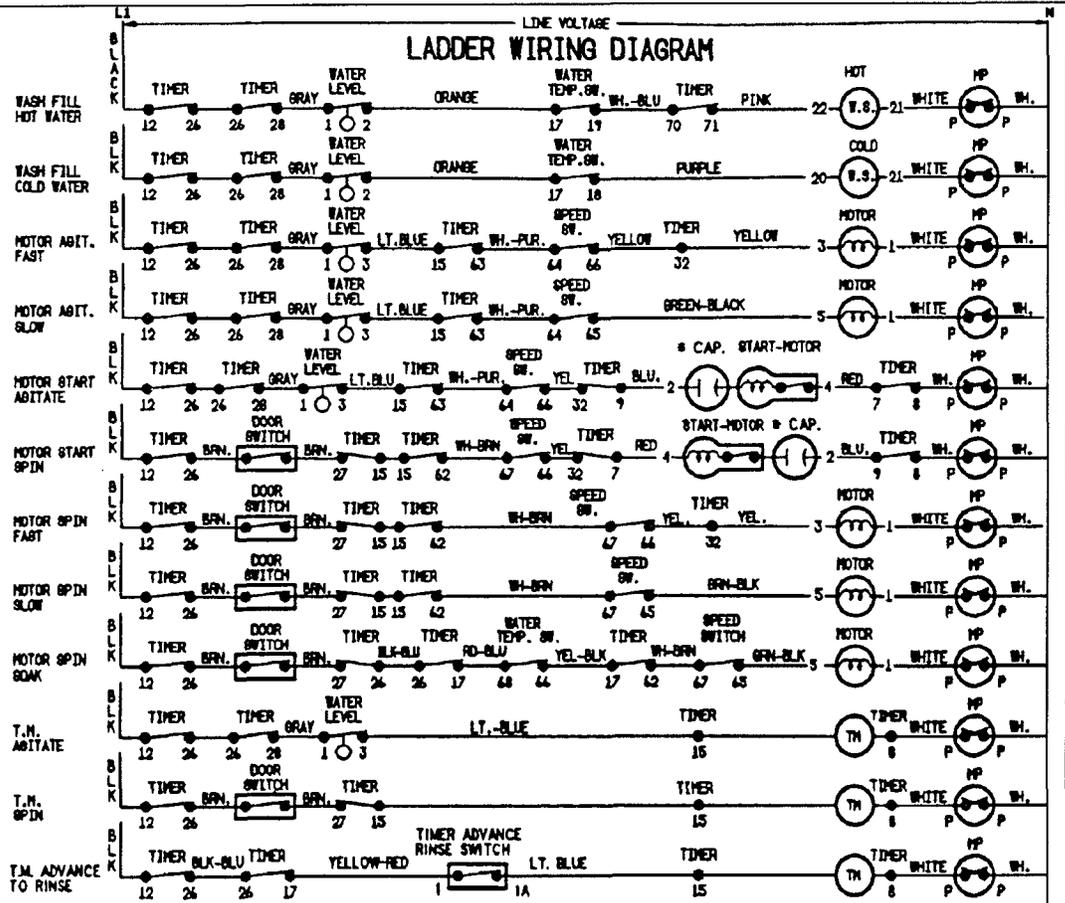

* CAPACITOR USED WITH ALTERNATE CAPACITOR START MOTOR.

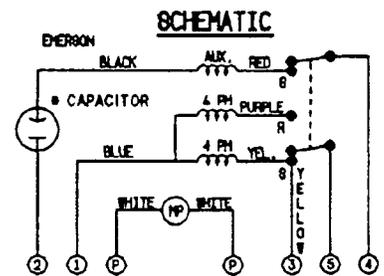
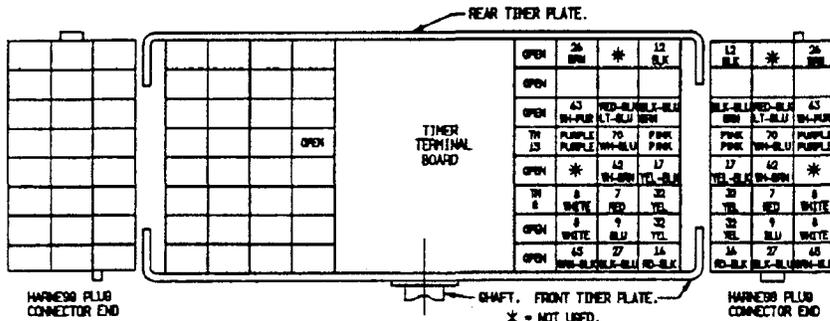

DISCONNECT POWER BEFORE SERVICING
CAUTION: KEEP CLEAR OF SPINNING POWER UNIT

SECTION 9. TROUBLESHOOTING

| QUICK CHECK SERVICE GUIDE | |
|----------------------------------|------------------------|
| SERVICE PROBLEM | QUICK CHECK NO. |
| Basket Revolves During Agitation | 3 |
| Clothes Wet After Spin | 8 |
| Excessive Vibration | 6 |
| Fills - Will Not Agitate | 2 |
| Fill Water Temperature Incorrect | 1 |
| No Timer Advance | 4 |
| Machine Does Not Shut Off | 4 |
| No Rinse Fill | 1 |
| Noisy In Spin | 6 |
| Noisy In Agitation | 6 |
| Spin Speed Too Slow | 5 |
| Water Leaks | 9 |
| Will Not Fill | 1 |
| Will Not Pump Out | 7 |
| Will Not Spin | 5 |

QUICK CHECK 1 - FILL WATER TEMPERATURE INCORRECT; NO RINSE FILL; WILL NOT FILL

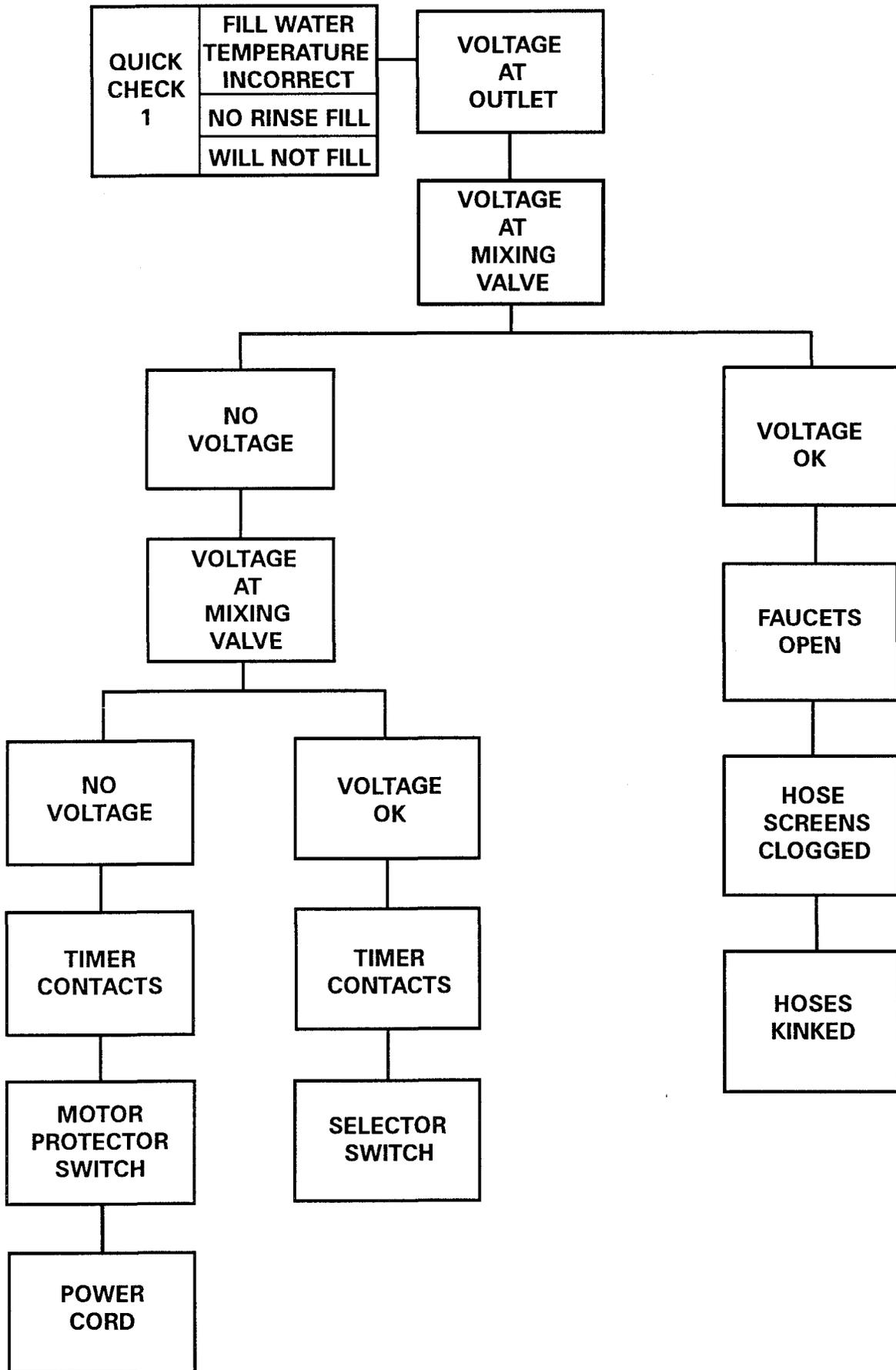

QUICK CHECK 2 - FILLS - WILL NOT AGITATE

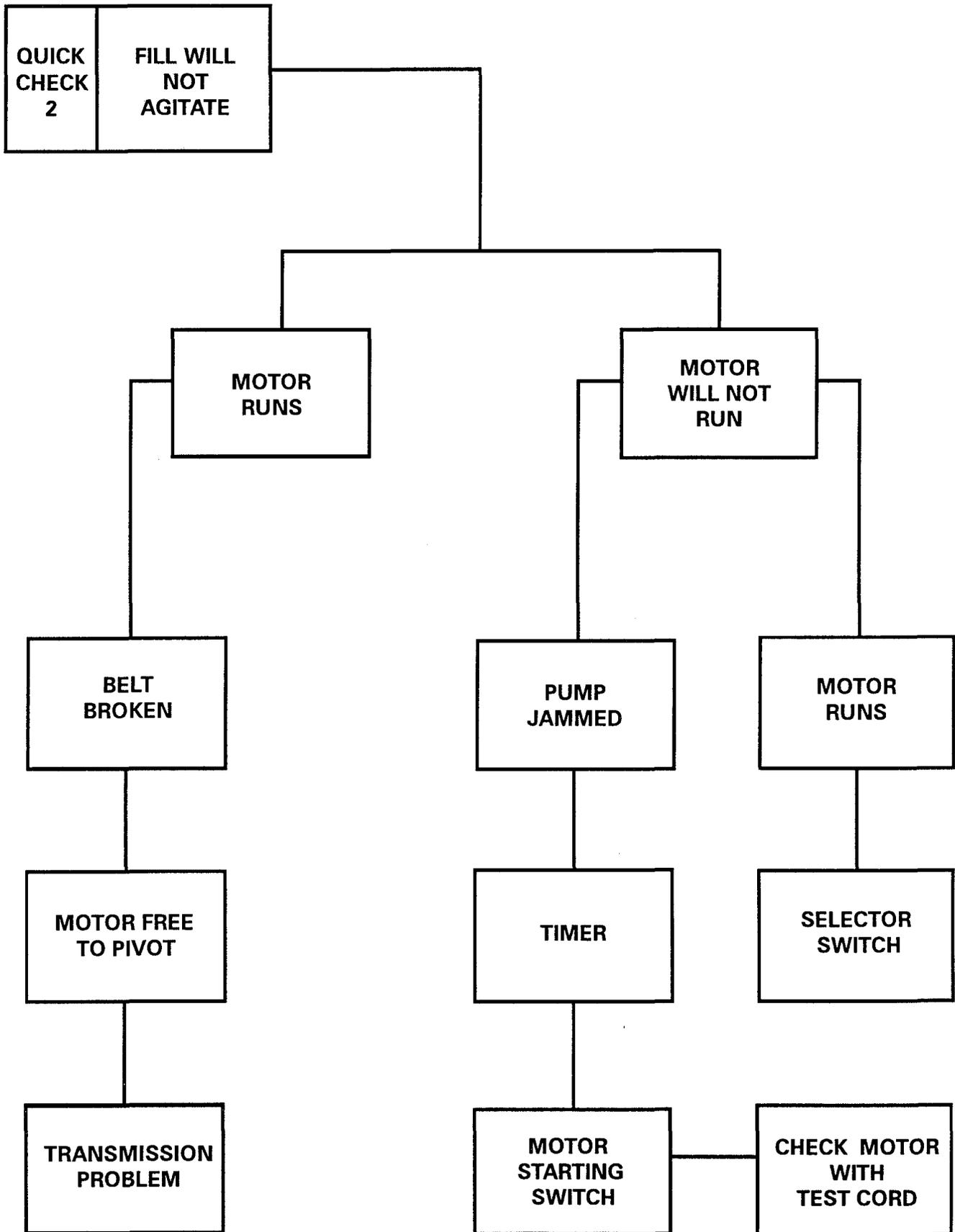

QUICK CHECK 3 - BASKET REVOLVES DURING AGITATION

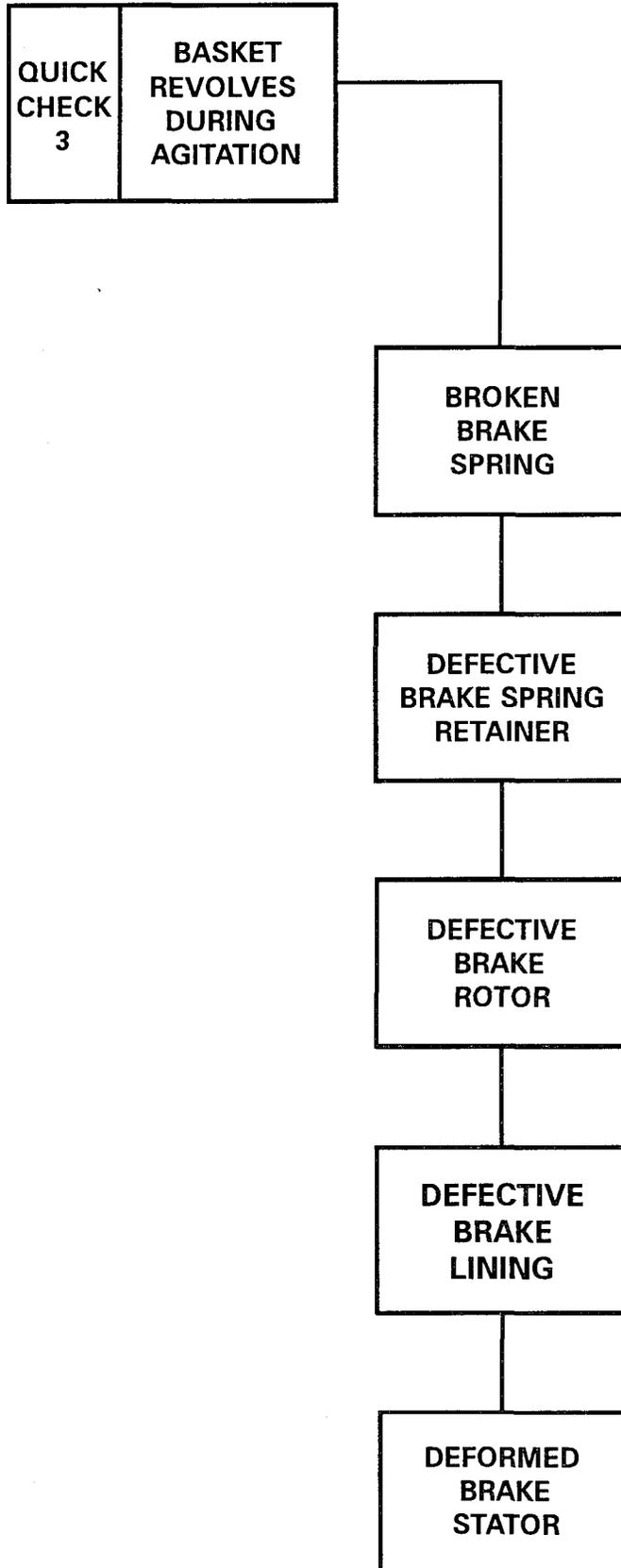

QUICK CHECK 4 - NO TIMER ADVANCE; MACHINE DOES NOT SHUT OFF

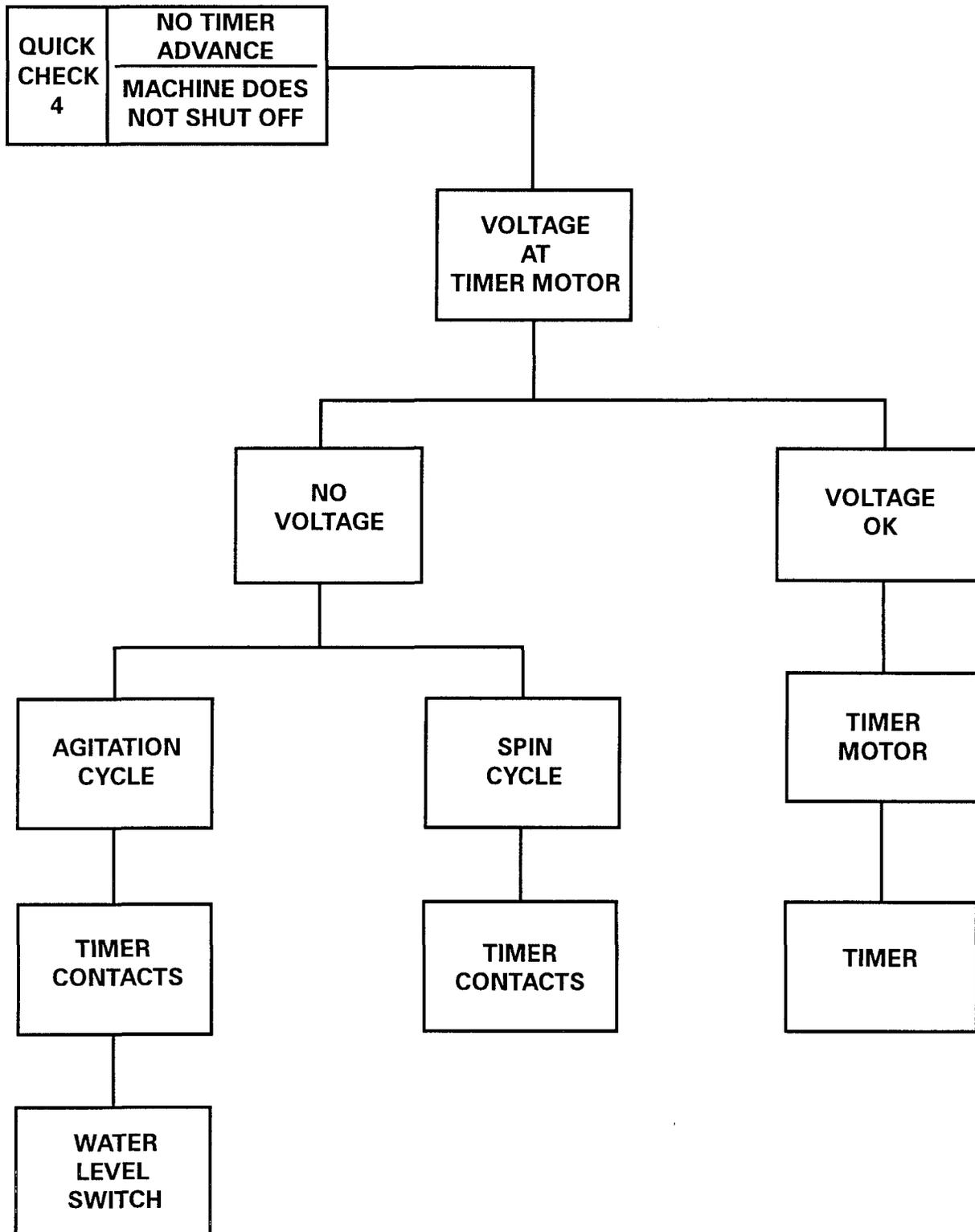

QUICK CHECK 5 - SPIN SPEED TOO SLOW; WILL NOT SPIN

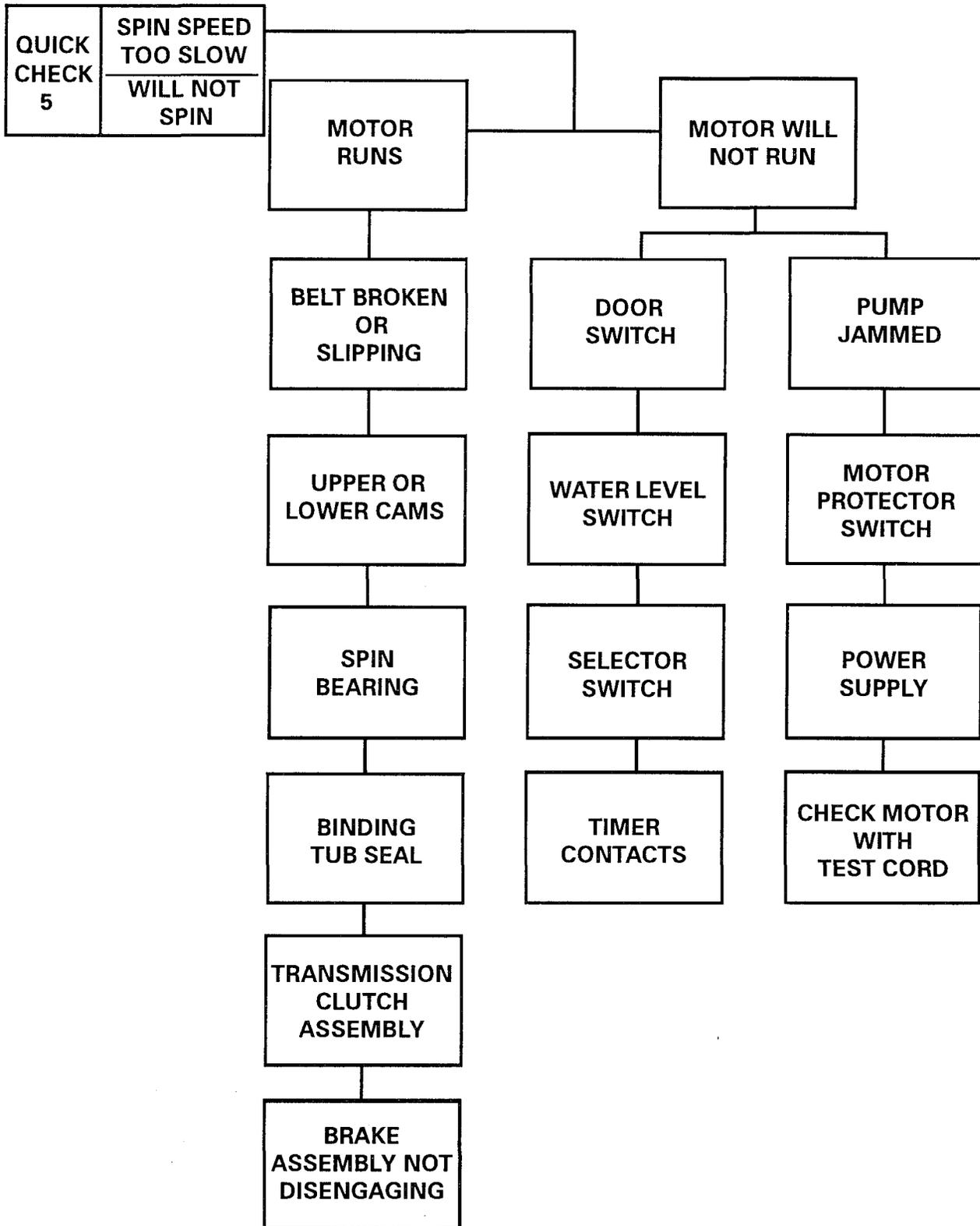

QUICK CHECK 6 - EXCESSIVE VIBRATION, NOISY IN SPIN, NOISY IN AGITATION

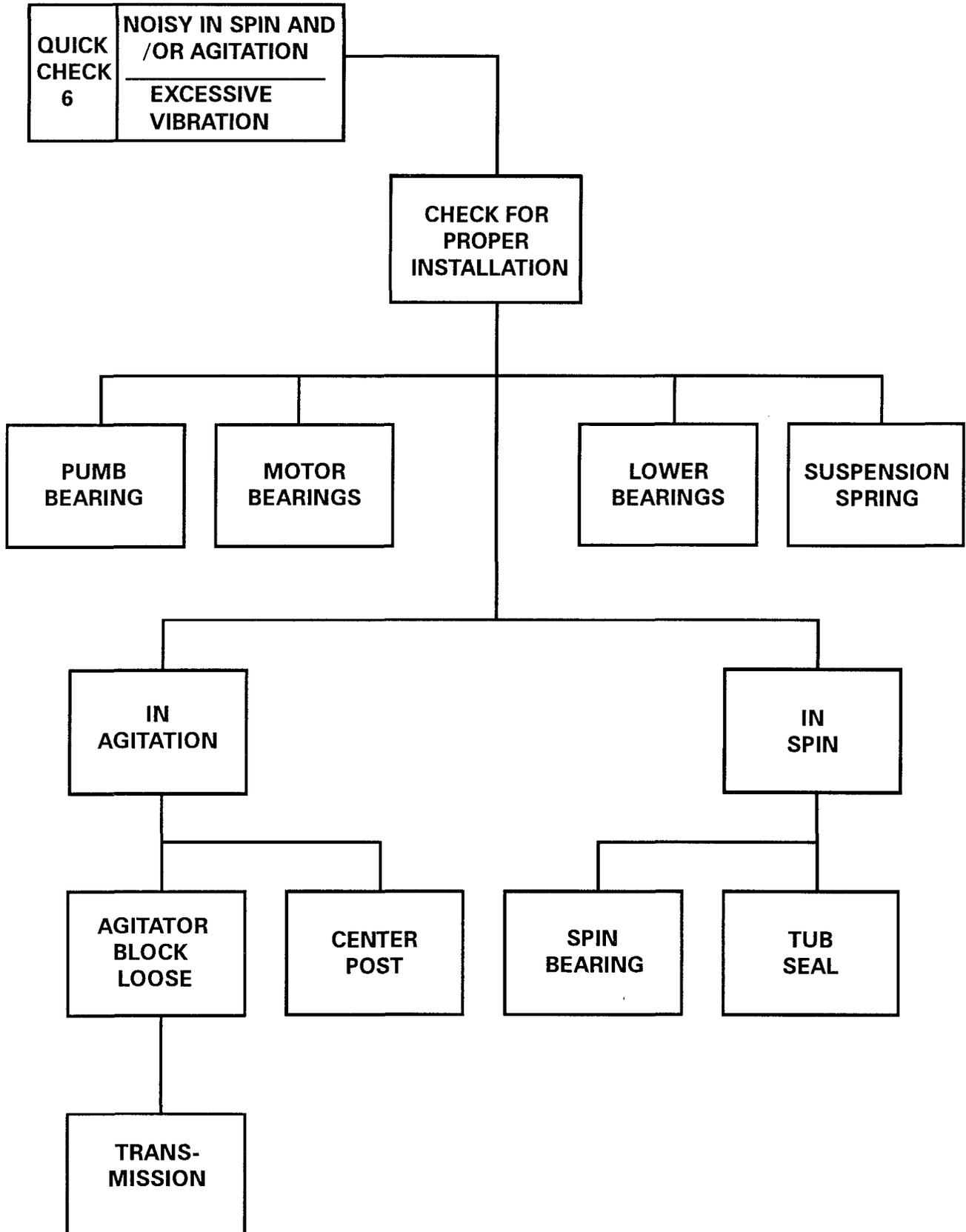

QUICK CHECK 7 - WILL NOT PUMP OUT

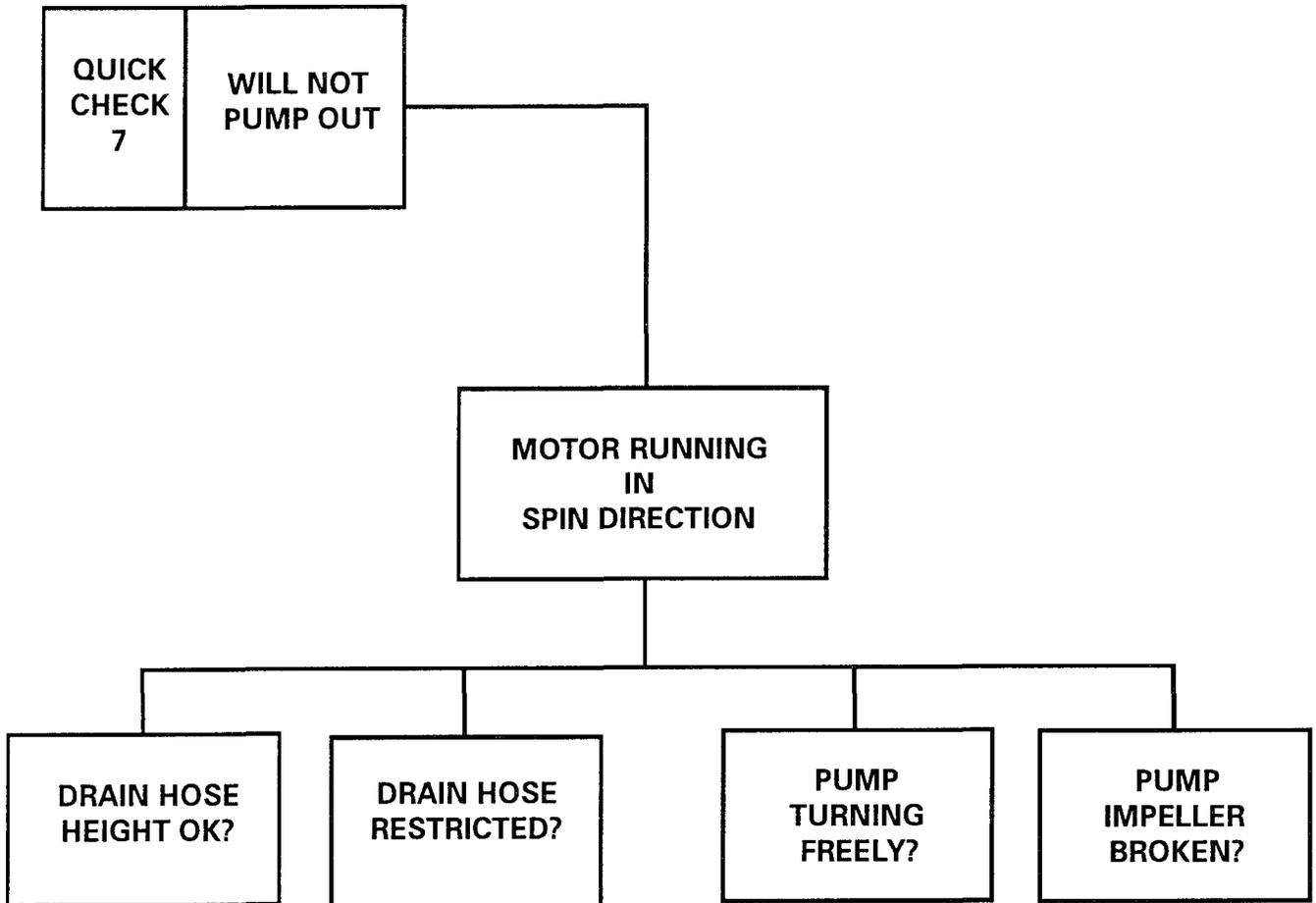

QUICK CHECK 8 - CLOTHES WET AFTER SPIN

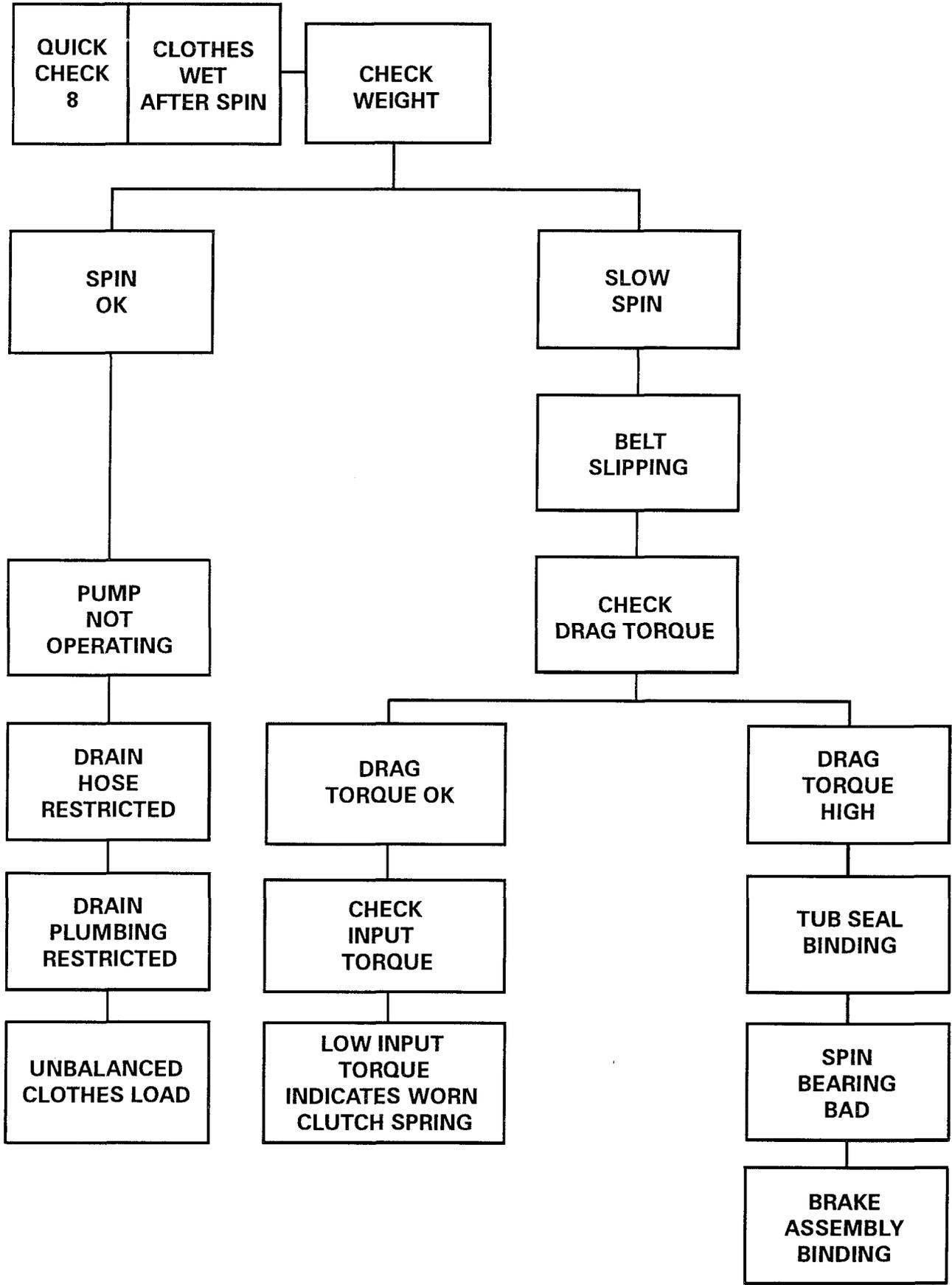

QUICK CHECK 9 - WATER LEAK

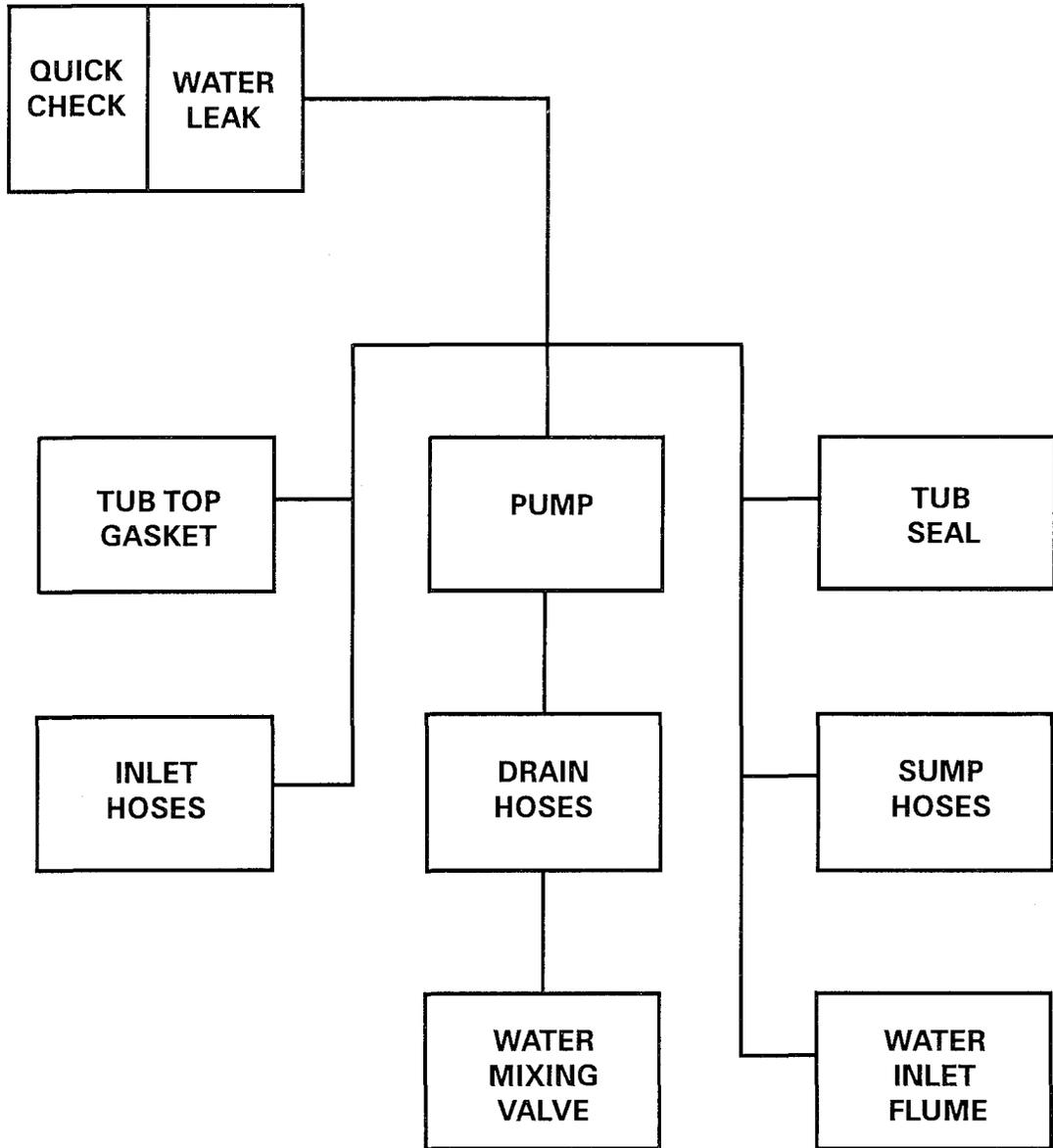

SECTION 10. ELECTRONIC CONTROL MODEL

This section details only the components and service procedures that are unique to the Electronic Control Washer. Therefore, it must be used in conjunction with the remainder of the service manual to provide a complete service program for these models.

OPERATING INSTRUCTIONS

- 1. LOAD BLEACH DISPENSER** - if desired (maximum one cup).
- 2. MEASURE DETERGENT** - place in washer basket.
- 3. LOAD CLOTHES** - loosely in washer. Maximum load is to top vanes of agitator.
- 4. LOAD LIQUID DISPENSER** - if desired. Fabric softener with regular cycles or liquid detergent with **STAIN-CLEANER** cycles. Clean between uses.
- 5. CLOSE LID**
- 6. PUSH START** - This activates the washer and allows time for you to make selections.
- 7. SELECT CYCLE** - The permanent press cycle has been pre-selected. This means that regular agitation/slow spin speeds, warm wash/cold rinse, and super water level lights will glow. If **START** is pressed, the washer will proceed through the **Permanent Press** cycle. If this is not the cycle desired, choose cycle

which best describes the type of fabric to be washed. Then press cycle chosen. The proper wash and spin speeds as well as the water temperature are automatically provided and indicated. If different speeds, water level or temperature is desired, use **Manual Options**. Indicator lights will glow when selection is made. The washer will beep when selections cannot be made.

- 8. WATER LEVEL - PRESET OR SUPER**
To change, touch **LEVEL** until desired setting is shown. Determine setting based on load size (*see table below*). Selection should provide sufficient water to permit clothes to circulate during agitation.

It may become necessary, due to bulky fabrics, to adjust the water level after agitation begins. To adjust for higher water level in wash, touch **OFF** then reactivate unit and make new selection. (**Steps 6 thru 9**). If higher or lower water level is desired only in rinse, touch **LEVEL** until desired water level is selected. Machine will automatically go to that level for rinse.

| Water Saver Control Setting | Dry Weight of Clothes (Per Pound) | (Kilograms) |
|-----------------------------|-----------------------------------|--------------|
| Super | 12 - 22 | (5.4 to 10) |
| High | 6 - 12 | (2.7 to 5.4) |
| Medium | 2 - 6 | (0.9 to 2.7) |
| Low | 2 or Under | (0.9) |

- 9. TO START - PUSH START/PAUSE**
You may stop the washer at any time. Push **PAUSE** to remain in the

cycle and **START** to resume. Push **OFF** to turn off the washer.

10. **STOPS AUTOMATICALLY** - When wash cycle is completed.

CYCLE DESCRIPTION

WHITES AND COLORS - Provides 15 minutes of regular agitation and a fast final spin. **WHITE** is preset on wash/cold rinse and high water level. **COLOR** is preset to give a warm wash/cold rinse and high water level.

PERMANENT PRESS - Preset to provide warm wash/cold rinse and 12 minutes of regular agitation. Slow spin speeds and three spray rinses help reduce wrinkling.

MIXED LOADS - Provides cold wash and rinse temperatures, 12 minutes of gentle agitation, and slow spin speeds.

FINE WASH - Provides 10 minutes of intermittent gentle agitation and a slow spin speed. Cold wash and rinse have been preset.

KNITS AND BLANKETS - Washer fills with warm water and agitates gentle for 10 minutes, followed by a cold rinse. Then a fast spin speeds remove excess moisture.

MANUAL OPTIONS:

The **Automatic Cycles** may be changed by using the **Manual Options** (Speed, Temperature, and Level). Select options at the beginning of the cycle. If one is overlooked, press **PAUSE** and make selection while washer is in **FILL**. Indicator lights illuminate option selected. Some combinations of **Automatic Cycles**

and **Manual Options** also vary time. Washer will beep if a selection cannot be made.

ULTRA WASH CYCLES:

Eliminate the need for pre-spot products while providing comparable stain removal performance. Add liquid or granular detergent (step 2), then place liquid detergent in the liquid dispenser (step 4). Clothes soak for 30 minutes with several brief minutes of agitation. Water is spun out and clean wash water is added along with liquid detergent for a 15 minute wash.

ULTRA WASH I - Provides a hot water soak and wash with a cold rinse.

ULTRA WASH II - Provides a warm water soak and wash with a cold water rinse. As in **ULTRA WASH I**, water and detergent are refreshed.

SOAK-TO-WASH - Eliminates the inconvenience of wash tub soaking of stained clothes before the wash cycle. **SOAK-TO-WASH** provides a 15 minute soak which automatically proceeds into a 15 minute wash without pump out of wash water. Brief periods of agitation are used to thoroughly dissolve detergent.

QUICK WASH - Reduces wash time of any cycle except **ULTRA WASH** by 50% with no effect on rinse or spin times.

EXTRA RINSE - Adds an additional rinse fill, 4 minutes of agitation, and 5 minutes of spin. The agitation and spin speeds correspond to cycle selected.

SPIN ONLY - Washer will drain and spin for 5 minutes at fast spin speed. Use for draining washer after cancelling a cycle or after a power failure. It can also be

used to spin water from a hand washed item. **SPIN ONLY** can be selected at any time during a cycle. Washer can be turned **OFF** during **SPIN ONLY**, but **PAUSE** will not be accepted.

electro-mechanical timer or selector switches. Instead, it is equipped with solid state components which control these functions electronically.

CONTROL SHIELD AND ELECTRONIC ASSEMBLY

The *Electronic Control Washer* differs from the conventional washer as it has no

These solid state components are pre-assembled to the control panel shield, and other than the water level switch and light assembly, will be serviced as a complete assembly. (See illustration.)

CONTROL PANEL

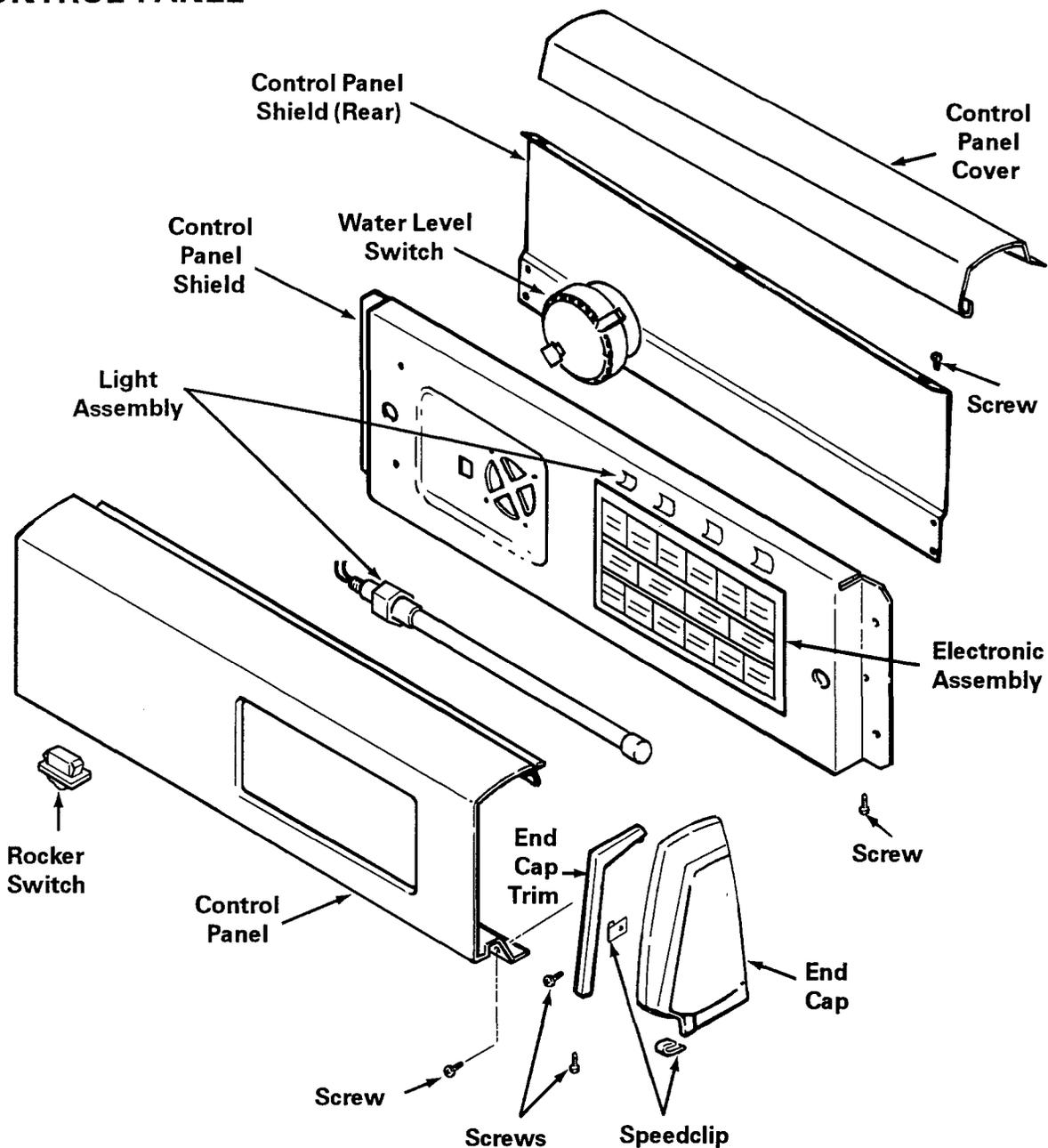

The **Control Shield** and **Electronic Assembly** consists of the following components. (See *Illustration on page 10-5.*)

- **Control Shield** - Basically the same as the conventional one, but has been designed to mount the electronic controls.
- **Electronic Control Package** - Operates on line voltage and consists of two (2) circuit boards that have been tab locked to the rear of the control shield. The smaller of the circuit boards contains the rear board connector which receives the machine wiring harness plug.
- **Membrane Switch** - A large mylar rectangle containing the programming graphics for the unit. It adheres to the front of the control shield.
- **Speaker Assembly** - Attaches to the control shield rear with four (4) screws.
- **Light Assembly** - Attaches to the control panel with four (4) clips.

CONTROL PANEL DISASSEMBLY

Before attempting to gain access to the controls mounted within the control panel assembly, place a protective cloth or pad on the cabinet top in front of the control panel, to protect both the top and the membrane switch.

1. **Disconnect the unit from the power source** unless troubleshooting the electronic control.
2. Remove the three (3) screws which secure the rear top edge of the control panel to the end caps. Lift off hood.
3. Remove the two (2) screws which secure the bottom front corners of the control panel to the end caps and lift off the control panel.
4. Remove the screws which attach the Control Shield and Electronic Assembly to the end caps and lay the front of the assembly on the protective cloth. The electronic control and water level switch are now accessible for testing and/or replacement.

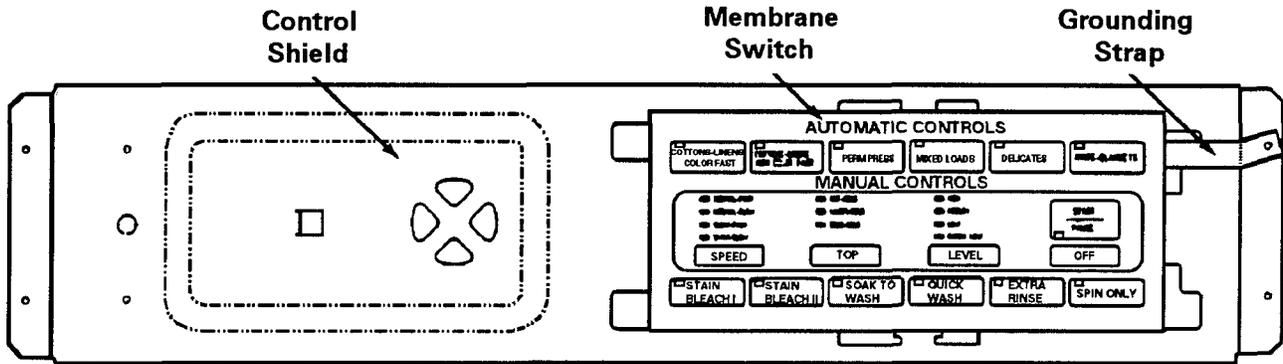

Control Shield And Electronic Assembly (Front)

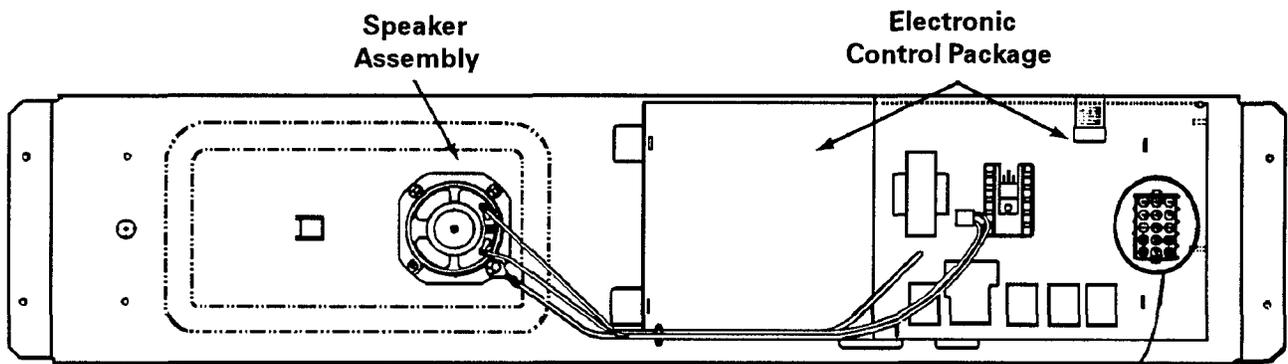

Control Shield And Electronic Assembly (Rear)

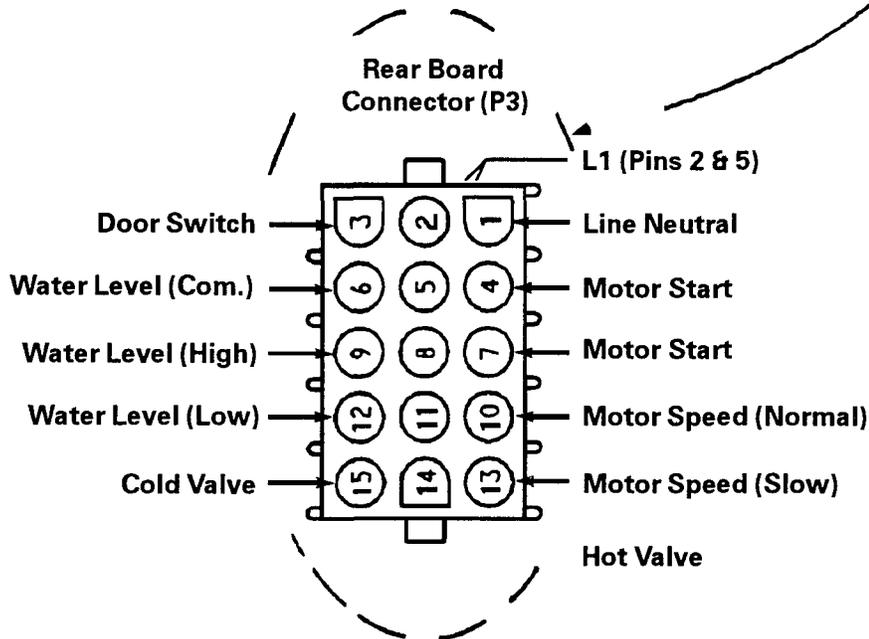

SCHEMATIC DIAGRAM

A schematic diagram has been placed inside the control panel of each unit. It can be accessed by removing the control panel shield located on the rear of the control panel. The schematic diagram provides vital information needed to check out a circuit and pinpoint a malfunctioning electrical component.

The schematic diagram contains the following:

- ***Connection Diagram***
- ***Ladder Wiring Diagram***
- ***Cycle Sequence Chart***
- ***Rear Board Connector Terminal Identification***
- ***Motor Schematics***

A thorough understanding of the information available on the schematic diagram is a prerequisite for quick and accurate troubleshooting.

The *illustration on page 10-7* depicts a typical schematic diagram for the ***Electronic Control Washer***.

MODEL JW3000 WIRING DIAGRAM & ELECTRICAL SCHEMATIC

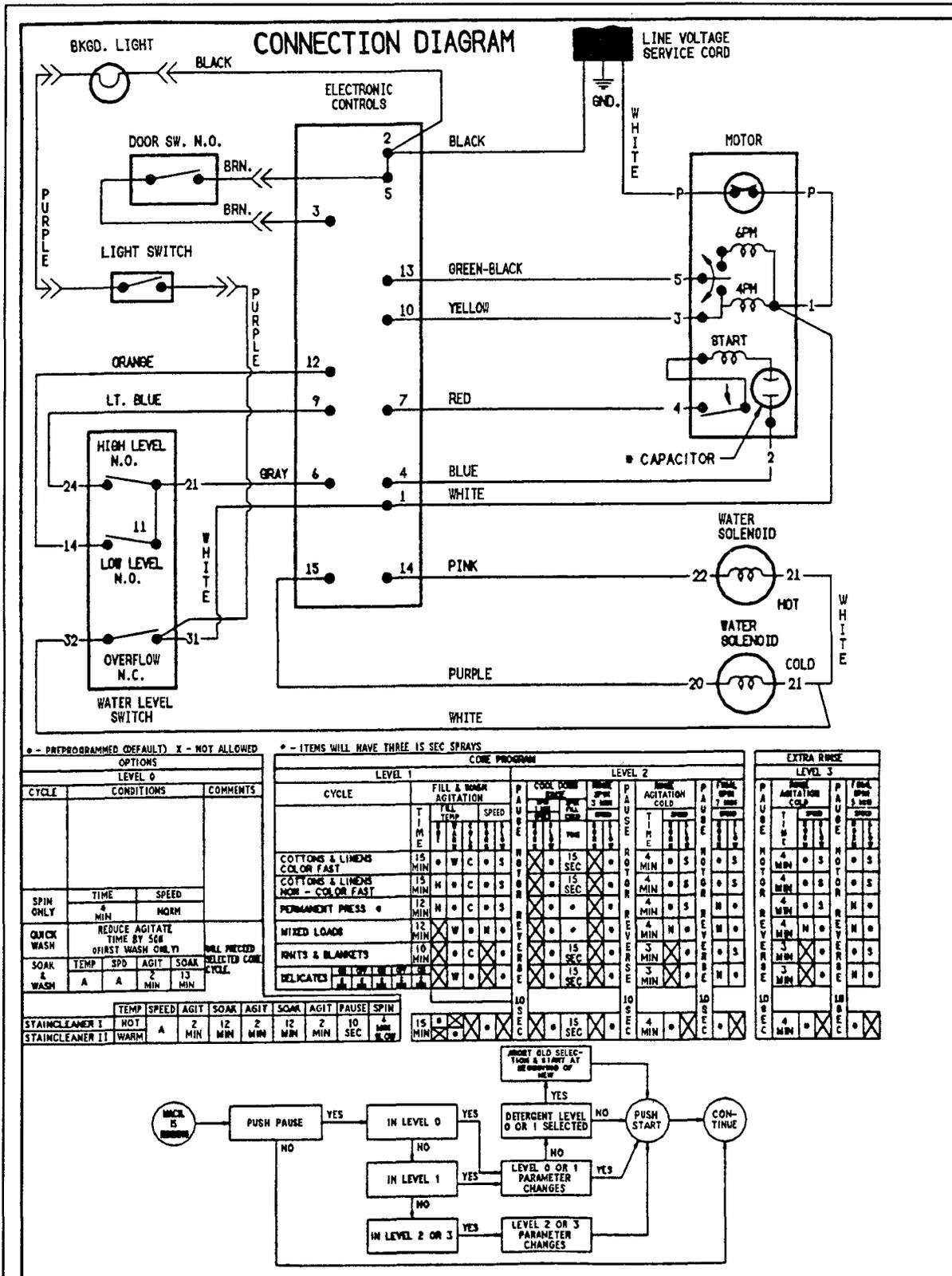

MODEL JW3000 WIRING DIAGRAM & ELECTRICAL SCHEMATIC CONT'D.

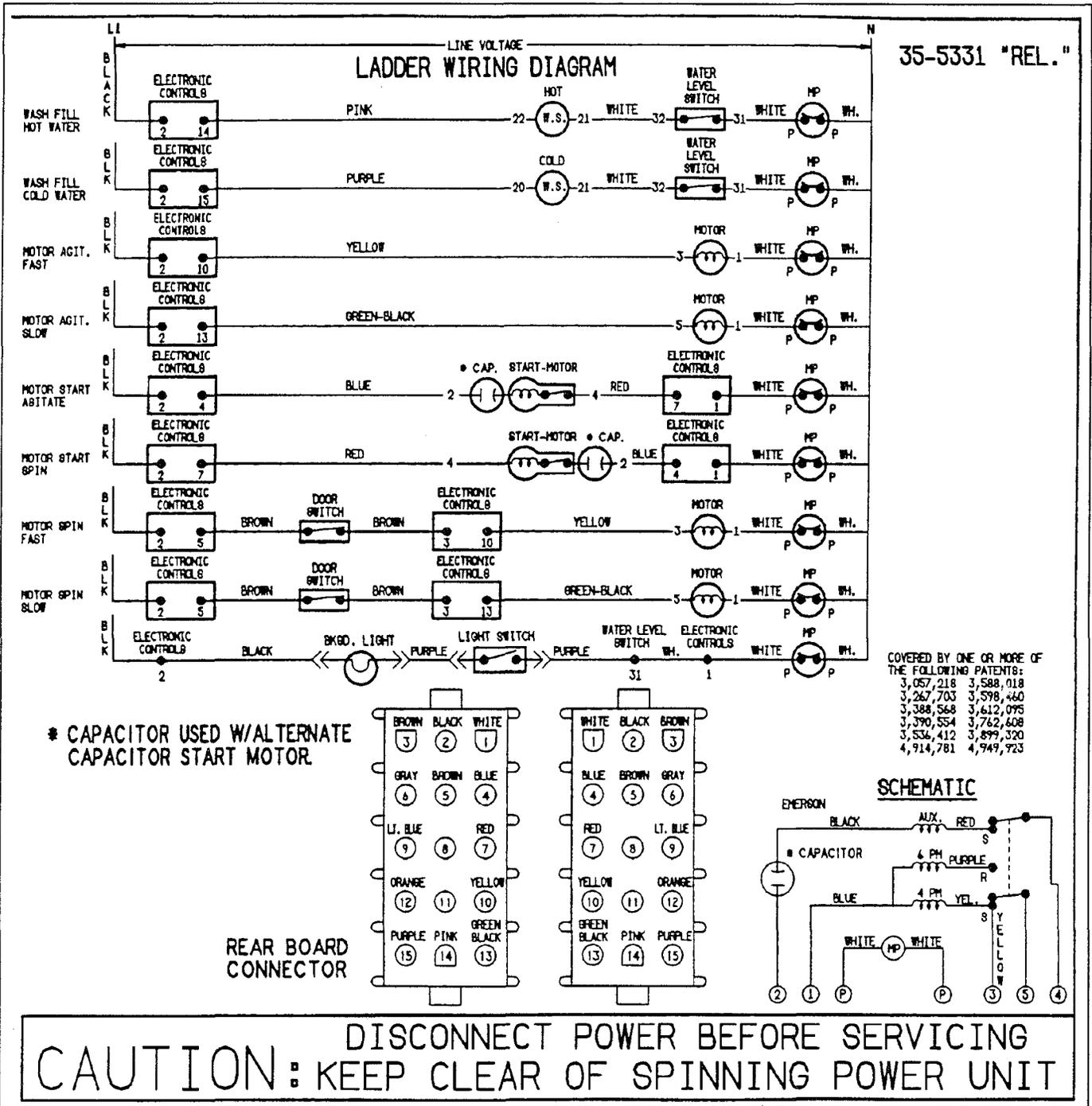

TESTING THE ELECTRONIC CONTROLS

To test the electronic control, turn the unit on and allow it to proceed to the point of failure. Follow the control panel disassembly instructions, as previously detailed, to access the electronic control for testing. Leave the wiring harness plugged into the rear board connector.

A voltmeter can now be used at the rear of the wiring harness plug, in combination with the washer schematic, to confirm proper circuitry through the electronic control.

EXAMPLE

To test the electronic control on a unit that will not fill with hot water, the initial step will be to place the voltmeter leads between wire terminal #2 and wire terminal #4. If the circuit is closed, there is nothing wrong with the electronic control.

If the circuit is not closed, leads placed between wire terminal #1 and wire terminal #2 (L1) should verify a closed circuit and confirm power to the electronic control.

After verification, leads placed between wire terminal #1 and wire terminal #14 (hot valve) should also show a closed circuit if the electronic control is functioning properly.

NOTE: *Terminal identification at the rear of the wiring harness plug is made easier by using the three (3) flat sided terminal holes for orientation.*

IMPORTANT

Because of the complexity of the electronic control package, no attempt should be made to service it in the field. Instead, should an electronic control be *diagnosed as malfunctioning, replace the Control Shield and Electronic Assembly as a unit.*

WATER LEVEL SWITCH

The water level switch on the Electronic Control Washer is snap locked to the control shield, beside the speaker assembly.

The water level switch is operated by a column of air that becomes trapped in the pressure switch hose. This hose is connected between the diaphragm section of the switch and the air bell, which is located on the lower portion of the tub. As water enters the tub, a small amount enters the pressure switch hose trapping air in the hose. As the water level increases in the tub, the column of air becomes compressed and exerts pressure on the water level switch diaphragm. When the proper water level is reached, the diaphragm actuates single pole, double throw switches in the water level switch assembly.

The water level switch is quite sensitive and requires very little air pressure to activate it at the maximum fill position. Therefore, it is most important that the hose connections to the switch diaphragm and air bell nipple be airtight, as the smallest air leak will cause erratic operation.

IMPORTANT

The water level switch is adjusted at the manufacturing source and *no adjustments should be made in the field.*

Whenever the hose is removed from the water level switch or the air bell nipple, **DO NOT** reconnect the hose until all water has been drained from the tub. To assure proper operation of the water level switch, the hose must not have any water in it when reinstalled on the switch. When reconnecting the hose, be sure to slip it over the nipple(s) as far as possible and always replace the hose clamp(s).

WATER LEVEL SWITCH OPERATION

The water level switch used on the Electronic Control Washer consists of the following internal switches:

- **Low** - Contacts 11-14, normally open.
- **Super** - Contacts 21-24, normally open.
- **Overflow** - Contacts 31-32, normally closed.

These switches are used in conjunction with the electronic control to provide all the featured water level settings. These settings are accomplished as follows:

- **Low Setting** - Contacts 11-14 close.
- **Medium Setting** - Contacts 11-14 close and the electronic control calculates additional time for the mixing valve circuit to stay closed.
- **High Setting** - Contacts 11-14 close and the electronic control calculates still more additional time for the mixing valve circuit to stay closed.
- **Super Setting** - Contacts 21-24 close.

The normally closed overflow switch has been placed in the fill circuit for safety reasons. If an overflow condition arises, the switch will open which also opens the fill circuit and shuts off the water.

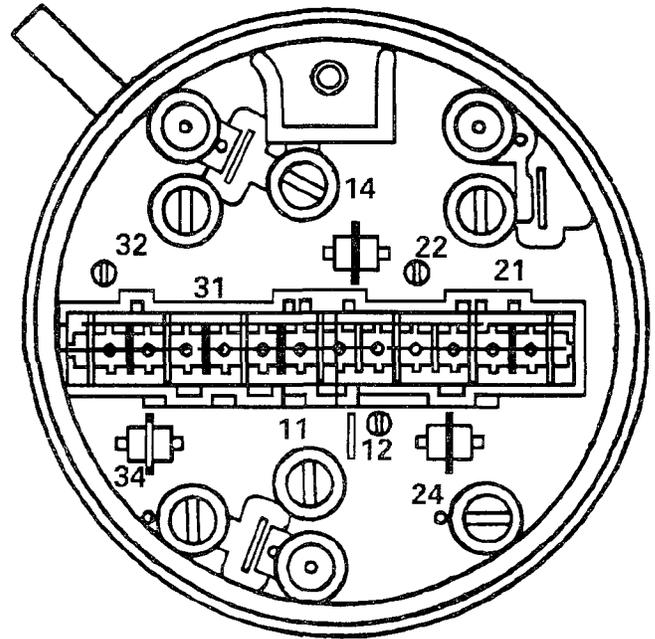

Water Level Switch (Rear View)

The water level switch can be accessed as previously detailed under **Control Panel Disassembly**.

WATER LEVEL SWITCH TESTING:

The water level switch can be tested using an ohmmeter and executing the following:

- Overflow terminals 31-32 should always indicate continuity.
- When the tub is empty, ohmmeter leads placed across terminals 11-14 should not indicate continuity.
- When the tub is filled, as per the switch setting **Low, Medium, or High**, contacts 11-14 should indicate continuity, but contacts 21-24 should not. When the tub is filled to the **Super** setting, contacts 11-14 and contacts 21-24 should indicate continuity.

MAYTAG

Customer Service
240 Edwards St.
Cleveland, TN 37311