

Service

This manual is to be used by qualified appliance technicians only. Maytag does not assume any responsibility for property damage or personal injury for improper service procedures done by an unqualified person.

Compact Washer

This Base Manual covers general information
Refer to individual Technical Sheet
for information on specific models

This manual includes, but is
not limited to the following:

MAH2400AW*

Important Information

Important Notices for Technicians and Consumers

Maytag will not be responsible for personal injury or property damage from improper service procedures. Pride and workmanship go into every product to provide our customers with quality products. It is possible, however, that during its lifetime a product may require service. Products should be serviced only by a qualified service technician who is familiar with the safety procedures required in the repair and who is equipped with the proper tools, parts, testing instruments and the appropriate service information. **IT IS THE TECHNICIANS RESPONSIBILITY TO REVIEW ALL APPROPRIATE SERVICE INFORMATION BEFORE BEGINNING REPAIRS.**

 WARNING
To avoid risk of severe personal injury or death, disconnect power before working/servicing on appliance to avoid electrical shock.

To locate an authorized technician, please consult your telephone book or the dealer from whom you purchased this product. For further assistance, please contact:

Customer Service Support Center

CAIR Center

Web Site

Telephone Number

WWW.MAYTAG.COM 1-800-688-9900

CAIR Center in Canada 1-800-688-2002

Recognize Safety Symbols, Words, and Labels

 DANGER

DANGER—Immediate hazards which **WILL** result in severe personal injury or death.

 WARNING
--

WARNING—Hazards or unsafe practices which **COULD** result in severe personal injury or death.

 CAUTION
--

CAUTION—Hazards or unsafe practices which **COULD** result in minor personal injury, product or property damage.

Table of Contents

Important Information	2
Important Safety Information	4
General Information	
Model Identification	8
Serial Label Location	8
Model Nomenclature	9
Model Specifications	10
Troubleshooting	
Troubleshooting General Symptoms	11
Disassembly Procedures	
Top Removal	16
Water Valve Removal	16
Pressure Valve Removal	16
Drain Pump Removal	17
EMI Filter Removal	18
Console/Machine Control Board Removal	18
Boot Removal	19
Door Assembly Removal	19
Disassemble Door	20
Front Panel/ Door Latch Removal	20
Motor and Belt Removal	21
Tub Pulley Removal	22
Tub Removal	22
Appendix A	
Installation Instructions	27
Appendix B	
Use And Care	36

Important Safety Information



WARNING

To reduce the risk of fire, electric shock, serious injury or death to persons when using your washer, follow these basic precautions:

- Read all instructions before using the washer.
- Refer to the Grounding Instructions in the Installation Manual for the proper grounding of the washer.
- Do not wash articles that have been previously cleaned in, washed in, soaked in, or spotted with gasoline, dry-cleaning solvents, or other flammable or explosive substances as they give off vapors that could ignite or explode.
- Do not add gasoline, dry-cleaning solvents, or other flammable or explosive substances to the wash water. These substances give off vapors that could ignite or explode.
- Under certain conditions, hydrogen gas may be produced in a hot water system that has not been used for two weeks or more. Hydrogen gas is explosive. If the hot water system has not been used for such a period, before using a washing machine or combination washer-dryer, turn on all hot water faucets and let the water flow from each for several minutes. This will release any accumulated hydrogen gas. The gas is flammable, do not smoke or use an open flame during this time.
- Do not allow children to play on or in the washer. Close supervision of children is necessary when the washer is used near children. This is a safety rule for all appliances.
- Before the washer is removed from service or discarded, remove the lid to the washing compartment.
- Do not reach into the washer if the wash tub is moving.
- Do not install or store the washer where it will be exposed to water and/or weather.
- Do not tamper with the controls.
- Do not repair or replace any part of the washer, or attempt any servicing unless specifically recommended in the User-Maintenance instructions or in published user-repair instructions that you understand and have the skills to carry out.
- To reduce the risk of an electric shock or fire, do not use an extension cord or an adapter to connect the washer to the electrical power source.
- Use your washer only for its intended purpose, washing clothes.
- Always disconnect the washer from electrical supply before attempting any service. Disconnect the power cord by grasping the plug, not the cord.
- Install the washer according to the Installation Instructions. All connections for water, drain, electrical power and grounding must comply with local codes and be made by licensed personnel

when required. Do not do it yourself unless you know how!

- To reduce the risk of fire, clothes which have traces of any flammable substances such as vegetable oil, cooking oil, machine oil, flammable chemicals, thinner, etc. or anything containing wax or chemicals such as in mops and cleaning cloths, must not be put into the washer. These flammable substances may cause the fabric to catch on fire by itself.
- Do not use fabric softeners or products to eliminate static unless recommended by the manufacturer of the fabric softener or product.
- Keep your washer in good condition. Bumping or dropping the washer can damage safety features. If this occurs, have your washer checked by a qualified service person.
- Replace worn power cords and/or loose plugs.
- Be sure water connections have a shut-off valve and that fill hose connections are tight. Close the shut-off valves at the end of each wash day.
- Loading lid must be closed any time the washer is in operational fill, tumble, or spin. Do not attempt to bypass the loading lid switch by permitting the washer to operate with the loading lid open.
- Always read and follow manufacturer's instructions on packages of laundry and cleaning aids. Heed all warnings or precautions. To reduce the risk of poisoning or chemical burns, keep them out of the reach of children at all times (preferably in a locked cabinet).
- Always follow the fabric care instructions supplied by the garment manufacturer.
- Never operate the washer with any guards and/or panels removed.
- Do not operate the washer with missing or broken parts.
- Do not bypass any safety devices.
- Failure to install, maintain, and/or operate this washer according to the manufacturer's instructions may result in conditions which can produce bodily injury and/or property damage.

NOTE: The Warnings and Important Safety Instructions appearing in this manual are not meant to cover all possible conditions and situations that may occur. Common sense, caution and care must be exercised when installing, maintaining, or operating the washer.

Always contact your dealer, distributor, service agent or the manufacturer about any problems or conditions you do not understand.

Important Safety Information

WARNING

To avoid personal injury or death from improper servicing, make sure you read and understand the descriptions and meaning of various safety symbols, words and labels used in this manual, before attempting any procedures described in the manual. Failure to understand and comply with safety information may result in severe personal injury or death.

General Information

This Service Manual describes the operation, disassembly, troubleshooting, and repair of the Compact washer. It is intended for use by authorized technicians who troubleshoot and repair these units.

NOTE: It is assumed that users of this manual are familiar with the use of tools and equipment used to troubleshoot and repair electrical, and mechanical systems; and understand the terminology used to describe and discuss them.

Related Publications

This is a base service manual, covering a range of similar models. It is intended to be used in conjunction with the Parts Manual and Technical Sheet covering the specific model being serviced.

Electrical Service Information

Proper Grounding and Polarization of 120 Volts Wall Outlets

For the safety of our customers and the Service Technician ALL appliances have a three-prong power cord and **MUST** be connected to a properly polarized AND grounded wall outlet.

This information was written for those who do not understand grounding and polarization of a wall outlet. A 120 volt wall outlet must always be wired as shown below.

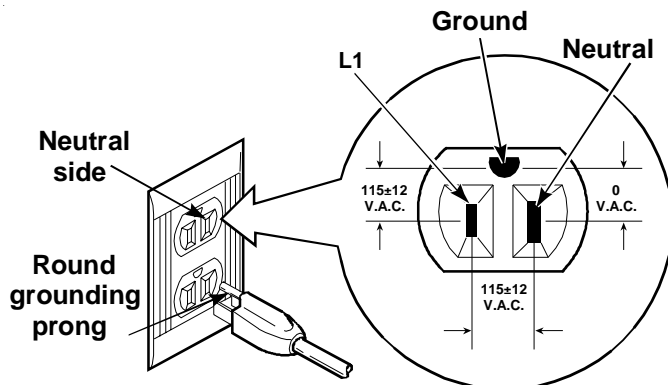

About Ground Wires

In the event of an electrical short circuit, a ground wire reduces the risk of electric shock by providing an escape wire for the electric current.

Standard accepted color coding for ground wires is **green** or **green with a yellow stripe**.

Grounding wires and wires colored like grounding wires are **NOT** to be used as current carrying conductors.

WARNING

To reduce the risk of fire, electric shock, serious injury or death, all wiring and grounding must conform with the latest edition of the National Electric Code, ANSI/NFPA 70, or the Canadian Electrical Code, CSA C22.1, and such local regulations as might apply. It is the customer's responsibility to have the wiring and fuses checked by a qualified electrician to make sure your home has adequate electrical power to operate the washer.

WARNING

To avoid risk of personal injury or death due to electrical shock:

- **Observe all local codes and ordinances.**
- Disconnect electrical power to unit before servicing.
- Ground appliance properly.
- Check with a qualified electrician if you are not sure this appliance is properly grounded.
- DO NOT ground to gas line.
- DO NOT ground to cold water pipe if pipe is interrupted by plastic, nonmetallic gaskets, or other insulating (nonconducting) materials.
- DO NOT modify plug on power cord. If plug does not fit electrical outlet, have proper outlet installed by qualified electrician.
- DO NOT have a fuse in the neutral or ground circuit. A fuse in the neutral or ground circuit could result in an electrical shock.
- DO NOT use an extension cord with this appliance.
- DO NOT use an adapter plug with this appliance.
- DO NOT pinch power cord.

Important Safety Information

Explanation

Polarization—This means that the larger slot must be neutral and the small slot must be at line voltage.

Mispolarized—The outlet is incorrectly wired so that the larger slot is at line voltage and the smaller slot is neutral.

Grounded—This means the round hole connection is connected to earth ground through a connection to the main power panel.

Ungrounded—The round hole connection is not complete to earth ground and/or the main power panel.

Grounding Instructions

WARNING

- To avoid the risk of electrical shock or death, do not alter the plug.
- Do not remove grounding prong when installing grounded appliance in a home that does not have three wire grounding receptacle. Under no condition is grounding prong to be cut off or removed. It is the personal responsibility of the consumer to contact a qualified electrician and have properly grounded three prong wall receptacle installed in accordance with appropriate electrical codes.
- To avoid the risk of electrical shock or death, this equipment must be grounded.

This equipment **MUST** be grounded. In the event of an electrical short circuit, grounding reduces the risk of electric shock by providing an escape wire for the electric current. This unit is equipped with a cord having a grounding wire with a grounding plug. The plug must be plugged into an outlet that is properly installed and grounded.

Consult a qualified electrician or technician if grounding instructions are not completely understood, or if doubt exists as to whether the equipment is properly grounded. Do not use an extension cord. If the product power cord is too short, have a qualified electrician install a three-slot receptacle. This unit should be plugged into a separate 60 hertz circuit with the electrical rating as shown in the appropriate drawing. Models operate with a supply voltage of 120 Volts.

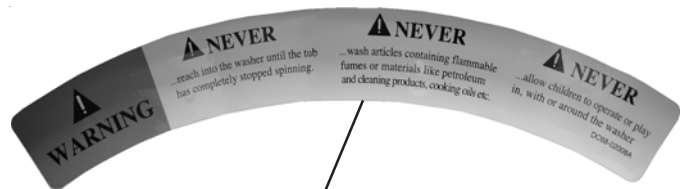

Important Safety Information

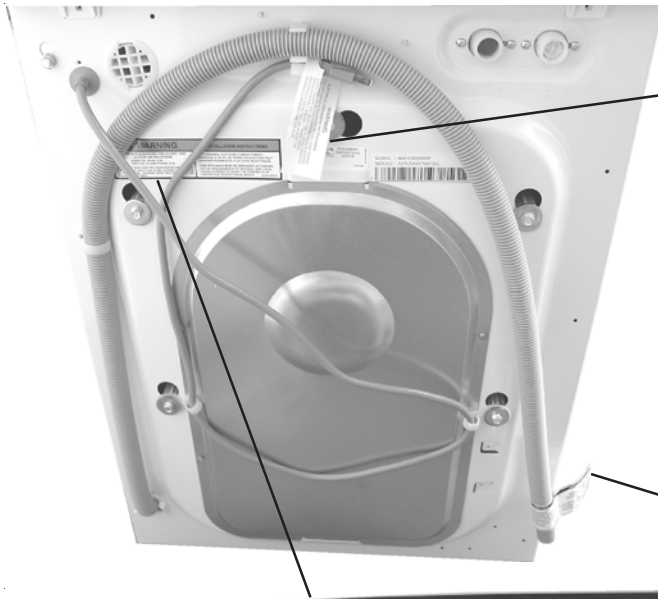

WARNING

ELECTRICAL GROUNDING INSTRUCTIONS

THIS APPLIANCE IS EQUIPPED WITH A THREE-PRONG (GROUNDING) PLUG FOR YOUR PROTECTION AGAINST SHOCK HAZARD AND SHOULD BE PLUGGED DIRECTLY INTO A PROPERLY GROUNDED THREE-PRONG RECEPTACLE. DO NOT CUT OR REMOVE THE GROUNDING PRONG FROM THIS PLUG.

WARNING

MINIMUM CLEARANCES FOR CLOSET AND ALCOVE INSTALLATIONS

SIDES 0 IN., REAR -0 IN.
TOP -0 IN., CLOSET FRONT -0 IN.

CLOSET FRONT MUST HAVE TWO UNOBSTRUCTED AIR OPENINGS COMBINED TOTAL AREA 72 SQ. IN. MIN. LOCATED 3 IN. MIN. FROM TOP AND BOTTOM. LOUVERED DOOR WITH EQUIVALENT AIR OPENING IS ACCEPTABLE.

DRAIN HOSE INSTALLATION: MAYTAG **IMPORTANT**

- If the standpipe is less than 36" high, the drain hose must be routed through clip on the cabinet back to raise hose to proper height.
- If an airtight connection between the drain hose and standpipe is demanded, an anti-siphon valve is needed.
- Do not remove the hose retainer from the drain hose.

CLIP

HOSE RETAINER

DC68-02045A



WARNING

CONTROL BOARD, HEAT SINK, MOTOR AND PUMP ARE INTENTIONALLY NOT GROUNDED AND MAY PRESENT A RISK OF ELECTRIC SHOCK, ONLY DURING SERVICING.

CAUTION

KEEP CLEAR
ROTATING BELTS AND PULLEYS

DC68-02003A

DC68-02006A

General Information

Model Identification

Complete registration card and promptly return. If registration card is missing:

- For Maytag product call 1-800-688-9900 or visit the Web Site at www.maytag.com
- For product in Canada call 1-866-587-2002 or visit the Web Site at www.maytag.com.

When contacting provide product information located on rating label. Record the following:

Model Number: _____
Manufacturing Number: _____
Serial or S/N Number: _____
Date of purchase: _____
Dealer's name and address: _____



Serial Label is located in the Lower side of the door opening and back panel.



Service

Keep a copy of sales receipt for future reference or in case warranty service is required. To locate an authorized technician:

- For Maytag call 1-800-462-9824 or visit the Web Site at www.maytag.com.
- For product in Canada call 1-866-587-2002 or visit the Web Site at www.maytag.com.

Warranty service must be performed by an authorized technician. We also recommend contacting an authorized technician, if service is required after warranty expires.

Parts and Accessories

Purchase replacement parts and accessories over the phone. To order accessories for your product call:

- For Maytag product call 1-800-462-9824 or visit the Web Site at www.maytag.com.
- For product in Canada call 1-866-587-2002 or visit the Web Site at www.maytag.com.

Extended Service Plan

We offer long-term service protection for this new washer.

- Dependability Plus™ Extended Service Plan is specially designed to supplement Maytag's strong warranty. This plan covers parts, labor, and travel charges.
Call 1-800-925-2020 for information.

General Information

Compact Washer Nomenclature

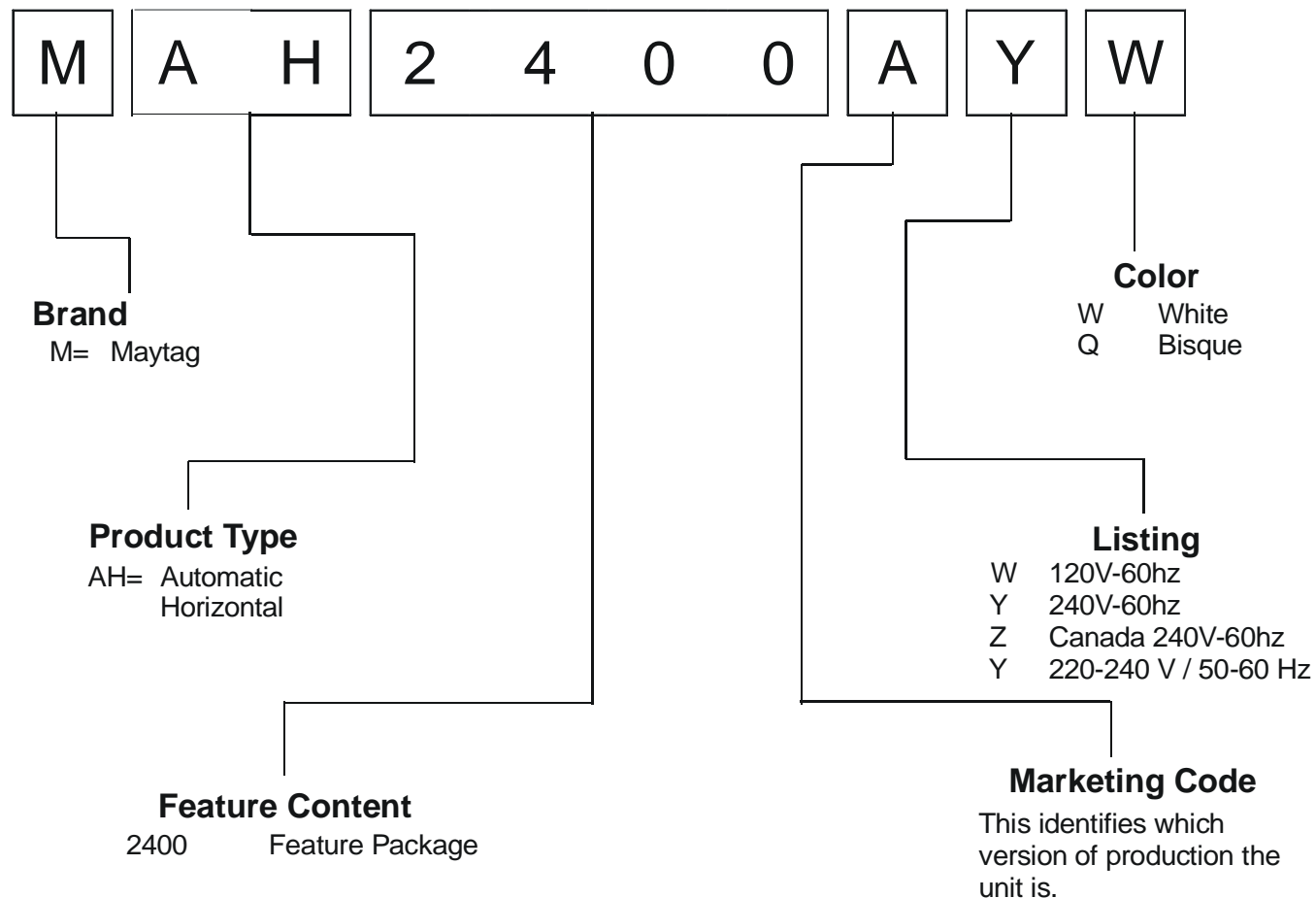

Trouble Shooting and Diagnostic Guide is Located Behind Toe Panel.

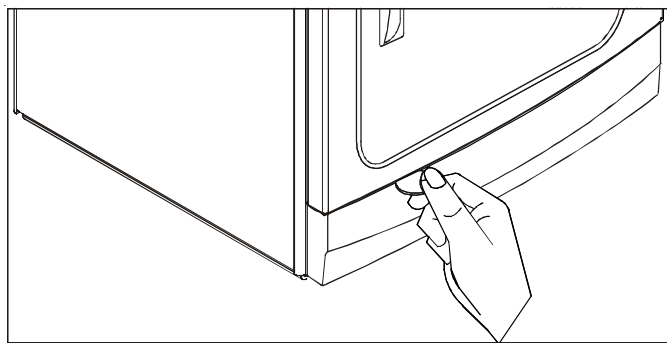

General Information

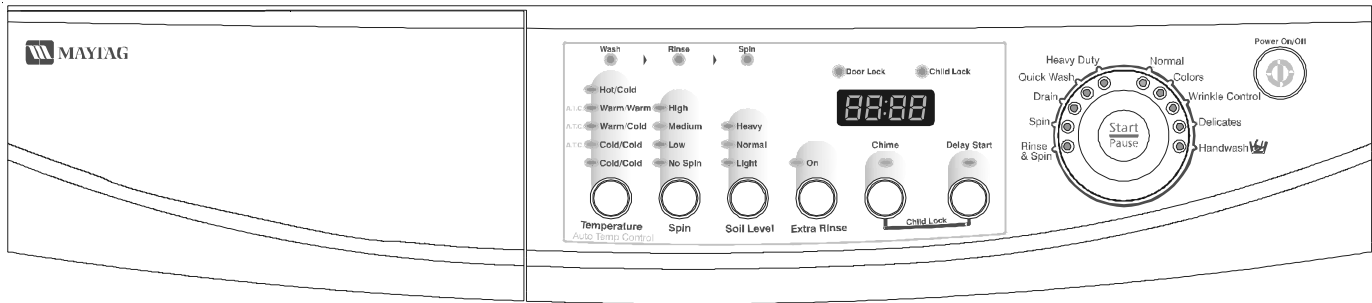

FEATURES	MAH2400AWW
Controls	LED
Time Remaining Indicator	•
Start/Pause Pad	•
Washtub	Stainless Steel
Capacity	2.4 Cu.Ft.
Baffles	3
Speed Combinations	Infinite
TumbleClean™ Wash System	•
Speed/Fabric Program	
Normal Wash Cycle	•
Wrinkle Control Cycle	•
Delicates Wash Cycle	•
Handwash Cycle	•
Rinse & Spin Cycle	•
Quick Wash Cycle	•
Heavy Duty Wash Cycle	•
Delay Start Option	19 Hours
Extra Rinse Option	•
End-of-Cycle Chime	On/Off
Child Lock Option	•
Water Level Control	IntelliFill™
Water Temperature Combinations	5
ATC (Energy Star®)	Cold = 65°/ Warm = 105°
Soil Level Selections	Heavy/Normal/Light
Automatic Detergent Dispenser	Timed
Automatic Bleach Dispenser	Timed
Automatic Fabric Softener Dispenser	Timed
Self Cleaning Lint Removal	System
Suspension	2 Springs
Top	Laminate
Cabinet	Tri-Coat
Spin Speeds	
High	1200
Medium	800
Low	600
No Spin	0
Colors	W
DIMENSIONS	
Width	23.75 in.
Height	33.5 in.
Depth	25.2 in.
Depth With Door Open 90°	41.25 in.

Troubleshooting Procedures



WARNING

To avoid risk of electrical shock, personal injury or death, disconnect power to unit before servicing, unless testing requires power.

Place washer into Service Mode and check for diagnostic codes. See Technical Data Sheet behind Toe Panel.

Will Not Start

- Plug cord into live electrical outlet. Check for proper voltage.
- Check fuse or reset circuit breaker.
- Push the START/PAUSE button to start the clothes washer.
- Close door and push the START/PAUSE button to start the clothes washer. START/PAUSE LED should change from flashing to on continuously.
- Check to see if the washer in a pause or soak period in the cycle. Wait briefly and it may start.
- Check for restricted drain system.
- Check the line filter connection terminals for good connections.
- Check the Machine Control Board terminal connections. See Technical Sheet or Mini Manual packed inside washer.
- Check for stuck buttons on Console, pushing in on board tact switches. Readjust buttons on inside of Console.
- Replace Console Control Board.

Leaking

- Make sure inlet hose connections are not leaking. Check for rubber gasket damage due to over-tightening.
- Check standpipe for leak. Wrap a dry rag around the standpipe opening. If rag becomes wet, leak is fault of home plumbing. Be sure the standpipe is capable of accepting the flow of water from the washer.
- Make sure end of drain hose is correctly inserted and secured to drain standpipe.
- Check internal hose connections (fill, drain systems, dispenser hoses & clamps).
- Check rubber boot. Remove, reposition and reinstall, if necessary.
- Check for possible kinked dispenser to outer tub hose. Hot water pressurization may force door open.

No Tumble

- Start normal cycle with an empty machine and allow a fill to check tumble.
- Fabric cycles such as NORMAL, DELICATES, HAND WASH, & WRINKLE CONTROL only tumble periodically, every 60 seconds.
- Washer does not tumble during most fills or during presoak.
- Perform **Board Output Test**. See Technical Sheet or Mini Manual packed behind Toe Panel.
- Check for loose connections at Machine Control Board, Pressure Switch, Motor, Tach Harness and Motor Control.
- Check motor windings resistance. (Connector CN1 Pins 8 & 9 = 3.6 ohms, pins 1 & 10 = 1.1 ohms, Pins 5 & 10 = 1.1 ohms)
- Check belt.
- Washer with heat option does not tumble while heating. (Export washers only)

Will Not Spin

- Check to make sure the door is fully closed.
- Check for water left inside the washer. If present, see **Will Not Drain**.

- Perform **Board Output Test**. See Technical Sheet or Mini Manual packed behind Toe Panel. Will washer spin? Possible unbalanced load scenario previously.
- Check for loose connections at Machine Control Board, Pressure Switch, Motor, Tach Harness and Motor Control.
- Check belt.

No Water Fill

- Test water fill. Perform **Board Output Test**. See Technical Sheet or Mini Manual packed behind Toe Panel.
- Check to make sure water supply is turned on fully.
- With no clothes in washer normal water level is between the 4th and 5th hole on the spinner back wall.
- Check electrical circuit and connections at the Water Valve, and Pressure Switch.
- Check for kinks in inlet hoses.
- Check for clogged inlet screens.
- Visually check hot and cold separately for fill.
- Check for low water pressure. May be dependent on pressure entering home. Variations may occur due to usage in the home at the time machine is used.
- Check for frozen pipes and hoses.
- Check resistance of water valve coils. (Normal 1.18K ohms; CN3 connector – Cold (BU) – Bleach (OR) – Hot (RD) and the White wire pin 1 on main.
- Check for loose connections at the Pressure Switch or on the Machine Control Board, connector 5P.

Tub Full of Suds

- Check for restricted drain system. See **Will Not Drain** and **Will Not Spin**.
- Check for loose wire connections at Control Board and Drain Pump.
- Perform **Board Output Test**. See Technical Sheet or Mini Manual packed behind Toe Panel.
- Use high efficiency or low sudsing detergent specially formulated for front load washers.
- Reduce detergent amount for that specific load size and soil level. Towel loads have a minimal amount of soil present and typically create more suds.
- Check to see if belt is off motor and pulley.
- Run the clothes washer through another complete cycle using the coldest water, tablespoon of salt and no detergent.

Wet Clothes

- Very small clothes loads can cause unbalanced loads. Add additional towels.
- Excessive suds may have been present, due to not using High-efficiency detergent. Reduce amount of detergent usage.
- See **Will Not Spin**.
- Low Spin Speed was selected.

Will Not Lock

- Door not all the way closed or not properly aligned. Possible laundry load is too large to close door.
- Place washer into **Service Mode** and check for diagnostic codes 4 & 18. See Technical Sheet or Mini

Troubleshooting Procedures



WARNING

To avoid risk of electrical shock, personal injury or death, disconnect power to unit before servicing, unless testing requires power.

- Manual packed behind Toe Panel.
- Perform **Board Output Test**. Check door lock system. See Technical Sheet or Mini Manual packed behind Toe Panel.
- Check electrical connections at lock switch assembly and Machine Control Board (CN2).

Will Not Unlock

- Push door closed to make sure nothing from inside is pressing against it, which may keep it from unlocking.
- Display shows **LO**. Press **Off**, **Start/Pause** or unplug washer. Door will unlock after 3 minutes.
- Door locked from water level too high. Opening door will result in water draining from door opening.
- Place washer into **Service Mode**. See Technical Sheet or Mini Manual packed behind Toe Panel.
- Perform **Board Output Test**. See Technical Sheet or Mini Manual packed behind Toe Panel. Check door lock system for loose connections.

Will Not Drain

- Check for restricted drain system.
- In cold climates check for frozen drain hose.
- Check for 120 VAC at the Drain Pump when a spin cycle is selected.
- Check pump motor winding resistance. (14.2 ohms)
- Check that the machine control correctly senses the water level in the washer. See **Board Input Test**. See Technical Sheet or Mini Manual packed behind Toe Panel.
- Go to **Board Output Test** and perform Pump out test. See Technical Sheet or Mini Manual packed behind Toe Panel.
- Check the Machine Control Board connections at CN3 (Pin 1) for the pump and relay (Pin 2).
- Should see 110-120VAC.
- Check tub to pump hose for twist in hose.

Wrong Water Temperature

- Check that both faucets are turned on fully.
- Make sure water heater is set to deliver a minimum of 120°F (49°C) hot water at the tap. Also check water heater capacity and recovery rate.
- If the water heater is located a long distance from washer, the water line may need to be purged prior to starting wash cycle.

- Too Hot/Too Cold: This washer uses a reduced amount of water, while the control board meters the incoming flow to regulate the actual temperature of the water in the tub. This may appear to be significantly warmer/cooler than expected.
- Make sure the temperature selection is correct.
- Disconnect inlet hoses from the Water Valve and clean the valve screens of any debris.

Noisy and/or Vibration/Walking

- Check if the washer was properly leveled and the locking nuts are securely tightened up against the base frame of the washer.
- Check and determine all five of the shipping bolts and spacers have been fully removed from the rear panel of the washer.
- Check for proper load size and distribution. If clothes load is too small, add a few towels to balance the clothes load better.
- Check the tightness of the rear pulley bolt. Tighten if necessary.
- Clean floor and bottom side of washer feet.

Rubber Feet Leaving Marks on Floor

- Use a pencil eraser to remove mark.
- Walk washer into location, do not drag.

Additive Cups Full of Water

- Small amount of water in bottom of additive cups is normal.
- Remove and wash Dispenser Tray, removable Cup, and Rinse Cap.
- Level washer.

Buttons do not Respond

- Options cannot be changed while cycle is running. Press **Start/Pause** once to pause cycle while making selections. Press **Start/Pause** again to restart washer.
- Child Lock feature has been selected. To disable feature press and hold **Chime** and **Delay Start** simultaneously until a beep is heard.
- When display shows "**End**", only the **Power Off** button will function. Press **Power Off** and make new cycle selections.

Troubleshooting Procedures

⚠ WARNING

To avoid risk of electrical shock, personal injury or death, disconnect power to unit before servicing, unless testing requires power.

Component Diagnostics

NOTE: For ohm checks unplug harness connector on console and test from wire insertion side of the harness connectors.

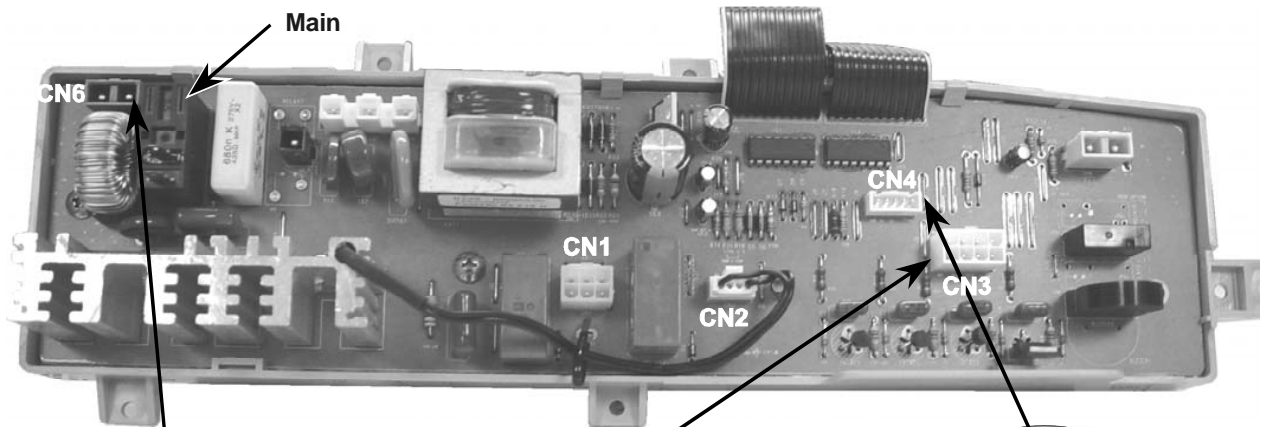

DRAIN PUMP

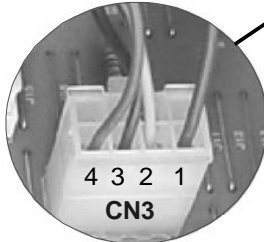
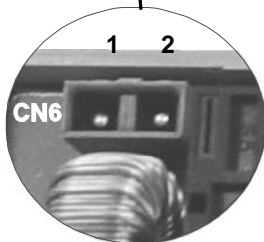

Blue wire Pin 2 on CN6 to Gray wire Pin 1 on CN3 120V or approx 16 ohms

Tub Sump Thermistor/ Pressure SW

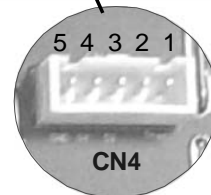

Yellow wire Pin 3 on CN4 to Pink wire Pin 4 (5V+DC or approx 12,000 ohms)

WATER VALVE

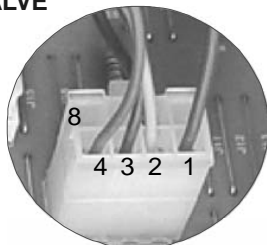

CN3

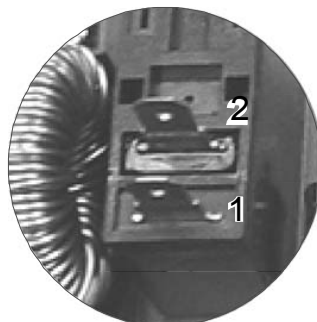

MAIN

(Hot Valve) Red wire Pin 4 on CN3 to White wire Pin 1 on Main. Approx 11,000 ohms or 120 volts.

(Bleach Valve) Orange wire Pin 3 on CN3 to Whitewire Pin 1 on Main. Approx 11,000 or 120 volts.

(Cold Valve) Blue wire Pin 2 on CN3 to White wire Pin 1 on Main. Approx 11,000 ohms or 120 volts.

Troubleshooting Procedures

WARNING

To avoid risk of electrical shock, personal injury or death, disconnect power to unit before servicing, unless testing requires power.

Motor windings

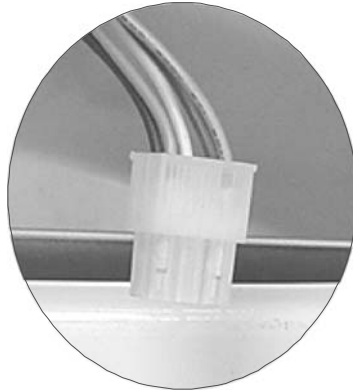
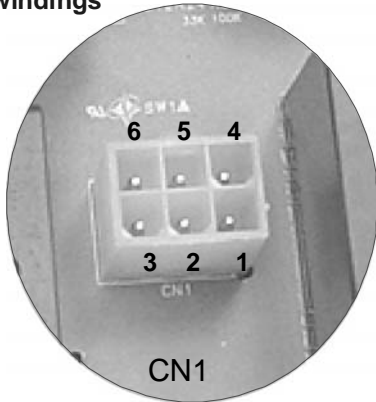

(CN1) Unplug connector and test Resistance at plug.
Rotor Orange Pin 1 to Gray Pin 3 = approx 2.5 ohms);
Stator Yellow Pin 5 to Violet Pin 4 = approx 1 ohms),
Stator Yellow Pin 5 to Blue Pin 6 = approx 1 ohms)

Dispenser Circuit

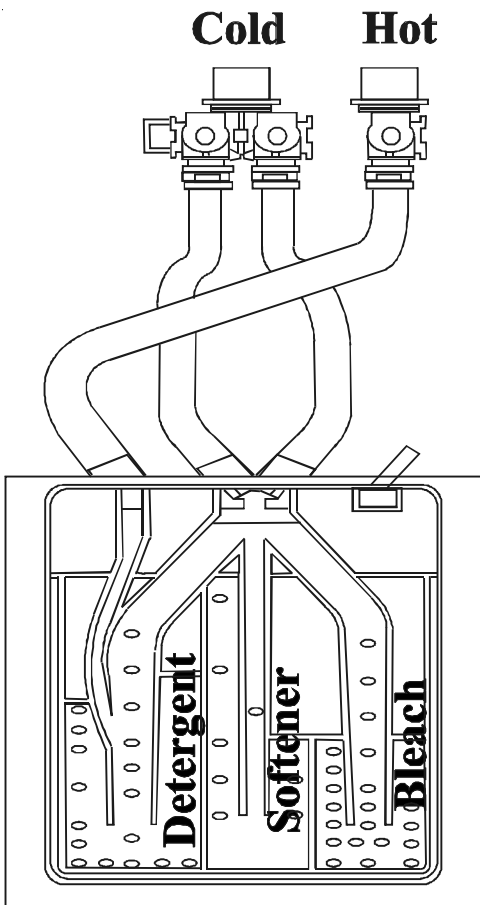

Water temperatures
Non ATC Cold Wash and Rinse = tap temperature
Non ATC Hot Wash = tap temperature
ATC Cold Wash = 65 Degrees +/- 10
ATC Warm Wash = 105 Degrees +/- 10
ATC Warm Rinse = 80 Degrees +/- 10 for final
rinse only, all others are tap cold

Troubleshooting Procedures



WARNING

To avoid risk of electrical shock, personal injury or death, disconnect power to unit before servicing, unless testing requires power.

Fill Circuit

Cold Fill

Cold Hot

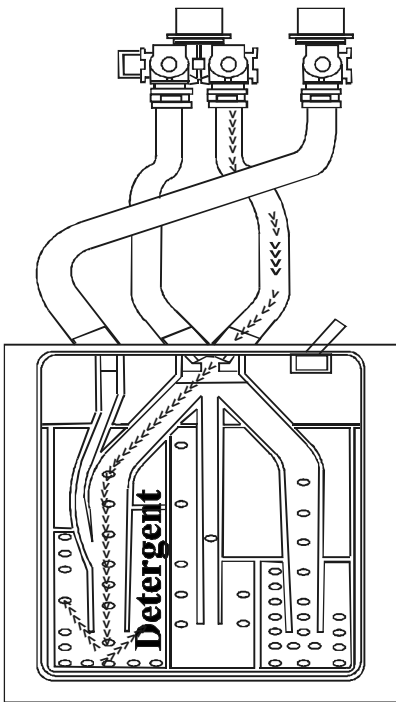

Hot Fill

Cold Hot

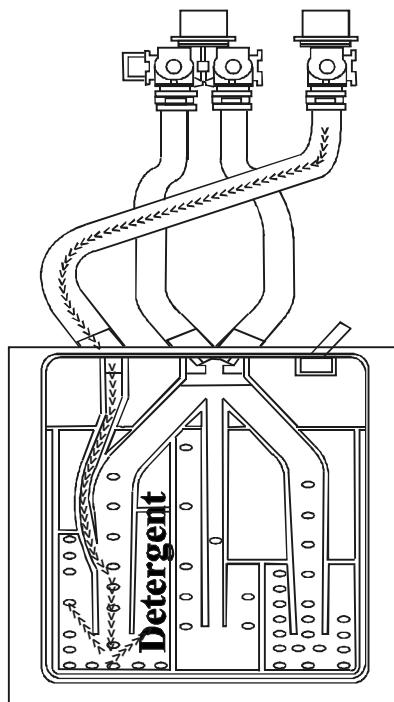

Warm Fill

Cold Hot

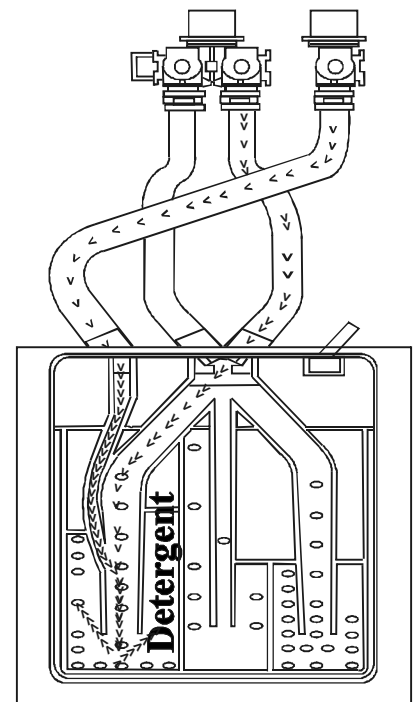

Bleach Fill

Cold Hot

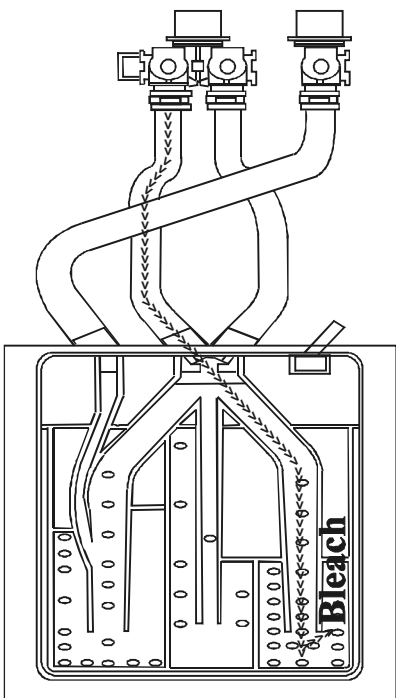

Fabric Softener Fill

Cold Hot

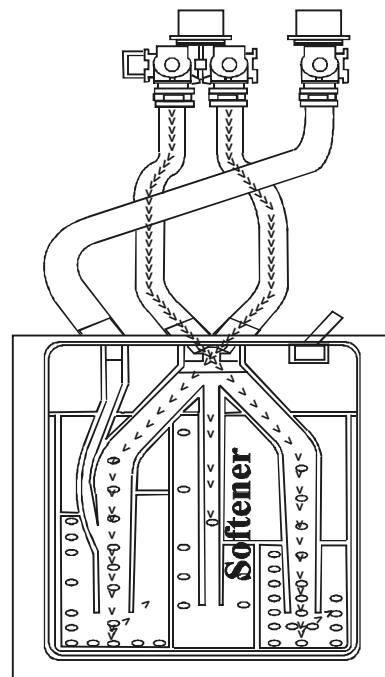

The two streams of cold water are designed to collide redirecting the path of the water to fill the softener reservoir.

Disassembly Procedures



WARNING

To avoid risk of electrical shock, personal injury or death; disconnect power to unit before servicing.

Top Removal

1. Disconnect power supply to unit.
2. Remove 2 screws from washer back.

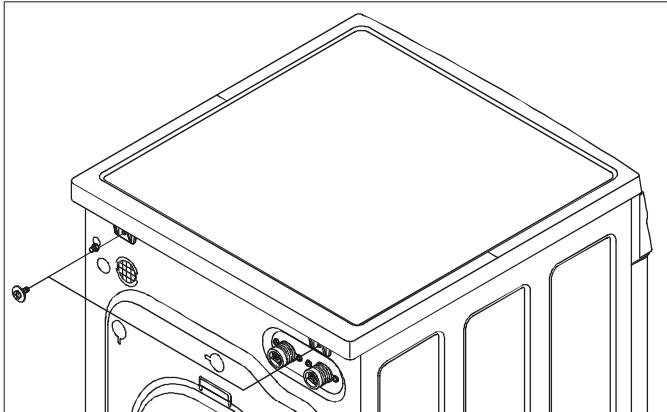

3. Slide Top Cover to the rear of the washer and separate from cabinet.

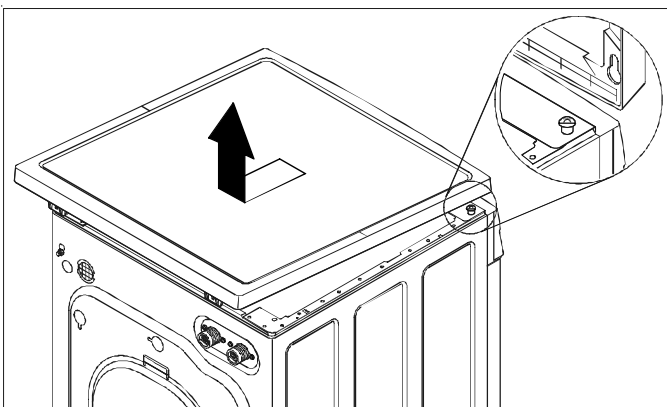

Water Valve Removal

1. Disconnect power supply to unit.
2. Remove Top Cover.
3. Remove hoses.

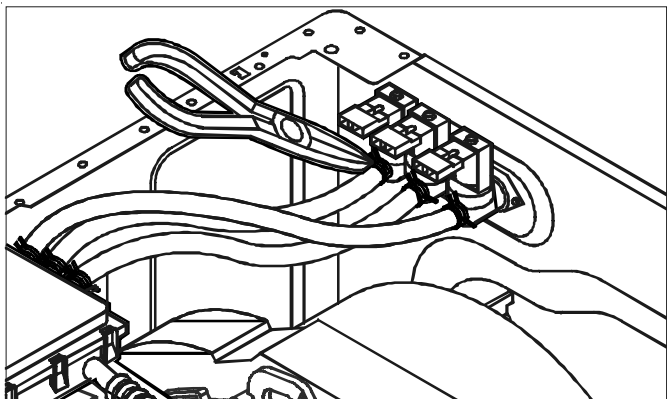

4. Remove connectors.

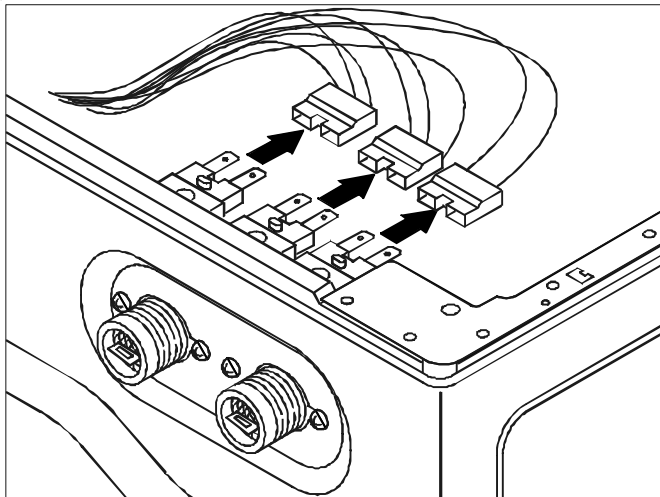

5. Remove screws retaining Water Valves.

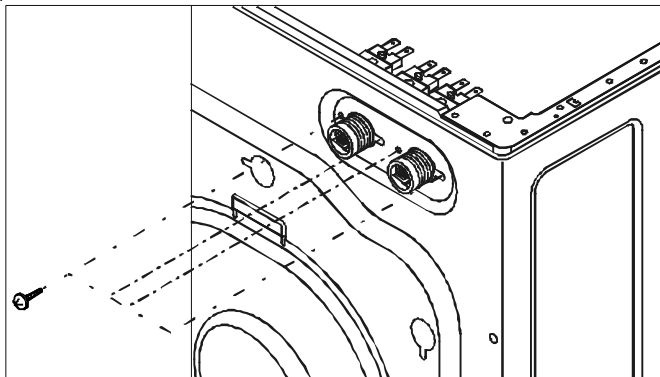

Pressure Valve Removal

1. Disconnect power supply to unit.
2. Remove Top Cover.
3. Remove Wiring connectors.
4. Remove mounting screw.

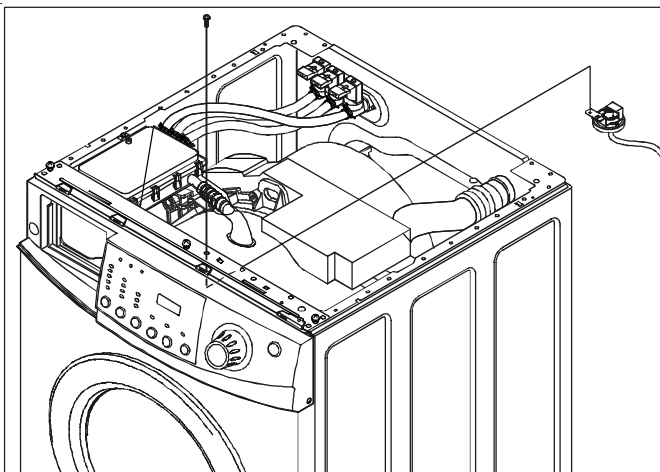

Disassembly Procedures

 **WARNING**

To avoid risk of electrical shock, personal injury or death; disconnect power to unit before servicing.

Drain Pump Removal

1. Disconnect power supply to unit.
2. Gain access to bottom of unit.
3. Remove 4 screws securing panel to the bottom of the cabinet.



4. Remove drain hose and tub hose from pump.

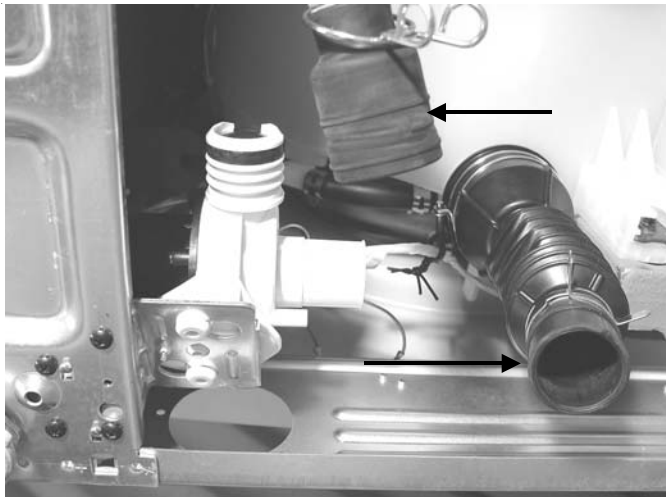

5. Disconnect electrical connector .



6. Remove 4 screws and slide pump mounting bracket to free tabs and remove motor.

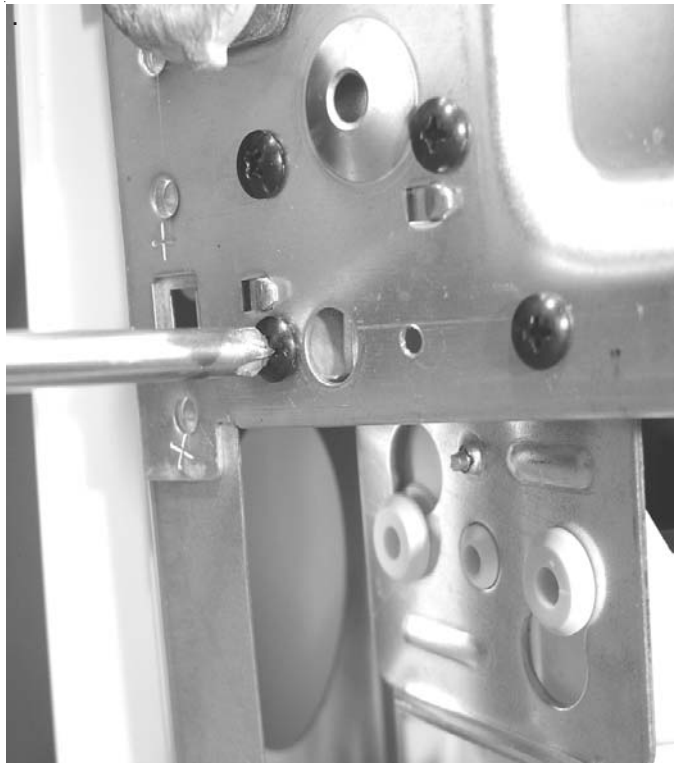

Disassembly Procedures



WARNING

To avoid risk of electrical shock, personal injury or death; disconnect power to unit before servicing.

EMI Filter Removal

1. Disconnect power supply to unit.
2. Remove Top Cover.
3. Remove wiring connectors and ground wires.

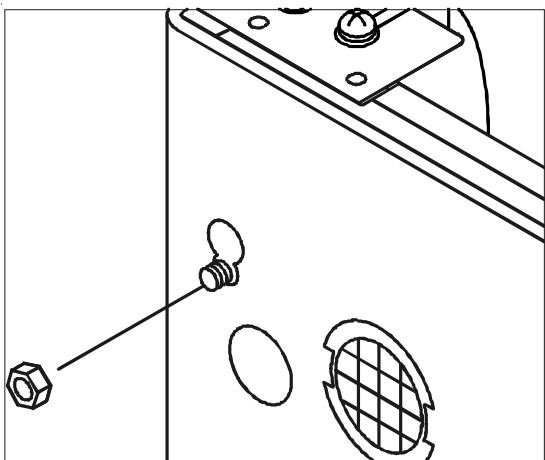
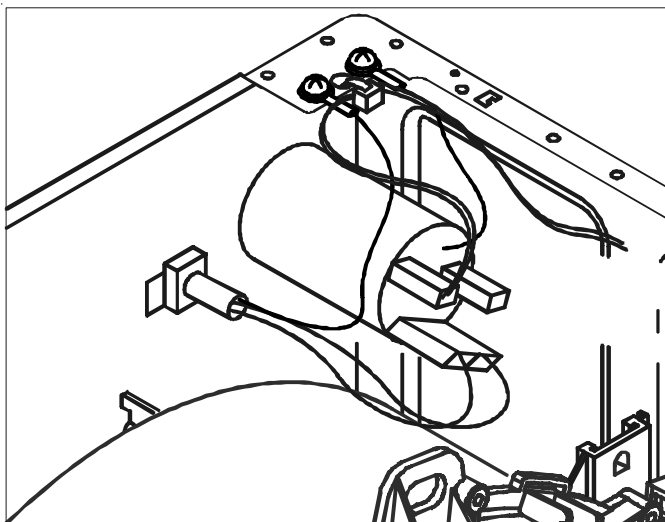

Console/Machine Control Board Removal

1. Disconnect power supply to unit.
2. Remove Dispenser drawer.
3. Remove 2 screws located behind dispenser. Remove 1 screw on console right side.

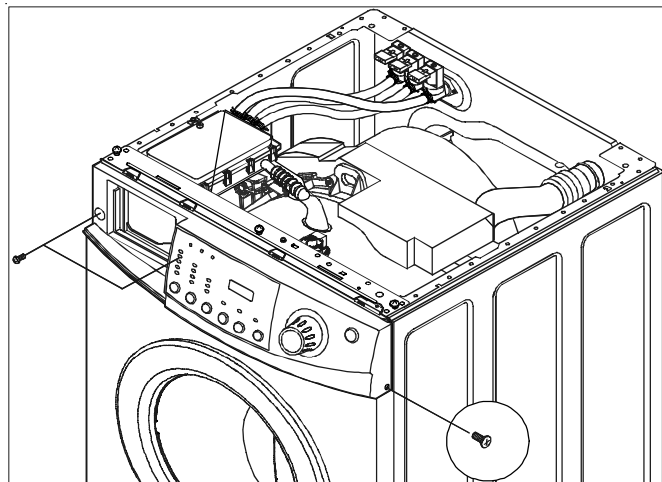

4. Tip Console to access connectors.



NOTE: Clip wire ties if necessary to gain access to Control Board.

CAUTION: Do not reassemble washer without replacing clipped wire ties. Do not remove wire ties if replacement are not available.

5. Remove connectors from Control Board back.

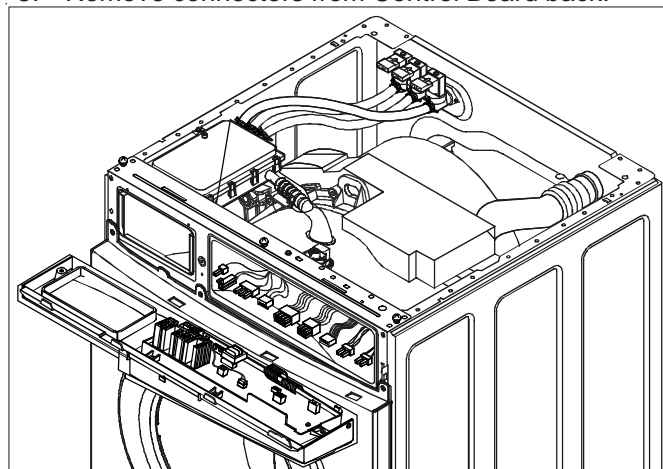

Disassembly Procedures



WARNING

To avoid risk of electrical shock, personal injury or death; disconnect power to unit before servicing.

6. Remove 5 screws retaining Control Board to Console.



8. Separate the Control Board from the Console.

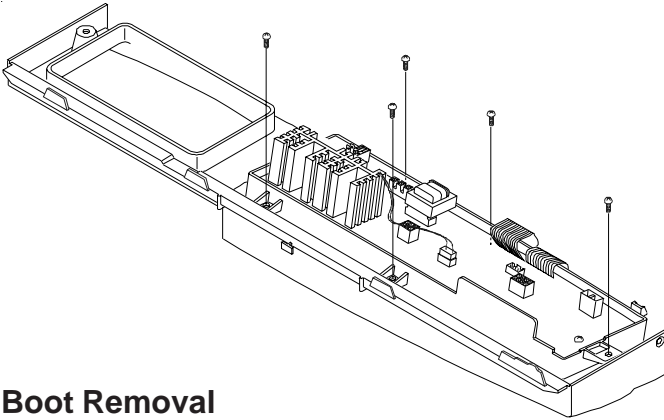

Boot Removal

1. Disconnect power supply to unit.
2. Remove Boot retainer spring.

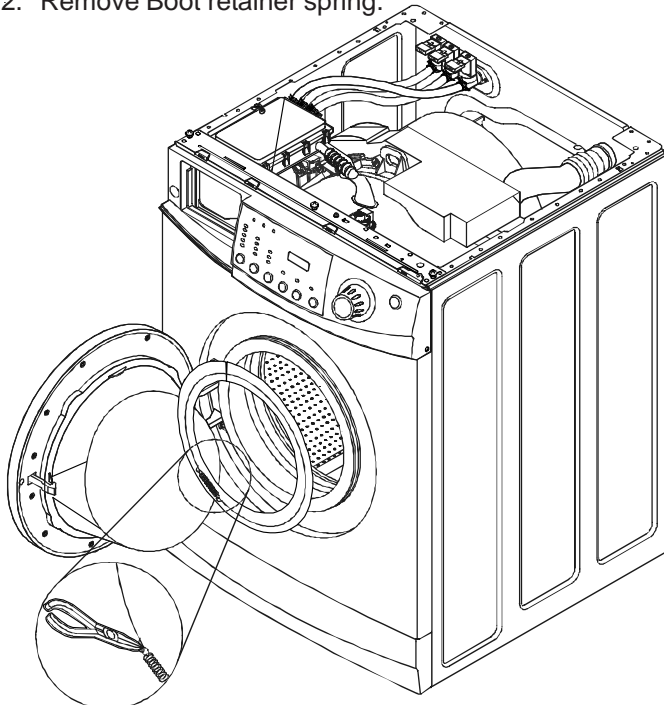

3. Remove boot retainer wire from groove.



4. Pull boot over lip on Front Panel.



Door Assembly Removal

1. Remove Door Hinge with screwdriver and 5/16" wrench.

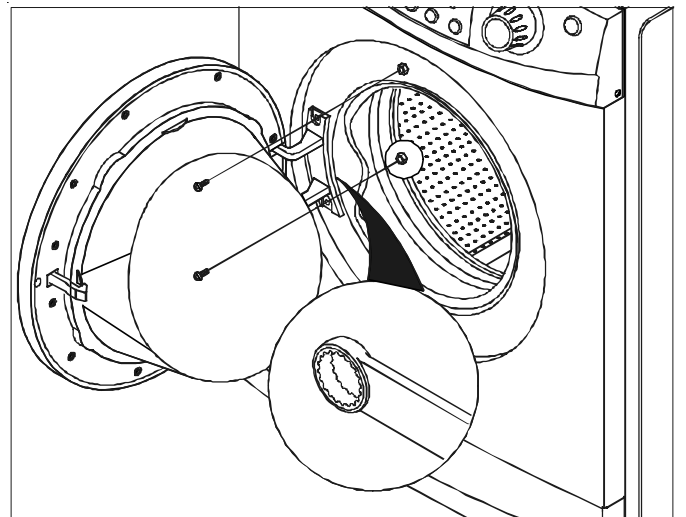

Disassembly Procedures



WARNING

To avoid risk of electrical shock, personal injury or death; disconnect power to unit before servicing.

Disassemble Door Assembly

1. Disconnect power supply to unit.
2. Remove Door Assembly
3. Remove screws on door inner panel.

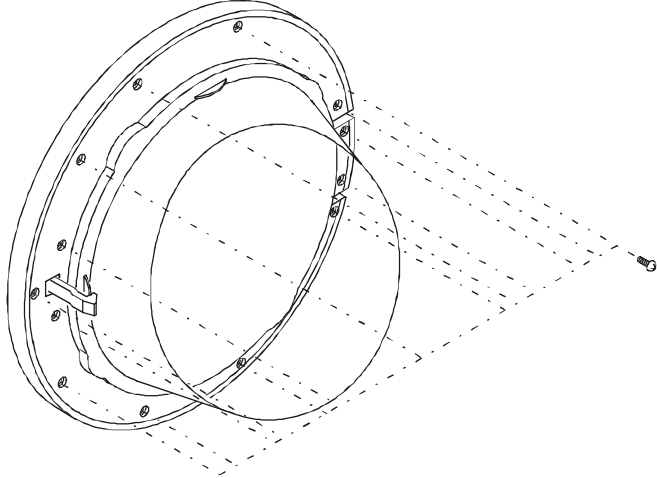

4. Remove pin through door strike.

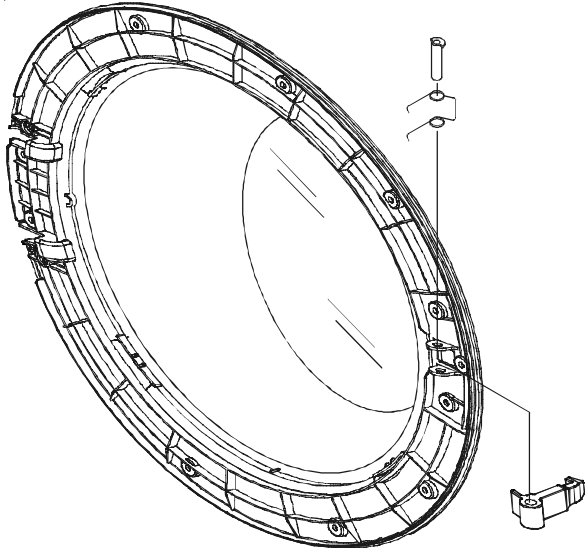

5. Unsnap handle from retainer.

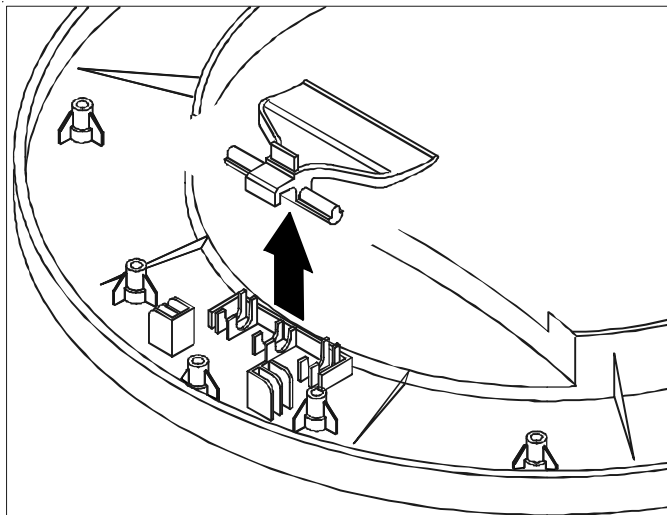

6. Remove glass sight window from frame.

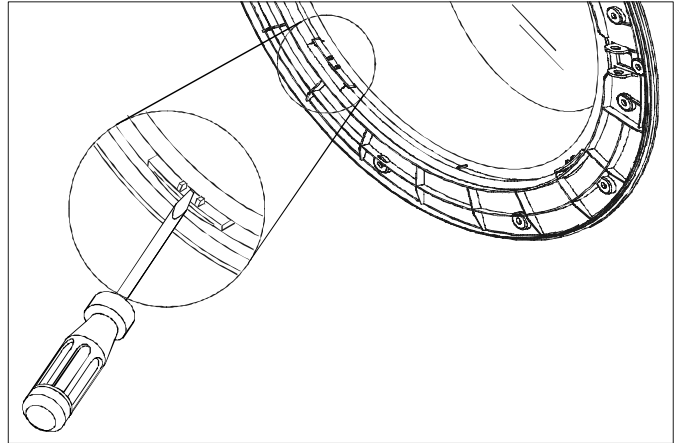

NOTE: Align indent in glass with drain hole in frame during reassembly.

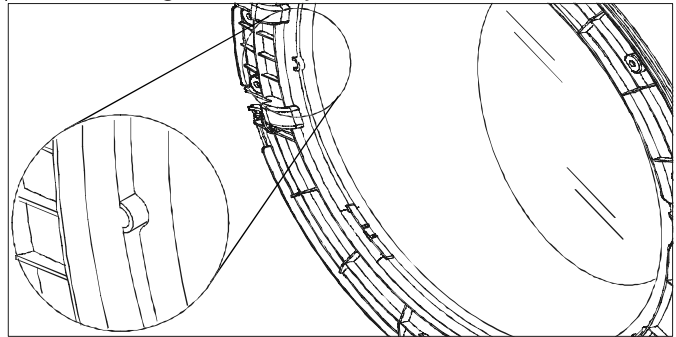

Front Panel/ Door Latch Removal

1. Disconnect power supply to unit.
2. Remove Console.
3. Remove Toe Panel.

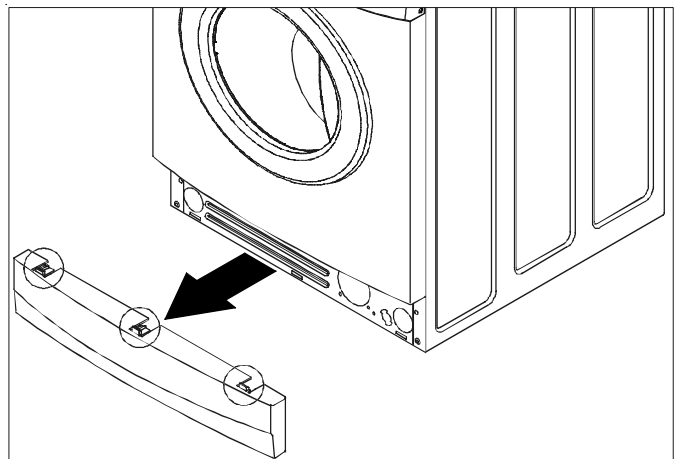

4. Remove 3 screws on Front Panel bottom.



Disassembly Procedures

WARNING

To avoid risk of electrical shock, personal injury or death; disconnect power to unit before servicing.

5. Remove 6 screws on Front Panel top and bottom.

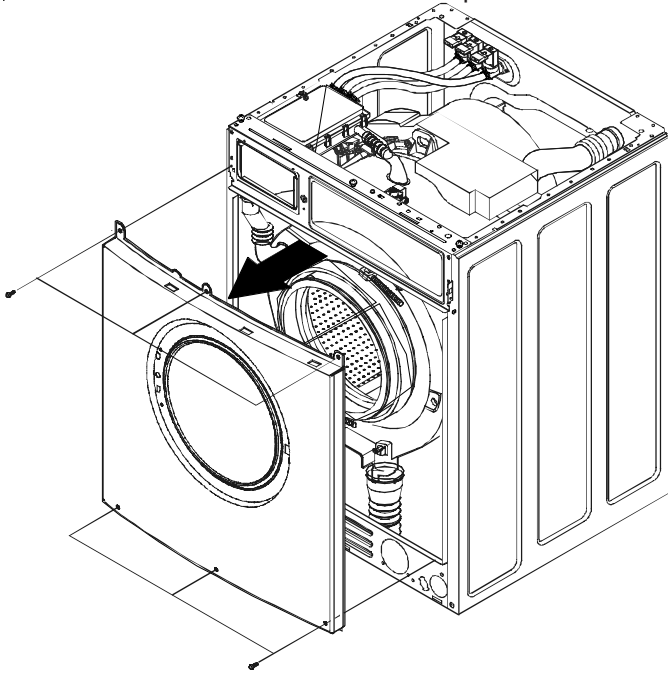

8. Remove 2 screws retaining Door Latch to Front Panel.

Motor and Belt Removal

1. Disconnect power supply to unit.
2. Remove 3 screws retaining Back Cover.

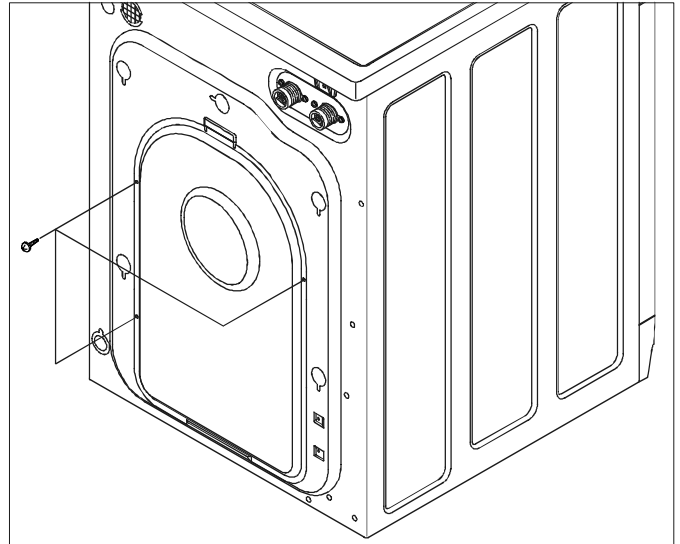

6. Lift front Panel from hanger hooks.

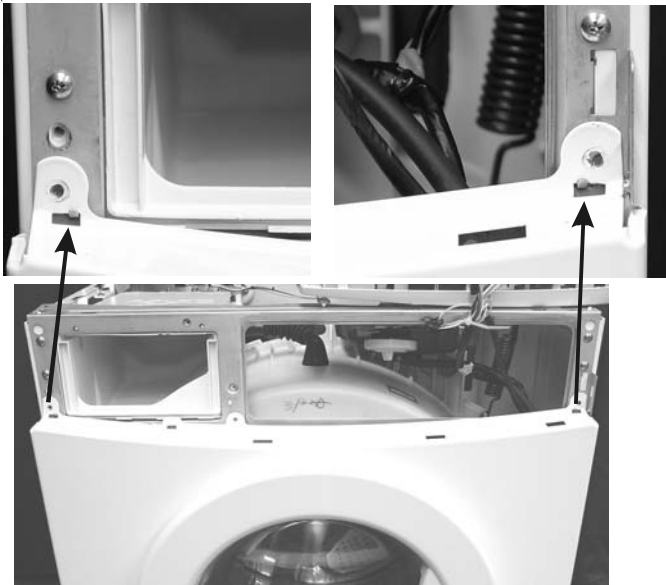

3. Remove belt by pulling belt while rotating pulley causing belt to derail from motor.

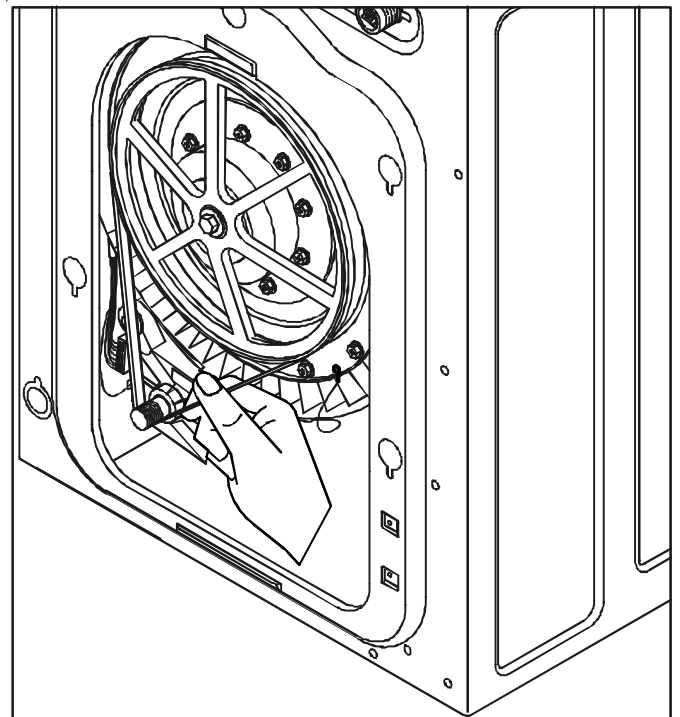

7. Disconnect Door Latch wire connector.



4. Remove Motor wiring connector and ground wires.

Disassembly Procedures

WARNING

To avoid risk of electrical shock, personal injury or death; disconnect power to unit before servicing.

5. Remove Motor wiring connector and ground wires.

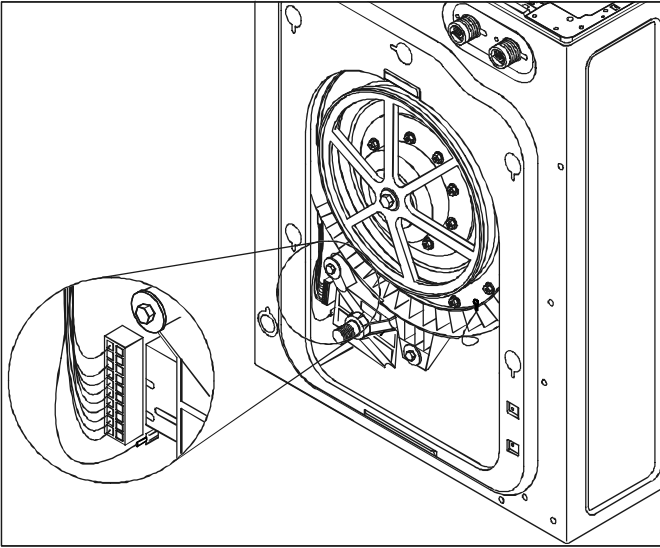

4. Insert a 3/8" drive extension into hole in bearing cover to lock pulley from rotating.



6. Remove 2 1/2" Motor mounting bolts. Bolt torque is 10.8-18.1 ft. lbs.

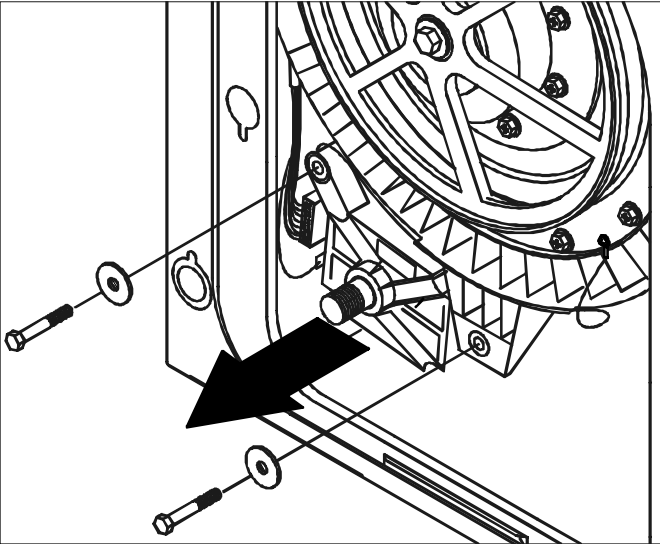

5. Loosen bolt retaining pulley. Bolt torque is 21.7-28.9 ft. lbs.



7. Swing Motor down and to the left to remove.



Tub Removal

1. Disconnect power supply to unit.
2. Remove Top Cover.
3. Remove Back Cover.
4. Disconnect and remove Drive Motor and belt.
5. Disconnect Drain Pump hose and wiring.
6. Remove Front Panel.
7. Remove wire harness and hose from Pressure Switch. Remove the Pressure Hose from tub bottom.
8. Remove Console mounting bracket.

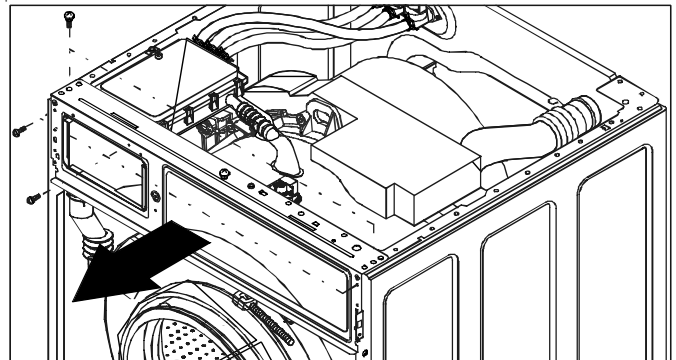

Tub Pulley Removal

1. Disconnect power supply to unit.
2. Remove Back Cover.
3. Remove Belt.

Disassembly Procedures

WARNING

To avoid risk of electrical shock, personal injury or death; disconnect power to unit before servicing.

9. Remove Fill Hose and Dispenser Hose from Tub.

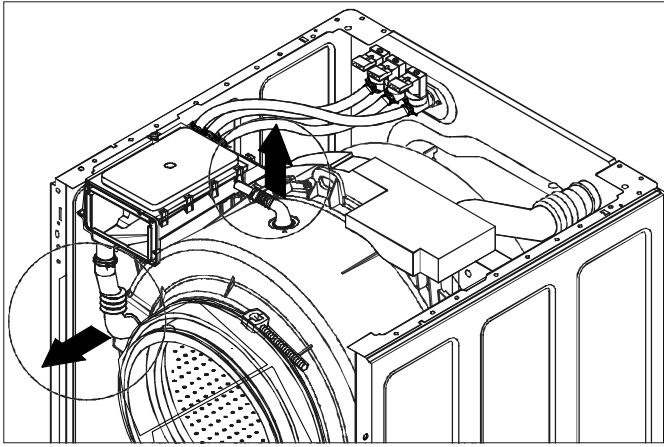

10. Remove Dispenser Feeder Hoses.

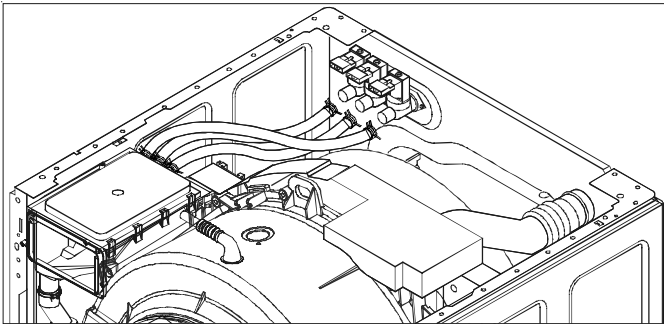

11. Remove screw retaining Dispenser.

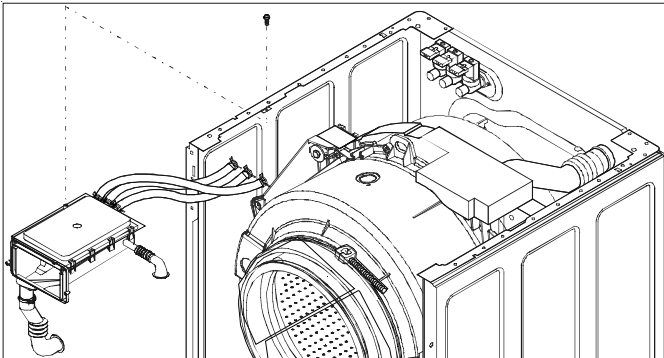

12. Remove Dispenser from washer.

13. Remove 1/2" bolts retaining upper counter weight.
Bolt torque is 10.8 to 18.1 ft. lbs.

14. Remove Upper Counter Weight.

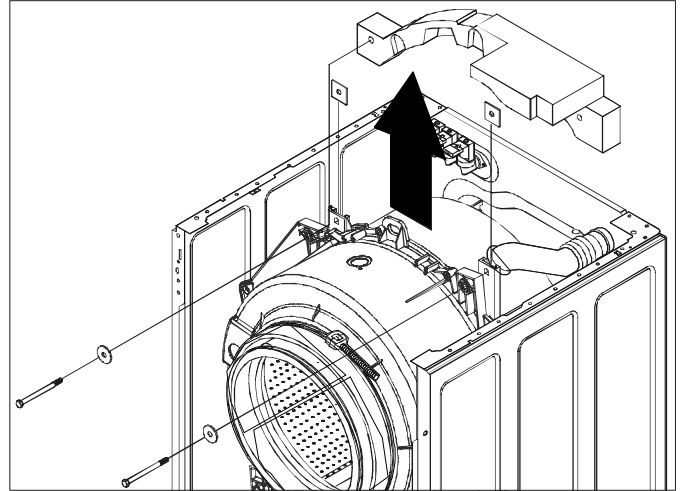

15. Disconnect Sump Thermistor wire harness.



16. Remove 3 1/2" bolts retaining Lower Counter Weight.
Bolt torque is 10.8 to 18.1 ft. lbs.

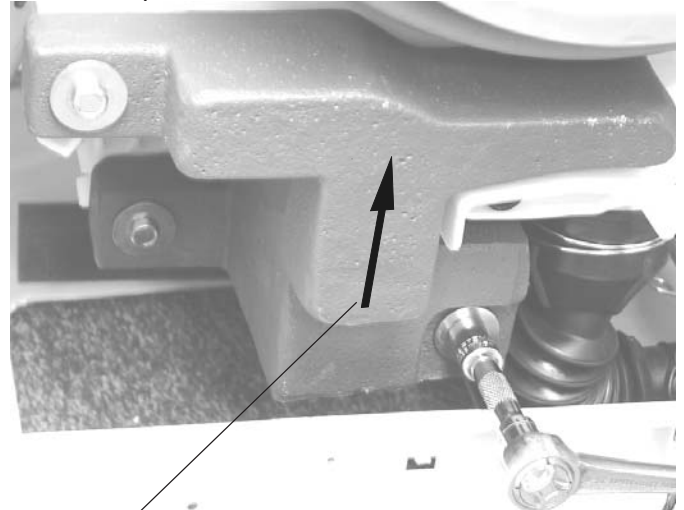

NOTE: Mark the counter weight front surface for ease of reassembly.

Disassembly Procedures

! WARNING

To avoid risk of electrical shock, personal injury or death; disconnect power to unit before servicing.

17. Remove Lower Counter Weight.



18. Remove remaining wire harnesses and hose from tub.

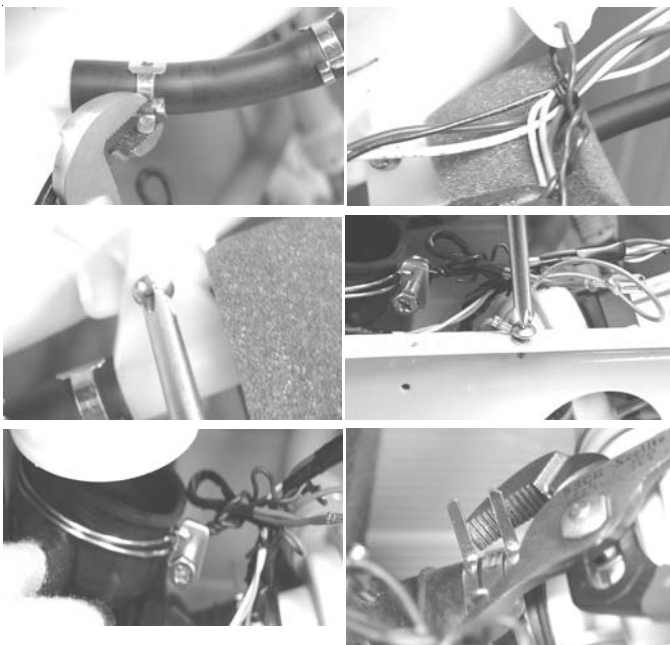

19. Remove 2 1/2" bolts retaining the Struts. All Strut bolts are torqued to 18.1-25.3 ft. lbs.

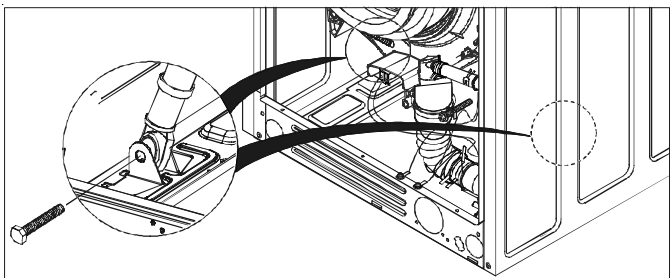

20. Move Struts to center of washer.

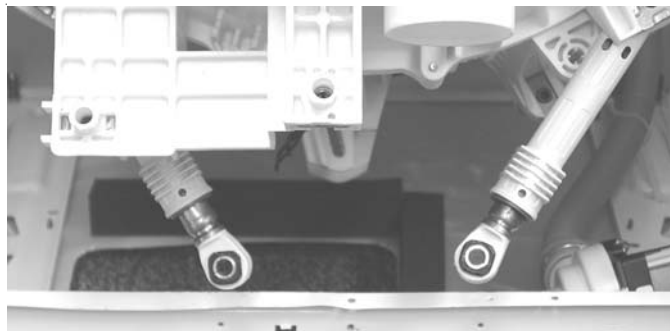

21. Mark location and position of Suspension Springs.

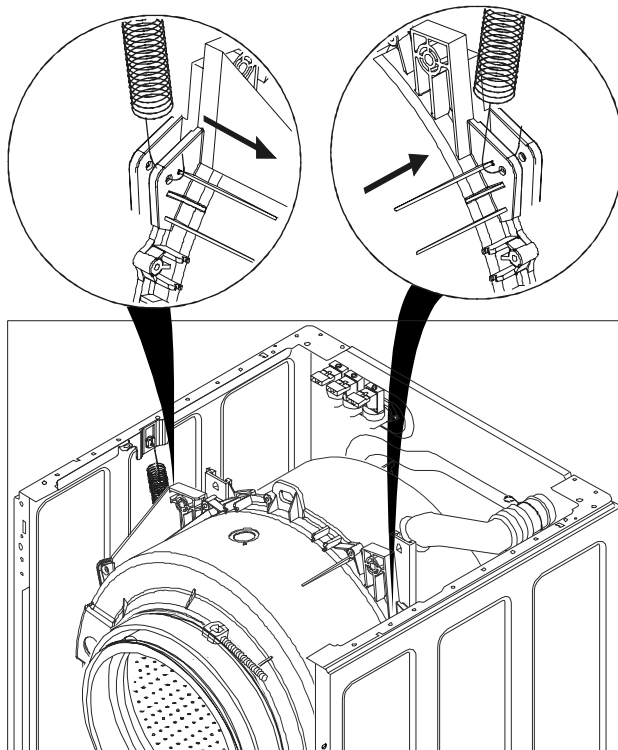

22. Reinstall Upper Counter Weight bolts to tub without weight in place. Use these as handles when lifting tub.



Disassembly Procedures

 **WARNING**

To avoid risk of electrical shock, personal injury or death; disconnect power to unit before servicing.

23. Use weight bolts to lift tub and unhook Suspension Springs.



24. Grasp the front and rear of the tub and remove from cabinet.

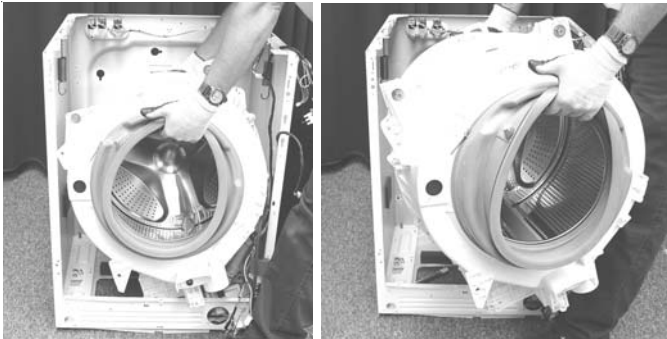

25. Loosen screw and remove boot from tub lip.

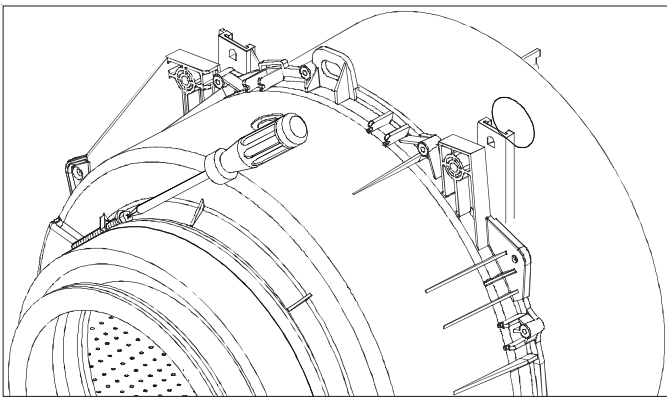

26. Remove rear Spinner Pulley.

NOTE: After Spinner Pulley bolt is removed Spinner can fall from tub. Block Spinner to prevent Spinner from falling free.

27. Remove bolts around perimeter and separate the tub halves.

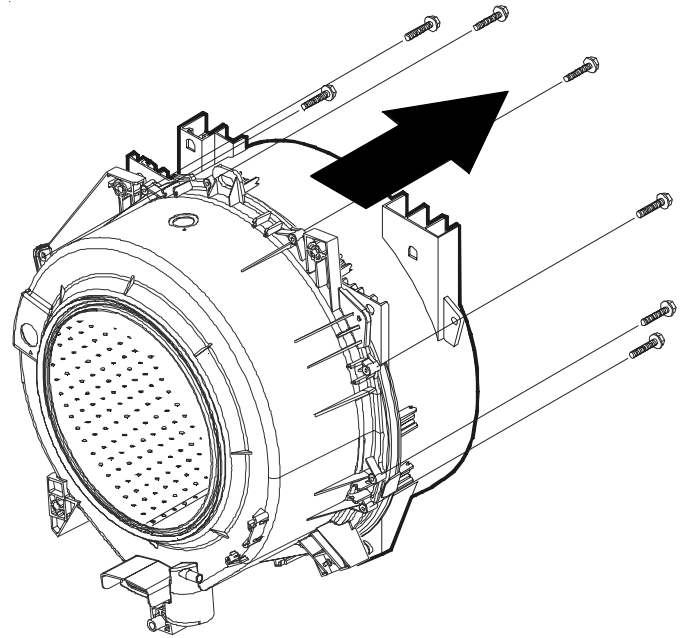

NOTE: During reassembly snug bolts in a cross pattern before tightening to prevent tub warp.

28. Remove Spinner.

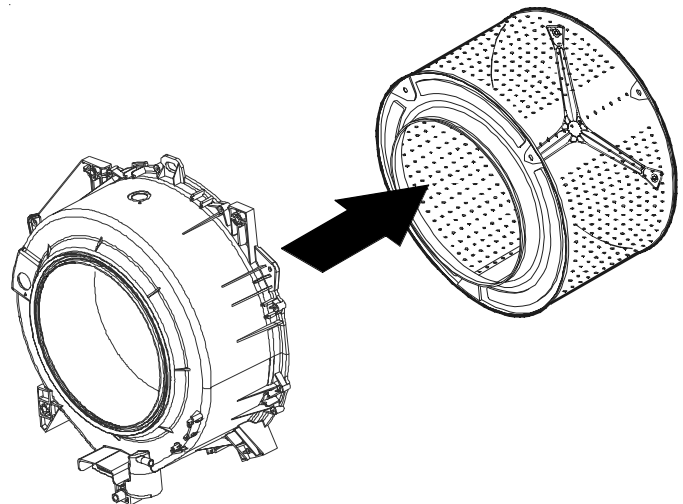

Disassembly Procedures



WARNING

To avoid risk of electrical shock, personal injury or death; disconnect power to unit before servicing.

29. Install new Gasket between front and rear tub halves.



30. Install new Spinner and reassemble washer by reversing the preceding steps.

Appendix A



HIGH-EFFICIENCY WASHER INSTALLATION INSTRUCTIONS

**MACHINE À LAVER HAUTE EFFICACITÉ
GUIDE DE MISE EN SERVICE**

**INSTRUCCIONES PARA LA INSTALACIÓN
DE LA LAVADORA DE ALTA EFICIENCIA**

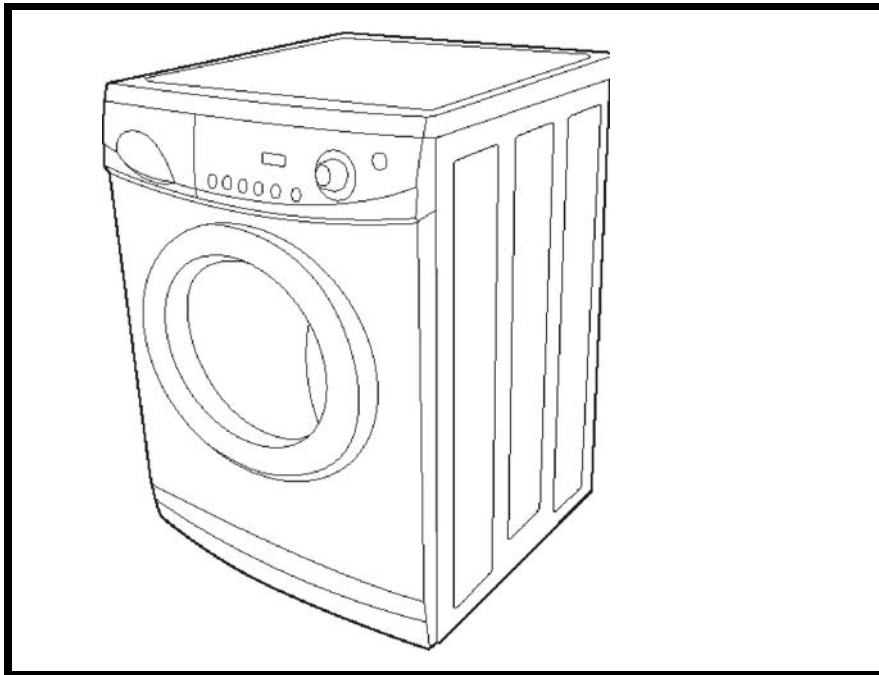

LEAVE THESE INSTRUCTIONS WITH THE OWNER

LAISSER CE GUIDE DE MISE EN SERVICE AU PROPRIÉTAIRE

DEJAR ESTAS INSTRUCCIONES CON EL PROPIETARIO

(7/28/04 Revision)

2201459

READ THIS BEFORE YOU START...

Tools needed for installation:

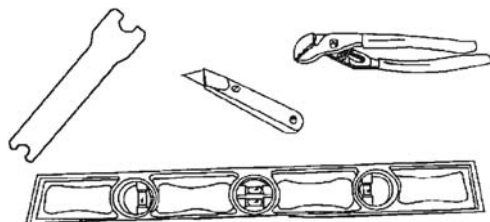

- Multi wrench
- Utility knife
- Channel lock
- Level

PARTS supplied for installation:

Cable tie to secure drain hose to standpipe, inlet hose or laundry tub

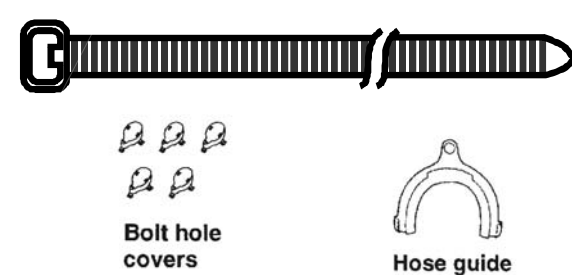

Bolt hole covers
Hose guide

ELECTRICAL

Refer to serial plate for specific electrical requirements. For more detailed information refer to section on **Electrical Requirements**.

WATER

Washer needs two standard 3/4 inch water supply faucets with a pressure between 20–120 pounds per square inch. For more detailed information refer to section on **Water Requirements**.

CABINET DIMENSIONS

WASHER DIMENSIONS	INCH (CM)
A. Height – Overall*	33.25" (84.5)
B. Depth to Front of Control Dial	26" (66.1)
C. Width	23.5" (59.7)
D. Depth – With Washer Door Open 90°	41.25" (104.3)
E. Depth	24" (60.9)

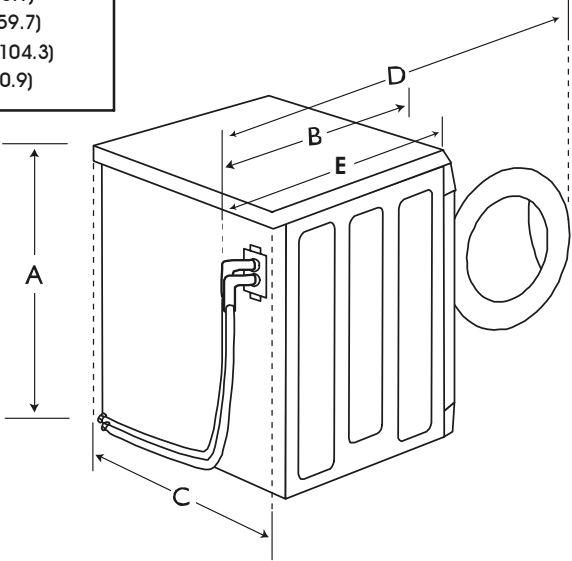

Note:
The height of the washer from top to floor is 33 1/4" this includes the leveling leg screwed all the way in. The customer can unscrew the leg out an additional 7/8" for a total overall height of 34 1/8".

BASIC LOCATION REQUIREMENTS:

ELECTRICAL

- 120 Volt 60 Hz 15 AMP Fuse or Circuit Breaker
- Individual branch circuit serving only the washer is recommended.
- The washer is equipped with a power cord.
NEVER USE AN EXTENSION CORD.

GROUNDING

ELECTRICAL GROUND IS REQUIRED ON THIS APPLIANCE.

Appliance is equipped with a power cord having a 3-prong grounding plug for use in a properly installed and grounded outlet.



- Improper connection of the equipment-grounding conductor can result in a risk of electrical shock. Check with a qualified electrician or serviceman if you are in doubt as to whether the appliance is properly grounded. Do not modify the plug provided with the appliance – if it will not fit the outlet, have a proper outlet installed by a qualified electrician.

IMPORTANT SAFETY PRECAUTIONS

- To prevent unnecessary risk of fire, electrical shock or personal injury, all wiring and grounding must be done in accordance with the National Electrical Code ANSI/FNPA, No. 70-Latest Revision and local codes and ordinances. It is the personal responsibility and obligation of the appliance owner to provide adequate electrical service for this appliance.

ADDITIONAL GROUNDING CONNECTIONS

A grounding kit (Part No. 12001875) is available. It contains the ground wire, clamp, ground screw and washer. Connect the ground wire to back of unit with the cabinet ground screw and washer. Secure the other end of ground wire to a grounded **COLD** metal water pipe.

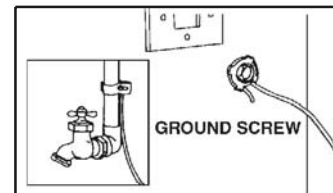

NEVER CONNECT GROUND WIRE TO PLASTIC PLUMBING LINES, GAS LINES OR HOT WATER PIPES.

WATER

To correctly fill the washer in the proper amount of time, Water pressure of 20 to 120 p.s.i. is required. Water pressure less than 20 psi may cause a failure in the water valve and may not allow the water valve to shut off completely. Or may extend the fill time beyond what the washer controls will normally allow and result in the washer turning off. A time limit is built into the controls in the event of an internal hose becoming loose and avoids a flooded home.

The water valve Hot and Cold water faucets must be within 4 feet of the back of the washer for inlet hoses provided with the washer. NOTE: Accessory inlet hoses are available in various lengths up to 10 feet for faucets more than 4 feet from the back of the washer.

To Avoid The Possibility Of Water Damage:

- Have Water Faucets Easily Accessible
- Turn Off Faucets When Washer Is Not In Use.

DRAIN FACILITY

Recommended height of the standpipe is 18". The drain hose must be routed through the drain hose clip to the standpipe. Standpipe must be large enough to accept the outside diameter of the drain hose. The drain hose is attached at the factory.

FLOORING

For best performance the washer must be installed on a solidly constructed floor. Wood floors may need to be reinforced to minimize vibration and/or unbalanced load situations. Carpeting and soft tile surfaces are contributing factors in vibration and/or tendency for a washer to move slightly during the spin cycle. Never install the washer on a platform or weakly supported structure.

LOCATION CONSIDERATIONS

It is recommended the washer never be installed in areas where water may freeze since the washer will always maintain some water in the water valve, pump and hose areas. This can cause damage to belts, pump, hoses and other components. Operating temperature should be above 60 °F.

ALCOVE OR CLOSET INSTALLATION

MINIMUM CLEARANCES FOR CLOSET AND ALCOVE INSTALLATIONS:

Sides – 0 in / 0 mm Rear – 0 in / 0 mm
Top – 0 in / 0 mm Closet Front – 0 in / 0 mm

The closet front must have a total unobstructed air opening of 72 in². / 465 cm² minimum, if both washer and dryer are installed together. A louvered door with equivalent air opening is acceptable. Washer alone does not require specific air opening.

UNDERCOUNTER INSTALLATION

MINIMUM CLEARANCES FOR UNDERCOUNTER INSTALLATIONS:

Sides – 0 in / 0 mm Rear – 0 in / 0 mm
Top – 0 in / 0 mm Front – 0 in / 0 mm

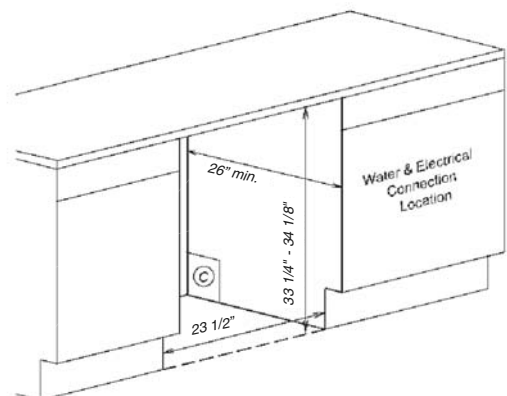

STACKING KIT INSTALLATION



A special stacking kit is available to allow stacking of the dryer on top of the washer. This is available as an accessory item and is available through your selling dealer. The model number for the accessory kit is MAL2424AXX

ADDITIONAL INFORMATION

50-HERTZ OPERATION

This Maytag appliance is manufactured for operation on 60 Hz AC approved electrical service. This model is not designed for use on 50 Hz AC electrical services and conversion of the product from 60 to 50 Hz operations is not recommended. For additional information on 50 Hz products, write:

MAYTAG INTERNATIONAL, INC.
1475 East Woodfield Road
Schaumburg, Illinois 60173
Phone: 847-273-3100

FOR TECHNICAL ASSISTANCE, REPLACEMENT PARTS AND ACCESSORIES

For technical assistance or if your washer requires replacement parts or accessories, contact **Maytag Customer Service, toll-free 1-888-4-Maytag** for information on the nearest authorized Maytag Parts Distributor.

Proper installation is the responsibility of the owner; **Service Calls Performed As A Result Of Improper Set-up, Adjustment And/Or Connection Are The Responsibility Of The Installer.**

UNPACKING THE WASHING MACHINE

Unpack your washing machine and inspect it for shipping damage and have you have received all of the items shown on page 2. If the washing machine was damaged during shipping or you do not have all of the items, contact your Maytag dealer immediately.

IMPORTANT TO INSTALLER

Please Read The Following Instructions Carefully Before Installing The Washing Machine.

These Instructions Should Be Retained For Future Reference.

Remove The Door From All Discarded Appliances To Avoid The Danger Of A Child Suffocating.

STEP 1

PREPARE WASHER

Removing The Shipping Bolts

Before using the washing machine, you must remove the five shipping bolts from the back of the unit.

1. Loosen all bolts with the supplied wrench before removing them.
2. Slide the bolt and spacer up and remove the bolt with spacer through the hole in the rear wall of the washer. Repeat for each bolt.
3. Fill the holes with the supplied plastic covers.
4. Keep the shipping bolts and spacers for future use.

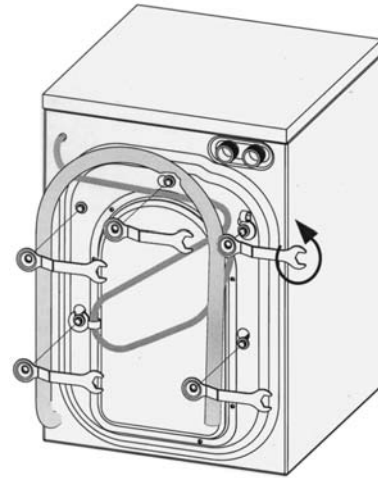

STEP 2

INSTALLING THE WASHING MACHINE

Selecting a location

Before you install the washing machine, select a location with the following characteristics:

- A hard, level surface (if the surface is uneven, see “Adjusting the leveling feet,” below)
- Locate away from direct sunlight.
- Adequate ventilation
- Room temperature that will not fall below 32°F or 0°C.
- Away from sources of heat such as coal or gas
- Make sure that the washing machine does not stand on its power cord.
- Carpeting must not obstruct ventilation openings when the washing machine is installed on a carpeted floor.

STEP 3

INSTALL THE WASHER

(NOTE: Under the counter installation do not require removal of the work top. Proceed with the following instructions.)

1. Place the drain hose in the drain facility. Be sure an airtight connection is **NOT** made between the drain hose and the standpipe. Standpipe must be at least 18" high.

NOTE: If drain standpipe is in excess of 5 feet above floor level, a drain hose extension kit (Part #12002482) will need to be installed. If drain standpipe is in excess of 10 feet above floor level, a pump accessory kit (Part #12001674) may need to be installed.

NOTE: Caution must always be exercised to avoid collapsing or damaging the drain hose. For best performance the drain hose should not be restricted in any way, through elbows, couplings or excessive lengths.

For installations where the drain hose cannot be conveniently elevated to at least 18", the drain hose must be supported.

2. Check the inlet hose to ensure a washer is inside of each fill hose. Thread the inlet hoses to the HOT and COLD faucet connections. On the other end of the hose, check for one rubber washer per hose and install each fill hose to the water valve. Make sure the hose marked "HOT" is attached to the HOT faucet. Tighten by hand until snug and then 2/3 of a turn with pliers. **DO NOT OVERTIGHTEN.**
3. Turn on "HOT" and "COLD" water supply and check all connections at the water valve and the faucet for leaks. **NOTE:** Accessory inlet hoses are available in various lengths up to 10 feet.
4. Plug power cord into a grounded 120 volt 60 Hz approved electrical service protected by a 15-amp fuse or comparable circuit breaker. This washer is grounded through the third prong of the power cord when plugged into a three prong grounded receptacle.
5. Slide washer into position.
6. Level washer by turning the leveling legs in or out as necessary by hand. When the washer is level, tighten the leveling leg lock nuts up against the base of the washer using the wrench supplied with the washer. **NOTE:** The washer must be leveled on all 4 sides. A carpenter's level should be used on all 4 corners of the washer. ***It's a good idea after the first dozen washes to recheck the levelness of the washer.***

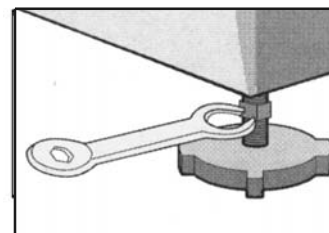
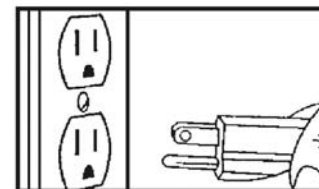
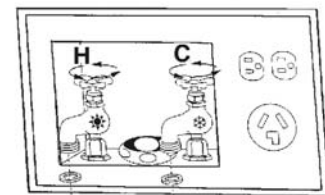
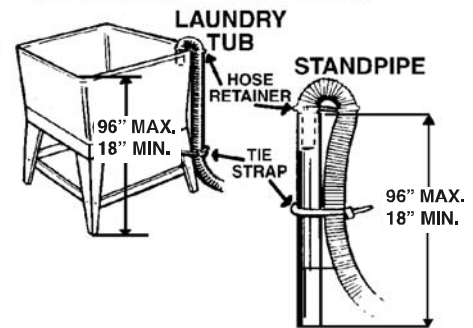
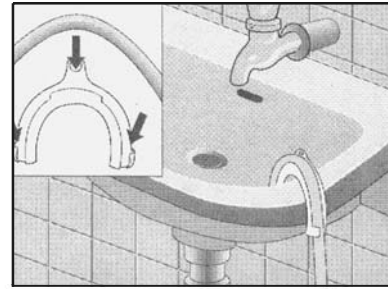

If installing under a counter:

Carefully move the washer in front of its final location. Adjust the rear leveling legs to the required height and level the washer across the back of the washer. Tighten the leveling locking nuts up against the bottom of the washer base with the wrench. Adjust the front leveling legs to level the washer in respect to the rear leveling legs. Gently lift up on the front of the washer and slide back into the recess.

With the washer in its final position, place a level along the top edge of the washer. (no rocking of the washer should exist). Adjust the front leveling legs up or down to ensure the washer is resting solid. Turn the lock nuts on each leg up towards the base of the washer and snug with a wrench.

NOTE: Keep the leg extension at a minimum to prevent excessive vibration. The farther out the legs are extended the more the washer will vibrate and possibly walk.

FINAL INSTALLATION CHECKLIST

- o Instruction and Installation Kit have been removed from tub.
- o Shipping bolts and spacers have been removed.
- o Washer is plugged into electrical outlet and is properly grounded.
- o Water hoses are connected to the faucets with inlet screens and washers.
- o Water is turned on and checked for leaks at faucet and water valve connections on back of washer.
- o Drain hose is properly located into drain facility and is not collapsed or damaged.
- o Washer has been properly leveled. All legs should be firmly on the floor and leveling leg lock nuts tightened up against the bottom of the washer base frame.
- o Washer fills properly on all temperature selections.
- o Test for proper operation by running the washer through a complete cycle.

COLD WEATHER STORAGE

The following precautions should be taken if a washer is to be stored, after use, where it would be subject to freezing conditions.

1. Turn off the water supply, then remove the inlet hoses from the faucets.
2. Place the end of the inlet hoses into a bucket or container. Select a fill cycle and energize the water valve by selecting a warm water setting. A few seconds of fill is sufficient to empty the inlet hoses.
3. Disconnect from electrical supply.
4. Lower the drain hose to floor level and tilt washer backwards to remove water from the drain hose and pump.

Appendix B

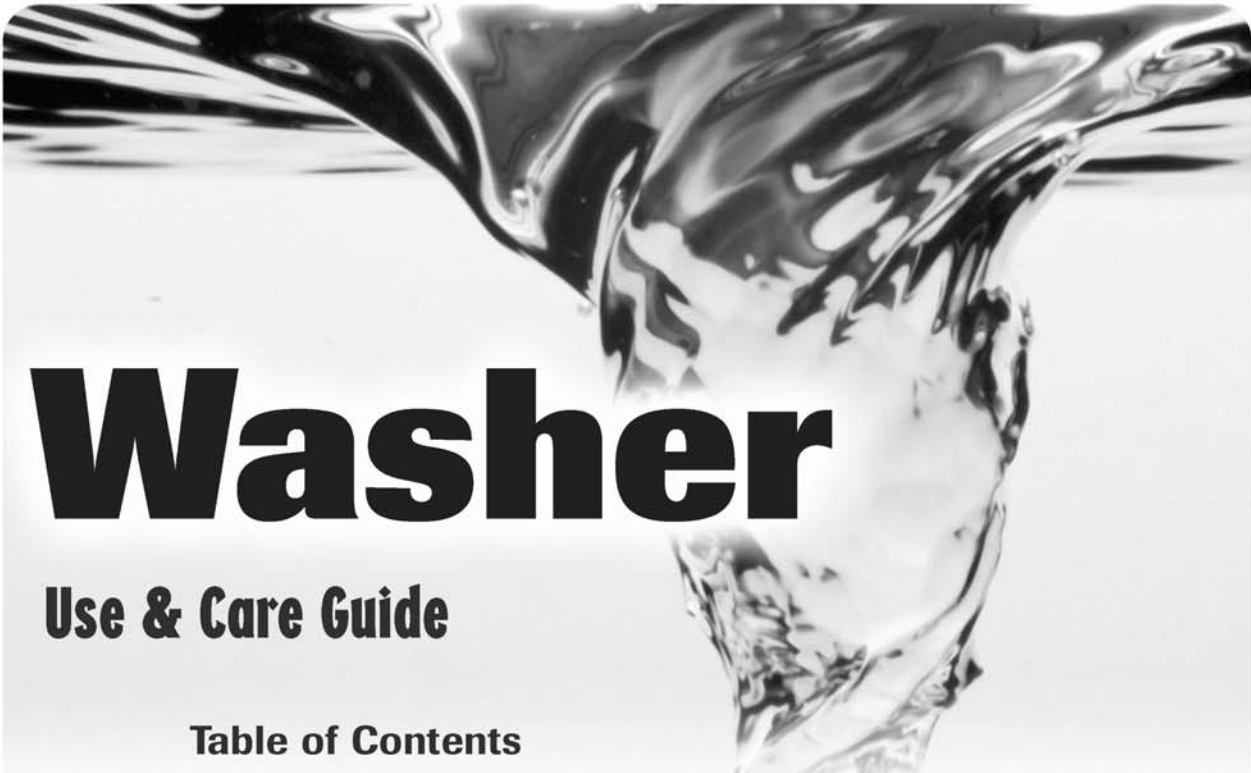

Washer

Use & Care Guide

Table of Contents



Important Safety Instructions 1-2



Operating Instructions 3

Load the Clothes Washer
Start the Washer
Water Use



Using the Controls 4-6

Turn the Washer On
Select the Cycle
Select Wash/Rinse Temperature
Select Spin Speed
Select Soil Level
Select Cycle Options
Changing a Cycle
Canceling a Cycle
Cycle Indicator Lights



Features 7-8

Automatic Dispenser
Detergent Compartment
Bleach Compartment
Fabric Softener Compartment



Care & Cleaning 9-10

Cleaning the Interior
Cleaning the Automatic Dispenser
Storing the Washer



Troubleshooting 11-13

Information Codes



Service & Warranty 15

**Guide d'utilisation
et d'entretien** 16

Guía de uso y cuidado 32



Important Safety Instructions

Installer: Please leave this manual with this appliance.

Consumer: Please read and keep this manual for future reference. Keep sales receipt and/or canceled check as proof of purchase.

Model Number _____

Serial Number _____

Date of Purchase _____

If you have questions, call:

Maytag Customer Assistance
1-800-688-9900 U.S.A.
1-800-688-2002 Canada
(Mon.-Fri., 8am-8pm Eastern Time)
Internet: <http://www.maytag.com>

U.S. Customers using TTY for deaf, hearing impaired or speech impaired, call 1-800-688-2080.

In our continuing effort to improve the quality and performance of our appliances, it may be necessary to make changes to the appliance without revising this guide.

For service information, see page 15.

What You Need to Know About Safety Instructions

Warning and Important Safety Instructions appearing in this manual are not meant to cover all possible conditions and situations that may occur. Common sense, caution and care must be exercised when installing, maintaining or operating appliance.

Always contact your dealer, distributor, service agent or manufacturer about problems or conditions you do not understand.

Recognize Safety Symbols, Words, Labels

WARNING

WARNING – Hazards or unsafe practices which **COULD** result in severe personal injury or death.

CAUTION

CAUTION – Hazards or unsafe practices which **COULD** result in minor personal injury.

WARNING

To reduce the risk of fire, explosion, electric shock, or personal injury when using your washer, follow basic safety precautions, including the following:

1. Read all instructions before using the appliance.
2. As with any equipment using electricity and having moving parts, there are potential hazards. To use this appliance safely, the operator should become familiar with the instructions for operation of the appliance and always exercise care when using it.
3. Do not install or store this appliance where it will be exposed to the weather.
4. Install and level the clothes washer on a floor that can support the weight.
5. This appliance must be properly grounded. Never plug the appliance cord into a receptacle which is not grounded adequately and in accordance with local and national codes. See installation instructions for grounding this appliance.
6. To avoid the possibility of fire or explosion:
 - Do not wash items that have been previously cleaned in, washed in, soaked in, or spotted with gasoline, dry-cleaning solvents, or other flammable or explosive substances as they give off vapors that could ignite or explode. Hand wash and line dry any items containing these substances.

Any material on which you have used a cleaning solvent, or which is saturated with flammable liquids or solids, should not be placed in the clothes washer until all traces of these liquids or solids and their fumes have been removed.

These items include acetone, denatured alcohol, gasoline, kerosene, some liquid household cleaners, some spot removers, turpentine, waxes and wax removers.

- Do not add gasoline, dry-cleaning solvents, or other flammable or explosive substances to the wash water. These substances give off vapors that could ignite or explode.
- Under certain conditions, hydrogen gas may be produced in a hot water system that has not been used for 2 weeks or more. **HYDROGEN GAS IS EXPLOSIVE.** If the hot water system has not been used for such a period, before using a



Important Safety Instructions

washing machine or combination washer-dryer, turn on all hot water faucets and let the water flow from each for several minutes. This will release any accumulated hydrogen gas. As the gas is flammable, do not smoke or use an open flame during this time.

7. Unplug power supply cord before attempting to service your clothes washer.
8. Do not reach into the appliance if the tumbler is moving.
9. Do not allow children to play on or in the appliance. Close supervision of children is necessary when the appliance is used near children.
10. Do not tamper with controls.
11. Do not repair or replace any part of the appliance or attempt any servicing unless specifically recommended in published user-repair instructions that you understand and have the skills to carry out.
12. Store laundry aids and other material in a cool, dry place where children cannot reach them.
13. Do not wash or dry items that are soiled with vegetable or cooking oil. These items may contain some oil after laundering. Due to the remaining oil, the fabric may smoke or catch fire by itself.
14. Do not use chlorine bleach and ammonia or acids (such as vinegar or rust remover) in the same wash. Hazardous fumes can form.
15. Do not machine wash fiberglass materials. Small particles can stick to fabrics washed in following loads and cause skin irritation.
16. Before the appliance is removed from service or discarded, remove the door to the washing compartment.
17. Do not sit on top of the clothes washer.
18. Inlet hoses are subject to damage and deterioration over time. Check the hoses periodically for bulges, kinks, cuts, wear or leaks and replace them every five years.

SAVE THESE INSTRUCTIONS



Operating Instructions

IMPORTANT

- Before washing clothes for the first time, a complete cycle must be run without a load. This will remove any water remaining in the washer from the manufacturer's test run.

Load the Clothes Washer

- The tub can be loaded completely full with dry, unfolded clothes. However, DO NOT pack the tub tightly.
- Overloading may reduce washing efficiency, cause excess wear and possibly cause creasing or wrinkling of the load.
- Wash delicate items such as bras, hosiery and other lingerie in the "Delicates" or "Handwash" cycle with similar lightweight items.
- When washing smaller, bulky items that do not fill the tub completely such as a rug, one pillow, stuffed toys or one or two sweaters, a few towels should be added for improved tumbling and spin performance.
- When washing heavily soiled loads, it is very important to *avoid overloading* the washer to assure good cleaning results.
- To add a forgotten item in the Normal, Colors, Heavy Duty or Quick Wash cycles, press **Start/Pause**, wait for the Door Lock light to go out, add the item, close the door and press **Start/Pause**. After a pause of one to two minutes, the cycle will resume.
- Close door carefully to avoid slamming.

Note

- To ensure that your additional items get clean, do not wait more than five minutes after the cycle has started to add the items.

Start the Washer

1. Press any pad or turn the cycle selector dial.
2. Load the washer loosely – DO NOT overload.
3. Close the door.
4. Add detergent and additives to the dispenser (see pages 7-8).
5. Select the appropriate cycle and options for the load, (see pages 4-6).
6. Press the **Start/Pause** pad. 
7. The Wash indicator light will illuminate.
8. The estimated cycle time will appear in the display. The time may fluctuate to better indicate the wash time remaining in the cycle.

Notes

- When the cycle is complete, the Door Lock light will go out and "End" will appear in the display after one to two minutes.
- DO NOT attempt to open the door until the Door Lock light is off. To add a forgotten item, see Load The Clothes Washer section.
- When the washer is restarted after a pause, there will be a pause of up to 15 seconds before the cycle will continue.
- Pressing **Power Off** cancels the cycle and stops the washer.
- The Wash, Rinse and Spin indicator lights will illuminate during those portions of the cycle.

Water Use

The amount of water used will vary with each load. The washer will automatically provide the appropriate amount of water for efficient cleaning performance and conservation of water and energy. Fill time will vary depending on water pressure.



Using the Controls

STEP 1

Turn the Washer On

Press any pad or turn the cycle selector knob to turn the washer on. Press the **Power Off** pad to turn the washer off.

If the washer power is left on for longer than 10 minutes without starting the washer, the power automatically turns off.



STEP 2

Select Cycle

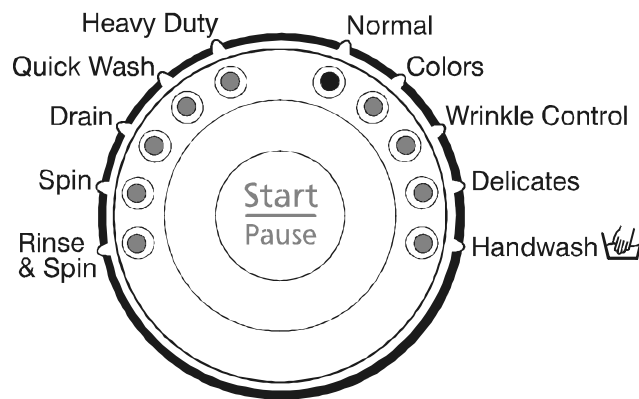

Turn the cycle selector dial to select the appropriate cycle for your load. The indicator light by the cycle name will illuminate.

- **Rinse & Spin** – For all fabrics needing a rinse and spin only.
- **Spin** – For all fabrics and garments needing a spin only.
- **Drain** – To drain water from tub without spinning.
- **Quick Wash** – For lightly soiled or wrinkled garments needed quickly. For best results, use *liquid* detergent.
- **Heavy Duty** – For sturdy, colorfast fabrics and heavily soiled garments.

- **Normal** – For most fabrics including cottons, linens and normally soiled garments.
- **Colors** – For bright fabrics or fabrics that may bleed.
- **Wrinkle Control** – For “wash and wear” and synthetic fabrics and lightly to normally soiled garments.
- **Delicates** – For sheer fabrics, bras and lingerie.
- **Handwash** – For wool, silk and other hand-wash-only fabrics. For best results, use *liquid* detergent.

Note

- To minimize wrinkling of loads, select the **Wrinkle Control** cycle.



Using the Controls

STEP 3

Select Wash/Rinse Temperature

Press the **Temperature** pad to select the wash and rinse temperatures. The light next to the temperature will illuminate. Press the pad repeatedly to scroll through the temperature settings.

Hot/Cold – Whites and heavily soiled color-fast items.

ATC Warm/Warm – Color-fast items. When warm rinse is selected, only the final rinse will be warm. The other rinses will be cold to conserve energy.

ATC Warm/Cold – Moderately soiled, color-fast items; most wrinkle free items

ATC Cold/Cold – Brightly colored, lightly soiled items

Cold/Cold – Brightly colored, very lightly soiled items; washable woolens

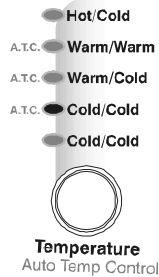

IMPORTANT

- The washer features an automatic temperature control (ATC) to provide a warm wash of approximately 105° F, a warm rinse of approximately 80° F and cold wash of approximately 65° F on the ATC temperature selections.

REMEMBER: In wash water temperatures below 60° F, detergents do not dissolve well or clean well.

STEP 4

Select Spin Speed

Press the **Spin** pad to select the appropriate spin speed for the load. The light next to the spin speed will illuminate. Press the pad repeatedly to scroll through the spin speed settings.

High – Use for underwear, t-shirts and sturdy cottons.

Medium – Use for jeans, wrinkle free or “wash-and-wear” items and synthetics.

Low – Use for delicate items needing a slow spin speed because of fabric and construction and for hang-dry items.

No Spin – Drains the washer without spinning. Use for extremely delicate items that cannot tolerate any spin.



STEP 5

Select Soil Level

Press the **Soil Level** pad to select the appropriate soil level for the load. The light next to the **Soil Level** pad will illuminate. Press the pad repeatedly to scroll through the soil level settings.

Heavy – Use for cleaning heavily soiled loads.

Normal – Use for cleaning moderately soiled loads. This setting will be appropriate for most loads.

Light – Use for cleaning lightly soiled loads.

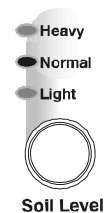



Using the Controls

STEP 6

Select Cycle Options

Press the pads to select one or more options.

Extra Rinse

Adds an additional rinse at the end of the cycle to more thoroughly remove laundry additives and perfumes.

Chime

Press the **Chime** pad to activate audio Power on, start and end-of-cycle signals.

Delay Start

Any cycle can be delayed for up to 19 hours in *one hour increments*.

1. Make the appropriate selections for your load.
2. Press the **Delay Start** pad until the desired delay time appears in the display.
3. Press the **Start/Pause** pad. The delay time will start counting down.
4. To cancel a delay, press **Start/Pause** and reselect the cycle.

Child Lock

The washer controls can be locked to prevent unwanted use by children.

1. Press the **Chime** and **Delay Start** pads at the same time for three seconds.
2. The Child Lock light will illuminate.
3. To unlock, press the **Chime** and **Delay Start** pads at the same time for three seconds. The Child Lock light will go out.

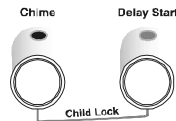

STEP 7

Start the Washer

To start the washer, press the **Start/Pause** Pad.



Changing a Cycle

If an incorrect cycle has been accidentally selected:

1. Press the **Start/Pause** pad.
2. Turn the Cycle selector dial to the desired cycle.
3. Set the desired options for the cycle.
4. Press the **Start/Pause** pad. The Wash indicator lights stops flashing and the new cycle starts.



Canceling a Cycle

To cancel a cycle:

1. Press the **Power Off** pad.
2. Turn the Cycle selector dial to **Drain** or **Spin**.
3. Press the **Start/Pause** pad. The Spin light illuminates and the washer starts the drain or spin.



Cycle Indicator Lights



The Wash, Rinse and Spin lights at the top of the control panel will illuminate progressively to indicate when the washer is in those portions of the cycle.

The Washer light will flash when the cycle has been paused.

Features

Your Maytag washer is designed to use high efficiency (HE) detergents.

Detergent

- For best cleaning results, use a high efficiency detergent such as Tide HE, Cheer HE or Wisk HE*. High efficiency detergents contain suds suppressors which reduce or eliminate suds. When less suds are produced, the load tumbles more efficiently and cleaning results are maximized.
 - When using regular detergent formulated for top-loading washers, it is important to pay close attention to the soil level of the load, load size, and water hardness**. **To avoid over-sudsing which causes extended cycle times, reduce the amount of detergent used with soft water or with small or lightly soiled clothes.**
- * Brand names are trademarks of the respective manufacturers.
- ** To determine water hardness in your area, contact your local water utility or State University Extension office in your area.



Automatic Dispenser

The washer has separate compartments for dispensing detergent and color-safe bleach, chlorine bleach and fabric softener. All laundry additives are added to their respective compartments before starting the washer.

The Automatic Dispenser MUST ALWAYS be in place before starting the washer. DO NOT open the Automatic Dispenser when the washer is running.

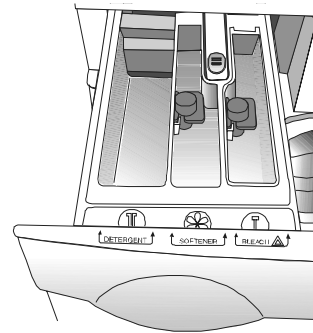

To use:

1. Pull out the dispenser drawer on the left side of the control panel.
2. Fill appropriate compartments with laundry additives, being careful not to *overflow* or *spill* additives.
3. Slide the dispenser drawer carefully and completely back into the compartment.

Detergent Compartment

1. Pour the recommended amount of laundry detergent directly into the detergent compartment *before* starting the washer.
 2. If color-safe bleach is to be used, it should be added *with* detergent to the detergent compartment.
- When adding color-safe bleach with detergent, it is best if both laundry products are in the same form; granular or liquid.

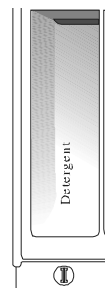

Features

Bleach Compartment

(Liquid Chlorine Bleach Only)

1. Add chlorine bleach to the bleach compartment. **DO NOT** exceed the fill line.
2. Avoid splashing or over-filling the compartment.
3. The washer automatically dispenses bleach into the tub at the appropriate time.
4. The dispenser automatically dilutes liquid chlorine bleach *before* it reaches the wash load.

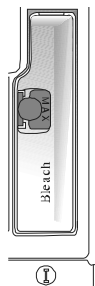

Notes

- **Never pour undiluted liquid chlorine bleach directly onto the load or into the tub.** It is a powerful chemical and can cause fabric damage, such as weakening of the fibers or color loss if not used properly.
- If you prefer to use color-safe non-chlorine bleach, add it to the detergent compartment. **Do not pour color-safe bleach into the bleach compartment.**

Fabric Softener Compartment

1. Pour the recommended amount of liquid fabric softener into the softener compartment. For smaller loads, *use less than one cap full.*
2. Fabric softener should be diluted with warm water until it reaches the **MAX FILL** line on the compartment.
3. The dispenser automatically releases liquid fabric softener at the proper time during the rinse cycle.



Notes

- Use the softener compartment **ONLY** for liquid fabric softeners.
- Using the Downy Ball* is not recommended with this washer. It will not add fabric softener at the appropriate time. Use the automatic dispenser.

* Brand names are trademarks of the respective manufacturers.



Care & Cleaning

Turn off the water faucets after finishing the day's washing. This will shut off the water supply to the clothes washer and prevent the unlikely possibility of damage from escaping water. Leave the door open to allow the inside of the washer to dry out.

Use a soft cloth to wipe up all detergent, bleach or other spills as they occur.

Clean the following as recommended:

Control Panel – clean with a soft, damp cloth. Do not use abrasive powders or cleaning pads. Do not spray cleaners directly on the panel.

Cabinet – clean with soap and water.

Cleaning the Interior

Clean the interior of the washer periodically to remove any dirt, soil, odor, mold, mildew or bacteria residue that may remain in the washer as a result of washing clothes. We recommend taking the following steps every 60 to 120 days to clean and freshen your washer interior. The frequency with which the washer should be cleaned and freshened depends on factors such as usage, the amount of dirt, soil or bacteria being run through your washer, or the use of cold water. Failure to follow these instructions may result in unsatisfactory conditions, including unpleasant odor and/or permanent stains on the washer or washload.

To clean and freshen the washer interior:

1. Make a solution of one cup chlorine bleach and two cups warm water. Be careful not to spill or splash the bleach solution.
2. Wipe the door seal with bleach solution and a soft cloth.
3. Fill bleach dispenser with chlorine bleach.
4. Run the washer through a complete cycle using hot water.
5. Repeat the wash cycle if necessary.

Hard water deposits may be removed, if needed. Use a recommended cleaner labeled clothes washer safe.



Care & Cleaning

Cleaning the Automatic Dispenser and Compartment

The Automatic Dispenser may need to be cleaned periodically due to laundry additive buildup.

1. Press the release lever on the inside of the dispenser and pull out.

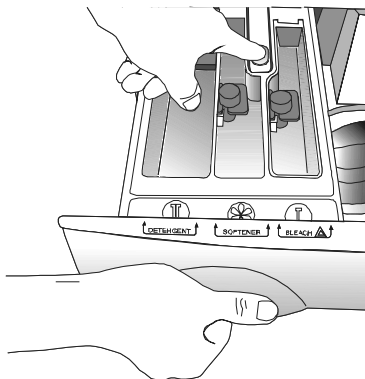

2. Remove the cups from the fabric softener and bleach compartments.
3. Wash all of the parts under running water.
4. Clean the dispenser recess with a soft brush.
5. Reinsert the cups, pushing them firmly into place.
6. Push the dispenser back into place.
7. Run a Rinse & Spin cycle without any load in the washer.

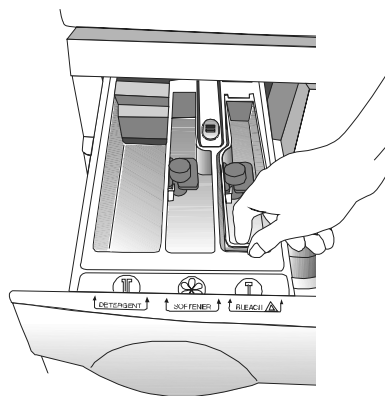

Storing the Clothes Washer

Washers can be damaged if water is not removed from hoses and internal components before storage. Prepare the washer for storage as follows:

- Select the Quick Wash cycle and add bleach to the automatic dispenser. Run the washer through the cycle without a load.
- Turn the water faucets off and disconnect the inlet hoses.
- Disconnect the clothes washer from the electrical supply and leave the washer door *open* to let air circulate inside the tumbler.
- If the washer has been stored in below-freezing temperatures, allow time for any water left over in the washer to thaw out prior to use.

For information on long-term storage or storage of your washer during extreme cold temperatures, call Maytag Customer Service toll-free at 1-800-688-9900 USA or 1-800-688-2002 Canada. U.S. customers using TTY for deaf, hearing impaired or speech impaired, call 1-800-688-2080.

Troubleshooting

Information codes may be displayed to help you better understand what is occurring with the washer.

Code Symbol	Meaning	Solution
dc	Unbalanced load prevented the washer from spinning.	Redistribute the load, press Start/Pause .
dl	Door lock is open when washer is running.	Press Power Off pad then restart the cycle. If the code reappears, call for service, see below.
FL	The washer failed to lock the door.	Close the door tightly and restart the cycle.
H-	Water temperature control problem.	Call for service, see below.
LE	The washer has tried to fill but has not reached the proper water level.	Call for service, see below.
LO	The door will not unlock.	Make sure the door is firmly closed. Push the Power Off pad and wait two minutes for the door to unlock. OR Unplug the washer for two minutes and plug back in.
L-	Motor not running properly.	Call for service, see below.
nd	The washer is not draining.	See Troubleshooting "The washer does not drain and/or spin", page 13. If problem continues, call for service, see below.
nf	The washer has tried to fill but was unsuccessful.	Make sure the water faucets are open all the way. Check for kinked hoses. Check inlet screens on fill hoses.
S-	Problem with control.	Call for service, see below.

For any codes not listed above, call Maytag Customer Service at 1-800-688-9900 USA or 1-800-688-2002 Canada.

Troubleshooting

<p>The washer will not start</p>	<ul style="list-style-type: none"> • Make sure door is firmly closed. • Make sure the washer is plugged in. • Make sure the water source faucet is turned on. • Make sure to press the Start/Pause pad. • Make sure the Child Lock is not activated, see page 6.
<p>No water or insufficient water supply</p>	<ul style="list-style-type: none"> • Turn both faucets on fully. • Make sure the door is tightly closed. • Make sure the washer is plugged in. • Check fuse or reset circuit breaker. • Press the Start/Pause pad. • Straighten water inlet hoses. • Disconnect hoses and clean screens. Hose filter screens may be plugged. • Open and close the door, then press the Start/Pause pad.
<p>Detergent remains in the automatic dispenser after the wash cycle is complete</p>	<ul style="list-style-type: none"> • Make sure the washer is running with sufficient water pressure. See Installation Instructions. • Put the detergent in the inner parts of the dispenser (away from outside edges).
<p>Washer vibrates or is too noisy</p>	<ul style="list-style-type: none"> • Make sure the washer is set on a level surface. If the surface is not level, adjust the washer feet to level the appliance. See Installation Instructions. • Make sure that the shipping bolts are removed. See Installation Instructions. • Make sure the washer is not touching any other object. • Make sure the laundry load is balanced.
<p>Stops</p>	<ul style="list-style-type: none"> • Plug cord into live electrical outlet. • Check fuse or reset circuit breaker. • Close door and push the Start/Pause pad to start the washer. For your safety, the washer will not tumble or spin unless the door is closed. • This may be a pause or soak period in the cycle. Wait briefly and it may start. • Check screens on inlet hoses at the faucets for obstructions. Clean screens periodically.

Continued...

Troubleshooting

<p>Fills with the wrong temperature water</p>	<ul style="list-style-type: none"> • Turn both faucets on fully. • Make sure temperature selection is correct. • Make sure hoses are connected to correct faucets. Flush water lines. • Check the water heater. It should be set to deliver a minimum 120°F (49°C) hot water at the tap. Also check water heater capacity and recovery rate. • Disconnect hoses and clean screens. Hose filter screens may be plugged. • As the washer is filling, the water temperature may change as the automatic temperature control feature checks incoming water temperature. This is normal. • While the washer is filling, you may notice just hot and/or just cold water going through the dispenser when cold or warm wash temperatures are selected. This is a normal function of the automatic temperature control feature as the washer determines the temperature of the water.
<p>Won't tumble</p>	<ul style="list-style-type: none"> • Check fuse or reset circuit breaker. • Close the door and press the Start/Pause pad. For your safety, the washer will not tumble or spin unless the door is closed.
<p>Door locked shut; will not open</p>	<ul style="list-style-type: none"> • Press the Start/Pause pad to stop the machine. • It may take a few moments for the door lock mechanism to disengage.
<p>Freshening your washer</p>	<ul style="list-style-type: none"> • See Cleaning the Interior, page 9.
<p>The washer does not drain and/or spin</p>	<ul style="list-style-type: none"> • Check fuse or reset circuit breaker. • Straighten drain hoses. Eliminate kinked hoses. If there is a drain restriction, call for service. • Close the door and press the Start/Pause pad. For your safety, the washer will not tumble or spin unless the door is closed.
<p>Load is too wet at end of cycle</p>	<ul style="list-style-type: none"> • Use the High spin speed. • Use high efficiency detergent to reduce over-sudsing. • Load is too small. Very small loads (one or two items) may become unbalanced and not spin out completely.
<p>Leaks Water</p>	<ul style="list-style-type: none"> • Make sure door is firmly closed. • Make sure hose connections are tight. • Make sure end of drain hose is correctly inserted and secured to drain facility. • Avoid overloading. • Use high efficiency detergent to prevent over-sudsing.

For further assistance, call Maytag Customer Service toll-free at 1-800-688-9900 USA or 1-800-688-2002 Canada.
 U.S. customers using TTY for deaf, hearing impaired or speech impaired, call 1-800-688-2080.



Notes



Service & Warranty

Washer Warranty

Full One-Year Warranty

For one (1) year from the date of original retail purchase, any part with fails in normal home use will be repaired or replaced free of charge.

Limited Warranty

After the first year from the date of original retail purchase, through the time periods listed below, the parts designated below which fail in normal home use will be repaired or replaced free of charge for the part itself, with the owner paying all other costs including labor, mileage, transportation, trip charge and diagnostic charge, if required.

Second Year – All parts.

Third Through Fifth Year – Drive motor.

Third Through Lifetime – Stainless steel inner wash basket.

Additional Limited Warranty Against Rust-Through –

Should an exterior cabinet, including the top and base frame, rust through during the one year period starting from the date of retail purchase, repair or replacement will be made free of charge. After the first, and through the fifth year, repair or replacement will be made free of charge for the part itself, with the owner paying all other costs, including labor, mileage, transportation, trip charge and diagnostic charge, if required.

Please Note: This full warranty and the limited warranty apply when the washer is located in the United States or Canada. Washers located elsewhere are covered by the limited warranty only, including parts which fail during the first two years.

Canadian Residents

This warranty covers only those appliances installed in Canada that have been listed with the Canadian Standards Association unless the appliances are brought into Canada due to transfer of residence from the United States to Canada.

The specific warranties expressed above are the **ONLY** warranties provided by the manufacturer. This warranty gives you specific legal rights, and you may also have other rights that vary from state to state.

Use & Care Guides, service manuals and parts catalogs are available from Maytag ServicesSM, Maytag Customer Assistance.

What is Not Covered By These Warranties:

1. Conditions and damages resulting from any of the following:
 - a. Improper installation, delivery or maintenance.
 - b. Any repair, modification, alteration, or adjustment not authorized by the manufacturer or an authorized servicer.
 - c. Misuse, abuse, accidents or unreasonable use.
 - d. Incorrect electric current, voltage or supply.
 - e. Improper setting of any control.
2. Warranties are void if the original serial numbers have been removed, altered or cannot be readily determined.
3. Products purchased for commercial or industrial use.
4. The cost of service or service call to:
 - a. Correct installation errors.
 - b. Instruct the user on the proper use of the product.
 - c. Transport the appliance to the servicer.
5. Consequential or incidental damages sustained by any person as a result of any breach of these warranties.

Some states do not allow the exclusion or limitation of consequential or incidental damages, so the above exclusion may not apply.

To Obtain Warranty Service

To locate an authorized service company in your area, contact the dealer from whom your appliance was purchased; or call Maytag ServicesSM, Maytag Customer Assistance. Should you not receive satisfactory warranty service, please call or write:

Maytag ServicesSM
 Attn: CAIR[®] Center
 P.O. Box 2370
 Cleveland, TN 37320-2370
U.S. 1-800-688-9900
Canada 1-800-688-2002
U.S. Customers using TTY for deaf, hearing impaired or speech impaired, call 1-800-688-2080.

Note

- When contacting Maytag ServicesSM, Maytag Customer Assistance about a service problem, please include the following:
 - a. Your name, address and telephone number;
 - b. Model number and serial number (found on the back center of the control panel) of your appliance;
 - c. Name and address of your dealer and the date the appliance was purchased;
 - d. A clear description of the problem you are having;
 - e. Proof of purchase.