

ML-3



TECHNICAL EDUCATION

**CENTENNIAL™
TOP-LOAD WASHER**



**MODELS: MTW5900TW0 MTW5800TW0
 MTW5700TW0 MTW5600TW0
 MTW5500TW0**

JOB AID 8178628

FORWARD

This Maytag Job Aid, “Centennial™ Top-Load Washer” (Part No. 8178628), provides the In-Home Service Professional with information on the installation, operation, and service of the Centennial™ Top-Load Washer. For specific information on the model being serviced, refer to the “Use and Care Guide,” or “Tech Sheet” provided with the washer.

The Wiring Diagram used in this Job Aid is typical and should be used for training purposes only. Always use the Wiring Diagram supplied with the product when servicing the washer.

GOALS AND OBJECTIVES

The goal of this Job Aid is to provide information that will enable the In-Home Service Professional to properly diagnose malfunctions and repair the Centennial™ Top-Load Washer.

The objectives of this Job Aid are to:

- Understand and follow proper safety precautions.
- Successfully troubleshoot and diagnose malfunctions.
- Successfully perform necessary repairs.
- Successfully return the washer to its proper operational status.

WHIRLPOOL CORPORATION assumes no responsibility for any repairs made on our products by anyone other than authorized In-Home Service Professionals.

TABLE OF CONTENTS

	Page
GENERAL	1-1
Washer Safety	1-1
Model & Serial Number Designations	1-2
Model & Serial Number Label And Tech Sheet Locations	1-3
Specifications	1-4
INSTALLATION INFORMATION	2-1
Installation Requirements	2-1
Installation Instructions	2-5
PRODUCT OPERATION	3-1
Washer Use	3-1
Washer Care	3-4
Troubleshooting	3-5
COMPONENT ACCESS	4-1
Component Locations	4-1
Removing The Console Components And The Power Supply Cord	4-2
Removing The Lid Switch	4-4
Removing The Bleach Dispenser Wax Motor	4-5
Removing The Rear Panel Components	4-7
Removing The Pump And Motor	4-10
Removing The Agitator And Transmission	4-12
Removing The Basket, Outer Tub, And Basket Drive Assembly	4-16
Removing The Skate Plate And Suspension Pads	4-19
COMPONENT TESTING	5-1
Timer Motor	5-1
Lid Switch (N.O.)	5-1
Water Level Pressure Switch	5-2
Water Inlet/ATC Sensor	5-3
Motor Start Capacitor	5-4
Motor	5-5
Motor Thermal Protector	5-6
Basket Drive Shaft Checks	5-6
DIAGRAMS AND CHARTS	6-1
Wiring Diagram	6-1
Timer Sequence Chart	6-2
Cycle Charts	6-3

— NOTES —

GENERAL WASHER SAFETY

Your safety and the safety of others are very important.

We have provided many important safety messages in this manual and on your appliance. Always read and obey all safety messages.



This is the safety alert symbol.

This symbol alerts you to potential hazards that can kill or hurt you and others.

All safety messages will follow the safety alert symbol and either the word “DANGER” or “WARNING.” These words mean:

! DANGER

You can be killed or seriously injured if you don't immediately follow instructions.

! WARNING

You can be killed or seriously injured if you don't follow instructions.

All safety messages will tell you what the potential hazard is, tell you how to reduce the chance of injury, and tell you what can happen if the instructions are not followed.

MODEL & SERIAL NUMBER DESIGNATIONS

MODEL NUMBER

MODEL NUMBER	M	T	W	5	9	00	T	W	0
BRAND M = Maytag									
ACCESS / FUEL T = Top Load G = Gas F = Front Load H = Horizontal W = Work Space V = Vertical E = Electric									
PRODUCT W = Washer P = Pedestal D = Dryer B = Combo T = Thin Twin C = Compact									
SERIES 1 = Innovation 6 = Oasis 2 = Commercial 7 = Merloni 3 = Compact 8 = Horizon 4 = Stack 9 = Duet/Combo 5 = LEAP									
PRICE POINT LEVELS (1 - 9)									
TRADE PARTNER 00 = Brand 30 = NATM 10 = SBC 40 = Lowe's 20 = Best Buy									
YEAR OF INTRODUCTION T = 2007									
COLOR CODE W = Silver Metallic - on - White Q = White-on-White									
ENGINEERING CHANGE 0 = Basic Original Release 1 = First Revision									

SERIAL NUMBER

SERIAL NUMBER	C	U	41	10200
MANUFACTURING SITE C = Clyde, OH				
YEAR OF PRODUCTION U = 2007				
WEEK OF PRODUCTION 41 = 41st Week				
PRODUCT SEQUENCE NUMBER				

MODEL & SERIAL NUMBER LABEL AND TECH SHEET LOCATIONS

The Model & Serial Number Label and Tech Sheet locations are shown below.

Model & Serial Number Label



Tech Sheet (Behind Console)

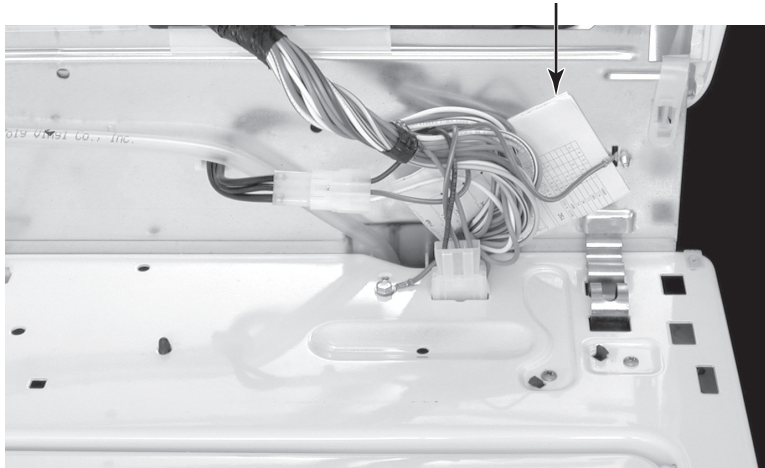

SPECIFICATIONS

Model	MTW5900T	MTW5800T	MTW5700T	MTW5600T	MTW5500T
Capacity (cu. ft.)	3.2	3.2	3.2	3.2	3.2
Automatic Temperature Control	•	•	•	•	•
Commercial-Grade Transmission	•	•	•	•	•
Preselected Spin Speed	•	•	•	•	•
High-Flow Pump	•	•	•	•	•
FlexCare™ Agitator	•	•	•	•	•
100° Arc Of Agitation	•	•	•	•	•
Bleach & Fabric Softener Dispenser	•	•	•	•	•
PureClean™ Rinse System	•	•	•	•	•
Extra Rinse Option	•	•	•		
SpinSpray™ Rinse	•	•	•	•	•
Clean Deep Rinse	•	•	•	•	•
End-of-Cycle Signal	Adjustable	•	•	•	•
One-Piece Drain Hose	•	•	•	•	•
Wide-Opening Lid	•	•	•	•	•
Full-Width Lid Bumper	•	•	•	•	•
Spill Guard	•	•	•	•	•
Seamless Edges	•	•	•	•	•
Smooth Balance™ Suspension System	•	•	•	•	•
Commercial-Grade Steel-Reinforced Baseframe	•	•	•	•	•
Commercial-Grade Coupler	•	•	•	•	•
Front-Serviceable	•	•	•	•	•
Zinc-Coated Leveling Legs	•	•	•	•	•
Porcelain-On-Steel Wash Basket			•	•	•
Stainless Steel Wash Basket	•	•			
Porcelain-on-Steel Top	•	•	•	•	
Powdercoat-on-Steel					•
Temp Settings	4	4	4	4	3
Time-Release Bleach System	•				
Colors*	W	W	Q	Q	Q
Automatic Wash Cycles	MULT	10	9	6	6

* See "Color Code," page 1-2

INSTALLATION INFORMATION

INSTALLATION REQUIREMENTS

TOOLS AND PARTS

Gather the required tools and parts before starting installation. The parts supplied are in the washer basket.

Parts needed (not provided with washer):

- Inlet hoses
- Flat washers

To order:

- Call the dealer from whom you purchased your washer.
- Reference the toll-free number on the front page of the Use and Care Guide.
- Visit the website on the front page of the Use and Care Guide.

NOTE: Replace inlet hoses after 5 years of use to reduce the risk of hose failure. Record hose installation or replacement dates for future reference.

Parts supplied:

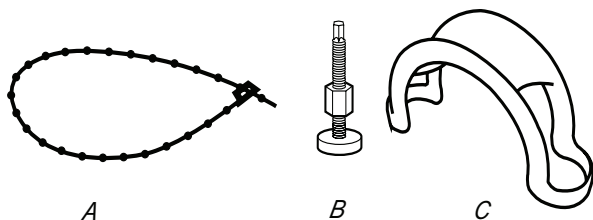

A. Beaded tie strap
 B. Front leveling feet with nuts (2)
 C. Drain hose form

Tools needed for installation:

- Adjustable or open end wrench 9/16" (14 mm)
- Level
- Wood block
- Ruler or measuring tape
- Pliers that open to 1-9/16" (3.95 cm)
- Flashlight (optional)

Alternate Parts

Your installation may require additional parts. For information on ordering, please refer to the toll-free phone numbers on the front page of the Use and Care Guide.

If You Have:	You Will Need to Buy:
Laundry tub or standpipe taller than 96 in. (2.4 m)	Sump pump system (if not already available)
1 in. (2.5 cm) diameter standpipe	1-1/4 in. (3.2 cm) diameter to 1 in. (2.5 cm) diameter standpipe adapter, Part No. 280130
Overhead sewer	Standard 20 gal. (76 L) 39 in. (99 cm) tall drain tub or utility sink, sump pump and connectors (available from local plumbing suppliers)
Floor drain	Siphon break kit, Part Number 280129, additional drain hose, Part Number 3357090
Water faucets beyond reach of fill hoses	2 longer water fill hoses: 6 ft (1.8 m) Part Number 76314, 10 ft (3.0 m) Part Number 350008
Drain hose too short	Kit Part No. 280131
Lint clogged drain	Drain protector, Part No. 367031

LOCATION REQUIREMENTS

Selecting the proper location for your washer improves performance and minimizes noise and possible washer “walk.”

Your washer can be installed in a basement, laundry room, closet, or recessed area (see “Drain System”).

IMPORTANT: Do not install or store the washer where it will be exposed to the weather.

Proper installation is your responsibility.

You will need:

- A water heater set to deliver 120°F (49°C) water to the washer.
- A grounded electrical outlet located within 4 ft. (1.2 m) of where the power cord is attached to the back of the washer (see “Electrical Requirements”).
- Hot and cold water faucets located within 3 ft. (90 cm) of the hot and cold water fill valves, and water pressure of 5-100 psi (34.5-690 kPa). Washers with triple dispensers require 20-100 psi (138-690 kPa) for best performance.
- A level floor with a maximum slope of 1” (2.5 cm) under entire washer. Installing the washer on carpeting is not recommended.
- A sturdy floor to support the washer weight (washer, water and load) of 315 lbs (143 kgs).

Do not store or operate your washer in temperatures at or below 32°F (0°C). Some water can remain in the washer and can cause damage in low temperatures (see “Washer Care”).

Recessed area or closet installation

The dimensions shown are for the recommended spacing allowed (A and B), except the closet door ventilation openings. The dimensions shown for the closet door ventilation openings (C) are the minimum required.

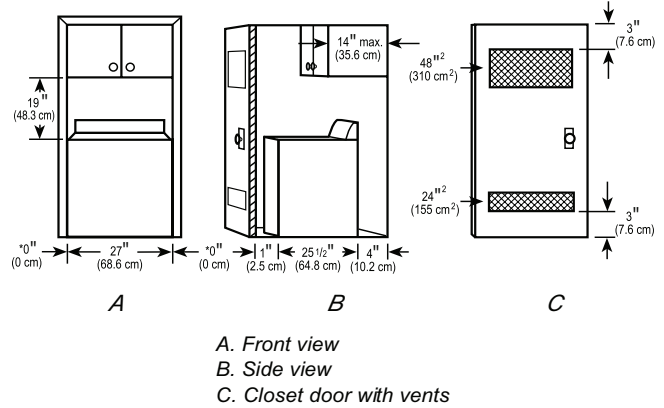

- Additional spacing should be considered for ease of installation and servicing.
- Additional clearances may be required for wall, door and floor moldings.
- Additional spacing of 1” (2.5 cm) on all sides of the washer is recommended to reduce noise transfer.
- If a closet door is installed, the minimum air openings in the top and bottom of the door are required (C). Louvered doors with air openings in the top and bottom are acceptable.
- Companion appliance spacing should also be considered.

DRAIN SYSTEM

The washer can be installed using the standpipe drain system (floor or wall), the laundry tub drain system, or the floor drain system. Select the drain hose installation method you need (see “Tools and Parts”).

Standpipe drain system - wall or floor (views A & B)

The standpipe drain requires a minimum diameter standpipe of 2" (5 cm). The minimum carry-away capacity can be no less than 17 gal. (64 L) per minute. A 1-1/4 in. (3.2 cm) diameter to 1" (2.5 cm) diameter standpipe adapter kit is available (see “Tools and Parts”).

The top of the standpipe must be at least 39" (99 cm) high and no higher than 96" (244 cm) from the bottom of the washer.

To avoid siphoning, no more than 8" (20.3 cm) of drain hose should be below the top of the washtub. Secure drain hose with beaded tie strap.

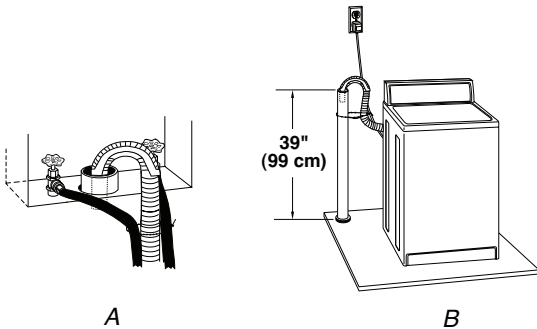

Laundry tub drain system (view C)

The laundry tub needs a minimum 20 gal. (76 L) capacity. The top of the laundry tub must be at least 39 in. (99 cm) above the floor and no higher than 96 in. (244 cm) from the bottom of the washer.

Floor drain system (view D)

The floor drain system requires a siphon break that may be purchased separately (see “Tools and Parts”).

The siphon break must be a minimum of 28 in. (71 cm) from the bottom of the washer. Additional hoses might be needed.

To avoid siphoning, no more than 8" (20.3 cm) of drain hose should be inside the standpipe. Secure drain hose with beaded tie strap.

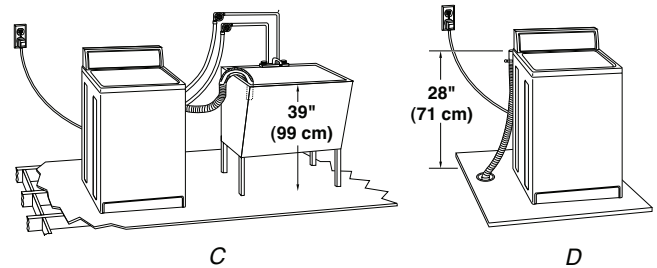

ELECTRICAL REQUIREMENTS

WARNING



Electrical Shock Hazard

Plug into a grounded 3 prong outlet.

Do not remove ground prong.

Do not use an adapter.

Do not use an extension cord.

Failure to follow these instructions can result in death, fire, or electrical shock.

- A 120-volt, 60-Hz., AC-only, 15 or 20-ampere, fused electrical supply is required. A time-delay fuse or circuit breaker is recommended. It is recommended that a separate circuit serving only this appliance be provided.
- This washer is equipped with a power supply cord having a 3 prong ground plug.
- To minimize possible shock hazard, the cord must be plugged into a mating, 3 prong, grounding-type outlet, grounded in accordance with local codes and ordinances. If a mating outlet is not available, it is the personal responsibility and obligation of the customer to have the properly grounded outlet installed by a qualified electrician.
- If codes permit and a separate ground wire is used, it is recommended that a qualified electrician determine that the ground path is adequate.
- Do not ground to a gas pipe.
- Check with a qualified electrician if you are not sure the washer is properly grounded.
- Do not have a fuse in the neutral or ground

GROUNDING INSTRUCTIONS

For a grounded, cord-connected washer:

This washer must be grounded. In the event of a malfunction or breakdown, grounding will reduce the risk of electrical shock by providing a path of least resistance for electric current. This washer is equipped with a cord having an equipment-grounding conductor and a grounding plug. The plug must be plugged into an appropriate outlet that is properly installed and grounded in accordance with all local codes and ordinances.

WARNING: Improper connection of the equipment-grounding conductor can result in a risk of electric shock. Check with a qualified electrician or serviceman if you are in doubt as to whether the appliance is properly grounded.

Do not modify the plug provided with the appliance – if it will not fit the outlet, have a proper outlet installed by a qualified electrician.

For a permanently connected washer:

This washer must be connected to a grounded metal, permanent wiring system, or an equipment-grounding conductor must be run with the circuit conductors and connected to the equipment-grounding terminal or lead on the appliance.

INSTALLATION INSTRUCTIONS

BEFORE YOU START

⚠ WARNING

Excessive Weight Hazard

Use two or more people to move and install washer.

Failure to do so can result in back or other injury.

NOTE: To avoid floor damage, set the washer onto cardboard before moving across floor.

REMOVE SHIPPING MATERIALS

Removing the shipping material is necessary for proper operation. If the shipping material is not removed, the washer will make excessive noise.

1. Move the washer to within approximately 3 ft (90 cm) of its final location.
2. The washer must be in the upright position and not tilted before removing the shipping material.
3. Locate the yellow shipping materials on the rear of the machine, near the bottom. Follow the steps for your particular model, either the one with the straight power cord and cord restraint or the looped power cord version.

Straight power cord

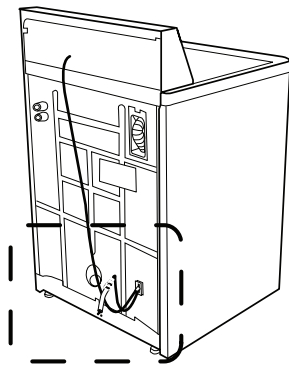

Straight power cord

1. Remove power plug and yellow strap from machine base to release the rear leveling system.

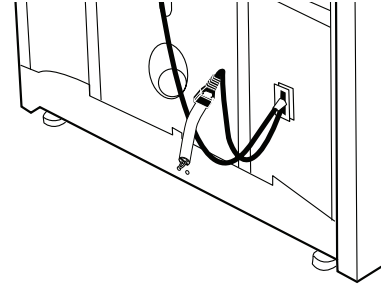

2. Firmly grasp the power cord and pull to completely remove the power cord, cord restraint, and pin from the rear panel.

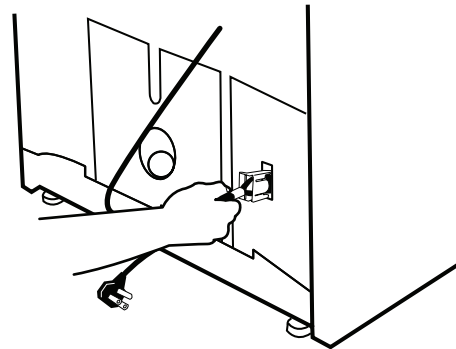

3. Confirm that the power cord restraint (A), and pin (B) are removed.

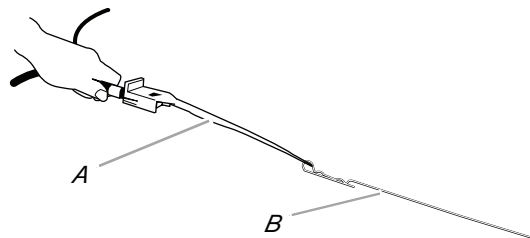

*A. Power cord restraint
B. Pin*

4. To remove the power cord from the cord restraint, push the power cord in, press TAB, and then pull the power cord out.

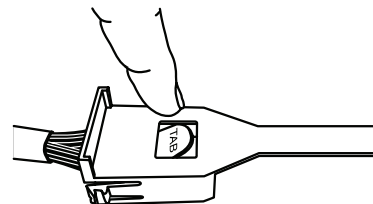

Looped power cord

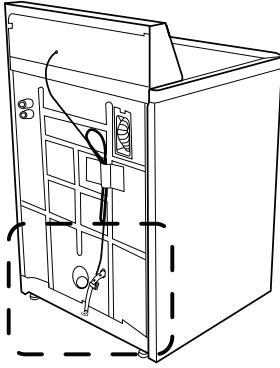

Looped power cord

1. Firmly grasp the yellow shipping strap and pull until both ends are completely removed from washer.

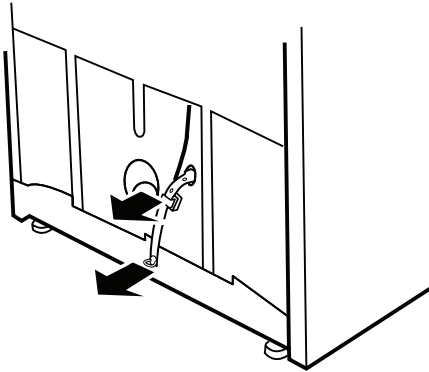

2. Check that two (2) cotter pins were removed with the shipping strap.

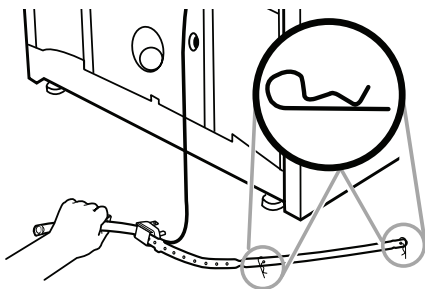

CONNECT DRAIN HOSE

Proper connection of the drain hose protects your floors from damage due to water leakage. Read and follow these instructions.

The drain hose is connected to your washer and is stored inside the washer cabinet.

Remove drain hose from washer cabinet

Gently pull the corrugated drain hose out of the washer from the top of the hose. Continue to pull the hose until the end emerges. Do not force excess drain hose back into the rear of the washer.

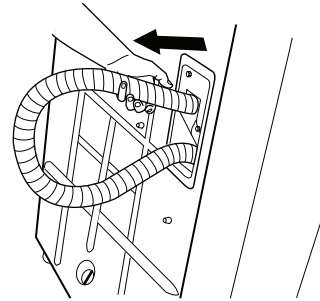

Laundry tub drain or standpipe drain

Connecting the drain hose form to the corrugated drain hose

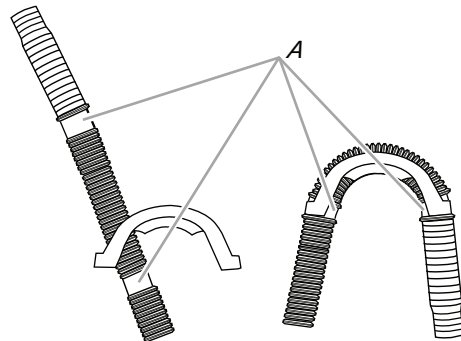

A. Drain hose reliefs

1. Feed end of drain hose into one end of form. Place end of drain hose form into the drain hose relief.
2. Bend the hose over the top of the form and feed into the other end of the form.

To keep drain water from going back into the washer:

- Do not force excess drain hose into standpipe. Hose should be secure but loose enough to provide a gap for air.
- Do not lay excess hose on the bottom of the laundry tub.

Floor drain

Do not install the drain hose form on to the corrugated drain hose. You may need additional parts. See Floor drain under “Tools and Parts.”

CONNECT THE INLET HOSES

The washer must be connected to the water faucets using new inlet hoses (not provided). Do not use old hoses.

Insert new flat washers into each end of the inlet hoses. Firmly seat the washers in the couplings.

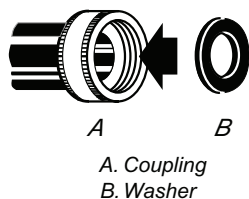

Connect the inlet hoses to the water faucets

Make sure the washer basket is empty.

1. Attach the hose to the hot water faucet. Screw on coupling by hand until it is seated on the washer.
2. Attach the hose to the cold water faucet. Screw on coupling by hand until it is seated on the washer.
3. Using pliers, tighten the couplings with an additional two-thirds turn.

NOTE: Do not overtighten or use tape or sealants on the valve. Damage to the valves can result.

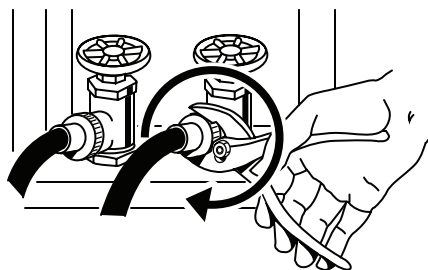

Clear the water lines

- Run water through both faucets and inlet hoses, into a bucket, drainpipe, or laundry tub, to get rid of particles in the water lines that might clog the inlet valve screens.
- Check the temperature of the water to make sure that the hot water hose is connected to the hot water faucet and that the cold water hose is connected to the cold water faucet.

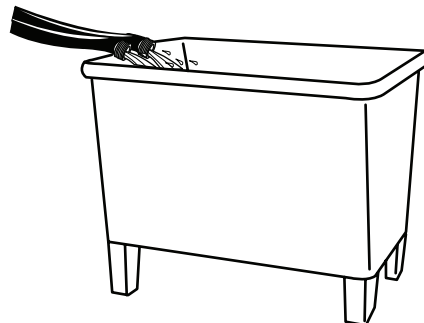

Connect the inlet hoses to the washer

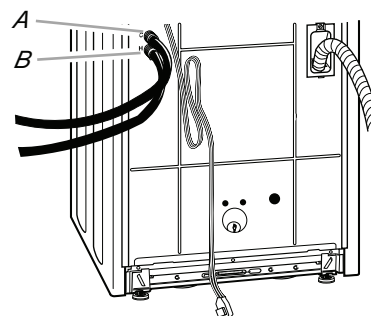

A. Cold water inlet valve
B. Hot water inlet valve

1. Attach the hot water hose to the bottom inlet valve.
2. Attaching the hot water coupling first makes it easier to tighten connection with pliers.
3. Screw on coupling by hand until it is seated on the washer.

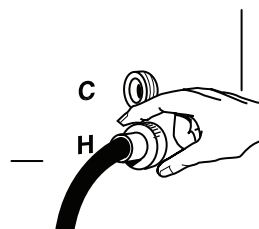

- Using pliers, tighten the couplings with an additional two-thirds turn.

NOTE: Do not overtighten or use tape or sealants on the valve. Damage to the valves can result.

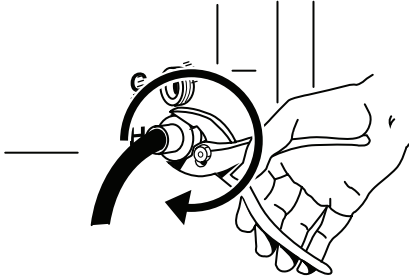

- Attach the cold water hose to the top inlet valve.
- Screw on coupling by hand until it is seated on the washer.
- Using pliers, tighten the couplings with an additional two-thirds turn.

NOTE: Do not overtighten or use tape or sealants on the valve. Damage to the valves can result.

Check for leaks

Turn on the water faucets and check for leaks. A small amount of water might enter the washer. You will drain this later.

NOTE: Replace inlet hoses after 5 years of use to reduce the risk of hose failure. Record hose installation or replacement dates for future reference.

- If you connect only one water hose, you must cap off the remaining water inlet port.
- Periodically inspect and replace hoses if bulges, kinks, cuts, wear, or leaks are found.

SECURE THE DRAIN HOSE

- Remove the shipping material from the power cord. Drape the power cord over the console.
- Remove any cardboard used to move washer.

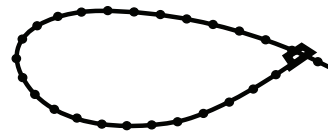

Beaded tie strap

- Wrap the drain hose to the laundry tub leg, drain standpipe or inlet hoses, with the beaded tie strap. Push fastener into the nearest hole in the beaded tie strap. See view A or B.

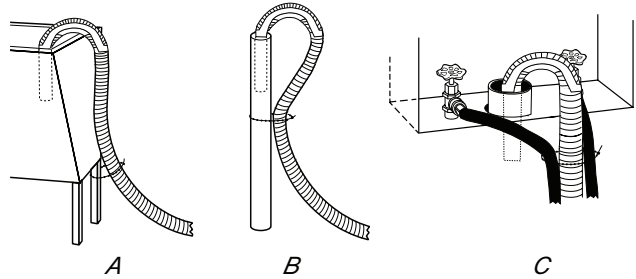

If the washer faucets and the drain standpipe are recessed, put the formed end of the drain hose into the standpipe. Tightly wrap the tie strap around the water inlet hoses and the drain hose. See view C.

LEVEL THE WASHER

Properly leveling your washer avoids excessive noise and vibration.

Install the front leveling feet

- Prop up the front of the washer about 4" (10.2 cm) with a wood block or similar object. The block needs to support the weight of the washer.

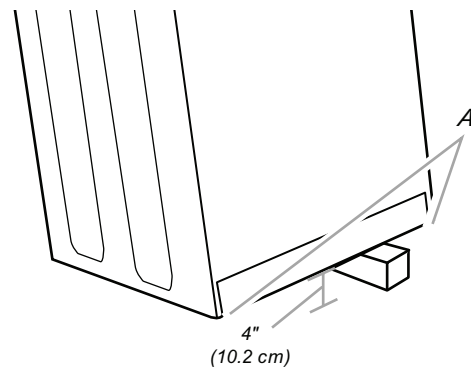

A. Threaded holes for feet

- Screw the locknut onto each foot to within 1" (2.5 cm) of the foot base.

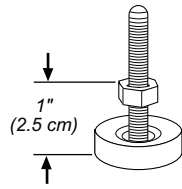

- Screw the feet into the threaded holes at the front corner of the washer until the nuts touch the washer. Twist the feet to install.

NOTE: Do not tighten the nuts until the washer is level.

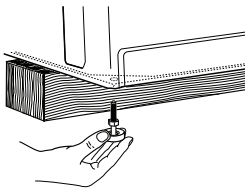

- Tilt the washer back and remove the wood block. Gently lower the washer to the floor.

Steps in final location

- Slide the washer to its final location.
- Tilt the washer forward until the rear of the washer is at least 4" (10.2 cm) off the floor. You may hear the self-adjusting rear feet click into place. Lower the washer to the floor.

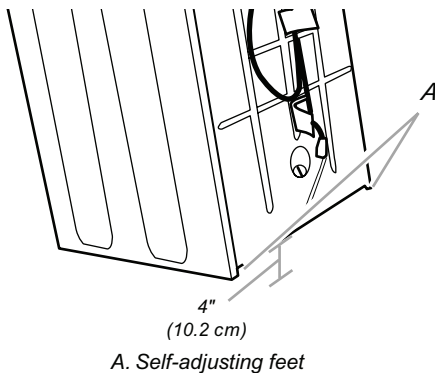

- Check the levelness of the washer by placing a level on the top edges of the washer, first side to side, then front to back.

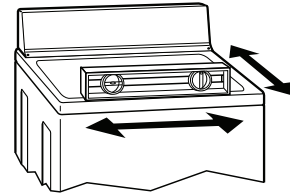

- If the washer is not level, move the washer out slightly, tip back, prop up the front of the washer with the wood block and adjust the feet up or down as necessary by twisting the feet. Turn the feet clockwise to raise the washer or counter-clockwise to lower the washer. Repeat steps 1 through 4 until washer is level.
- After the washer is in the final location and level, use a 9/16" or 14 mm open-end wrench to turn the nuts counter-clockwise on the feet tightly against the washer cabinet.

IMPORTANT: If the nuts are not tight against the washer cabinet, the washer may vibrate.

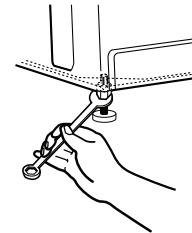

COMPLETE THE INSTALLATION

1. Check the electrical requirements. Be sure that you have the correct electrical supply and the recommended grounding method (see “Electrical Requirements”).
2. Check that all parts are now installed. If there is an extra part, go back through the steps to see which step was skipped.
3. Check that you have all of your tools.
4. Check that the yellow shipping materials were completely removed from the lower back of the washer.
5. Dispose of / recycle all packaging materials.
6. Check that the water faucets are on.
7. Check for leaks around faucets and inlet hoses.

WARNING



Electrical Shock Hazard

Plug into a grounded 3 prong outlet.

Do not remove ground prong.

Do not use an adapter.

Do not use an extension cord.

Failure to follow these instructions can result in death, fire, or electrical shock.

8. Plug into a grounded 3 prong outlet.
9. Remove the protective film on the console and any tape remaining on the washer.
10. Read “Washer Use.”
11. To test and to clean your washer, measure 1/2 of the normal recommended amount of powdered or liquid detergent and pour it into the washer basket or detergent dispenser (on some models). Close the lid. Select any cycle, and then pull the cycle control knob out to start the washer. Allow it to complete one whole cycle.

PRODUCT OPERATION

WASHER USE

STARTING YOUR WASHER

WARNING



Fire Hazard

Never place items in the washer that are dampened with gasoline or other flammable fluids.

No washer can completely remove oil.

Do not dry anything that has ever had any type of oil on it (including cooking oils).

Doing so can result in death, explosion, or fire.

WARNING



Electrical Shock Hazard

Plug into a grounded 3 prong outlet.

Do not remove ground prong.

Do not use an adapter.

Do not use an extension cord.

Failure to follow these instructions can result in death, fire, or electrical shock.

WARNING: To reduce the risk of fire, electric shock, or injury to persons, read the IMPORTANT SAFETY INSTRUCTIONS in the “Use and Care Guide” before operating this appliance.

1. Measure detergent and pour it into the washer. If desired, add powdered or liquid color-safe bleach.
2. Drop a sorted load of clothes loosely into your washer.
 - Load evenly to maintain washer balance. Mix large and small items. Items should move easily through the wash water.
 - Load only to the top of the basket as shown. Overloading can cause poor cleaning.

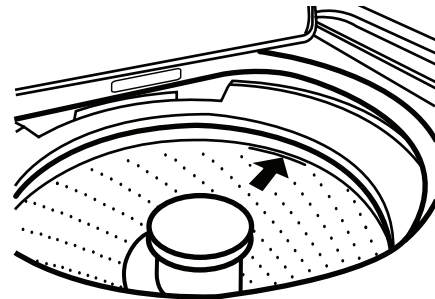

3. (OPTIONAL) Add liquid chlorine bleach.

NOTE: Follow the garment and the chlorine bleach manufacturers’ directions for proper use. Undiluted bleach will damage any fabric it touches. The damage appears as rips, holes, tears, or color loss and may not show up until several washings later. To avoid spilling, use a cup with a pouring spout. Do not let bleach splash, drip, or run down into the washer basket. Always measure liquid chlorine bleach. Do not guess. Do not use more than the manufacturer’s recommended amount for a full load. Use less with a smaller load size.

Styles 1 and 2: With liquid chlorine bleach dispenser (on some models)

- Use only liquid chlorine bleach in this dispenser. Do not use this dispenser to add powdered chlorine or color-safe bleach to your wash load. Pour measured liquid chlorine bleach into the liquid chlorine bleach dispenser. Bleach is immediately fed into washer and is diluted automatically during the wash part of the cycle.
- Dispensers on Timed Bleach models automatically dispense bleach at the proper time in the cycle for optimal performance, ensuring the cleanest and brightest loads.

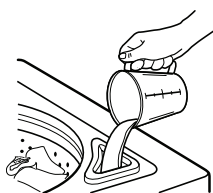

Style 1
Liquid chlorine
bleach dispenser
(on some models)

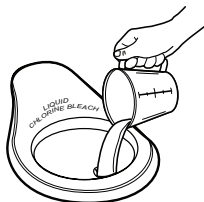

Style 2
Dispenser for
Timed Bleach models

Style 3: Without liquid chlorine bleach dispenser (on some models)

- Let the washer fill and begin agitating the load.
 - Add bleach 5 minutes into the wash cycle for best cleaning and so that bleach can be removed in the rinse cycle. Pour bleach around the agitator, not directly onto the load to avoid damaging clothing or other items in the load.
4. (OPTIONAL) Add liquid fabric softener.

NOTE: Do not spill or drip any fabric softener onto the clothes. Undiluted fabric softener can stain fabrics. Always dilute fabric softener with warm water. Using too much fabric softener can make some items (diapers and towels) nonabsorbent. If this happens, do not use it in every load, or use less of it in each load.

Style 1: With liquid fabric softener dispenser (on some models)

- Use only liquid fabric softener in this dispenser. Pour measured liquid fabric softener into the dispenser. Softener is added automatically during the rinse portion of the cycle. Dilute liquid fabric softener by filling the dispenser with warm water until liquid reaches the underside of the rim. See max fill line arrows.



Style 2: Without liquid fabric softener dispenser (on some models).

- In the final rinse only, add fabric softener that has been diluted with 1/2 to 1 cup (125 to 250 mL) warm water.
5. Close the washer lid. Washer will not agitate or spin with the lid open.
6. Turn the LOAD SIZE or WATER LEVEL selector to the correct setting for your wash load and the type of fabric being washed.
- You may change the load size or water level selection after the washer has started filling by turning the selector to a different setting.
 - On models with a variable Load Size or Water Level control, you should turn the knob to RESET, then to desired setting.
7. Select a Wash Temperature based on the type of fabric and soil being washed. Use the warmest wash water safe for the fabric. Follow garment label instructions.

The Automatic Temperature Control (ATC) (on some models) electronically senses and maintains a uniform water temperature by regulating incoming hot and cold water.

- Even in Cool wash, some warm water is let into the washer to maintain a minimum temperature of approximately 70°F (21°C).

Temperature Guide

Wash Temp	Suggested Fabrics
Hot	Whites and pastels Durable garments Heavy soils
Warm	Bright colors Moderate to light soils
Cool	Colors that bleed or fade Light soils
Cold	Colors that bleed or fade Light soils

NOTE: In wash water temperatures colder than 60°F (15.6°C), detergents do not dissolve well. Soils can be difficult to remove. Some fabrics can retain wear wrinkles and have increased pilling (the formation of small lint-like balls on the surface of garments).

8. You can customize your wash by adding rinse Options to your cycle selections. This knob has settings for:
 - Extra Rinse - Selecting this option provides a second rinse. An Extra Rinse can be added to any wash cycle.
 - Cycle Signal - A tone will sound at the end of the cycle. The sound level cannot be adjusted.

- Extra Rinse & Cycle Signal - This option combines both an Extra Rinse and a Cycle Signal at the end of the wash cycle.

9. The SensiCare™ System (on some models) is an integrated set of controls which work together to provide optimal wash temperatures, agitation times, and agitation/spin speeds based on the Fabric Select setting. The controls provide higher wash temperatures for more aggressive, heavy-duty cycles and slightly lower temperatures on cycles for delicate and hand wash items, to provide better fabric care. The timer knob allows you to decrease agitation time for light soils and increase agitation time for heavy soils.
10. Push in the Timer knob and turn it clockwise to the wash cycle you want. Reduce the wash time when using a small water level setting. Pull out the Timer knob to start the washer.



To stop or restart your washer:

- To stop the washer at any time, push in the Timer knob.
- To restart the washer, close the lid (if open) and pull out the Timer knob.

WASHER CARE

CLEANING YOUR WASHER

Use a soft, damp cloth or sponge to wipe up any spills such as detergent or bleach from the outside of your washer.

Clean your washer interior by mixing 1 cup (250 mL) of chlorine bleach and 2 cups (500 mL) of detergent. Pour this mixture into your washer and run it through a complete cycle using hot water. Repeat this process if necessary.

Remove any hard water deposits using only cleaners labeled as washer-safe.

Cleaning the liquid fabric softener dispenser (on some models):

1. Remove dispenser by grasping top with both hands and squeezing, while pushing upward with thumbs.
2. Rinse dispenser under warm water, then replace it.

NOTE: Some models are equipped with a liquid fabric softener dispenser. To avoid damage to the washer or clothing, do not wash clothes with the liquid fabric softener dispenser removed or add detergent or bleach to this dispenser; it is for liquid fabric softener only.

WATER INLET HOSES

Replace inlet hoses after 5 years of use to reduce the risk of hose failure. Periodically inspect and replace inlet hoses if bulges, kinks, cuts, wear or leaks are found.

When replacing your inlet hoses, mark the date of replacement on the label with a permanent marker.

MOVING AND STORAGE

Because some water may stay in the hoses, freezing can damage your washer. If storing or moving your washer during freezing weather, winterize it.

WINTERIZING YOUR WASHER

1. Shut off both water faucets. Disconnect and drain water inlet hoses. Pour 1 qt (1 L) of R.V.- type antifreeze into the basket.
2. Run washer on a drain and spin setting for about 30 seconds to mix the antifreeze and remaining water.
3. Unplug washer or disconnect power.

To use washer again

1. Flush water pipes and hoses. Reconnect water inlet hoses. Turn on both water faucets.

⚠ WARNING



Electrical Shock Hazard

Plug into a grounded 3 prong outlet.

Do not remove ground prong.

Do not use an adapter.

Do not use an extension cord.

Failure to follow these instructions can result in death, fire, or electrical shock.

2. Plug in washer or reconnect power.
3. Run the washer through a complete cycle with 1 cup (250 mL) of detergent to clean out antifreeze.

STORAGE, NONUSE OR VACATION CARE

Operate your washer only when you are at home. If you will be on vacation or not using your washer for an extended period of time, you should:

1. Unplug washer or disconnect power.
2. Turn off the water supply to the washer. This helps avoid accidental flooding (due to a water pressure surge) while you are away.

TROUBLESHOOTING

WASHER AND COMPONENTS

NOISY

- **Is the load balanced and the washer level?**
The wash load should be balanced and not overloaded. The washer must be level. The front feet should be properly installed and the nuts tightened. Reset the rear leveling legs (if needed). See “Starting Your Washer,” page 3-1.
- **Did you completely remove the yellow shipping strap with cotter pins?** See “Remove Shipping Materials,” page 2-5.
- **Are the gears engaging after the drain and before spin, or is the upper part of agitator clicking during wash?** These are normal washer noises.

LEAKING

- **Check the following:**
Are the fill hoses tight?
Are the fill hose washers properly seated?
- **Is the sink or drain clogged?** Sink and standpipe must be able to handle 17 gal. (64 L) of water per minute.
- **Is water deflecting off the tub ring or the load?** Center the tub before starting the washer. The wash load should be balanced and not overloaded. The fill or spray rinses can deflect off the load. The washer must be level. The front feet should be properly installed and the nuts tightened. Reset the rear leveling legs (if needed). See “Level the Washer,” page 2-8.
- **Check household plumbing for leaks.**

BASKET CROOKED

- **Was the washer basket pulled forward during loading?** Push the basket to the center before starting wash.
- **Is the load balanced and the washer level?**
The wash load should be balanced and not overloaded. The washer must be level. The front feet should be properly installed and the nuts tightened. Reset the rear leveling legs (if needed). See “Level the Washer,” page 2-8.
- **The washer basket moves while washing.**
This is normal.

AGITATOR OPERATION

- **The top of the agitator is loose or moves in only one direction.** This is normal.

DISPENSERS CLOGGED OR BLEACH LEAKING

- **Did you follow the manufacturer’s directions when adding detergent and fabric softener to the dispensers (on some models)?** Measure detergent and fabric softener. Slowly pour into the dispensers. Wipe up all spills. Dilute fabric softener in the fabric softener dispenser.
- **Did you put powdered or color-safe bleach into the liquid chlorine bleach dispenser (on some models)?** Add powdered or liquid color-safe bleach directly to the basket. Do not use the chlorine bleach dispenser for color-safe bleach.

WASHER OPERATION

WASHER WON'T RUN, FILL, RINSE OR AGITATE; WASHER STOPS

WARNING



Electrical Shock Hazard

Plug into a grounded 3 prong outlet.
Do not remove ground prong.
Do not use an adapter.
Do not use an extension cord.
Failure to follow these instructions can result in death, fire, or electrical shock.

- **Is the power cord plugged into a grounded 3 prong outlet?** Plug power cord into a grounded 3 prong outlet.
- **Are you using an extension cord?** Do not use an extension cord.
- **Is the indicator on the Timer knob properly lined up with a cycle?** Turn the Timer knob to the right slightly and pull to start.
- **Are the water inlet valve screens clogged?** Turn off the water and remove inlet hoses from the washer. Remove any accumulated film or particles. Reinstall hoses, turn on water and check for leaks.
- **Are both the hot and cold water faucets turned on?** Turn on the water.
- **Is the water inlet hose kinked?** Straighten the hoses.
- **Does the water level seem too low, or does the washer appear to not fill completely?** The top of the agitator is much higher than the highest water level. This is normal and necessary for clothes to move freely.
- **Has a household fuse blown, or has a circuit breaker tripped?** Replace the fuse or reset the circuit breaker. If the problem continues, call an electrician.

- **Is the washer in a normal pause in the cycle?** The washer pauses for about 2 minutes during certain cycles. Allow the cycle to continue. Some cycles feature periods of agitation and soak.
- **Is the washer overloaded?** Wash smaller loads.
- **Is the lid open?** The lid must be closed during operation. Washer will not agitate or spin with the lid open.

WASHER WON'T DRAIN OR SPIN

- **Is the drain hose clogged, or the end of the drain hose more than 96" (244 cm) above the floor?** See "Connect Drain Hose," page 2-6 for proper installation of drain hose.
- **Is the lid open?** The lid must be closed during operation. Washer will not agitate or spin with the lid open.
- **Is there excessive sudsing?** Always measure detergent. Follow manufacturer's directions. If you have very soft water, you might need to use less detergent.

WASHER CONTINUES TO FILL OR DRAIN; CYCLE SEEMS STUCK

- **Is the top of the drain hose lower than the water level in washer?** The top of the hose must be higher than the water level in the washer for proper operation. See "Drain System," page 2-3.
- **Does the drain hose fit too tightly in the standpipe, or is it taped to the standpipe?** The drain hose should be loose yet fit securely. Do not seal the drain hose with tape. The hose needs an air gap. See "Secure the Drain Hose," page 2-8.

WASH/RINSE TEMPERATURE NOT WHAT I SELECTED

- **Are the hot and cold water inlet hoses reversed?** See "Connect the Inlet Hoses," page 2-7 for more information. As your frequency of loads washed increases, the water temperature may decrease for hot and warm temperatures. This is normal.

WASHER RESULTS

LOAD TOO WET

- **Did you use the right cycle for the load being washed?** Select a cycle with a higher spin speed (if available).
- **Did you use a cold rinse?** Cold rinses leave loads wetter than warm rinses. This is normal.

RESIDUE OR LINT ON LOAD

- **Did you sort properly?** Sort lint gives (towels, chenille) from lint takers (corduroy, synthetics). Also sort by color.
- **Did you overload the washer?** The wash load must be balanced and not overloaded. Clothes should move freely. Lint can be trapped in the load if overloaded. Wash smaller loads.
- **Did you select the correct water level?** The water level should be correct for the load size. Clothes should move freely in the water.
- **Did you use enough detergent?** Follow manufacturer's directions. Use enough detergent to hold the lint in the water.
- **Did you line dry your clothing?** If so, you can expect some lint on the clothing.
- **Check the following:**
 - Was paper or tissue left in the pockets?
 - Is your water colder than 60°F (15.6°C)? Wash water colder than 60°F (15.6°C) may not completely dissolve the detergent.
 - Did you use the proper cycle time for the load? Reducing wash time (duration) is another way to reduce lint.

STAINS ON LOAD

- **Did you follow the manufacturer's directions when adding detergent and fabric softener?** Measure detergent and fabric softener. Use enough detergent to remove soil and hold it in suspension. Dilute fabric softener and add to the rinse portion of a cycle only. Do not drip fabric softener on clothes.

- **Is there above average iron (rust) in water?** You may need to install an iron filter.
- **Did you properly sort the load?** Sort dark clothes from whites and lights.
- **Did you unload the washer promptly?** To avoid dye transfer, unload the washer as soon as it stops.

LOAD IS WRINKLED

- **Did you unload the washer promptly?** Unload the washer as soon as it stops.
- **Did you use the right cycle for the load being washed?** Use the cycle for Casual or Permanent Press clothes or another cycle with low spin speeds (if available) to reduce wrinkling.
- **Did you overload the washer?** The wash load must be balanced and not overloaded. Loads should move freely during washing. To reduce wrinkling of permanent press clothes and some synthetic knits, use a large load size to provide more space.
- **Are the hot and cold water hoses reversed?** Check that the hot and cold water hoses are connected to the right faucets. See "Connect the Inlet Hoses," page 2-7.

LOAD IS TANGLED OR TWISTED

- **Did you overload the washer?** The wash load must be balanced and not overloaded. Loads should move freely during washing.
- **Did you wrap items around the agitator?** Drop items loosely into the washer. Do not wrap items around the agitator.

GRAY WHITES, DINGY COLORS

- **Did you properly sort the load?** Dye transfer can occur when mixing whites and colors in a load. Sort dark clothes from whites and lights.
- **Was the wash temperature too low?** Use hot or warm washes if safe for the load. Make sure your hot water system is adequate to provide a hot water wash.

- **Did you use enough detergent, or do you have hard water?** Use more detergent for washing heavy soils in cold or hard water.
- **Are the hot and cold water hoses reversed?** Check that the hot and cold water hoses are connected to the right faucets. See “Connect the Inlet Hoses,” page 2-7.

GARMENTS DAMAGED

- **Check the following:**

Were sharp items removed from pockets before washing? Empty pockets, zip zippers, snap or hook fasteners before washing.

Were strings and sashes tied to avoid tangling?

Were items damaged before washing? Mend rips and broken threads in seams before washing.

- **Did you overload the washer?** The wash load must be balanced and not overloaded. Loads should move freely during washing.
- **Did you add chlorine bleach properly?** Do not pour chlorine bleach directly onto load. Wipe up bleach spills. Undiluted bleach will damage fabrics. Do not place load items on top of the bleach dispenser when loading and unloading the washer (on some models).
- **Did you follow the manufacturer’s care label instructions?**

COMPONENT ACCESS

This section instructs you on how to service each component inside the Maytag Centennial™ Top-Load Washer. The components and their locations are shown below.

COMPONENT LOCATIONS

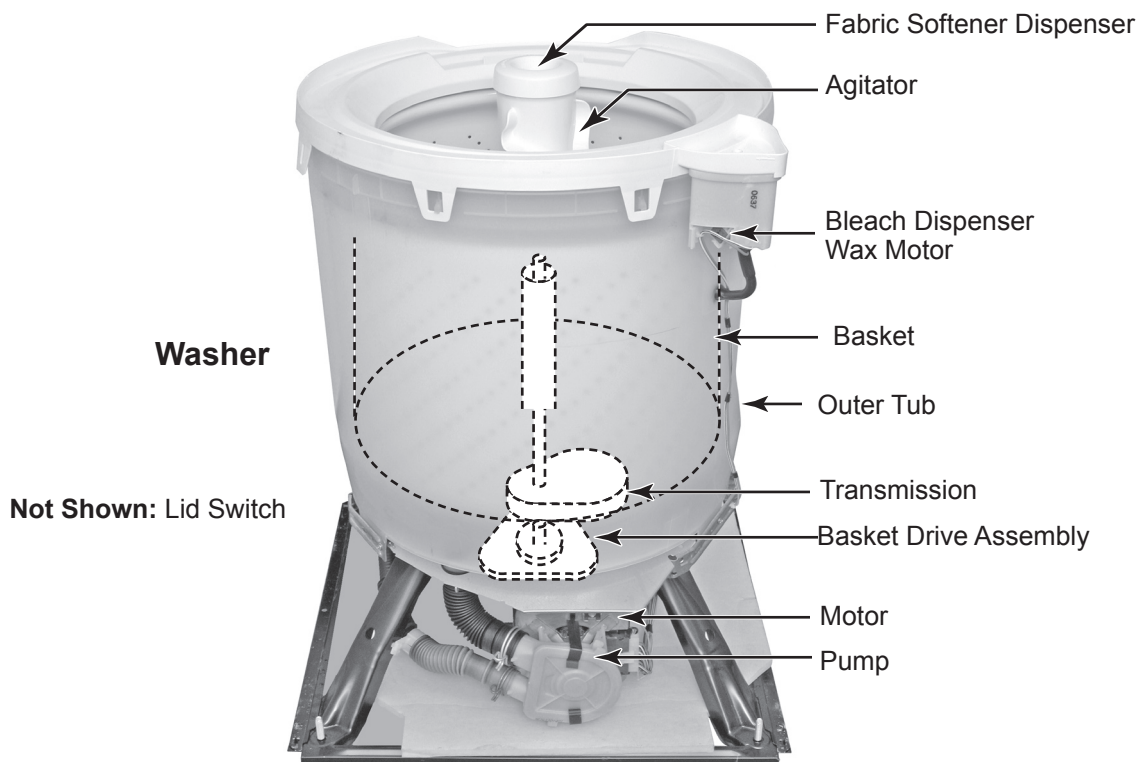
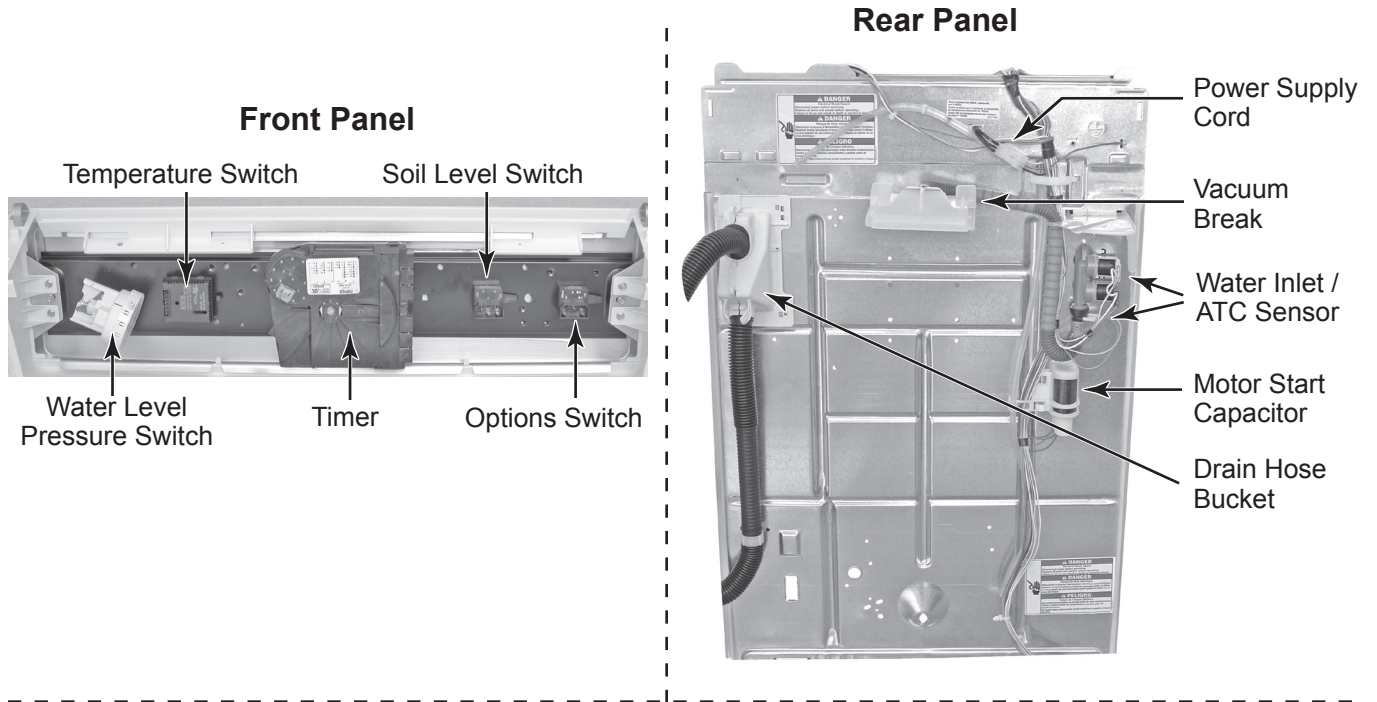

REMOVING THE CONSOLE COMPONENTS AND THE POWER SUPPLY CORD

⚠ WARNING



Electrical Shock Hazard

Disconnect power before servicing.

Replace all parts and panels before operating.

Failure to do so can result in death or electrical shock.

The console consists of the following serviceable components:

- Water Level Pressure Switch (A)
- Temperature Switch (B)
- Timer (C)
- Soil Level Switch (D)
- Options Switch (E)

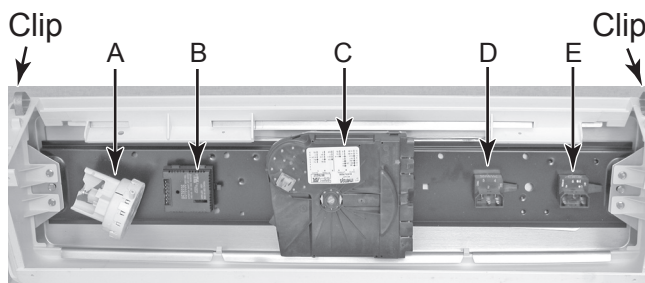

1. Unplug washer or disconnect power.
2. Slide a putty knife under the right or left corner of the control panel. Lift the corner of the panel and push back on the knife blade to release the clip. Repeat the procedure for the other clip.
3. Rotate the control panel so that the components face the front (see above).



4. To remove the timer:

- a) Remove the control knob as follows: Push the knob in. Hold the rear of the shaft by the slotted end with a small screwdriver so it does not move, then pull the knob off the front of the shaft.
- b) Pull the cover and plate off the timer shaft.
- c) Pull the three wire connectors off the timer terminals.

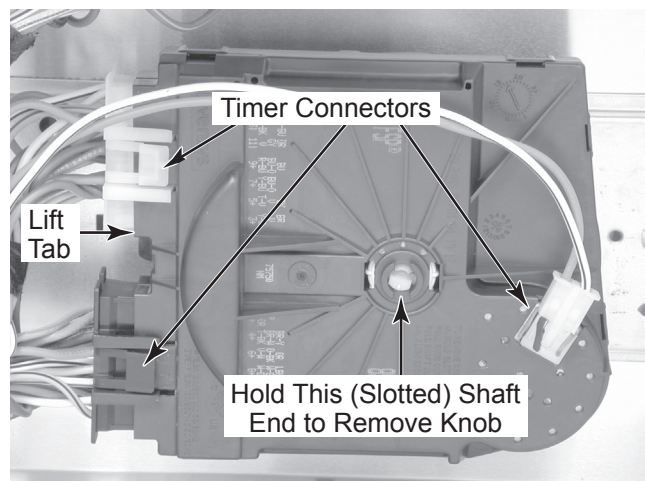

- d) Remove the 3/16" hex-head screw from the front of the timer.
- e) Lift the timer locking tab (see the photo above) so that it clears the hole in the console. Slide the timer to the left until the catches clear the console slots, and remove the timer from the console.



5. **To remove the temperature switch:**
 - a) Pull the knob off the switch shaft.
 - b) Disconnect the wire connector from the switch terminals.
 - c) Lift the locking tab so that it clears the hole in the console, rotate the switch approximately 30° clockwise so that the square on the front aligns with the cutout, and remove the switch from the console.

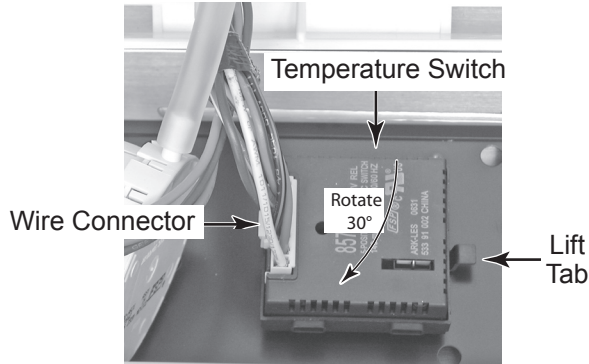

6. **To remove the soil level or options switch:**
 - a) Pull the knob off the switch shaft.
 - b) Unlatch and disconnect the wire connector from the switch terminals.
 - c) Lift the locking tab so that it clears the hole in the console, rotate the switch approximately 30° clockwise so that the square on the front aligns with the cutout, and remove the switch from the console.

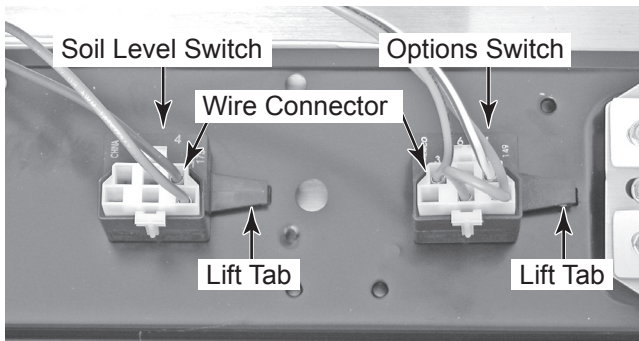

7. **To remove the water level pressure switch:**
 - a) Pull the pressure hose off the switch.
 - b) Disconnect the wire connector from the switch terminals.
 - c) Lift the locking tab, rotate the switch approximately 30° clockwise so that the square on the front aligns with the cutout, and remove the switch from the console.

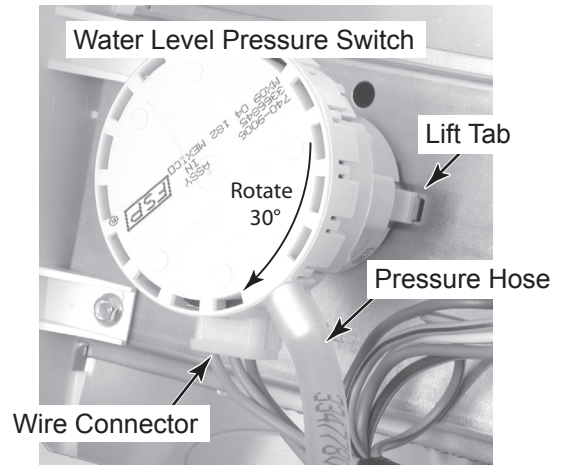

8. **To remove the power supply cord:**
 - a) Lift up on the locking tab and disconnect the power supply cord connector from the main harness.
 - b) Press the locking tab, and pull the strain relief and power supply cord out of the rear panel cutout.

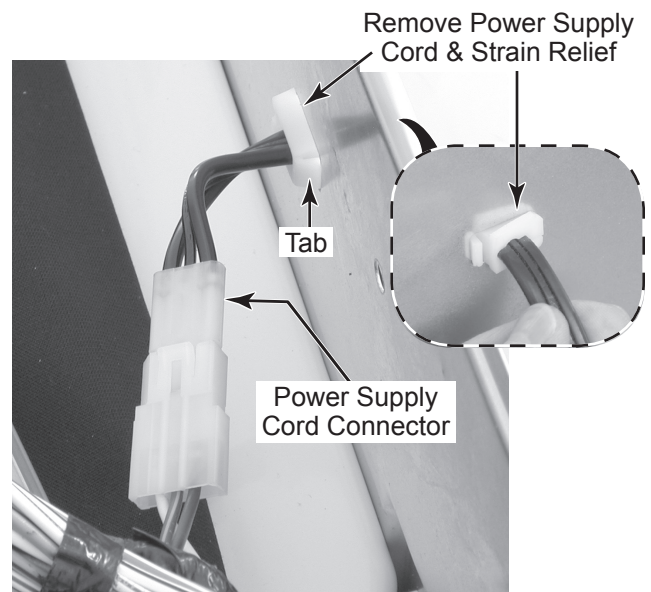

REMOVING THE LID SWITCH

⚠ WARNING



Electrical Shock Hazard
Disconnect power before servicing.
Replace all parts and panels before operating.
Failure to do so can result in death or electrical shock.

1. Unplug washer or disconnect power.
2. Remove the control panel and position it back out of the way (see page 4-2 for the procedure).

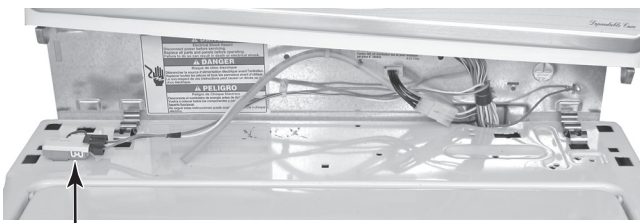

Lid Switch Connector

3. Lift the locking tab, and disconnect the main harness from the lid switch connector (see the top right photo).
4. Remove the 5/16" hex-head screw from the green ground wire on the lid switch.

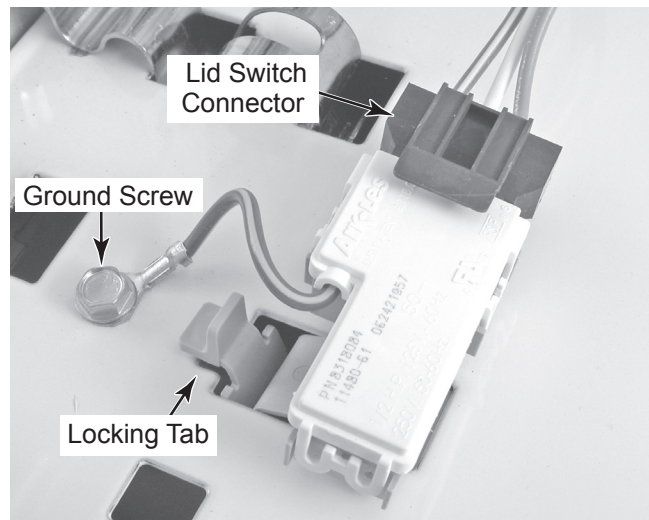

5. Lift the washer lid so it is straight up.
6. Release the locking tab and pull the lid switch up and out of the cabinet top opening.

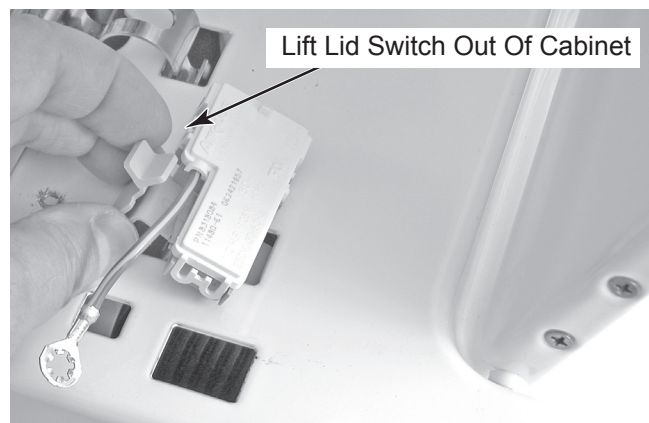

REMOVING THE BLEACH DISPENSER WAX MOTOR

⚠ WARNING



Electrical Shock Hazard
Disconnect power before servicing.
Replace all parts and panels before operating.
Failure to do so can result in death or electrical shock.

1. Unplug washer or disconnect power.
2. Remove the control panel and position it back out of the way (see page 4-2 for the procedure).
3. Disconnect the main harness connector from the lid switch connector.
4. Use a screwdriver and unclip the left and right cabinet spring clips from the cabinet top.

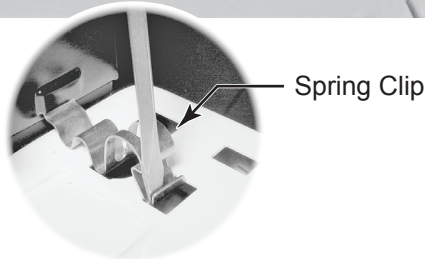
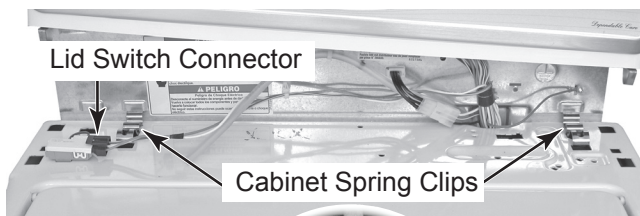

5. Rotate the cabinet forward so you can access the top of the tub (see the top right photo).



6. Disconnect the hose from the dispenser.
7. Disconnect the 2-wire connector from the bleach dispenser wax motor terminals.

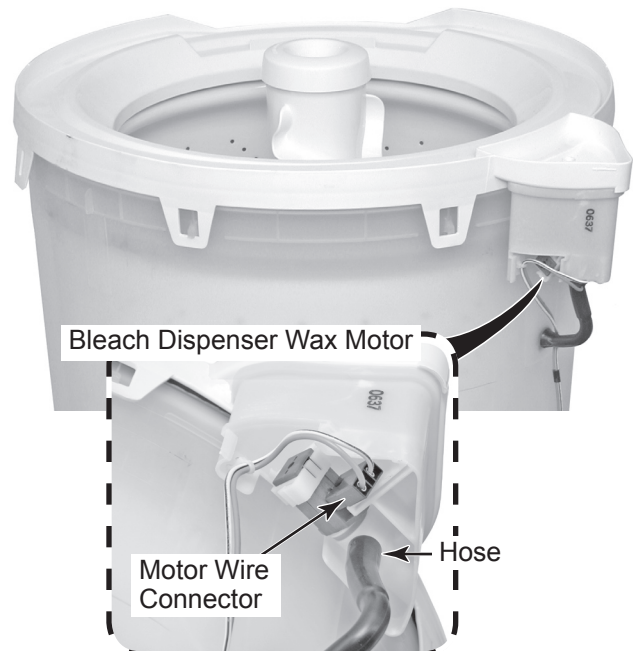

Continued on the next page.

8. Unsnap the tub ring tabs from the outer tub and remove tub ring.

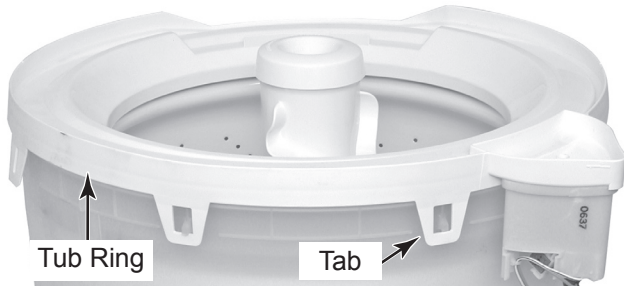

9. Turn the tub ring over so you can access the bleach dispenser wax motor.
10. Using a small screwdriver, pry up on the locking tab, slide the retaining ring off the bleach dispenser wax motor, and remove bleach dispenser wax motor.
11. Turn the bleach dispenser wax motor to unlock the tabs, and pull the motor and seal out of the holder in the tub ring.

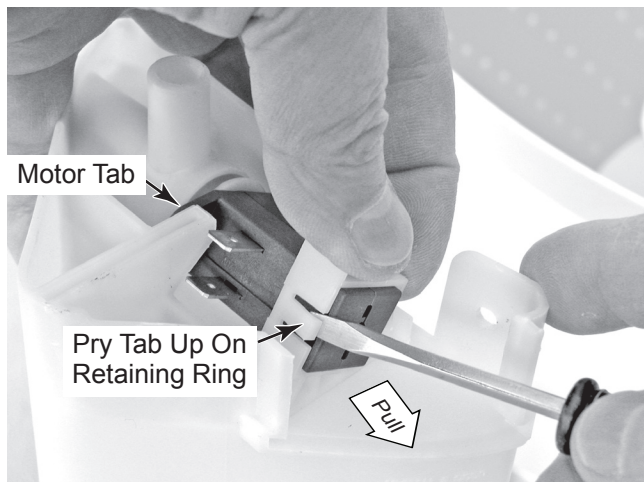

12. Pull the seal off the shaft of the bleach dispenser wax motor.

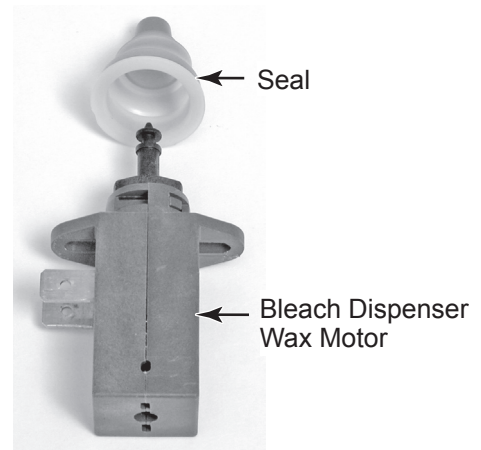

REASSEMBLY NOTE: When you install the tub ring on the tub, position the ring with the keyed (narrow) locking tab slot, as shown below.

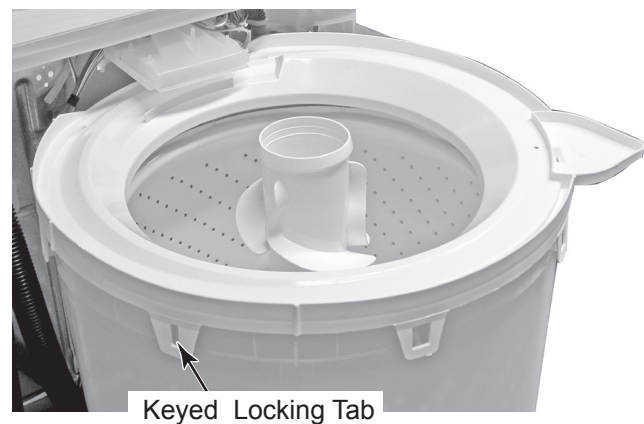

REMOVING THE REAR PANEL COMPONENTS

⚠ WARNING



Electrical Shock Hazard

Disconnect power before servicing.

Replace all parts and panels before operating.

Failure to do so can result in death or electrical shock.

1. Unplug washer or disconnect power.
2. Remove the control panel and position it back out of the way (see page 4-2 for the procedure).
3. Rotate the cabinet forward so you can access the rear panel components.

The following rear panel components are serviced in this section:

- Vacuum Break
- Water Inlet/ATC Sensor
- Motor Start Capacitor
- Drain Hose Bucket

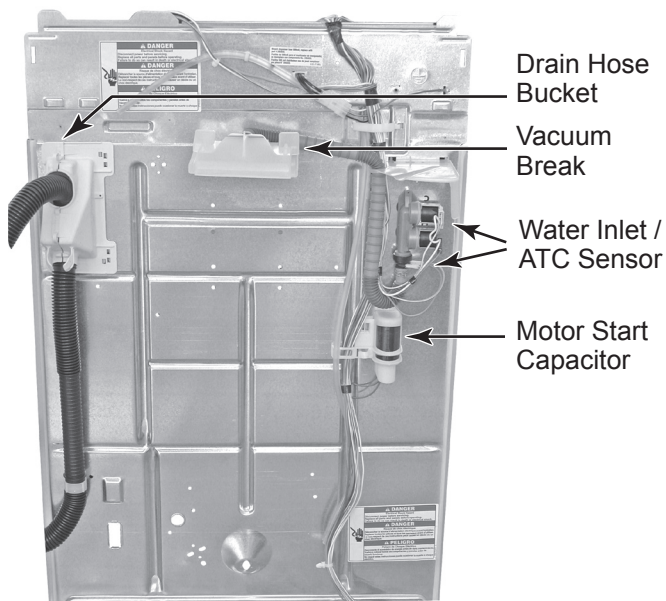

4. To remove the vacuum break:
 - a) Loosen the clamp and disconnect the hose from the vacuum break.

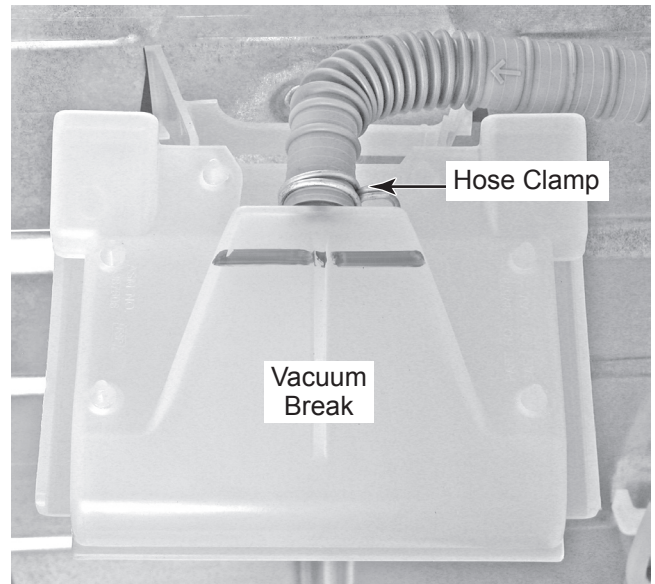

- b) Press out at the bottom of both of the supports, and pull the vacuum break from the rear panel slots.

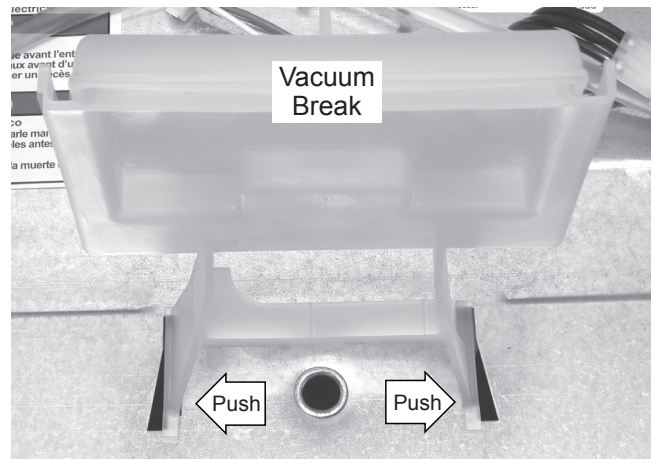

Continued on the next page.

5. **To remove the water inlet/ATC sensor:**
 - a) Remove the hex-head mounting screw from the rear panel.
 - b) Lift and remove the water inlet/ATC sensor from the rear panel.

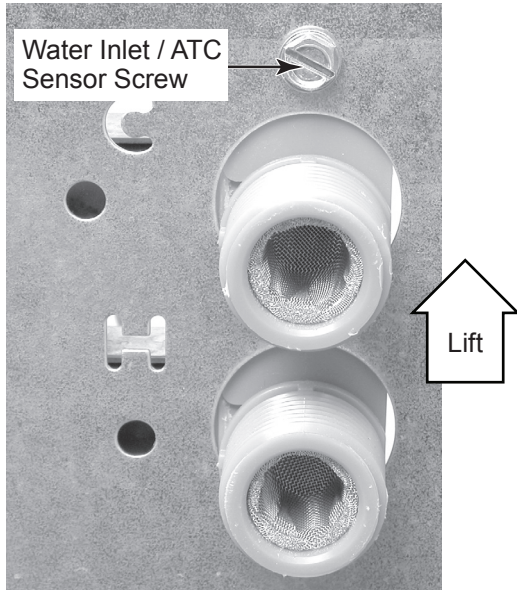

- c) Loosen the clamp and disconnect the hose from the water inlet.
- d) Disconnect the cold (white) and hot (red) wire connectors from the water inlet solenoid terminals.
- e) Disconnect the pink and orange-white wires from the ATC sensor terminals.

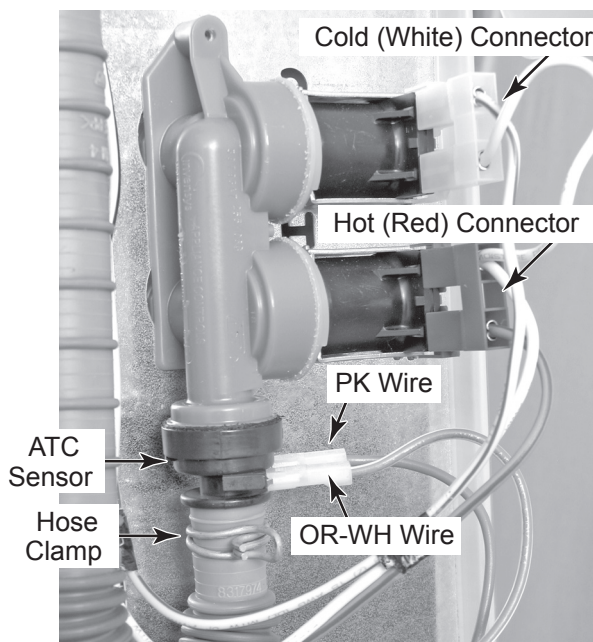

6. **To remove the motor start capacitor:**
 - a) On the outside of the rear panel, squeeze the locking tabs on the capacitor holder pin, and push the pin out of its hole. Unhook the holder, and remove it from the panel.

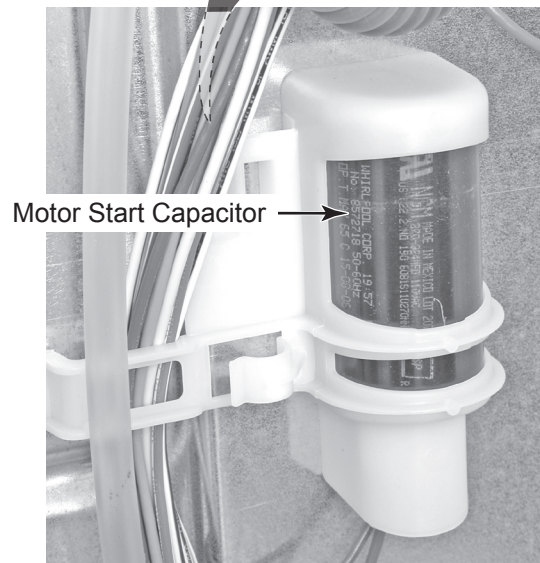
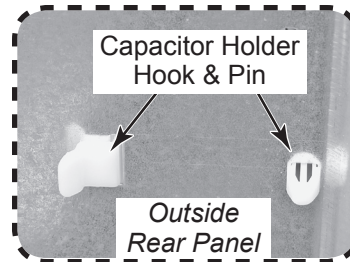

- b) Discharge the capacitor by touching the leads of a 20,000 Ω resistor to the two terminals.
- c) Disconnect the two wire connectors from the capacitor terminals.
- d) Remove the capacitor from the holder.

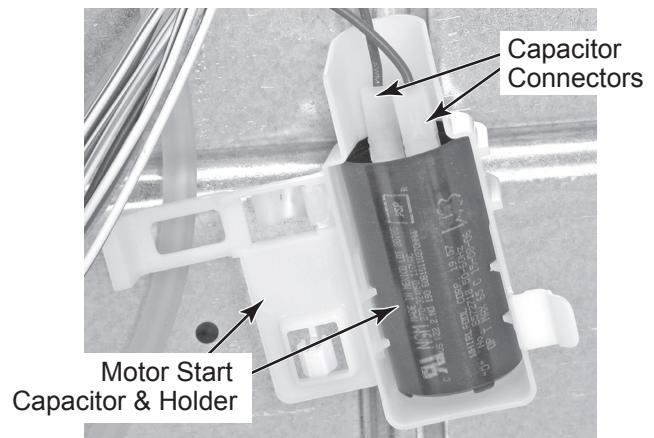

7. **To remove the drain hose bucket:**

a) On the outside of the rear panel, squeeze the locking tabs on the drain hose bucket, and push the tabs out of their slots.

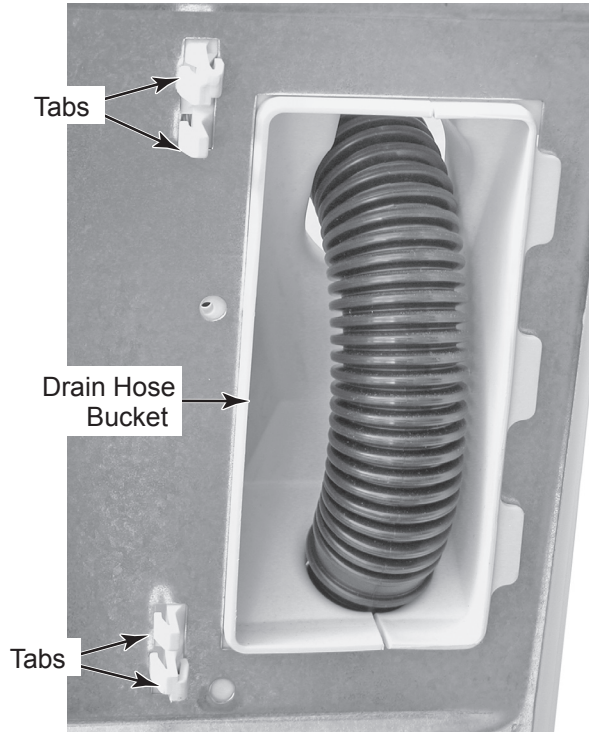

b) Lift the two locking arms on the bucket to release the tabs.

c) Open the bucket sections and remove the drain hose.

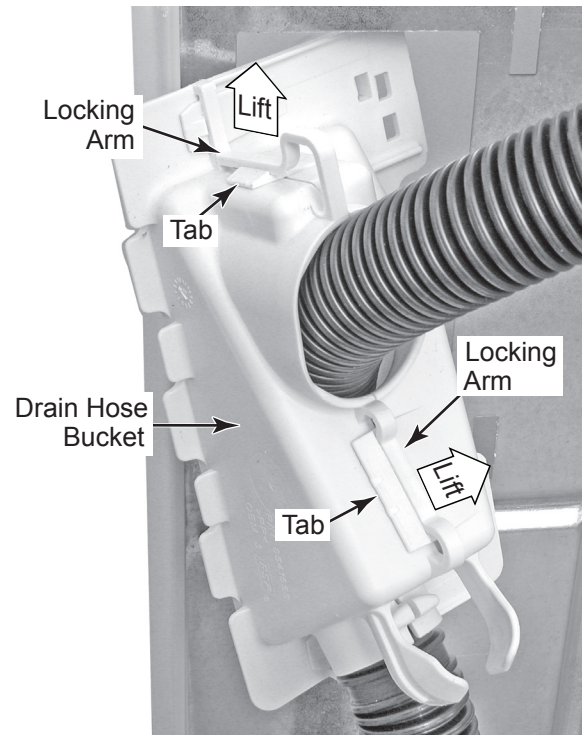

REMOVING THE PUMP AND MOTOR

⚠ WARNING



Electrical Shock Hazard
Disconnect power before servicing.
Replace all parts and panels before operating.
Failure to do so can result in death or electrical shock.

1. Unplug washer or disconnect power.
2. Tilt the cabinet forward and remove cabinet (see page 4-5 for the procedure).
3. **To remove the pump:**
 - a) Place a container near the two pump hoses to catch the water.

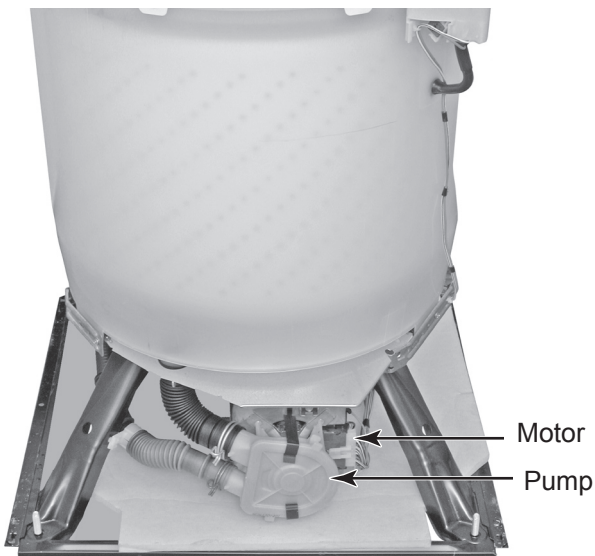

- b) Loosen the two clamps from the tub outlet and drain hoses and pull the hoses off the pump.
- c) Release the two spring clips and pull the pump away from the motor.

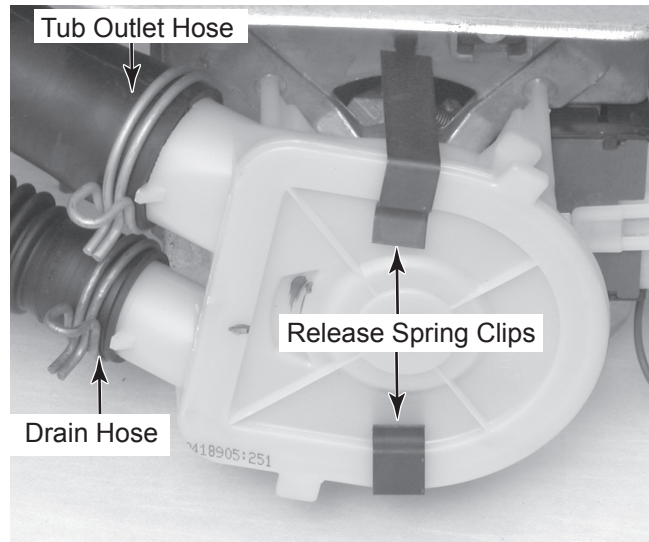

REASSEMBLY NOTE: Position the pump on the motor shaft with the feet in the bracket indentations (circled below).

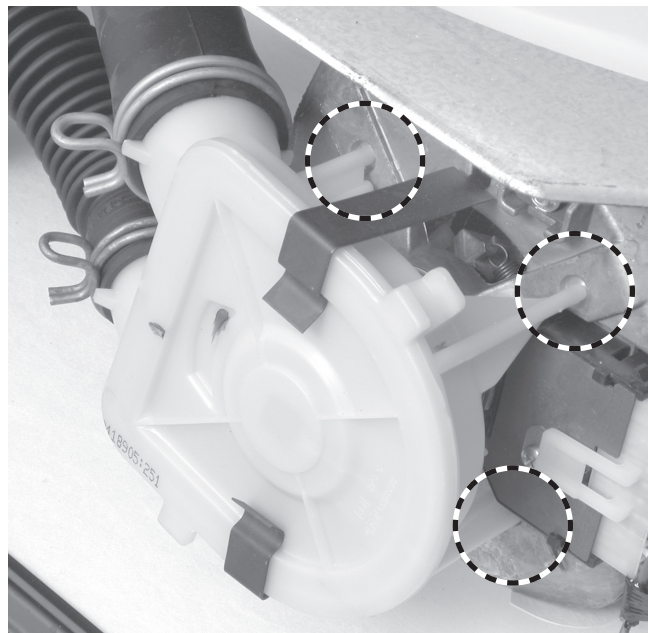

4. **To remove the motor:**

- a) Remove the pump from the motor (see step 3).
- b) Disconnect the two wires from the motor start capacitor terminals (see page 4-8).
- c) Raise the locking arm and disconnect the wire connector from the motor.
- d) Remove the hex-head screw from each of the two motor mounting spring clips.
- e) Support the bottom of the motor with one hand to keep it from falling, and pry the ends of the two spring clips off the motor with a screwdriver (see the round inset below).

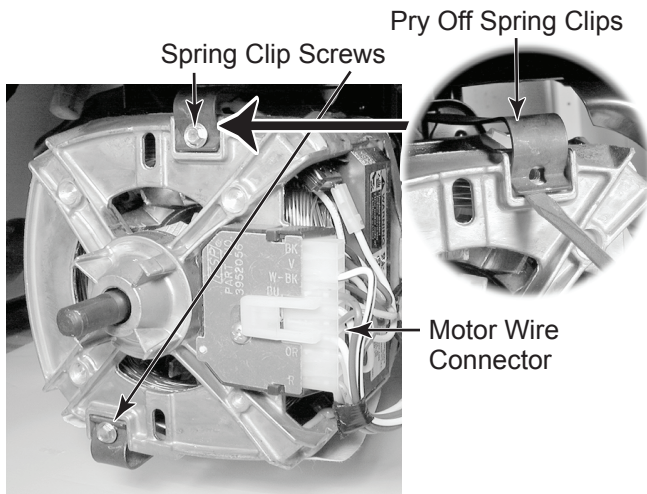

- f) Pull the motor away from the washer until the motor coupler pins disengage from the motor coupler isolator, and remove the motor.

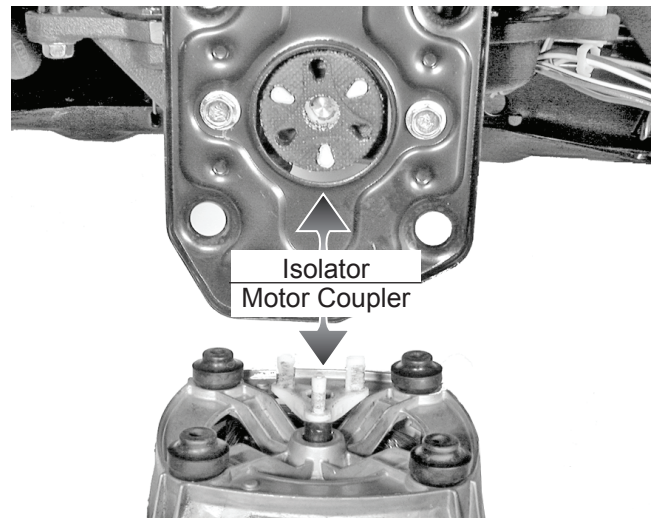

- g) Remove the following components from the motor:

- Motor Coupler
- Rubber Motor Mounts (4)
- Cardboard Shield

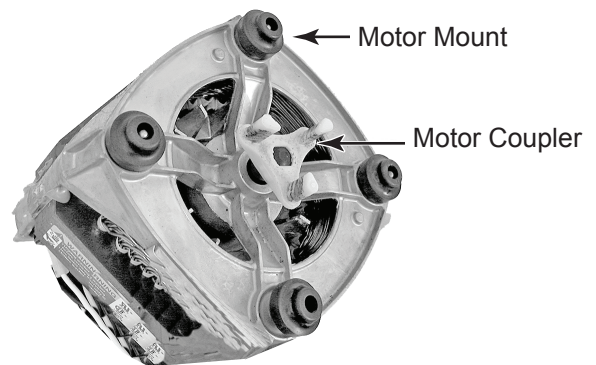

REMOVING THE AGITATOR AND TRANSMISSION

⚠ WARNING



Electrical Shock Hazard

Disconnect power before servicing.

Replace all parts and panels before operating.

Failure to do so can result in death or electrical shock.

1. Unplug washer or disconnect power.
2. **To remove the agitator:**
 - a) Lift the washer lid.
 - b) Pull the fabric softener dispenser off the top of the agitator.

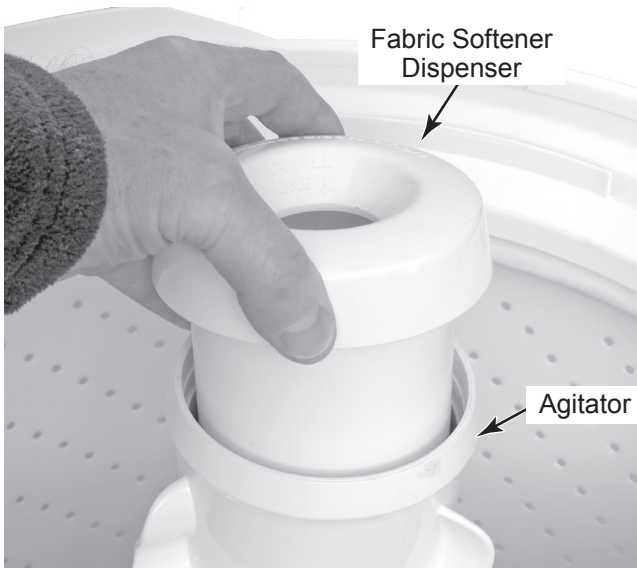

- c) Pull the barrier cap and rubber O-ring out of the agitator.

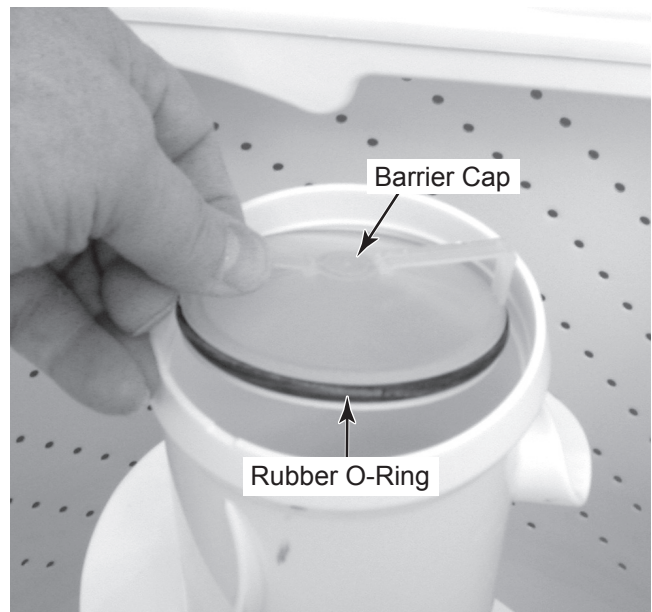

- d) Remove the 7/16" hex-head bolt from the agitator and lift the agitator out of the washer tub.

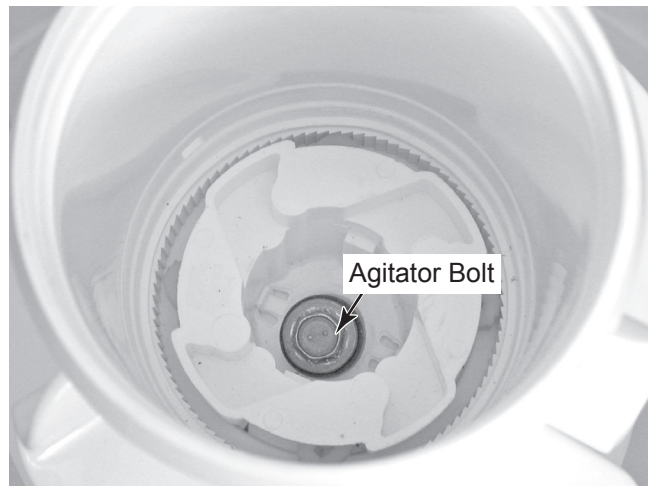

3. **To remove the transmission:**

- a) Remove the agitator (see step 2).
- b) Slide the agitator clip and washer up and off the transmission shaft.

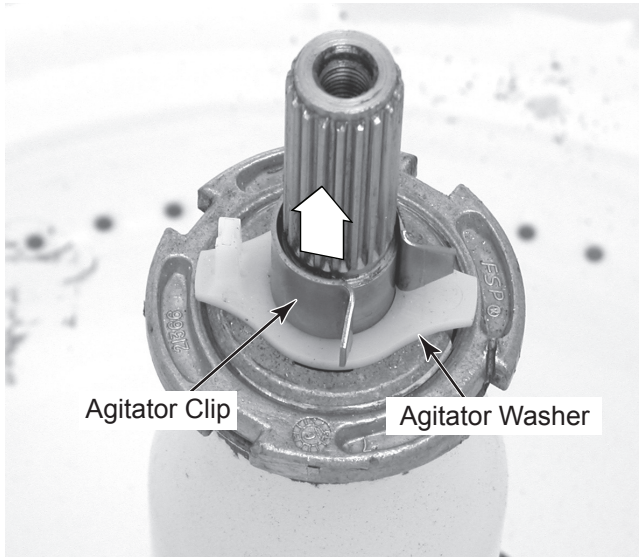

- c) Remove the pump and motor (see page 4-10 for the procedure).

- d) Squeeze the locking tabs together and push the wire standoff out of the transmission mounting hole.
- e) Remove the three 1/2" bolts from the transmission.

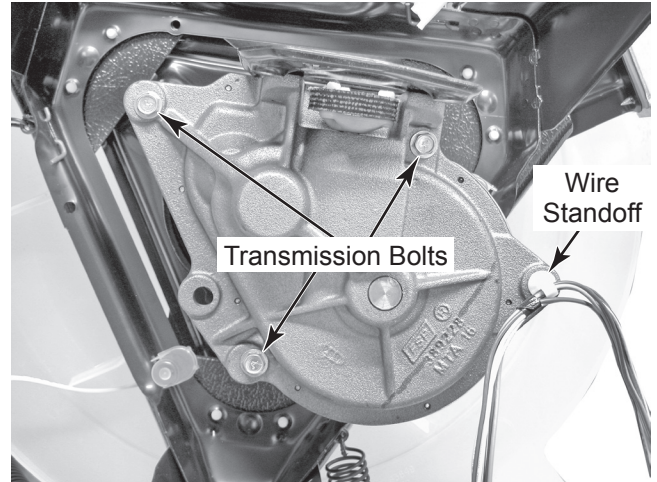

- f) Pull the transmission away from the washer and remove transmission.
- g) Remove the isolator from the motor coupler.

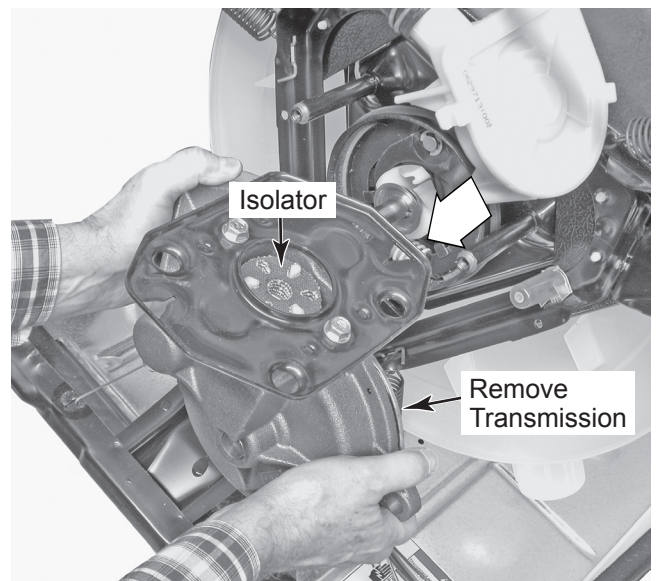

Continued on the next page.

- h) Remove the thrust washer from the agitator shaft.
- i) Use a screwdriver, and unsnap the spring retaining clip and the clutch retaining ring from the agitator shaft.
- j) Slide the clutch off the agitator shaft.
- k) Slide the retaining clip off the agitator shaft.

- l) Use a pair of pliers and remove the pad assembly from the clutch drum.
- m) Inspect the inside contact surface of the drum for scratch marks, or uneven wear. Inspect the clutch pad assembly for loose, or worn pads (see the inset photo below). If the distance between the clutch pad contact surface and the clutch pad rivet head is less than .10", replace the clutch lining.

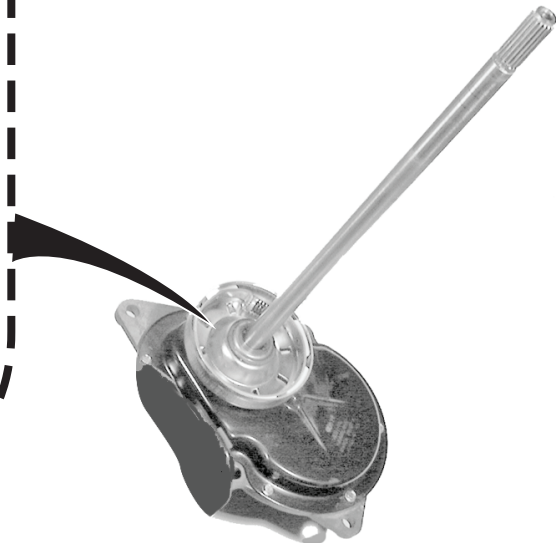
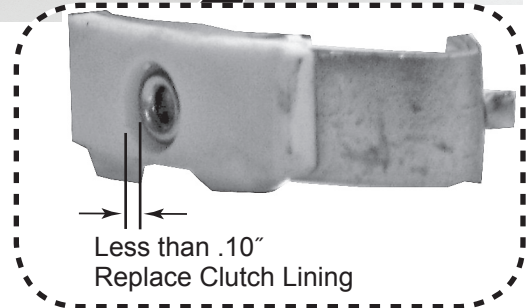
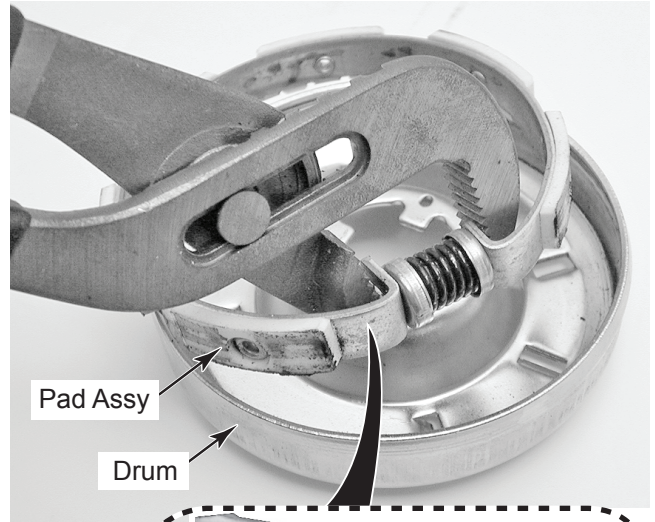
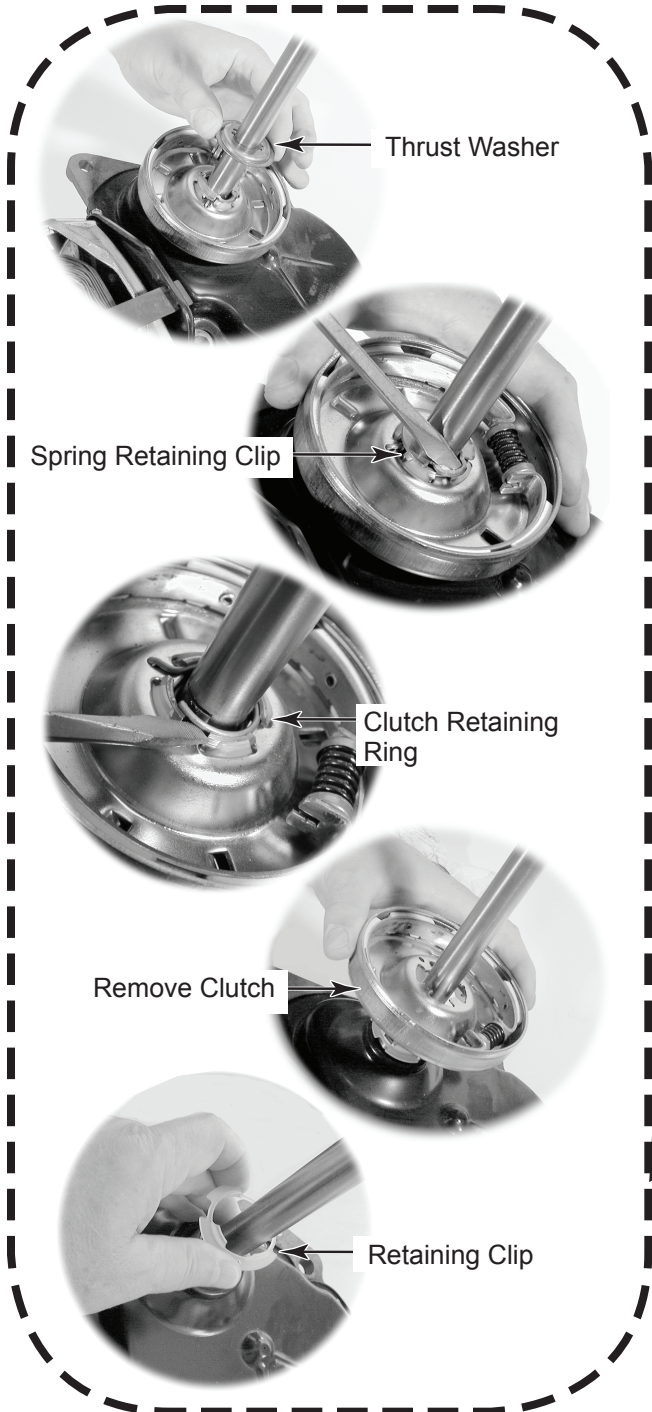

- n) Remove the motor from the transmission (see page 4-11 for the procedure).
- o) Remove the two 1/2" hex-head bolts from the motor plate and remove the plate.

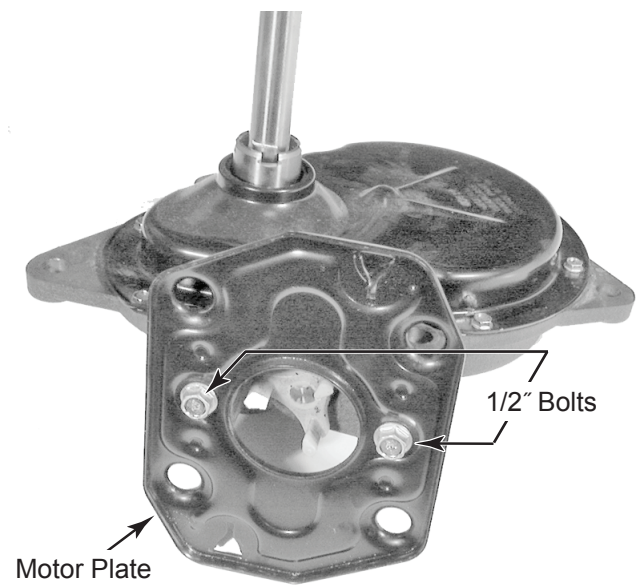

REMOVING THE BASKET, OUTER TUB, AND BASKET DRIVE ASSEMBLY

⚠ WARNING



Electrical Shock Hazard

Disconnect power before servicing.
Replace all parts and panels before operating.

Failure to do so can result in death or electrical shock.

1. Unplug washer or disconnect power.
2. Tilt the cabinet forward and remove cabinet (see page 4-5 for the procedure).
3. Remove the end of the dispenser hose from the dispenser.
4. Unsnap the tub ring tabs from the outer tub and remove the tub ring.
5. Remove the agitator from the tub (see

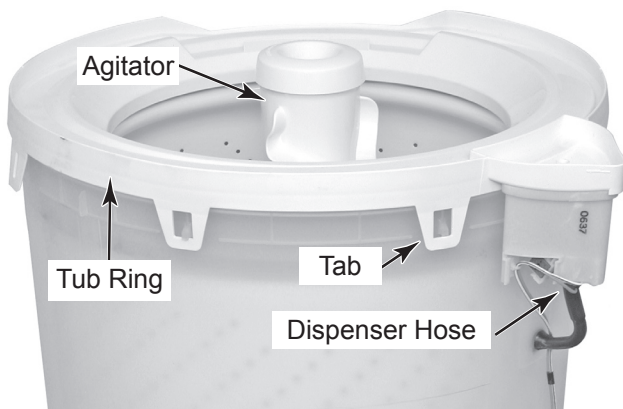

6. Slide the agitator clip and washer up and off the transmission shaft.

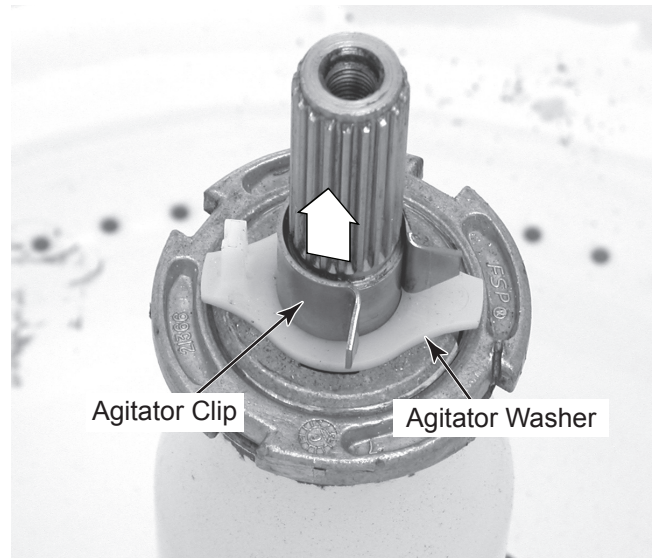

7. **To remove the basket:**

- a) Use a Spanner wrench and remove the Spanner nut from the drive block. Tap the Spanner wrench with a hammer to loosen the nut counterclockwise while holding the basket.

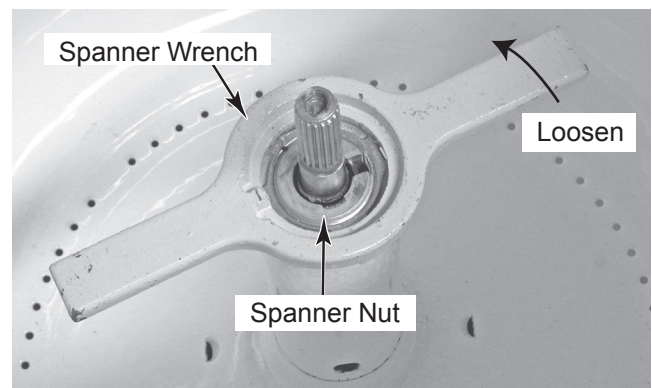

- b) Lift the basket off the drive block, and remove the basket from the outer tub.

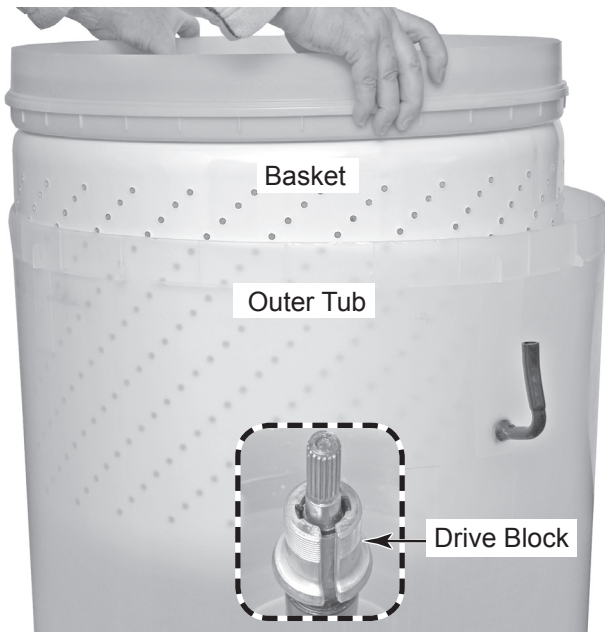

8. **To remove the outer tub:**

- a) Disconnect the end of the water level hose from the side of the outer tub.

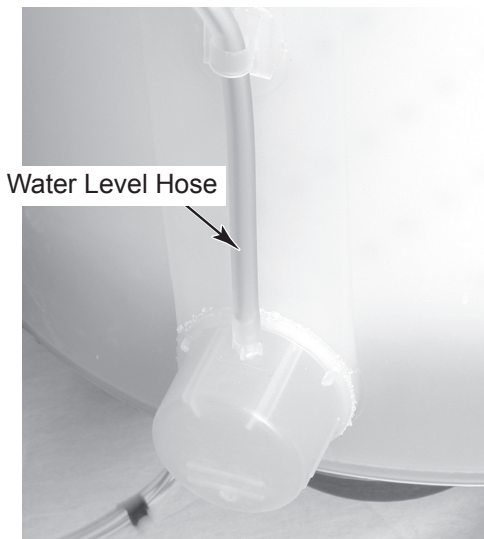

- b) Loosen the clamp and remove the end of the tub-to-pump hose from the bottom of the outer tub (see the top right photo).
- c) Unhook the tub springs from the left and right front tub spring brackets.
- d) Remove the two hex-head screws from the left and right front tub spring brackets and remove the brackets.

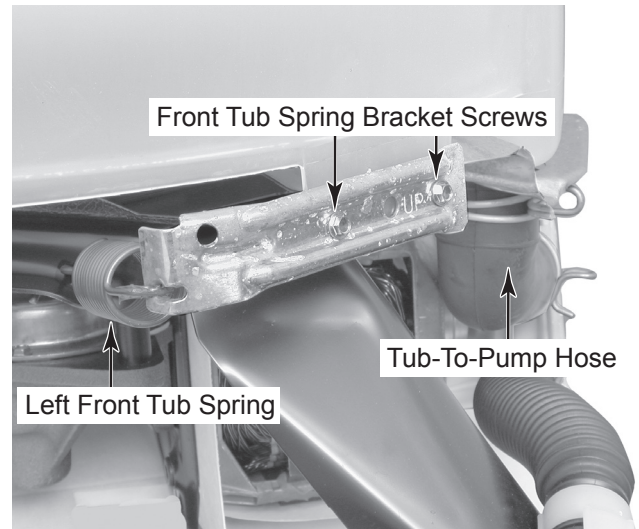

- e) Unhook the counterbalance spring from the rear tub spring bracket and the frame.
- f) Unhook the rear tub spring from the tub spring bracket.
- g) Remove the two hex-head screws from the rear tub spring bracket and remove the bracket.

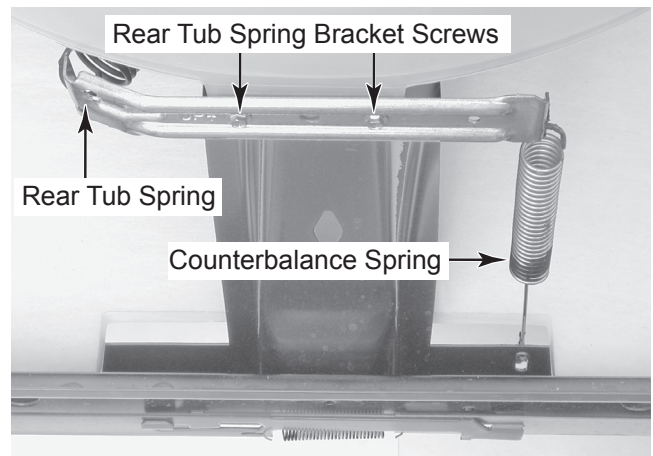

- h) Turn the outer tub while you lift it off the support assembly.

OUTER TUB REASSEMBLY NOTE: When you reinstall the outer tub, install the rear tub spring bracket first.

Continued on the next page.

9. **To remove the basket drive assembly:**
- a) Remove the agitator and transmission (see page 4-12 for the procedures).
 - b) Remove the basket (see step 7).
 - c) Turn the clutch engagement cam on the basket drive in a counterclockwise direction while pulling the cam toward you, and remove the basket drive from the support assembly.

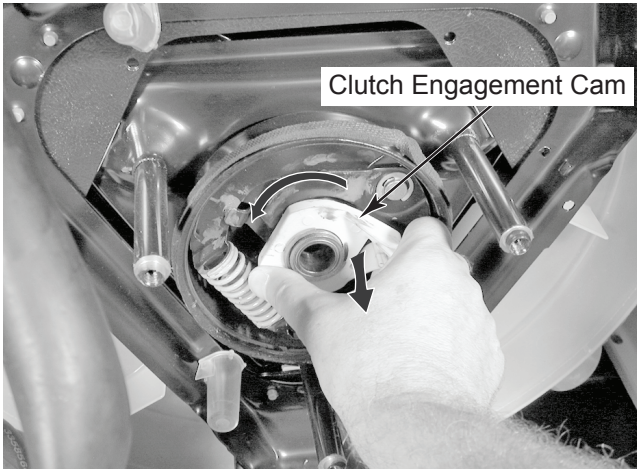

SERVICE NOTE:

- While the basket drive is removed, check for shaft wear, using the procedure shown on page 5-6.

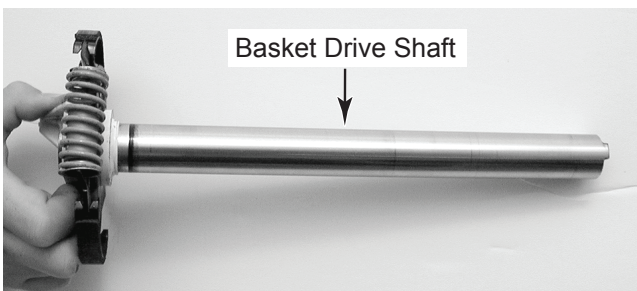

REASSEMBLY NOTES:

1. When you install the drive block on the transmission shaft, make sure that the two slots fit over the tabs of the shaft.

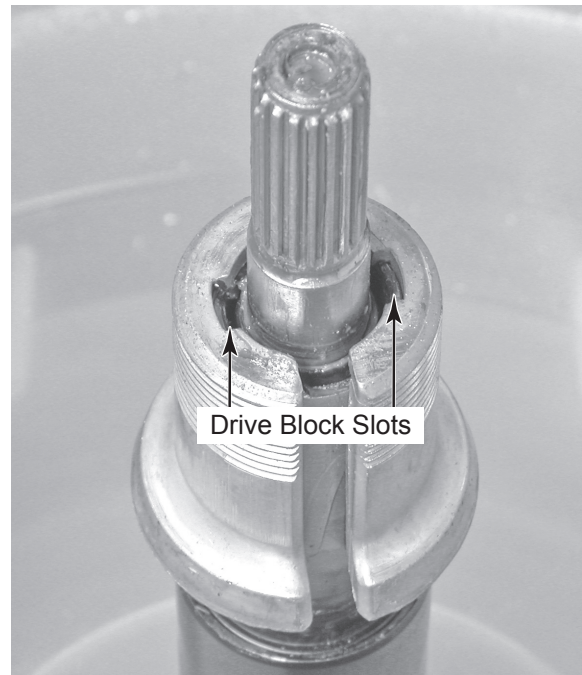

2. When you install the tub ring on the tub, position the ring with the keyed (narrow) locking tab slot, as shown.

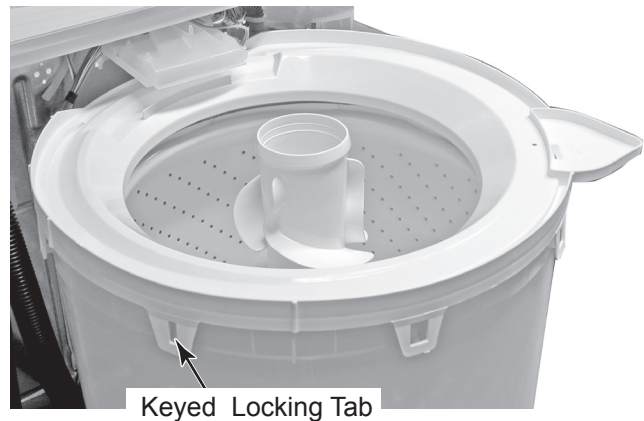

REMOVING THE SKATE PLATE AND SUSPENSION PADS

⚠ WARNING



Electrical Shock Hazard
Disconnect power before servicing.
Replace all parts and panels before operating.
Failure to do so can result in death or electrical shock.

1. Unplug washer or disconnect power.
2. Tilt the cabinet forward and remove cabinet (see page 4-5 for the procedure).
3. Remove the outer tub (see pages 4-16 and 4-17 for the procedure).

4. Lift the skate plate off the base assembly.
5. Pry the three suspension pads off the top of the washer base assembly and replace the pads.

Pry Off Suspension Pads

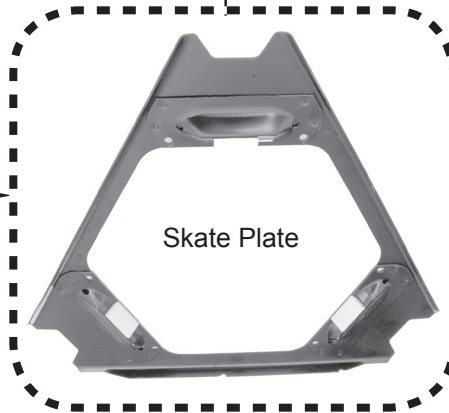
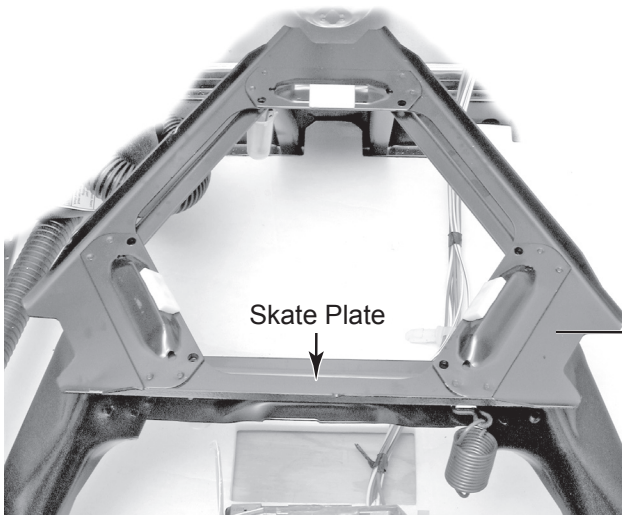
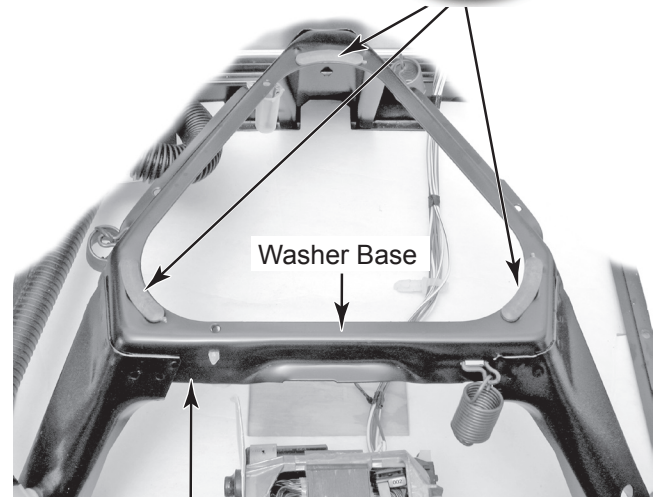
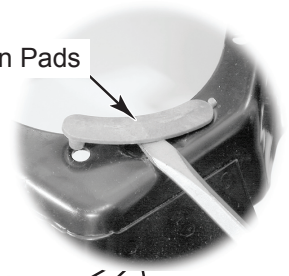

— NOTES —

COMPONENT TESTING

Before testing any of the components, perform the following checks:

- Resistance checks must be made with power cord unplugged from outlet, and with wiring harness or connectors disconnected.
- The most common cause for control failure is corrosion on connectors. Therefore, disconnecting and reconnecting wires will be necessary throughout test procedures.
- All tests/checks should be made with a VOM or DVM having a sensitivity of 20,000 ohms-per-volt DC, or greater.
- Check all connections before replacing components, looking for broken or loose wires, failed terminals, or wires not pressed into connectors far enough.



! WARNING

Electrical Shock Hazard

Disconnect power before servicing.

Replace all parts and panels before operating.

Failure to do so can result in death or electrical shock.

TIMER MOTOR

Refer to page 4-2 for the procedure for accessing the timer.

1. Unplug washer or disconnect power.
2. Disconnect the 2-wire connector from the timer motor terminals.
3. Set the ohmmeter to the R x 10K scale.
4. Touch the ohmmeter test leads to the timer motor terminals. The meter should indicate between 2380 and 2440 Ω .

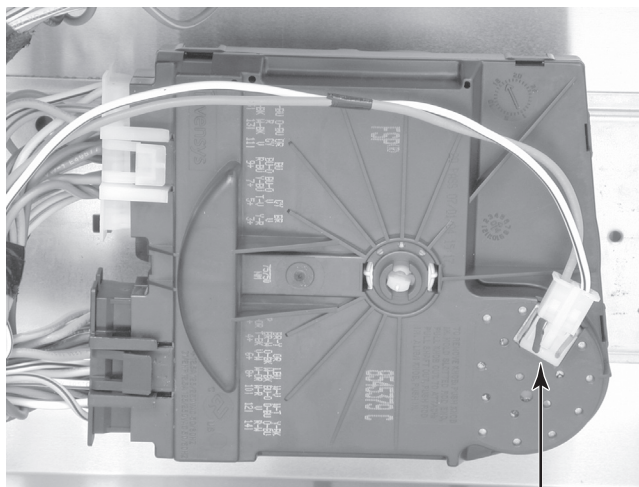

Timer Motor Connector

LID SWITCH (N.O.)

Refer to page 4-4 for the procedure for accessing the lid switch.

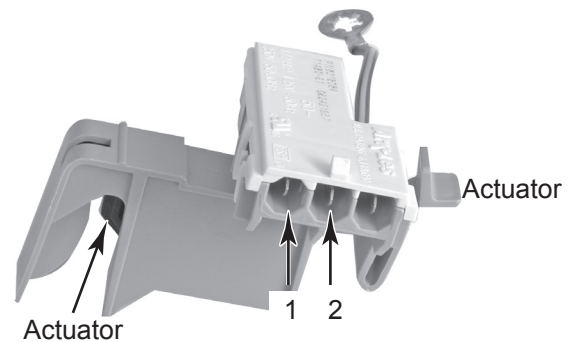

1. Unplug washer or disconnect power.
2. Disconnect the 3-wire lid switch connector from the top of the washer.
3. Set the ohmmeter to the R x 1 scale.
4. Touch the ohmmeter test leads to connector pins 1 and 2. The meter should indicate an open circuit (infinite).
5. With the meter connected as in step 4, press the lid switch actuator. The meter should indicate a closed circuit (0 Ω).



⚠ WARNING

Electrical Shock Hazard

Disconnect power before servicing.
Replace all parts and panels before operating.
Failure to do so can result in death or electrical shock.

WATER LEVEL PRESSURE SWITCH

Refer to page 4-2 for the procedure for accessing the water level pressure switch.

1. Unplug washer or disconnect power.
2. Disconnect the 3-wire connector and the pressure tube from the pressure switch inlet.
3. Set the ohmmeter to the R x 1 scale.

NOTE: To activate the pressure switch, blow into the pressure switch inlet.

4. Touch the ohmmeter test leads to the test points indicated in the Water Level Switch Test Table. The switch should change states when sufficient air pressure is applied to the pressure switch inlet.

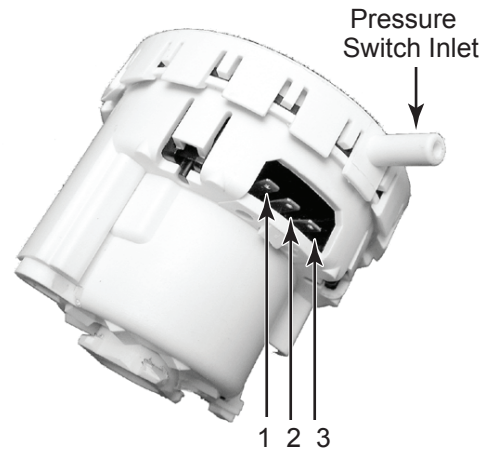

Pin 1 = Full
 Pin 2 = C (Common)
 Pin 3 = Empty

WATER LEVEL SWITCH TEST TABLE

SWITCH	LOCATION	STATE	TEST TERMINALS	WIRE COLORS	READING
WATER LEVEL PRESSURE SWITCH	LEFT SIDE OF CONSOLE	UNDER PRESSURE	C TO EMPTY	V TO P	OPEN
			C TO FULL	V TO T	0-10 OHMS
		NO PRESSURE	C TO EMPTY	V TO P	0-10 OHMS
			C TO FULL	V TO T	OPEN



⚠ WARNING

Electrical Shock Hazard

- Disconnect power before servicing.
- Replace all parts and panels before operating.
- Failure to do so can result in death or electrical shock.

WATER INLET / ATC SENSOR

Refer to page 4-7 for the procedure for accessing the water inlet/ATC sensor.

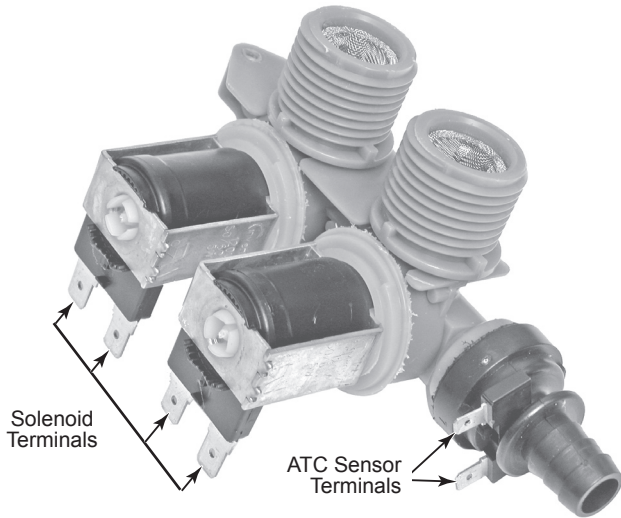

1. Unplug washer or disconnect power.
2. **To test a solenoid coil:**
 - a) Disconnect the solenoid connector from the water inlet you are testing.
 - b) Set the ohmmeter to the R x 1 scale.
 - c) Touch the ohmmeter test leads to the solenoid terminals. The meter should indicate between 740 and 820 Ω .

3. **To test the ATC sensor:**

- a) Disconnect the wires from the sensor terminals.
- b) Touch the ohmmeter test leads to the sensor terminals. The meter should indicate as shown in the following "Sensor Resistance Chart."

SENSOR RESISTANCE CHART	
Temperature (°F)	Resistance (Ohms)
40	126k-135k
50	97k-102k
60	75k-78k
70	58k-61k
80	46k-47k
90	36k-37k
100	28k-30k
110	23k-24k
120	18k-19k
130	15k-16k
140	12k-13k
150	10k-11k



⚠ WARNING

Electrical Shock Hazard

Disconnect power before servicing.

Replace all parts and panels before operating.

Failure to do so can result in death or electrical shock.

MOTOR START CAPACITOR

Refer to page 4-7 for the procedure for accessing the motor start capacitor.



1. Unplug washer or disconnect power.
2. Discharge the capacitor by touching the leads of a 20,000 Ω resistor to the two terminals.

3. Disconnect the wires from the capacitor terminals.
4. Set the ohmmeter to the R x 1K scale.
5. Touch the ohmmeter test leads to the motor start capacitor terminals. The meter should quickly rise to indicate a low resistance, and then gradually fall to indicate a high resistance. To repeat the test, reverse the meter leads. The result should be the same if the capacitor is good.

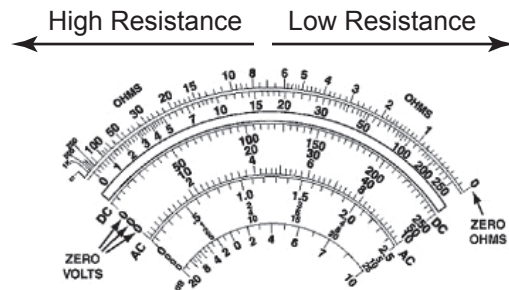



⚠ WARNING

Electrical Shock Hazard

Disconnect power before servicing.
Replace all parts and panels before operating.
Failure to do so can result in death or electrical shock.

MOTOR

Refer to page 4-10 for the procedure for accessing the motor.

1. Unplug washer or disconnect power.
2. Disconnect the plug from the motor connector.
3. Set the ohmmeter to the R x 1 scale.
4. Touch the ohmmeter test leads to the motor lead colors shown in the connector plate. The meter should indicate as shown in the Motor Test Table.
5. Touch the ohmmeter test leads to the following motor switch connections. The meter should indicate as shown in the Motor Switch Test Table.

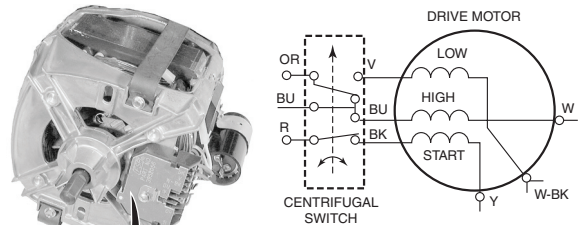

Motor Connector

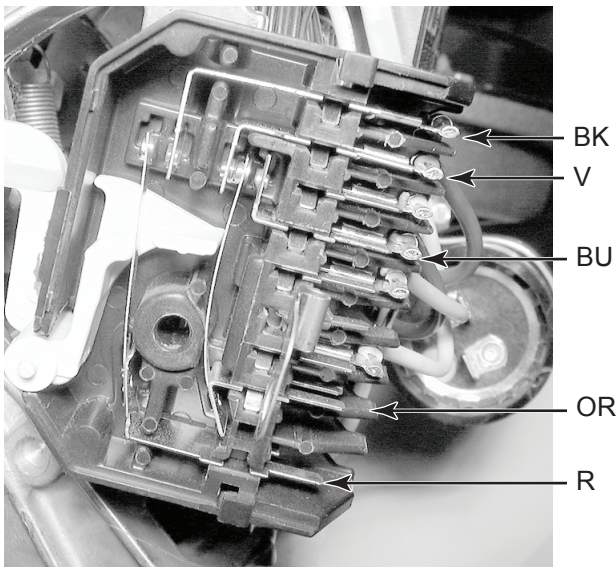
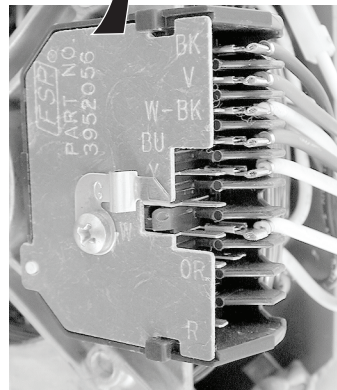

MOTOR TEST TABLE		
FUNCTION	TEST TERMINALS	READING
LOW SPEED	V TO W-BK	18 TO 26 OHMS
HIGH SPEED	BU TO W	1 TO 1.5 OHMS
START WINDING	BK TO Y	5 TO 10 OHMS
THERMAL PROTECTOR	W TO W	0 OHMS

MOTOR SWITCH TEST TABLE		
STATE	TEST TERMINALS	READING
AT REST	R TO BK	1 TO 2 OHMS
	OR TO BU	
	OR TO V	
AT SPEED OR SWITCH ARM RELEASED*	R TO BU	OPEN (INFINITE OHMS)
	R TO BK	
	OR TO BU	
	OR TO V	
	R TO BU	1 TO 2 OHMS

* SWITCH ARM CAN BE RELEASED BY REMOVING THE SWITCH FROM THE MOTOR

⚠ WARNING



Electrical Shock Hazard

Disconnect power before servicing.

Replace all parts and panels before operating.

Failure to do so can result in death or electrical shock.

MOTOR THERMAL PROTECTOR

Refer to page 4-10 for the procedure for accessing the pump and motor.

Motor Thermal Protector

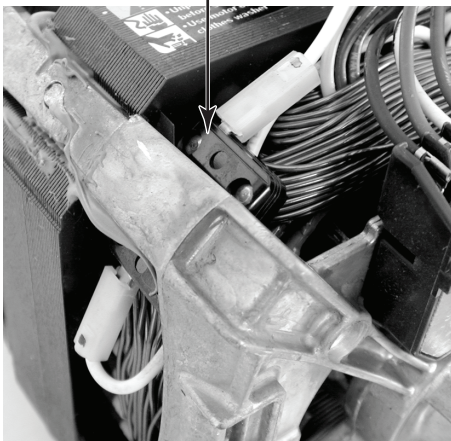

1. Unplug washer or disconnect power.
2. Disconnect one of the wires from the motor thermal protector terminals.
3. Set the ohmmeter to the R x 1 scale.
4. Touch the ohmmeter test leads to the motor thermal protector terminals. The meter should indicate a closed circuit (0 Ω).
5. With the meter connected as in step 4, press the switch actuator. The meter should indicate an open circuit (infinite).

BASKET DRIVE SHAFT CHECKS

Refer to page 4-16 for the procedure for accessing the basket drive.

1. With the basket drive removed, check for excessive wear on the shaft (see the photo below). Excessive wear can be identified by a ridge between the bearing contact surfaces, and the center area of the shaft. If ridges can be felt along the bearing wear areas, and are greater than .005", replace the basket drive.
2. If replacement of the upper and lower center post seals is ever necessary, check for wear ridges on the basket drive shaft. If ridges are present, replace the basket drive.

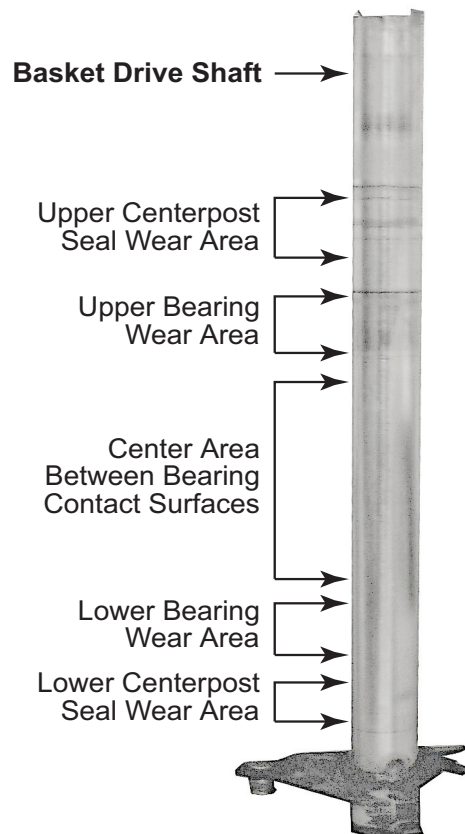

DIAGRAMS AND CHARTS

WIRING DIAGRAM

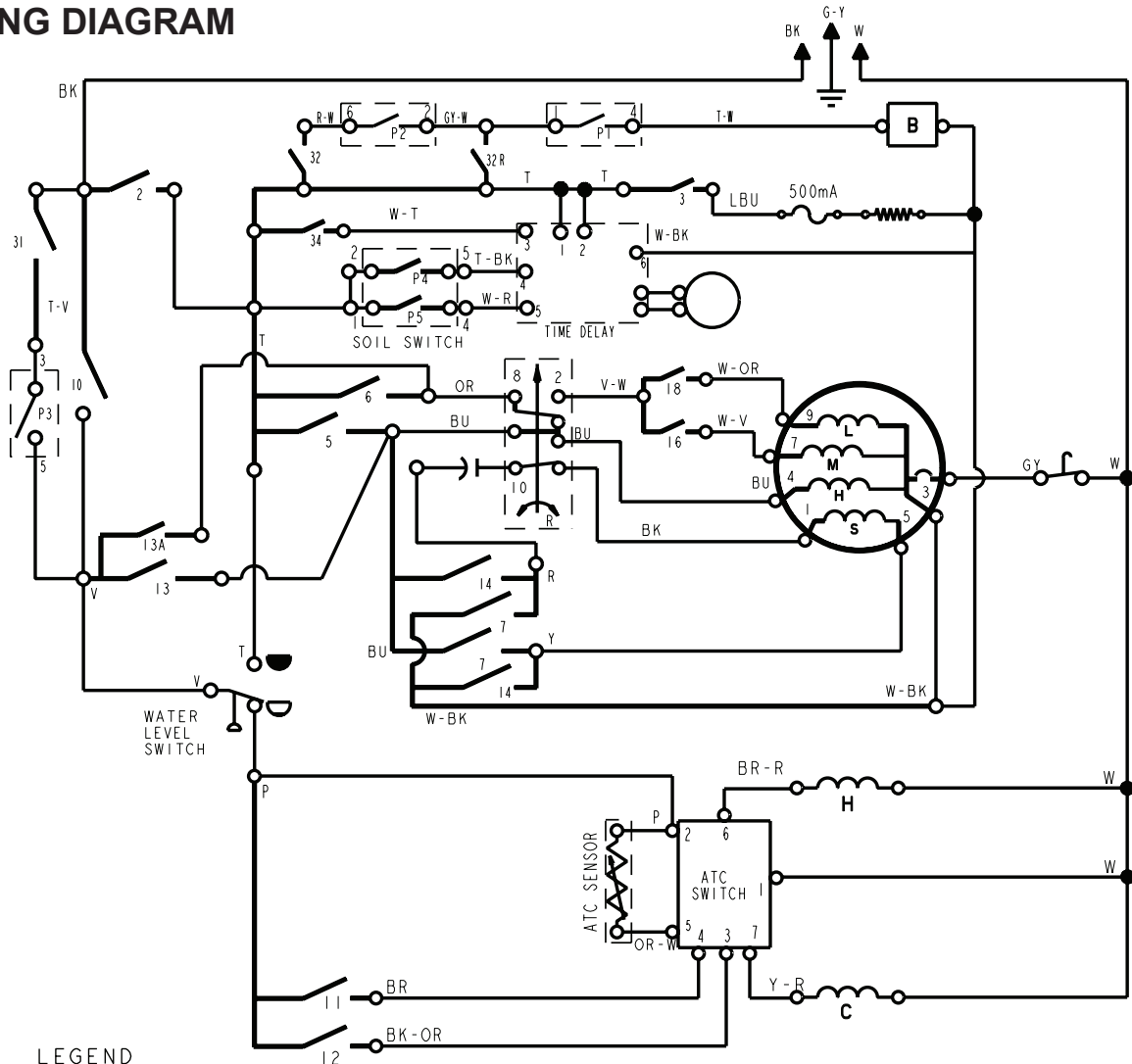

LEGEND

TIMER SWITCH

INT. COMP CONNECTION

HARNESS WIRING

HARNESS CONNECTION

TERMINAL CONNECTION

DRIVE MOTOR
 L LOW
 M MEDIUM
 H HIGH
 S START

HOT VALVE
 H

COLD VALVE
 C

TSC TEMPERATURE SWITCH CHART

BLEACH DISPENSE CIRCUIT
 NOT USED ALL MODELS

WATER LEVEL SWITCH

FULL

EMPTY

LID SWITCH

TIMER MOTOR

CENTRIFUGAL SWITCH

CABINET GROUND

CAPACITOR

TIMER KNOB PUSH OFF ALL TIMER SWITCHES OPEN

TIMER SEQUENCE CHART

154:38

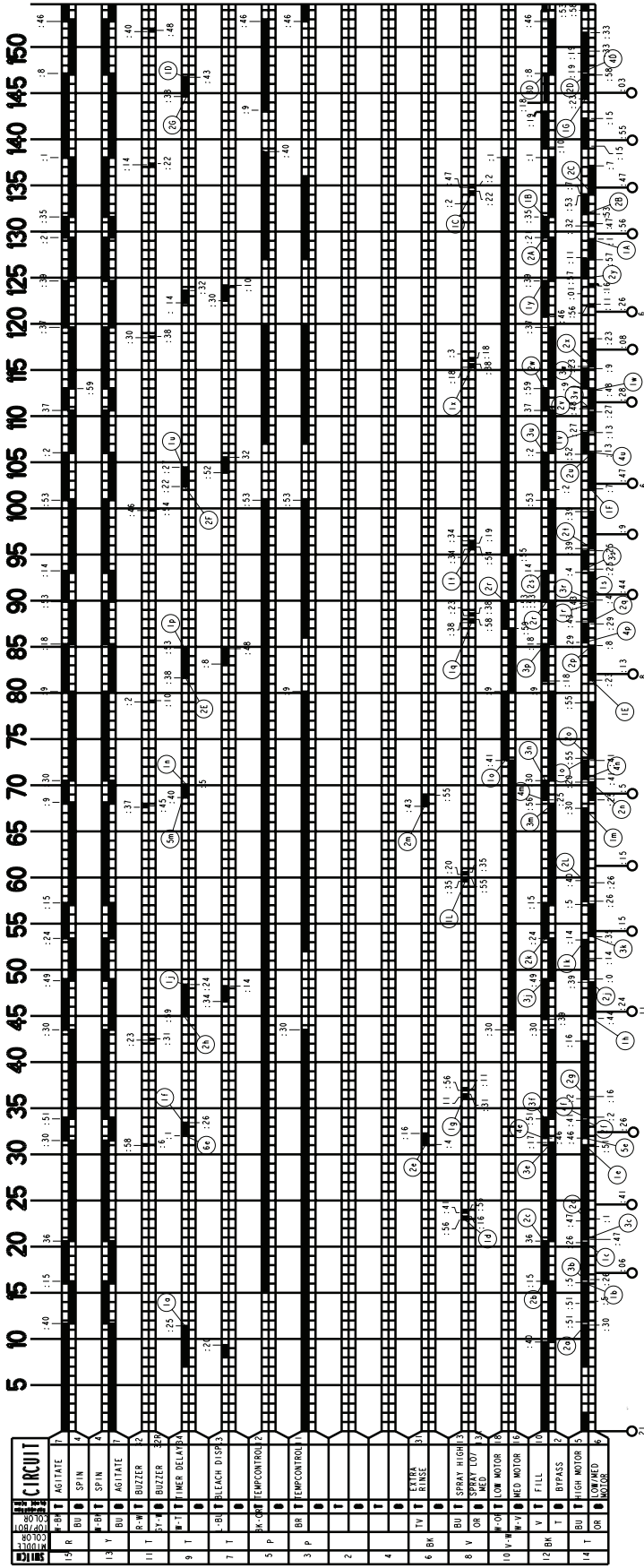

ULTRA CLEAN			EXTRA RINSE			NORMAL			EXTRA RINSE			PERMANENT PRESS			DELICATE			HANDWASH			PREWASH					
SPIN	DRAIN HI	FILL - AGITATE	SPIN	DRAIN HI	FILL - AGITATE	SPIN	DRAIN HI	FILL - AGITATE	SPIN	DRAIN HI	FILL - AGITATE	SPIN	DRAIN HI	FILL - AGITATE	SPIN	DRAIN HI	FILL - AGITATE	SPIN	DRAIN HI	FILL - AGITATE	SPIN	DRAIN HI	FILL - AGITATE	SPIN	DRAIN HI	FILL - AGITATE

ENGLISH	FRENCH	SPANISH
AGITATE	AGITAR	AGITAR
BLEACH	BLANQUEMENT	BLANQUEO
DRAIN	VIDENT	DRENAJ
FILL	REMPLE	LLENAR
HAUT	ALTO	ALTO
INT. AGITATE	AGITER INTERMITTENT	AGITAR INTERMITENTE
LO	BAJO	BAJO
MOTOR	MOTEUR	MOTOR
NORMAL	NORMALE	NORMAL
PERMANENT PRESS	SYNTHETIQUES	PERMANENTE PRENSA

ENGLISH	FRENCH	SPANISH
RINSE	RINCAGE	ACLARACION
SOAK	IMBIBERT	REMOJAN
SPIN	ESSORAGE	VUELTA
WASH	LAVAGE	AEROSOL
PREWASH	PRE LAVAGE	PRE COLADA
1/2 TUB DRAIN	1/2 COVETTE VID	DREN DE LA TINA DEL 1/2
FAB. SOFTNER	RAMOLLISSANT DE TISSU	SUAVIZADOR DE LA TELA
DETERGENT	DETERGENT	DETERGENTE
OFF	ARRET	DE
COOL DOWN	REFROIDISSEZ	REFRESQUESE ABAJO
DRY AGITATE	SECHER AGITER	SECO AGITAN
ULTRA CLEAN	ULTRA PROPRE	ULTRA LIMPIO

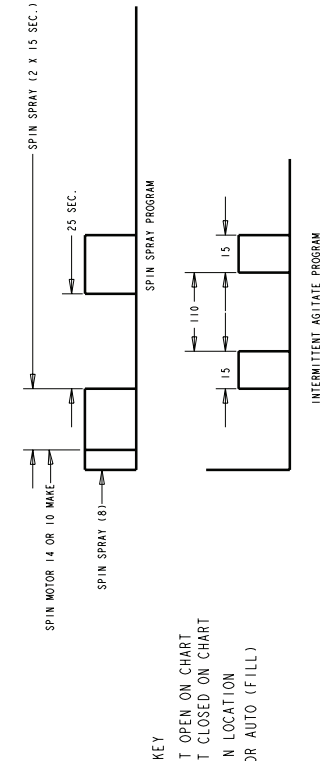

KEY
 CONTACT OPEN ON CHART
 CONTACT CLOSED ON CHART
 DIAL - IN LOCATION
 ## OFF OR AUTO (FILL)

CYCLE CHARTS

SOIL LEVEL SWITCH 8578416		P4	P5
1	LIGHT SOIL		
2	NORMAL SOIL	X	
3	HEAVY SOIL		X

SOAK DELAY W10104800			
SOIL LEVEL	DELAY PATTERN	PIN 4	PIN 5
HEAVY	40 ON 180 OFF		X
NORMAL	60 ON 150 OFF	X	
LIGHT	60 ON 120 OFF		

OPTION SWITCH CHART 3950356					
EXTRA RINSE		BUZZER	P1	P2	P3
1	OFF	OFF		X	
2	ON	OFF			X
3	OFF	ON	X	X	
4	ON	ON	X		X

TSC 8577786		ULTRA CLEAN TEMP	NORMAL / CASUAL TEMP	DELICATE / HAND WASH TEMP	RINSE TEMP
POS	WASH				
1	COLD	COLD	COLD	COLD	COLD
2	COOL	70°	70°	70°	COLD
3	SMART WARM	100°	93°	87°	COLD
4	SMART HOT	HOT	110°	100°	COLD

— NOTES —

— NOTES —

— NOTES —

PRODUCT SPECIFICATIONS AND WARRANTY INFORMATION SOURCES

IN THE UNITED STATES:

FOR PRODUCT SPECIFICATIONS AND WARRANTY INFORMATION CALL:

FOR WHIRLPOOL PRODUCTS: 1-800-253-1301
FOR KITCHENAID PRODUCTS: 1-800-422-1230
FOR ROPER PRODUCTS: 1-800-447-6737

FOR TECHNICAL ASSISTANCE WHILE AT THE CUSTOMER'S HOME CALL:

THE TECHNICAL ASSISTANCE LINE: 1-800-832-7174

**HAVE YOUR STORE NUMBER READY TO IDENTIFY YOU AS AN
AUTHORIZED IN-HOME SERVICE PROFESSIONAL**

FOR LITERATURE ORDERS:

PHONE: 1-800-851-4605

FOR TECHNICAL INFORMATION AND SERVICE POINTERS:

www.servicematters.com

IN CANADA:

FOR PRODUCT SPECIFICATIONS AND WARRANTY INFORMATION CALL:

1-800-461-5681

FOR TECHNICAL ASSISTANCE WHILE AT THE CUSTOMER'S HOME CALL:

THE TECHNICAL ASSISTANCE LINE: 1-800-488-4791

**HAVE YOUR STORE NUMBER READY TO IDENTIFY YOU AS AN
AUTHORIZED IN-HOME SERVICE PROFESSIONAL**

