

**MAYTAG**

# **Maytag Commercial**

## **Washer Service Manual**

16002035  
Issued 11/93  
Revised 4/98

---

## GENERAL SAFETY PRECAUTIONS

Information contained in this manual is intended for use by a qualified service technician familiar with proper and safe procedures to be followed when repairing an electrical appliance. All tests and repairs should be performed by a qualified service technician equipped with proper tools and measuring devices. All component replacements should be made by a qualified service technician using only factory approved replacement parts.

Improper assembly or adjustment may occur if service or repair is attempted by persons other than qualified service technicians or if parts other than approved replacement parts are used. Improper assembly or adjustment can create hazardous conditions.

There can be risk of injury or electrical shock while performing services or repairs. Injury or electrical shock can be serious or even fatal. Consequently, extreme caution should be taken when performing voltage checks on individual components of a product. Except as necessary to perform a particular step in servicing a product, the electrical power supply should **ALWAYS** be disconnected when servicing a product.

Further, this appliance **MUST** be properly grounded. Never plug in or direct wire an appliance unless it is properly grounded and in accordance with all local and national codes. See installation instructions that accompany the product for grounding this appliance.

---

# Contents

<b>SECTION 1. GENERAL INFORMATION</b> .....	1-1
TERMINOLOGY AND DEFINITIONS .....	1-1
HOW IT WORKS .....	1-3
FILL .....	1-3
Water Valve (Non-Thermostatic) .....	1-3
Water Level Control (Pressure Switch) .....	1-4
DRIVE MOTOR .....	1-5
HELICAL DRIVE .....	1-5
Agitation .....	1-6
Spin .....	1-7
DEPENDABLE DRIVE TRANSMISSION .....	1-8
ELECTRICAL TEST EQUIPMENT .....	1-8
Appliance Test Meter .....	1-8
Voltage Checks .....	1-10
Clamp-On Ammeter .....	1-10
Grounding & Polarity .....	1-11
Motor Test Cord .....	1-12
<b>SECTION 2. SERVICE PROCEDURES</b> .....	2-1
CONTROL CONSOLE .....	2-1
MN (Manual) Models .....	2-1
CS (Coin Slide) Models .....	2-2
DA (Data Acquisition) Models .....	2-2
TIMER .....	2-3
Timer Off Position Indicator .....	2-4
Rinse Time Selection .....	2-4
PD (MICROPROCESSOR/DATA ACQUISITION) MODELS .....	2-4
MICROPROCESSOR .....	2-4
Touch Pad Assembly .....	2-5
CYCLE SELECTOR SWITCH .....	2-6
CONTROL TRANSFORMER .....	2-6
VARISTOR (MOV-METAL OXIDE VARISTOR) .....	2-7
MOTOR RUN RELAY .....	2-7
MOTOR REVERSING RELAY .....	2-8
INDICATOR LIGHTS .....	2-9
LID SWITCH ASSEMBLY .....	2-9
MN and CS Models .....	2-10
Lid Closed .....	2-10
Opening The Lid .....	2-10
Lid Switch Failure .....	2-11
DA (Data Acquisition) Models .....	2-11
PD (Microprocessor/Data Acquisition) Computer Trac II Models .....	2-11
WATER LEVEL PRESSURE SWITCH .....	2-11

Water Level Adjustment .....	2-13
AIR TUBE AND DOME .....	2-13
WATER VALVE .....	2-14
WATER INJECTOR ASSEMBLY .....	2-14
METER CASE .....	2-15
COIN SLIDE .....	2-15
COIN DROP ACCEPTOR .....	2-16
COIN SENSOR .....	2-17
SERVICE DOOR & COIN VAULT MONITOR SWITCHES .....	2-18
LID .....	2-18
TOP COVER .....	2-19
TUB COVER .....	2-20
BALANCE RING .....	2-20
AGITATOR .....	2-21
ACCESS PLUGS .....	2-21
CENTER SHAFT SEAL .....	2-22
INNER TUB .....	2-22
Tub Centering .....	2-23
MOUNTING STEM AND BOOT SEAL .....	2-24
OUTER TUB .....	2-26
TUB BEARING .....	2-27
DEPENDABLE DRIVE TRANSMISSION .....	2-27
LIP SEAL .....	2-32
DAMPER ASSEMBLY .....	2-33
Damper Pads .....	2-33
Damper Replacement .....	2-34
BRAKE PACKAGE AND RADIAL BEARING .....	2-35
DRIVE PULLEY AND ROTOR BEARING .....	2-37
BELT GUARD .....	2-38
POLY PUMP .....	2-39
PUMP BELT .....	2-39
DRIVE MOTOR AND MOTOR BASE .....	2-39
Motor Ground Wire .....	2-40
Motor Shield .....	2-40
Motor Tension Springs .....	2-42
<b>SECTION 3. SET-UP AND PROGRAMMING PROCEDURES .....</b>	<b>3-1</b>
"PD" CONTROL SET-UP PROCEDURE .....	3-1
How to Read the Display .....	3-1
How to Use the Key Pads to Program the Controls .....	3-1
START OPERATING SET-UP .....	3-2
SET-UP CODES .....	3-2
WASHER DIAGNOSTIC MODE .....	3-7
FAULT CODES .....	3-8
GENERAL USER INFORMATION .....	3-8
"DA" SET-UP & USE INSTRUCTIONS .....	3-8
SET-UP .....	3-8
BATTERY CONNECTION .....	3-9

SWITCH SETTINGS .....	3-10
Washer Coin Settings .....	3-10
OPERATIONAL INSTRUCTIONS .....	3-12
How to Use .....	3-12
GENERAL INFORMATION .....	3-12
<b>SECTION 4. TROUBLESHOOTING .....</b>	<b>4-1</b>
MECHANICAL TROUBLESHOOTING .....	4-1
Vibration Noise .....	4-1
Operation Noise .....	4-1
Water Leaks .....	4-1
Oil Leaks .....	4-1
Failure To Agitate Or Spin .....	4-1
Poor Spin Out .....	4-1
Spins and Agitates At Same Time .....	4-1
Freewheeling Inner Tub .....	4-2
Timer Shaft Hard To Pull Out (MN Model) .....	4-2
Warm Water Temperature Too Cold .....	4-2
Slow Fill .....	4-2
Water Siphoning Out Of Washer .....	4-2
ELECTRICAL TROUBLESHOOTING .....	4-2
Washer Won't Fill (MN Models) .....	4-4
Washer Won't Fill (CS & DA Models) .....	4-5
Washer Won't Run - Agitate (MN Models) .....	4-6
Washer Won't Run - Agitate (CS & DA Models) .....	4-7
Washer Won't Spin (MN, CS, and DA Models) .....	4-8
DA TROUBLESHOOTING .....	4-9
PD TROUBLESHOOTING .....	4-30
<b>SECTION 5. SPECIFICATIONS AND WIRING SCHEMATICS .....</b>	<b>5-1</b>
GENERAL SPECIFICATIONS .....	5-1
WATER CONSUMPTION .....	5-2
Model MAT11MN, MAT11PD .....	5-2
Model MAT10CS, MAT10DA, MAT10PD .....	5-3
CYCLE CHART .....	5-4
Models MAT10CS, MAT10DA, MAT11MN .....	5-4
Model MAT10PD, MAT11PD .....	5-6
WIRING SCHEMATIC - MAT10CS .....	5-8
WIRING SCHEMATIC - MAT10DA .....	5-9
WIRING SCHEMATIC - MAT10PD, MAT11PD .....	5-10
WIRING SCHEMATIC - MAT11MN .....	5-11

**Models Covered:**

**MAT10CS  
MAT10DA  
MAT10PD  
MAT11MN  
MAT11PD**

---

# INTRODUCTION

This manual is divided into four sections covering the Maytag top load commercial washer. Refer to these sections for general information or contact your commercial distributor or route operator.

**SECTION 1** covers general information, terminology, definitions, how the machine works, and electrical test equipment.

**SECTION 2** will provide information on location of components and service procedures. The purpose and functions of specific components will be covered.

**SECTION 3** covers set up and programming procedures for machines with micro-processors.

**SECTION 4** covers electrical and mechanical troubleshooting along with a list of some general complaints.

**SECTION 5** covers specifications, cycle charts, and wiring schematics.

**Note:**

Model	
Serial Number	
Installation Date	

**My Distributor is:**

Company Name	
Address	
City, State	
Zip Code	
Person to Contact	





---

# SECTION 1. GENERAL INFORMATION

---

## TERMINOLOGY AND DEFINITIONS

---

TERMS	DEFINITION
AMPERAGE	The amount or the rate of flow of electrical current.
CAM	A notched disc within the timer. As the disc turns, the notches open and close switches in the timer to provide the proper operating sequences.
CENTRIFUGAL SWITCH	A switching device in a motor used to change the path of electricity from both start and run winding to run winding only once the motor reaches running speed.
CHECK SWITCH	Secondary lid switch.
COIN SLIDE	A device which accepts a specified number and denomination of coins to start the washer.
CONTINUITY	A continuous or unbroken path for the flow of current through an electrical component.
CONTROL CENTER	A enclosure which holds the controls that start the washer.
CS WASHER	Coin slide washer.
CYCLE	The complete sequence of electrical and mechanical functions to complete the fill, wash and spin sequences as set by the timer.
DA WASHER	Data Acquisition (Accu-trac) washer.
DRIVE LUG	A lug splined to the drive shaft which is contacted by the drive pulley lug and then turns the drive shaft going to the power unit to provide agitation.
GLIDES	Square wheel type components used on the motor base allowing the motor and motor pulley to move.
HELICAL DRIVE	Principal of mechanical drive used on the Maytag washer to provide spin and agitation drive to the transmission.

<b>TERMS</b>	<b>DEFINITION</b>
<b>LID SWITCH</b>	Component that stops operation of the washer when the lid is raised.
<b>LINE SWITCH</b>	Manually operated on-off electrical switch in the timer that supplies current to the timer when the timer knob is pulled out.
<b>MN WASHER</b>	Mechanical non-coin washer.
<b>O.P.M.</b>	Oscillations per minute.
<b>OVERLOAD PROTECTOR</b>	A bi-metal actuated switch in the motor which reacts to temperature and will stop the motor if overheating occurs.
<b>PD WASHER</b>	Processor-based Data Acquisition washer.
<b>P.S.I.</b>	Pounds per square inch.
<b>RELAY</b>	An electrical switching device that allows low power control circuits to switch high power motor circuits.
<b>RUN WINDING</b>	The main electromagnetic winding in a motor.
<b>START WINDING</b>	(Phase winding.) An auxiliary winding used in an AC motor to assist the main winding in developing starting torque.
<b>SELECTOR SWITCH</b>	A mechanical switch package located on the control panel.
<b>SOLENOID</b>	An electromagnetic component used to activate components such as the water valve.
<b>STANDPIPE</b>	Vertical pipe (part of the drain system) used for draining water from the washer. (Should be 36" from floor.)
<b>SIPHON BREAK</b>	Component installed to the drain hose to prevent water siphoning out of or into the washer.
<b>TUB BLOCK</b>	Device used to secure inner tub during shipment or handling.
<b>TIMER</b>	An electromechanically driven switch package. It controls various washer functions in a predetermined sequence.
<b>TIMER MOTOR</b>	Electrical device on the timer which advances timer through its operating sequence.
<b>TRANSMISSION</b>	Power unit used to change rotary motion into back and forth agitation motion.
<b>WATTAGE</b>	A unit of measurement of the capability of electricity to do work.
<b>WATER VALVE</b>	A device controlling the water entering the washer.

## HOW IT WORKS

The "cycles" are made up of three basic operations: fill, agitate and spin/drain. These operations are sequenced by the controls (timer or microprocessor board) to provide a proper cleaning cycle for each of several different fabrics.

### FILL

Pressurized hot and cold water supplies are required. The "dynamic", or flow pressure should be between 30 lbs. per square inch and 80 lbs. per square inch. Pressures below 20 lbs per square inch may not allow the water valve to close reliably. Pressures above 80 lbs. per square inch may cause water line hammering.

Hot water is described to be 140°F and cold water temperature should be 75°F. A 50-50 mix of hot and cold should result in warm temperatures between 100°F and 105°F.

The components involved in a fill operation are the water valve assembly, the water level control and the timer or control board. The control board or timer along with the dial-a-fabric switch tell the valve whether to allow hot, cold or both (warm) into the washer. The water level control (also called pressure switch) controls the level of the water in the washer. It should be at the top row of the holes (perforations) in the washer basket plus or minus 1/4 inch.

## Water Valve (Non-Thermostatic)

The water valve used on the Maytag top load washers is designed to operate within a pressure range of 30 to 120 per square inch. Flow pressure cannot fall below 20 p.s.i. or valves may fail to close when solenoids are de-energized.

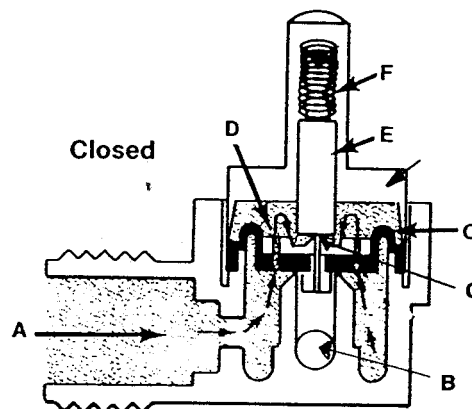

Water from source enters valve at inlet (A) and pushes up on diaphragm (C). The solenoid plunger (E) and the plunger spring (F) are not strong enough to hold the diaphragm in a closed position. The diaphragm is lifted and some water will flow under the diaphragm and into the outlet (B).

Some water also flows through bleeder holes (D) in the diaphragm and into the guide tube area behind the diaphragm. With the solenoid not energized, the plunger (E) would block the pressure release hole (G) allowing the guide tube area to pressurize to source pressure. This causes the diaphragm to be pushed against the valve seat blocking the valve seat and closing the outlet.

While there is equal pressure (source pressure) on both sides of the diaphragm, the pressure in the guide tube area covers a greater surface area

of the diaphragm. The center (outlet area) on the bottom side of the diaphragm is at atmospheric pressure so the valve remains closed. It is important to understand that water pressure is the operating force in the water valve.

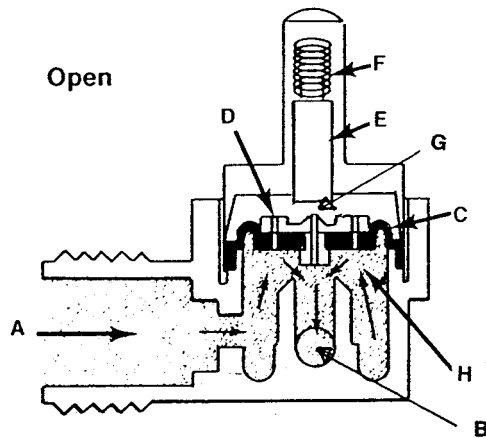

When the valve operating solenoid is energized, a magnetic field is produced that lifts the plunger (E) away from the pressure release hole (G) in the center of the diaphragm. The pressure in the guide tube area is released through hole (G) allowing the inlet pressure to lift the diaphragm (C) off of the outlet seat. Water flows under the diaphragm and out through the valve outlet (B).

Because the bleed holes cannot allow water into the guide tube area as rapidly as it can escape out through the pressure release hole, the diaphragm will remain in the open position as long as the plunger is held away from the release hole.

When the plunger is released (solenoid coil de-energized), it again blocks the release hole allowing pressure entering through the bleed holes to again force the diaphragm back against the outlet seat, stopping the flow of water. A nozzle arrangement at the center of the

diaphragm causes the valve closure to be gradual and smooth to reduce the chance of water line hammer as the valve closes.

## Water Level Control (Pressure Switch)

The water level switch is a single pole, double throw switch which is activated by an air pressure increase against a sealed diaphragm. An air hose is connected to a spout at the bottom of the outer water container (outer tub) and to an inlet spout at the water level control body.

As water enters the tubs and the water level raises, air is trapped the air dome at the bottom of the pressure switch hose. As the water level increases, this air is pushed up the hose and against the diaphragm in the water level control body.

The control is designed to cause the contact points to switch when the water level in the wash basket (and the outer container) reach a particular level. At that point the fill circuits are disconnected and the motor circuit is energized. This corresponds to empty = fill and full = run.

Air leaks at the hose connections cannot be tolerated for proper operation of the water level control.

A bypass circuit is provided by the timer and selector switch to continue power to the motor in spin operations. Without the bypass, the drive motor would stop when sufficient water had been pumped out of the washbasket to cause the pressure switch to reset to the "empty" position.

## DRIVE MOTOR

When the water level / pressure switch is satisfied, circuits are completed to the main drive motor. The drive motor is a special high torque split-phase, four pole motor. Two windings are used. The run winding is designed for full time use in wash and spin. A second winding, called the auxiliary or "start" winding, is used to provide starting torque and determines direction of rotation. A centrifugal switch is mounted to the upper end bell of the motor and serves to disconnect the start winding as the motor reaches running speed.

Contact sets in the timer or in a motor reversing relay provide proper connections to the motor to cause it to run clockwise in agitate and counterclockwise in spin (view from the top).

The drawings show how the timer or reversing relay contacts change the start winding connections to start the drive motor clockwise (viewed from top) for agitation and counterclockwise for spin.

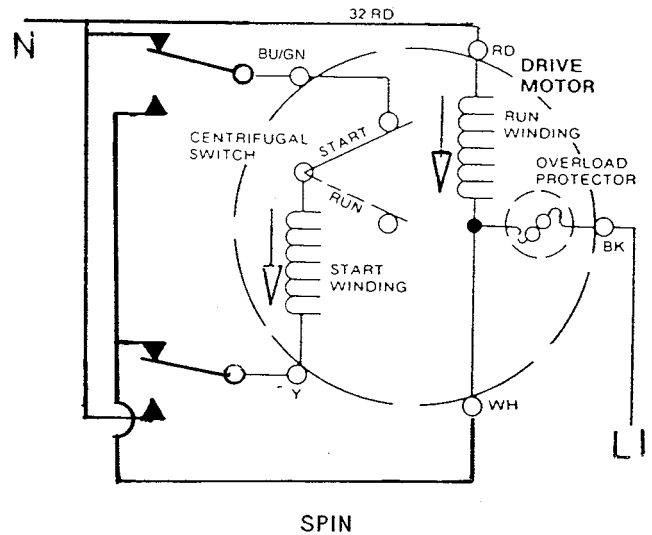
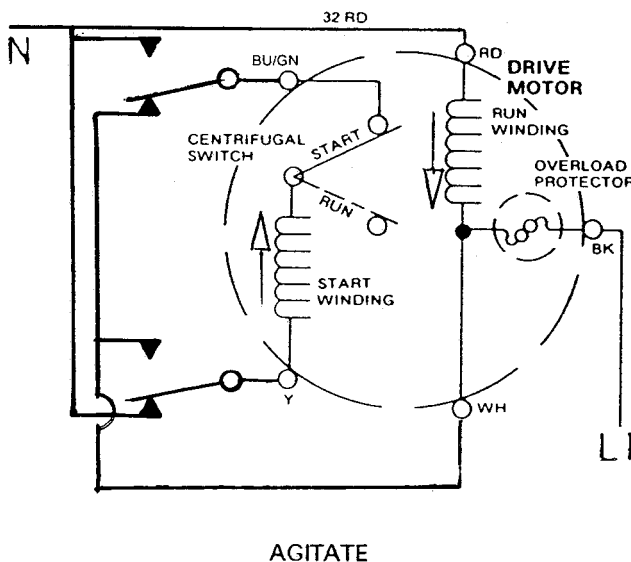

The motor drives the power unit by means of a special design "V" belt.

## HELICAL DRIVE

The helical drive mechanism used on the Maytag washer is simple - not requiring a special device or linkage to shift the washer from agitation to spin.

As you look at the following drawings, keep in mind that the parts shown in dark; the damper, brake housing, brake drum and outer race of the spin bearing are attached to the base and never rotate.

The drive mechanism utilizes a reversible motor and helical (threaded) drive shaft. A pulley which is threaded to the helical drive shaft moves either up or down the shaft dependent upon the direction it is turned by the drive motor by means of a drive belt.

## Agitation

With the pulley (A) being turned as indicated in the following drawing, it moves down the helical drive shaft (B). As it rotates down the shaft, a lug (C) on the pulley comes against a drive lug (D) which is splined to the helical drive shaft.

At this point the drive shaft turns with the pulley. The pulley bearing (E) which is merely resting on top of the pulley also rotates with the pulley, drive lug and helical drive shaft.

At the top of the drive shaft is a splined gear. As it rotates it drives a series of gears causing the agitator to move back and forth in an arc creating the water action for the wash.

The tub and transmission are locked in place and cannot turn because the brake rotor (G) and brake shoe (H) which is splined to the transmission is being held down against the brake drum (I) by the brake spring (J).

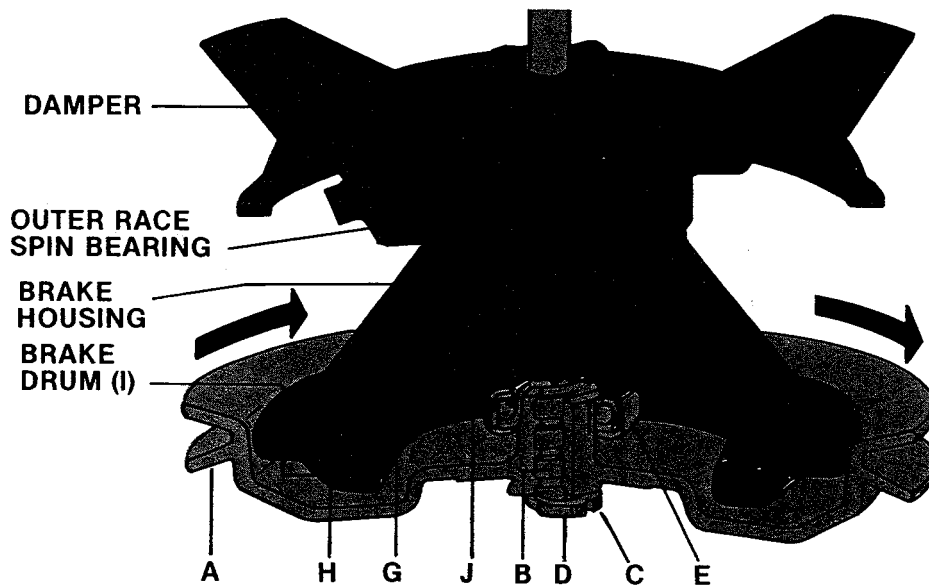

## Spin

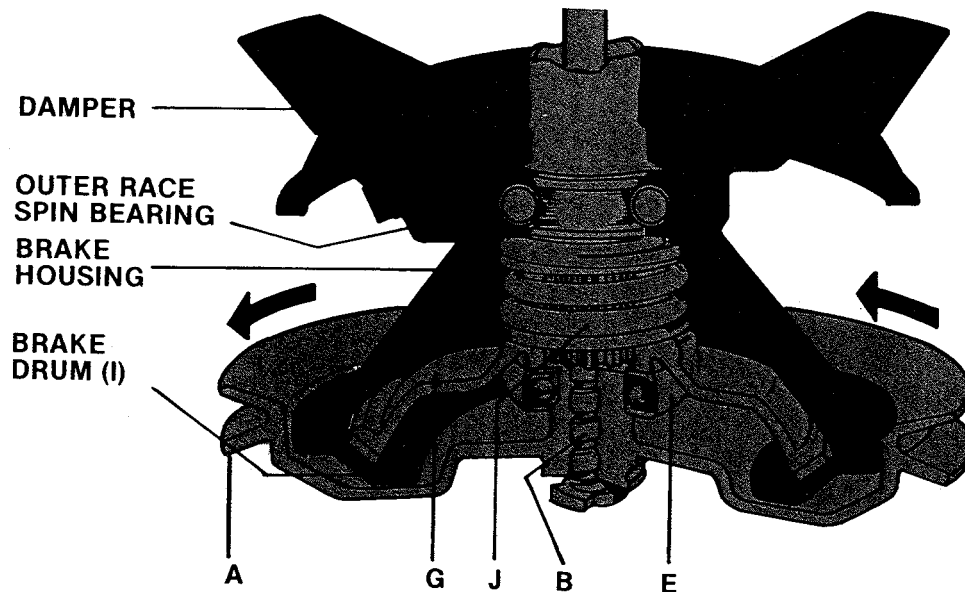

When the motor reverses, the pulley will turn in the direction opposite the previous drawing. This causes the pulley (A) and bearing (E) to turn. The pulley climbs the threads on the helical drive shaft (B) overcoming the force of the brake spring (J) and lifts the brake rotor (G) and brake shoe off the brake drum (I).

As the pulley climbs the shaft and overcomes the force of the brake spring, there is a downward pull on the shaft.

Within the transmission there are two washers which act as a spin clutch. This is a friction clutch consisting of a bronze washer which is splined to and

turns with the drive shaft. Between this washer and the pinion gear is a steel washer which is locked to the transmission case.

As the helical shaft is pulled downward, the two clutch washers under the pinion are forced together. This is done rapidly and slippage occurs only during the first two or three revolutions, until the film of oil between the two clutch washers is forced out.

The drive occurs when the washers are forced together and the pulley has climbed the shaft as far as it can. The driving force has locked the pulley, brake rotor, drive tube and gear case

together and all will turn as a unit in the same direction as the pulley is turning, causing the tub to spin in a counter-clockwise direction (as viewed from the top).

### **SPIN CYCLE COMPLETED**

When the washer reaches the end of the spin cycle, the drive force is removed. Thus, there is no force supplied to lock the components together or to compress the brake spring. Therefore, the downward force of the brake spring effectively reverses all the actions outlined above.

---

### **DEPENDABLE DRIVE TRANSMISSION**

The helical drive shaft drives a pinion gear which is splined to the top of the drive shaft at approximately 618 r.p.m. This drives the bevel gear at approximately 150 r.p.m.

The pivot pin of the yoke portion of the torque block and yoke assembly is driven in a circular motion (orbit) around an imaginary center point of the bevel gear center axis. The yoke drives the torque block back and forth through an arc of approximately 97 degrees at the rate of about 150 times per minute.

Splines on the bottom of the agitator drive shaft mesh with splines at the top of the torque block. The agitator is driven through a 97 degree arc at about 150 oscillations per minute. Because this is a continuous motion, the drive provides very smooth operation. The reduction in parts results in improved dependability. This gear case can be

serviced without removing it from the washer.

---

### **ELECTRICAL TEST EQUIPMENT**

The equipment required to service Maytag products depends largely upon the condition encountered. Locating a malfunction will often require the use of electrical testing equipment such as:

- Appliance Test Meter
- Clamp-on Ammeter
- Motor Test Cord

---

#### **Appliance Test Meter**

An Appliance Test Meter is a multi-purpose tester combining an AC-DC voltage tester with a multi-range ohmmeter.

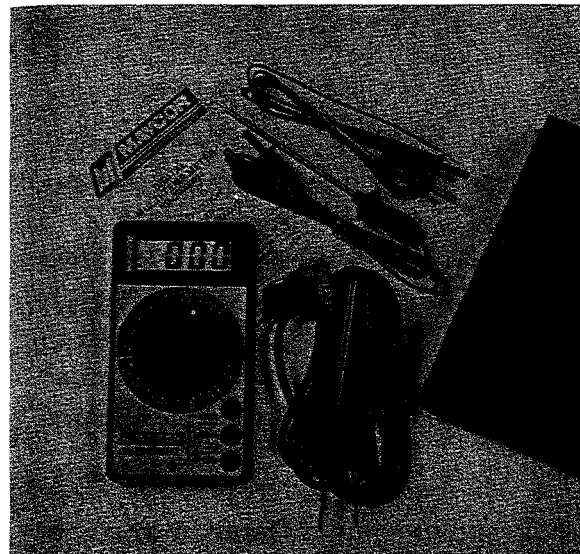

Probably the easiest means of testing electrical components is "continuity testing" with an appliance test meter. Continuity is a complete or continuous path from one point in an electrical circuit to another point.



The obvious advantages of being able to check electrical components and circuits without power applied is one of the features of the ohmmeter. Multiple ranges allow accurate determination of resistances of both single components and entire circuit paths. Resistance is measured in "ohms".

#### SET METER FOR USE AS FOLLOWS:

1. Calibrate meter by touching test probes together and turning adjusting dial until meter reads "0" on the ohm scale. Recheck calibration whenever adjusting dial for ohms settings is changed. (Replace battery if adjustment will not bring meter reading to "0".)
2. Select the scale most easily read and place test probes on respective terminals. When checking a switch, the reading would normally be either open or closed. A reading of 70 on the R x 10 scale would for example be 700 ohms resistance.

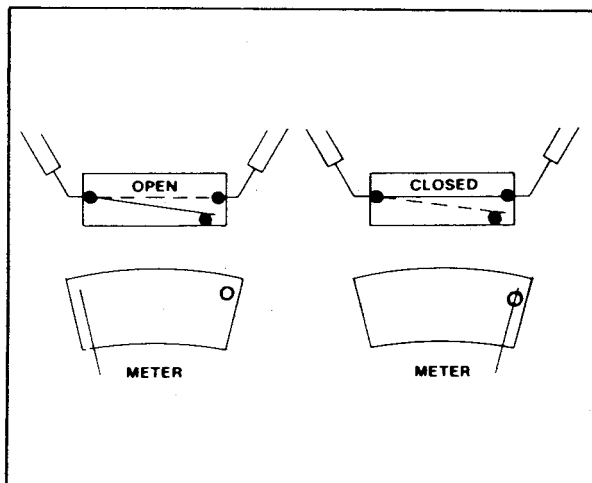

#### CAUTION

Always be sure the power has been disconnected before making resistance measurements. Failure to do so will result in damage to your meter! Internal batteries provide all the power needed to make resistance checks. They should be checked at least once a year and replaced as needed.

For the most part, we will only be concerned with continuity. Is there a path or not? References are made between a "closed" (continuity) reading and an "open" (no continuity) reading. One note, when you get an "open" reading, try a higher resistance range (setting). A very high resistance appears as an "open" on the lower ranges. For best accuracy always "re-zero" meter when changing ranges and/or the physical position of the meter.

Continuity testing, as related to an electrical component, is the check of a part for an "open" or "closed" circuit.

Electrical components fall into two general categories.

1. **LOADS** - Devices that **use** or consume electricity. Examples would include drive motor, timer and solenoid coils.
2. **SWITCHES** - Devices that **control** the supply of electricity to the load or loads in a circuit. Examples include lid switches, timer contacts, selector switch and relay contacts.

Continuity tests of "load" devices will show varying levels of resistance from very low for some transformer and motor windings to very high for some timer motors and components on

control boards. Usually it is more important to know if there is a path for current flow through a device (continuity) than to know the exact resistance (ohms) of the device.

Continuity tests of switches will show virtually no resistance across closed contacts. Resistance, even low values indicates burned or dirty contacts in a switch.

Continuity testing is a process of eliminating those electrical components involved in a given function of the appliance, until the inoperative part is found. By reviewing the list of possible electrical problems under a given condition, and then performing appropriate continuity checks on the parts involved, you should be able to locate the electrical component which is inoperative.

When checking components or circuit paths for continuity, external wiring should be disconnected to eliminate false readings through external paths. Isolate what you want to test.

---

## Voltage Checks

For the most part these checks will consist of taking readings at the wall receptacle in order to determine the availability of voltage to the product. **Extreme caution should be taken when performing voltage checks on individual components of a product due to the possibility of electrical shock.** Component part testing is best accomplished through continuity checks with an Appliance Test Meter.

**Note:** Use of the meter on voltage higher than the indicated range may cause permanent damage to the meter.

To prevent damage, first select highest range and then lower the range for readings which fall within the lower scale. Also, be sure the meter is set correctly for the type of voltage being checked (AC or DC).

---

## Clamp-On Ammeter

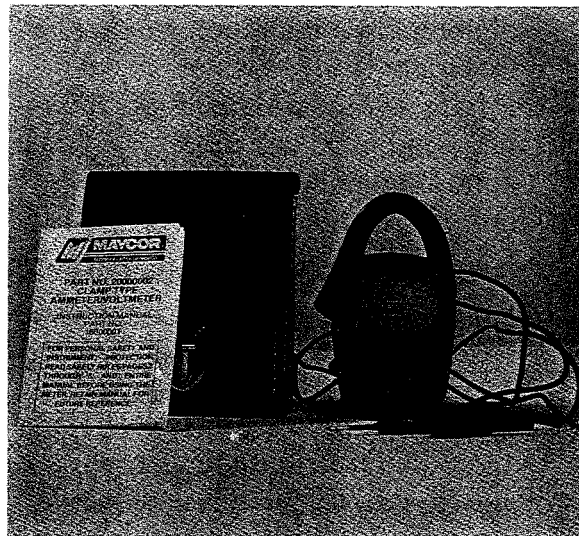

Each circuit in an appliance has a “normal” current draw which is an indication of the performance of that circuit. Current draw levels, less than or more than normal, give clues to malfunctions. The clamp-on ammeter measures these currents without breaking the circuit by measuring the strength of the magnetic field developed around each conductor. Current is read by separating the conductors and clamping the jaws of the ammeter around each conductor on which current is to be read.

**Note:** Overloads on a circuit breaker or fuse can be traced to the product being tested or the circuit breaker (or fuse) by checking the product’s current draw. If the amperage reading is less

than the breaker reading, the breaker or fuse box is at fault.

### Grounding & Polarity

The receptacle used for all Maytag products operating on 120 VAC must be properly grounded and polarized.

The power cord used on the appliances is equipped with a three (3) prong polarized grounding plug for protection against shock hazard and should be plugged directly into a properly grounded and polarized receptacle.

**Do not cut or remove the grounding prong from this plug.**

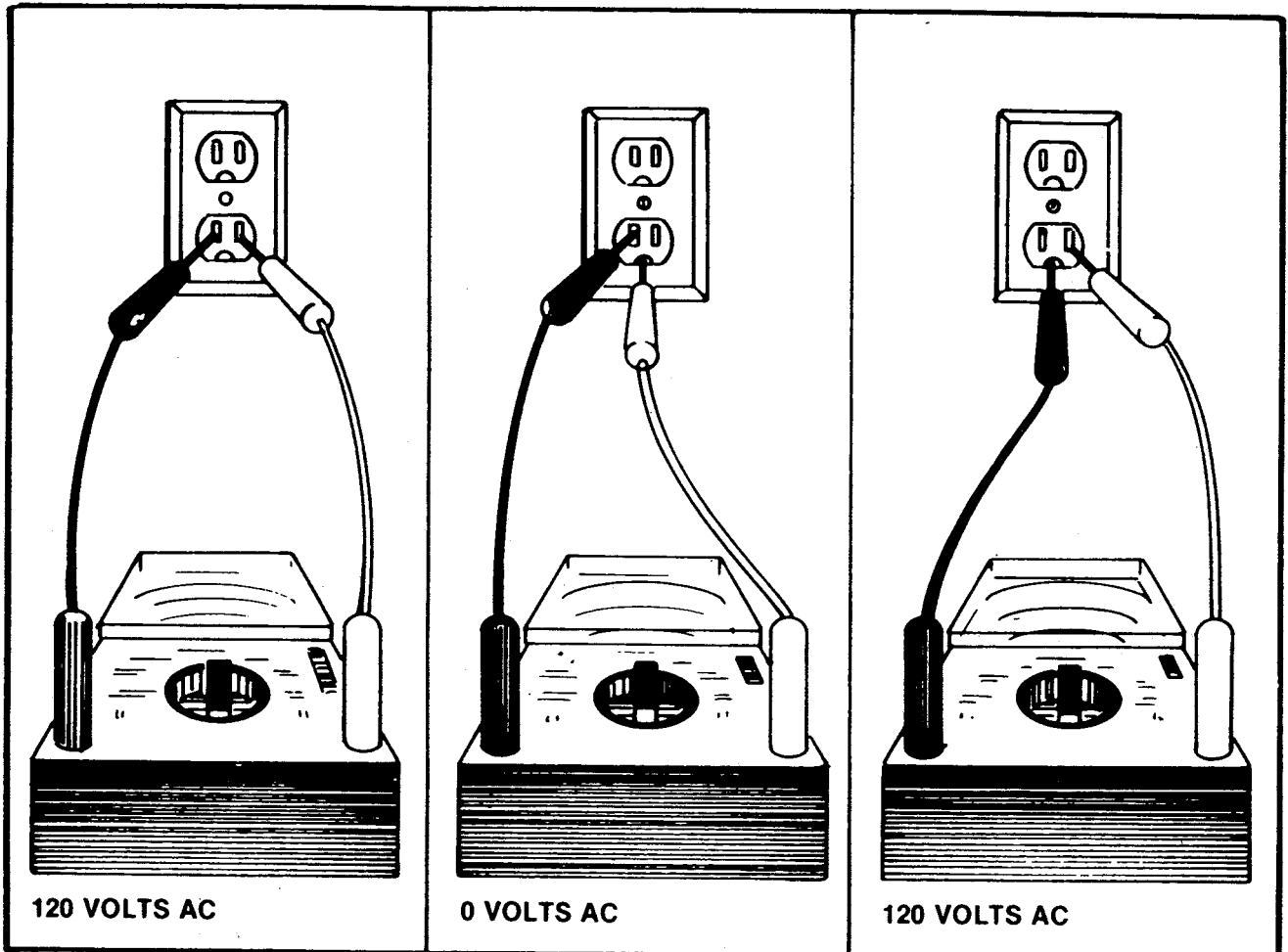

**WARNING:** For your safety and to protect the test equipment, be sure that the wall outlet is properly polarized and grounded (check local codes).

## Motor Test Cord

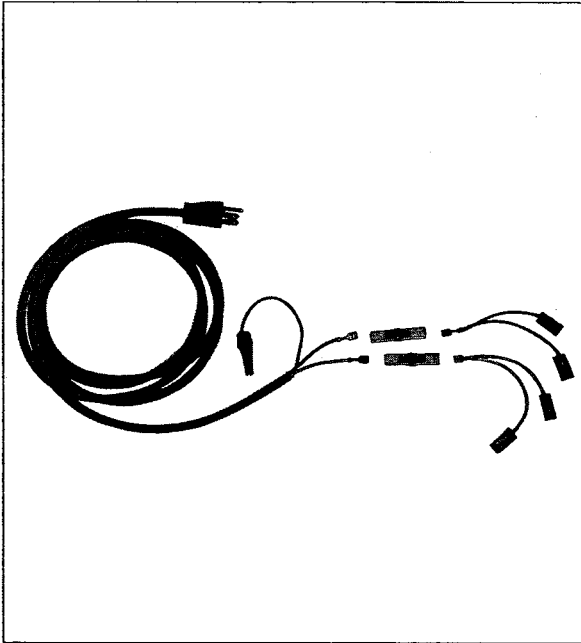

A motor test cord may be used to electrically check operation of the various electrical components without removing them from the unit. Testing in this manner merely determines whether or not the part will function independently of other electrical components. In order

to make accurate tests, proper connection of the motor test cord is important. With the aid of the drawings under Drive Motor Test; installation of the motor test cord may be done quickly and accurately.

### NOTE

Always attach plug test cord to motor before plugging into a grounded receptacle.

### DRIVE MOTOR TEST - WASHER

The motor may be checked in the washer or removed and checked on the bench.

### 2-1805 Single Speed - Reversible - Drive Motor

All four leads of the test cord are required to test the washer drive motor. The following drawing shows installation of the test cord on washer drive motor, (agitate cycle). Reversing the motor to spin is accomplished by reversing wires B and C.

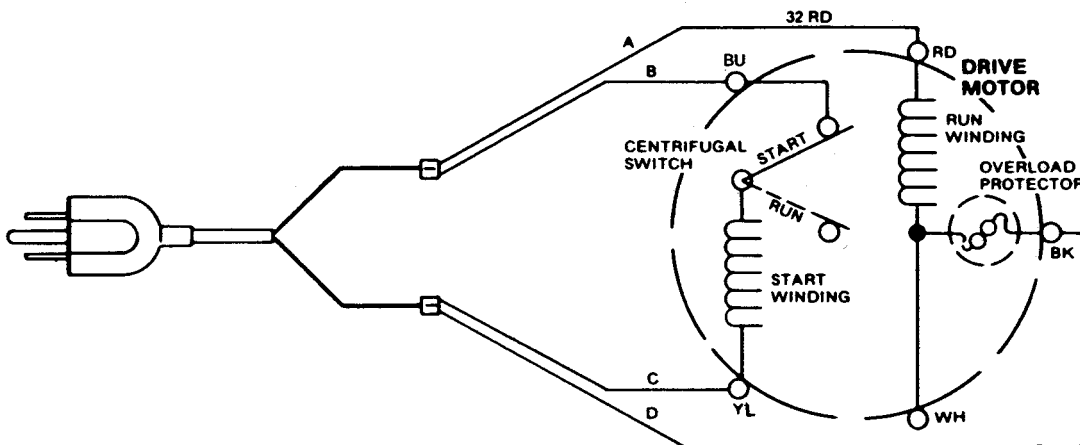

## SECTION 2. SERVICE PROCEDURES

- Manual (MN)
- Coin Slide (CS)
- Data Acquisition (DA)
- Computer Trac II (PD)

The controls section of the washer operates the fill components to bring water into the washer and the motor components to run the drive motor in a clockwise direction (agitate) or counter-clockwise direction (spin). Sequencing of the various parts of each cycle is controlled by an electro-mechanical timer or microprocessor control board and relays.

### CONTROL CONSOLE

The control console is secured to the control housing by means of tamper resistant torx head screws located at the top ends of the aluminum control panel. **Before servicing a washer be sure it is disconnected from electrical power.** You will need part number 038227 torx bit to remove these screws.

Remove the two top end screws and carefully lay the control panel forward. Use a protective cloth to minimize the chance of scratching the panel on the control console.

### MN (Manual) Models

The timer is located at the right end of the control panel. It is secured to the panel by two screws. To gain access to the timer mounting screws, the timer knob and dial must be removed first.

1. **Disconnect electrical power to washer.**
2. Carefully pry the timer knob center cap out of the knob.

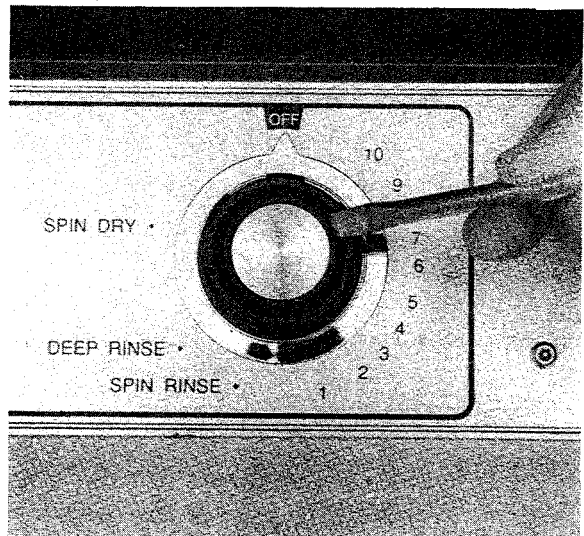

3. Slip the retainer clip off of the timer shaft.



4. Pull the knob, spring and dial off of the timer shaft.

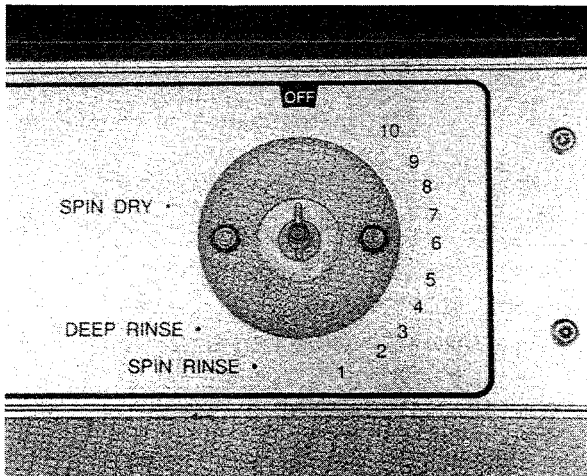

The only replaceable part of the plug-in timer is the timer drive motor.

### CS (Coin Slide) Models

The timer is mounted in the meter case at the top right side of washer. A key will be required to open the timer access door.

The timer mounting bracket is secured by one screw at the top front of the bracket and by tabs at the back of the bracket to the meter case.



**Make sure electrical power is disconnected to washer.** Remove the single screw at the front of the bracket and lift the timer and bracket up and forward to remove from the meter case.

### DA (Data Acquisition) Models

The timer is located at the left end of the control panel and is secured by two screws. To gain access to these screws, the aluminum control panel is removed. **Make sure electrical power is disconnected to washer.** Remove the two screws at the bottom corners of the aluminum panel to remove it.

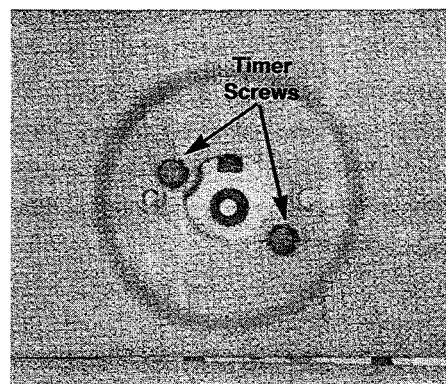

The timer screws will then be exposed.

# TIMER

## NOTICE

**DO NOT ADVANCE THE TIMER WITH THE POWER ON! CONTACT DAMAGE WILL RESULT!**

A Mallory quick connect plug in timer is used in the CS, MN, and DA models. The MN model uses a pull-on, push-off line switch in the timer.

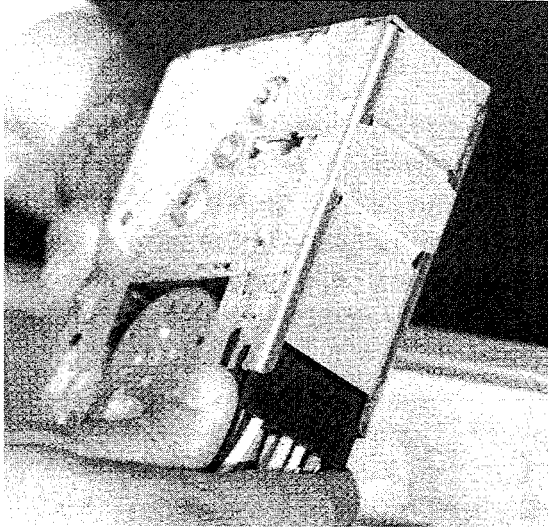

With the timer connection terminals facing you and the timer shaft up, connections for the even numbered cams will be on the left (cams 0, 2, 4, 6, 8, and 10).

The odd numbered cams will be on the right (1, 3, 5, 7, 9, and 11).

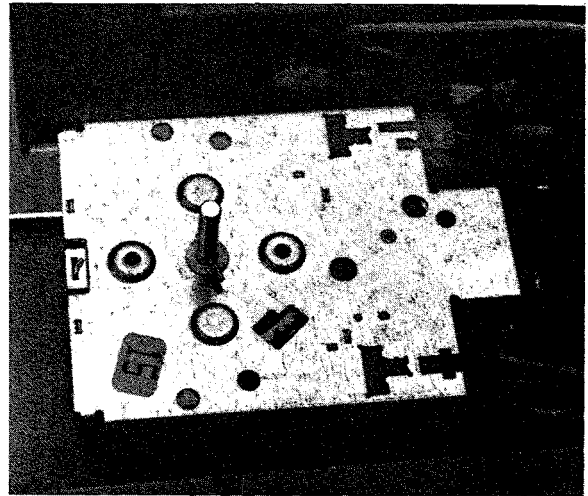

The connectors for the timer will be black for left block and white for the right block. The following drawing shows the connectors from the back or wiring side of the connectors.

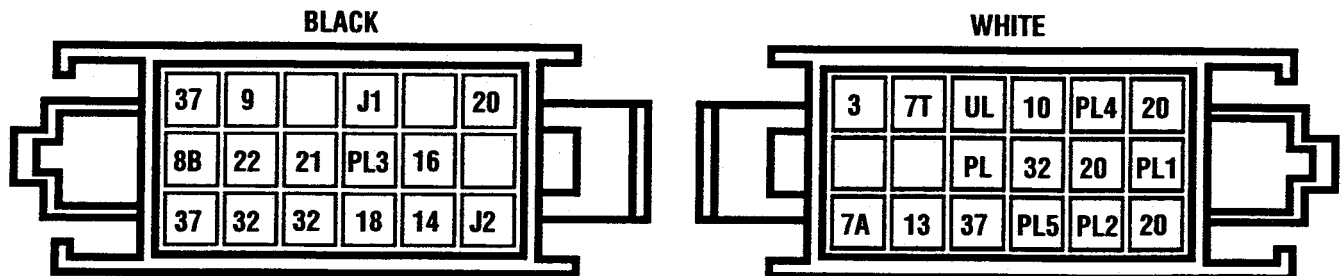

The timer motor is connected between PL3 at the black connector to PL of the white connector.

## Timer Off Position Indicator

A mark on the cam disk will be visible through the window in the timer front plate when the timer is in the "off" position.

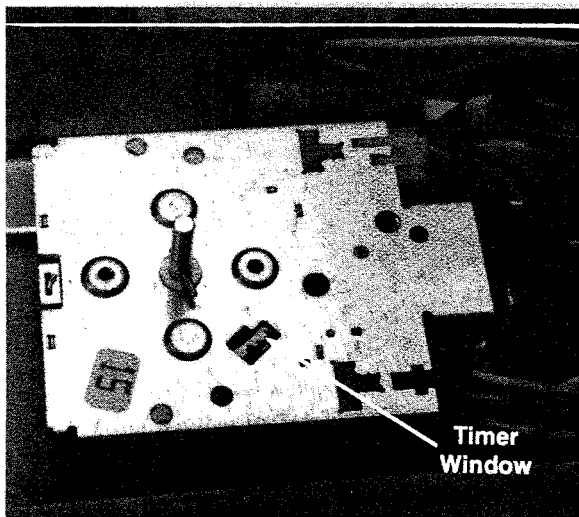

## Rinse Time Selection

The rinse agitation time as set from the factory is one minute. **Disconnect electrical power to washer before servicing.** By moving wires J1 and J2 from the cycle selector switch terminal 20 to terminal 14, the rinse agitation time will be extended to three minutes.

## PD (MICROPROCESSOR/DATA ACQUISITION) MODELS

The microprocessor control board is located at the right end of the control panel, and is secured by four nuts. **Disconnect electrical power to washer before servicing.** To gain access, the two top screws that hold the aluminum panel must be removed. Tip the console forward to expose the control board.

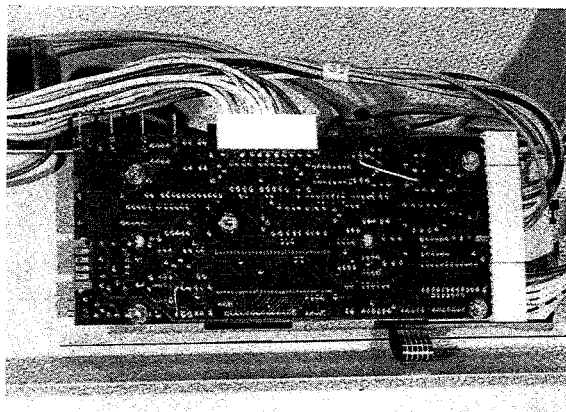

## MICROPROCESSOR

All fill and run operations are controlled by a microprocessor control board and low voltage relays. Inputs from the lid switch and the water level switch work in conjunction with a membrane "touch pad" selector switch to select and start cycles.

Observe the position of the harness connectors plugged into the microprocessor board. There are contact strips on only the back side of the control board. If you place the connector on backwards, the washer will not work and the display will be blank.

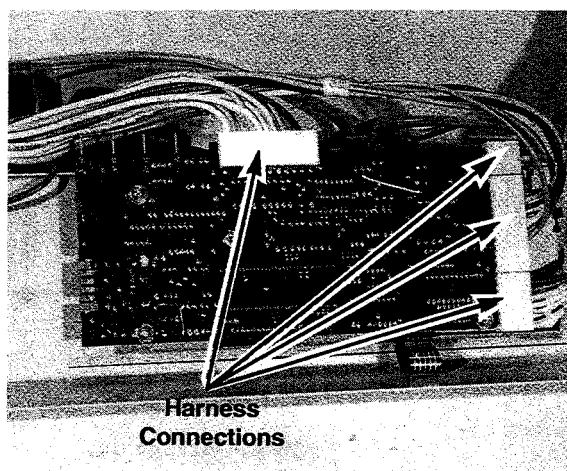

**To avoid damage to microprocessor when removing, disconnect all harness connects from board.**



### To Remove Board:

1. Disconnect electrical power to washer before servicing.
2. Remove four 5/16" nuts from back-up plate mounting studs.
3. Lift board from studs and tilt forward. *Don't lose the spacers.*
4. Disconnect touch pad ribbon. Grasp touch pad "tail" between thumbs and forefinger, ribbon can be pulled out of receptacle.

### Touch Pad Assembly

The touch pad may be checked with an ohmmeter according to the following:

Whites	1 to 3
Colors	1 to 2
Bright Colors	1 to 4
Permanent Press	5 to 3
Wool	5 to 2
Delicates & Knits	5 to 4

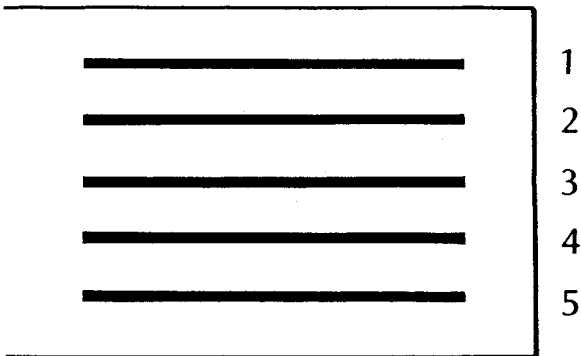

Touch Pad Tail Ink Side Up

### REPLACEMENT

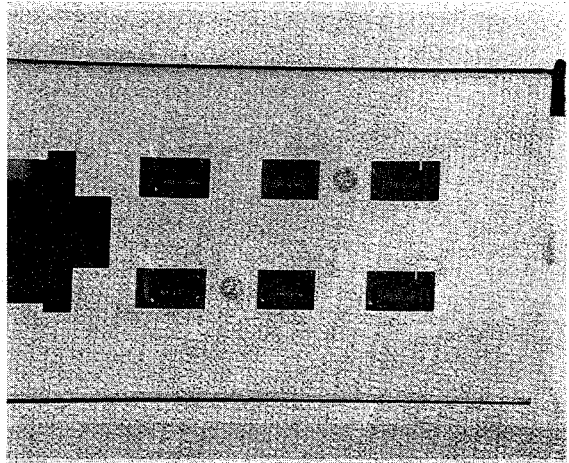

With microprocessor board removed and ribbon disconnected from the microprocessor board, the touch pad can be removed by removing two pozi drive screws from control panel.

**Note:** When replacing the touch pad, secure it first to the control panel. Make sure ribbon connector is properly inserted into microprocessor receptacle before installing microprocessor.

Spacer sleeves are used on studs to aid in proper installation of microprocessor.

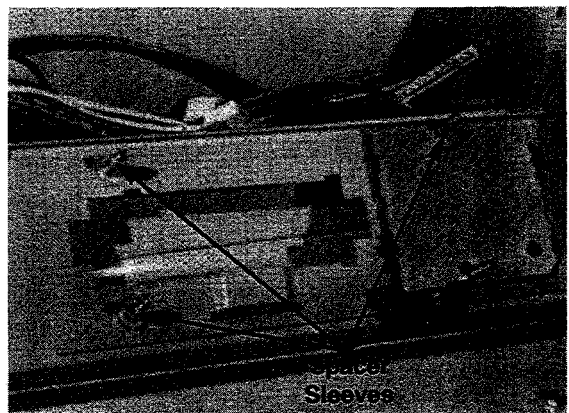

## CYCLE SELECTOR SWITCH

The cycle selector switch is used to select one of six "laundry procedures" for optimum handling of fabrics.

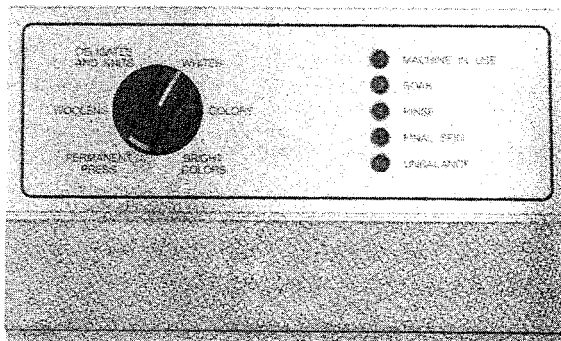

In conjunction with the timer, the selector switch will vary the water temperature and wash cycle sequence. The selector switch is a "package" of six contact sets. The following chart shows the position of the contacts for each of the six selections.

SELECTOR SWITCH						
	White	Colors	Bright Colors	Perm Press	Delicates & Knits	Wool
7A to 6	Closed	Closed	Open	Closed	Closed	Open
7T to 3	Open	Closed	Closed	Closed	Closed	Closed
13 to 3	Open	Open	Open	Closed	Open	Open
13 to 16	Closed	Closed	Closed	Open	Closed	Closed
10 to 20	Closed	Closed	Closed	Open	Closed	Closed
18 to 14	Closed	Closed	Closed	Closed	Open	Open

### To Remove Selector Switch:

1. Disconnect electrical power to washer before servicing.
2. Remove control panel screws (4).
3. Pull selector switch knob off switch shaft.
4. Remove two screws holding switch to control panel.

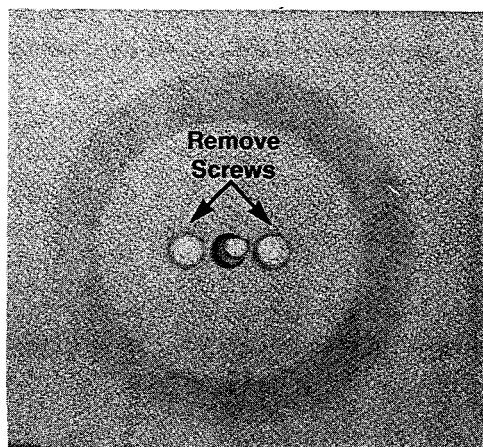

5. Lay control panel forward.
6. Remove wires from switch (note switch position) and remove switch.

\* See *rinse time selection in timer section.*

## CONTROL TRANSFORMER

### DA(Data Acquisition) PD (Computer Trac II)

The low voltage step-down transformer used to power the microprocessor control in the data acquisition and Computer Trac II models is located at the left end of the control housing.

### **DA Models**

The step down transformer has one 24 volt AC secondary (small, lower terminals).

### **PD Models**

The step-down transformer has three secondary windings.

A: 3.8 VAC, center tapped, small terminals on same side of transformer as line voltage input for primary -

White-orange to white-orange 3.8 VAC  
White-orange to blue 1.6 VAC

B: 21.5 VAC, top small terminals, yellow to yellow.

C: 23.8 VAC, lower small terminals, pink to pink.

Voltage readings may vary but should be within 10%. Above readings were taken with a Maycor digital meter at 120.0 VAC on the primary (Brown to Red/Black) side (large terminal).

Transformers in both models feature a fast acting metal oxide varistor surge suppressor connected across the primary. Both transformers use an internal one-shot fuse in the primary in case of excessive current draw on the secondary side.

---

## **VARISTOR (MOV-METAL OXIDE VARISTOR)**

The varistor is designed to protect the microprocessor board from excessive voltage. At normal line voltage, the varistor shows extremely high resist-

ance. When the line voltage exceeds the threshold of the varistor, its resistance decreases to a point of providing a voltage bleed-off path. This will prevent line voltage surges or "spikes" from reaching the microprocessor board.

The varistor is actually part of the transformer. If visual inspection shows a damaged varistor, the transformer should be replaced.

---

## **MOTOR RUN RELAY**

The motor run relay is the one with the black casing and mounted along with the motor reversing relay on the control panel. It is a single throw type and when energized completes the line-one feed from the lid switch to the motor. Both the lid switch and the motor run relay must be closed for power to reach the motor.

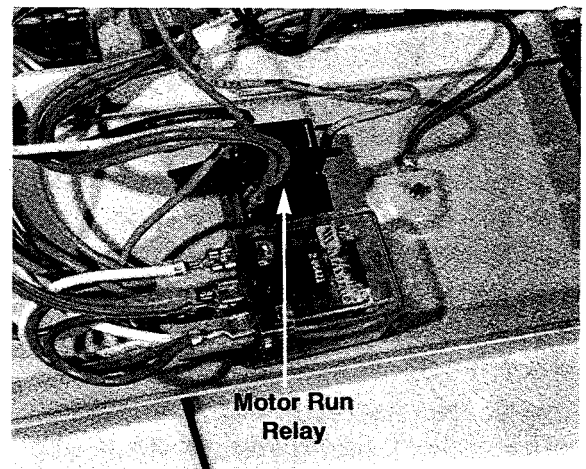

**Note:** The relay has a tab which fits through a slot in a flange that is mounted to the control panel.

## **TEST PROCEDURE**

The relay coil is energized by 24 VDC (volts direct current) which is fed from

the microprocessor board. Once the relay coil is energized, the relay switch will close, completing the circuit.

Because of the low resistance readings found on the relay coil, a continuity check across the coil terminals with an ohmmeter is recommended. A closed circuit (continuity) should be seen. If an open circuit (no continuity) is seen, the relay should be replaced.

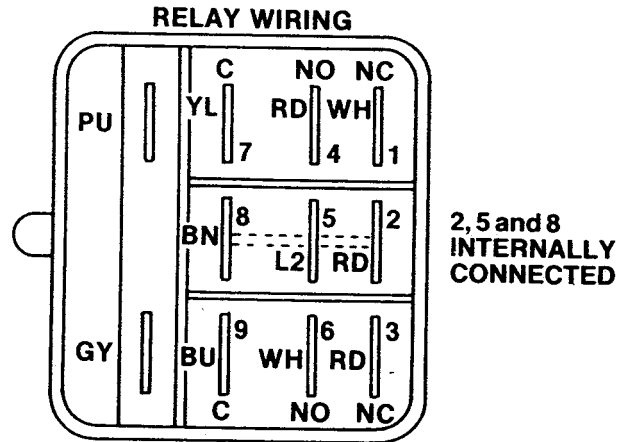

## MOTOR REVERSING RELAY

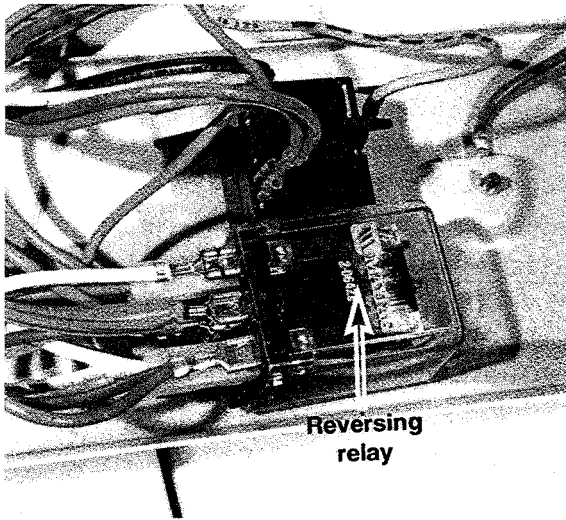

The motor reversing relay is also known as the "spin" relay. This relay is a double pole, double throw type switch. When not energized, this relay is wired to run the motor for agitation.

When energized, the relay contacts reverse the start-winding connections to the motor (blue to yellow wires) and causes it to start and run for spin.

If the washer fails to spin, check the reversing relay.

AGITATE	SPIN
1-7	7-4
3-9	9-6

### To Remove:

1. Disconnect electrical power to washer before servicing.
2. Remove all wires from relay.
3. Remove screw securing relay and spring clip to flange. Note positioning tab for ease in mounting and locating relay and spring clip.

## TEST PROCEDURES

*To test reversing relay, disconnect electrical power to washer.*

1. Unplug purple and gray wires from relay coil.
2. Measure resistance of relay coil. Resistance should show approximately 350 ohms.

An infinite reading indicates an open coil and requires relay replacement.

3. Reinstall coil wires (purple and gray).

### CAUTION:

*The following is a live voltage check. Use appropriate care.*

- Place washer in diagnostic mode and stop in agitate mode (when "A" appears in display).

When in agitate, voltage from yellow to red should be 115 volts and voltage from blue to red should be 0 volts.

- Advance machine into the spin portion of the diagnostic mode and hold it there (when "S" appears in display).

When in spin, voltage from yellow to red should be 0 volts and voltage from blue to red should be 115 volts.

	AGITATE	SPIN
YL-RD	115 VAC	0 VAC
BLU-RD	0 VAC	115 VAC

If these voltages did not change from agitate to spin with machine still in the spin portion of the diagnostic program, check for 24 VDC (direct current) across the purple and gray wires of the coil. If 24 VDC is present, replace the relay. If no 24 VDC is present, check micro-processor board or wiring.

If voltages changed but machine agitates when it was suppose to be spinning and vise versa, check to see that yellow and blue wires are connected to proper terminals on both relay and motor.

---

## INDICATOR LIGHTS

The indicator lights are one complete assembly. If one light burns out, replace the assembly.

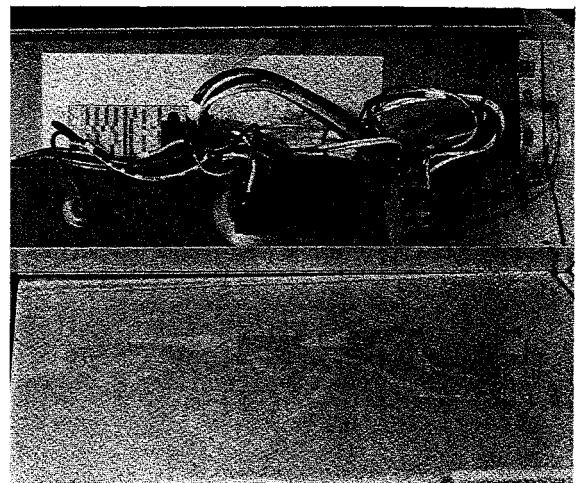

To Remove Indicator Lights:

- Disconnect electrical power to washer before servicing.
- Remove screws holding control panel and lay panel forward.
- Compress retainer clips and remove assembly from back side of control panel.
- Remove wires from assembly.

---

## LID SWITCH ASSEMBLY

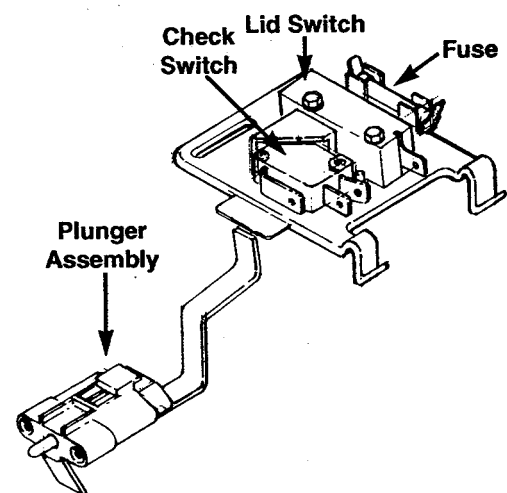

The lid switch assembly consists of a lid switch and (depending on model) a check switch and (depending on model) a 1 amp fuse.

## MN and CS Models

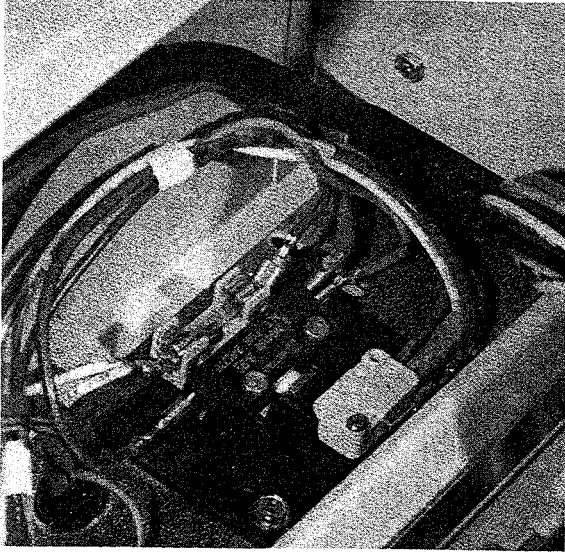

The lid switch assembly consists of a lid switch (single pole, single throw), a check switch (single pole, double throw) and a 1 amp fuse mounted on an insulated plate. The end of the lid switch/unbalance lever actuates the lid and check switches.

### Lid Closed

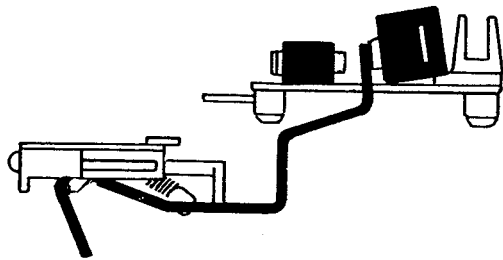

**LID CLOSED**

The lid switch/unbalance lever will push the actuator button of the lid switch in moving it from the normally open position to the closed position. Electrical power from the line will be passed through the closed switch con-

tacts to the common terminal of the double throw check switch.

With the lid closed the actuator button of the check switch will not be in contact with the lid switch/unbalance lever. The check switch will be in its normal position with the common made to the normally closed contact (UL-12 made to M-8B). Power from line 1 is therefore connected to timer terminal 8B (input to timer).

### Opening The Lid

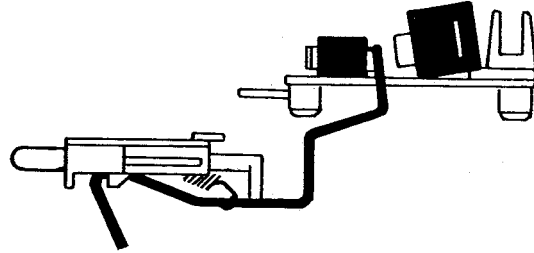

**LID OPEN**

As the lid of the washer is raised, the lid switch/unbalance lever releases the button of the lid switch opening the contacts. Power to the check switch common is interrupted.

As the lid is further raised the lid switch/unbalance lever will contact and actuate the button of the check switch. Even though the check switch contacts will physically be moved, no electrical action will take place because the lid switch will have previously broken the circuit.

When the lid is closed the lid switch and the check switch are in series with the line power input to the timer. When the

lid is opened, first the lid switch then the check switch will open to interrupt the line power input to the timer.

---

### Lid Switch Failure

If the lid switch should fail in the open position (no contact), the washer will simply be non-operative (dead).

If the lid switch fails in the closed position, the check switch will still break the circuit to the timer as the check switch button is activated by the lid switch/unbalance lever. This will stop the washer. As a method of calling attention to a failed lid switch, a fuse in the washer's fill circuit will be blown. It works this way:

As the check switch button is actuated, it not only opens the power line circuit to timer 8B, it also transfers that line power to line fuse wired in the neutral side of the fill circuit. If the water level control is in the empty position, a circuit is made from the lid switch through the check switch to the fuse from line one. The neutral side of the line is made to the fuse through the pressure switch to the fuse and the fuse opens. The washer is effectively put "out of service" as it will not fill for the next fill operation. The symptom would be that the machine in use lamp would come on but there would be no water entering the washer and no advancing of the timer.

---

### DA (Data Acquisition) Models

A single pole, double throw lid switch is used in the DA models.

When the lid is opened the lid switch

common transfers from UL to 8B move to UL to SW. This transfer must take place or the microprocessor control will not start the next cycle (reset operation). A stuck lid switch would allow completion of the cycle in process but would not start a subsequent cycle. In addition, the "add coins" indicator lamp would remain out.

---

### PD (Microprocessor/Data Acquisition) Computer Trac II Models

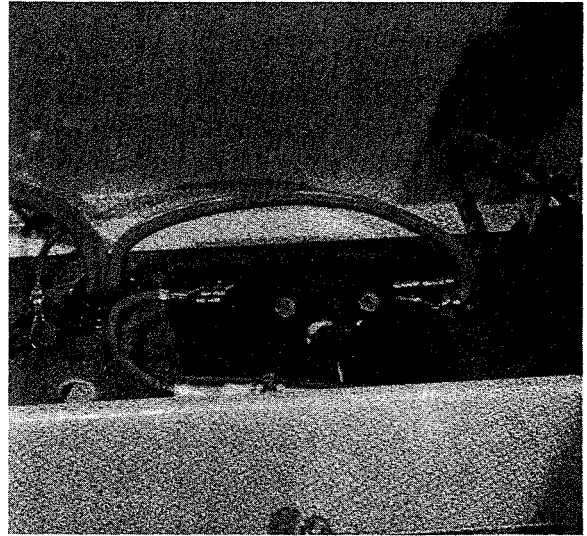

A single pole single throw lid switch is used. The lid switch circuit must open or the microprocessor will not reset for the next cycle. The display would remain showing "0 minutes remaining".

---

### WATER LEVEL PRESSURE SWITCH

The amount of water allowed into the washer is controlled by an air pressure operated water level control located in the control housing. The water level switch is secured to the washer top cover, (just left of center) by two screws.

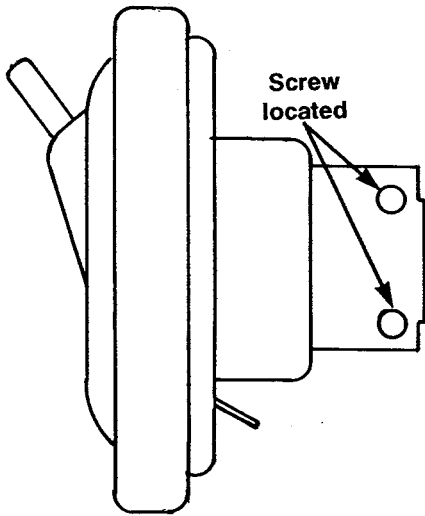

A rubber "air dome" hose connects between the pressure switch and the bottom of the outer water container (tub).



During the fills, air trapped in the air dome hose is squeezed by the rising water level up into the water level switch diaphragm chamber. At a preset point, the increasing air pressure against the diaphragm will cause the switch to toggle from fill (empty position) to run (full position). This will shut the water flow off and energize the motor run circuits.

### SERVICE PROCEDURES

If the switch is functioning erratically, the washer tub should be emptied of

any water and then remove the air tube from the control switch. If this procedure is not followed, any water trapped in either the air dome or upper air tube can cause the switch to be falsely actuated and start the water agitating before the proper water level has been reached.

If it is found that the water is trapped in either of these areas, check the mechanism for air leaks. As stated, water normally in the air dome will be drained from it as the water is emptied. However, if any water is drawn into the air tube, this water cannot be removed by merely spinning the washer, and it will be necessary to check for air leaks. This would be particularly true when installing a new switch. Therefore, when a new switch is installed, blow out the air tube from the control switch end.

No attempts should be made to adjust the water level control. The switch has been factory calibrated for a proper balance of conditions which MUST be maintained to assure proper operation of the water level control. Field adjustment is NOT recommended.

### ELECTRICAL TESTING

With the switch removed, it may be tested using an appliance test meter by placing leads on terminals indicated in the following chart. The switch should be tested for "Fill" and "Run".

SETTINGS	CHECK TERMINALS
Empty (Fill)	20-15 closed circuit 20-16 open circuit
Full* (Run)	20-15 open circuit 20-16 closed circuit



If meter does not indicate a closed or open circuit as shown in the chart, replace switch.

\*Set control to "Full" position for testing by gently blowing into orifice of control until "click" is heard. Quickly place finger over end of orifice and make electrical check.

---

## Water Level Adjustment

The water level control as shipped is set to provide adequate water in the washer to prevent wear on the clothes. The water level is factory set to be at or just above the top row of perforations (holes) in the wash basket.

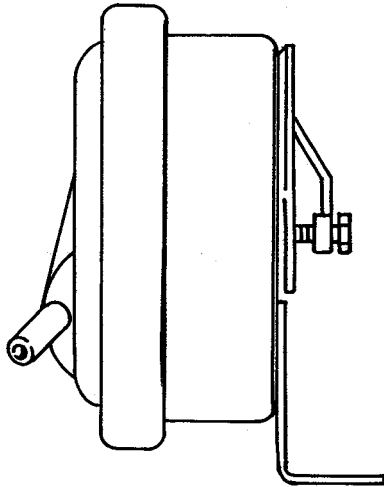

A provision has been made to drop this water level and reduce the total water consumption per cycle by moving a tab on the pressure switch bracket. Move the plastic shim toward the mounting bracket to allow the button of the pressure switch to pop up through the cut out in the shim.

**Note:** On large loads, this may not provide enough water for free movement at the load during agitate. It will

save water but may increase wear on the clothes and on the washer.

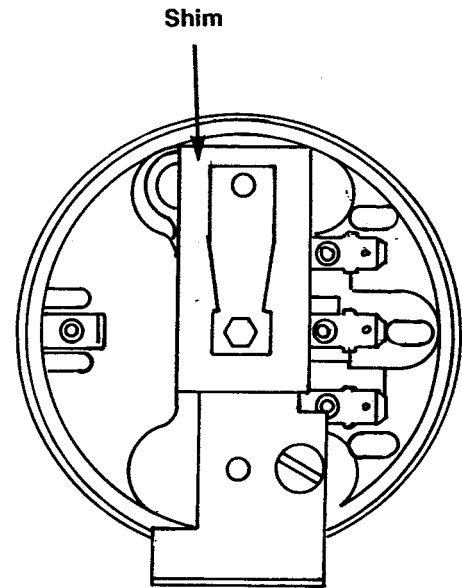

---

## AIR TUBE AND DOME

A single piece air tube and air dome is used on all models. The air tube end is connected to the spout on the water level switch. The air dome end is connected to a spout on the outer tub.

### To remove the air tube and air dome:

1. **Disconnect electrical power to washer before servicing.**
2. Remove air dome access plate (on back of washer).
3. Remove two screws and lay control panel forward.
4. Remove air tube from water level control.
5. Remove clamp securing air dome to tub nozzle.
6. Remove air tube from clamp which holds tube to back panel. Pull air tube out of top cover.
7. Remove air tube and dome through air dome access.

---

## WATER VALVE

If the washer won't fill properly, make the following checks before replacing the water valve.

- **Disconnect electrical power to washer before servicing.**
- Check faucets to make sure they are turned on.
- Check screens in inlet hoses at faucets and at inlet of water valve. Be sure they are not plugged.
- Check water level control. Be sure the air dome tube is attached to the the control and the tub. For electrical checks, see Electrical Troubleshooting Section.
- Check water valve coils for continuity. The Maycor appliance test meter scale is marked open and closed to indicate continuity or an incomplete circuit. If there is an incomplete circuit, there is either a bad coil or a wiring problem. If a coil is bad, the water valve should be replaced.

### To Remove Water Valve:

1. **Disconnect electrical power to washer before servicing.**
2. Remove screw holding valve bracket to back panel.
3. Pivot out until flange clears back and lift up to disengage the bracket from the slot on the back panel.
4. Disconnect wires.
5. Remove two screws holding water valve to mounting bracket.

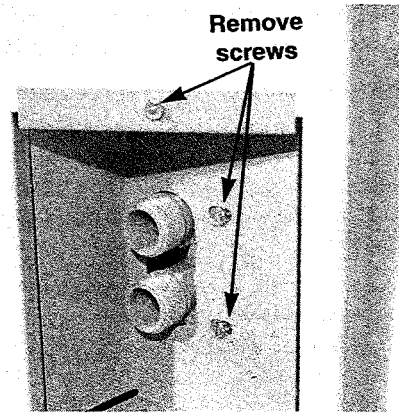

6. Remove injector hose.

**Note:** This is a non-repairable valve.

---

## WATER INJECTOR ASSEMBLY

The injector housing is connected to the top cover. A hose is connected to the injector housing from the water valve.

### To Remove Injector Housing:

1. **Disconnect electrical power to washer before servicing.**
2. Remove two top screws securing aluminum panel and lay control panel forward.
3. Remove cover securing injector housing to top cover. After screw has been removed, secure control panel to console.

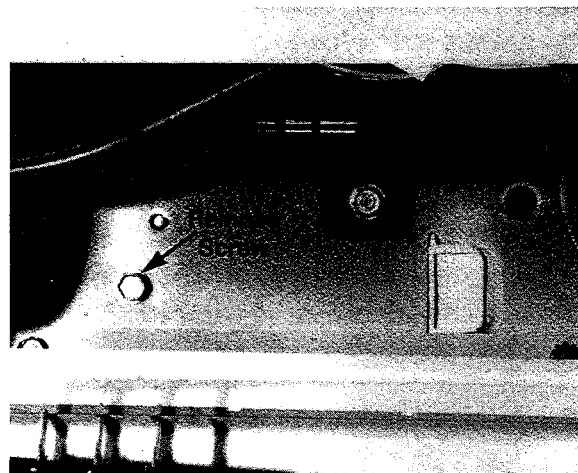

4. Remove two screws, securing front panel.
5. Remove two screws securing top cover to cabinet. Secure the lid to the top cover and tilt backwards.
6. There is a tab on the injector housing under the flange of the top cover. Remove injector housing by sliding assembly to the left.

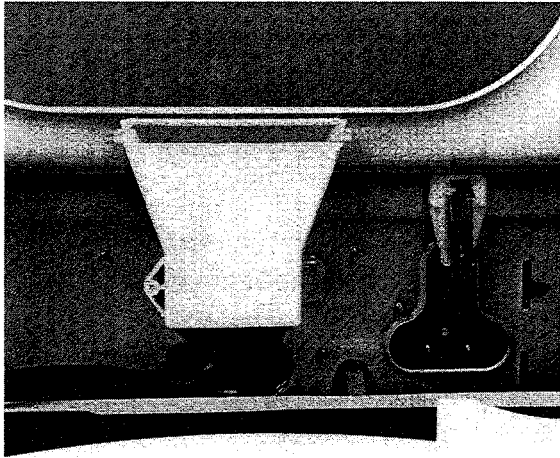

7. Remove clamp from hose attached to the injector housing.

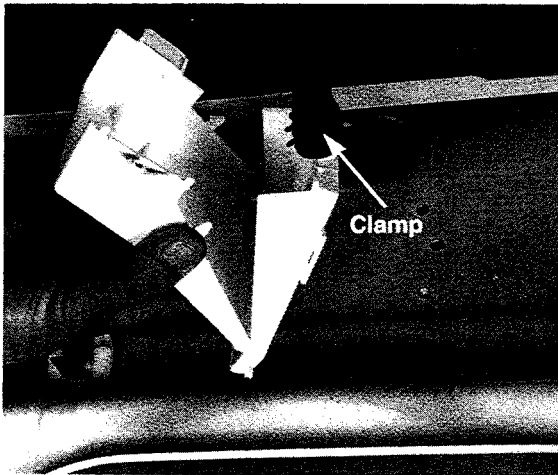

8. Reverse procedures to assembly.

---

## METER CASE

The meter case houses the coin box and depending on the washer model a coin slide or coin drop assembly. The meter case is secured to the washer top by a twin-bolt mounting strap which ties the top and meter case together. **Disconnect electrical power to washer before servicing.** Two 5/16-18 hex nuts and lock washers thread on to the mounting strap studs inside the meter case. The coin box must be removed for access to the front hold-down stud and the meter case access door must also be removed to gain access to the rear nut and stud. This will require a 9/16" socket. Screws from inside console housing, securing the meter case to the console will need to be removed before meter case can be removed.

---

## COIN SLIDE

**Disconnect electrical power to washer before servicing.** The Maytag coin slide washer is not shipped with a coin slide. Your local distributor will assist you in choosing one with the features you require. The coin slide is secured to the meter case front by four shoulder screws on the slide itself and by a locking bolt tightened from inside the meter case. Maytag coin slide models are shipped with a locking bolt with 1/4" x 20 male threads which will fit the more popular coin slides available. Be sure you have the correct locking bolt threads for the coin slides you are using.

**To remove a coin slide for cleaning or servicing:**

Unlock and remove the meter case access door. Loosen the locking bolt from inside the meter case front to clear the shoulder screws and pull the slide out of the meter case.

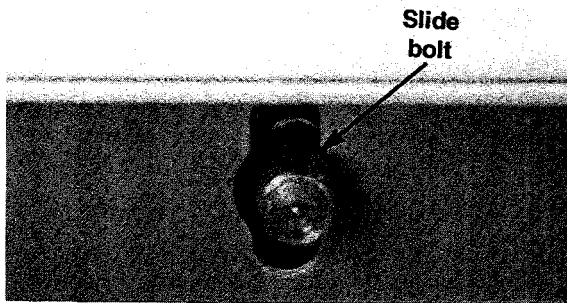

Most coin slides are cleaned in hot water and allowed to air dry. Lubrication is not recommended as oil tends to attract lint.

**Timer Actuator Adjustment for Coin Slide:**

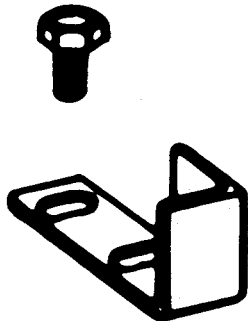

The bolt-on timer actuator must be adjusted for the particular coin slide so that a coin slide excursion will advance the timer into the cycle. The mounting holes in the actuator provided with the washer are slotted to allow proper adjustment.

**COIN DROP ACCEPTOR**

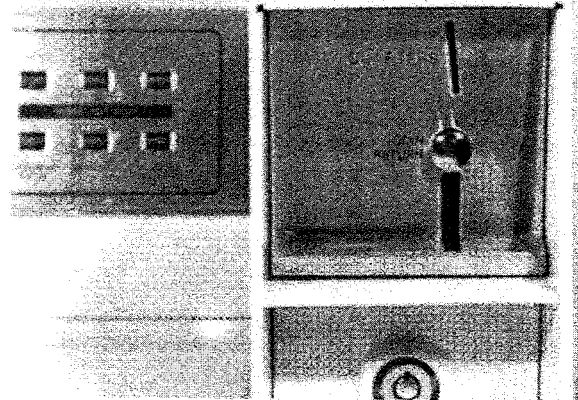

Both the DA (Data Acquisition) and PD (Computer Trac II) models use a mechanical coin drop assembly. In normal use, occasional cleaning in hot water will be all that is needed to maintain reliable operation.

The coin drop assembly checks coins for diameter, thickness and magnetic properties.

**Diameter:**

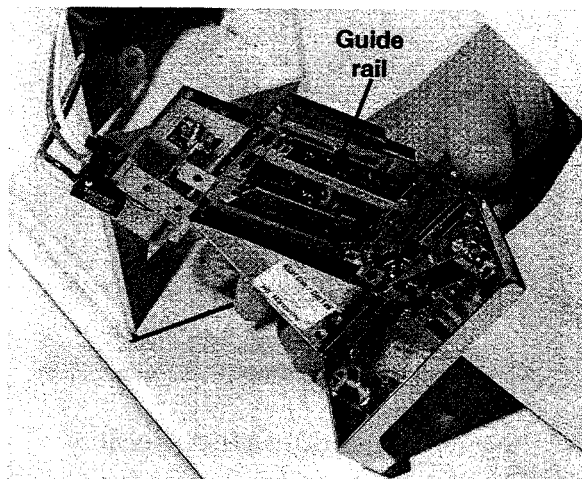

A guide rail on the left plate of the coin drop assembly is adjustable (both at the front and rear) to accept proper diam-

eter coin. yet reject oversized coins. Adjust the front pin in the guide rail to just miss the quarter and tighten the front guide rail screw. Set the back guide rail pin to also just allow the quarter by and tighten the back guide rail screen.

#### Thickness:

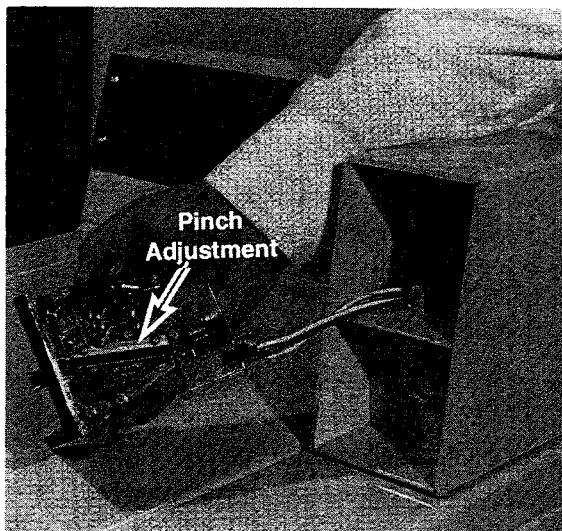

A "pinch" adjustment allows the coin drop assembly to check coins for thickness. The adjustment is located on the right side of the coin drop assembly. Loosen the small "jam-nut" which locks the adjustment screw. Turning the screw clockwise opens the adjustment and accepts thicker (or slightly bent) coins. Hold the adjustment screw and retighten the jam-nut after adjustment.

#### Rear Chute:

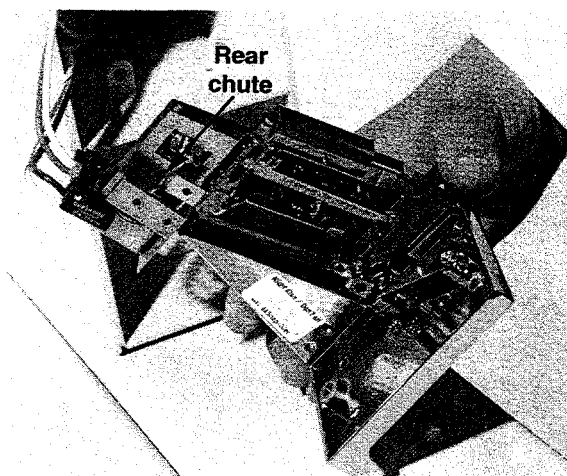

A "penny window" is located on the left side of the rear chute assembly. Two deflector scoops are used to direct undersized coins out this half-circle opening. If the scoops are in too tight, some good coins could hang up at this point. If you observe that, just bend the scoops open a little to correct the problem.

#### COIN SENSOR

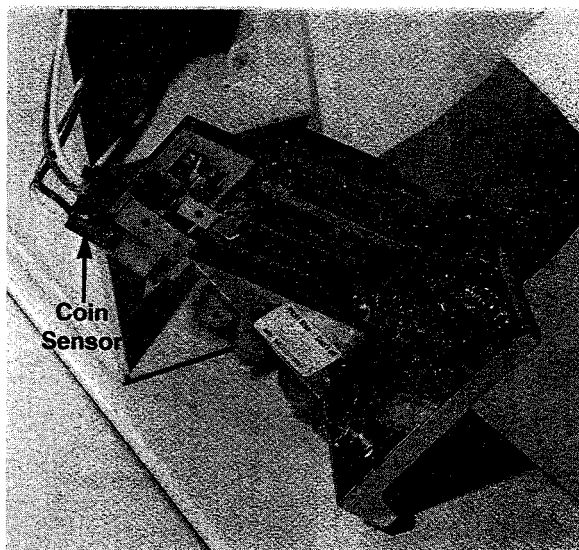

The coin sensor assembly combines a light emitting diode infrared light source aligned in a yoke with a light sensitive photo-transistor. In the normal, standby condition, the infrared light beam from the L.E.D. keeps the photo transistor in conduction (on). Voltage at the collector lead of the photo transistor (red) will be rather low, less than one volt DC as measured to common (white lead). When the light beam is interrupted (coin drops through) the photo-transistor turns off causing a positive pulse to be generated on the control board.

## SERVICE DOOR & COIN VAULT MONITOR SWITCHES

### Important

The monitor switch wiring must not be shorted to the cabinet. Unplug the washer before servicing the switches.

1. Unlock and open the service access door. The Add Coins light will blink when the door is opened.

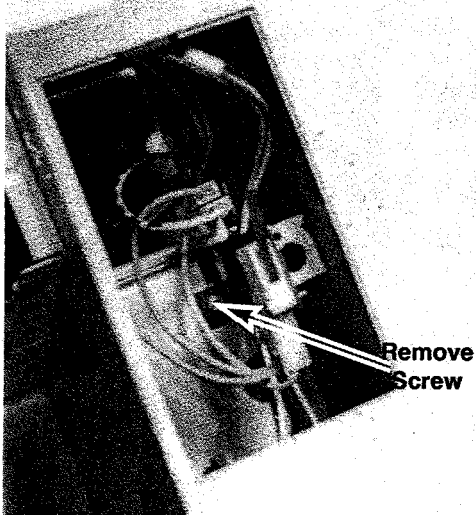

2. With the washer unplugged, remove the 1/4" hex-head screw securing the switch mounting bracket and lift the switches from the meter case.

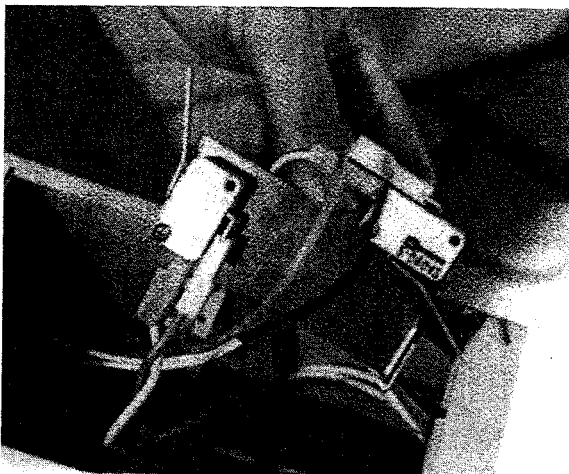

When replacing the switch assembly in the meter case, be sure the coin vault switch leaf is positioned behind the coin box if the coin box has not been removed. Failure to position the switch leaf correctly will prevent removal of the coin box.

## LID

### To Remove the Lid:

1. Disconnect electrical power to washer before servicing.
2. Raise the lid where it is at a 45° angle with the top cover.
3. With the left hand, grasp the left side of the lid toward the back. With the right hand, grasp the right side of the lid at the front right corner.
4. Taking care to watch the right hinge ball, pull towards you with the right hand. When the lid is disengaged from the right side of the top cover, catch the right hinge ball, remove the lid and catch the left hinge ball.



### To Replace the Lid:

1. Place a hinge ball in the recess of the left side of the top cover. Holding it in position, place the lid over the ball so the ball is in the recess on the left side of the lid.

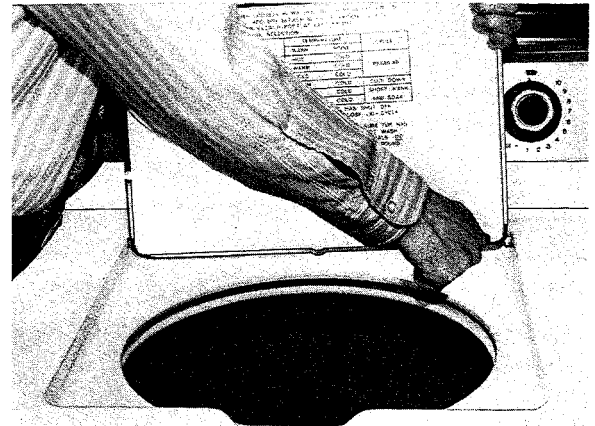

**Note:** If the fit between the right hinge ball and the lid is so tight you cannot press it into position with the right thumb, carefully strike the right corner of the lid with the palm of the hand to snap it into position.

2. Hold the lid with the left hand as shown in the following photo keeping sufficient pressure against the left side to insure the hinge ball will remain wedged between the lid and the top cover.
3. With the right hand, place a hinge ball in the right side of the top cover recess.
4. Push the lid down against the hinge ball on the right side and with the right thumb. Press down sharply to engage the lid with the hinge ball on the right side.

---

## TOP COVER

1. **Disconnect electrical power to washer before servicing.**
2. Remove two screws holding front panel. Pull front panel up and away from bottom.
3. Remove two top cover bolts and tilt the top cover back. Hold lid closed or tape lid to top cover to prevent it from striking the control panel.

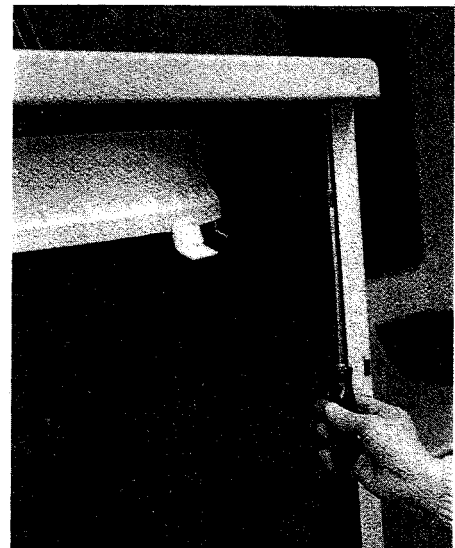

## TUB COVER

The tub cover is secured to the outer tub with eight (8) tabs. To the rear of the tub cover you will see the flange, sticking upwards. This is what trips the unbalance lever on the lid switch. The tub cover can be removed by pushing downward on the tub cover and pulling tabs out and away from outer tub.

### To Remove Tub Cover:

1. **Disconnect electrical power to washer before servicing.**
2. Secure lid to the top cover.
3. Remove two screws securing front panel.

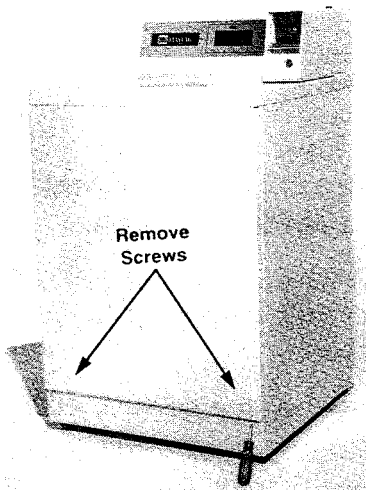

4. Remove two screws securing top cover to cabinet, and tilt top cover backwards.

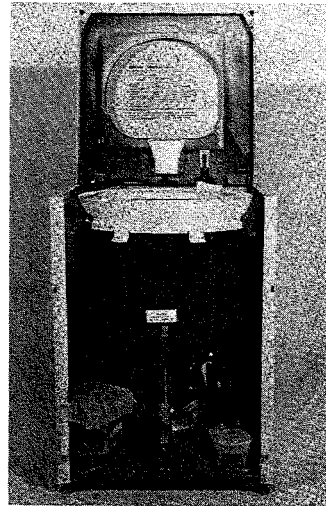

5. Remove tub cover by unsnapping the tabs, securing tub cover to outer tub.

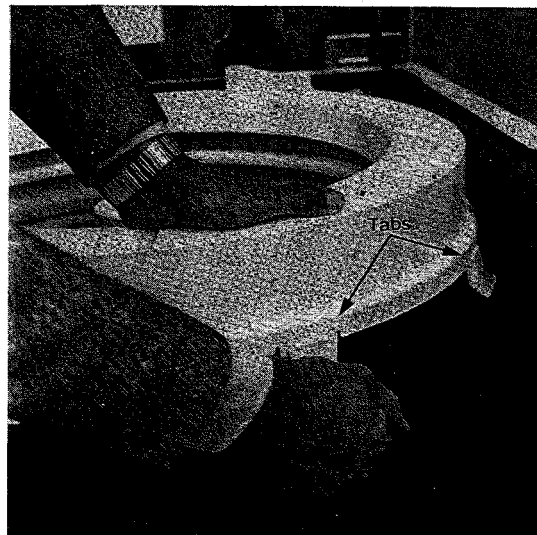

6. Reverse procedure for assembly.

## BALANCE RING

**Disconnect electrical power to washer before servicing.** The balance ring is connected to the inner tub by three (3) tabs.



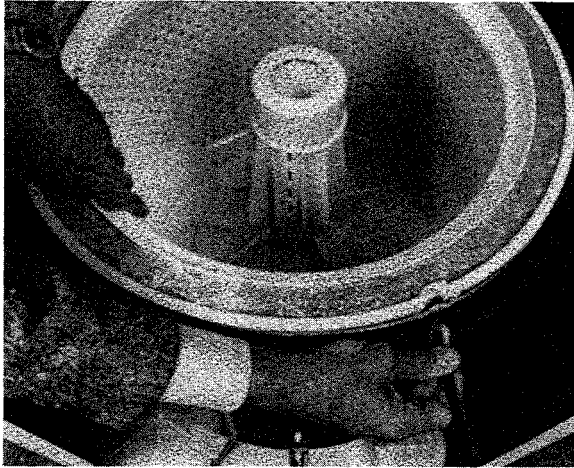

You can remove the balance ring by inserting a pencil or other small pin through the three small holes in the outer tub depressing the tabs on the balance ring. Try using a thin piece of cardboard to place between the tab and outer tub once you have inserted the pencil through the hole to depress the tabs. This will allow you to work on the other tabs for easy removal.

---

## AGITATOR

The agitator is secured to the agitator drive shaft with a 1/4" hex head screw in the barrel of the agitator into the groove of the agitator shaft.

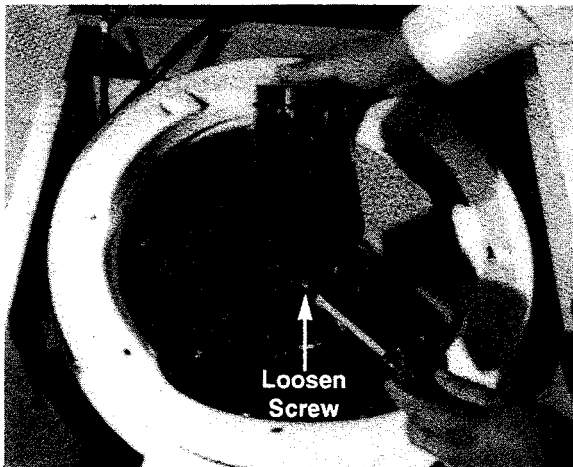

Before attempting to pull agitator, loosen the screw.

When replacing agitator, be sure to push down until agitator is bottomed before retightening the screw.

---

## ACCESS PLUGS

Two solid plugs in the bottom of the inner tub will be used in CS, DA, MN, and PD models.

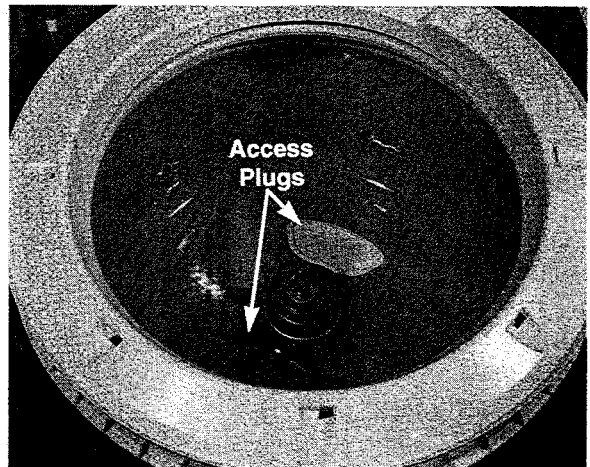

### To Remove Access Plugs:

1. Loosen screw located on the side of the agitator.
2. Remove agitator.
3. Pry out plug. It is held in place with several tabs. Grasp plug in the center on the long side. Lift up and push in at the same time to remove plug.
4. Replace plug by pressing into place.

---

## CENTER SHAFT SEAL

This is a water seal that prevents water from getting into the transmission.

### To remove seal:

1. Remove agitator. Back screw located on the side of the agitator out far enough to pull agitator off the agitator shaft.
2. Pry out lock ring for retaining washer.
3. Remove retaining washer.

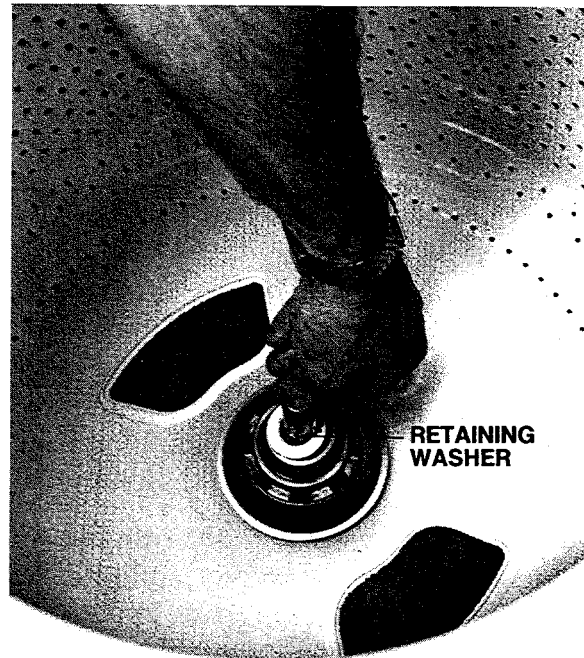
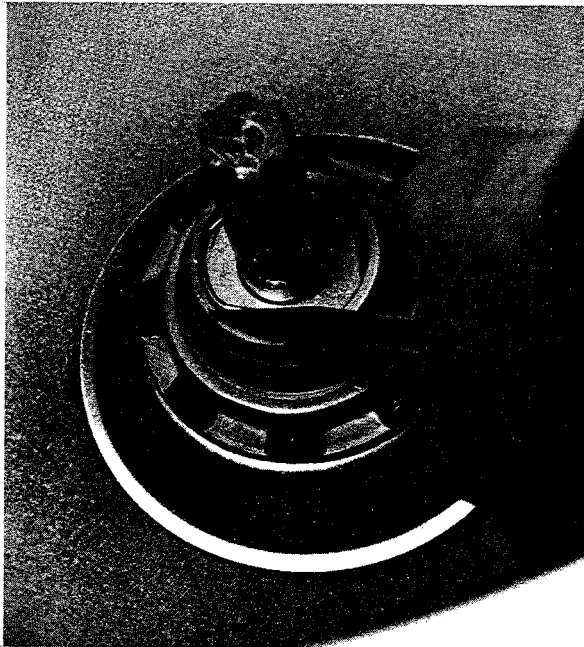

4. Remove Seal by prying out.

**Note:** When replacing this seal, the outside should be dry and the inside should be lubricated with center seal grease (56016). Small end of the seal must go against agitator shaft collar.

---

## INNER TUB

### To remove inner tub:

1. Disconnect electrical power to washer before servicing.
2. Remove front panel.
3. Raise top cover.
4. Unsnap tub cover from outer tabs and remove tub cover.

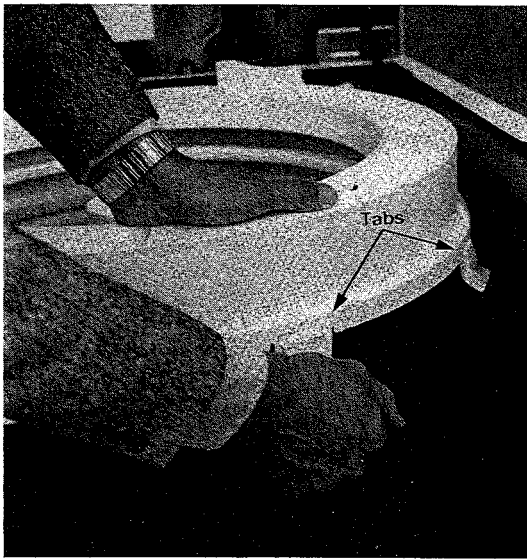

5. Remove agitator.
6. Use spanner wrench (038313) to remove clamping nut. This is a left-hand thread so it must be turned clockwise. A mallet will be required to loosen the nut. Use care when striking wrench to prevent chipping the tub.

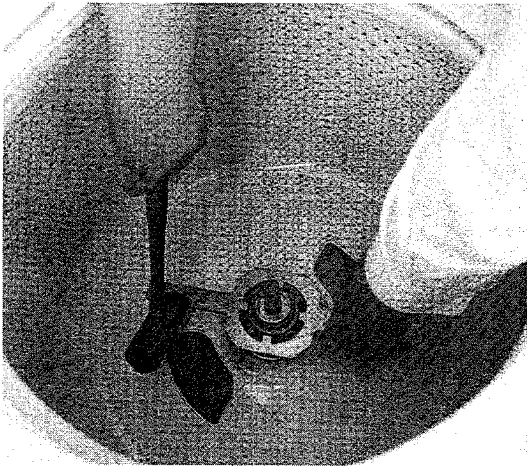

7. Remove clamping nut washer.

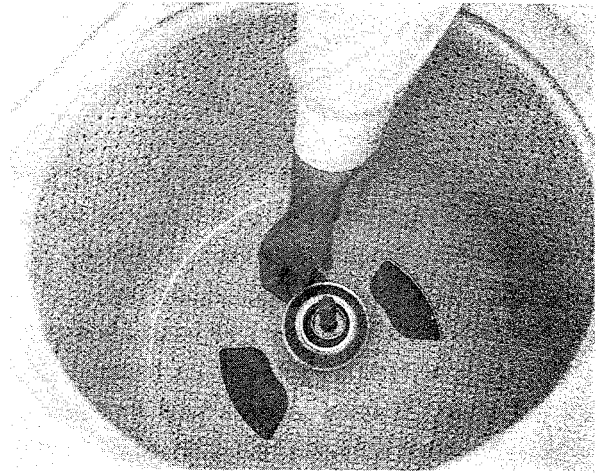

### Replacing tub:

1. When replacing the inner tub, rock it back and forth on the mounting stem to make sure it is seated properly.
2. Replace washer and nut.
3. Tighten nut. Use care not to chip tub.

---

### Tube Centering

If it should be necessary to recenter the tub, use the following procedure:

1. Place a 1/2 lb. weight in the tub.
2. Allow the washer to reach full spin speed.
3. When the washer reaches full spin speed, turn off power to the washer and allow the tub to come to a complete stop before opening the lid. The opening in the tub cover should be centered with the opening in the top cover, but with a small portion of the tub cover visible at the back. This visible portion of the tub cover should not exceed 1/4".
4. If the proper amount of the tub cover is not visible at the back or the tub is off center on either side, tighten the opposite damper spring and recheck as outlined above.

## MOUNTING STEM AND BOOT SEAL

If a water leak occurs it can be detected by removing the front panel and using a flashlight to inspect the tub bearing. If the boot seal is leaking, water will come out through the openings around the tub bearing holder. A "telltale" symptom of such a leak is water around the inside of the cabinet at the level of the transmission. As water leaks out of the bearing area it will generally pick up some oil. If this is a leak, use the mounting stem repair kit.

### To Replace Mounting Stem and Boot Seal:

1. **Disconnect electrical power to washer before servicing.**
2. Remove two screws holding front panel. Pull front panel up from bottom and remove.

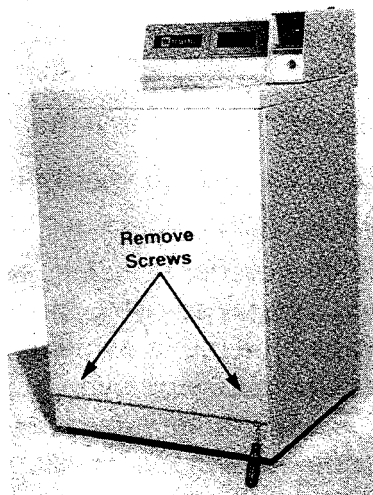

3. Remove two bolts holding top cover and raise top cover.

**Note:** Tape lid so when top cover is laid back the lid won't bang against control cover.

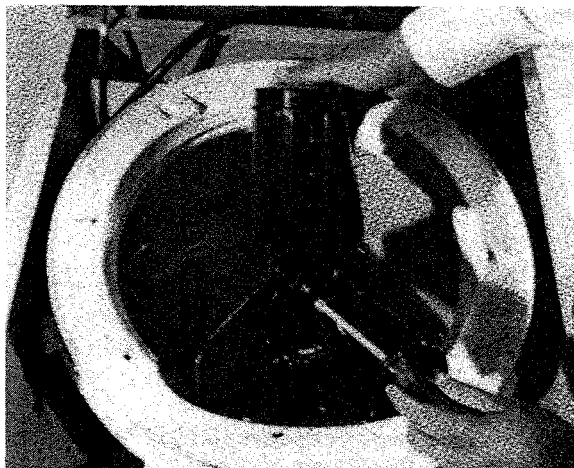

4. Remove agitator.

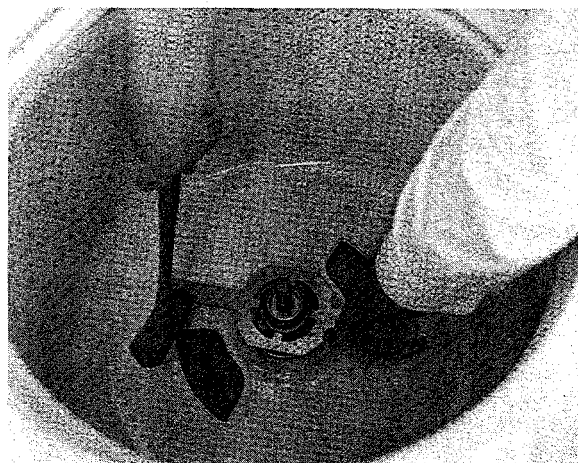

5. Use the Maytag spanner wrench to remove clamping nut. This is a **left-hand thread so it must be turned clockwise**. A mallet will be required to loosen the nut.

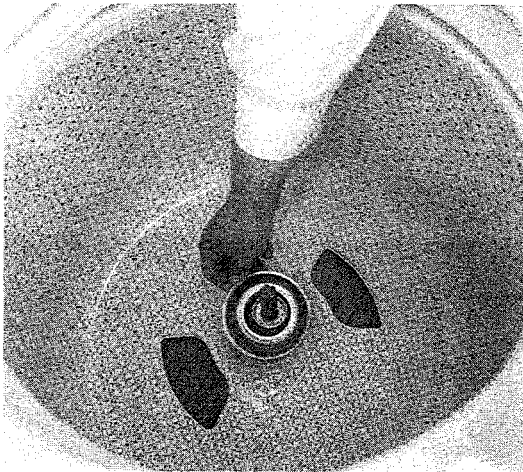

6. Remove the clamping nut washer.
7. Unsnap tub cover and remove tub cover.
8. Remove inner tub.
9. Remove the screw in the mounting stem.

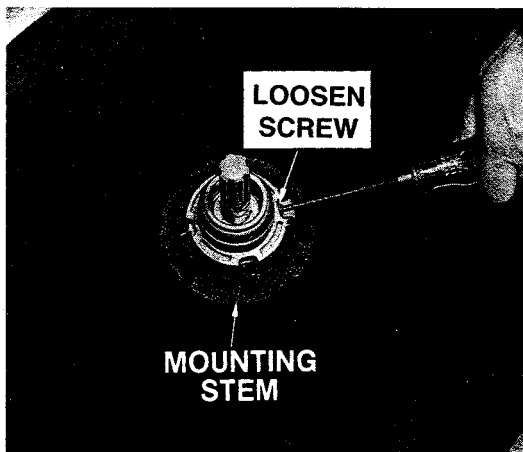

**Note:** When replacing the screw, position wrench as shown in the following photos and tighten screw. With screw securely tightened, the end of the screw will be flush or protrude by 1/6" out of the mounting stem (see following photos). If the screw goes in further than flush it is probably going into the recessed groove. If this happens, back the screw out and tighten the mounting stem some more. Then retighten the

screw. The screw must not be seated in the groove.

10. Use a Maytag spanner wrench to remove mounting stem. Like the clamping nut, this is a **left-hand thread and must be turned clockwise**. A mallet will be required to loosen the mounting stem.
11. When the mounting stem is lifted off you have access to the "O" ring and boot seal.

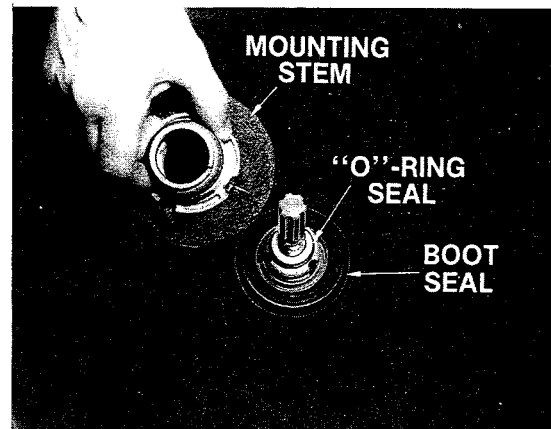

12. The "O" ring may be moved with a thin blade screwdriver or ice pick.
13. **Remove boot seal by twisting clockwise.** Do not grasp around carbon ring.

#### REASSEMBLING THE MOUNTING STEM

- Center seal grease should be used on the mounting stem threads. When the mounting stem has been turned on the center stem and hand-tightened, use the spanner wrench to seat the mounting stem. Tap the spanner wrench several times with a hammer to seat.
- Before inserting the screw into the mounting stem, lubricate the hole in the mounting stem with Maytag grease. Be sure to tighten the screw securely.

**Note:** Screw must not be in a water relief groove.

## OUTER TUB

### To Remove Outer Tub:

1. Disconnect electrical power to washer before servicing.
2. Remove inner tub.
3. Loosen screw in mounting stem.
4. Use a Maytag spanner wrench to remove mounting stem. Like the clamping nut, this is a left-hand thread and must be turned clockwise. A mallet will probably be required to loosen the mounting stem.
5. When the mounting stem is lifted off you have access to the "O" ring and boot seal.
6. The "O" ring may be removed with a thin blade screwdriver or an ice pick.
7. **Remove boot seal by twisting clockwise. Do not grasp around carbon ring.**
8. Loosen clamps and remove drain hose and air dome from outer tub.
9. Remove three bolts that hold the outer tub to the tub braces. To facilitate removal of tub bolts, remove outside nuts, lock and retaining washers and push tub bolts through the tub. Lift off outer tub.

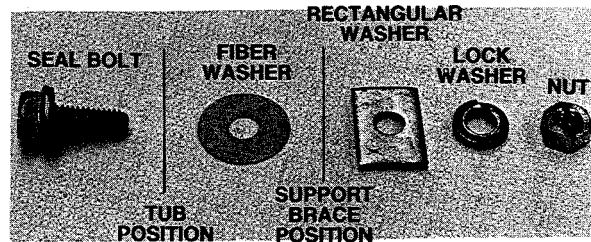

Note: The location of tub and seal bolt, fiber washer, brace, retainer washer, and washer and nut.

10. Remove outer tub.

### REPLACING OUTER TUB

1. When replacing tub bolt nuts, just get them started. Do not tighten them until you have the front bolt also started. Using the brake package tool, you can hook the front brace to apply pressure to move the brace against the tub. This makes it easier to get the lock washer and nut on the front tub bolt.

#### REMEMBER

The two rear bolts are longer than the front bolt. **DO NOT** use a long tub bolt in the front position.

2. Replace pressure switch air dome hose and tub outlet to pump hose.
3. Install mounting stem and tighten in a counterclockwise direction. Observe the location of the set screw hole in relation to the water relief grooves from the top of the stem (before the center seal is installed). The screw must not end up in one of the grooves. Tighten as needed.

4. With the mounting stem properly installed, insert the center seal with the small end down.

Install the stainless steel washer and retainer spring clip.

5. Reinstall the wash basket (inner tub).
6. Position tub cover with trip bracket parallel to back panel. Snap the tabs into place on the outer tub.

---

## TUB BEARING

The tub bearing is a sintered metal bearing molded in rubber to fit with the outer tub. The inner face of the mounting stem tightens down on the bearing sleeve locking it to the power unit. The sleeve always turns with the power unit inside the outer tub bearing in spin.

### To Remove Outer Tub Bearing:

1. **Disconnect electrical power to washer before servicing.**
2. Remove outer tub.
3. Because of the porcelain tub and molded retainer, it is not practical to drive the tub bearing from the tub. To remove the bearing from the tub, elevate the tub so that the porcelain drain tube clears the floor. This could be done by placing a 2x4 or a doubled over corner post under the tub.
4. Apply pressure on the bearing pushing it from the tub. This can be done by standing on the bearing.

### To Replace Tub Bearing:

1. Turn tub over, starting bearing into tub cover.

**Note:** Caution should be exercised to see that the tub bearing is started into the tub straight to prevent and erratic or egg-shaping when seated in the tub.

2. Press bearing into place by applying pressure. This may also be done by standing on the bearing. To avoid getting dirt in the bearing, place a protective cloth over the bearing before standing on it.

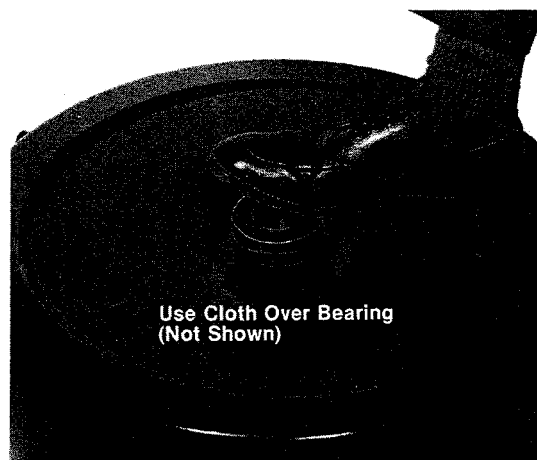

---

## DEPENDABLE DRIVE TRANSMISSION

1. **Disconnect electrical power to washer before servicing.**
2. Loosen the screw in the agitator and remove.

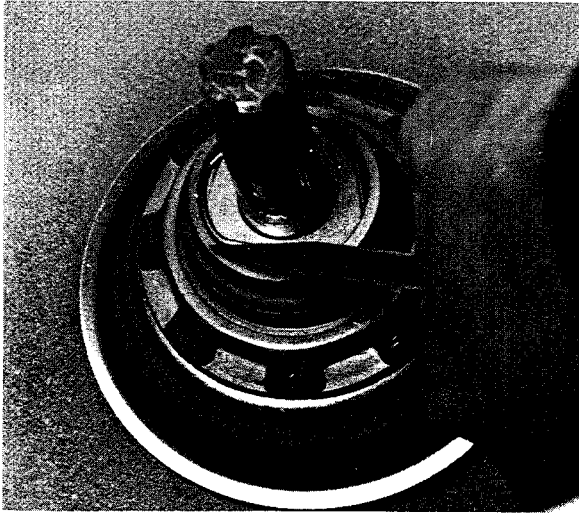

3. Remove the retaining clip for shaft seal. This is located in the top of the mounting stem and is easily removed with a screwdriver.

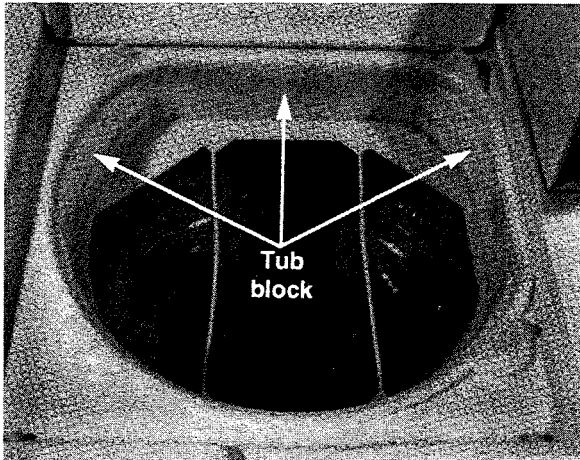

4. Place the tub block in the tub.
5. Remove the front panel.
6. Lay the washer on its back and remove the belts.
7. Place an oil catch pan under the center hub of the transmission. *(Take used oil to your local oil recycling center for proper disposal).* The motor cover will do for this.
8. Remove the eight (8) hex head bolts with a 7/16 nut driver. Be sure the bolt heads are facing up. This will

insure that you will not get oil all over the back of the washer should the cover come loose. Cut around the cover to separate silicon Maytag RTV sealer used as a gasket.

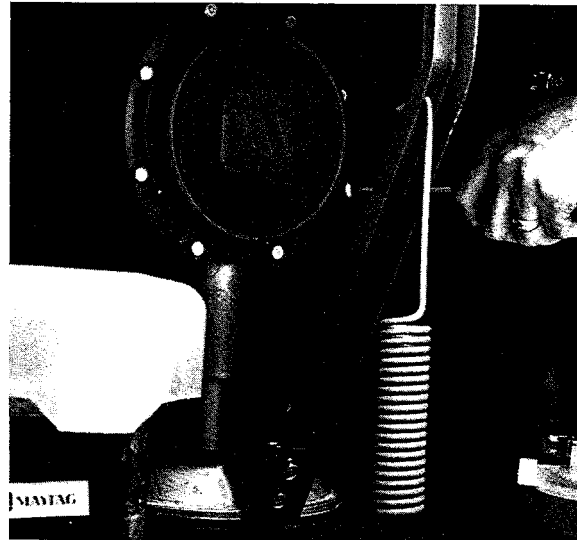

9. Remove the cover plate (it may be necessary to pry the plate off with a screwdriver). Carefully rotate the transmission, dumping the oil into your catch pan.
10. Remove the agitator shaft retaining spring by pulling it out and off the agitator shaft. Care should be taken when removing.

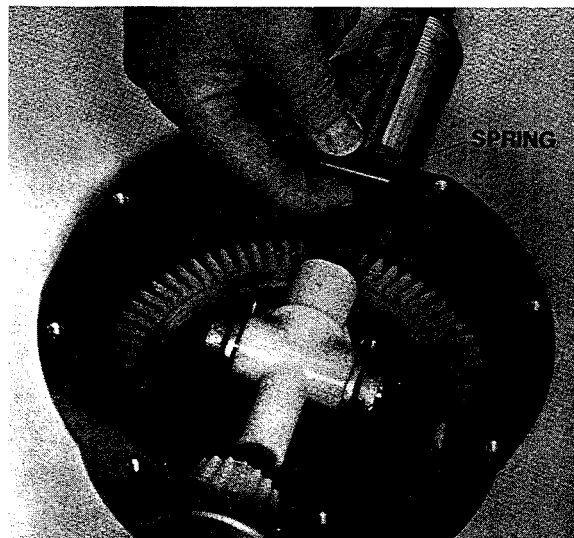

11. Remove the lower collar pin with a 3/16" Allen wrench.



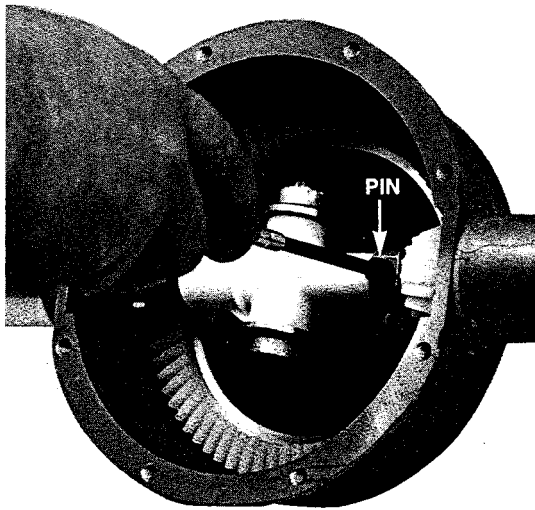

12. Grasp the drive pulley and slowly pull the center shaft out. Only a small amount of force will be needed to remove the shaft. Be careful not to damage the lip seal at the bottom of the transmission.
13. Pull the agitator shaft out through the tub. Remove the "O" ring from shaft.

**Note:** You may have to pull hard on this as the oil in the torque block forms a suction.



14. With the agitator and drive shafts removed, simply lift out the following parts: lower collar and pinion gear, followed by the clutch

plate and splined washer which are both located under the pinion gear.

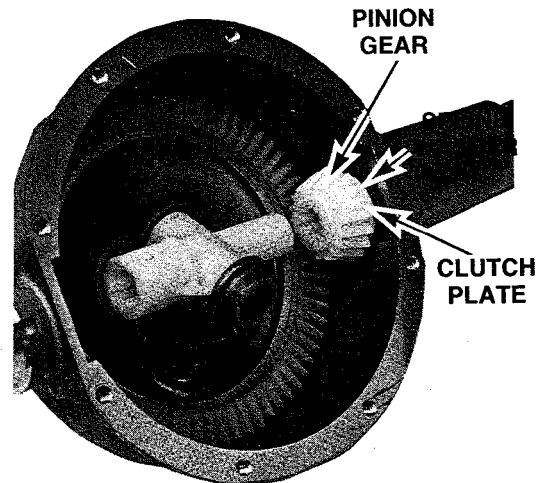

15. The torque block and yoke can now be removed as can the bevel gear. Underneath the bevel gear is a spacer washer. Remove it.

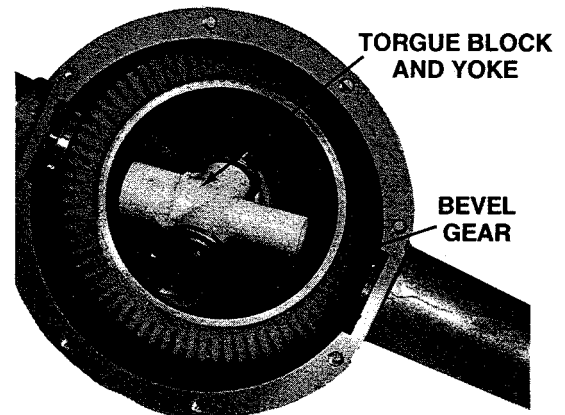

16. At this point, all components to be reassembled should be cleaned. Also, clean any silastic from the transmission housing and cover before reassembling.

## REASSEMBLY

1. Install spacer washer followed by the bevel gear on the center stud pin. Apply thin film of oil on stud before installing gear.

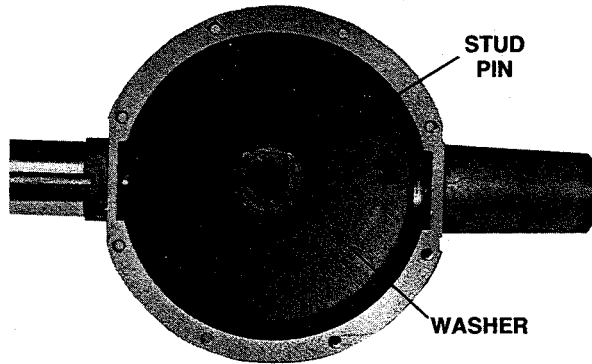

2. Place pivot stud of torque block yoke into the hole in the bevel gear. Point the unsplined portion of the torque block towards the bottom of the washer.

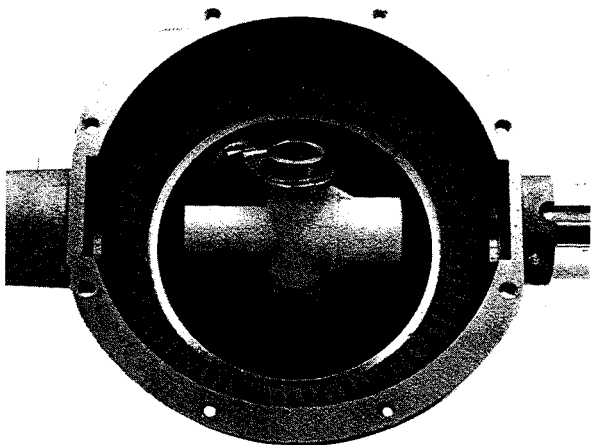

3. Place the copper splined washer on the bottom and clutch plate washer on top, and lay them in the slot as shown.

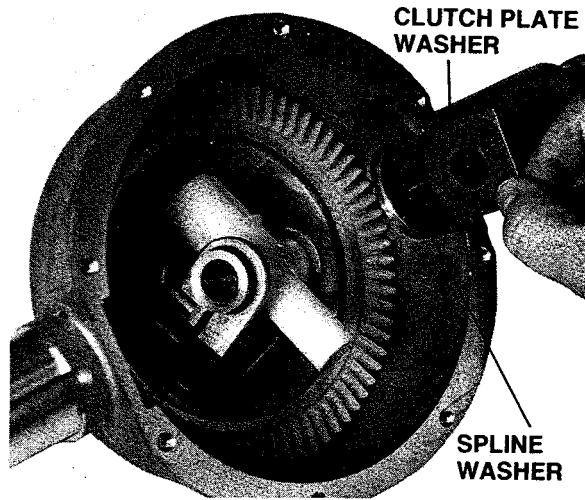

4. Place the pinion in line with the drive shaft hole, then push the drive shaft through the various components until it is flush with the top of the pinion gear. Some minor twisting of the shaft will be required in order to line up all of the splines.
5. Now place the lower lock collar between the unsplined portion of the yoke and pinion gear. Push the shaft into the smaller unsplined portion of the torque block and yoke.
6. With all of the parts of this segment aligned and in place, install the pin for lock collar and tighten. Use thread locking compound on pin threads.

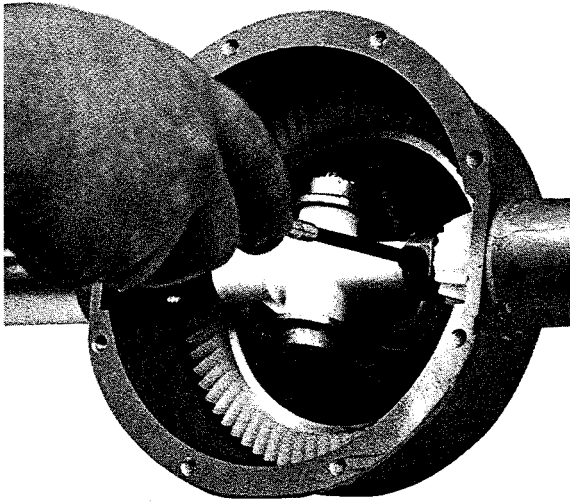

7. Insert the agitator shaft in through the top of the transmission housing. Align the splines and push together.
8. Place the agitator shaft spring into the groove portion of the agitator shaft. Squeezing the spring together will be required before it can be inserted into the groove.

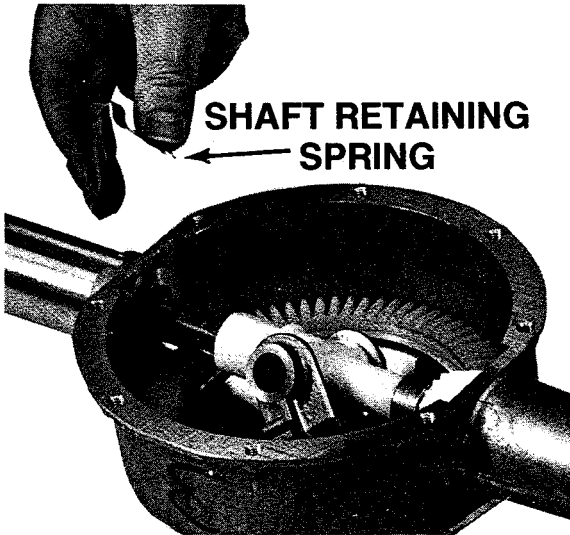

9. Rotate the drive gear (counterclockwise) to check the transmission for proper operation.
10. Apply a new bead of Maytag RTV silastic to the edge of the transmission housing. Fill with Maytag transmission oil. One bottle is a complete fill.

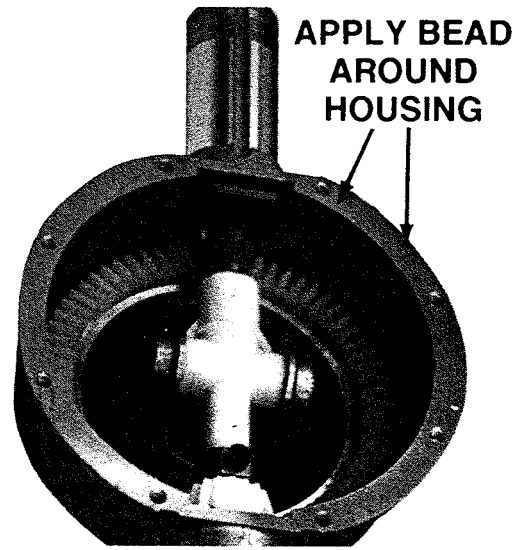

11. Place the cover on the housing. Insert the eight (8) bolts and tighten. Be sure not to over tighten these eight (8) bolts so as to prevent stripping the threads.
12. Reinstall the belts and front panel. Place washer upright and remove the tub block.
13. Insert the "O" ring over the agitator shaft. With the use of the two screwdrivers, work the "O" ring over the collar and back into the "V" groove between the agitator shaft collar and the upper stem bearing.

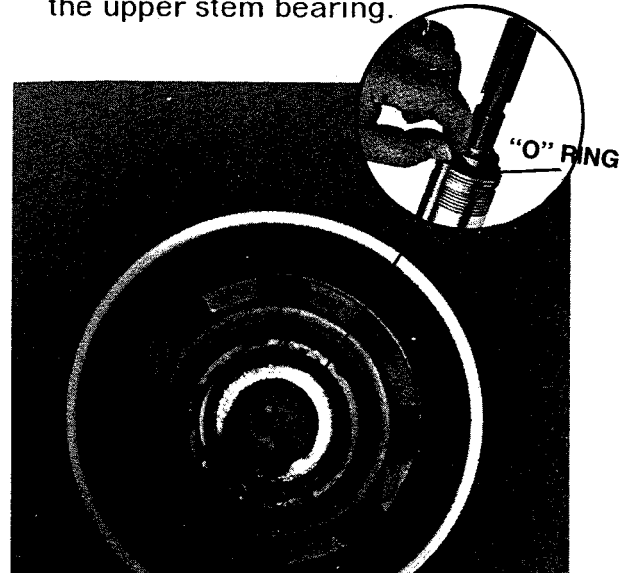

14. Install shaft seal, retaining washer and snap ring into the mounting stem.

15. Reinstall agitator and lock in place by tightening set screw.
16. Reinstall washer, level and check for proper operation.

## LIP SEAL

A lip seal is used to keep the oil in the transmission. It is located at the bottom of the transmission and is pressed into a bore in the center tube. The center shaft is inserted through the seal. The lip of the seal presses against the center shaft creating a seal to keep the oil inside the transmission.

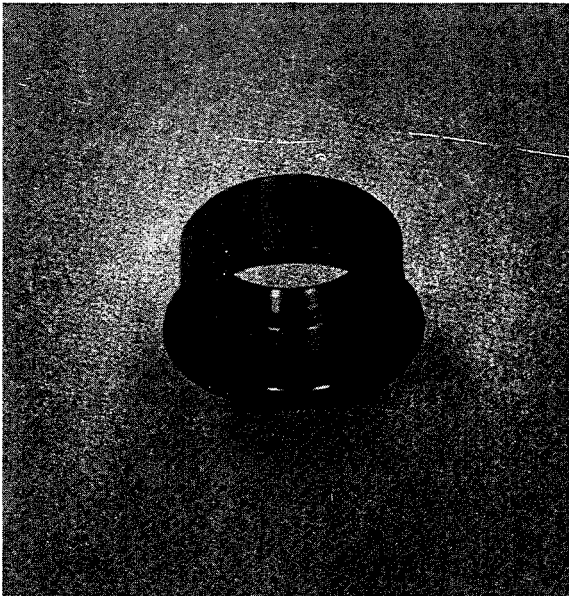

It is only necessary to remove the drive pulley to gain access to the lip seal.

### Removing the seal:

1. **Disconnect electrical power to washer before servicing.**
2. Tip washer to gain access to bottom pulley. Remove dust cover from center of pulley. Remove #2 Phillips screw & lock washer from bottom of drive shaft.

3. Pry drive lug off drive shaft.
4. Spin drive pulley off shaft (ccw from bottom).

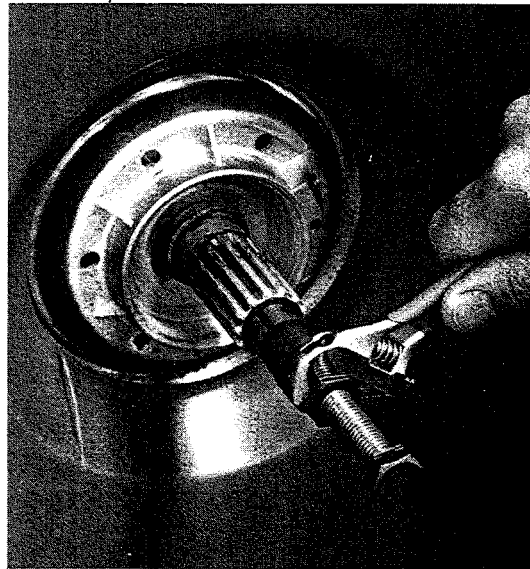

5. Use the lip seal tool part number 038228 to remove the lip seal from the center tube. This tool is screwed into the lip seal and the lip seal is removed by turning the bolt against the center shaft.

**Note:** You may need to hold the transmission when tightening the lip seal tool and when replacing the lip seal to keep the transmission from rotating.

6. Clean lip seal bore in the center tube with choke cleaner to remove any oil. Make sure area is clean and dry.
7. Press new lip seal over Seal-Protector. The Seal-Protector is designed to protect the seal area of the lip seal from rolling over or tearing as the seal is pressed into the center tube of the transmission.
8. Slide assembly over square thread of center shaft until the lip seal starts into the center tube bore.

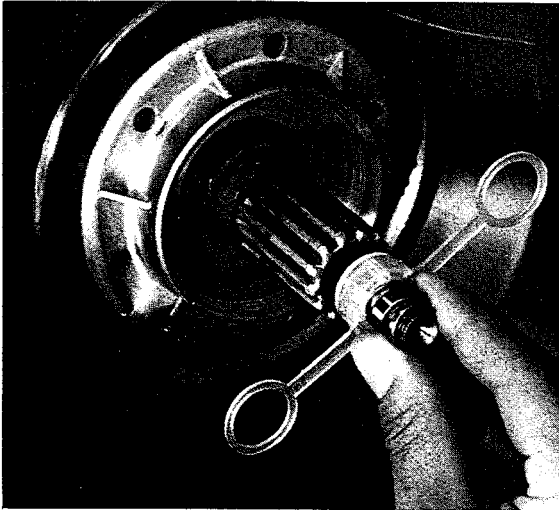

9. Turn drive pulley onto the center shaft and against Seal-Protector. Tighten pulley to press lip seal into center tube bore. Back pulley off and check to make sure lip seal is pressed into position (flange of lip seal should be against end of center tube).

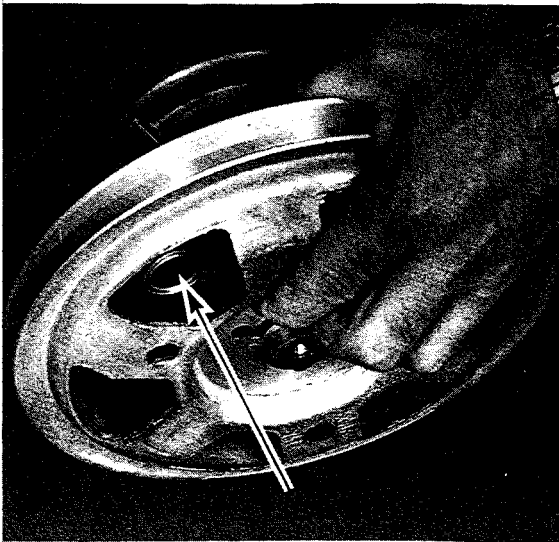

10. Remove pulley.
11. Using the loops, remove Seal-Protector and discard.
12. Replace pulley and belts. Be sure rotor bearing is on drive pulley correctly with "cup" of bearing over hub of pulley.
13. Place washer in upright position. Replace front panel and remove tub

block. Connect washer and check for proper operation.

---

## DAMPER ASSEMBLY

The damper assembly consists of a damper, tub support arms and centering springs.

---

### Damper Pads

Dry or poorly lubricated damper pads can result in a rubbing noise during the beginning and end of the spin cycle. If this condition is encountered, the damper pads should be lubricated or replaced.

When you order damper pads and/or a damper or a base, a quantity of silicone grease is also provided. The quantity is sufficient to lubricate the three damper pads. The silicone grease should be applied by hand and should thoroughly cover each pad. Over lubrication is not necessary. Although only a small amount of grease is furnished in the container, it is adequate to do the job.

#### To replace or lubricate damper pads:

1. **Disconnect electrical power to washer before servicing.**
2. Remove two screws holding front panel and remove front panel.
3. Remove two bolts holding top cover and raise top cover.

**Note:** Tape lid to prevent it from striking the control panel.

4. Remove nuts from three eyebolts. The position of the nuts on the eyebolts can be marked by placing

strips of electrical tape around bolts above nuts before loosening.

5. Remove drive belt.
6. Tip washer back and lay a 4" x 4" wood block under drive pulley.
7. Set washer down on top of the wood block.

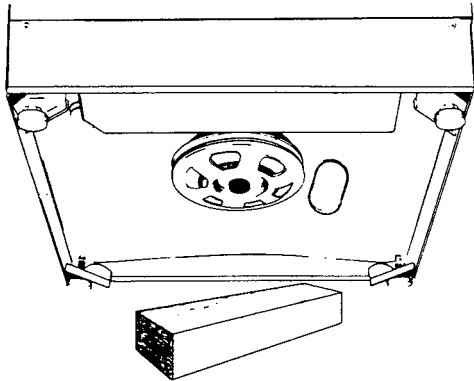

8. The complete assembly of the tub and damper should be pushed up from the base far enough to get to the damper pads.

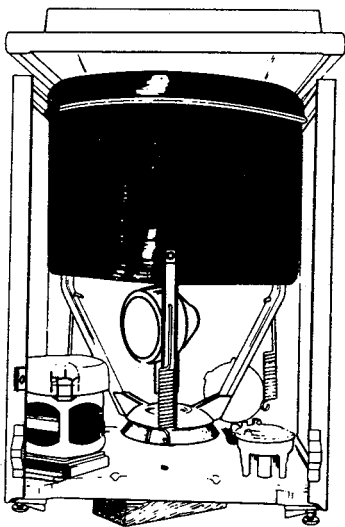

9. Scrape old pads from base.
10. Use a degreasing agent such as alcohol to remove any grease from area.

11. Apply rubber adhesive part number 055978 to area where old pads were removed.
12. Apply pads to base and let dry. The top surface of pad should be located  $\frac{3}{32}$ " below center opening in base. The distance between pads should be about  $\frac{5}{8}$ ".

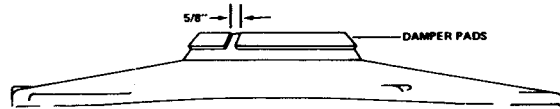

13. Lubricate damper pads with silicone grease part number 204999.
14. Assemble washer.
15. Check tub centering and adjust if necessary (refer to section on tub centering).

---

## Damper Replacement

### If damper replacement is needed:

1. Disconnect the electrical supply to the washer.
2. Remove front panel.
3. Remove all hoses from outer tub.
4. Lay washer on its back (secure lid to top).
5. Remove belts, pulley and brake package.

6. Place washer in an upright position and remove nuts from centering springs (mark location)
7. Lift entire assembly, tubs, transmission and damper, out of the washer and lay on the floor. Use caution when doing this.
8. Remove the bolts from the damper ears that hold the tub braces.
9. Lift damper clear of the tub braces and remove from washer.
10. Install new damper using reverse order. Make sure boss for retainer clip is aligned toward pump.

---

## BRAKE PACKAGE AND RADIAL BEARING

### DRY BRAKE

The normal symptom of a dry brake package is a screeching noise at the end of the spin cycle as the tub comes to a stop.

The brake can be lubricated without removing it from the washer.

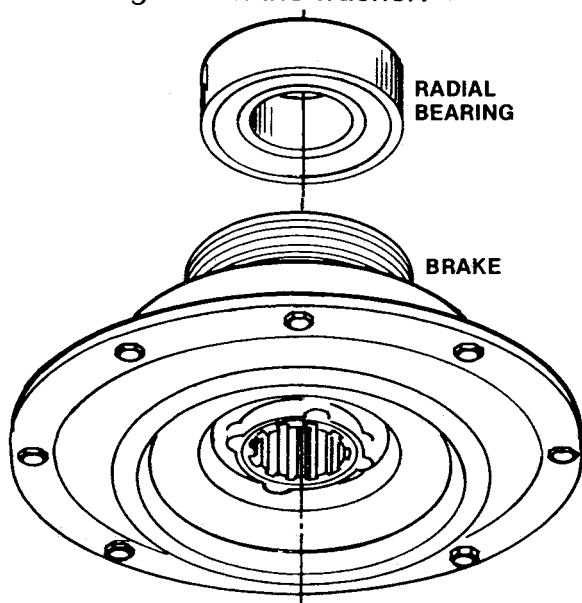

### To Lubricate Brake:

1. **Disconnect the electrical supply to the washer.**
2. Put tub block in tub and lay washer back far enough to get to the pulley and brake.
3. Remove drive pulley.
4. Use pulley dust cover as measure and squeeze two capfuls of part number 056080 transmission oil over brake package lip.
5. Put the pulley on the shaft and turn until the brake is disengaged. With the brake disengaged, the oil will run into the brake package. Turn the pulley several times to insure proper lubrication. Reset stop lug and install dust cap.

### BRAKE DISASSEMBLY

The brake must be released before the washer will spin. If the brake is stuck it won't release. In this case, the brake must be repaired or replaced.

After drive pulley has been removed, the brake assembly can be removed as follows (power unit in place):

1. **Disconnect the electrical supply to the washer.**
2. With tub block in place, the tubs and power unit will be parallel with the cabinet. Remove hex bolt and retainer clip in damper holding the brake package.
3. Use the brake tool, part number 38315 to unscrew the brake package assembly from the damper. When the brake package is free, pull out to disengage it from the spline surface of the drive tube. The brake package is accessible now for disassembly and repair.

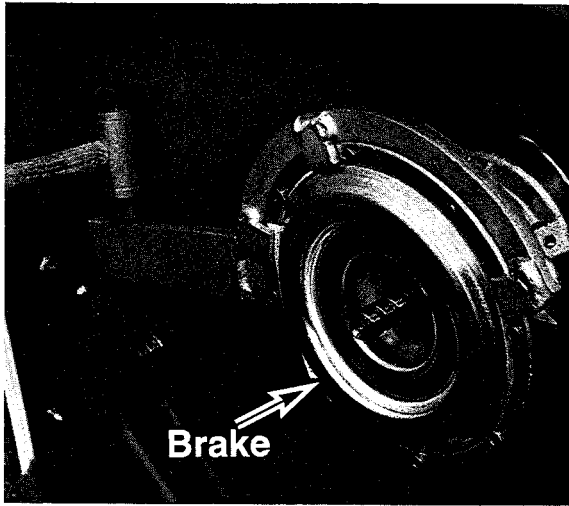

4. After brake package has been removed, the radial bearing may be removed from top of brake package.



## To Disassemble the Brake Package:

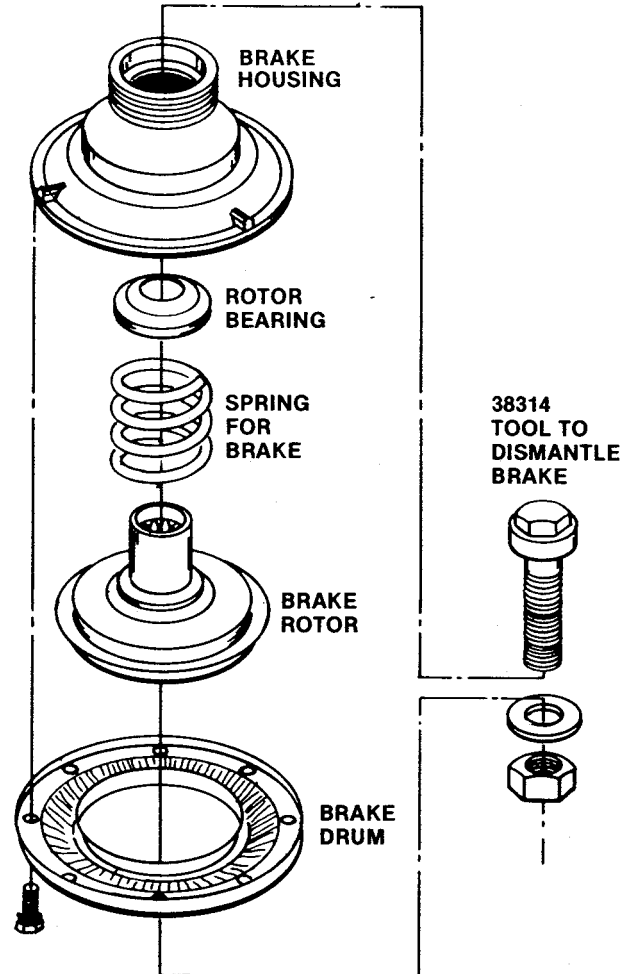

The brake assembly contains a spring which is partially compressed and exerting 200 lbs. pressure. Use part number 038314 tool to dismantle brake. Because of this spring, CAUTION MUST BE TAKEN when disassembling the units.

Use tool to dismantle brake, part number 038314, to hold brake package spring prior to dismantling the brake package. Remove screws holding brake package together then slowly loosen the 038314 compression tool until the spring tension is completely released. Brake components are now accessible for service. Reassemble by reversing the procedure.



When reassembling the brake, fill the 211038 rubber dust cap which fits over the end of the drive pulley with 056080 transmission oil. Then pour the oil over the lip of the brake package and replace the dust cap. Use two capfuls.

#### **To Replace Brake Package:**

1. Place radial bearing in top of brake package.
2. Insert brake package over drive tube splines.
3. Start threads of brake package into damper turning in by hand.
4. Be sure that tub block is in place keeping tubs level so as to prevent binding on brake package threads.
5. When turning brake package into the damper, allow power unit to turn so that you do not have to overcome the friction of the brake.
6. When threaded tight, use the brake tool 038315 and hammer to seat brake package firmly in place.
7. Locate retaining clip and tighten damper bolt securely into damper.

**Note:** Once the brake has been reinstalled, turn the pulley on the shaft until the brake is disengaged. With the brake disengaged, the oil will run into the brake package. Turn the pulley several times to insure proper lubrication.

#### **To Service the Brake without Removing it from the Washer:**

1. Remove drive pulley.
2. Replace every other brake drum retainer screw (total of eight) with a 1 1/2" long 8-32 machine screw. Snug these screws up against brake drum.

3. Remove the four remaining brake drum screws and then alternately loosen the four long machine screws just inserted. The idea is to lower the brake down evenly to avoid bending it.
4. As the screws are loosened, the brake spring will reach the limit of its extension. You will run out of spring pressure before you run out of screw thread. Remove brake drum and gasket.
5. Pull brake rotor assembly from spin tube spline. Inspect liner for wear or damage. Replace if questionable.
6. Wipe inside of brake housing before reassembly.
7. Inspect spring cap for wear. Wear indicates sticking radical bearing.
8. Apply grease to inside of rotor splines before reassembly. Use new gasket.
9. Tighten machine screws alternately to compress brake drum back to housing. Install four original screws and replace "service" screws.
10. Add two ounces of 56080 oil over lip of brake drum.

---

## **DRIVE PULLEY AND ROTOR BEARING**

The drive pulley must be removed to gain access to the rotor bearing or to remove the brake package.

#### **To Remove Pulley:**

1. **Disconnect the electrical supply to the washer.**
2. Remove drive and pump belts and rubber cap covering hub of pulley.

3. Remove screw and washer from bottom of drive shaft.
4. Remove the splined drive lug from the drive shaft.
5. Turn pulley counterclockwise to remove it from the helical shaft. The rotor bearing is located above the drive pulley.

**Note:** There is a top and bottom to the rotor bearing. When it is positioned correctly, the top of the bearing and the pulley hub will be about even (the concave side against pulley hub).

**WARNING**

*If you put the rotor bearing on upside down, you will have no brake.*

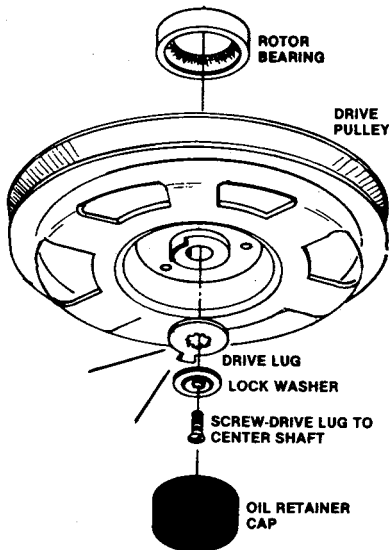

**Note:** When the drive pulley is replaced, the drive lug must be properly positioned.

**To Adjust Drive Lug:**

Turn the drive pulley onto the shaft clockwise until all play is taken up.

Holding the pulley in this position, the distance between drive and pulley lugs should be 3/8". Turn pulley counterclockwise and check to see that the drive lug and pulley are making contact.

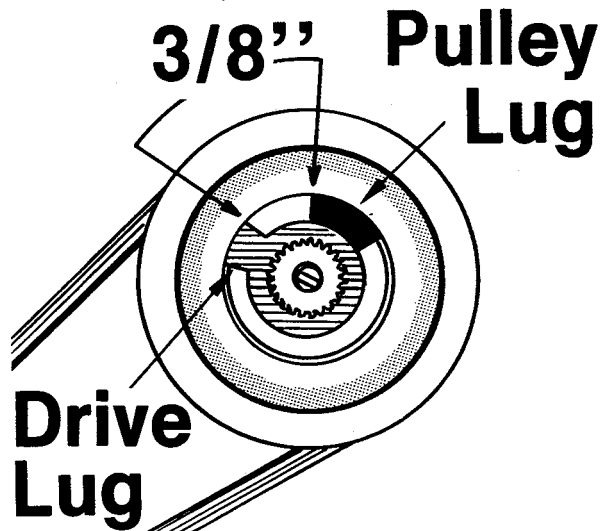

**CAUTION:**

*There should always be a clearance between the bottom of the pulley and the top of the stop lug to prevent the drive pulley from dragging on the drive lug, forcing it off the shaft.*

**BELT GUARD**

The belt guard is secured to the front panel by three sheet metal screws through the long lip of the belt guard and lower lip at the base of the front panel.

Attaching the belt guard in this manner makes it unnecessary to remove it from the front panel since it will be automatically removed and replaced with the front panel.

---

## POLY PUMP

The poly pump will pump the water out of the tub to the drain during spin.

The direction of the pump impeller rotation depends on rotational direction of the motor since the pump is belt driven from the motor. During agitation the pump impeller is turning in a clockwise direction with the water being forced back into the washbasket. During spin the impeller turns in the counterclockwise direction for pump out.

### To Remove the Pump:

1. Disconnect the electrical supply to the washer.
2. Disconnect hoses from pump.

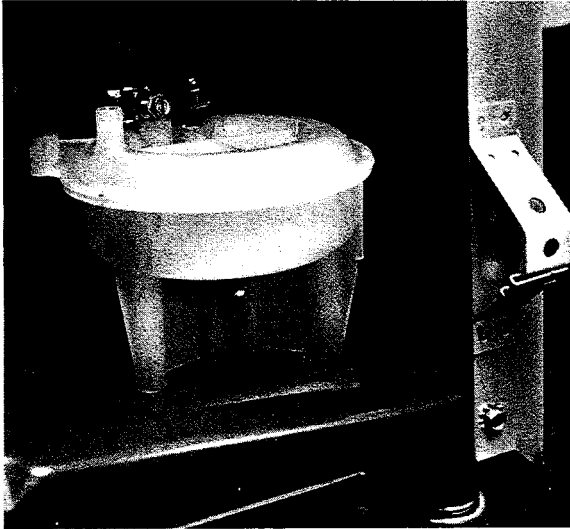

3. Tilt washer and remove pump belt.
4. Remove three screws from bottom of base holding pump to base. The mounting holes for the pump on the base frame are slotted for adjust-

ment of the pump belt. Note general position of pump before removing.

5. Tilt pump and lift through access hole in base frame.

---

## PUMP BELT

### Adjustment of Pump Belt:

1. Disconnect the electrical supply to the washer.
2. Pull motor forward so drive belt is tight.
3. With washer in an upright position, grasp the pump belt in the middle and flex. With the belt flexed, it should be tightened so that there is approximately 1/4" between the inside surfaces of the pump belt before movement of the motor is felt.

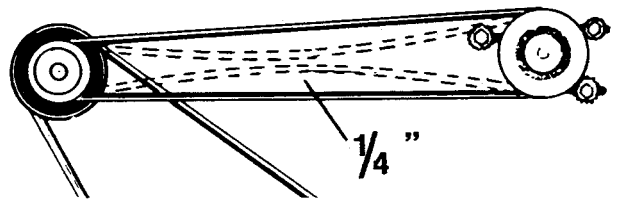

4. If necessary, tilt washer and loosen screws holding pump to base frame and position pump to attain the proper 1/4" dimension.

---

## DRIVE MOTOR AND MOTOR BASE

The motor base consists of an upper and lower section. The lower section is mounted to the base and remains stationary.

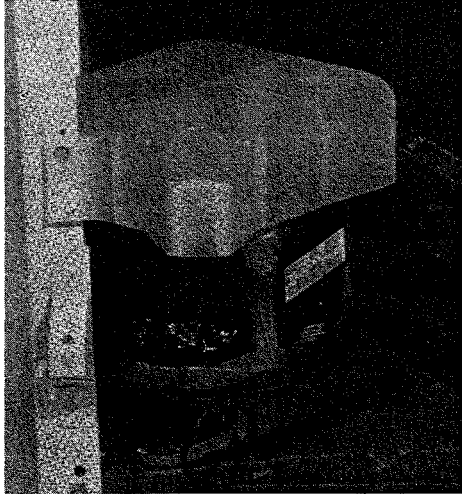

The upper section is used to mount the motor. The upper section has four square glides which engage in a track on each side of the lower section. Two tension springs are attached between the two sections.

During agitation the pulley turns in a clockwise direction as viewed from the top of the motor. The motor is pulled towards the front of the washer causing the motor pulley to tighten against the drive belt.

During the spin, the motor turns in a counterclockwise direction. The initial surge caused by the reverse torque of the motor pulls the motor along the track to the rear. The drive belt slips in the motor pulley so the motor does not absorb the full starting impact and weight of the full tub.

As the inertia of the tub is overcome, the motor is pulled forward by the tension springs allowing the drive belt

to settle into the motor pulley and gradually build up spin speed. The drive belt tension during spin is automatically provided by the two motor tension springs. The drive belt serves as a clutch.

---

### Motor Ground Wire

A 7" green ground wire is attached to the right-hand front of the motor carriage to the washer base. This ground wire provides additional protection to the service technician. To maintain all grounding provisions provided with the appliance, the ground wire must be reinstalled any time removal of the wire is required.

---

### Motor Shield

All washers use a polypropylene motor shield. The polypropylene shield is molded in the form of a circular cover and is secured to the cabinet with one screw.

The purpose of the shield is to keep water off of the motor in the event of a leak. If a motor is removed, the shield should always be put back in place.

### MOTOR FAILURES

If the washer won't agitate or spin, check motor with a motor test cord. This cord enables you to check the motor (without removing it) independent of other components.

**Disconnect the electrical supply to the washer.** Connect cord as shown in the following drawings.

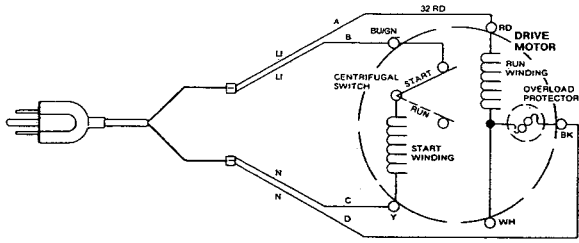

**AGITATE**

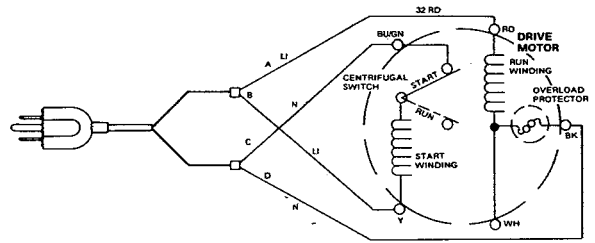

**SPIN**

## MOTOR REMOVAL

The drive motor is attached to the upper section of the motor base by the motor thru-bolts and nuts. Motor replacement necessitates removing the motor base from the washer base.

1. **Disconnect the electrical supply to the washer.**
2. Remove two screws holding front panel and remove panel.
3. Remove motor cover.
4. Remove machine harness wires from motor switch terminals.
5. Remove belts.
6. Remove three screws holding motor base to base frame and remove motor base and motor.
7. Remove motor pulley.
8. Disengage tension springs and remove mounting nuts. (To remove two of the nuts, align upper and lower sections and insert wrench through the slots into lower section.)

To remove motor from bracket, stand motor (shaft up) and lift off. With motor removed, carriage and rollers are accessible for service.

Clean the motor base of any dirt or lint. Replace motor on motor base and to

base frame. Lubricate the track and glides with Maytag poly grease. When motor base is attached to base frame, mount with slotted end of lower carriage to the back. Reattach motor ground wire.

After the motor has been replaced, it will not be necessary to check or make a drive belt adjustment as the correct tension is automatically applied by the two motor tension springs. It will, however, be necessary to check the pump belt for proper adjustment.

---

### Motor Tension Springs

**Note:** Replacing the tensions springs involves working around an electrical component - the motor. If replacing the tension springs, always unplug the washer from the power source to avoid any chance of electrical shock.

The motor tension springs may be removed and replaced without removing the motor base from the base frame. This may be done by using needle nose pliers and disengaging the spring hooks from the tabs and lower section. Both springs are on the left side of the motor shaft.

## SECTION 3. SET-UP AND PROGRAMMING PROCEDURES

### "PD" CONTROL SET-UP PROCEDURE

#### IMPORTANT

Read all instructions before operating.

#### Introduction:

The lower fabric setting pads, along with the digital display, are used to set-up the MAT10PD controls.

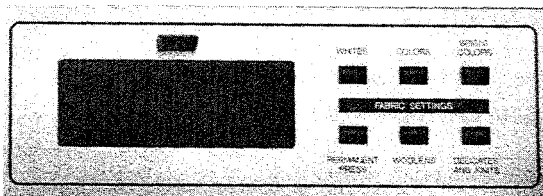

Following is a step by step procedure which must be followed.

#### How to Read the Display

After the unit has been installed and plugged in, the display will show "0" minutes remaining.

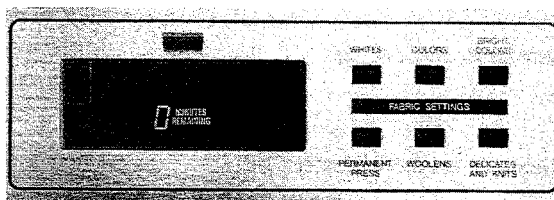

The display can contain three (3) numbers and/or letters and a decimal

point following the first character. The far left character and the decimal point are used to indicate 1 of 22 set-up codes available for use in programming the appliance for a specific function. Only the appropriate codes will be shown. The two(2) right digits are used to provide information about the code shown.

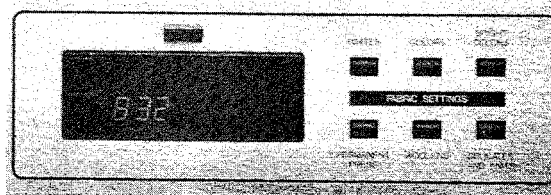

#### How to Use the Key Pads to Program the Controls

1. The *Permanent Press* key pad is used to advance within the codes permitting adjustment for programming. Pressing the key pad will change the characters by one (1). Rapid adjusting is possible by holding the key pad down.
2. The *Woolens* key pad will advance you through the codes that are set-up in the appliance. Pressing the key pad will advance you through the programmed codes. Holding the key pad down will automatically advance through programs at a rate of one (1) per second.
3. The *Delicates & Knits* key pad is used to select options for Cycle Count, Money Count and Special Pricing. This is essentially an "OFF" or "ON" selection.

## START OPERATING SET-UP

Insert access door key and turn counterclockwise and lift to remove access door.

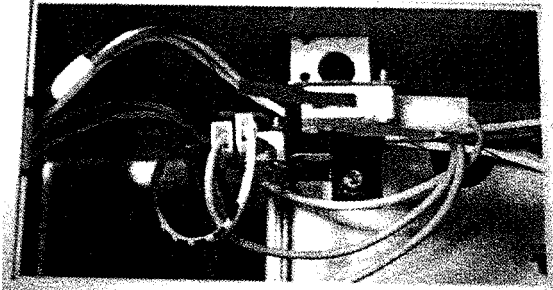

*You are now ready to enter the set-up code.*

Before proceeding, it is worth noting that even with all of the options available, an owner can simply choose to uncrate a new commercial machine, hook it up, plug it in and have a unit which operates.

**Note:** Units are preset at the factory. The washer is set for 10 minutes wash and one deep rinse for \$1.75.

## SET-UP CODES

The set-up code is indicated by the first two right hand characters. The program code is the first left character.

CODE		EXPLANATION
607	6	REGULAR CYCLE PRICE
	07	Represents the number of coins. See value of Coin 1 and Coin 2. Adjustable from 0-99 coins by pressing the Permanent Press key pad.  Press <u>Woolens</u> key pad once to advance to next code.
710	7	WASH & AGITATION CYCLE
	10	This is the number of minutes for <u>Wash &amp; Agitation</u> . Adjustable from 8-15 minutes by pressing the <u>Permanent Press</u> key pad.  Press <u>Woolens</u> key pad once to advance to next code.
811	8	RINSE CYCLES
	11	Represents the length and number of rinses except for woolens and delicates. The middle digit is the approximate length of rinse agitation and the last digit is number of rinses. The approximate length of rinse can vary from 1 to 4 minutes and the number of rinses from 1 or 2. <u>Refer to chart "Rinse Cycles"</u> .  Advance the Rinse option by pressing <u>Permanent Press</u> key pad.  Press <u>Woolens</u> key pad once to advance to next code.
900	9	CYCLE COUNTER OPTION
	00	If "0C" is selected as the option it may not be deselected "00".  Not Selected or "OFF".



	0C	Selected or "ON". Press <u>Delicates &amp; Knits</u> key pad three consecutive times to select "ON".
		Press <u>Woolens</u> key pad once to advance to next code.
<b>1.00</b>	1.	MONEY COUNTER OPTION
		If "0C" is selected as the option it may be deselected "00".
	00	Not Selected or "OFF".
	0C	Selected or "ON". Press <u>Delicates &amp; Knits</u> key pad three consecutive times to select "0C" and three consecutive times to deselect "00". Reset counter by going from OFF to ON.
		Press <u>Woolens</u> key pad once to advance to next code.
<b>2.00</b>	2.	SPECIAL PRICING OPTION.
		This option can be selected "SP" or deselected "00".
	00	Not Selected or "OFF".
	SP	Selected or "ON". Press <u>Delicates &amp; Knits</u> key pad once to select "SP".
		Steps "3." thru "9." codes are skipped if mode "2.00" is selected.
		Press <u>Woolens</u> key pad once to advance to next code.
<b>3.07</b>	3.	SPECIAL CYCLE PRICE
	07	Represents the number of coins. Adjustable from 0 to 99 by pressing the <u>Permanent Press</u> key pad.
		Press <u>Woolens</u> key pad once to advance to next code.
<b>4.</b>		"This number is not used".
<b>5.00</b>	5.	MINUTES
	00	This is the selection "minutes" of the time of day clock. Adjustable from 0 to 59 by pressing the <u>Permanent Press</u> key pad.
		Press <u>Woolens</u> key pad once to advance to next code.
<b>6.00</b>	6.	HOUR
	00	This is the selection "HOUR" of the time of day clock using military time (24 hour clock). Adjustable from 00 to 23 by pressing the <u>Permanent Press</u> key pad.
		Press <u>Woolens</u> key pad once to advance to next code.
<b>7.00</b>	7.	SPECIAL PRICING STARTING HOUR
	00	This is the selection of the hour using military time (24 hour clock) that the Special pricing will "begin". Adjustable from 00 to 23 by pressing the <u>Permanent Press</u> key pad.
		Press <u>Woolens</u> key pad once to advance to next code.

8.00	8.	SPECIAL PRICING STOPPING HOUR
	00	This is the selection of the hour using military time (24 hour clock) that the Special pricing will "stop". Adjustable from 0 to 23 by pressing the <u>Permanent Press</u> key pad.
		Press <u>Woolens</u> key pad once to advance to next code.
9.10	9.	SPECIAL PRICE DAYS
	10	Represents the day of the week and if special pricing is to occur on that day. The middle digit is the day of the week, and the last digit is "0" for <u>not selected</u> or "S" for <u>selected</u> .
		For example:
		9.10 Special pricing not selected.
		9.1S Special pricing selected for that individual day.
		Pressing the <u>Delicates &amp; Knits</u> key pad once to select "0" and once for "S".
		Press <u>Permanent Press</u> key pad to advance to next day of the week.
		You must exit on current day of the week it is, for the special pricing to occur on the correct day. <u>Refer to chart for Special Price Days</u> .
		Press <u>Woolens</u> key pad once to advance to next code.
A.00	A.	VAULT VIEWING.
		Once selected (SC), this option may be deselected (00).
	00	Not Selected or "OFF".
	SC	Selected or "ON".
		Press <u>Delicates &amp; Knits</u> key pad once to select "SC", the money and/or cycle counter will be viewable when the vault is opened. If "00" is selected, the service door will need to be opened to activate, to view the money and/or cycle counter.
		Press <u>Woolens</u> key pad once to advance to next code.
b.05	b.	VALUE OF COIN 1 (QUARTER DROP)
	05	Represents the number of nickels (5 cent increments) given to the <u>value of each coin</u> in code 607 "regular cycle price" or "special cycle price".
		For example:
		b.05 equals five nickels or one quarter.
		b.20 equals twenty nickels or one dollar.
		Press <u>Permanent Press</u> key pad to advance from 1 to 99 in nickels.
		Press <u>Woolens</u> key pad once to advance to next code.
C.20	C.	VALUE OF COIN 2 (CANADIAN DOLLAR DROP)

20 Represents the number of nickels (5 cent increments) given to the value of each Canadian Dollar drop in the dollar coin slot.

For example:

C.20 equals twenty nickels or one Canadian dollar.

C.40 equals forty nickels or two Canadian dollars.

Press Permanent Press key pad to advance from 1 to 99 in nickels.

Press Woolens key pad once to advance to next code.

d.00

d. COIN SLIDE OPTION.

Once selected (CS) this option may be deselected (00).

00 Not Selected or "OFF".

CS Selected or "ON".

Press Delicates & Knits key pad once to select "00" when coin drop is used, and "CS" for models not using coin drops.

Press Woolens key pad once to advance to the beginning of the program mode.

## RINSE CYCLES

In reference to the "Rinse Cycles", the following will appear when programming that sequence:

Code	Minutes of Rinse	Number of Rinses
811	One	One
821	Two	One
831	Three	One
841	Four	One
812	One	Two
822	Two	Two
832	Three	Two
842	Four	Two

## SPECIAL PRICE DAYS

In reference to the "Special Price Days" the following will appear when programming that sequence: (The number "5" is read as an "S" to represent special pricing in effect).

Not Selected	Selected	Day Number	Day of Week
9.10	9.15	Day 1	Sunday
9.20	9.25	Day 2	Monday
9.30	9.35	Day 3	Tuesday
9.40	9.45	Day 4	Wednesday
9.50	9.55	Day 5	Thursday
9.60	9.65	Day 6	Friday
9.70	9.75	Day 7	Saturday

**Note:** Remember you must show current day of week before preceding to next code.

## Cycles and Money Counter Options

The following will appear if you selected "0C" in the cycle counter option "900". This is a "View Only" and cannot be altered.

When cycle counter is selected, the numbers will "flash" in sequence.

**Example:**

100	Represents number of cycles in HUNDREDS	102 = 200
200	Represents number of cycles in ONES	225 = 25
		TOTAL = 225 Cycles

Press **Woolens** key pad once to advance to next code.

The following will appear if you selected "0C" in the money counter option "1.00". This is a "VIEW ONLY" and cannot be altered. The money count can be reset by going to OFF (00) and ON (0C).

When money counter option is selected, the numbers will flash in sequence.

**Example:**

300	Number of dollars in HUNDREDS	301 = 100
400	Number of dollars in ONES	468 = 68
500	Number of CENTS	575 = 75
		TOTAL = \$168.75

---

## WASHER DIAGNOSTIC MODE

The mode is entered by depressing **Delicates & Knits** key pad for one second while in any of the set-up modes one through six or with a fault code present. Fault codes are cleared on entry and all display segments should flash.

If a fault code persists, the fault must be corrected before the diagnostic cycle will start. With all segments flashing, the diagnostic cycle is started by depressing the **Woolens** key pad.

The cycle is three seconds of cold fill (a 'C' is displayed), three seconds of hot fill (an 'H' is displayed), three seconds of agitation (a 'A' is displayed), and ten seconds of spin (an 'S' is displayed). The **Woolens** key pad can be used to pause/resume this diagnostic cycle. The **Delicates & Knits** key pad will cancel this cycle and exit the diagnostic mode.

A **free cycle** may be given by pressing **Permanent Press** key pad, "CC" will be displayed. When you exit the service mode "Select Cycle" will be displayed.

## FAULT CODES

If the set-up code is entered and one of the following circumstances has occurred, the appropriate fault code will be in the display.

<b>F1</b>	Water level circuit failure on control board (machine non-functional).
<b>F4</b>	Lid switch circuit failure on control board (machine non-functional).
<b>F5</b>	Blocked coin 1 or coin drop control circuit failure (machine non-functional).
<b>F7</b>	Slow fill detected; fill time greater than 5 minutes (machine functional).
<b>F8</b>	Slow drain detected; drain time greater than 2 minutes (machine functional).
<b>F9</b>	Low voltage detected; less than 90 volt AC (machine functional).
<b>F12</b>	Motor sensor circuit failure on control board (machine functional).
<b>F13</b>	Blocked coin 2 or coin drop control circuit failure (machine non-functional).
<b>Note:</b> Non-Functional - machine will not operate. Functional - machine will operate.	

## GENERAL USER INFORMATION

**Blank Display:** This condition indicates that the appliance is inoperative or no power. Coin box could be full.

**0 Minutes Remaining:** When this shows in the display, it indicates that the appliance cannot be operated. If coins are deposited during this condition they will be stored in escrow and cannot be used for the next cycle until normal operation is restored by opening and then closing the lid. If the lid switch contacts do not open, recovery from this condition is impossible without repair.

## "DA" SET-UP & USE INSTRUCTIONS

### Note

**Set-up and use instructions for the MEQ, accompany each hand-held computer.**

When installing the washer, the pricing can be set-up without the use of the MEQ hand-held computer.

## SET-UP

### Important

**Make sure electrical power is disconnected before removing control panel.**

1. Remove the control panel by removing the two top corner security screws.

2. Lay the control panel forward in order to gain access to the circuit board enclosure.
3. Unsnap the circuit board cover by pulling up on it. Now the board is exposed.

**Note:** Ground yourself by touching an exposed screw on the control panel before touching circuit board.

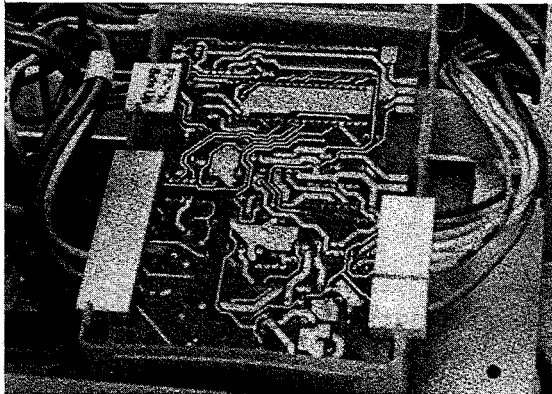
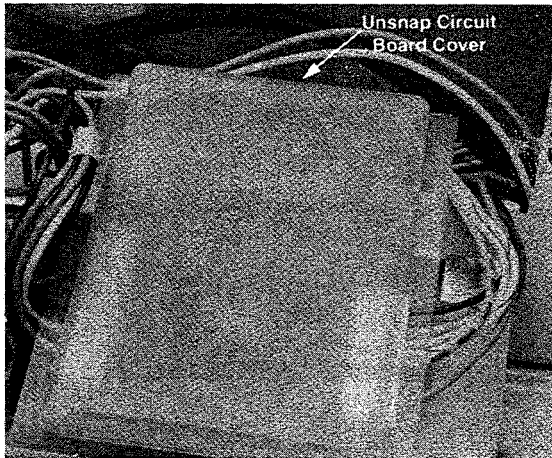

4. Tilt the board up exposing the dip switches. Now set the switches

according to the following section entitled "Switch Settings."

5. Once the switches have been set as you desire, carefully lay the board back into the circuit board enclosure and snap the cover back in place.
6. Reinstall the control panel by reversing the procedure given in the first two steps.

---

## BATTERY CONNECTION

The data acquisition control retains its memory during power outages by means of a battery mounted on the control board

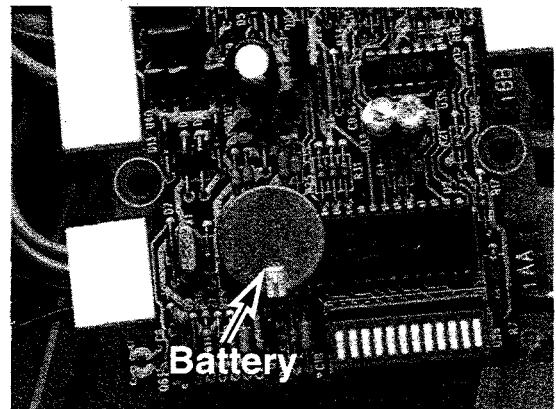

---

## SWITCH SETTINGS

This appliance has many set-up variables which can be set using a hand-held MEQ. However, to allow for the use of these machines without the use of an MEQ, some set-up variables can be set by changing the dip switches mounted on the control board.

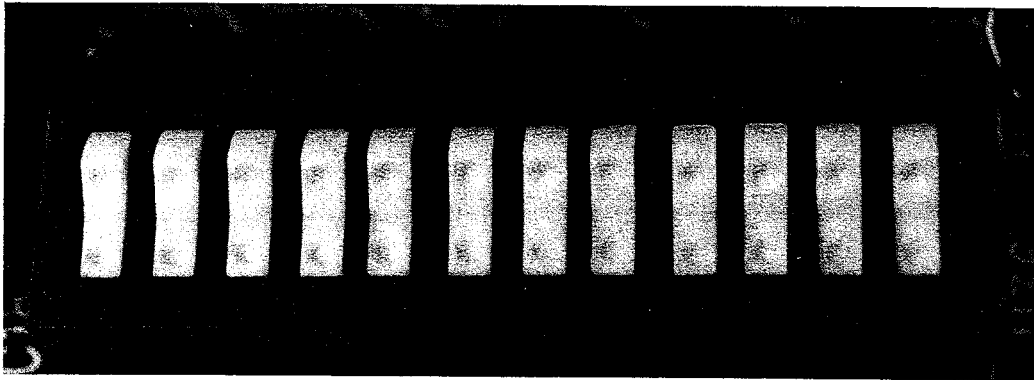

---

### Washer Coin Settings

The following table contains switch setting definitions. The first seven switches are relevant to both the washer and dryer.

*The first setting is made with switches 1-5 as follows: (The number of coins it takes to start a cycle.)*

Washer: Cycle price = \$0.75  
Coin1 Value = \$0.25  
Coin2 Value = \$1.00

#### Table Information:

1 = Switch in ON position  
0 = Switch in OFF position (OFF = OPEN)



Switch Setting												# Of Coins (coin1) Per Cycle
1	2	3	4	5	6	7	8	9	10	11	12	
0	0	0	0	0								default *
0	0	0	0	1								1
0	0	0	1	0								2
0	0	0	1	1								3
0	0	1	0	0								4
0	0	1	0	1								5
0	0	1	1	0								6
0	0	1	1	1								7
0	1	0	0	0								8
0	1	0	0	1								9
0	1	0	1	0								10
0	1	0	1	1								11
0	1	1	0	0								12
0	1	1	0	1								13
0	1	1	1	0								14
0	1	1	1	1								15
1	0	0	0	0								16
1	0	0	0	1								17
1	0	0	1	0								18
1	0	0	1	1								19
1	0	1	0	0								20
1	0	1	0	1								21
1	0	1	1	0								22
1	0	1	1	1								23
1	1	0	0	0								24
1	1	0	0	1								25
1	1	0	1	0								26
1	1	0	1	1								27
1	1	1	0	0								28
1	1	1	0	1								29
1	1	1	1	0								30
1	1	1	1	1								Free mode

**Note:** If the switches 1 thru 5 are all in the OFF position, then default values are adopted regardless of the position of switches 6 thru 12.

*The second setting is made with switches 6-7 as follows: (This sets the value of the coins to be accepted.)*

1	2	3	4	5	6	7	8	9	10	11	12	value of coin "1" (right)	value of coin "2" (left)
						0	1					\$0.10	\$0.25
						1	0					\$0.25	\$1.00

This appliance will operate based upon the switch settings until the first time an MEQ set-up is executed on the machine. Following this event, the switches are no longer used and are completely ignored.

The settings from 8 to 12 do not apply to washers. To complete installation, return to step 5 of the section entitled "Set-up."

# OPERATIONAL INSTRUCTIONS

## How to Use

1. Load clothes.
2. Select the desired cycle by turning the selector knob.
3. Insert coin(s).

If the Add Coins LED flickers briefly when a coin is dropped, then it is considered a good coin and is counted. Once the designated number of coins satisfies the cycle price, the LED will turn off.

4. The washer will start the cycle if the lid is closed; or to start the dryer cycle, close the door and press the Push to Start button.

## GENERAL INFORMATION

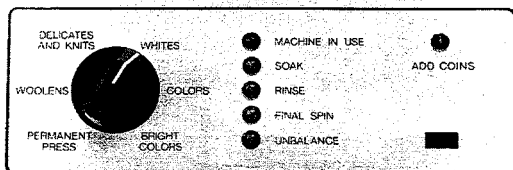

This section covers questions that may arise about the washer.

### ADD COINS LED:

The Add Coins LED will be off when one of the following takes place:

- A cycle is in process.
- The coin vault switch is not closed (vault drawer is removed, or open).
- The optic switch on the coin drop has been blocked for more than 8 seconds.
- A service cycle is in process.
- The appliance is in free-mode.
- Certain fault conditions exist.
- No power is available to the appliance.

**Washer:** The Add Coins LED will only be on when there is not enough money in escrow for a cycle, and none of the previous conditions have been satisfied.

The washer will not start filling for a new cycle unless the lid has been opened and closed since the last cycle was completed.

The washer will only fill with the lid closed.

### FREE CYCLE:

**Washer:** If the washer is in the free-mode, the Add Coins LED will be off.

### SPECIAL PRICING:

**Washer:** The washer will indicate that it is in a special pricing mode with a slow blinking of the Add Coins LED. Special pricing can only be set-up with an MEQ hand-held computer.

### ANTI-CHEAT MODE:

**Washer:** The coin sensor measures the size of the coin as it goes by the sensor. If the coin takes too long, the machine enters the anti-cheat mode. It is presumed that the cause of the invalid

length blockage is cheating. For the next 15 seconds, all optic blockages including those the length of a valid coin are disregarded under the assumption the cheater is responsible.

If the coin is continually blocked for eight seconds, the Add Coins LED is turned off.

#### **DUAL COIN DROP ONLY:**

The second drop may still be capable of accepting coins.

#### **SERVICE:**

To gain access to the service switch, remove service door at the rear of the vault.

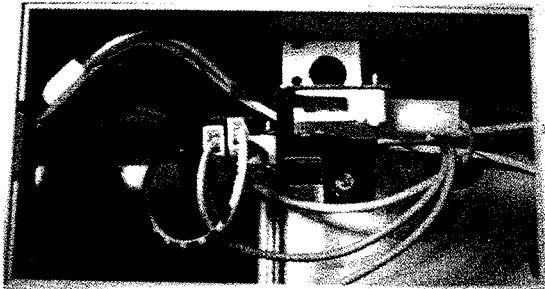

**Washer:** Anytime the service door is opened, the Add Coins LED will flicker for one second.

If the vault or service door is opened, customer money will not be in escrow following a service cycle.

Service cycles may be initiated by:

- *Three or more rapid taps of the service switch.*
- *Dropping coins for full cycle price with the vault or service door open. Remember, any money deposited with the vault or service door open will clear customer money in escrow.*
- *Manually advancing the timer with the vault or service door open (washer only).*

Initiation of a service cycle will cancel any customer cycle.

**Washer:** The washer lid must be opened then closed for the service cycle to start.

A washer service cycle is counted upon completion of the service cycle and is not based on motor run-time, but rather revolution of the timer.



---

## SECTION 4. TROUBLESHOOTING

---

### MECHANICAL TROUBLESHOOTING

There are a number of factors which can contribute to noisy or improper washer operation. Some of these are listed below along with areas to check for possible corrections.

---

#### Vibration Noise

1. Control cover loose
2. Front panel loose
3. Complete washer
  - Weak floor construction (reinforce)
  - Inner tub not centered
  - Damper pads dry

---

#### Operation Noise

1. Noise during agitation
  - Check rotor bearing
2. Noise during spin
  - Check tub bearing
  - Check radial bearing

---

#### Water Leaks

1. Water valve
2. Fill hoses
3. Hose clamps
4. Injector housing

5. Poly pump
6. Boot seal
7. Tub cover loose

---

#### Oil Leaks

1. Clear oil around inside of cabinet; excess oil from tub bearing. Wipe off and wait to see if more develops.
2. Oil under base; wipe off and wait to see if more develops. It is probably excess oil from brake package.
3. Excess oil on helical shaft and in rubber dust cap. Replace lip seal in transmission.

---

#### Failure To Agitate Or Spin

1. Belt broken or off pulley
2. Motor pulley off or loose
3. Transmission

---

#### Poor Spin Out

1. Belt off or broken
2. Stretched motor springs
3. Dry or dirty motor base
4. Kinked drain hose
5. Clothing article between tubs
6. Pump belt too tight

---

#### Spins and Agitates At Same Time

1. Drive lug adjustment
2. Clutch washers in transmission

---

### Freewheeling Inner Tub

1. Rotor bearing in upside down
2. Brake liner loose
3. Tub nut loose

---

### Timer Shaft Hard To Pull Out (MN Model)

1. Oil shaft where it goes into timer housing and work in and out until it loosens up.

---

### Warm Water Temperature Too Cold

1. Increase temperature at hot water heater. Warm is 50/50 mix.
2. Clean inlet screens in hot water hose.

---

### Slow Fill

1. Plugged inlet screens in fill hoses and water valve
2. Inadequate water pressure (should be 30 - 120 p.s.i.)

---

### Water Siphoning Out Of Washer

1. Drain hose not 36" from floor
  - Raise drain hose to 36"
  - Install 2-1112 siphon break

---

## ELECTRICAL TROUBLESHOOTING

The malfunction of an electrical circuit cannot easily be diagnosed unless you first understand how it functions when operating normally. The electrical schematic and wiring diagram includes a cycle sequence chart keyed to the

contacts in the timer, relays and/or control switches.

Timer charts are shown in increments of time, usually 30 seconds, represented by small rectangles in the chart. The timer contacts are numbered as a cam number and also the terminal numbers that feed each contact.

### EXAMPLE:

The schematic for the MAT10CS shows cam 7 contacts are fed by terminals 32 and 10. The function is listed as controlling Regular Spin.

A shaded increment indicates contact closure at that point in the cycle. An open or unshaded increment indicates an open contact at that point.

A cycle chart indicates the cycle progression from the start of the cycle on the left to the end of the cycle on the right.

### BASIC FUNCTIONS

The washer will fill, agitate and spin. All operations (and failures) will fall under one of these functions.

### COMPONENTS

There are two basic categories for electrical components, switches and loads. A switch controls the current path to a load component. Lid switches, selector switches, relays and timers are examples of switching components.

An electrical load uses electricity to perform some function. Timer motors and drive motors convert electricity to magnetic fields and then to mechanical motion. Solenoids use magnetic fields

to push or pull. Lamps convert electricity to light.

The main load components in the washer are the drive motor, the timer motor and the water valve solenoids.

The schematic wiring diagram is followed much like a road map. The lines represent the wiring connections between components. Connections in the wiring are indicated by a small circle or dot. If the lines cross but no dot is present at the intersection, there is no connection. As much as possible,

switches are shown in their normal or most common configuration.

**CAUTION:**

*Some of the tests in this section involve checking for voltages with the product live. Use all cautions when working with live circuits.*

Resistance or continuity testing is done with the product disconnected from power. Failure to do so can result in damage to your meter.

---

## Washer Won't Fill (MN Models)

- Check Power
  - Check Faucets
  - Timer
    - Line 8B to 37 (Push-Pull Switch)
  - Lid Switch
    - UL to 12
  - Check Switch
    - 12 to 8B
  - Timer
    - 37 to 12
    - 12 to 7T
    - 7T to 7A
    - 7T to 3 (Rinse Only)
    - 12 to 13 (P.P. Cool Down Only)
  - Selector Switch
    - 7T to 3 (Except Whites)
    - 7A to 6 (Except Bright Colors & Woolens)
    - 13 to 3 (P.P. Only)
  - Water Valve
    - Check Solenoid Coils
    - Disconnect Power
    - Remove No. 6 Orange and No. 3 Blue/Black from Selector Switch Terminals
    - Take Ohms Reading from End of Orange 6 to 15 Brown on Water Level Switch (this also checks the 12 amp fuse)
    - Checks Hot Solenoid (About 900 Ohms)
    - Take Ohms Reading from End of 3 Blue/Black to 15 Brown on Water Level Switch (this also checks the fuse)
    - Checks Cold Solenoid (About 900 Ohms)
- Note:** Reading from Orange 6 to 3 Blue/Black will check both solenoid coils (in series) - about 1800 ohms.
- Lid Check Fuse
    - If Open, Change Main Lid Switch
  - Water Level Switch
    - Power Disconnected
    - Terminal 20 to 15 (Washer Empty)



---

## Washer Won't Fill (CS & DA Models)

- Check Power
  - Check faucets
  - Lid Switch
    - UL to 12
  - Check Switch
    - 12 to 8B
  - Timer
    - 8B to 37
    - 12 to 7T - 37 to 12
    - 7T to 7A
    - 7T to 3 (Rinse Only)
    - 12 to 13 (P.P. Cool Down Only)
  - Selector Switch
    - 7T to 3 (Except Whites)
    - 7A to 6 (Except Bright Colors & Woolens)
    - 13 to 3 (P.P. Only)
  - Water Valve
    - Check Solenoid Coils
    - Disconnect Power
    - Remove No. 6 Orange and No. 3 Blue/Black from Switch
    - Take Ohms Reading from End of No. 6 Orange to Brown 15 on Water Level Switch (Hot Solenoid - About 900 Ohms) (also checks 1 Amp fuse)
    - Take Ohm Reading from End of No. 3 Blue/Black to Brown 15 on Water Level Switch (Cold Solenoid - About 900 Ohms) (also checks 1 Amp fuse)
- Note:** Reading from No. 6 Orange to No. 3 Blue/Black will Check Both Solenoid Coils (in Series) - About 1800 Ohms.
- Lid - Check Fuse
    - One Amp Fuse - If Open, Change Main Lid Switch
  - Water Level Switch
    - Power Disconnected
    - Terminal 20 to 15 (Machine Empty)

---

## Washer Won't Run - Agitate (MN Models)

- Check Power
- Check Push-Pull Switch in Timer
  - 8B to 37
- Lid Switch
  - UL to 12
- Check Switch
  - 12 to 8B
- Motor Overload Protector
  - Power Disconnected
  - Take Ohms Reading from Black Wire # 37 on Timer connector (black) to white wire # 9 on the same connector (Should Show About 0.0 Ohms)
- Timer
  - 18 to 16
  - Can be checked from 18 Red on Selector Switch to 16 Yellow on Water Level Switch
  - 14 to 16
  - Can be Checked from 14 Brown on Selector Switch to 16 Yellow on Water Level Switch
- Water Level Control
  - 20 to 16 (Washer Full)
- Motor Just Hums
  - Check Timer Reversing Contacts
  - 21 to 32
  - 22 to 9
- Won't Agitate through Full Wash Cycle
- Check Selector Switch
  - Delicates & Knits & Woolens are Interrupted Cycles
  - 14 to 18 (Except Delicates & Knits & Woolens)

---

## Washer Won't Run - Agitate (CS & DA Models)

- Check Power
- Check Lid Switch
  - UL to 12
- Check Switch
  - 12 to 8B
- Timer
  - 8B to 37
- Motor Overload
  - (Can be Checked from Black wire # 37 on timer connector (black) to White wire # 9 on same connector)
- Timer
  - 18 to 16
  - (Can be Checked from 18 Red on Selector Switch to 16 Yellow on Water Level Switch)
  - 14 to 16
  - (Can be Checked from 14 Brown on Selector Switch to 16 Yellow on Water Level Switch)
- Water Level Switch
  - 20 to 16 (Machine Full)
- Motor Just Hums
  - Check Timer Reversing Contacts
  - 21 to 32
  - 22 to 9
- Won't Agitate through Full Wash Cycle
  - Check Selector Switch
  - Delicates & Knits & Woolens are Interrupted Cycles
- Selector Switch
  - 14 to 18 (Except Delicates & Knits & Woolens)

---

## Washer Won't Spin (MN, CS, and DA Models)

First Determine if Motor will Run in Wash (see Washer Won't Run - Agitate).

Get Washer Running in Agitate

- Disconnect from Power
- Locate Blue 21 and Yellow 22 Wires at Motor Centrifugal Switch and Reverse their Positions
- Reconnect to Power. If Washer then Spins, You Do Not Have Motor or Drive Mechanism Problems. Replace timer.

### TIMER SET IN:

WASH/RINSE	21 to 32 Contacts Closed	22 to 9 Contacts Closed
SPIN	21 to 9 Contacts Closed	22 to 32 Contacts Closed

- If Washer Still Will Not Spin:
  - Look for Clothing Article Under Washbasket in Outer Tub
  - Check Drive Pulley for Restriction
  - Check Transmission Unit

# DA TROUBLESHOOTING

## FLOW CHART INDEX

SYMPTOM	PAGE
Washer is Dead (With MEQ)	4-10
Washer is Dead (No MEQ)	4-11
Add Coins Light Always On (With MEQ)	4-12
Add Coins Light Always On (No MEQ)	4-13
In Use Light Always On	4-14
Add Coins Light Doesn't Come On Between Cycles (With MEQ)	4-15
Add Coins Light Doesn't Come On Between Cycles (No MEQ)	4-18
Washer Won't Fill	4-19
Washer Won't Agitate	4-21
Washer Won't Spin Out	4-22
Washer Stops in Final Rinse	4-23
Washer Does Not Stop Between Cycles	4-24
MEQ Will Not Communicate Properly	4-25
Trouble Cycle Indicated	4-27
No-Run Cycle Indicated	4-28
Failure Code Indicated	4-29

The following flow charts were developed to guide you through troubleshooting the control system with the use of the MEQ hand-held computer.

There are three types of information boxes used within the flow charts to guide you through the checks. They are:

**TV Screen:** *Information only:* This box tells you the characteristics of the unit - how it behaves.

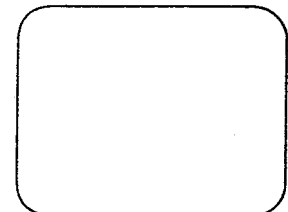

**Note:** *Reminder:* This box serves as a reminder - usually reminding you that data can be lost by performing the step. If possible, probe the unit before service is started to collect memory information.

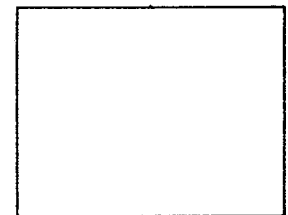

**Box:** *Step to be Performed:* This box contains information on the step to be performed. Direction arrows guide the flow of steps depending on the results of the previous step.



# Washer is Dead (With MEQ)

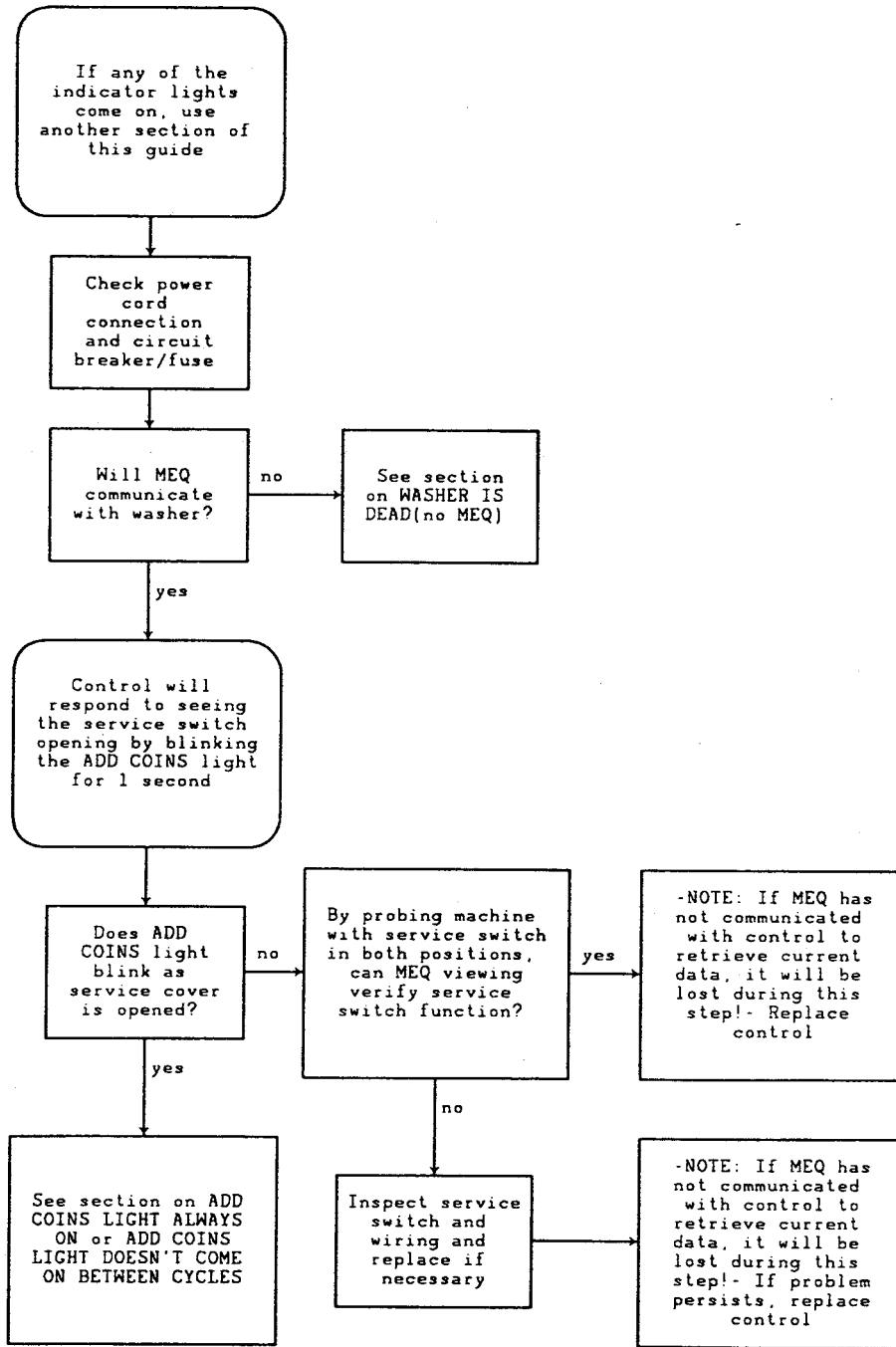

# Washer is Dead (No MEQ)

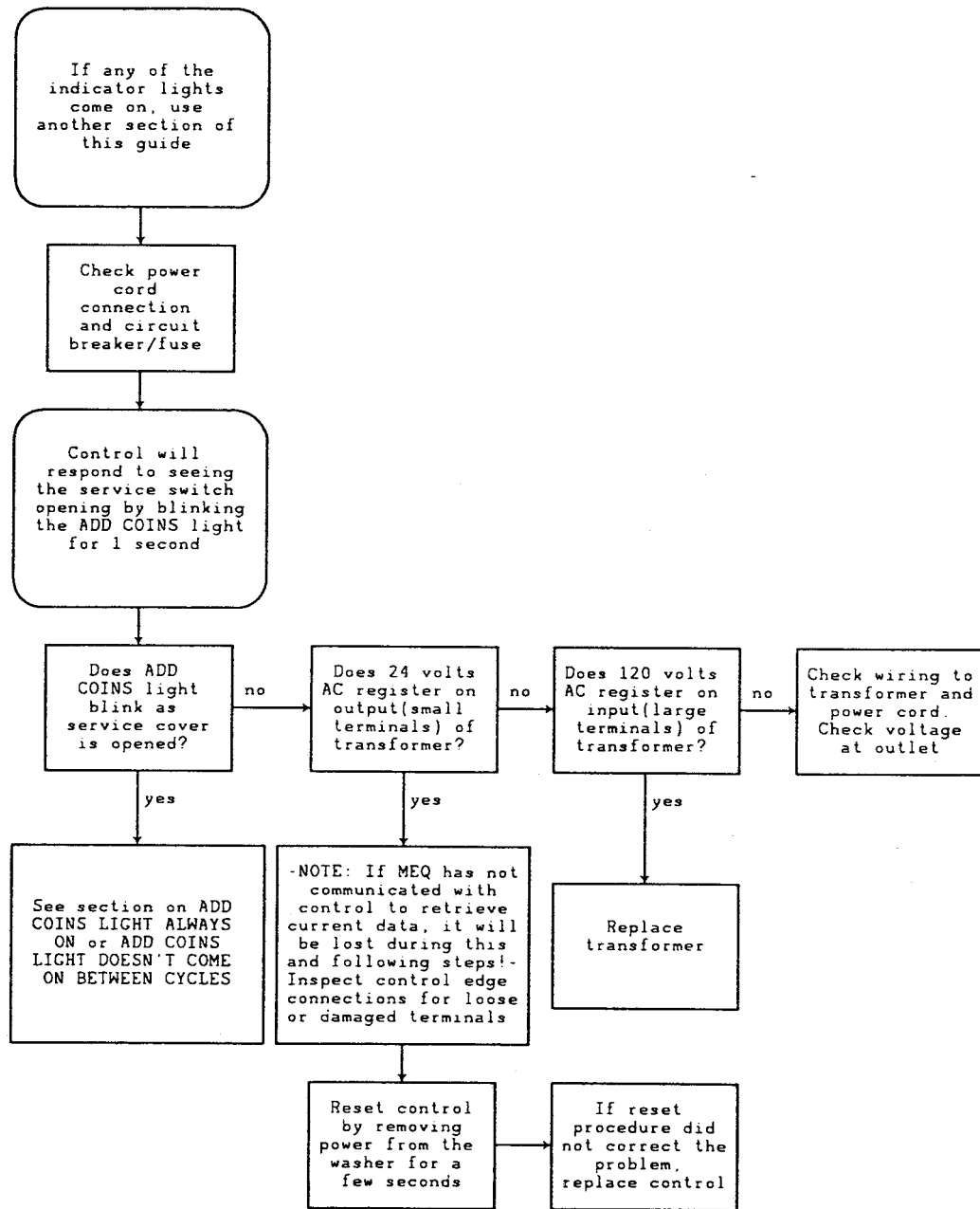

# Add Coins Light Always On (With MEQ)

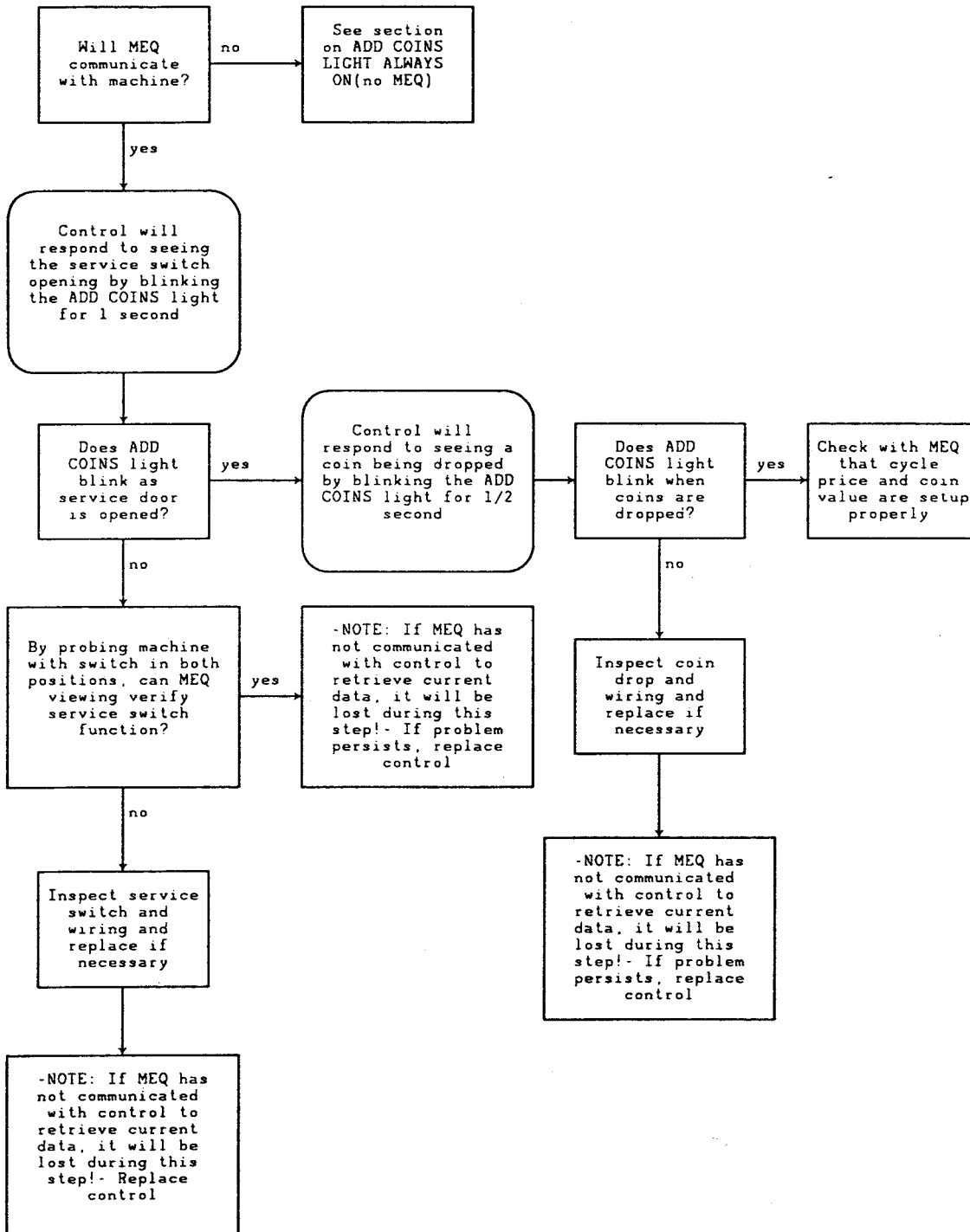



## Add Coins Light Always On (No MEQ)

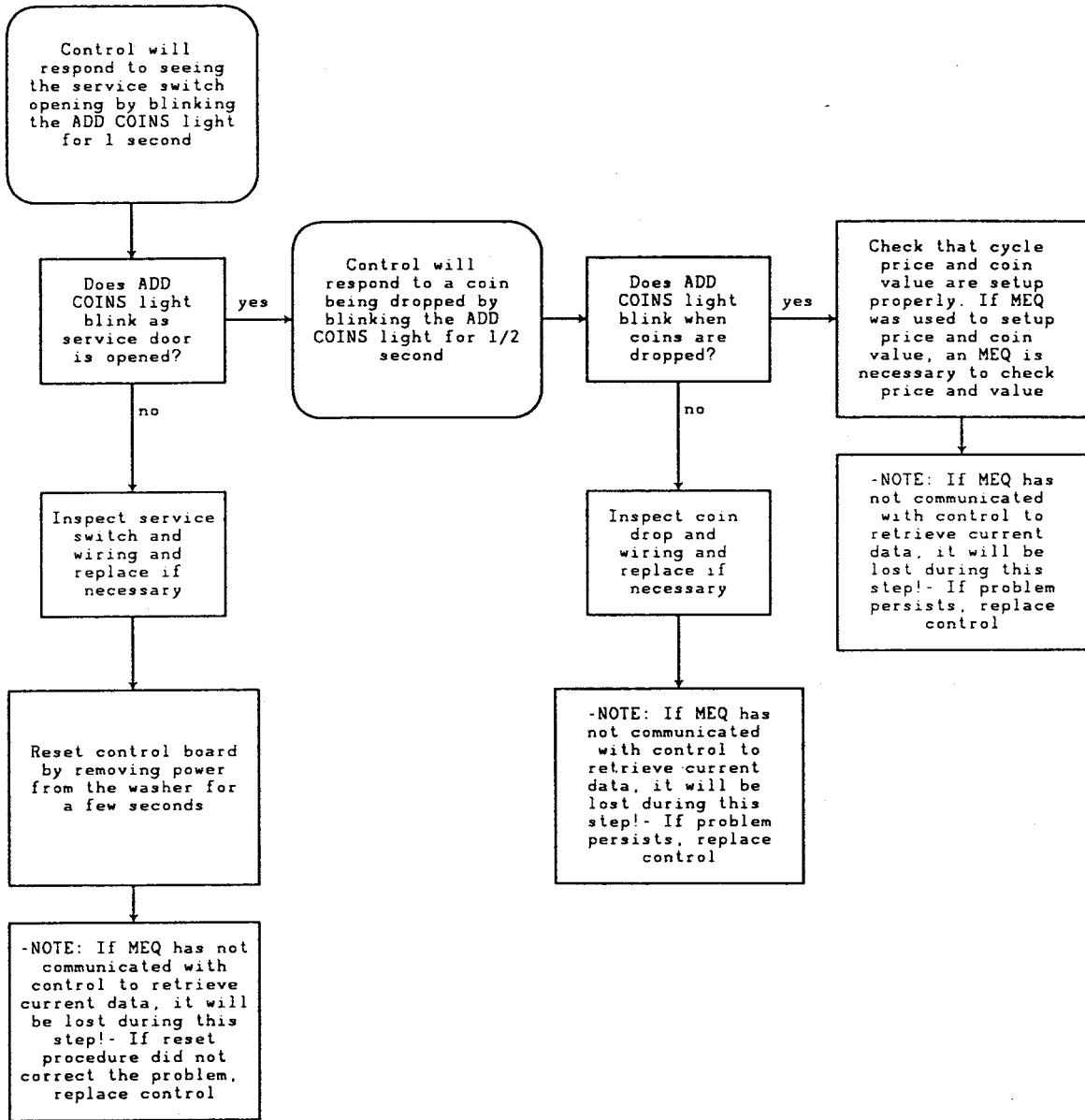

**In Use Light Always On**

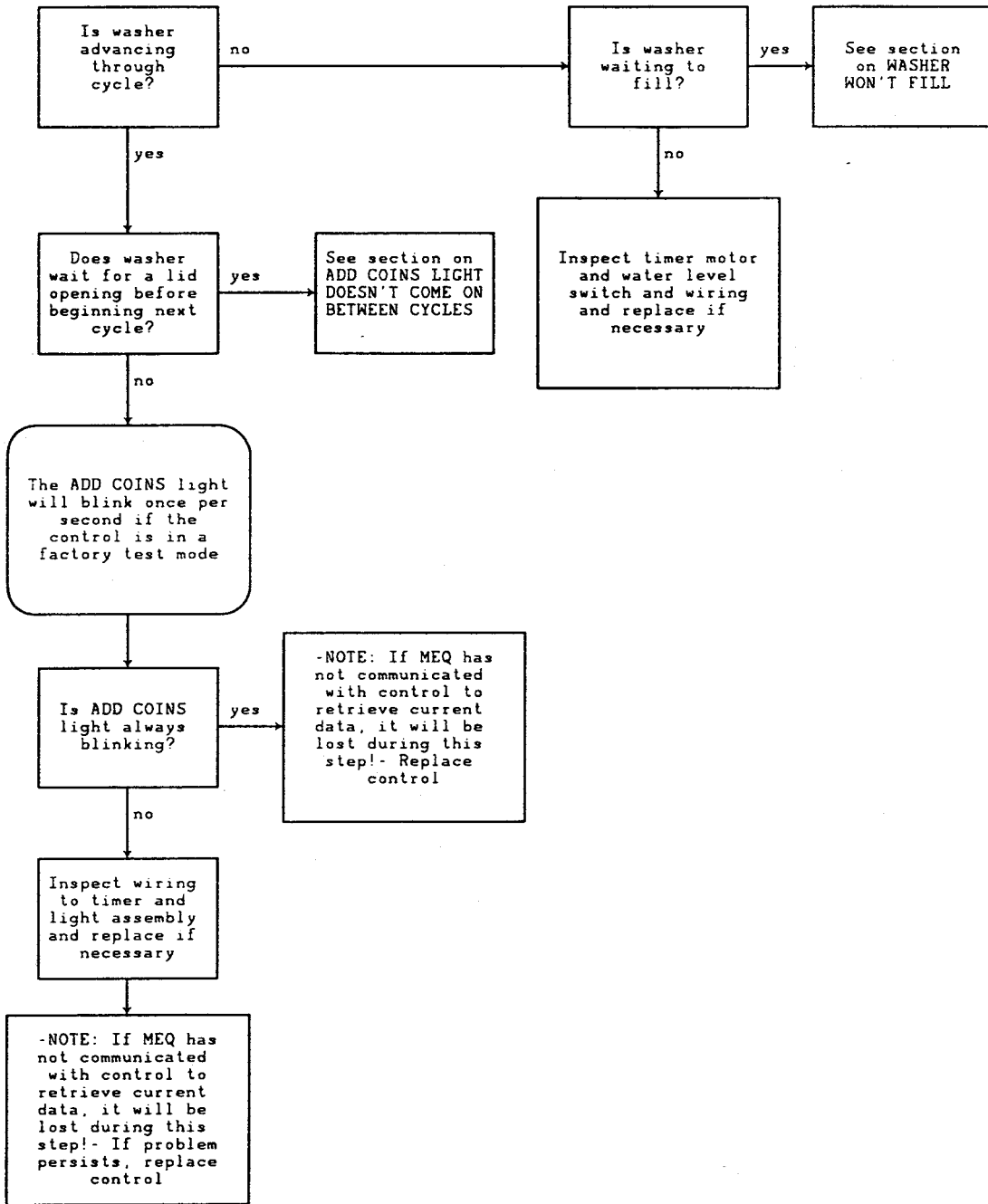

## Add Coins Light Doesn't Come On Between Cycles (With MEQ)

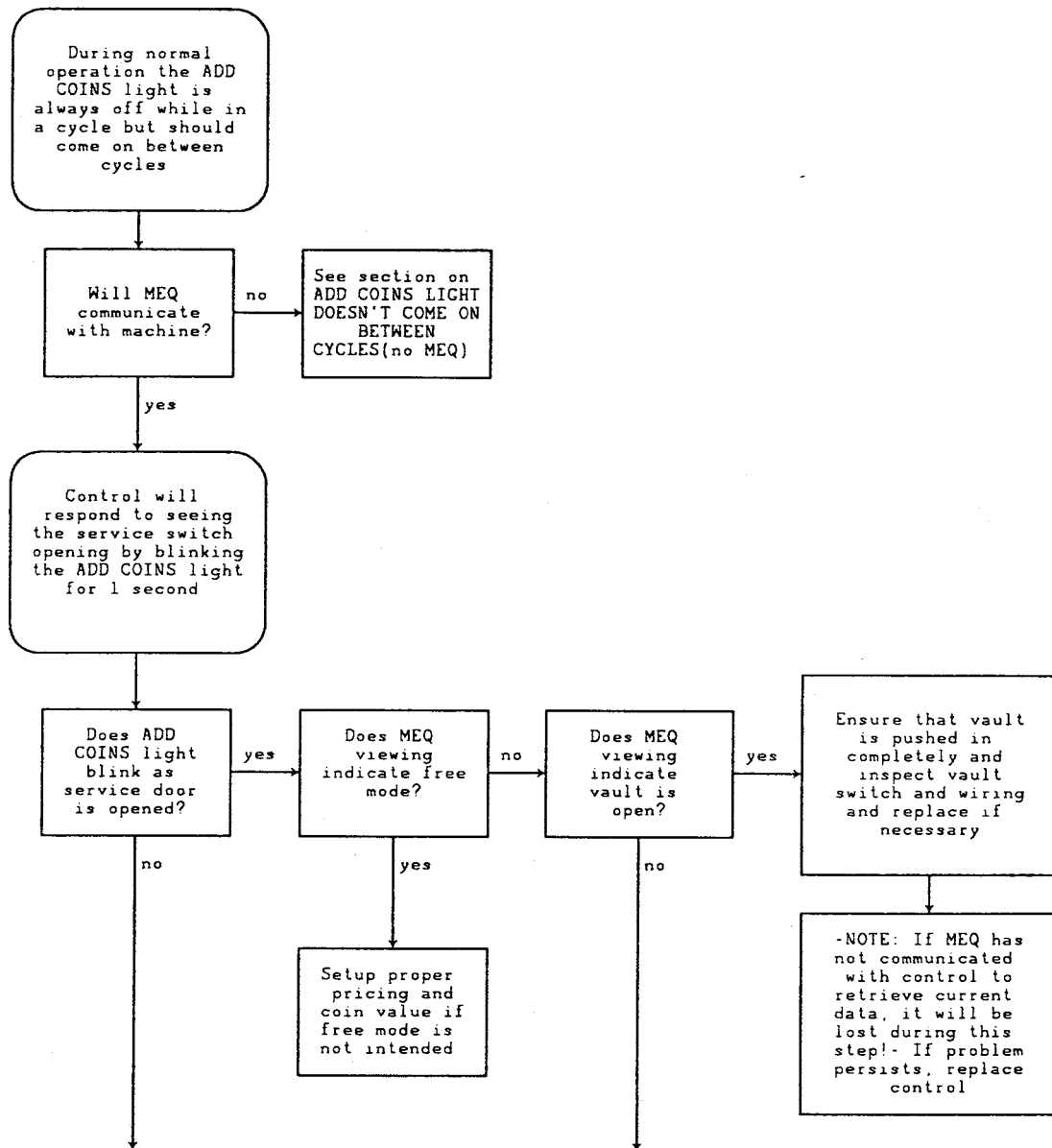

# Add Coins Light Doesn't Come On Between Cycles (With MEQ) (Continued)

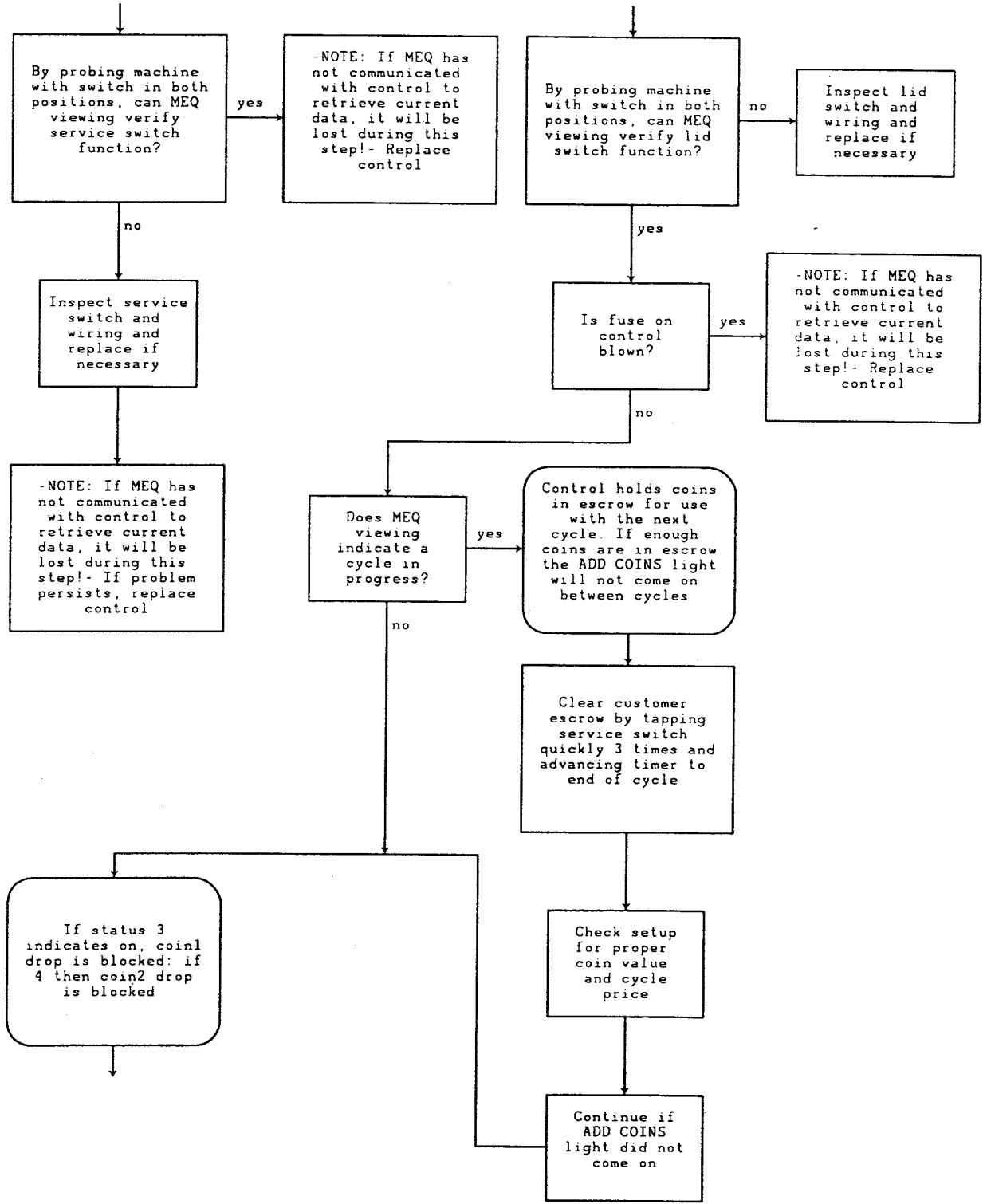

## Add Coins Light Doesn't Come On Between Cycles (With MEQ) (Continued)

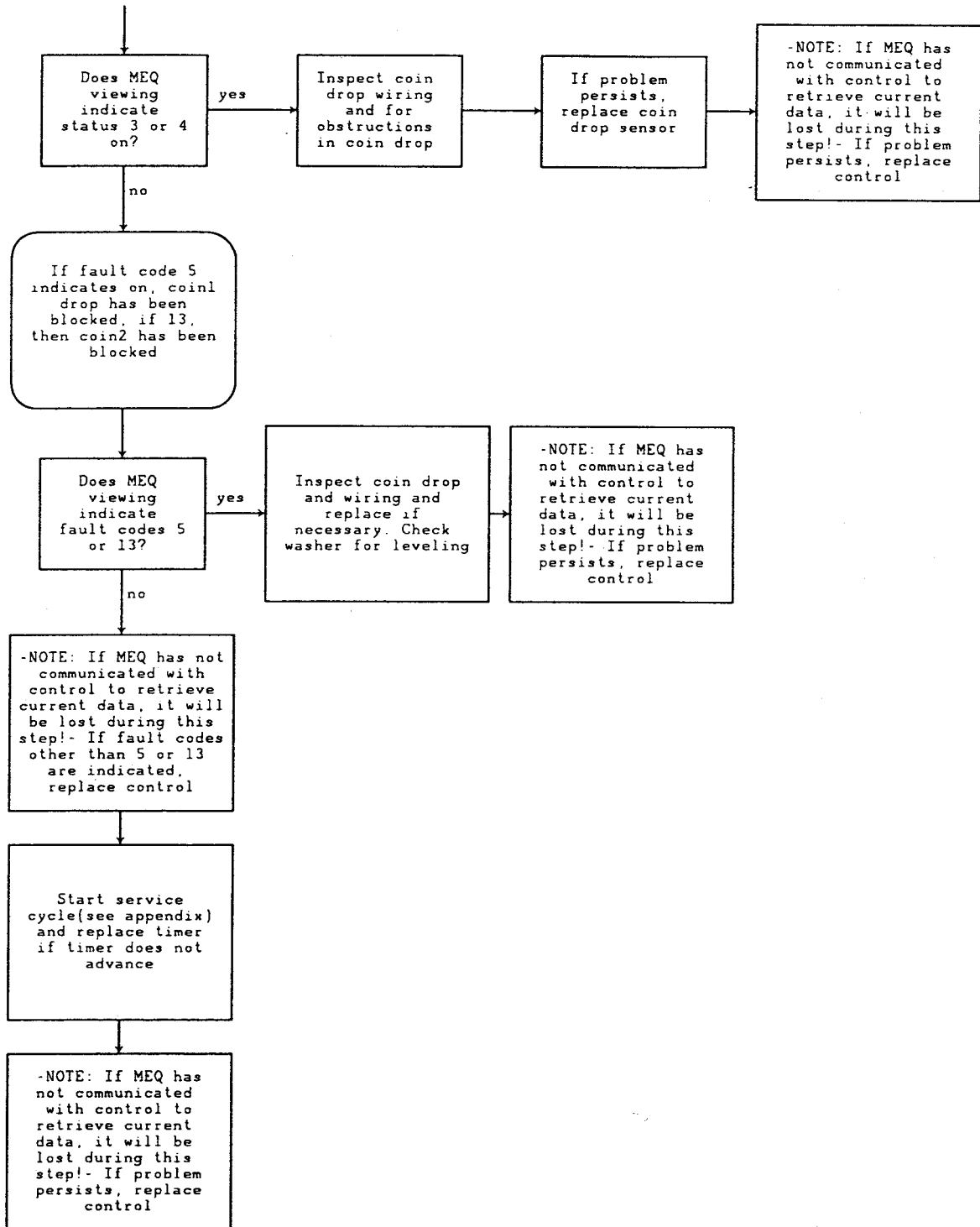

# Add Coins Light Doesn't Come On Between Cycles (No MEQ)

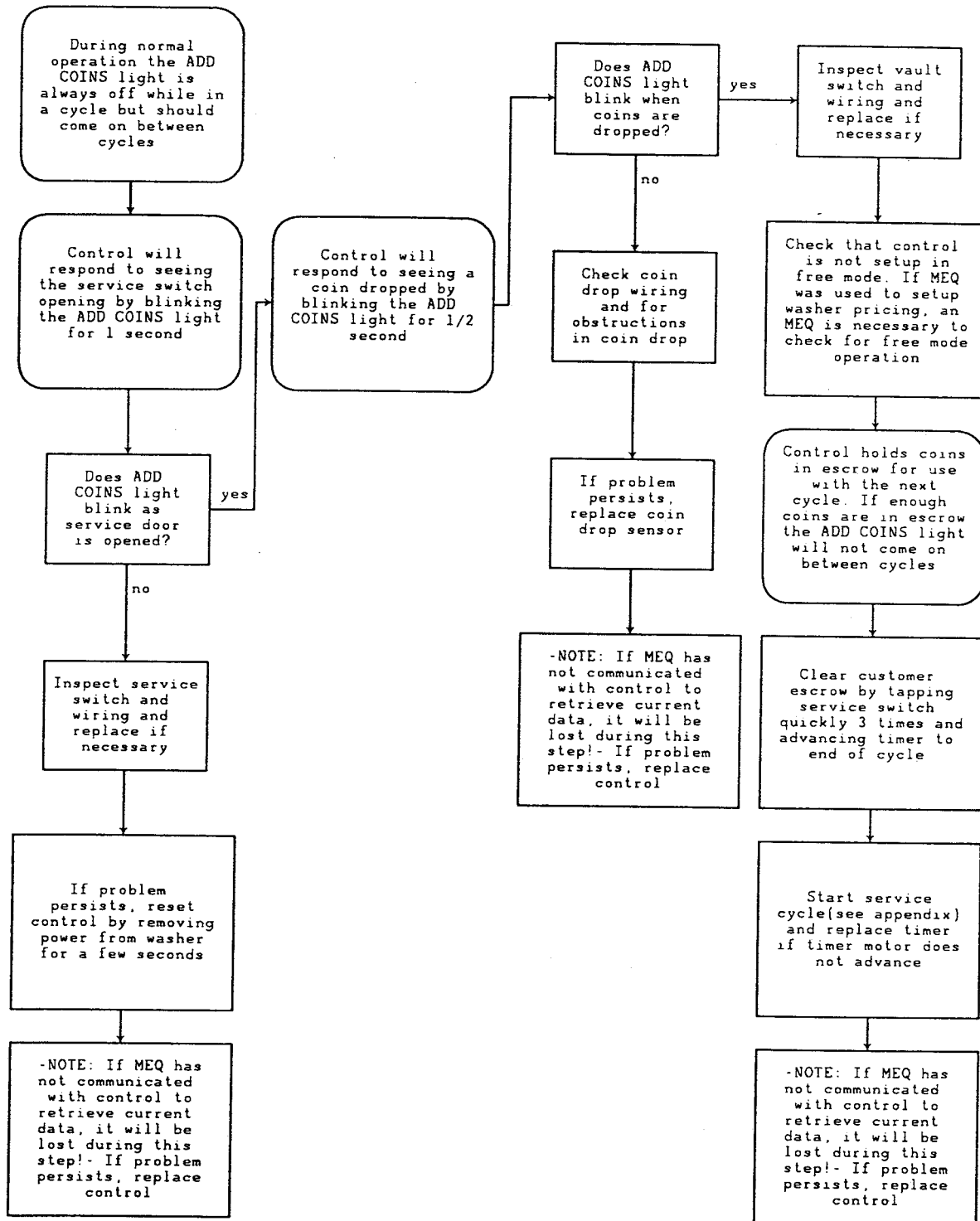

# Washer Won't Fill

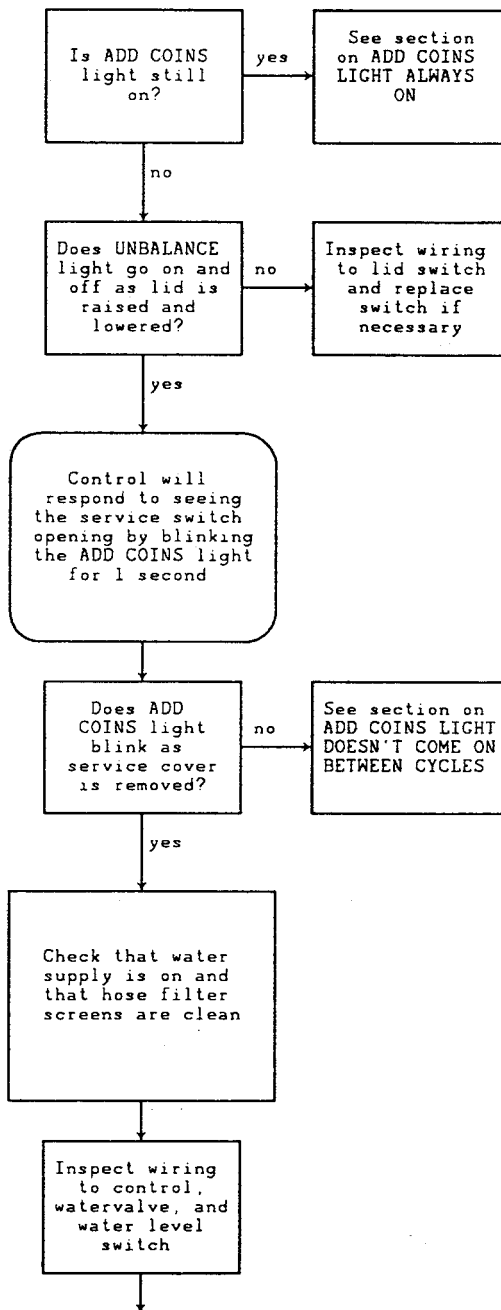

## Washer Won't Fill (Continued)

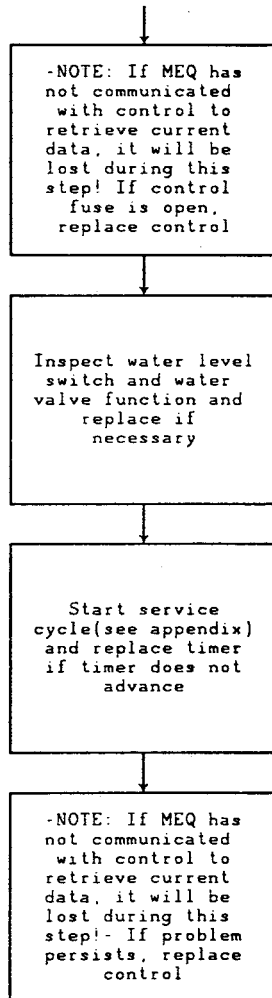



# Washer Won't Agitate

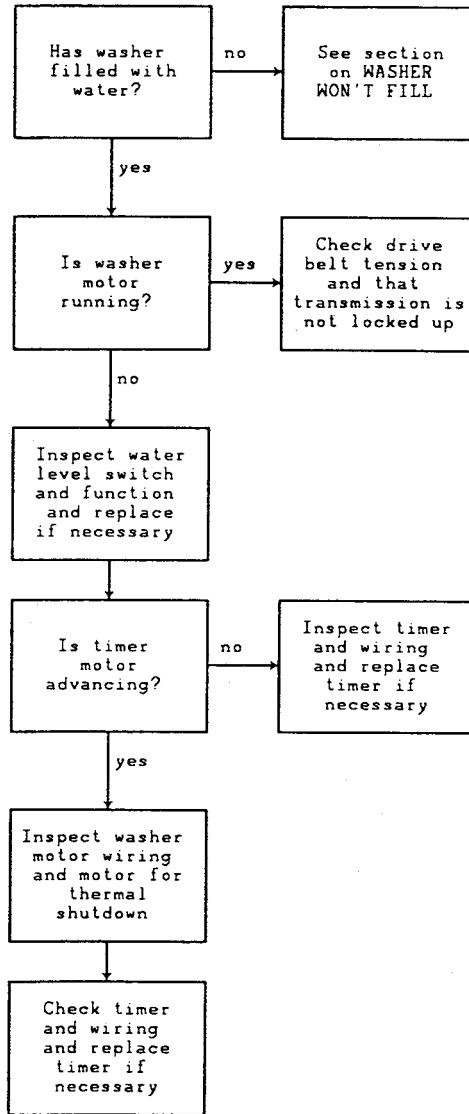

# Washer Won't Spin Out

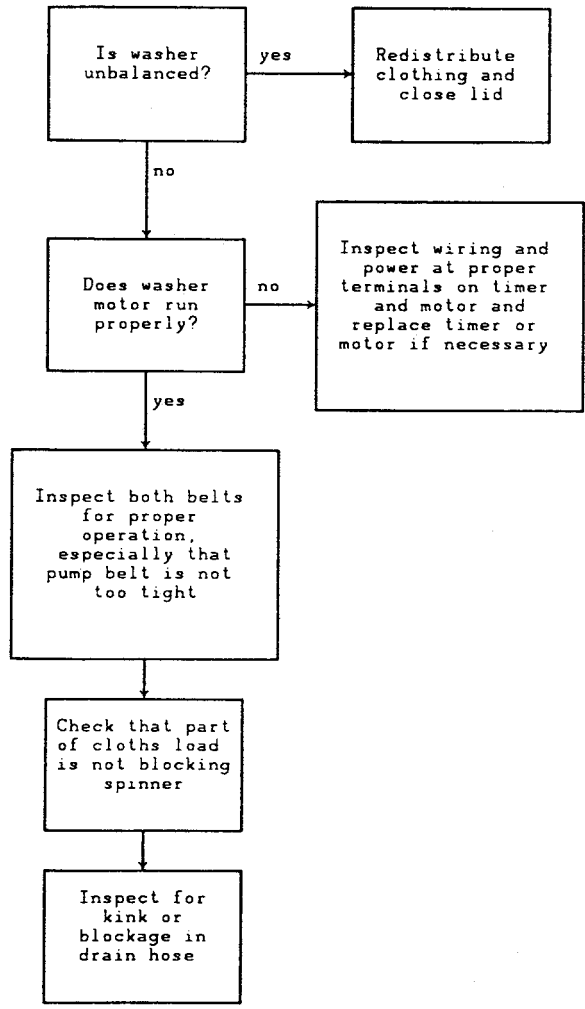

## Washer Stops in Final Rinse

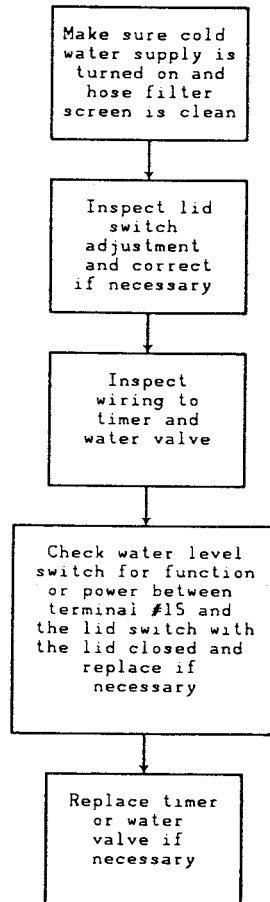

# Washer Does Not Stop Between Cycles

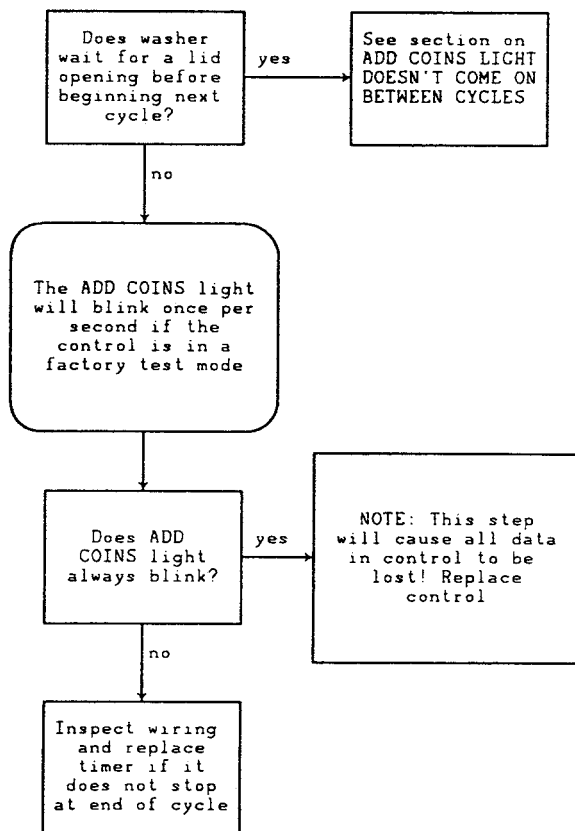

## MEQ Will Not Communicate Properly

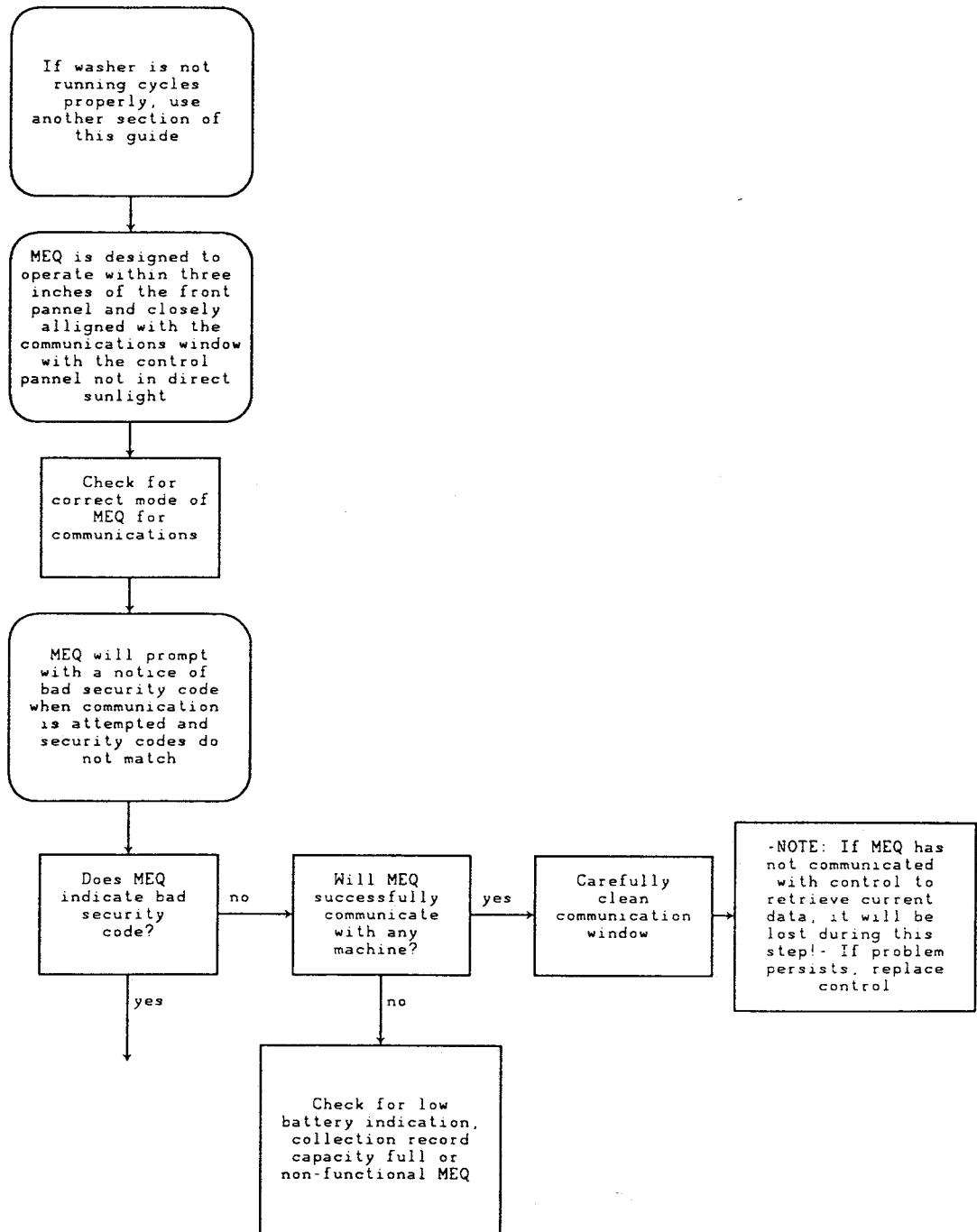

# MEQ Will Not Communicate Properly (Continued)

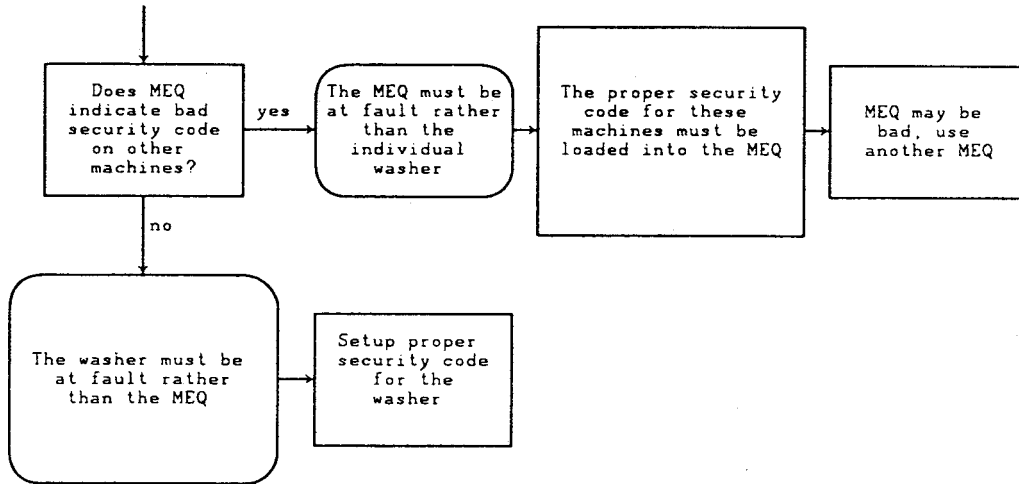

## Trouble Cycle Indicated

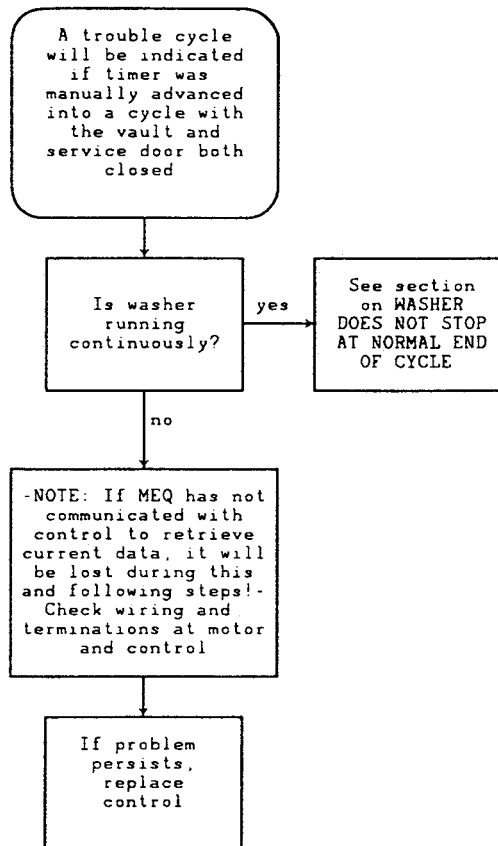

# No-Run Cycle Indicated

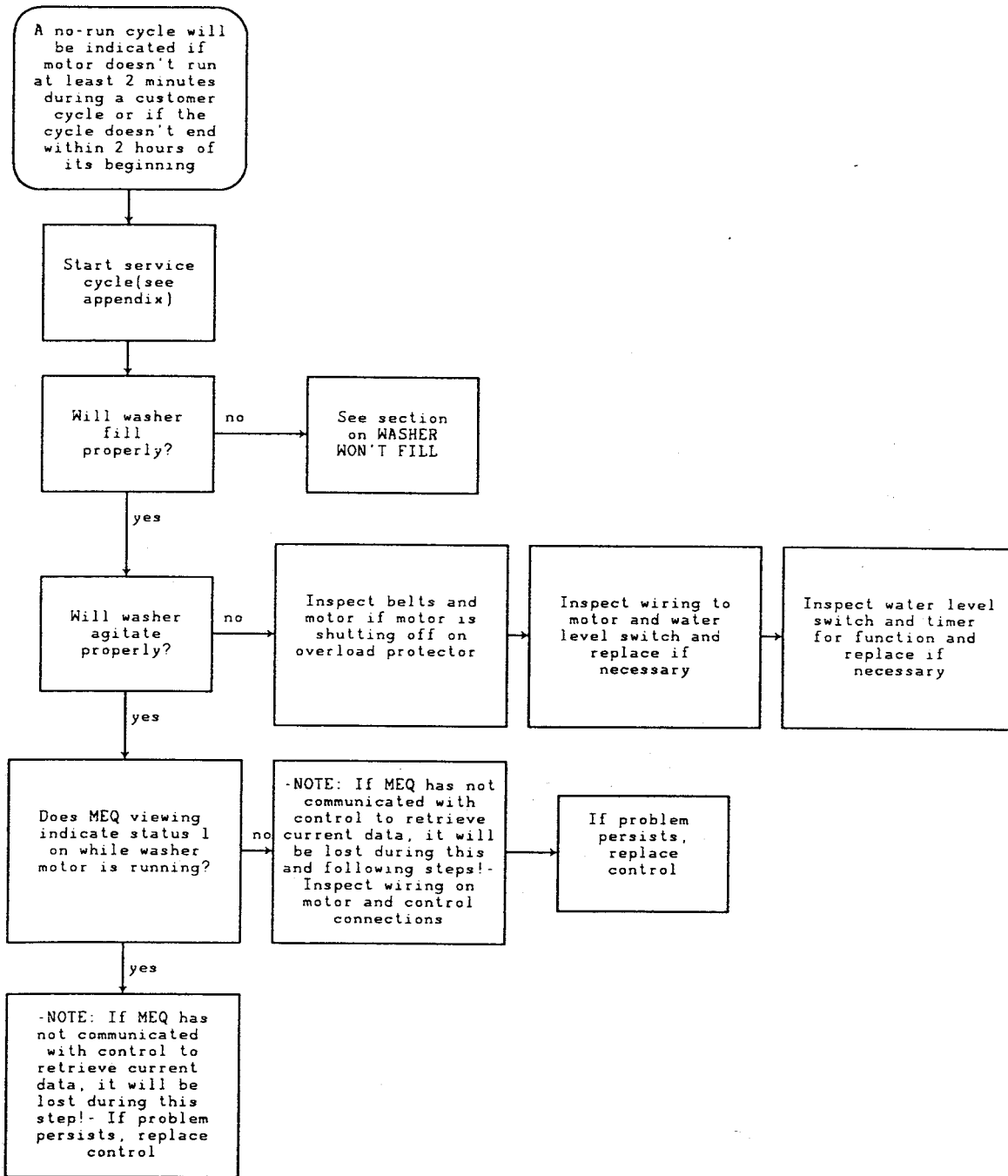



# Failure Code Indicated

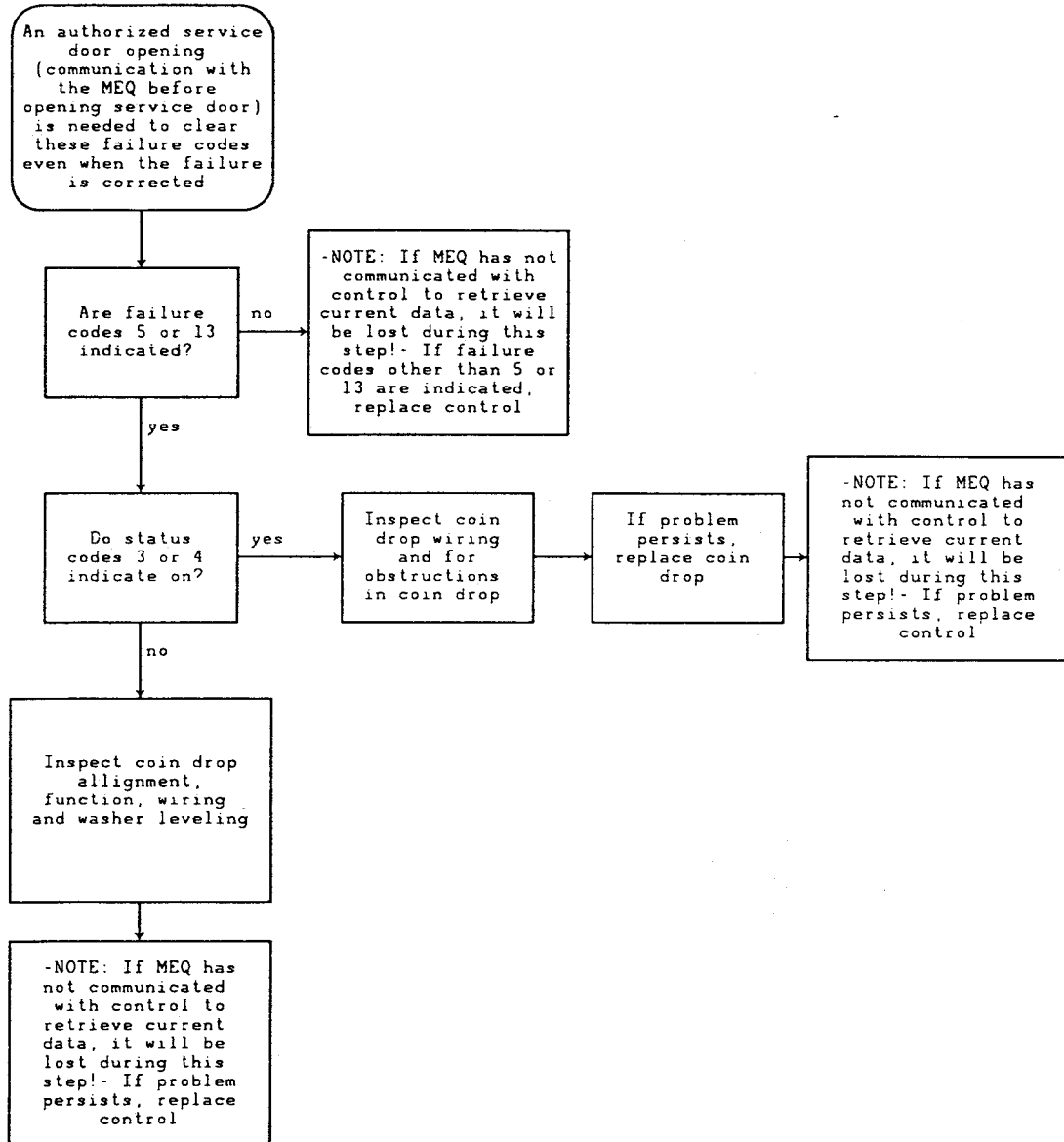

## PD TROUBLESHOOTING

### FLOW CHART INDEX

SYMPTOM	PAGE
Display is blank	4-31
Abnormal display or function	4-31
Washer stuck with 0 minutes remaining in display	4-32
Control does not respond to program key inputs	4-32
Will not respond to MEQ	4-33
No response to Coin1	4-33
No response to Coin2	4-34
Will not keep time of day during power interruptions	4-34
"Unbalance" stays in display	4-35
Cannot enter or exit operator mode	4-35
Operator options revert to defaults	4-35
Display flashes in user mode	4-35
Water runs without program selected	4-36
No hot water or no cold water	4-36
Spins instead of agitating	4-36
No spin or no agitate	4-36
<b>PD WASHER DIAGNOSTIC PROGRAM</b>	<b>4-37</b>
<b>PD WASHER FAILURE CODE GUIDE</b>	<b>4-40</b>

**CAUTION:** Unplug washer anytime control panel is open unless measuring voltages.

**NOTE:** When measuring DC voltages the common terminal of the voltmeter should be connected to a control board mounting nut near the edge of the board.

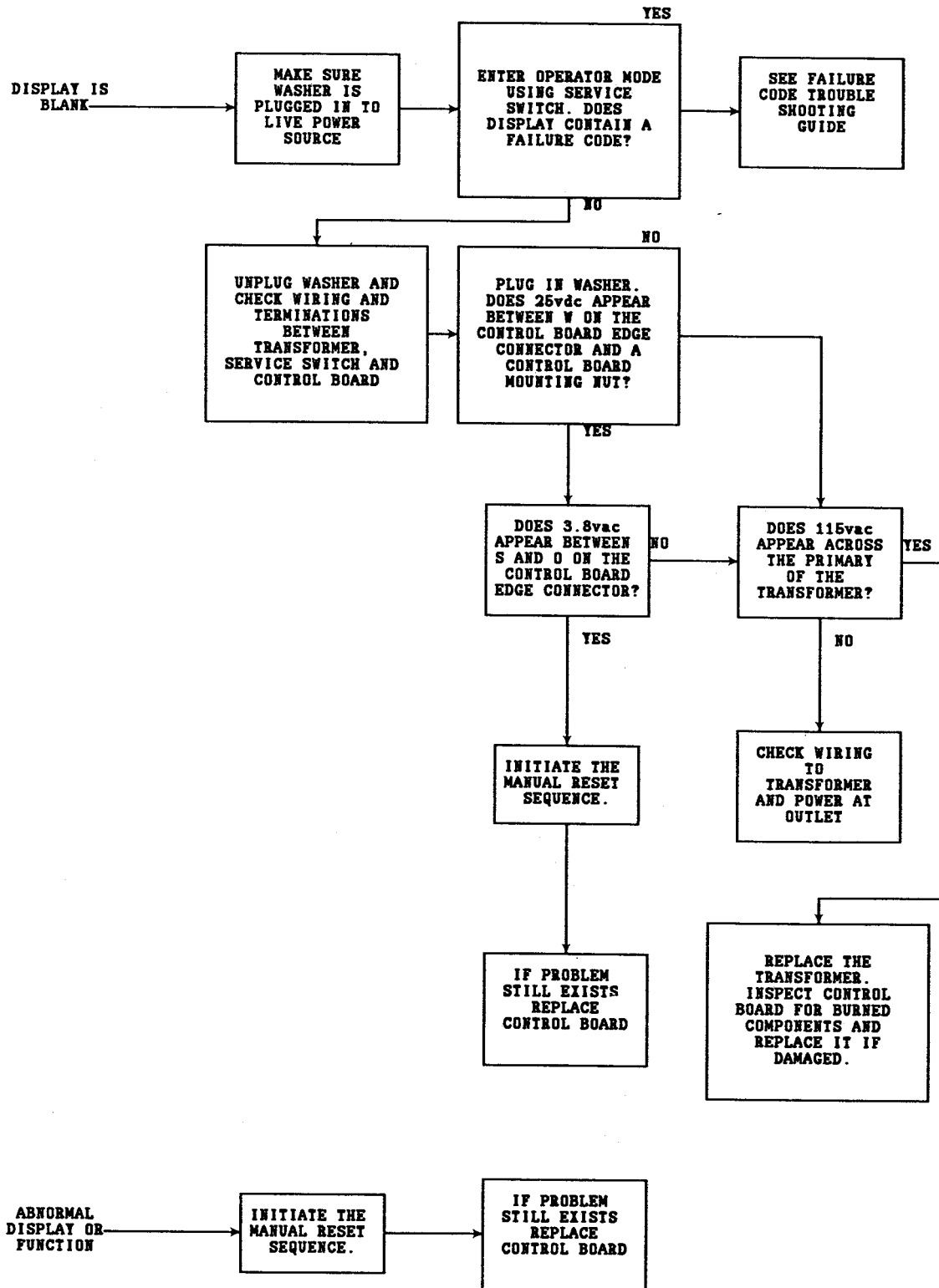

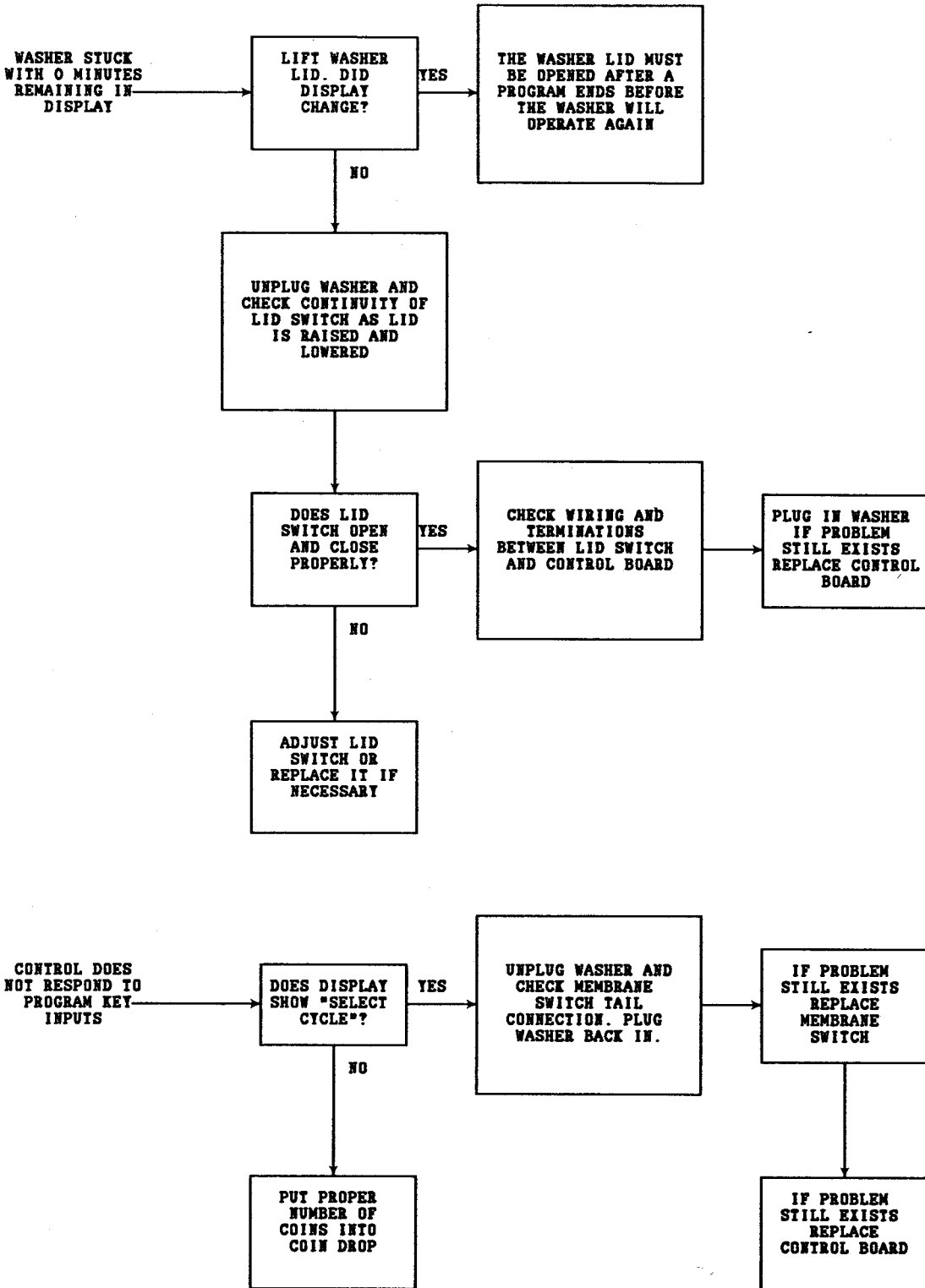

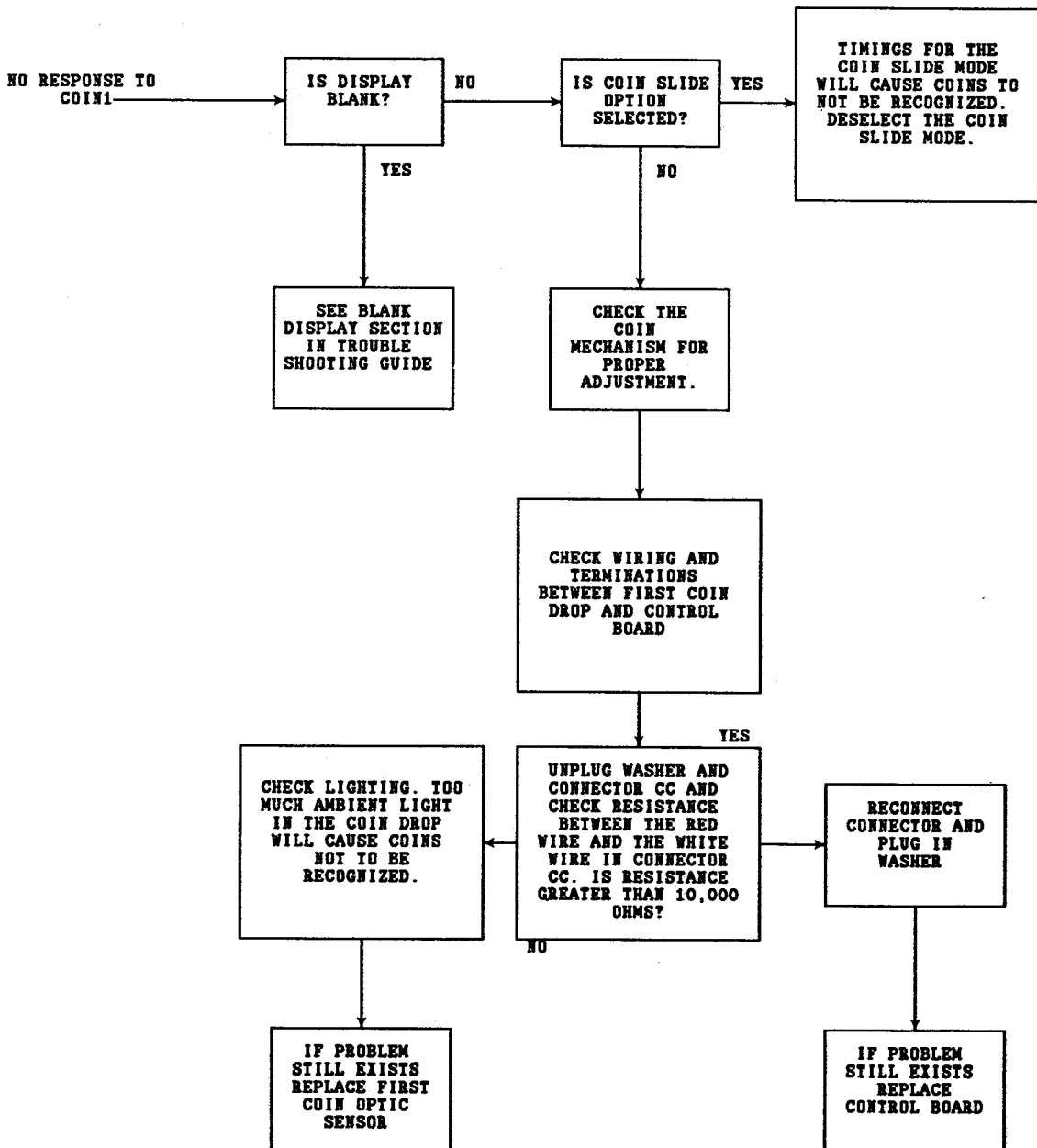
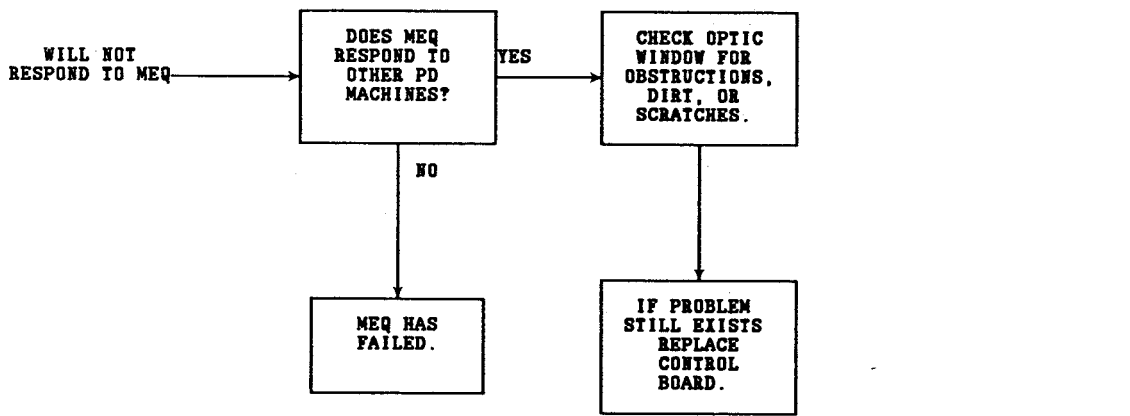

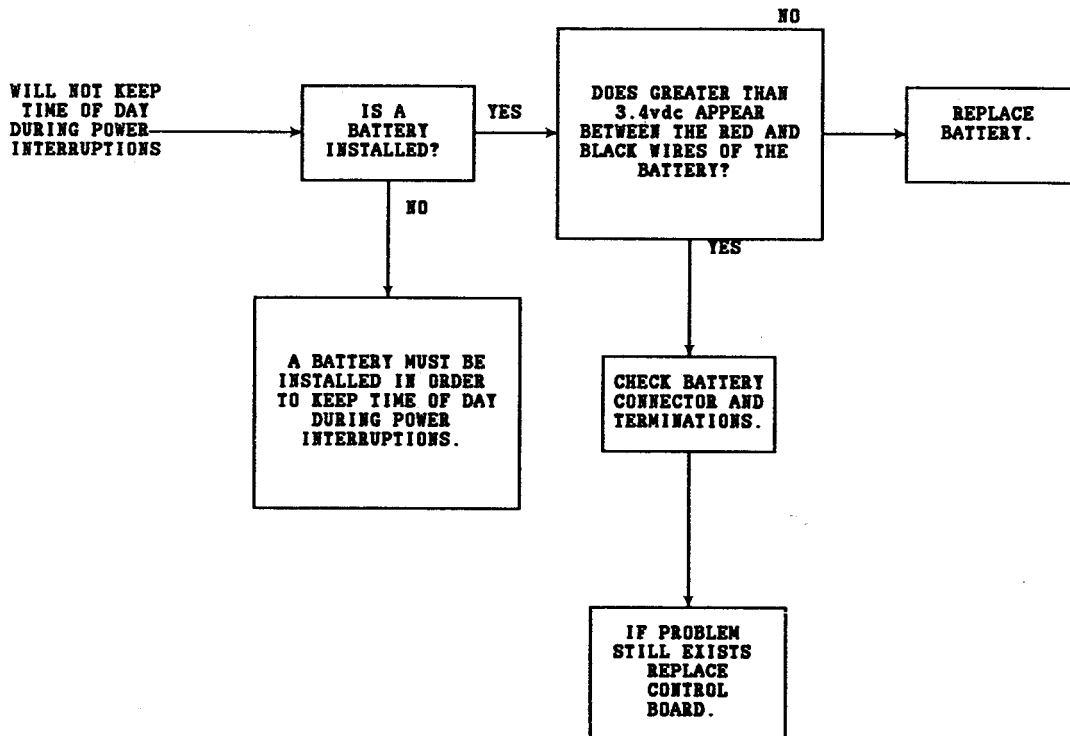
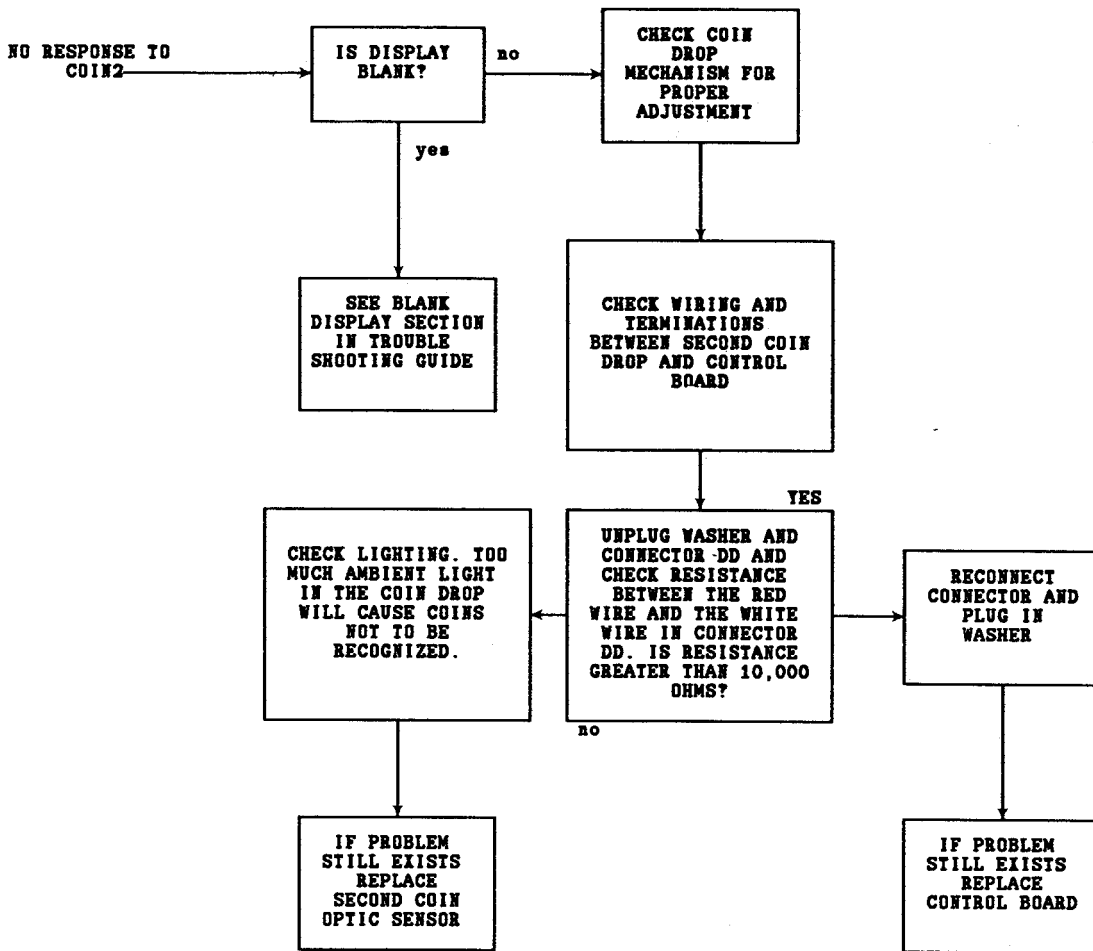

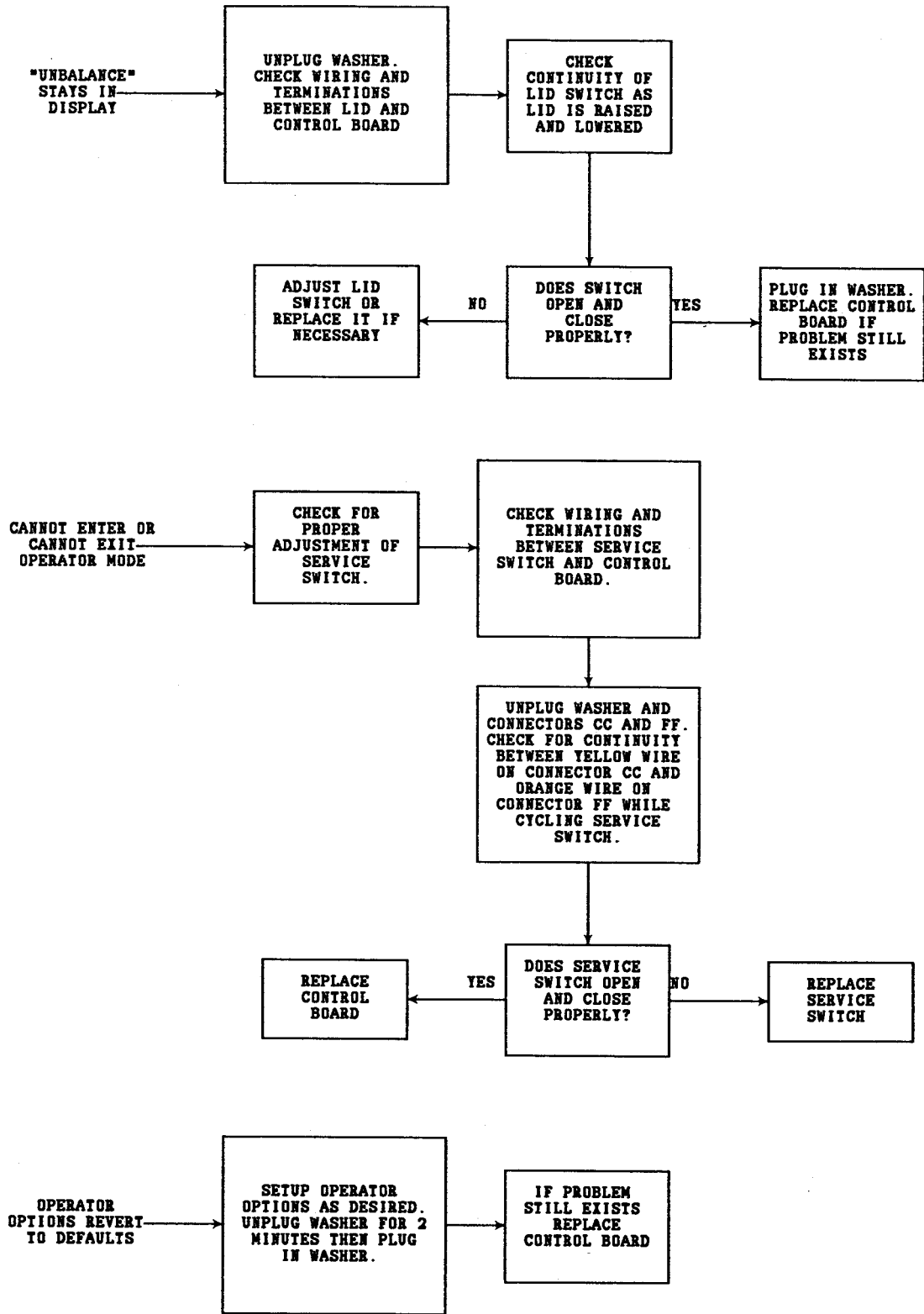

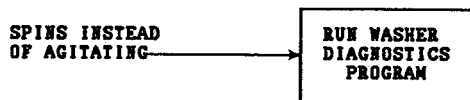
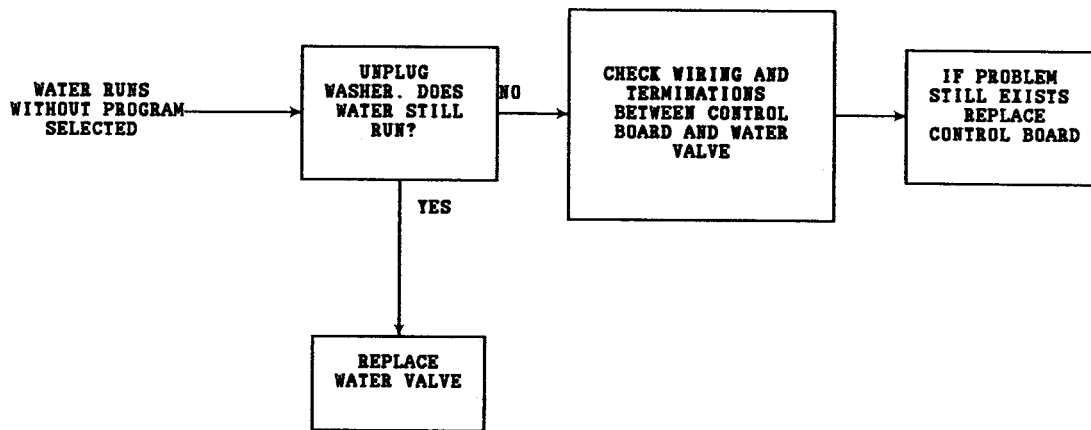
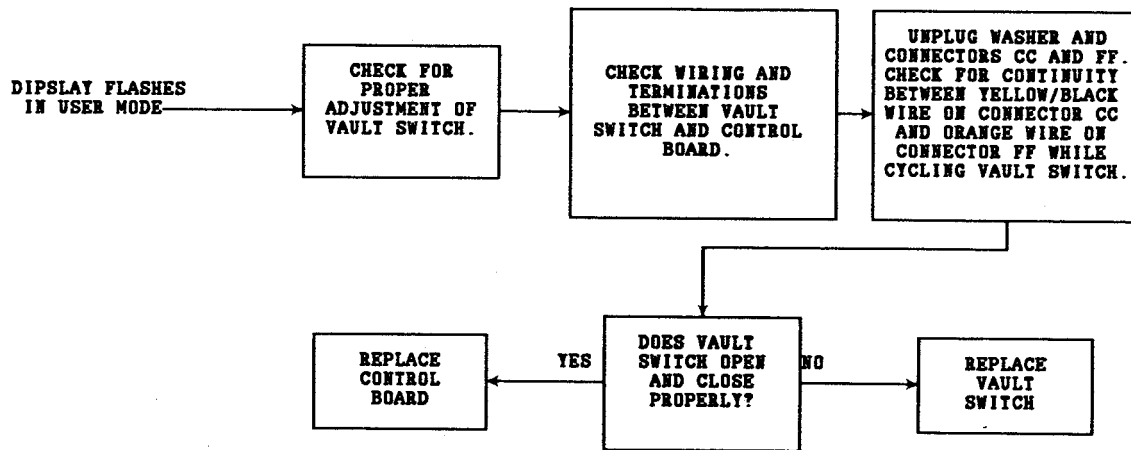



PD WASHER DIAGNOSTIC PROGRAM

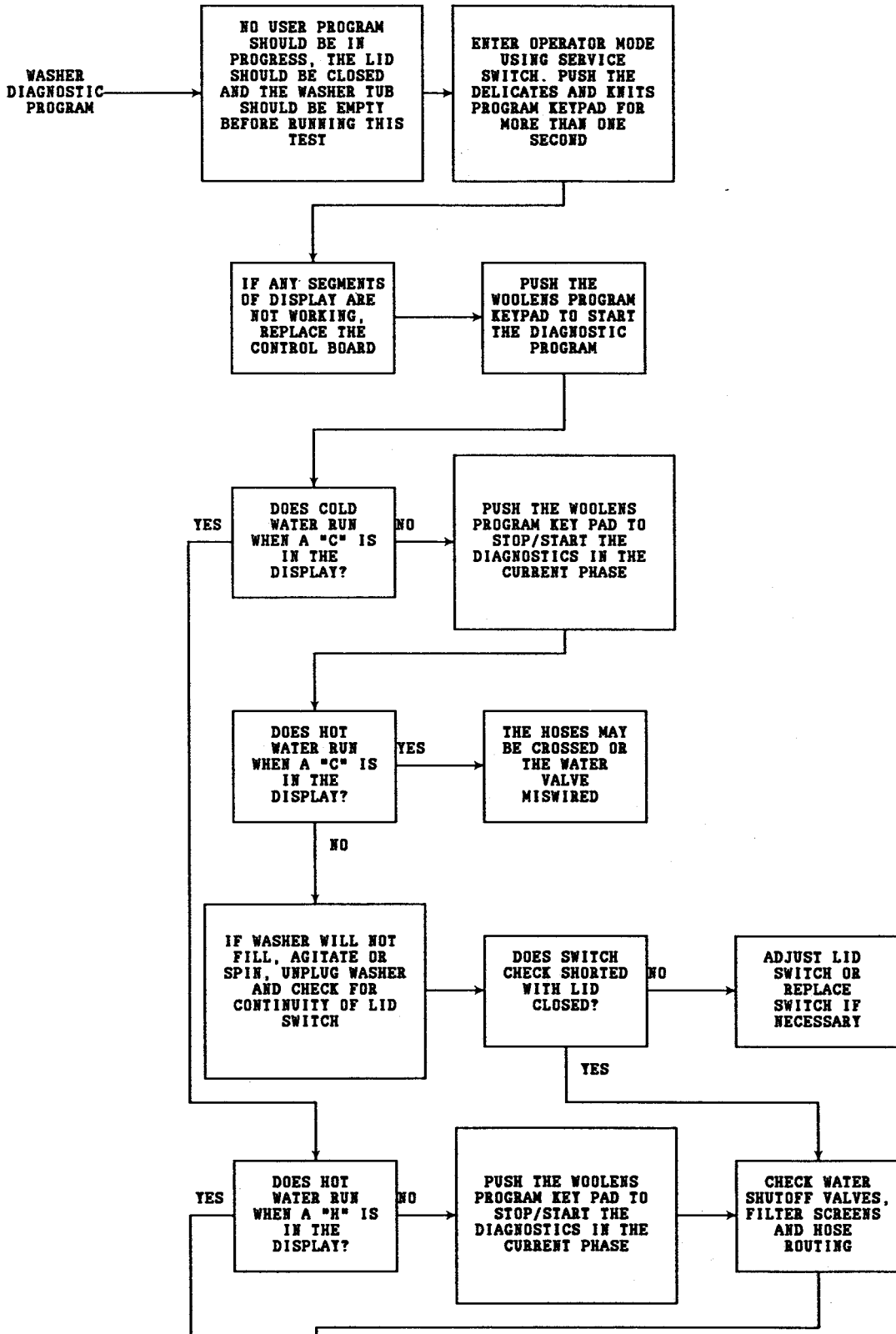

PD Washer Diagnostic Program (Continued)

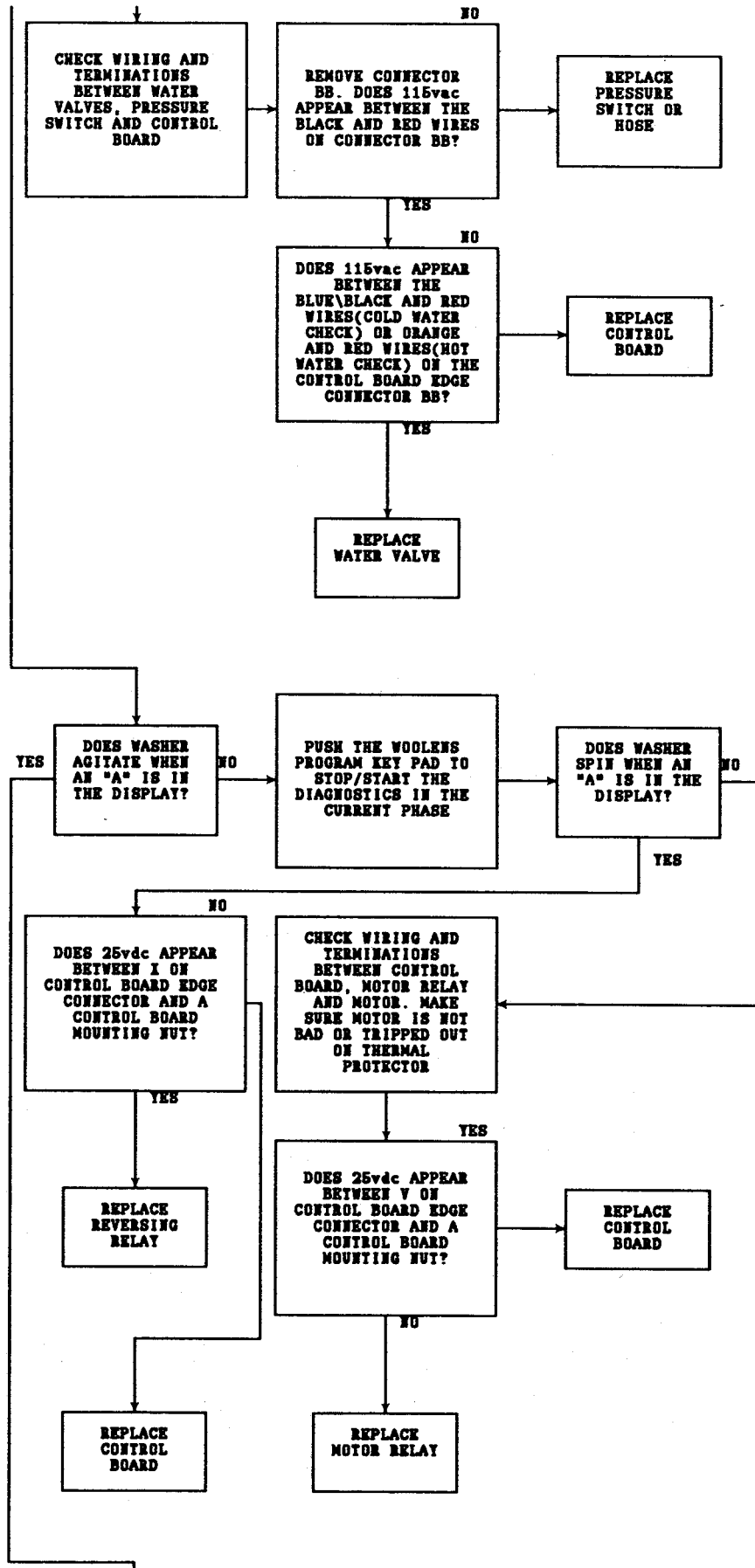

# PD Washer Diagnostic Program (Continued)

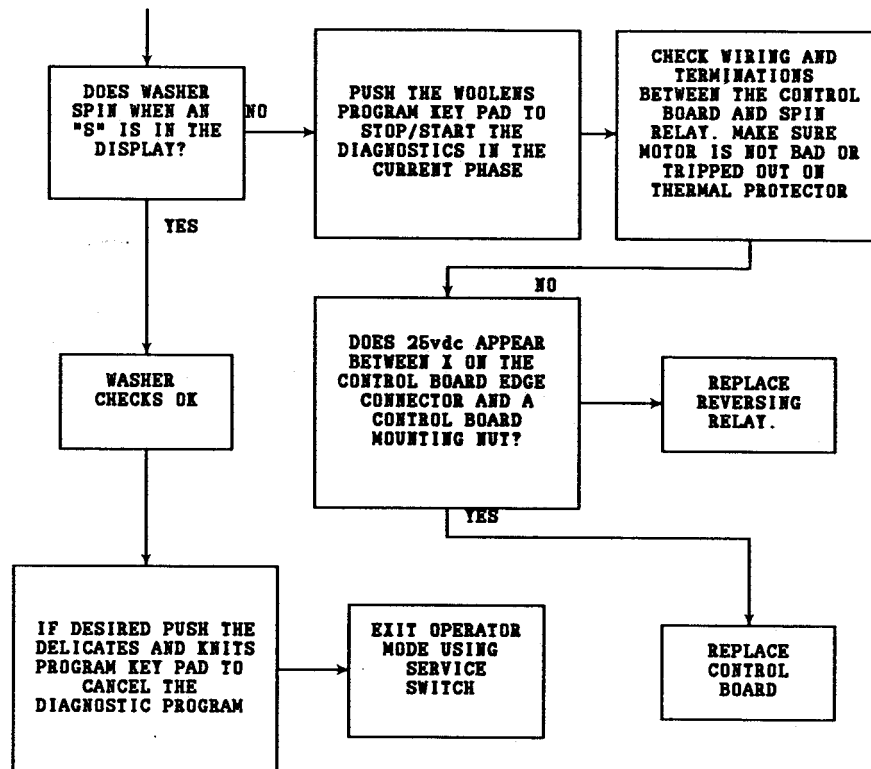

**PD WASHER FAILURE CODE GUIDE**

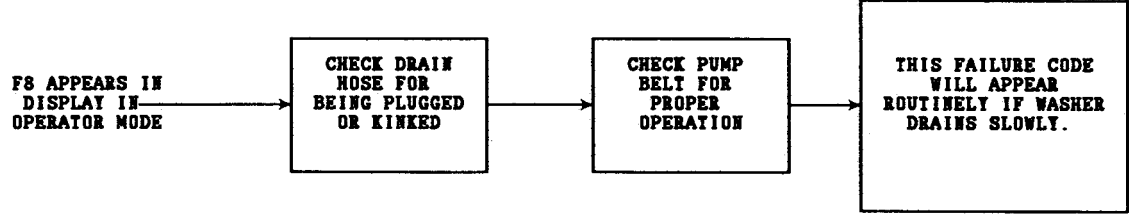
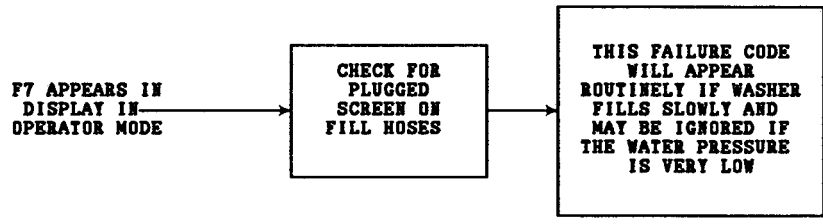
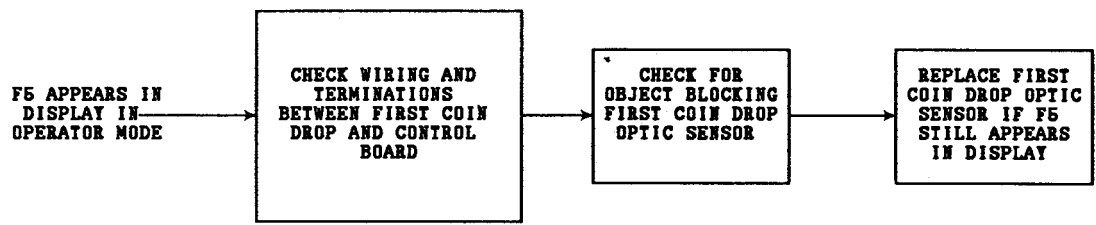
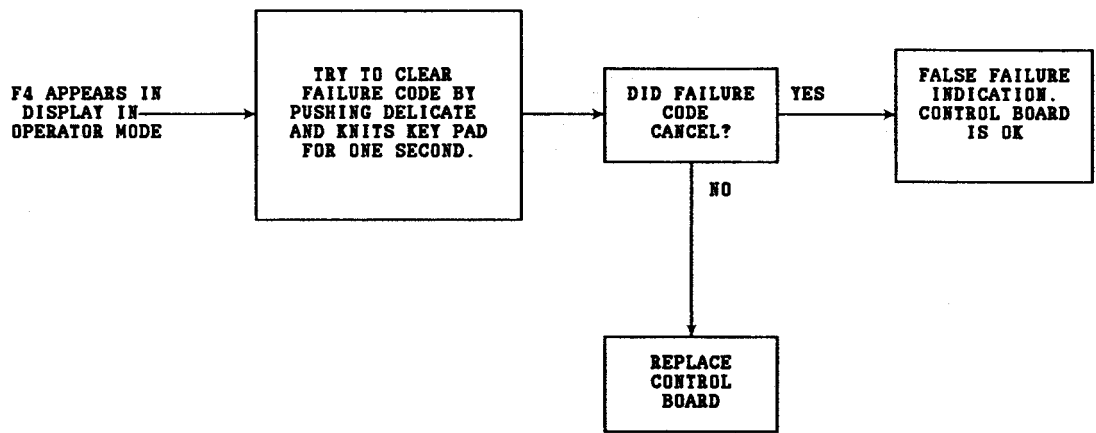
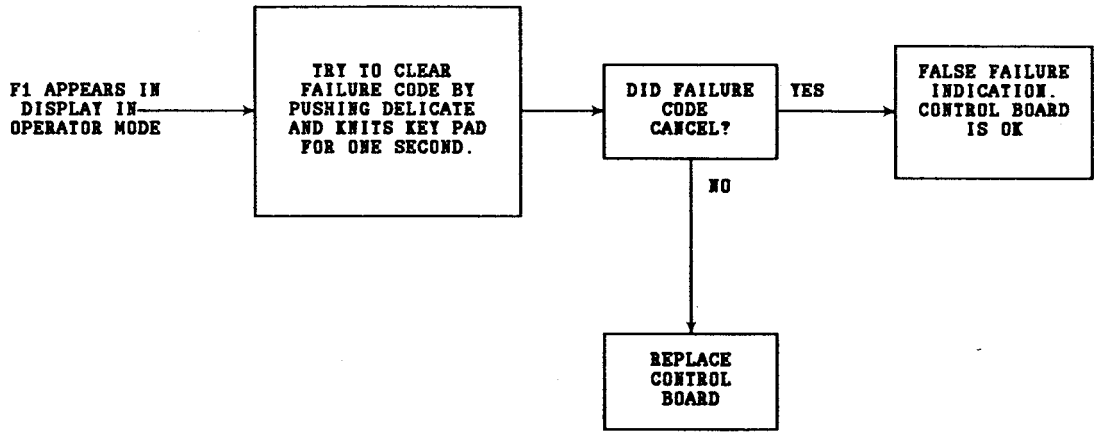

PD Washer Failure Code Guide (Continued)

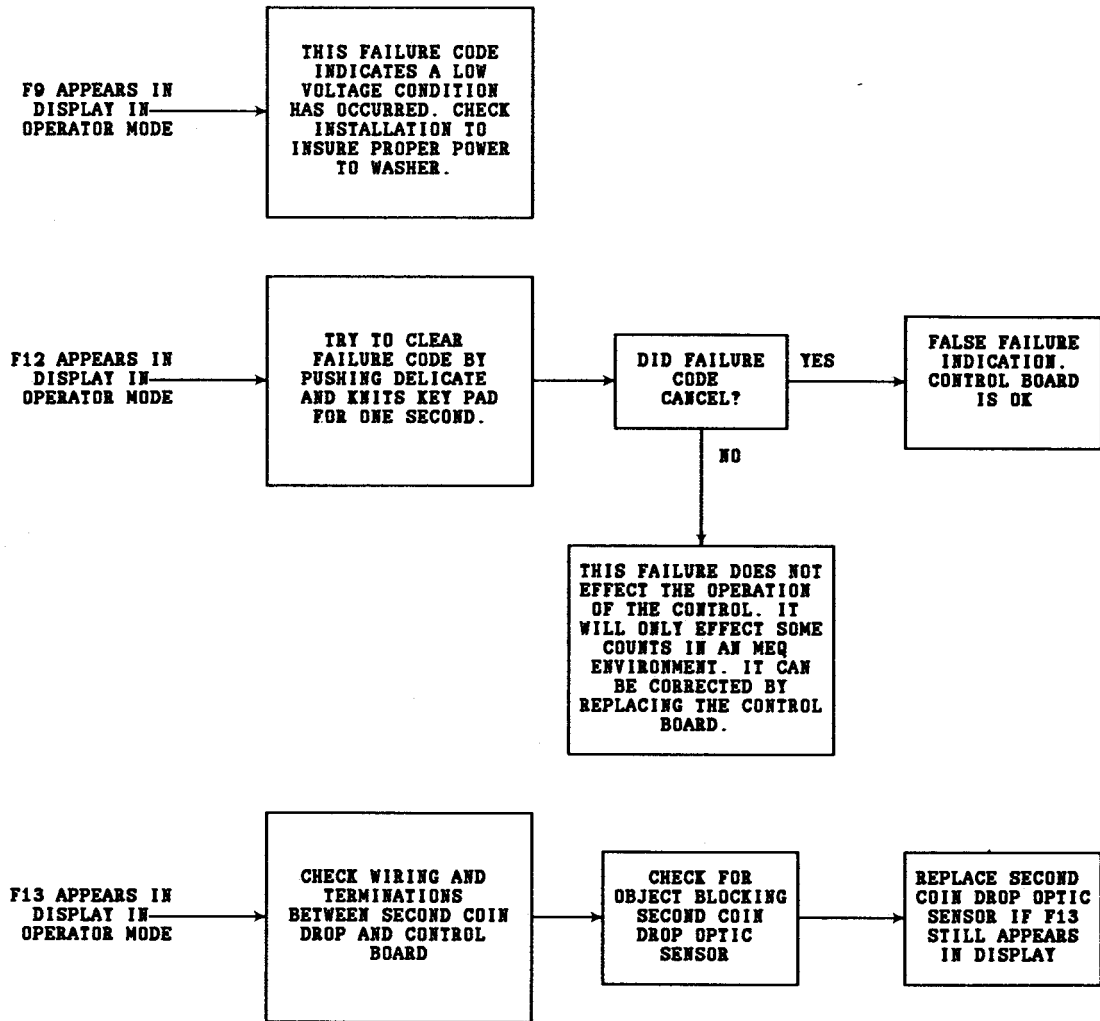



---

## SECTION 5. SPECIFICATIONS AND WIRING SCHEMATICS

---

### GENERAL SPECIFICATIONS

<b>DIMENSIONS</b>	Height to top of cabinet 36"; Height to top of control center (CS, DA, and PD models 43 1/4", MN models 42 1/4"); Height (lid open 52 3/8"); Width 25 1/2"; Depth 27" including 1 1/2" overhang.
<b>METERED FILL</b>	Water level not dependent on water pressure or time.
<b>CYCLE TIME</b>	19 minutes plus fill time. (Extended rinse settings will affect cycle time.)
<b>WASH TIME</b>	10 minutes.
<b>FILL HOSE LENGTH</b>	4 feet.
<b>DRAIN HOSE LENGTH</b>	4 feet.
<b>MOTOR</b>	1/2 H.P., 120 volt, 60 Hz, Single speed, reversible and thermoprotected.

# WATER CONSUMPTION

## Model MAT11MN, MAT11PD

	HOT	COLD	TOTAL
<b>White</b>	19 Gal. 15.8 Imp. Gal. 71.9 Liters	21 Gal. 17.4 Imp. Gal. 79.4 Gal.	40 Gal. 33.2 Imp. Gal. 151.3 Liters
<b>Colors</b>	9.5 Gal. 7.9 Imp. Gal. 36 Liters	30.5 Gal. 25.3 Imp. Gal. 115.4 Liters	40 Gal. 33.2 Imp. Gal. 151.4 Liters
<b>Bright Colors</b>	-- Gal. -- Imp. Gal. -- Liters	40 Gal. 33.2 Imp. Gal. 151.4 Liters	40 Gal. 33.2 Imp. Gal. 151.4 Liters
<b>Permanent Press</b>	9.5 Gal.	33.5 Gal.	43 Gal.
<b>(With Cool-Down)</b>	7.9 Imp. Gal. 36 Liters	27.9 Imp. Gal. 127 Liters	35.8 Imp. Gal. 163 Liters
<b>Wool</b>	-- Gal. -- Imp. Gal. -- Liters	40 Gal. 33.2 Imp. Gal. 151.4 Liters	40 Gal. 33.2 Imp. Gal. 151.4 Liters
<b>Delicate &amp; Knits</b>	9.5 Gal. 7.9 Imp. Gal. 36 Liters	30.5 Gal. 25.3 Imp. Gal. 115.4 Liters	40 Gal. 33.2 Imp. Gal. 151.4 Liters

**Note:** Water consumption is approximate.

\* Extra rinse option on MAT11PD will add approximately 14 gallons of cold water.



## Model MAT10CS, MAT10DA, MAT10PD

	HOT	COLD*	TOTAL
<b>White</b>	16 Gal. 13.3 Imp. Gal. 60.6 Liters	18 Gal. 17.9 Imp. Gal. 68.1 Gal.	34 Gal. 28.2 Imp. Gal. 128.7 Liters
<b>Colors</b>	8 Gal. 6.7 Imp. Gal. 30.2 Liters	26 Gal. 22 Imp. Gal. 98.4 Liters	34 Gal. 28.7 Imp. Gal. 128.6 Liters
<b>Bright Colors</b>	-- Gal. -- Imp. Gal. -- Liters	34 Gal. 28.2 Imp. Gal. 128.7 Liters	34 Gal. 28.2 Imp. Gal. 128.7 Liters
<b>Permanent Press</b>	8 Gal.	29 Gal.	37 Gal.
<b>(With Cool-Down)</b>	6.7 Imp. Gal. 30.3 Liters	24.2 Imp. Gal. 110 Liters	30.8 Imp. Gal. 140 Liters
<b>Wool</b>	-- Gal. -- Imp. Gal. -- Liters	34 Gal. 28.2 Imp. Gal. 128.7 Liters	34 Gal. 28.2 Imp. Gal. 128.7 Liters
<b>Delicate &amp; Knits</b>	8 Gal. 6.7 Imp. Gal. 30.2 Liters	26 Gal. 22 Imp. Gal. 98.4 Liters	34 Gal. 28.7 Imp. Gal. 128.6 Liters

**Note:** Water consumption is approximate.

\* Extra rinse option on MAT10PD will add approximately 14 gallons of cold water.

# CYCLE CHART

## Models MAT10CS, MAT10DA, MAT11MN

WHITE - COLORS - BRIGHT COLORS	
<b>SEQUENCE:</b>	
Fill for wash (hot, warm, or cold water)	Metered
Wash (Agitation)	10 min.
Pause	--
Spin	1 1/2 min.
Spin/Spray rinse	1/2 min.
Spin	2 min.
Fill for rinse (cold water)	Metered
Rinse (Agitation)	1 min.
Pause	--
Spin	5 min.
PERMANENT PRESS	
<b>SEQUENCE:</b>	
Fill for wash (warm water)	Metered
Wash (Agitation)	10 min.
Pause	--
Spin	1 min.
Spin /Spray rinse	1 min.
Spin	1/2 min.
Fill for rinse (cold water)	Metered
Rinse (Agitation)	1 min.
Pause	--
Spin	4 min.
Pause	--
WOOLENS - DELICATES & KNITS	
<b>SEQUENCE:</b>	
Fill for wash (cold water)	Metered
Wash Agitate	1 min.
Soak	4 min.
Wash Agitate	1/2 min.
Soak	4 min.
Wash Agitate	1/2 min.

Pause	--
<b>WOOLENS - DELICATES &amp; KNITS (Continued)</b>	
Spin	1 1/2 min.
Spin /Spray rinse	1/2 min.
Spin	2 min.
Fill for rinse (cold water)	Metered
Rinse (Agitation)	1 min.
Pause	--
Spin	5 min.

**Notes:**

1. All listed times in cycle chart are approximate.
2. Agitation time in the rinse cycle can be wired for 1 or 3 minutes.
3. Two short spray rinses will occur during the final spin.
4. Poor drain installation could eliminate the spray rinses. The pressure switch must reset for spray rinses to occur.

## Model MAT10PD, MAT11PD

<b>WHITE - COLORS - BRIGHT COLORS</b>	
<b>SEQUENCE:</b>	
Fill for Wash (hot, warm, or cold water)	Metered
Wash (Agitate)	10 min.
Pause	--
Spin	1 1/2 min
Spin/Spray Rinse	1/2 min.
Spin	1 min.
Fill for Rinse (cold water)	Metered
Rinse (Agitate)	1 min.
Pause	--
Spin	1 min.
Spin/Spray Rinse	3 sec.
Spin	1/2 min.
Spin/Spray Rinse	3 sec.
Spin	3 1/2 min.
<b>PERMANENT PRESS</b>	
<b>SEQUENCE:</b>	
Fill for Wash (warm water)	Metered
Wash (Agitate)	10 min.
Pause	--
Spin	1 min.
Spin/Spray Rinse	1 min.
Spin	1/2 min.
Fill for Rinse (cold water)	Metered
Rinse (Agitate)	1 min.
Pause	--
Spin	1 min.
Spin/Spray Rinse	3 sec.
Spin	3 min.
<b>WOOLENS - DELICATES &amp; KNITS</b>	
<b>SEQUENCE:</b>	
Fill for wash (cold water)	Metered
Wash (Agitate)	1 min.
Soak	3 min.

Wash (Agitate)	1/2 min.
<b>WOOLENS - DELICATES &amp; KNITS</b>	
Soak	3 min.
Wash (Agitate)	1/2 min.
Pause	--
Spin	1 1/2 min.
Spin/Spray Rinse	1/2 min.
Spin	1 min.
Fill for rinse (cold water)	Metered
Rinse (Agitate)	1 min.
Pause	--
Spin/Spray Rinse	3 sec.
Spin	1/2 min.
Spin/Spray Rinse	3 sec.
Spin	3 1/2 min.
<b>OPTIONAL RINSE SEQUENCE</b>	
<b>SEQUENCE:</b>	
Pause	--
Spin	2 min.
Fill (cold water)	Metered
Rinse	1 min.

**Notes:**

1. All listed times in cycle chart are approximate.
2. Agitation time in the wash cycle can be adjusted from 8-15 minutes for all programs except woolens, delicates & knits.
3. The number of rinse cycles is adjustable from 1-2 rinses for all programs except woolens, delicates & knits.
4. The rinse cycle agitation time is adjusted from 1-4 minutes for all programs except woolens, delicates & knits.
5. Poor drain installation could eliminate the spray rinses. The pressure switch must reset for spray rinses to occur.





# WIRING SCHEMATIC - MAT10PD, MAT11PD

FUNCTION	CONTACTS	CONTACTS CLOSED											
REVERSING RELAY ENERGIZED	BU TO WH YL TO RD												
REVERSING RELAY NONENERGIZED	BU TO RD YL TO WH												
MOTOR RELAY NON-SOAK CYCLES	GY TO BK												
MOTOR RELAY CYCLES WITH SOAK	GY TO BK												
COLD WATER VALVE	BU-BK												
HOT WATER VALVE	ORANGE												

1. OPTIONAL SECOND RINSE IS NOT AVAILABLE ON "WOOLENS" OR "DELICATES & KNITS" CYCLES.

2. THE TIME REMAINING SHOWN IN THE DISPLAY IS READJUSTED BY THE CONTROL AFTER EACH FILL.

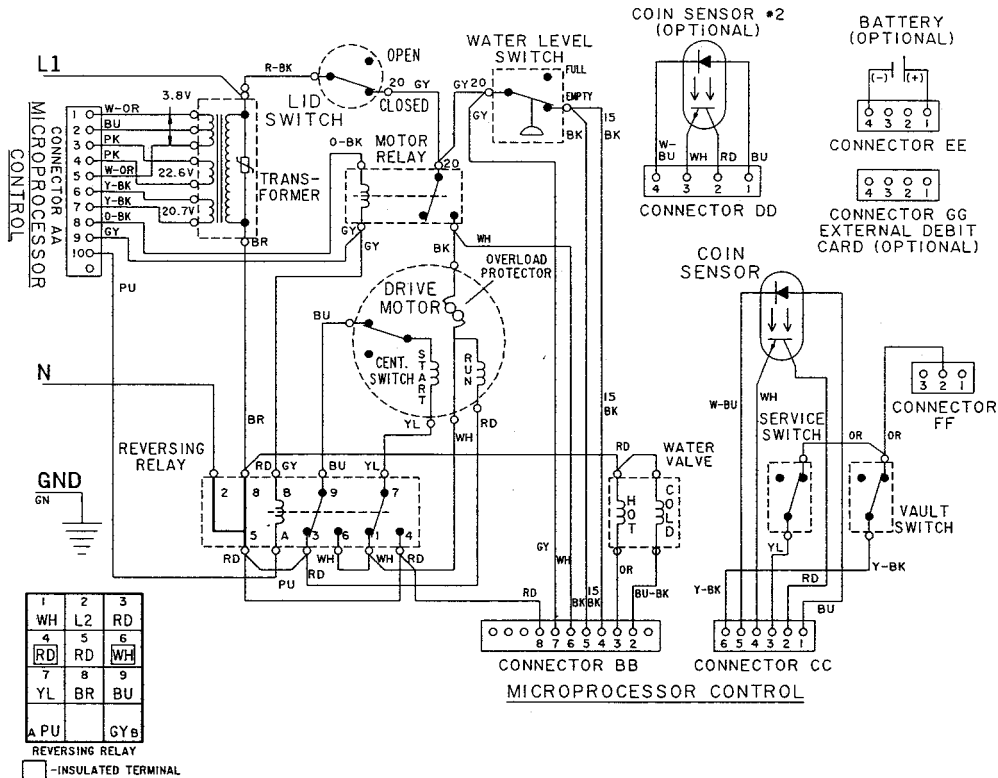

561VA-0393

2162400



# WIRING SCHEMATIC - MAT11MN

TIMER INFORMATION			TIME CHART - 30 SECONDS PER INCREMENT																			
CAM NO.	CIRCUIT	FUNCTION	5	10	15	20	25	30	35	40	45											
0	8B-37	ON-OFF	[Hatched]																			
1	7T-7A	WASH FILL	[Hatched]																			
	7T-3	RINSE FILL	[Hatched]																			
2	22-9	REVERSING- AGITATE	[Hatched]																			
	22-32	REVERSING- SPIN	[Hatched]																			
3	PL12-13	P.P. COOL DOWN OR TM	[Hatched]																			
	PL12-7T	FILL	[Hatched]																			
4	21-9	REVERSING- SPIN	[Hatched]																			
	21-32	REVERSING- AGITATE	[Hatched]																			
5	TM11-II	TIMER MOTOR	[Hatched]																			
	TM11-UL	TIMER MOTOR- LID SW. BYPASS	[Hatched]																			
6	PL3-J1	RINSE TIME SEGMENT	[Hatched]																			
	PL3-18	WOOL-DELICATE AGITATE	[Hatched]																			
7	32-PL5	SOAK INDICATOR	[Hatched]																			
	32-10	REGULAR SPIN	[Hatched]																			
8	16TM-28	START CONTROL- DA	[Hatched]																			
	16TM-14	REG. AGITATE- P.P. SPIN	[Hatched]																			
9	20-PL2	RINSE INDICATOR	[Hatched]																			
	20-PL4	FINAL SPIN INDICATOR	[Hatched]																			
10	16TM-20	TM BYPASS	[Hatched]																			
	16TM-J2	RINSE TIME SEGMENT	[Hatched]																			

<input checked="" type="checkbox"/> CONTACTS CLOSED EXCEPT FOR SORT PAUSE	PERMANENT PRESS	OFF	FILL	FILL	FILL-WASH	SPIN	4 MIN	PAUSE
<input type="checkbox"/> CONTACTS OPEN	WHITES, COLORS AND BRIGHT COLORS	OFF	FILL	FILL	FILL-WASH	SPIN	5 MIN	
<input checked="" type="checkbox"/> CONTACTS CLOSED	DELICATES, KNITS AND WOOL	OFF	FILL	WASH	SOAK	WASH	SOAK	SPIN
<input checked="" type="checkbox"/> CONTACTS MAY BE OPEN OR CLOSED								
<input checked="" type="checkbox"/> CONTACTS CLOSED FOR SHORT TIME								

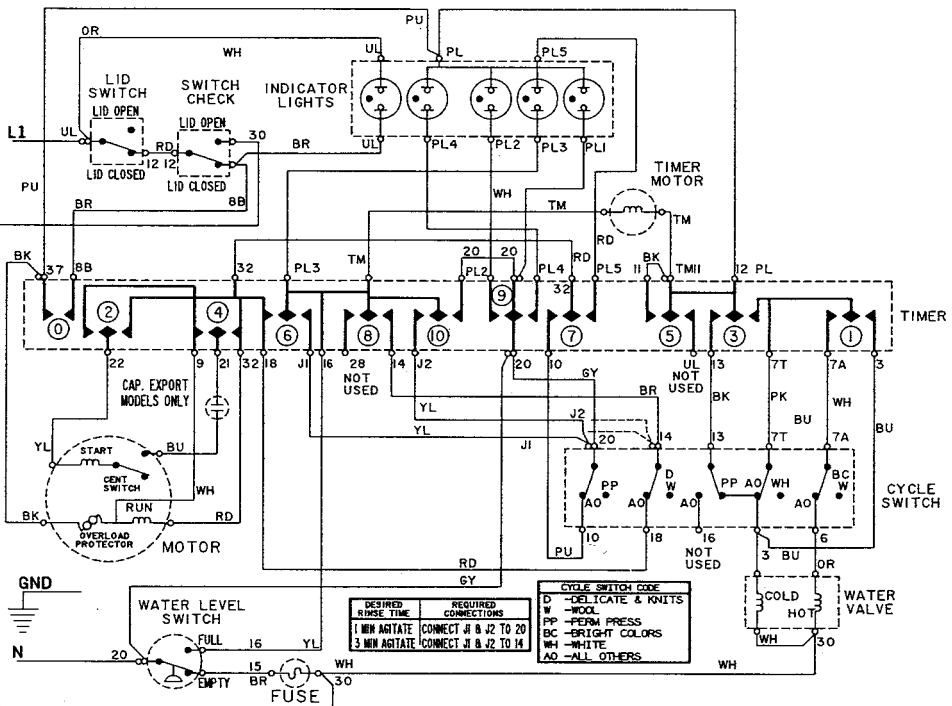

564VA-0393

2162430





**MAYTAG**

Maytag Appliances Sales Company

Customer Service  
240 Edwards St.  
Cleveland, TN 37311