

ML-1

MAYTAG®
TECHNICAL EDUCATION

Epic™

**FRONT-LOADING
AUTOMATIC WASHER**



**MODEL MFW 9700S
MFW 9600S**

JOB AID 8178604

FORWARD

This Maytag Job Aid Epic Front-Loading Automatic Washer” (Part No. 8178604), provides the In Home Service Professional with information on the installation, operation, and service of the Front-Loading Automatic Washer. It is to be used as a training Job Aid and Service Manual. For specific information on the model being serviced, refer to the “Use and Care Guide,” or “Tech Sheet” provided with the washer.

The Wiring Diagram used in this Job Aid is typical and should be used for training purposes only. Always use the Wiring Diagram supplied with the product when servicing the unit.

GOALS AND OBJECTIVES

The goal of this Job Aid is to provide detailed information that will enable the In Home Service Professional to properly diagnose malfunctions and repair the Maytag Epic Front-Loading Automatic Washer.

The objectives of this Job Aid are to:

- Understand and follow proper safety precautions.
- Successfully troubleshoot and diagnose malfunctions.
- Successfully perform necessary repairs.
- Successfully return the washer to its proper operational status.

WHIRLPOOL CORPORATION assumes no responsibility for any repairs made on our products by anyone other than Authorized In Home Service Professionals.

TABLE OF CONTENTS

	Page
GENERAL	1-1
Safety First	1-1
Model & Serial Number Designations	1-2
Model & Serial Number Label And Tech Sheet Locations	1-3
Specifications	1-4
Maytag Washer Warranty	1-5
INSTALLATION INFORMATION	2-1
Installation Requirements	2-1
Installation Instructions	2-4
PRODUCT OPERATION	3-1
Theory Of Operation	3-1
Washer Use	3-7
Cycles	3-8
Options	3-12
Modifiers	3-12
COMPONENT ACCESS	4-1
Component Locations	4-1
Removing The Console And The Touchpad/LED Assembly	4-2
Removing The Door Lock/Switch Assembly, And The Front Panel & Bellows	4-4
Removing The Flowmeter	4-7
Removing The Detergent Dispenser Motor & Assembly	4-8
Removing The Inlet Valves	4-10
Removing The Central Control Unit	4-11
Removing The Interference Filter	4-12
Removing The Pressure Switch	4-13
Removing The Motor Controller	4-14
Removing The Temperature Sensor & The Heating Element	4-16
Removing The Drain Pump Assembly	4-18
Removing The Airtrap	4-18
Removing An Interlock Switch	4-19
Removing The Drive Motor	4-21
Removing The Tub And Basket Assembly	4-23

	Page
COMPONENT TESTING	5-1
Pressure Switch	5-1
Detergent Dispenser Motor & Switch	5-2
Inlet Valve Solenoids	5-2
Door Lock/Switch Assembly	5-3
Drain Pump Motor	5-4
Interference Filter	5-4
Heating Element & Temperature Sensor	5-5
Drive Motor	5-6
Interlock Switch	5-6
DIAGNOSTICS & TROUBLESHOOTING	6-1
Diagnostics	6-1
Diagnostic Guide.....	6-1
Failure/Error Display Codes	6-2
Diagnostic Test	6-8
Control Board Removal Or Replacement.....	6-10
Troubleshooting Chart	6-11
WIRING DIAGRAM	7-1

GENERAL SAFETY FIRST

Your safety and the safety of others is very important.

We have provided many important safety messages in this Job Aid and on the appliance. Always read and obey all safety messages.

This is the safety alert symbol.



This symbol alerts you to hazards that can kill or hurt you and others.

All safety messages will follow the safety alert symbol and either the word "DANGER" or "WARNING." These words mean:

! WARNING

You can be killed or seriously injured if you don't immediately following instructions.

! DANGER

You can be killed or seriously injured if you don't follow instructions.

All safety messages will tell you what the potential hazard is, tell you how to reduce the chance of injury, and tell you what can happen if the instructions are not followed.

MODEL & SERIAL NUMBER DESIGNATIONS

MODEL NUMBER

MODEL NUMBER	M	F	W	9	6	00	S	Q	0
PRODUCT GROUP	M = Maytag								
ACCESS	F = Front Loading T = Top Loading								
PRODUCT	W = Washer								
SERIES	5 = LEAP 6 = Oasis								
	7 = 24" Front Load 8 = Mid Line Front Load								
	9 = Full Size Front Load								
PRICE POINT LEVEL (1-9)									
TRADE PARTNER ID	00 = Branded								
YEAR OF INTRODUCTION	S = 2006, T = 2007								
COLOR CODE	B = Black Q = White								
ENGINEERING CHANGE									

SERIAL NUMBER

SERIAL NUMBER	CS	T	32	02031
DIVISION = Schorndorf, Germany				
YEAR OF PRODUCTION		T = 2006		
WEEK OF PRODUCTION			32 = 32nd Week	
PRODUCT SEQUENCE NUMBER				

MODEL & SERIAL NUMBER LABEL AND TECH SHEET LOCATIONS

The Model/Serial Number label and Tech Sheet locations are shown below.

**Model & Serial
Number Label
Location**



**Tech Sheet Location
(Behind Toe Panel)**

SPECIFICATIONS

MODEL	MFW9700S	MFW9600S
Capacity (cu. ft.)	3.8 I.E.C.	3.8 I.E.C.
Wash Cycles	12	12
Wash Options	4	3
Max Spin Speed	1200 rpm	1000 rpm
1000W Heater	Yes	Yes
Top	Porcelain	Painted
Color	Silver on White Silver on Black	White on White
Dimensions	38" H x 27" W x 31 1/2" D	38" H x 27" W x 31 1/2" D

MAYTAG CORPORATION MAJOR APPLIANCE WARRANTY

ONE YEAR LIMITED WARRANTY

For one year from the date of purchase, when this major appliance is operated and maintained according to instructions attached to or furnished with the product, Maytag Corporation or Maytag Limited (hereafter "Maytag") will pay for Factory Specified Parts and repair labor to correct defects in materials or workmanship. Service must be provided by a Maytag designated service company. This limited warranty applies only when the major appliance is used in the country in which it was purchased.

ITEMS MAYTAG WILL NOT PAY FOR

1. Service calls to correct the installation of your major appliance, to instruct you how to use your major appliance, to replace or repair house fuses or to correct house wiring or plumbing.
 2. Service calls to repair or replace appliance light bulbs, air filters or water filters. Those consumable parts are excluded from warranty coverage.
 3. Repairs when your major appliance is used for other than normal, single-family household use.
 4. Damage resulting from accident, alteration, misuse, abuse, fire, flood, acts of God, improper installation, installation not in accordance with electrical or plumbing codes, or use of products not approved by Maytag.
 5. Any food loss due to refrigerator or freezer product failures.
 6. Replacement parts or repair labor costs for units operated outside the United States or Canada.
 7. Pickup and delivery. This major appliance is designed to be repaired in the home.
 8. Repairs to parts or systems resulting from unauthorized modifications made to the appliance.
 9. Expenses for travel and transportation for product service in remote locations.
 10. The removal and reinstallation of your appliance if it is installed in an inaccessible location or is not installed in accordance with published installation instructions.
 11. Replacement parts or repair labor costs when the major appliance is used in a country other than the country in which it was purchased.
-

DISCLAIMER OF IMPLIED WARRANTIES; LIMITATION OF REMEDIES

CUSTOMER'S SOLE AND EXCLUSIVE REMEDY UNDER THIS LIMITED WARRANTY SHALL BE PRODUCT REPAIR AS PROVIDED HEREIN. IMPLIED WARRANTIES, INCLUDING WARRANTIES OF MERCHANTABILITY OR FITNESS FOR A PARTICULAR PURPOSE, ARE LIMITED TO ONE YEAR OR THE SHORTEST PERIOD ALLOWED BY LAW. MAYTAG SHALL NOT BE LIABLE FOR INCIDENTAL OR CONSEQUENTIAL DAMAGES. SOME STATES AND PROVINCES DO NOT ALLOW THE EXCLUSION OR LIMITATION OF INCIDENTAL OR CONSEQUENTIAL DAMAGES, OR LIMITATIONS ON THE DURATION OF IMPLIED WARRANTIES OF MERCHANTABILITY OR FITNESS, SO THESE EXCLUSIONS OR LIMITATIONS MAY NOT APPLY TO YOU. THIS WARRANTY GIVES YOU SPECIFIC LEGAL RIGHTS AND YOU MAY ALSO HAVE OTHER RIGHTS, WHICH VARY FROM STATE TO STATE OR PROVINCE TO PROVINCE.

Outside the 50 United States and Canada, this warranty does not apply. Contact your authorized Maytag dealer to determine if another warranty applies.

If you need service, first see the "Troubleshooting" section of the Use & Care Guide. After checking "Troubleshooting," additional help can be found by checking the "Assistance or Service" section or by calling Maytag. In the U.S.A., call **1-800-688-9900**. In Canada, call **1-800-688-2002**. 5/06

Keep this book and your sales slip together for future reference. You must provide proof of purchase or installation date for in-warranty service.

Write down the following information about your major appliance to better help you obtain assistance or service if you ever need it. You will need to know your complete model number and serial number. You can find this information on the model and serial number label located on the product.

Dealer name _____

Address _____

Phone number _____

Model number _____

Serial number _____

Purchase date _____

— NOTES —

INSTALLATION REQUIREMENTS

Tools and Parts

Gather the required tools and parts before starting installation. The parts supplied are in the washer drum.

Tools needed for connecting the water inlet hoses

- Pliers (that open to 1 9/16" [39.5 mm])
- Flashlight (optional)

Tools needed for installation

- Open end wrenches 17 mm and 13 mm
- Level
- Wood block
- Ruler or measuring tape

Parts supplied:

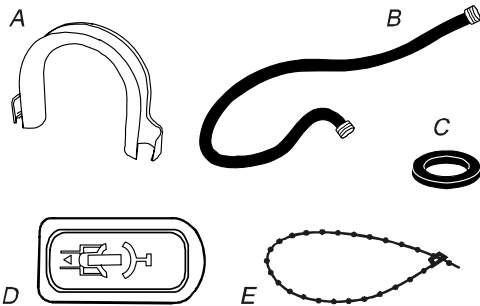

- A. Drain hose form
- B. Inlet hose (2)
- C. Inlet hose washer (4)
- D. Transport bolt hole plug (4)
- E. Beaded strap

Alternate Parts

Your installation may require additional parts. If you are interested in purchasing one of the items listed here, call the toll-free number on the cover or in the Assistance or Service section.

If You Have	You Will Need to Buy
Laundry tub or standpipe taller than 96" (2.4 m)	Sump pump system (if not already available)
Overhead sewer	Standard 20 gal. (76 L), 30" (76.2 cm) tall drain tub or utility sink and sump pump (available from local plumbing suppliers)
Floor drain	Siphon break, Part Number 285834; additional drain hose Part Number 8318155; and connector kit, Part Number 285835
Drain hose too short	4 ft (1.2 m) drain hose extension kit, Part Number 285863
Water faucets beyond reach of fill hoses	2 longer water fill hoses: 6 ft (1.8 m) Part Number 76314, 10 ft (3.0 m) Part Number 350008

Options

Pedestal

A pedestal will add to the total height of the washer for a total height of 53.5" (135.9 cm).

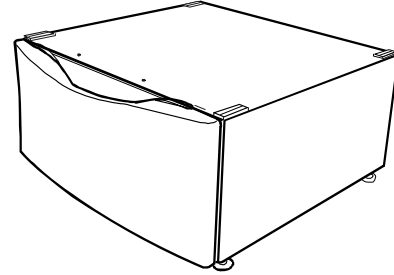

Optional pedestal

To order, call the dealer from whom you purchased your washer or refer to the Assistance or Service section of this manual.

Pedestal Height	Color	Part Number
15.5" (39.4 cm)	White	WHP1500SQ
15.5" (39.4 cm)	Black	WHP1500SB

Stack Kit

Are you planning to stack your Maytag washer and dryer? To do so you will need to purchase a Stack Kit.

To order, call the dealer from whom you purchased your dryer or refer to the Assistance or Service section of this manual. Ask for Part Number 8541503.

Location Requirements

Selecting the proper location for your washer improves performance and minimizes noise and possible washer "walk."

Your washer can be installed under a custom counter, or in a basement, laundry room, closet, or recessed area. See "Drain System."

Companion appliance location requirements should also be considered. Proper installation is your responsibility.

You will need

A water heater set to deliver 120 °F (49°C) water to the washer.

A grounded electrical outlet located within 6 ft (1.8 m) of where the power cord is attached to the back of the washer. See Electrical Requirements.

Hot and cold water faucets located within 4 ft (1.2 m) of the hot and cold water fill valves, and water pressure of 20-100 psi (137.9-689.6 kPa).

A level floor with a maximum slope of 1" (2.5 cm) under entire washer. Installing the washer on soft floor surfaces, such as carpets or surfaces with foam backing, is not recommended.

A sturdy and solid floor to support the washer with a total weight (water and load) of 400 lbs (180 kg).

Do not operate your washer in temperatures below 32 °F (0°C). Some water can remain in the washer and can cause damage in low temperatures.

Installation clearances

The location must be large enough to allow the washer door to be fully opened.

Additional spacing should be considered for ease of installation and servicing.

Additional clearances might be required for wall, door, and floor moldings.

Additional spacing of 1" (2.5 cm) on all sides of the washer is recommended to reduce noise transfer.

Companion appliance spacing should also be considered.

Washer Dimensions

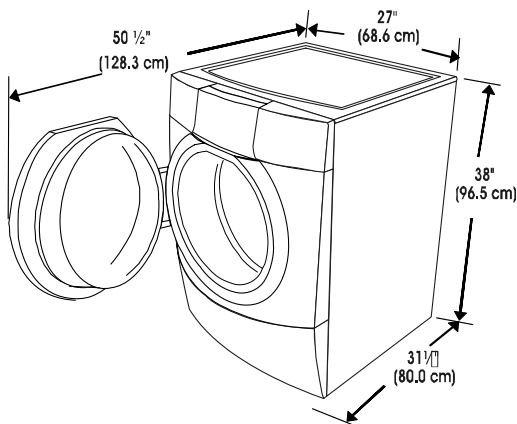

Recommended installation spacing for custom undercounter installation

The dimensions shown are for the recommended spacing.

Custom undercounter installation - Washer only

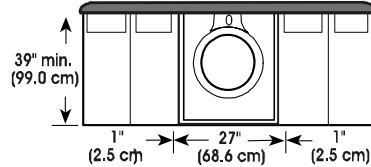

Recommended installation spacing for recessed or closet installation, with or without a pedestal

The dimensions shown are for the recommended spacing.

Recessed area or closet installation

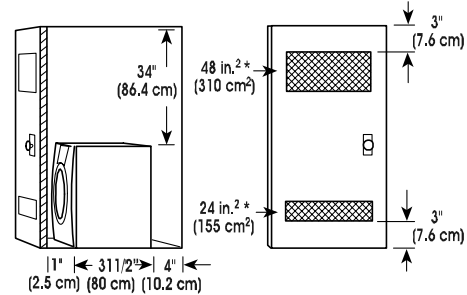

A Side view - closet or confined area
B Closet door with vents

Recessed or closet installation - Washer on pedestal

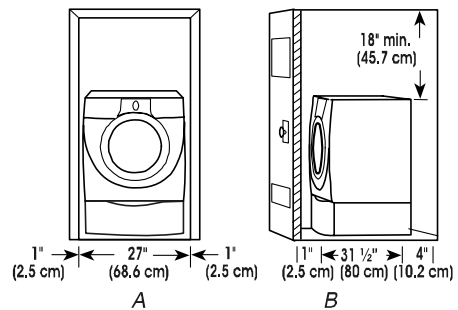

A Recessed area
B Side view - closet or confined area

Recommended installation spacing for recessed or closet installation, with stacked washer and dryer

The dimensions shown are for the recommended spacing.

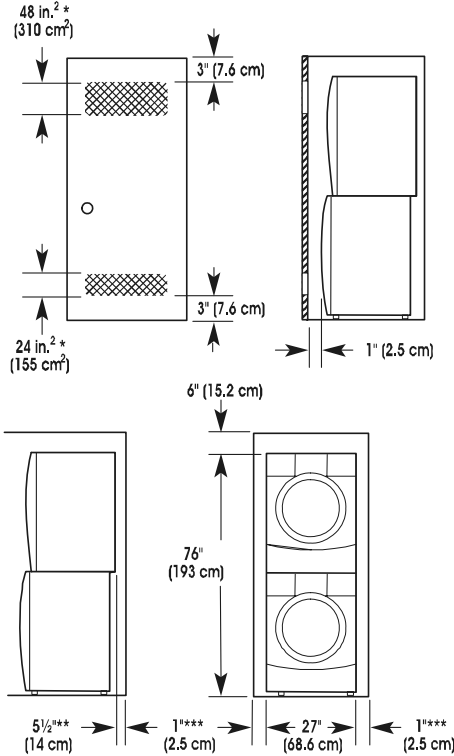

* Min. top and bottom air openings for closet door.

** External exhaust elbow requires additional space.

*** Wall, door and floor molding may require additional spacing.

Recommended installation spacing for cabinet installation

The dimensions shown are for the recommended spacing.

For cabinet installation, with a door, the minimum ventilation openings in the top are required.

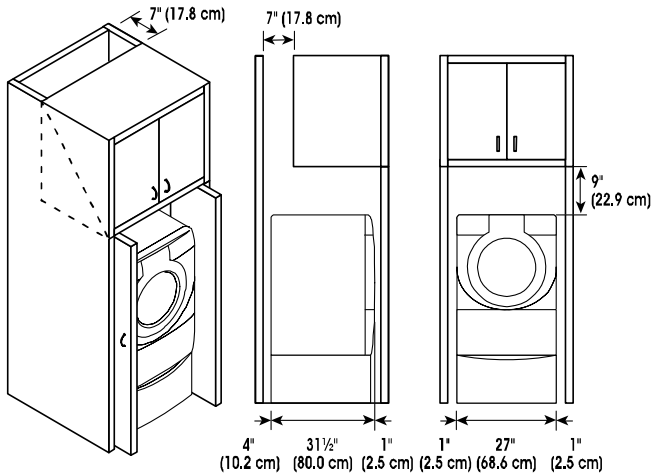

Drain System

The washer can be installed using the standpipe drain system (floor or wall), the laundry tub drain system, or the floor drain system. Select the drain hose installation method you need. See ?Tools and Parts. ?

Standpipe drain system - wall or floor (views A & B)

The standpipe drain requires a minimum diameter standpipe of 2" (5 cm). The minimum carry-away capacity can be no less than 17 gal. (64 L) per minute.

The top of the standpipe must be at least 30" (76.2 cm) high and no higher than 96" (2.4 m) from the bottom of the washer.

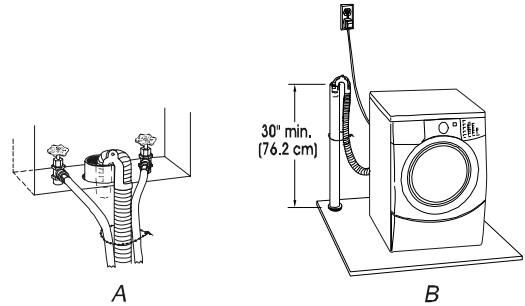

Laundry tub drain system (view A)

The laundry tub needs a minimum 20 gal. (76 L) capacity. The top of the laundry tub must be at least 30" (76.2 cm) above the floor.

Floor drain system (view B)

The floor drain system requires a siphon break that may be purchased separately. See Tools and Parts.

The siphon break must be a minimum of 28" (71 cm) from the bottom of the washer. Additional hoses might be needed.

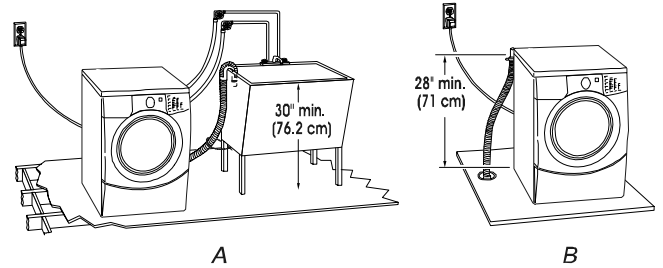

Electrical Requirements

WARNING



Electrical Shock Hazard

Plug into a grounded 3 prong outlet.
Do not remove ground prong.
Do not use an adapter.
Do not use an extension cord.
Failure to follow these instructions can result in death, fire, or electrical shock.

A 120-volt, 60-Hz., AC-only, 15- or 20-amp, fused electrical supply is required. Time-delay fuse or circuit breaker is recommended. It is recommended that a separate circuit serving only this appliance be provided.

This washer is equipped with a power supply cord having a 3 prong grounding plug.

To minimize possible shock hazard, the cord must be plugged into a mating, 3 prong, grounding-type outlet, grounded in accordance with local codes and ordinances. If a mating outlet is not available, it is the personal responsibility and obligation of the customer to have the properly grounded outlet installed by a qualified electrician.

If codes permit and a separate ground wire is used, it is recommended that a qualified electrician determine that the ground path is adequate.

Do not ground to a gas pipe.

Check with a qualified electrician if you are not sure the washer is properly grounded.

Do not have a fuse in the neutral or ground circuit.

GROUNDING INSTRUCTIONS

For a grounded, cord-connected washer:

This washer must be grounded. In the event of a malfunction or breakdown, grounding will reduce the risk of electrical shock by providing a path of least resistance for electric current. This washer is equipped with a cord having an equipment-grounding conductor and a grounding plug. The plug must be plugged into an appropriate outlet that is properly installed and grounded in accordance with all local codes and ordinances.

WARNING: Improper connection of the equipment-grounding conductor can result in a risk of electric shock. Check with a qualified electrician or serviceman if you are in doubt as to whether the appliance is properly grounded.

Do not modify the plug provided with the appliance ? if it will not fit the outlet, have a proper outlet installed by a qualified electrician.

For a permanently connected washer:

This washer must be connected to a grounded metal, permanent wiring system, or an equipment grounding conductor must be run with the circuit conductors and connected to the equipment-grounding terminal or lead on the appliance.

INSTALLATION INSTRUCTIONS

Remove Transport System

WARNING

Excessive Weight Hazard

Use two or more people to move and install washer.
Failure to do so can result in back or other injury.

IMPORTANT: Position the washer so that the rear of the washer is within approximately 3 ft (90 cm) of its final location.

There are 4 bolts in the rear panel of the washer that support the suspension system during transportation. These bolts also retain the power cord inside the washer until the bolts are removed.

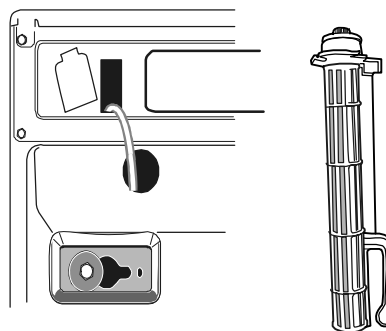

1. Using a 13 mm wrench, loosen each of the bolts.

- Once the bolt is loose, move it to the center of the hole and completely pull out the bolt, including the plastic spacer covering the bolt.

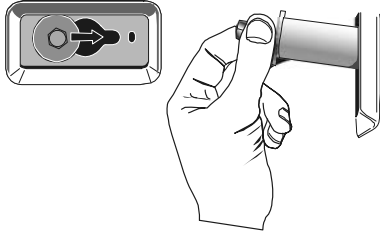

- Once all 4 bolts are removed discard bolt and spacers. Then pull the power cord through the opening of the rear panel and close the hole with the attached cap.
- Close the bolt holes with the 4 transport bolt hole plugs.

NOTE: If the washer is to be transported at a later date, call your local service center. To avoid suspension and structural damage to your washer, it must be properly set up for relocation by a certified technician.

Connect the Inlet Hoses

Make sure the washer drum is empty.

- Attach the hose with the red color indicator to the Hot (left) inlet valve. Attaching the red coupling first makes it easier to tighten connection with pliers. Screw on coupling by hand until it is seated on the washer.
- Attach the hose with the blue color indicator to the Cold (right) water inlet valve. Screw on coupling by hand until it is seated on the washer.

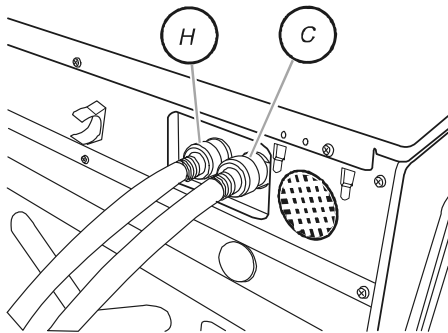

H. Hot water inlet
C. Cold water inlet

- Using pliers, check the tightness of the hose couplings already attached to the washer.
NOTE: Do not overtighten. Damage to the coupling can result.
- Attach the hose with the red color indicator to the hot water faucet. Screw on coupling by hand until it is seated on the washer.
- Attach the hose with the blue color indicator to the cold water faucet. Screw on coupling by hand until it is seated on the washer.

- Using pliers, tighten the couplings with an additional two-thirds turn.

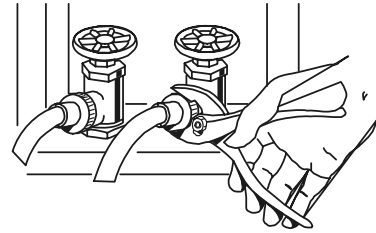

NOTE: Do not overtighten. Damage to the coupling can result.

- Turn on the water faucets and check for leaks.

NOTE: Replace inlet hoses after 5 years of use to reduce the risk of hose failure. Record hose installation or replacement dates on the hoses for future reference.

Periodically inspect and replace hoses if bulges, kinks, cuts, wear, or leaks are found.

Route the Drain Hose

Proper routing of the drain hose protects your floors from damage due to water leakage. Read and follow these instructions.

Remove drain hose from washer cabinet

Gently pull the corrugated drain hose from the shipping clips.

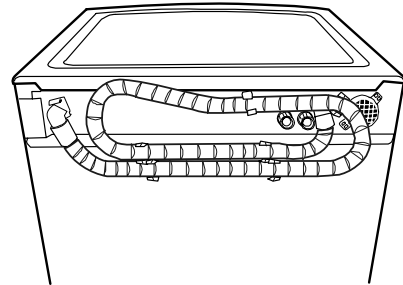

Laundry tub drain or standpipe drain

Connect the drain hose form to the corrugated drain hose.

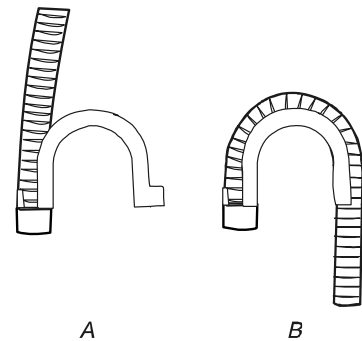

- Snap either end of the drain hose form to the drain hose at the point where the corrugation begins.
- Bend drain hose over drain hose form and snap into place.

To keep drain water from going back into the washer:

Do not straighten the drain hose, and do not force excess drain hose into standpipe. Hose should be secure, but loose enough to provide a gap for air.

Do not lay excess hose on the bottom of the laundry tub.

Floor drain

You may need additional parts. See Floor drain under Tools and Parts.

Secure the Drain Hose

1. Drape the power cord over the washer top.
2. Secure the drain hose to the laundry tub leg or standpipe with the beaded strap provided. (See illustrations A and B.)

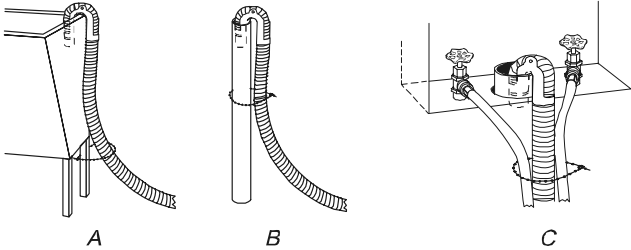

If the washer faucets and the drain standpipe are recessed (see illustration C), put the hooked end of the drain hose in the standpipe. Tightly wrap the beaded strap around the water inlet hoses and the drain hose.

Do not force excess drain hose into the standpipe.

Level the Washer

Properly leveling your washer avoids excessive noise and vibration.

1. Check the levelness of the washer by placing a level on the top edge of the washer, first side to side, then front to back.

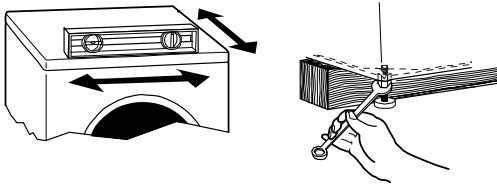

If the washer is against a wall, move the washer out slightly before tipping back. If the washer is not level, first prop the front with a wood block and adjust the feet as necessary; then prop the back and adjust feet as necessary. Repeat this step until washer is level.

2. Make sure all four feet are stable and resting on the floor. Then check that the appliance is perfectly level (use a level).
3. After the washer is level, use a 17 mm open-end wrench to turn the nuts on the feet tightly against the washer cabinet.

IMPORTANT: All four feet must be tightened. If the nuts are not tight against the washer cabinet, the washer may vibrate.

4. The washer should not move front to back, side to side, or diagonally when pushed on its top edges.
5. Slide the washer to its final location.
6. Confirm the levelness of the washer.

Complete Installation

1. Check the electrical requirements. Be sure that you have the correct electrical supply and the recommended grounding method. See "Electrical Requirements."
2. Check that all parts are now installed. If there is an extra part, go back through the steps to see which step was skipped.
3. Check that you have all of your tools.
4. Dispose of/recycle all packaging materials.
5. Check that the water faucets are on.
6. Check for leaks around faucets and inlet hoses.

⚠ WARNING



Electrical Shock Hazard

Plug into a grounded 3 prong outlet.

Do not remove ground prong.

Do not use an adapter.

Do not use an extension cord.

Failure to follow these instructions can result in death, fire, or electrical shock.

7. Plug into a grounded 3 prong outlet.
8. Read "Washer Use."
9. To test and to clean your washer, measure $\frac{1}{2}$ The detergent manufacturers Recommended amount of HE High Efficiency detergent for a medium-size load. Pour the detergent into the detergent dispenser. Select NORMAL/CASUAL, and then select HOLD TO START. Allow the washer to complete one whole cycle.



Use only HE High Efficiency detergent.

FEATURES AND BENEFITS

Electronic Controls

Flexible electronic controls are easy to use whether you are a beginner or an expert.

Smart Dispensers

The Smart Dispensers make your washer truly automatic. This washer provides a four-compartment dispenser which includes separate compartments for main wash detergent, fabric softener, bleach, and auto prewash or auto soak. The dispenser has large pour zones, is self-cleaning, and can be easily removed. Laundry additives are diluted with fresh water and added to the load at the proper time in the wash cycle.

Auto Water Level

This washer automatically adjusts water level for best cleaning and rinsing performance. Two sensors determine load size, load composition, and suds level, then the sensors adjust the water level to the proper setting. This eliminates guesswork. The water level is just right for every wash load size.

Larger Load Size

Since there is no agitator, you can wash larger, bulkier items such as a king-sized bedspread. You are also able to wash more clothes at one time, which means fewer loads.

Suspension System

To reduce washer "walk" and "off-balance" conditions, your new washer combines:

- 2 Springs to isolate vibration
- 4 Shock absorbers at the washer base to minimize movement

Stainless Steel Drum

The stainless steel drum eliminates corrosion and enables higher spin speeds for more water extraction, reducing drying time.

High-Efficiency Wash System

Your new front-loading, high-efficiency washer saves time with fewer, larger loads, and lowers your water and energy bills by helping conserve resources.

Spin Speeds

This washer automatically selects the spin speed based on the cycle selected. This factory setting can be changed, however. This washer offers up to five different spin speed choices.

Heating Element

This washer has a heating element that automatically heats the water to the best temperature on select cycles. This enables stepped cleaning, a process in which warm water is brought in and mixed with detergent first, then the water is heated. The warm water cleans stains such as blood and eggs, and the heated water removes oily stains such as perspiration and dirty mechanical oil. This heater is active in the Sanitary, Whitest Whites and Heavy Duty cycles.

Automatic Temperature Control

The automatic temperature control electronically senses and maintains a uniform water temperature. Automatic temperature control regulates incoming hot and cold water. Automatic temperature control is automatically turned On when a cycle is selected.

Add A Garment

When this option is available at the beginning of the cycle the Add A Garment status light will glow for the first 8 minutes. This washer allows an 8-minute period in which forgotten garments may be added to a load.

Special Cleaning Action with Direct Injection

This washer channels 100% of the water through the dispensers to assure thorough rinse-out and mixture of all the additives before they touch any garments. The water is then sprayed from the top front onto the center of the load, providing even distribution and optimum cleaning performance. It is normal for small amounts of water to remain in the dispensers when the wash cycle is complete.

Efficient Detergent System

This washer has a specially designed valve that closes during the wash portion of the cycle so that 100% of the water and detergent mixture is used on the load. The Efficient Detergent System ensures that no water or detergent is wasted.

Dynamic Off-Balance Detection

This washer uses two sensors to detect load size and the amount of off-balance within the load. The suspension system and controls are specially designed to redistribute the load automatically.

PRODUCT OPERATION

THEORY OF OPERATION

INTRODUCTION

The Maytag Epic Front-Loading Automatic Washer presents a number of new features and operating characteristics quite different from previous models. The washer contains a number of unique operating features designed to increase clothes cleaning ability while offering very high water and energy conservation.

WATER SYSTEM

The water system consists of the hot and cold water inlet valves, a water temperature sensor, a water flowmeter and control, and the dispenser distribution system along with a traditional pressure switch.

WATER INLET VALVES

The hot and cold water inlet valves are located at the back of the washer. These valves receive a control signal from the Central Control Unit to manage the temperature of incoming water. The temperatures are determined by the specific wash cycle selected and a temperature sensor located in the wash tub. To improve cleaning of heavily soiled clothing and to provide a sanitizing feature, the water temperature can be increased through the use of a heating element located in the bottom of the tub.

FLOWMETER

Water flow, or the quantity of water introduced throughout any cycle, is monitored by a flowmeter and Central Control Unit. When the flowmeter registers a maximum of 10.5 gal (40 L), and the Central Control Unit has not detected the pressure switch trip, the water valves will be shut off and an error code will show in the digital display.

The flowmeter is also used to introduce additional water into the tub for higher water levels, based on cycle requirements.

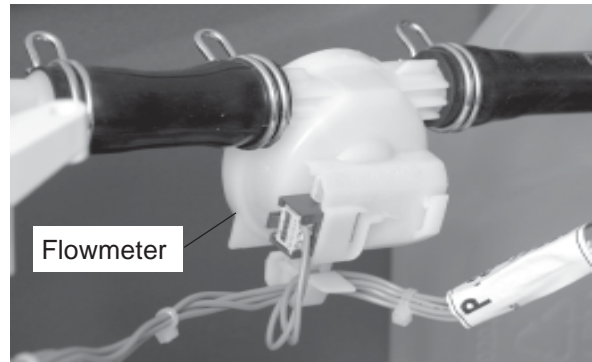

DISPENSER DISTRIBUTION SYSTEM

All wash and rinse water is introduced into the wash tub through a Dispenser Distribution System located in the top left corner of the washer. The system consists of a motor that turns a cam gear. The cam follower will divert the incoming water to one or more of the follow water inlet modes:

- Detergent Dispensing
- Bleach Dispensing
- Fabric Softener Dispensing
- Rinse Dispensing (no additives)

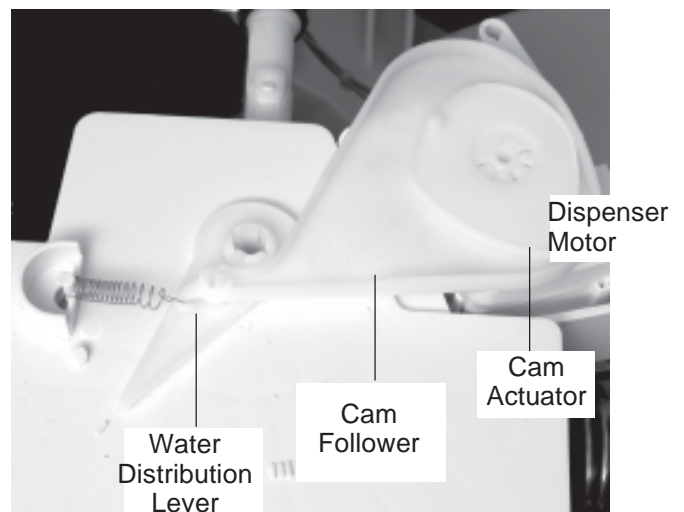

The dispenser drawer has four separate compartments for adding laundry products to the wash load. These compartments are:

1. Prewash Detergent Compartment
2. Main Wash Detergent Compartment
3. Bleach Compartment
4. Fabric Softener Compartment



Laundry products are diluted and dispensed automatically at the proper time during the wash cycle. The separator in the Prewash and Main Wash Detergent Compartment can be moved to accommodate either liquid or powdered detergents.

The drawer release lever can be installed in the stack position to accommodate stacking a matching dryer on top of the washer.

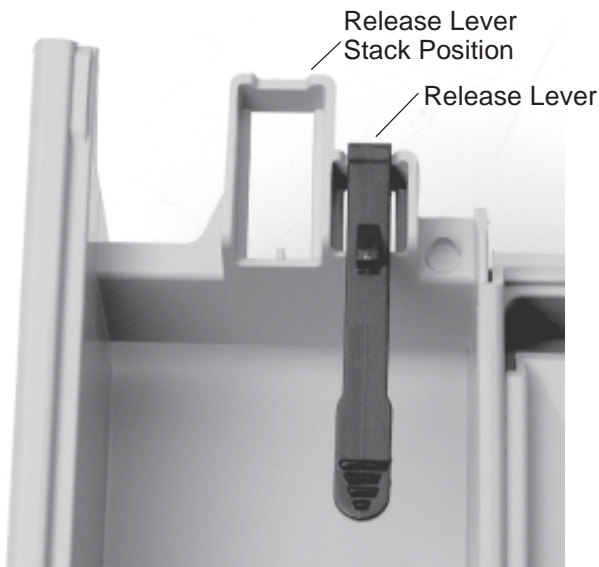

The water enters the wash tub through the main inlet tube.

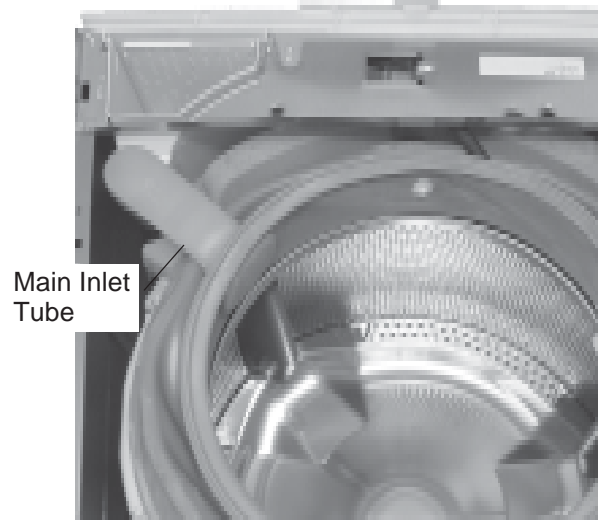

AIR VENT SYSTEM

As a safety feature, the washer is designed to allow fresh air to circulate through the tub. An inlet vent at the rear of the washer brings air into the tub. The fresh air is vented through the dispenser assembly vent tube and out the front of the dispenser drawer cutout.

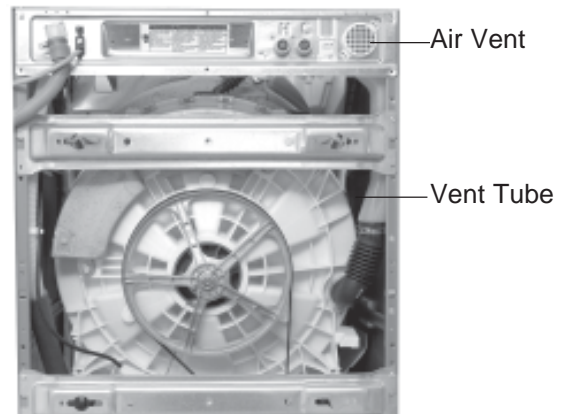

PRESSURE SWITCH

The pressure switch is located in the top right rear corner of the washer. This switch senses water level in the wash tub. The control signal from the pressure switch is sent to the Central Control Unit and is used to determine the amount of water introduced into the wash tub during the wash cycle.

The pressure switch also senses the suds level in the wash tub. If excessive sudsing occurs, the washer starts an automatic suds routine. The display will show the word "Sud." The automatic suds routine adds additional rinse and drain operations until the suds level is reduced.

If an overfill condition is detected by the pressure switch, the CCU will turn on the drain pump and attempt to stop filling.

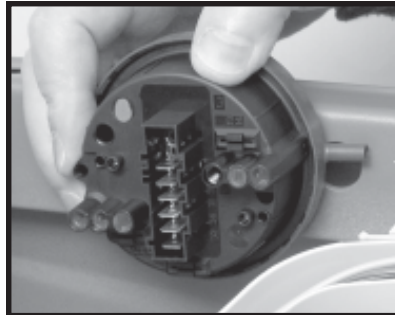

TOUCHPAD/LED ASSEMBLY

The Touchpad/LED Assembly is removed as a single assembly and is connected to the Central Control Unit by a ribbon cable. This assembly contains all of the buttons, LEDs and ribbon cable and printed circuit boards for the user to operate the washer. This interfaces the consumer inputs to the Central Control Unit.

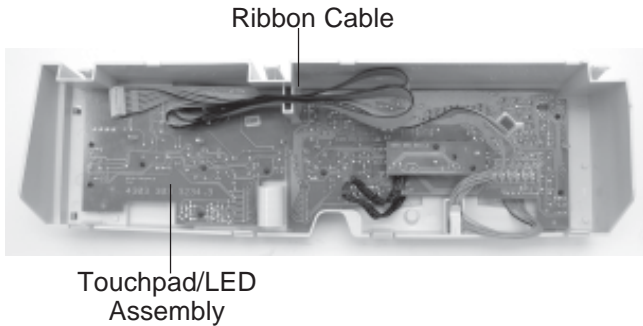

CENTRAL CONTROL UNIT (CCU)

The Central Control Unit is located at the top rear of the washer and is enclosed in a control box. There are no serviceable parts inside the control box. If diagnostic tests indicate any component of the CCU is defective, the entire control box must be replaced.

The CCU receives input from the touchpad/LED assembly and directly controls the dispenser, drain pump, water inlet valves, door locking and unlocking solenoids, and heating element relay. The CCU monitors the pressure switch, flowmeter, temperature sensor and door lock switches.

The CCU sends the customer selection input to the Motor Control Unit for proper motor operation.

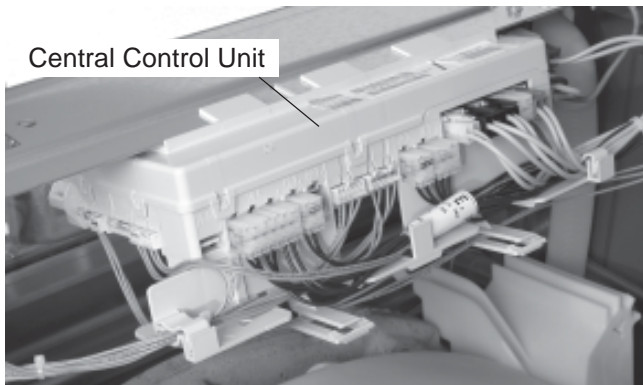

MOTOR CONTROL UNIT (MCU)

The Motor Control Unit is located inside a plastic control box located in the lower front corner of the washer cabinet. The control box is shown with the access door open.

The MCU operates the drive motor at varying speeds and direction based on inputs received by the CCU to complete the cycle selected. The MCU also monitors a tachometer on the motor to confirm that the drive motor is operating at the proper speed and direction.

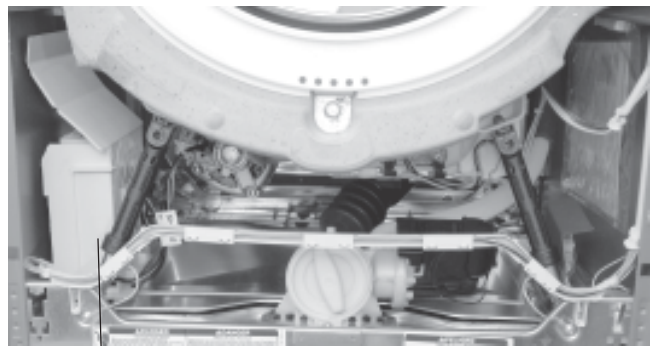

DRIVE MOTOR

The drive motor is a three-phase asynchronous induction type that operates at various speeds and direction based on input voltages and frequencies. A tachometer on the motor shaft sends a feedback signal to the Motor Control Unit indicating the rotation speed and direction.

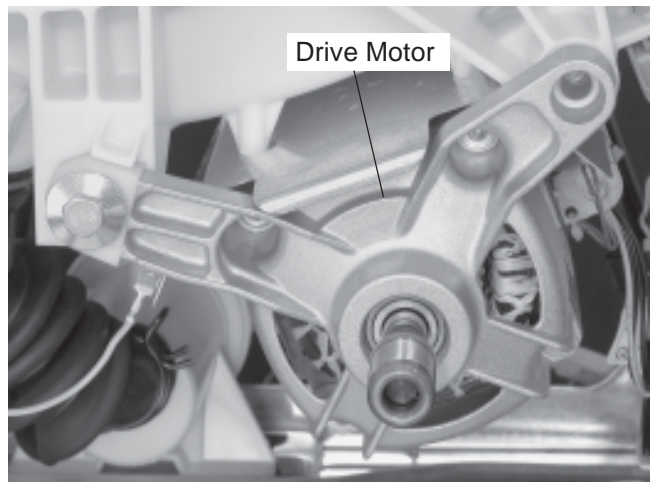

PUMP MOTOR

A separate pump/pump motor is used to drain the wash tub.

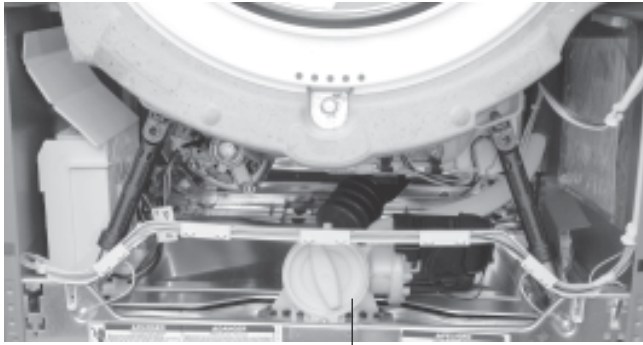

Pump Motor

The pump motor is 120 VAC and is attached directly to the pump. The pump has a cleanout filter located at the front that allows for the removal of large objects that may have passed from the basket.



Large Object Filter

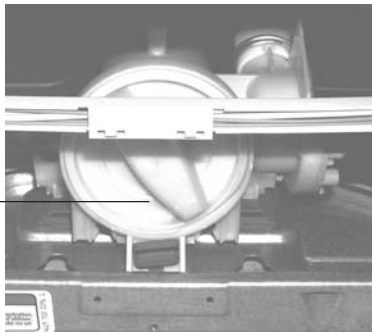

ECO VALVE

The washer has a specially designed floating (ball) valve that closes during the wash portion of the cycle so that 100% of the water and detergent mixture is used on the wash load. The Eco Valve insures that no water or detergent is wasted.

Floating (Ball) Valve

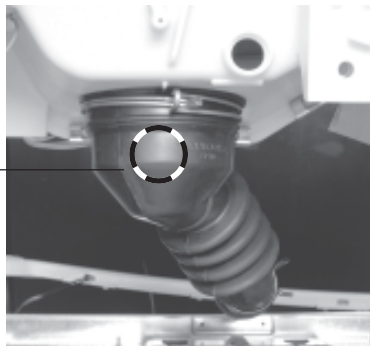

SUSPENSION SYSTEM

The wash tub is held in position with four shock absorbers attached to the bottom four corners of the tub assembly. In addition, the wash tub is suspended from the top frame of the washer with two springs attached to the sides of the unit.

Stability for this suspension system is provided by three concrete counterweights. Two are located at the front of the wash tub. One is positioned at the back of the tub. These counterweights eliminate the need for the traditional balance ring.



Top Front Counterweight

Spring

Spring

Bottom Front Counterweight
Front Shock Absorbers

HEATING ELEMENT & TEMPERATURE SENSOR

A heating element is used to increase the water temperature during certain wash cycles. The temperature sensor is used with the heater to monitor water temperature in the tub.

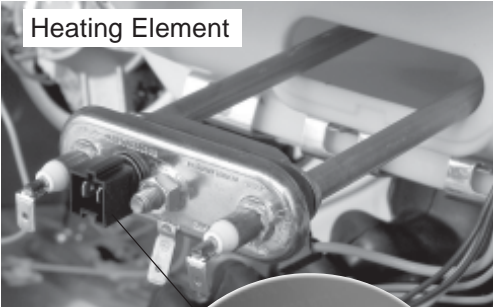

Temperature Sensor



DOOR LOCK/SWITCH ASSEMBLY

The Door Lock/Switch Assembly is located on the right side of the door opening.

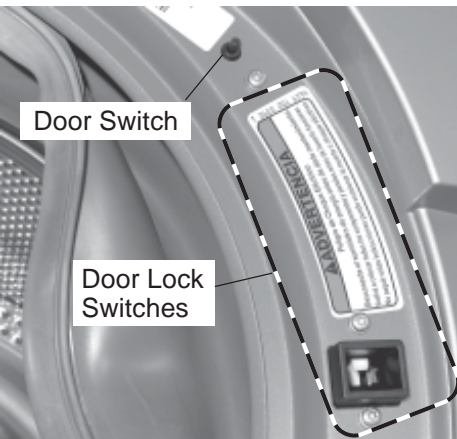

The assembly contains a solenoid operated latching mechanism that will electrically lock the door during a wash cycle.

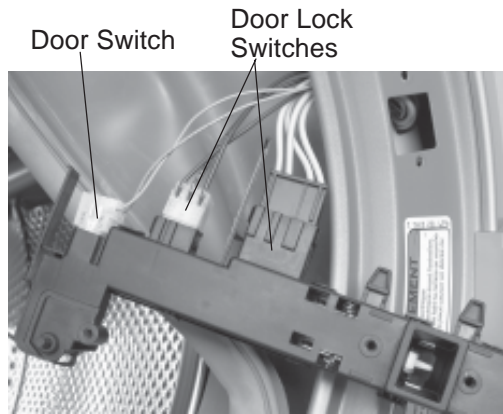

INTERLOCK SWITCHES

The front and rear interlock switches are located immediately behind the toe and rear panels of the washer. The switches provide a grounding circuit to the drive motor and heating element when either panel is removed for servicing.

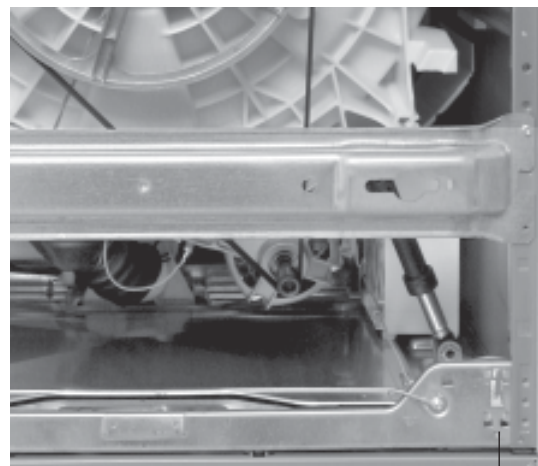

Rear Interlock Switch

WASHER USE

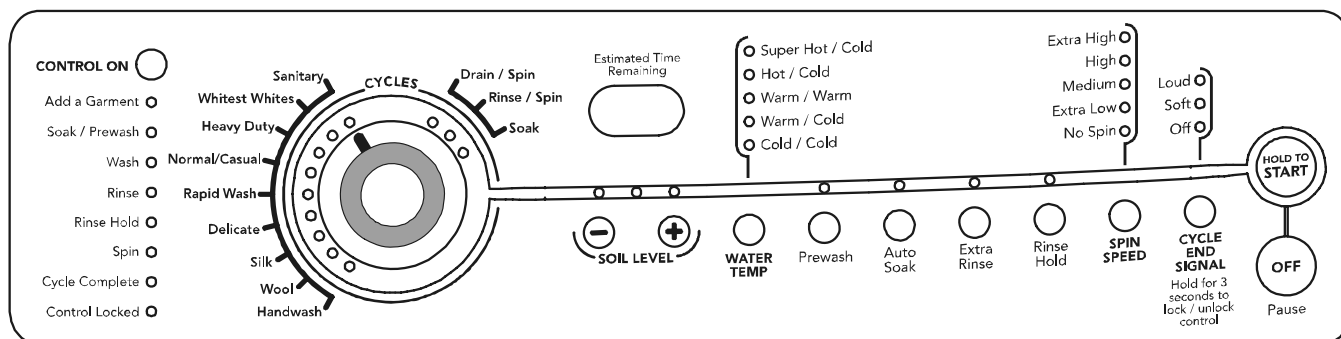

NOTE: The panel shown above may be different from that of your model.

Starting Your Washer

⚠ WARNING



Fire Hazard

Never place items in the washer that are dampened with gasoline or other flammable fluids.

No washer can completely remove oil.

Do not dry anything that has ever had any type of oil on it (including cooking oils).

Doing so can result in death, explosion, or fire.

WARNING: To reduce the risk of fire, electric shock, or injury to persons, read the IMPORTANT SAFETY INSTRUCTIONS before operating this appliance.

The following is a guide to using your washer. Please refer to specific sections of this manual for more detailed information. Do not store laundry additives on the top surface of this washer. Vibration is normal during operation.

Using the Proper Detergent

Use only High Efficiency detergents. The package for this type of detergent will be marked "HE" or "High Efficiency." This wash system, along with less water, will create too much sudsing with a regular non-HE detergent. Using regular detergent will likely result in washer errors, longer cycle times and reduced rinsing performance. It may also result in component failures and noticeable mold or mildew. HE detergents are made to produce the right amount of suds for the best performance. Follow the manufacturer's instructions to determine the amount of detergent to use.



Use only HE High Efficiency detergent.

First Wash Cycle Without Laundry

Before washing clothes for the first time, if not completed during the final installation step, choose the Normal/Casual cycle and run it without clothes. Use only HE High Efficiency detergent. Use 1/2 the manufacturer's recommended amount for a medium-size load. This initial cycle serves to ensure the interior is clean before washing clothes.

For All Wash Cycles

1. Open the washer door by pulling on the handle. Sort laundry according to color and type of fabric. Place a load of sorted clothes in the washer. Do not overload washer. Overloading can cause poor cleaning.
 - The washer can be fully loaded, but not tightly packed. Washer door should close easily.
 - Mix large and small items and avoid washing single items. Load evenly.
 - It is recommended that you wash small items such as infant socks in a mesh garment bag.
 - When unloading garments, occasionally check under the rubber rim at the front of the tub for small items.
2. Close the washer door by pushing it firmly until the lock clicks. The washer door will remain locked during the wash cycle.

NOTE: After any wash cycle is completed, the door must be opened and then closed before a new cycle can begin. The door can be opened only if PAUSE/OFF is selected while the ADD A GARMENT light is glowing or if the cycle has been canceled. See ?To cancel a cycle.?
3. Open the dispenser drawer and add laundry additives to the detergent, bleach, or fabric softener compartments. Close drawer slowly to avoid spills. See ?Using the Dispenser.?
4. Turn on the washer by selecting CONTROL ON. Select one of the cycles by turning the cycle selector. The indicator light for the selected cycle will glow. When selecting a wash cycle, the preset Options, Water Temp, Spin Speed, and Soil Level for the selected cycle will glow. The display shows the estimated time remaining. The preset settings provide the recommended fabric care for the selected cycle. See ?Cycles.?
5. Select the desired Options, such as Prewash, Auto Soak, Extra Rinse and Rinse Hold. Not all options are available with all cycles. See ?Options.?

6. Select the desired Modifiers, such as Soil Level, Water Temp, Spin Speed and Cycle End Signal. Not all modifiers are available with all cycles and options. See “Modifiers.”
7. If desired, select the CYCLE END SIGNAL. The signal is helpful when you are washing items that should be removed from the washer as soon as it stops. Select LOUD, SOFT or OFF.
8. **To begin the wash cycle immediately**
Select HOLD TO START.

If you do not select HOLD TO START within 5 minutes of choosing a cycle, the washer automatically shuts off.

When the wash cycle is complete, the CYCLE COMPLETE status light glows, the door unlocks, and the wash load can be removed from the washer. The washer powers down automatically 5 minutes after the cycle is complete and the CYCLE COMPLETE light goes off. To power down the washer manually after the wash cycle is complete, select PAUSE/OFF once.

3. Push in the dispenser drawer slowly and completely (to avoid a spill).

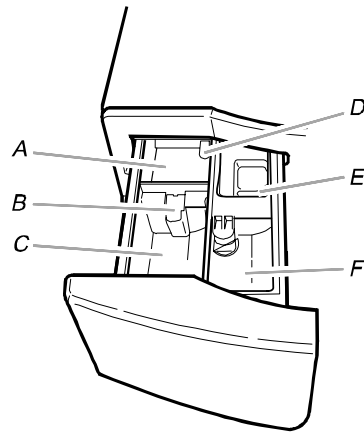

Dispenser

- A. Prewash detergent compartment
- B. Separator
- C. Main Wash detergent compartment
- D. Dispenser release lever
- E. Chlorine bleach compartment
- F. Fabric softener compartment

Using the Dispenser

Your new washer has a dispenser drawer with four separate compartments for your laundry products – two are for detergent, one is for liquid chlorine bleach, and one is for liquid fabric softener. Laundry products are diluted and dispensed automatically at the proper time during the wash cycle, making it unnecessary for you to return to the washer during the cycle to add them.

It is normal for small amounts of water to remain in the dispensers when the wash cycle is complete.

Do not put laundry additives directly into the wash tub. Always use the proper dispensers when adding laundry products.

Choosing the Right Detergent

Use only High Efficiency detergents. The package for this type of detergent will be marked HE or High Efficiency. This wash system, along with less water, will create too much sudsing with a regular non-HE detergent. Using regular detergent will likely result in washer errors, longer cycle times and reduced rinsing performance. It may also result in component failures and noticeable mold or mildew. HE detergents are made to produce the right amount of suds for the best performance. Follow the manufacturer's instructions to determine the amount of detergent to use.



Use only HE High Efficiency detergent.

To fill dispenser compartments

1. Pull out the dispenser drawer.
2. Add the desired laundry product to the proper compartment.

Prewash detergent compartment

(Letter A in Dispenser Illustration)

Add detergent to this compartment when using the Prewash option or Auto Soak. Liquid or powdered detergent may be used in this compartment. The detergent will automatically be dispensed during Prewash if the Prewash option is selected or during the soak time if Auto Soak is selected.

Using High Efficiency (HE) detergent, add ½ the recommended amount to the Prewash compartment and 2/3 the recommended amount to the Main Wash compartment.

Do not fill beyond the MAX level.

Main Wash detergent compartment

(Letter C in Dispenser Illustration)

Add liquid or powdered detergent to this compartment for your main wash cycle. The detergent separator must always be in place, either in the front or back position.

IMPORTANT: If you are using the Prewash or Soak option, powdered detergent must be used in the Main Wash compartment, since liquid detergents may seep out of the Main Wash compartment before the main wash begins.

Do not fill beyond the MAX level. Use the detergent manufacturer's recommended amount for load size.

Liquid or powdered color-safe bleach may be added to the Main Wash compartment along with the same type of detergent, liquid or powdered.

Liquid detergent: Put the separator in the front position, between the guides, as shown following. There will be no gap between the bottom of the wash cycle detergent compartment and the bottom of the separator.

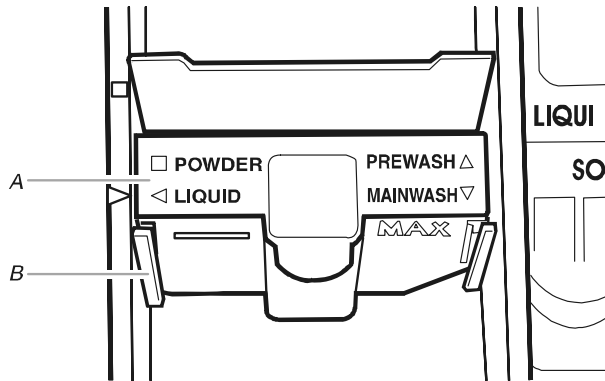

Separator in front position, between guides

A. Separator
B. Guide

Powdered detergent: Put the separator in the back position, behind the guides, as shown following. There will be a gap between the bottom of the wash cycle detergent compartment and the bottom of the separator.

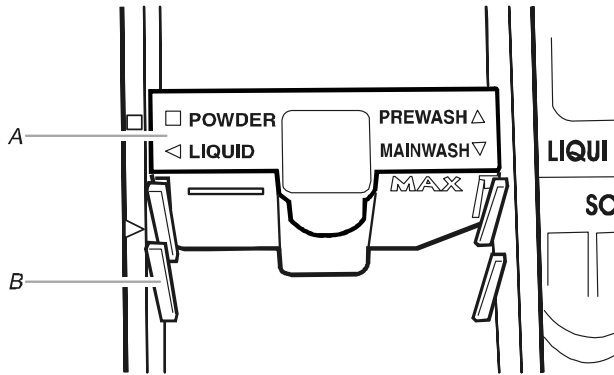

Separator in back position, behind guides

A. Separator
B. Guide

NOTE: The separator will be in the POWDER (back) position when shipped from the factory.

Chlorine bleach compartment

(Letter E in Dispenser Illustration)

Add no more than 1/3 Cup (80 mL) liquid chlorine bleach to this compartment. The bleach will be automatically diluted and dispensed at the optimum time during the first rinse after the wash cycle. This compartment cannot dilute powdered bleach.

Always measure liquid chlorine bleach. Use a measuring cup with a pour spout; do not guess.

Do not fill beyond the MAX level. Overfilling could cause severe garment damage.

Fabric softener compartment

(Letter F in Dispenser Illustration)

Add 1/4 cup (60 mL) liquid fabric softener to this compartment. Fabric softener will be automatically dispensed in the final rinse.

Do not fill beyond the MAX level.

Pausing or Restarting

1. To pause the washer at any time, select PAUSE/OFF.
2. To continue the cycle, select HOLD TO START (for approximately 1 second).

Changing Cycles, Options and Modifiers

Not all Options and Modifiers are available with all cycles. Cycles, Options and Modifiers can be changed anytime before HOLD TO START is selected.

Options and Modifiers can be changed anytime after HOLD TO START is selected and before the start of the selected Option or Modifier.

To cancel a cycle and select a new cycle

1. Select PAUSE/OFF twice.
2. Select desired cycle.
3. Select the desired OPTIONS.
4. Select HOLD TO START (for approximately 1 second) to restart the washer at the beginning of the new cycle.

To cancel a cycle

1. Select PAUSE/OFF twice.
2. The washer powers down, the door unlocks, and clothes can be removed.

NOTE: If the water level or the temperature is too high, the washer will drain automatically before the door unlocks.

To change Options or Modifiers after the cycle has started

1. Select PAUSE/OFF.
2. Select the desired OPTIONS or MODIFIERS.
3. Select HOLD TO START (for approximately 1 second) to continue the cycle.

To drain the washer manually

1. Select PAUSE/OFF.
2. Select DRAIN/SPIN.
3. Select HOLD TO START (for approximately 1 second) to begin the drain.
4. When the spin is complete, the door unlocks. Items can be removed from the washer.

Status Lights

These lights show which portion of the cycle the washer is operating. They also indicate when you can add an additional item to the wash cycle and when the controls are locked.

CONTROL ON

Add a Garment

Soak / Prewash

Wash

Rinse

Rinse Hold

Spin

Cycle Complete

Control Locked

Adding items

This washer allows an 8-minute period in which forgotten garments may be added to the load. You can add items to the washer if the ADD A GARMENT status light is glowing.

To add items

1. Select PAUSE/OFF once. The washer door unlocks, and items can be added.
2. To continue the cycle, close the door and select HOLD TO START (for approximately 1 second).
3. To unlock the door after the Add a Garment period, press PAUSE/CANCEL twice. This will cancel the Wash Cycle.

Cycle Complete

The cycle complete light stays on for 5 minutes after the cycle is complete, and then the washer shuts off.

Locking controls

The Control Lock avoids unintended use of the washer. You can also use the control lock feature to avoid unintended cycle or option changes during a cycle. When CONTROL LOCKED is lit, all buttons are disabled except for PAUSE/OFF and START. You can lock the controls while the washer is operating.

To lock the controls

Select and hold CYCLE END SIGNAL for 3 seconds.

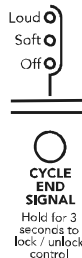

The CONTROL LOCKED status light glows.

To unlock the controls

Select and hold CYCLE END SIGNAL for 3 seconds until the CONTROL LOCKED Status light turns off.

Door Locked

When the status light glows, the door is locked.

Estimated time remaining

The cycle time varies automatically based on your water pressure, water temperature, detergent and clothes load. The cycle time will be extended if oversudsing occurs or the load is unbalanced. The SUDs routine removes extra suds and assures proper rinsing of your garments. During the unbalance routine the time displayed may pause until this activity is complete, then resume with the cycle. These routines may add up to a half-hour to the default cycle time.

Cycles

Cycles can be selected by turning the Cycle control knob to the desired cycle. Each cycle is designed for different types of fabric and soil levels.

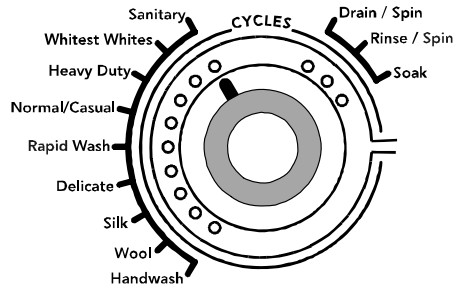

Each cycle has a preset Soil Level (cycle time), Water Temperature and Spin Speed, and may have preset options. The preset settings provide the recommended fabric care for the selected cycle.

The preset settings can be changed anytime before HOLD TO START is pressed. Not all options and modifiers are available with all cycles. (To change settings after the cycle has started, press PAUSE/OFF once, then select the desired settings. Press HOLD TO START to continue the cycle.)

Sanitary

Use this cycle to clean heavily soiled, colorfast fabrics. This cycle combines a super hot water temperature and fast-speed tumbling to help ensure the removal of heavy soils and stains. It is recommended that you set your hot water heater to 120 °F (49°C) to ensure proper performance during this cycle. The Sanitary cycle also helps eliminate 99.999% of 3 common infectious bacteria, even when no bleach is used. Extra high speed spin helps shorten drying time.

Whitest Whites

This cycle is especially designed for cleaning loads of soiled white fabrics with the addition of bleach. Hot washing temperatures assure optimal bleach activity. An additional rinse provides optimal rinse performance to avoid chlorine residues on your laundry. This cycle combines fast-speed tumbling, longer wash time, and extra high speed spin to shorten drying time.

Heavy Duty

Use this cycle to wash loads of sturdy, colorfast fabrics and heavily soiled garments. This cycle combines fast-speed tumbling, longer wash time, and extra high speed spin to shorten drying times. If the water temperature is lower than needed for this cycle, the heater will warm the water to the optimum temperature.

NOTE: Use the Heavy Duty cycle for optimal removal of organic soils such as blood.

Normal/Casual

Use this cycle to wash normally soiled cottons and linens. This cycle combines medium-speed tumbling and high-speed spin.

Rapid Wash

Use this cycle to wash small loads of lightly soiled garments that are needed in a hurry. This cycle combines fast-speed tumbling, a shortened wash time, and extra high speed spin to shorten drying time.

Delicate

Use this cycle to wash no-iron fabrics and garments labeled “Permanent Press” or “Wrinkle Free” or that indicate using a “Gentle” cycle on the care label. This cycle combines low-speed tumbling and low-speed spin to reduce wrinkling.

Silk

Use this cycle to clean washable silk garments. (Check label instructions to make sure that garment is washable.) This cycle gently tumbles and drains without spinning to gently clean garments and minimize wrinkling. Because there is no spinning action, garments will contain a higher amount of water at the end of this cycle.

Wool

Use this cycle to clean machine washable woolen garments. (Check the care instructions to make sure that garment is washable.) This cycle features gentle tumbling and low-speed spin to provide optimum garment care.

Handwash

Use this cycle to clean hand washable and special-care garments. Similar to the way garments are hand washed in a sink, the wash action of this cycle combines periods of low-speed tumbling and soaking. Low-speed spin reduces wrinkling.

Soak

Use the Soak cycle to remove small spots of set-in stains on fabrics. This cycle provides a soak time with warm or cold water followed by drain. Extra water, a short tumbling phase for equal distribution of the laundry, and a soaking time without drum movement improve the removal of set-in stains. Drain without spin assures gentle treatment, even for delicate articles.

Rinse/Spin

Use this cycle to get a rinse and spin only. This cycle combines fast-speed tumbling and extra high speed spin. If desired, you can reduce the spin speed by selecting the speed you want from the SPIN SPEED modifier.

A Rinse/Spin cycle is useful for

- Loads that need rinsing only.
- Adding fabric softener to a load.

Drain/Spin

Use this cycle to drain your washer or to drain and spin your wash load. The spin speed is preset to extra high. If desired, you can reduce the spin speed by selecting the speed you want from the SPIN SPEED modifier.

NOTE: Loads of synthetics, delicate fabrics, hand washables, and woolens should be drained with no spin or low spin speed to avoid fabric stress.

Preset cycle settings

Each cycle has a preset Soil Level (cycle time), Water Temperature, and Spin Speed. The preset settings provide the recommended fabric care for the selected cycle. See chart.

Cycle	Soil Level (cycle time)	Water Temp	Spin Speed
Sanitary	Normal (1:55)	Super Hot/Cold	Extra High [?]
Whitest Whites	Normal (1:00)	Hot/Cold	Extra High [?]
Heavy Duty	Normal (1:15)	Hot/Cold	Extra High [?]
Normal/Casual	Normal (0:40)	Warm/Cold	High
Rapid Wash	Less soil (0:35)	Warm/Cold	Extra High [?]
Delicate	Normal (0:35)	Warm/Cold	Medium
Silk	Normal (0:26)	Cold/Cold	No Spin
Wool	Normal (0:30)	Cold/Cold	Medium
Handwash	Normal (0:30)	Cold/Cold	Extra Low
Soak	Normal (0:30)	Warm/Cold	No Spin
Rinse/Spin	Normal (0:21)	Cold/Cold	Extra High
Drain/Spin	Normal (0:11)	N/A	Extra High

[?]Spin speeds may vary on some models.

To change the preset cycle settings

Press the selector of each setting until the desired setting glows.

Normal Washer Sounds

As with any new product, you will hear sounds that you are not accustomed to. You may hear various sounds when the door is locked and unlocked, and during the washing, rinsing, and spinning process. Between changes in wash actions, there will be momentary pauses. You will hear water spraying and splashing during the wash and rinse cycles. These new sounds and pauses are part of normal washer operation.

Options

You can customize your wash by adding options to your cycle selections. You can add or change an option after starting a cycle anytime before the selected option begins. Not all options are available with all cycles.

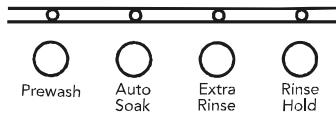

See the ?Laundry Guide? for an overview of possible options for each Wash Cycle selection.

You can select more than one option for a cycle. Some options cannot be added to some cycles; for example, Prewash cannot be added to the Rapid Wash cycle.

If an option is available with a selected cycle, the light for that option will glow when selected.

If an option is unavailable with a selected cycle, there will be a short tone, and the light for that option will not glow when selected.

Prewash

Use this option for heavily soiled loads that need pretreatment. This option adds a 15-minute prewash and drain to the main wash cycle.

NOTES:

Add detergent to the Prewash and Main Wash compartments of the Dispenser Drawer.

When using Prewash, use powdered detergent for the Main Wash detergent compartment because liquid detergent will seep into the washer during Auto Soak.

NOTE: The Prewash and Auto Soak options cannot be selected in the same cycle.

Auto Soak

Use the Auto Soak option for loads of heavily soiled cotton, linen, polyester or nylon with set-in stains. During Auto Soak, water will be added to the drum and the laundry will be equally distributed by a short tumbling phase. Laundry will then be soaked by phases without drum movement. After soaking, the washer drains without spinning.

Add detergent to both the Prewash and Main Wash compartments of the Dispenser Drawer.

Use powdered detergent for the main wash cycle because liquid detergent will seep into the washer during Auto Soak.

For cycles with Hot Wash Temperatures, the Soak temperature is set to WARM. Otherwise the Soak temperature is the same as the Wash Temperature.

The Auto Soak and Prewash options cannot be selected in the same cycle.

Extra Rinse

An extra rinse can be used to ensure the removal of detergent or bleach residue from garments. This option provides an additional rinse with the same water temperature as the first rinse.

Rinse Hold

Use this option to avoid wrinkling of your laundry when a load cannot be removed from the washer immediately. The wash cycle is paused before the final drain and spin phase so that the laundry stays in the rinse water until the cycle is continued. This provides optimal wrinkle care of your wet laundry. The door stays locked during the Rinse Hold cycle and the indicator light is flashing. Press RINSE HOLD to finish the cycle and unload the washer.

Modifiers

Preset cycle settings of Soil Level (cycle time), Water Temperature, and Spin Speed can be changed. You can change a modifier after starting a cycle anytime before the selected modifier begins. Not all modifiers are available with all cycles and options.

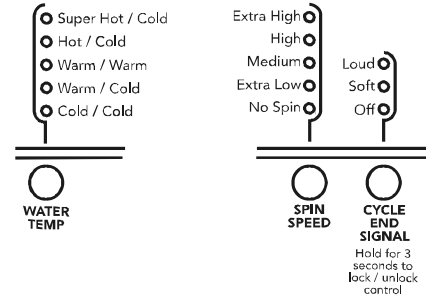

To change the water temperature, select the WATER TEMP button until the desired setting glows.

To change the spin speed, select the SPIN SPEED button until the desired setting glows.

To change the loudness of the Cycle End Signal, select (ADJUSTABLE) CYCLE END SIGNAL.

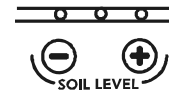

To change cycle time, select SOIL LEVEL button.

Wash/Rinse Temp

Select a water temperature based on the type of load you are washing. Use the warmest wash water safe for fabrics. Follow garment label instructions.

Warm rinses leave the loads dryer than cold rinses. Warm rinses increase wrinkling. In cold climates, a warm rinse makes the load more comfortable to handle. Cold rinses save energy.

Temperature Guide

Wash Water Temperature	Suggested Fabrics
SUPER HOT	Sturdy colorfast fabrics Heavy soils
HOT	Whites and pastels Heavy soils
WARM	Bright colors Moderate to light soils
COLD	Colors that bleed or fade Light soils

In wash water temperatures colder than 60°F (15.6°C), detergents do not dissolve well. Soils may be difficult to remove.

Automatic Temperature Control

The automatic temperature control electronically senses and maintains a uniform water temperature. Automatic temperature control regulates incoming hot and cold water. Automatic temperature control is automatically turned On when a cycle is selected. See ?Preset Cycle Settings? in ?Cycles?.

Automatic temperature control works for all wash and rinse temperature settings.

Laundry Guide

Refer to this chart for suggested load types and their corresponding cycles. Listed to the right are the options available to each of these washer cycles.

CYCLE	SUGGESTED LOAD TYPE	AVAILABLE OPTIONS			
		Rinse/Hold	Prewash*	Auto Soak*	Extra Rinse
Sanitary	Heavily soiled underwear, towels, work clothes, diapers, etc.	X	X	X	X
Whitest Whites	Heavily soiled white fabrics	X	X	X	X
Heavy Duty	Heavily soiled underwear, towels, shirts, etc.	X	X	X	X
Normal/Casual	Normally soiled blouses, shirts, overalls, etc., made of polyester, nylon, cotton, linen, or cotton blends	X	X	X	X
Rapid Wash	Lightly soiled sports wear made of cotton, polyester, nylon and cotton blends	X		X	X
Delicate	Use this cycle to wash no-iron fabrics and garments labeled Permanent Press or Wrinkle Free or that indicate using a Gentle cycle on the care label.	X	X	X	X
Silk	Fabrics made of silk identified as machine washable	X			X
Wool	Woolens with a felt-free finish, identified as machine washable	X			X
Handwash	Fabrics made of silk, special-care items marked Handwashable	X			X
Soak	Fabrics made of cotton, linen, polyester or nylon				
Rinse/Soak	Fabrics made of cotton, linen, polyester or nylon	X			X
Drain/Spin	Fabrics made of cotton, linen, polyester or nylon				

*Prewash and Auto Soak cannot be selected at the same time.

LAUNDRY TIPS

Preparing clothes for washing

Follow these recommendations to help you prolong the life of your garments.

Use only High Efficiency detergents. The package for this type of detergent will be marked HE or High Efficiency. This wash system, along with less water, will create too much sudsing with a regular non-HE detergent. Using regular detergent will likely result in washer errors, longer cycle times and reduced rinsing performance. It may also result in component failures and noticeable mold or mildew. HE detergents are made to produce the right amount of suds for the best performance. Follow the manufacturer's instructions to determine the amount of detergent to use.



Use only HE High Efficiency detergent.

Close zippers, snaps, and hooks to avoid snagging other items. Remove pins, buckles, and other hard objects to avoid scratching the washer interior. Remove non-washable trim and ornaments.

Empty pockets and turn them inside-out.

Turn down cuffs; brush away lint and dirt.

Turn synthetic knits inside-out to avoid pilling.

Tie strings and sashes so they will not tangle.

Mend tears, loose hems, and seams.

Treat spots and stains.

Stained or wet garments should be washed promptly for best results.

Mix large and small items, avoid washing single items, and load evenly.

Wash small items, such as infant socks, in a mesh garment bag. To create a balanced load it is recommended that more than one garment bag be used, and that each garment bag be filled with equal amounts of material.

NOTE: If you are washing only small items, it is recommended that more than one mesh garment bag be used, and that each garment bag be filled with equal amounts of material.

Sorting

Separate heavily soiled items from lightly soiled ones, even if they would normally be washed together. Separate lint-givers (towels, chenille) from lint-takers (corduroy, synthetics, permanent press). When possible, turn lint-givers inside-out.

Separate dark colors from light colors, colorfast items from noncolorfast items.

Sort by fabric and construction (sturdy cottons, knits, delicate items).

Unloading

Remove clothes from washer after the cycle is completed. Metal objects such as zippers, snaps, and buckles may rust if left in the washer basket for a long time.

When unloading garments, occasionally check under the gray rubber seal/bellow at the front of the tub for small items.

Loading

Loading suggestions (maximum size loads).

Heavy Work Clothes

4 jeans	2 sweatpants
4 workpants	2 sweatshirts
4 workshirts	

Towels

10 bath towels	14 washcloths
10 hand towels	

Mixed Load

3 sheets (1 king, 2 twin)	9 T-shirts
4 pillowcases	9 shorts
3 shirts	10 handkerchiefs
3 blouses	

WASHER CARE

Cleaning Your Washer

Cleaning the exterior

Use a soft damp cloth or sponge to wipe up any spills. Occasionally wipe the outside of your washer to keep it looking new. Use mild soap and water. Do not use abrasive products.

Cleaning the interior

To keep the interior of your washer clean, run the Sanitary cycle without clothes. Use $\frac{1}{2}$ of the detergent manufacturer's recommended amount of High Efficiency (HE) powdered or liquid detergent for a medium-size load.

Cleaning the door seal

Check the fold of the seal periodically for any foreign objects. To clean the seal, mix a dilute solution, using $\frac{3}{4}$ cup (177.4 mL) of liquid chlorine bleach, and 1 gal. (3.8 L) of warm tap water. Wipe the seal area with the dilute solution, using a damp cloth. Let stand 5 minutes. Wipe down area thoroughly with a dry cloth and let the washer interior air dry with door open.

IMPORTANT:

Wear rubber gloves when cleaning for prolonged periods.

Refer to the bleach manufacturer's instructions for proper use.

Cleaning the dispenser drawer

The dispenser drawer is removable for easy cleaning.

1. Unlock the dispenser drawer by pressing the Release Lever in the Prewash compartment. See Using the Dispenser. Remove the drawer.
2. Remove the inserts (the siphon from the softener and bleach compartments and the separator).
3. Wash the parts under running water.
4. Replace the inserts and return the dispenser to the drawer.

Water Inlet Hoses

Replace inlet hoses after 5 years of use to reduce the risk of hose failure. Periodically inspect and replace inlet hoses if bulges, kinks, cuts, wear or leaks are found.

When replacing your inlet hoses, record the date of replacement.

Vacation, Storage, and Moving Care

Install and store your washer where it will not freeze. Because some water may stay in the hoses, freezing can damage your washer. If storing or moving your washer during freezing weather, winterize it.

Non-use or vacation care:

Operate your washer only when you are at home. If you will be on vacation or not using your washer for an extended period of time, you should:

Unplug washer or disconnect power.

Turn off the water supply to the washer. This helps avoid unintended flooding (due to a water pressure surge) while you are away.

Slightly open door to provide ventilation.

To winterize washer:

1. Put 1 qt (1 L) of R.V.-type antifreeze in the drum.
2. Run washer on a DRAIN/SPIN cycle.
3. Unplug washer or disconnect power.
4. Shut off both water faucets.
5. Disconnect water inlet hoses from faucets and drain.

To use washer again:

1. Flush water pipes. Reconnect water inlet hoses to faucets. Turn on both water faucets.

⚠ WARNING



Electrical Shock Hazard

Plug into a grounded 3 prong outlet.

Do not remove ground prong.

Do not use an adapter.

Do not use an extension cord.

Failure to follow these instructions can result in death, fire, or electrical shock.

2. Plug in washer or reconnect power.
3. Run the washer through the Normal/Casual cycle with $\frac{1}{2}$ the manufacturer's recommended amount of HE detergent for a medium-size load, to clean the washer and remove the antifreeze, if used.

To transport the washer:

1. If washer will be moved during freezing weather, put in 1 qt (1 L) of R.V.-type antifreeze in the drum. Run washer on a DRAIN/SPIN cycle.
2. Unplug the power cord.
3. Disconnect the drain hose from the drain system and attach to rear panel clips.
4. Shut off both water faucets.
5. Disconnect the water inlet hoses from faucets, then drain the hoses and clip them to the rear panel of the washer.

IMPORTANT: Call service. Do not reuse transport bolts. Washer must be transported in the upright position. To avoid suspension and structural damage to your washer, it must be properly set up for relocation by a certified technician.

Reinstalling the washer

1. Follow the Installation Instructions to locate, level and connect the washer.
2. Run the washer through the Normal/Casual cycle with $\frac{1}{2}$ the manufacturer's recommended amount of HE detergent for a medium-size load, to clean the washer and remove the antifreeze, if used.

TROUBLESHOOTING

First try the solutions suggested here to possibly avoid the cost of a service call...

Washer displaying code message and tone sounds

FH (Water Inlet Problem no water or insufficient water supply)
Select PAUSE/OFF twice to cancel the cycle. Unplug washer or disconnect power.

Check the following:

- Are water faucets completely turned on?
- Are screens at inlet hose connection to washer clogged?
- Are water inlet hoses kinked?
- Are water inlet hoses frozen?

Plug in washer or reconnect power. Re-select cycle and press HOLD TO START. If the problem remains, call for service.

F02 (Drain Problem)

Select PAUSE/OFF twice to cancel the cycle. Unplug washer or disconnect power.

Check the following:

- Is the drain hose kinked?
- Is the drain hose frozen?
- Is the drain hose clogged?
- Is the drain hose more than 96" (2.4 m) above the floor?

SUD (Suds Routine)

When excessive suds are detected, a suds routine automatically starts. This routine removes extra suds and assures proper rinsing of your garments. SUD is displayed during rinsing and at the end of the cycle to inform you that Suds Routine was activated. Use only HE (High Efficiency) detergents.

F Variables [other than FH and F02] (Electrical Problem)

Select PAUSE/OFF twice to cancel the cycle. Select DRAIN/SPIN if there is excessive water in the washer.

Re-select cycle and press HOLD TO START. If the problem remains, call for service.

Washer won't start

WARNING



Electrical Shock Hazard

- Plug into a grounded 3 prong outlet.
- Do not remove ground prong.
- Do not use an adapter.
- Do not use an extension cord.
- Failure to follow these instructions can result in death, fire, or electrical shock.

Check the following:

- Is the power cord plugged into a grounded 3 prong outlet?
- Is the washer door firmly closed?
- Has a cycle been selected, but HOLD TO START has not been selected and held for 1 second?
- Was the door open after completion of last cycle?

Washer won't Fill, wash or rinse

Check the following:

- Is the power cord plugged into a grounded 3 prong outlet?
- Is there power at the plug? Check electrical source or call an electrician.
- Are the hot and cold water faucets turned on?
- Is the water inlet hose kinked?
- Are the water inlet valve screens clogged?

Washer stops

Check the following:

- Is the power cord plugged into a grounded 3 prong outlet?
- Is there power at the plug?
Check electrical source or call an electrician.
- Has a household fuse blown, or has a circuit breaker tripped?
Replace the fuse or reset the circuit breaker. If the problem continues, call an electrician.
- Are you using an extension cord?
Do not use an extension cord.

Washer won't drain or spin

Is the drain hose clogged, or the end of the drain hose more than 96" (2.4 m) above the floor?

Is your voltage low?

Check electrical source or call electrician. Do not use an extension cord.

Is the SUD routine active?

Cycle will complete once extra suds are removed.

Is the load balanced?

A single or bulky item may cause imbalance. Add more items or redistribute the load.

Washer makes noise or vibrates

Is the washer level?

The washer must be level. The four feet should be properly installed, and the nuts should be tightened against the washer cabinet.

As water is drained from the washer, you may hear air being pulled through the pump. This happens during the end of draining. It is normal.

Are you washing items with metal snaps, buckles or zippers?

You may hear metal items touching the washer drum. This is normal.

Is washer installed on a sturdy and solid floor?

Refer to the Installation Instructions for flooring requirements. Noise and vibration may be reduced by placing a piece of ¾" (19.1 mm) plywood underneath your washer. The plywood may extend underneath both washer and dryer to keep them at equal heights.

Washer leaks

Check household plumbing for leaks.

Dispensers clogged or leaking

Are the laundry products in the correct dispenser compartment?

Add the correct amounts of detergent, fabric softener or liquid chlorine bleach to the correct compartments. Add powdered or liquid color-safe bleach to the Main Wash compartment. Be sure to match powdered color-safe bleach with powdered detergent or match liquid color-safe bleach with liquid detergent.

Is the detergent separator in the correct position?

Separator should be in the front position when using liquid detergent and in the back position when using powdered detergent.

Washer odor

See **Cleaning Your Washer**.

Are you using HE detergent?

Use of non-HE detergent can cause a film residue which can result in odor.

Did you leave the door open after use?

This washer has a tight seal to avoid water leaks. To avoid odors leave the door open to allow the washer to dry between uses.

Load too wet

Did you use the right cycle for the load being washed?

Select a cycle with a higher spin speed.

Did you wash a single item or bulky items or have you overloaded the washer?

A single item, bulky items, or overloading may cause imbalance. Add items or try to evenly distribute your wet laundry in the drum, and start a DRAIN/SPIN cycle. If the laundry is still wet, take half of the load out of the washer and try again.

Residue or lint on load

Did you add detergent to the dispenser?

For best results, add detergent to the detergent compartment. Do not add detergent to the washer drum.

Did you sort properly?

Sort lint givers (towels, chenille) from lint takers (corduroy, synthetics). Also sort by color.

Did you overload the washer?

Do not overload the washer. The washer can be fully loaded, but not tightly packed. The wash load must be balanced. Lint can be trapped in the load if overloaded.

Check the following:

Was paper or tissue left in pockets?

Did you use enough HE detergent?

Use enough detergent to remove lint and hold it in suspension. Use only HE detergent. Follow the manufacturer's instructions to determine the amount of detergent to use.

Is your water colder than 60 °F (15.6 °C)?

Wash water colder than 60 °F (15.6 °C) may not completely dissolve the detergent.

Are you using a low speed wash cycle?

Powdered detergents may not dissolve well in a slow-speed cycle. For best results, use liquid detergent for slow-speed cycles such as Delicate, Silk, Wool, and Handwash.

Stains on load

Did you add detergent to the dispenser?

For best results, add detergent to the detergent compartment. Do not add detergent to the washer drum.

Did you use enough HE detergent?

Use enough detergent to remove soil and hold it in suspension. Use only HE detergent. Follow the manufacturer's instructions to determine the amount of detergent to use.

Is there above average iron (rust) in water?

You may need to install an iron filter.

Did you properly sort the load?

Sort dark clothes from whites and lights.

Did you unload the washer promptly?

To avoid dye transfer, unload the washer as soon as it stops.

Did you use a fabric softener dispensing ball?

Dispensing balls will not operate correctly with this washer. Add liquid fabric softener to the fabric softener compartment.

Did you use powdered detergent in a low-speed cycle?

Consider using liquid detergent.

Did you use Rapid Wash on a large load?

For best results, use Rapid Wash for small, lightly soiled loads.

Load is wrinkled

Did you unload the washer promptly?

Unload the washer as soon as it stops.

Did you use the right cycle for the load being washed?

Use the Delicate cycle or another cycle with a low spin speed to reduce wrinkling.

Did you overload the washer?

The wash load must be balanced and not overloaded. Loads should tumble freely during washing.

Gray whites, dingy colors

Did you properly sort the load?

Dye transfer can occur when mixing whites and colors in a load. Sort dark clothes from whites and lights.

Was the wash temperature too low?

Use hot or warm washes if safe for the load. Make sure your hot water system is adequate to provide a hot water wash.

Did you use enough detergent, or do you have hard water?

Use more detergent for washing heavy soils in cold or hard water.

Cycle too long

Did you choose the Sanitary cycle?

The heater will be activated to provide maximum cleaning performance. Additional time will be added to the regular cycle to heat the water. This additional time will depend on the load size and the hot water inlet temperature.

Is SUD shown in the display?

Excessive sudsing has been detected and a suds routine has been started to destroy excessive suds. This routine will add time to the original cycle.

Did you wash a large load using the Quick Wash cycle?

The Quick Wash Cycle is designed for smaller load sizes (2-3 items of lightly soiled garments). If larger loads are washed using this cycle, wash time will be increased.

Did you wash a large load using a gentle cycle?

When using the Delicate, Handwash, Silk and Wool cycles you should use small loads. This ensures a gentle wash for your garments without increasing cycle times.

Did the load cause imbalance?

When too much imbalance occurs, an imbalance routine will start to redistribute the load. During the imbalance routine, the time displayed may pause until this activity is complete, then resume with the remainder of the cycle.

Door locked at end of wash cycle

Did all of the water drain out of the washer during the spin?

Select DRAIN/SPIN to remove any water remaining in the washer. The washer door will unlock at the end of the drain.

COMPONENT ACCESS

This section instructs you on how to service each component inside the Maytag Epic Front-Loading Automatic Washer. The components and their locations are shown below.

COMPONENT LOCATIONS

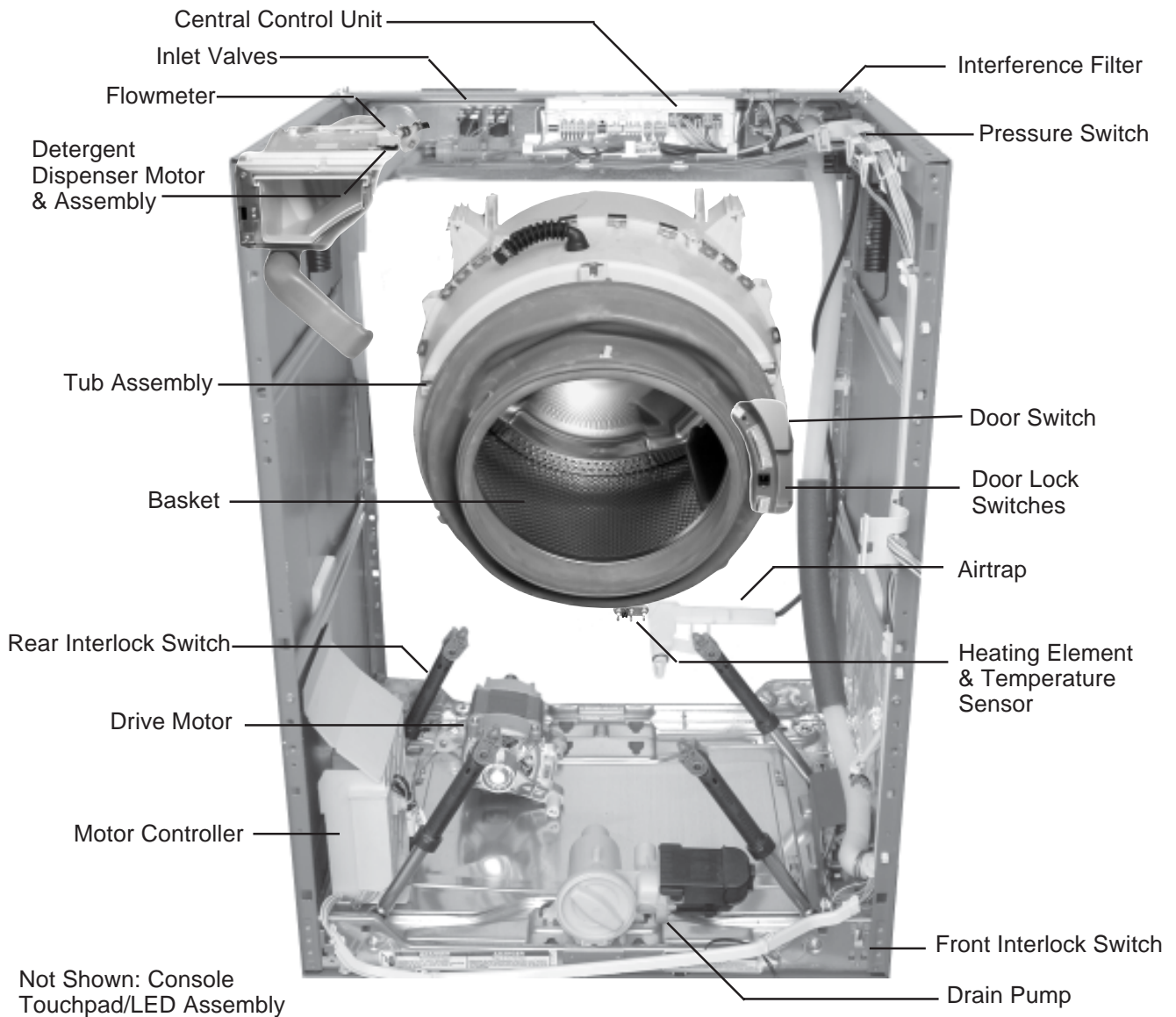

REMOVING THE CONSOLE AND THE TOUCHPAD / LED ASSEMBLY

⚠️ WARNING



Electrical Shock Hazard

Disconnect power before servicing.
Replace all parts and panels before operating.

Failure to do so can result in death or electrical shock.

1. Unplug washer or disconnect power.
2. Turn off the water supply to the washer.
3. Remove the three T-20 hex-head torx screws from the top cover of the washer.
4. Pull back on the cover and release the tabs in the console from the slots in the cover, then lift the cover off the unit.

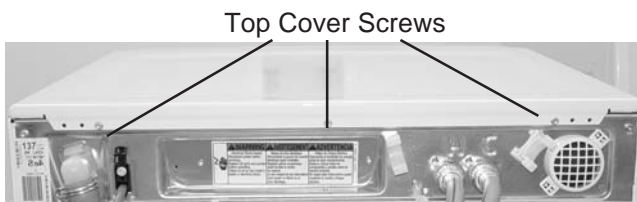
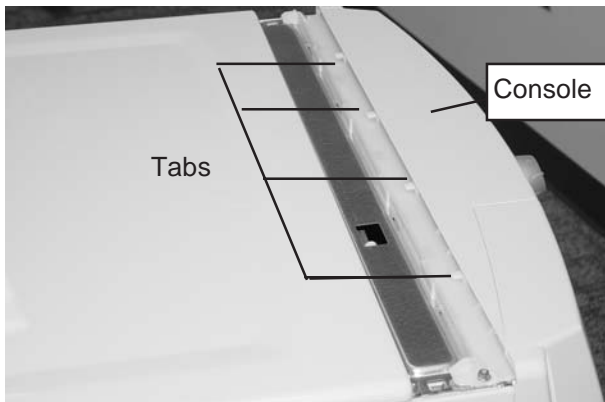

5. To remove the console:

- a) Lift the locking tab and disconnect the ribbon cable connector from the central control unit.
- b) Remove the ribbon cable from the five clips.

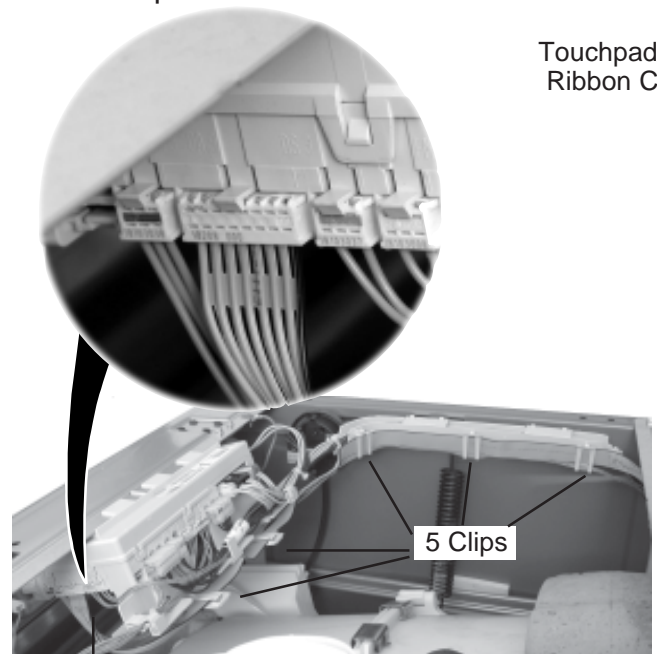

Touchpad/LED
Ribbon Cable

- c) Pull the detergent dispenser drawer out as far as it will go, then press down on the release tab, and remove the drawer from the unit.

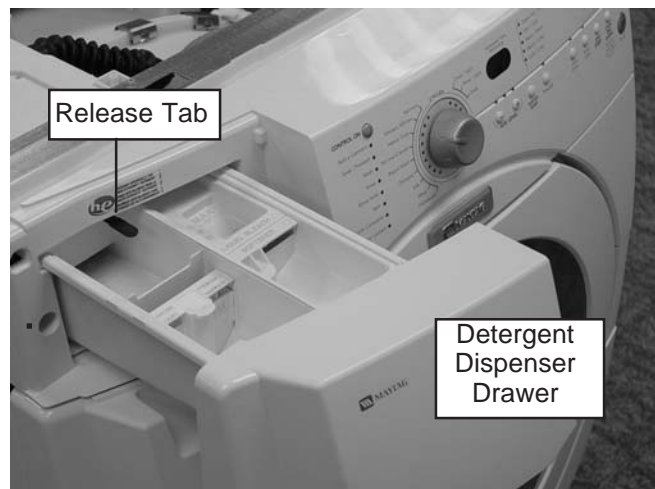

- d) Remove the T-20 torx screw from the recessed hole of the console.

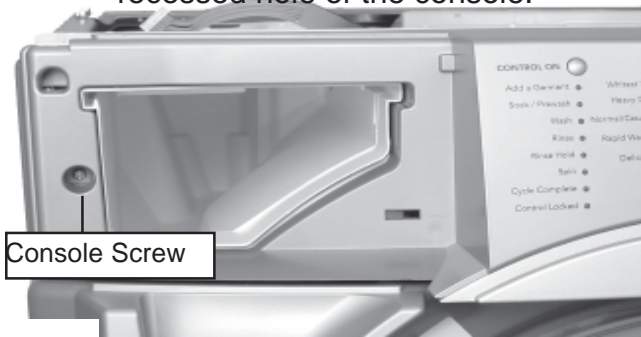

- e) Press the locking tab on the right rear side of the console, and pull out on the console to disengage the tab from its slot.

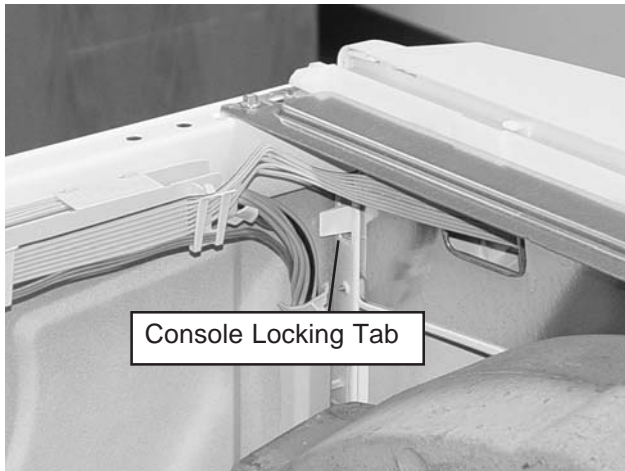

- f) Pull out at the bottom of the console and lift it to unhook the top edge from the cabinet, and remove the console.

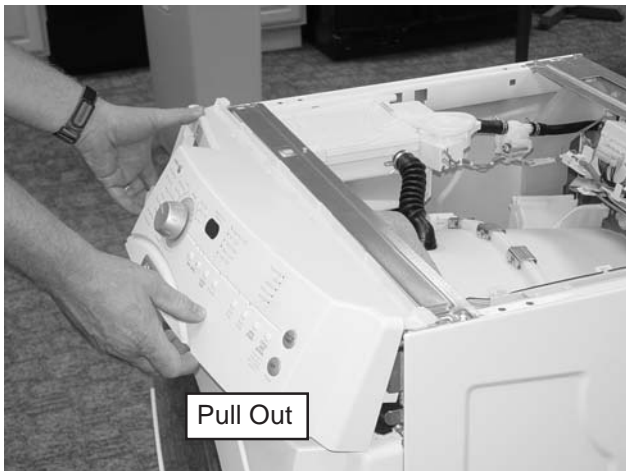

6. **To remove the touchpad / LED assembly:**

- a) Use a small screwdriver and unsnap the three top locking tabs from the touchpad/LED assembly.
- b) Starting from the right, unsnap the four lower locking tabs from the touchpad/LED assembly, and lift the assembly from the console. **NOTE:** If the push-buttons are attached to the assembly, unsnap them from the old assembly, and install them on the console at their correct locations.

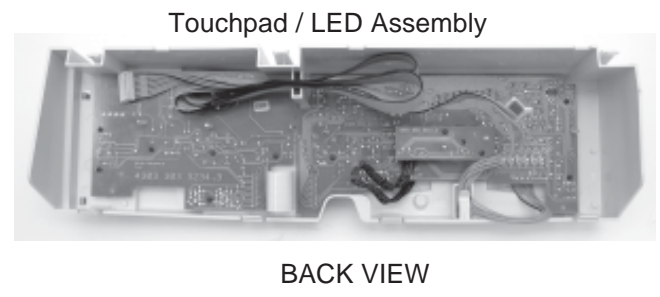
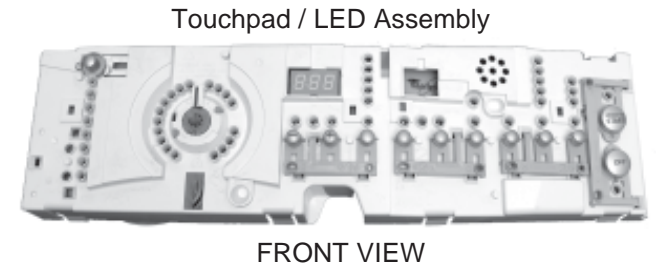
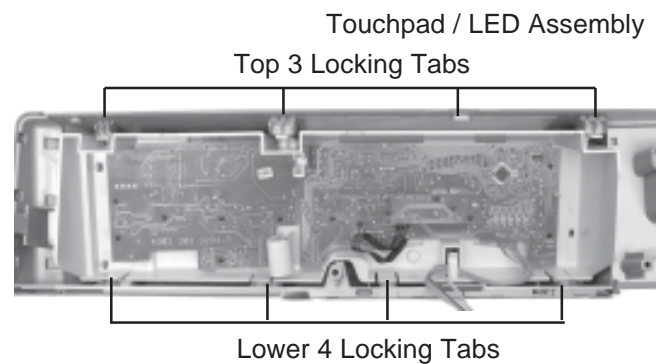

REMOVING THE DOOR LOCK / SWITCH ASSEMBLY, AND THE FRONT PANEL & BELLOWS

⚠️ WARNING



Electrical Shock Hazard

Disconnect power before servicing.
Replace all parts and panels before
operating.

Failure to do so can result in death or
electrical shock.

1. Unplug washer or disconnect power.
2. Turn off the water supply to the washer.
3. Remove the top cover and the console (see page 4-2 for the procedures).
4. Remove the three T-20 hex-head torx screws from the toe panel and remove the panel.

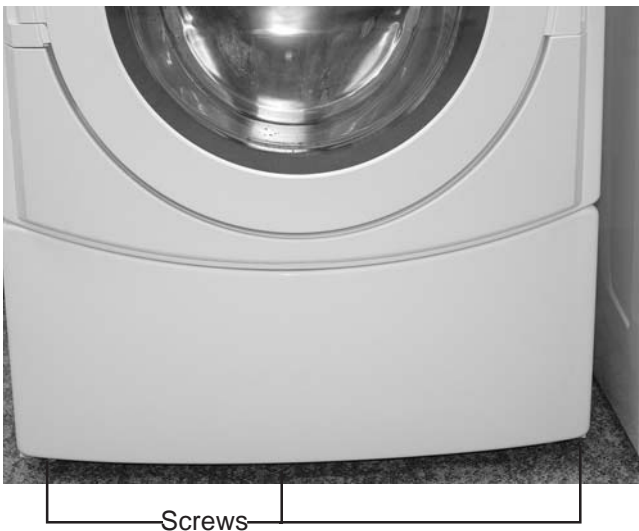

5. Open the washer door.

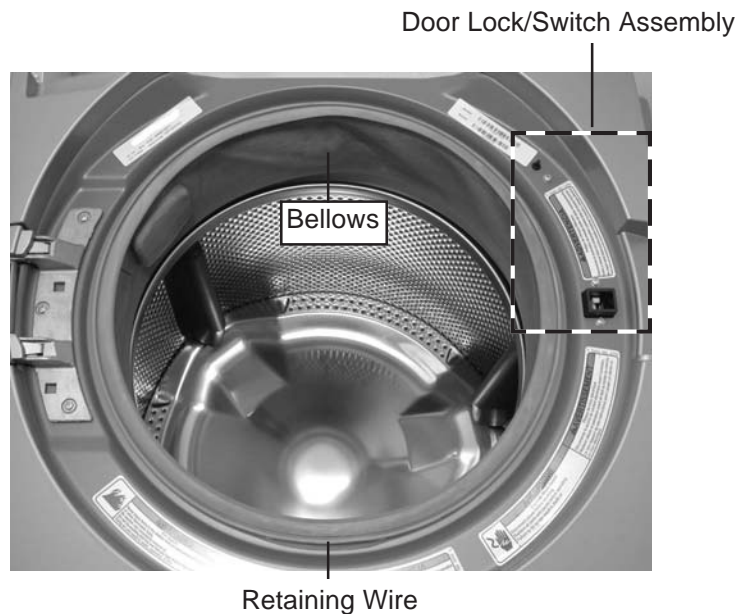

6. Starting at the bottom, use a small screwdriver, and pry the retaining wire from around the front of the bellows. **NOTE:** There is a tension spring at the bottom of the wire that can be separated to remove the wire.

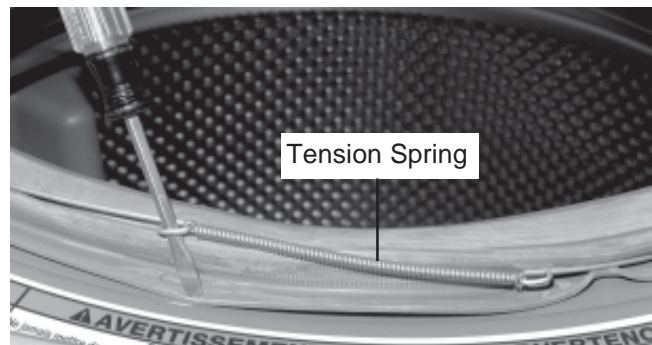

7. To remove the door lock/switch assembly:

- a) Remove the bellows retaining wire (refer to steps 5 and 6 for the procedure).
- b) Pull the bellows out and remove the three T-20 torx screws and flat washers from the door lock/switch assembly.

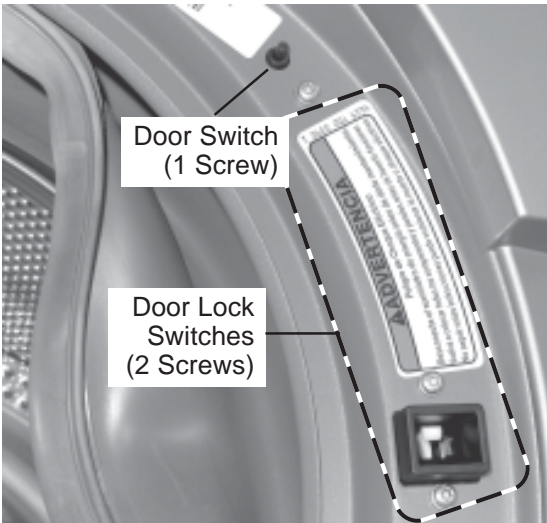

- c) Push the switch assembly out of the front panel and then slide the assembly tabs from the connector holder.

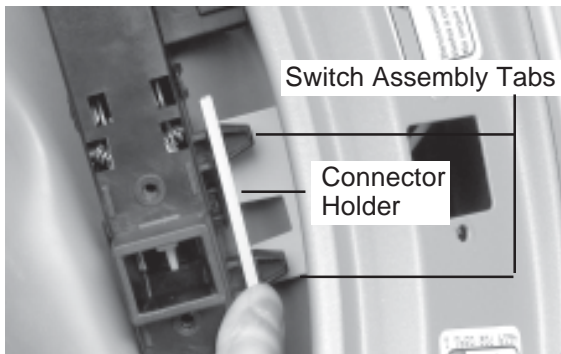

- d) Disconnect the three wire connectors from the switch terminals and remove the assembly.

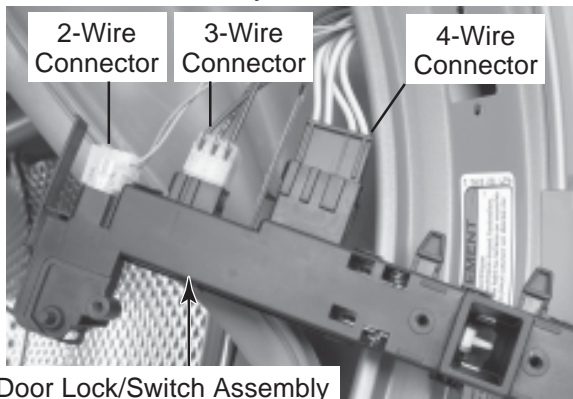

8. To remove the front panel and bellows:

- a) Remove the top cover and the console (see page 4-2 for the procedures).
- b) Remove the bellows retaining wire (refer to steps 5 and 6 for the procedure).
- c) Pull the bellows off the lip of the front panel.
- d) Remove the door lock/switch assembly (see step 7).



- e) Close the washer door.
- f) Remove the four T-20 hex-head torx screws from the top and bottom of the front panel and remove the panel from the unit.



- g) Remove the end of the dispenser tube from the bellows.

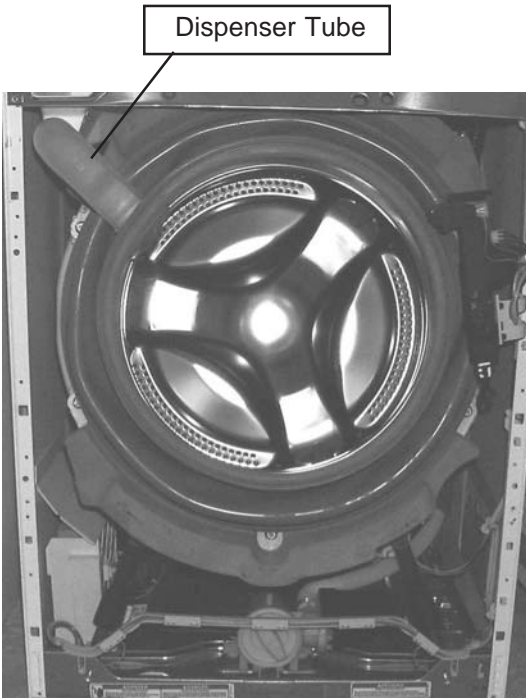

- i) Remove the bellows retainer clamp.

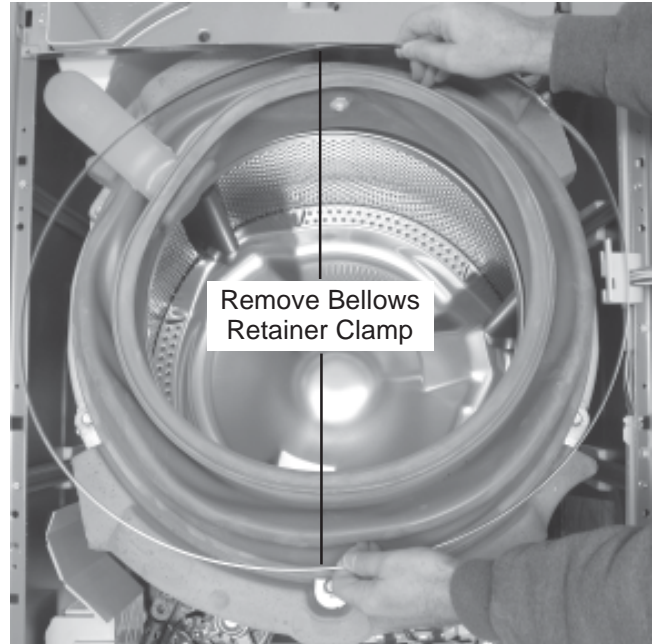

- h) Use a 7mm socket, and turn the bellows retainer clamp screw counter-clockwise until the clamp is loose enough to remove from around the bellows.



- j) Remove the bellows from the front of the tub.

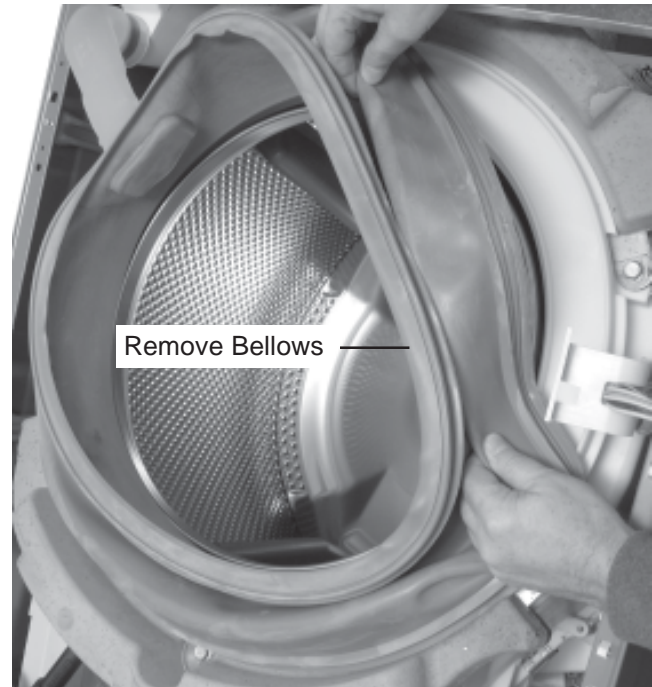

REMOVING THE FLOWMETER

⚠ WARNING



Electrical Shock Hazard
Disconnect power before servicing.
Replace all parts and panels before operating.
Failure to do so can result in death or electrical shock.

1. Unplug washer or disconnect power.
2. Turn off the water supply to the washer.

3. Remove the top cover and the console (see page 4-2 for the procedures).

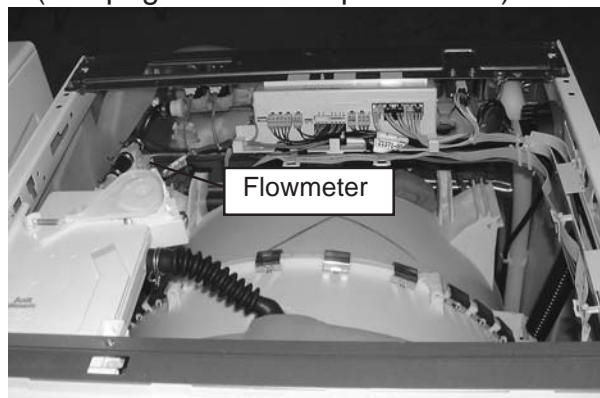

4. Loosen the two clamps and remove the two hoses from the ends of the flowmeter.
5. Disconnect the wire connector from the flowmeter.

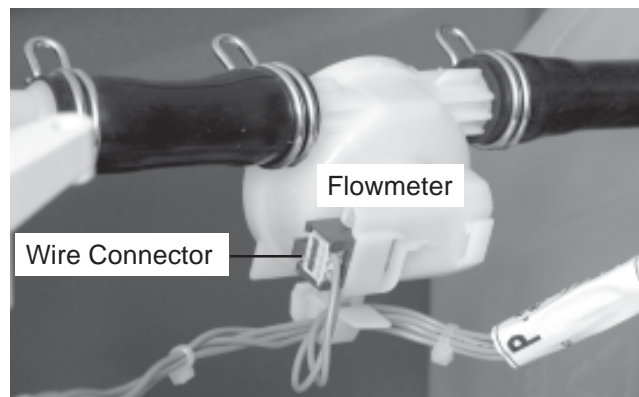

REMOVING THE DETERGENT DISPENSER MOTOR & ASSEMBLY

⚠ WARNING



Electrical Shock Hazard

Disconnect power before servicing.
Replace all parts and panels before
operating.

Failure to do so can result in death or
electrical shock.

1. Unplug washer or disconnect power.
2. Turn off the water supply to the washer.
3. Remove the top cover and the console (see page 4-2 for the procedures).

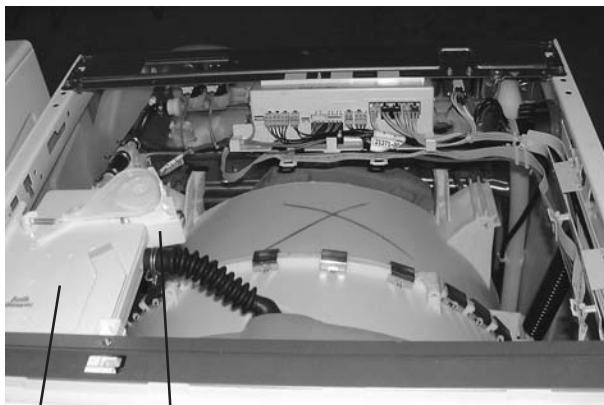

Detergent Dispenser Motor

4. To remove the detergent dispenser motor:

- a) Unhook the spring from the end of the water distribution lever.
- b) Carefully pull the cam actuator and the water distribution lever off the motor shaft, then pull the water distribution lever off the lever connection pin.

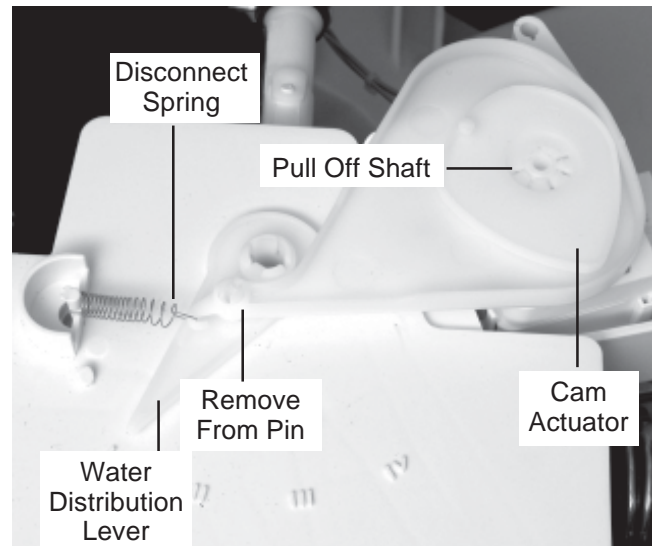

- c) Remove the two motor screws and remove the motor from the detergent dispenser.

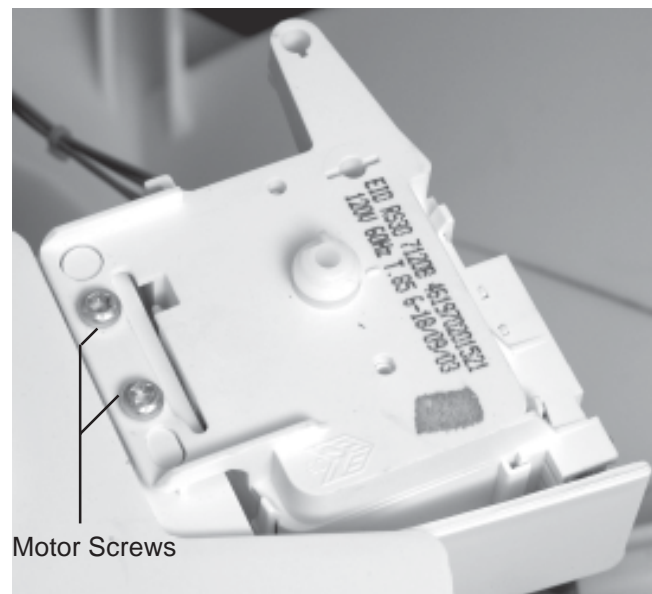

- d) Remove the motor and switch wires from the wire clip.
- e) Disconnect the two wire connectors from the motor terminals. **NOTE:** The connector with the blue stripe (motor connector) is installed above the connector with no color indicator (dispenser switch connector).

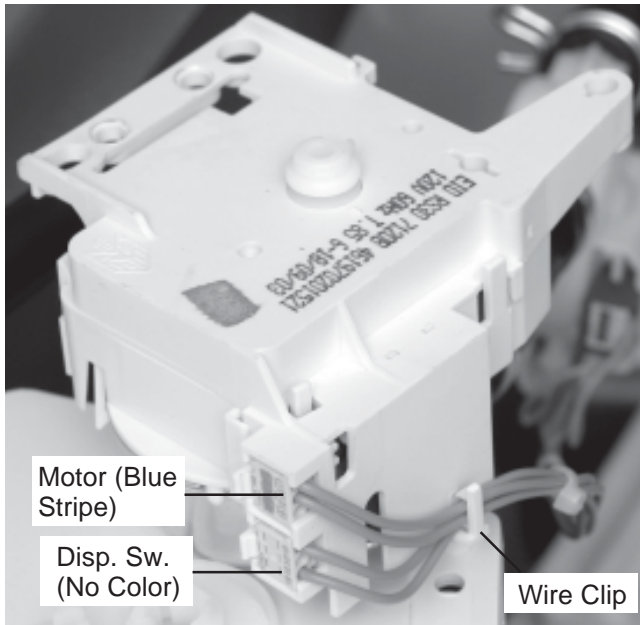

5. **To remove the detergent dispenser assembly:**

- a) Remove the front panel from the washer (see pages 4-4 and 4-5 for the procedure).
- b) Remove the detergent dispenser motor (see step 4).

- c) Use a small screwdriver and raise the locking arm so that it clears the tab. Pull the inlet hose connector and rubber o-ring out of the detergent dispenser.
- d) Loosen the clamp and pull the tub hose from the detergent dispenser.
- e) Remove the main inlet tube from the bellows.
- f) Remove the two screws from the detergent dispenser and remove the dispenser from the washer.

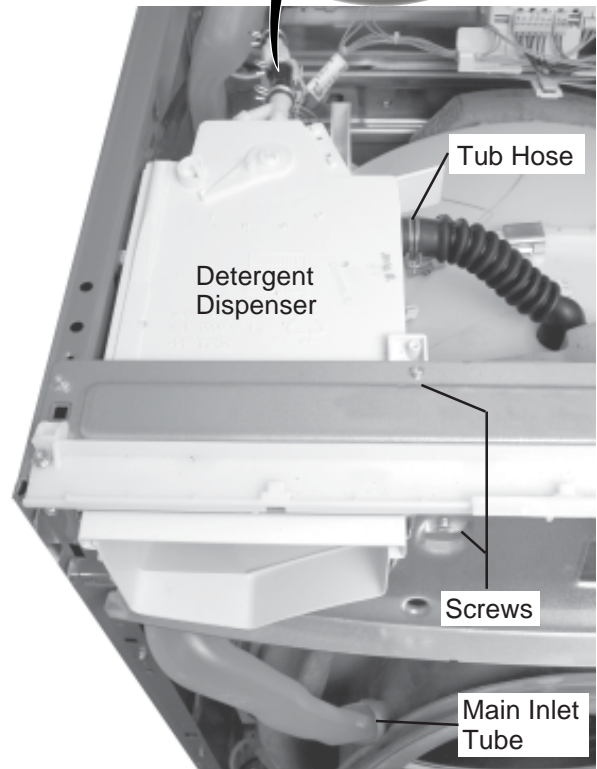
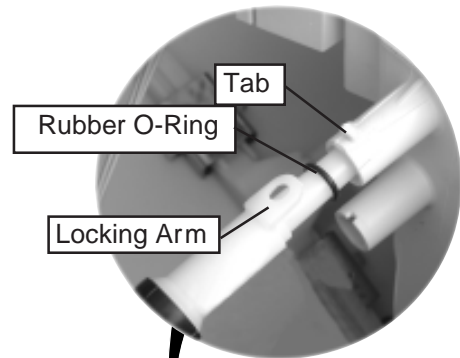

REMOVING THE INLET VALVES

⚠ WARNING



Electrical Shock Hazard

Disconnect power before servicing.

Replace all parts and panels before operating.

Failure to do so can result in death or electrical shock.

1. Unplug washer or disconnect power.
2. Turn off the water supply to the washer.
3. Remove the top cover and the console (see page 4-2 for the procedures).

Inlet Valves

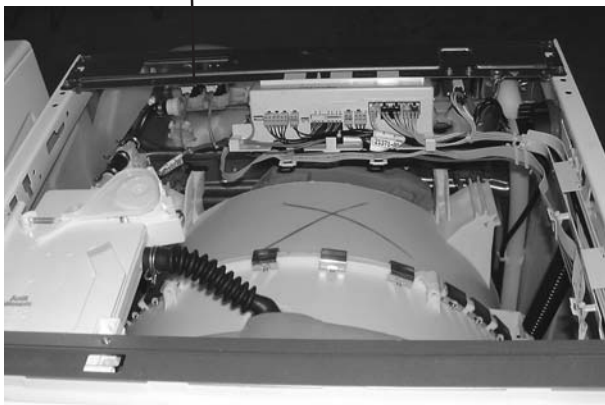

4. Disconnect the two wire connectors from the inlet valve terminals.

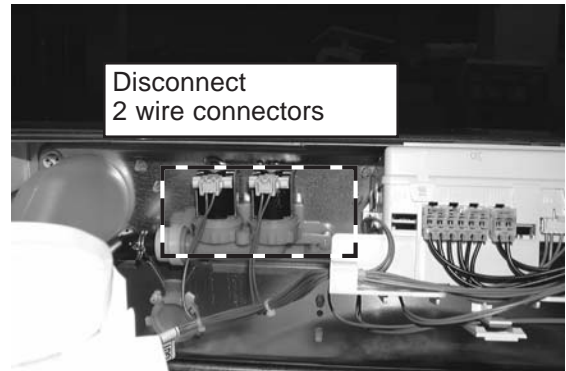

5. From behind the washer, remove the inlet valve screw, then slide the valves to the right and unhook them from the panel, and remove them.

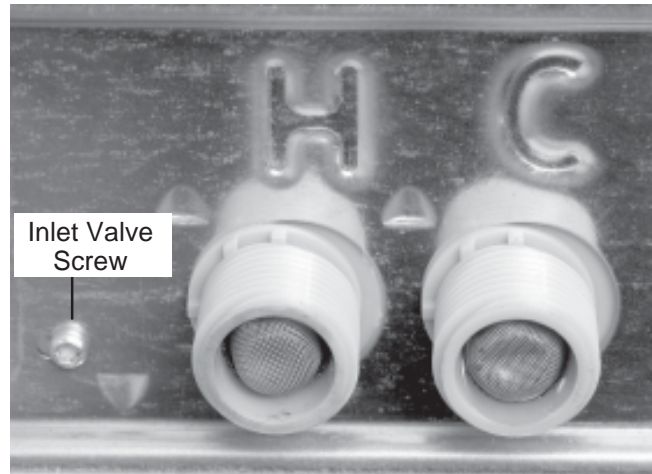

Rear Of Washer

6. Loosen the clamp and disconnect the hose from the water valves.

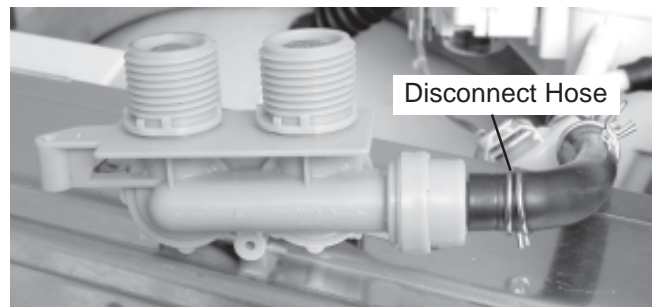

REMOVING THE CENTRAL CONTROL UNIT

⚠ WARNING



Electrical Shock Hazard
Disconnect power before servicing.
Replace all parts and panels before operating.
Failure to do so can result in death or electrical shock.

1. Unplug washer or disconnect power.
2. Turn off the water supply to the washer.
3. Remove the top cover and the console (see page 4-2 for the procedures).
Central Control Unit

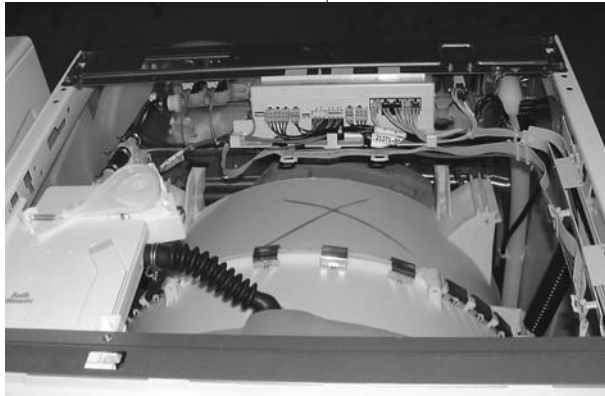

4. Remove all of the wire connectors from the central control unit (see the photo at the top of the right column). **NOTE:** Each connector has a locking arm or locking tabs that you must release to remove the connector from the unit.

5. Unlock the two wire clips and remove the wires from each of the clips (4 total).

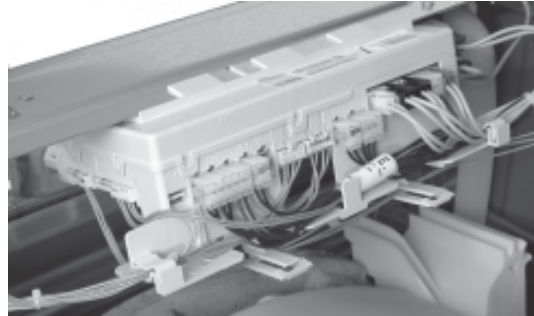

6. Pry up on the two end locking tabs with a small screwdriver and unhook the central control unit from the washer.

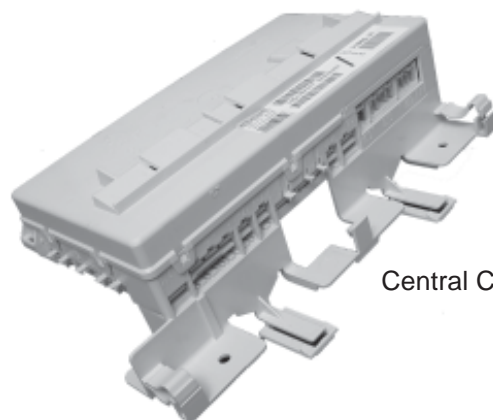
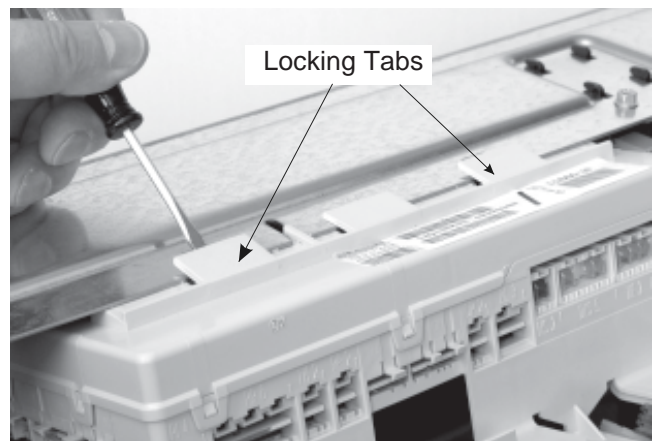

Central Control Unit

REMOVING THE INTERFERENCE FILTER

⚠️ WARNING



Electrical Shock Hazard

Disconnect power before servicing.

Replace all parts and panels before operating.

Failure to do so can result in death or electrical shock.

1. Unplug washer or disconnect power.
2. Turn off the water supply to the washer.
3. Remove the top cover and the console (see page 4-2 for the procedures).

Interference Filter

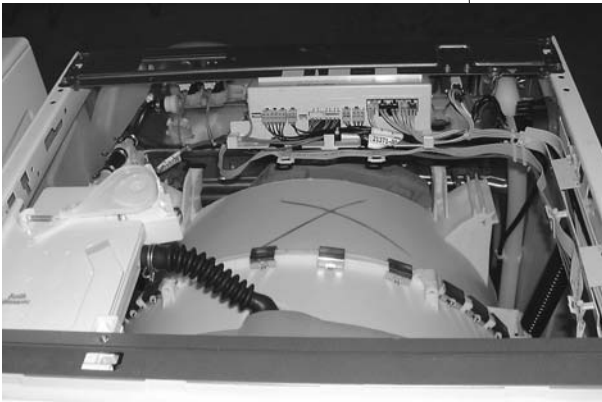

4. Disconnect the three connectors from the interference filter terminals. **NOTE:** The green 2-wire connector has a locking arm at the bottom that you must press to release the connector.
5. Remove the two T-20 hex-head torx screws from the interference filter and remove the filter from the washer.

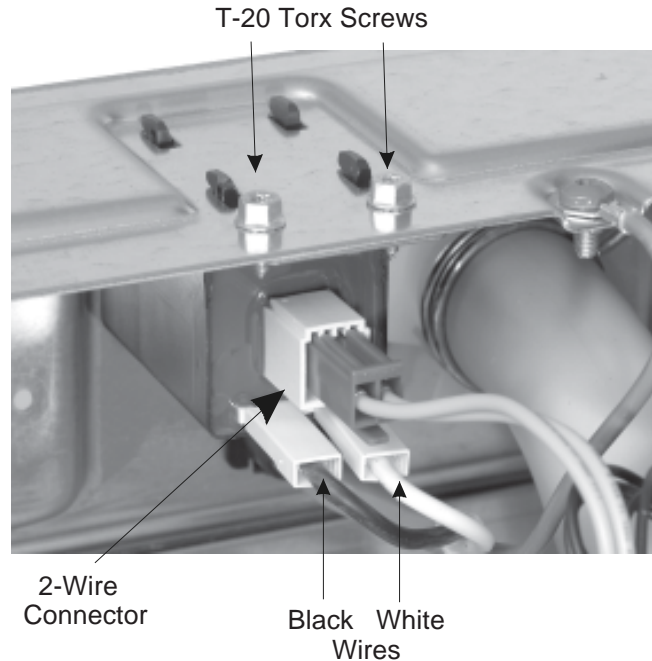

REMOVING THE PRESSURE SWITCH

⚠️ WARNING



Electrical Shock Hazard

Disconnect power before servicing.

Replace all parts and panels before operating.

Failure to do so can result in death or electrical shock.

1. Unplug washer or disconnect power.
2. Turn off the water supply to the washer.
3. Remove the top cover and the console (see page 4-2 for the procedures).

Pressure Switch

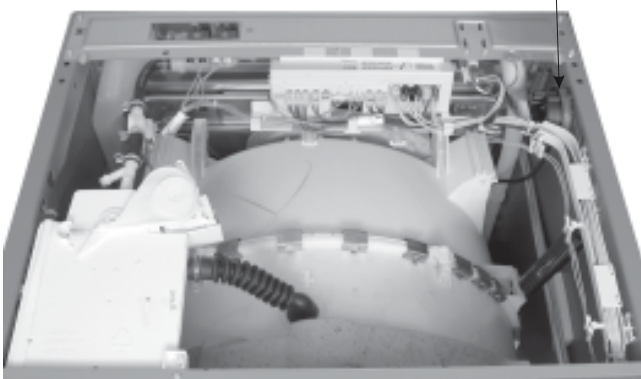

4. Pull the pressure hose off the pressure switch inlet.
5. Press on the two locking arms at the bottom of the wire connector, and pull the connector off the pressure switch terminals.

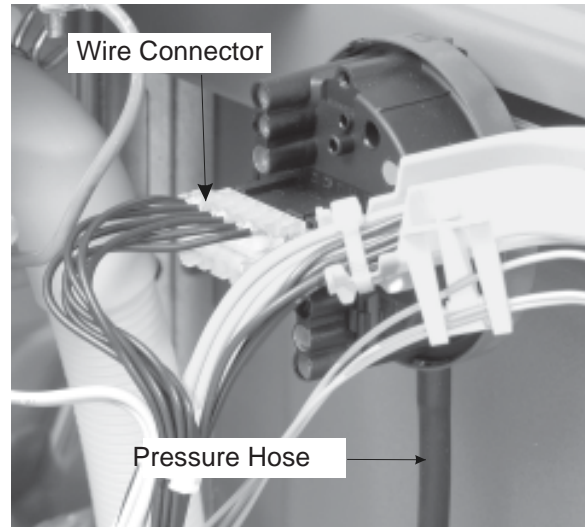

6. Pry the standoff on the wire channel out of its chassis mounting hole.
7. Turn the pressure switch 90 degree counterclockwise so that the square locking tab is aligned with the chassis cutout. Pull the tab out of the cutout, and remove the switch.

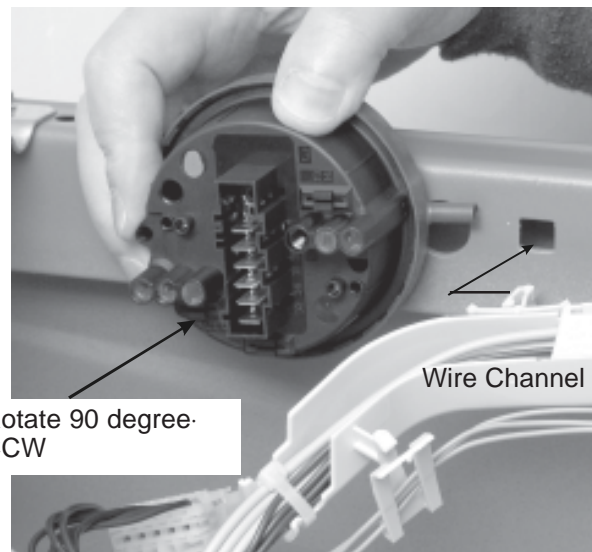

REMOVING THE MOTOR CONTROLLER

⚠️ WARNING



Electrical Shock Hazard

Disconnect power before servicing.

Replace all parts and panels before operating.

Failure to do so can result in death or electrical shock.

1. Unplug washer or disconnect power.
2. Turn off the water supply to the washer.
3. Remove the three T-20 hex-head torx screws from the toe panel and remove the panel.

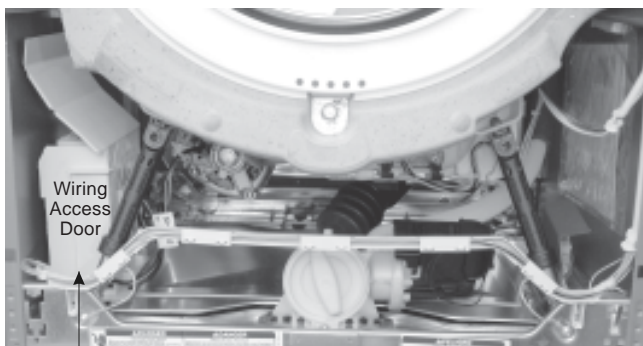

Motor Controller

4. Open the wiring access door on the front of the motor controller housing.
5. Disconnect the four wire connectors from the motor controller. **NOTE:** Each connector has a locking arm or locking tabs that you must release to remove the connector from the unit.
6. Cut the wire tie and pull the cut tie out of the slot in the standoff. **NOTE:** Be careful not to cut any of the wires in the tie.

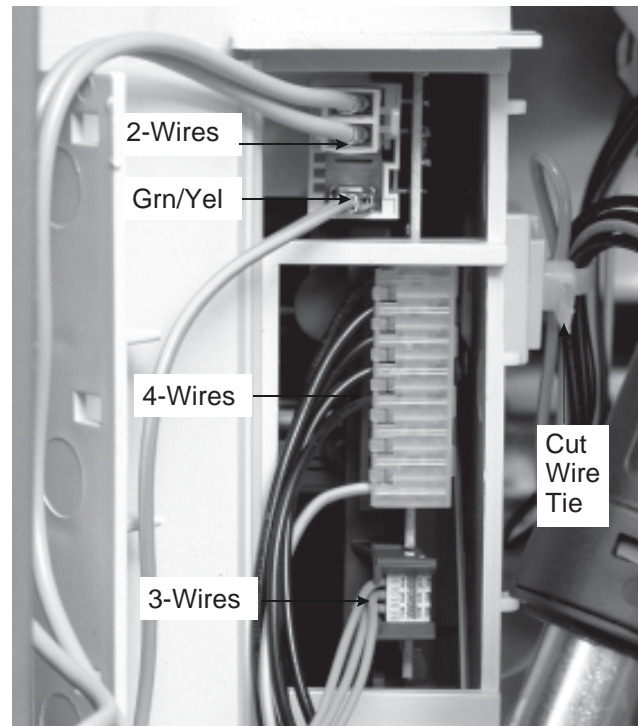

7. Lift the locking tab on the motor controller housing, and slide the housing tabs forward as far as they will go.
8. Lift the motor controller housing so the tabs are out of their chassis slots, and remove the housing from the washer.

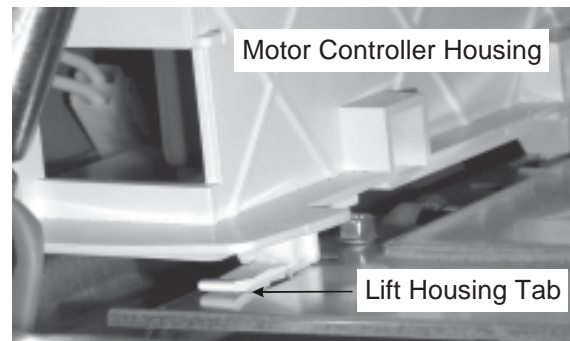

REASSEMBLY NOTE: After reinstalling the motor controller housing, slide a wire tie through the slot in the standoff and secure the wires to the standoff.



REMOVING THE TEMPERATURE SENSOR & THE HEATING ELEMENT

⚠️ WARNING



Electrical Shock Hazard

Disconnect power before servicing.
Replace all parts and panels before operating.

Failure to do so can result in death or electrical shock.

1. Unplug washer or disconnect power.
2. Turn off the water supply to the washer.
3. Remove the three T-20 hex-head torx screws from the toe panel and remove the panel.

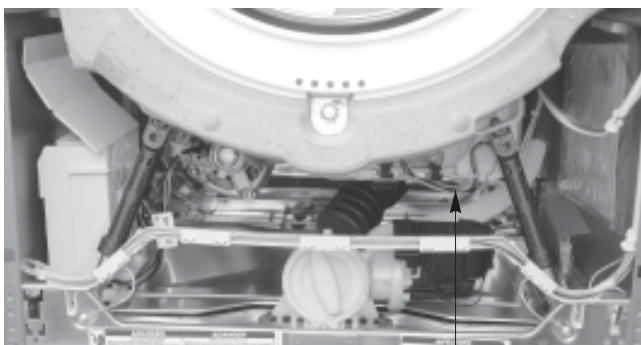

Heating Element & Temperature Sensor

4. Use a 13/32" (10 mm) socket and **loosen** the hex nut on the heating element bracket.
5. **To remove the temperature sensor:**
 - a) Disconnect the sensor connector.
 - b) Pull the sensor out of the heating element bracket hole.

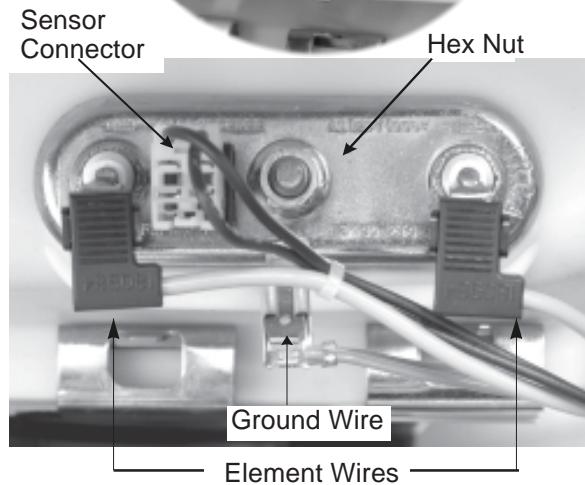
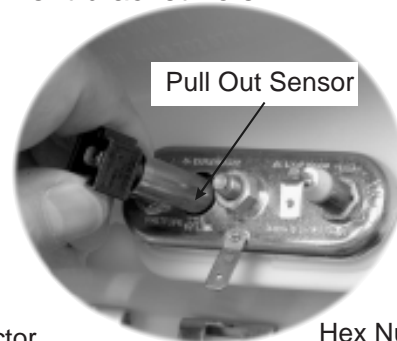

6. **To remove the heating element:**
 - a) Remove the temperature sensor (see step 5).
 - b) Disconnect the element wires and the green ground wire from the terminals.
 - c) Pull the heating element and temperature sensor out of the tub.

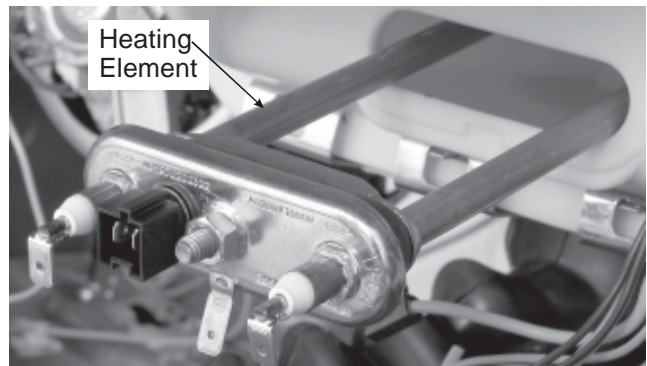

REMOVING THE DRAIN PUMP ASSEMBLY

⚠ WARNING



Electrical Shock Hazard

Disconnect power before servicing.

Replace all parts and panels before operating.

Failure to do so can result in death or electrical shock.

1. Unplug washer or disconnect power.
2. Turn off the water supply to the washer.
3. Remove the three T-20 hex-head torx screws from the toe panel and remove the panel.



Screws

Toe Panel

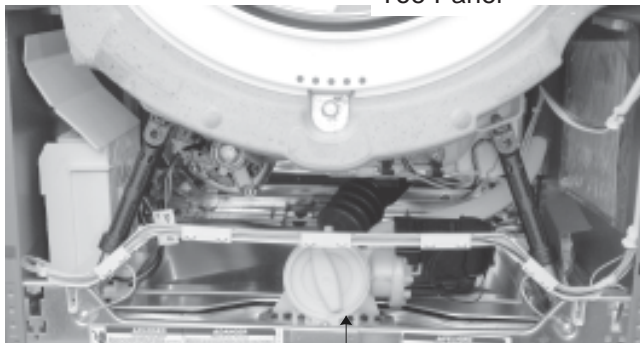

Drain Pump Assembly

4. Raise the drain pump wiring cover and disconnect the wire connector.

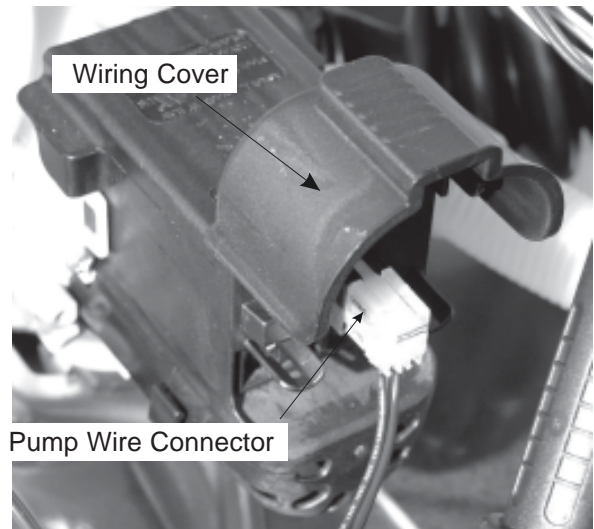

5. Loosen the clamps, and disconnect the drain and tub hoses from the drain pump.
6. Slide the drain pump forward in its mounting slots and lift it out of the washer.

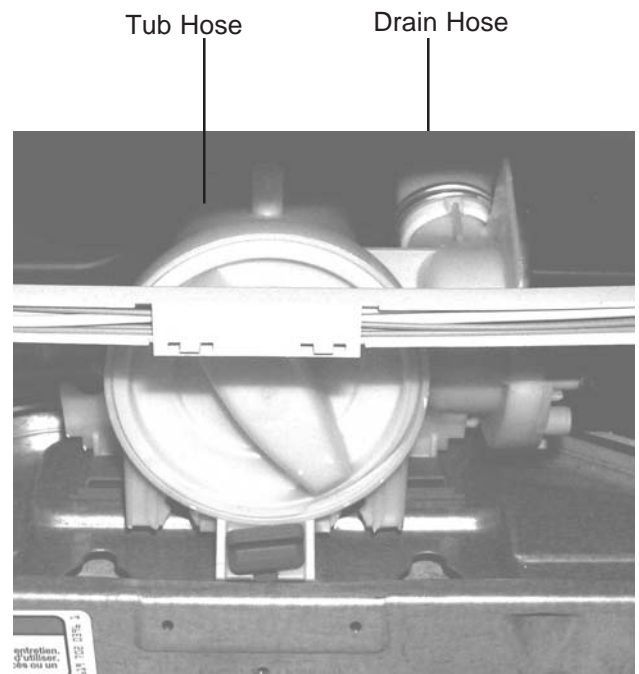

REMOVING THE AIRTRAP

⚠️ WARNING



Electrical Shock Hazard

Disconnect power before servicing.

Replace all parts and panels before operating.

Failure to do so can result in death or electrical shock.

1. Unplug washer or disconnect power.
2. Turn off the water supply to the washer.
3. Pull the washer away from the wall so that you can access the rear panel.
4. Remove the twelve T-20 hex-head torx screws from the rear panel and remove the panel from the washer.



Rear Panel Screw (1 of 12)

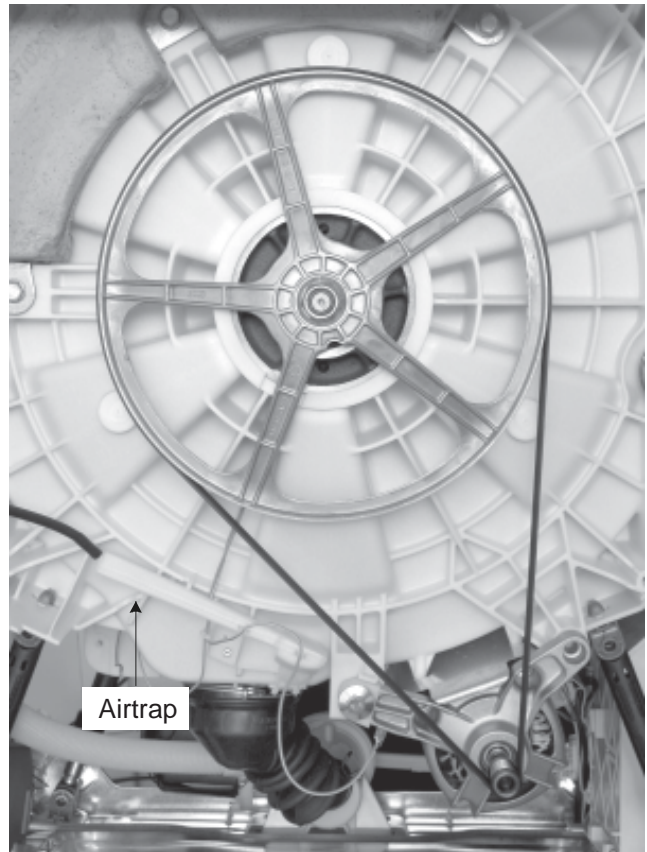

5. Pull the pressure tube off the airtrap fitting.
6. Remove the T-10 torx screws from the airtrap.
7. Press the locking arm to unlock the airtrap and pull it back and off the tub. **NOTE:** Replace the rubber o-ring if it is cracked or worn.

REMOVING AN INTERLOCK SWITCH

⚠️ WARNING



Electrical Shock Hazard

Disconnect power before servicing.

Replace all parts and panels before operating.

Failure to do so can result in death or electrical shock.

1. Unplug washer or disconnect power.
2. Turn off the water supply to the washer.
3. Depending on the interlock switch you are servicing, remove the front panel (see pages 4-4 and 4-5 for the procedure), or the rear panel (see page 4-19 for the procedure).

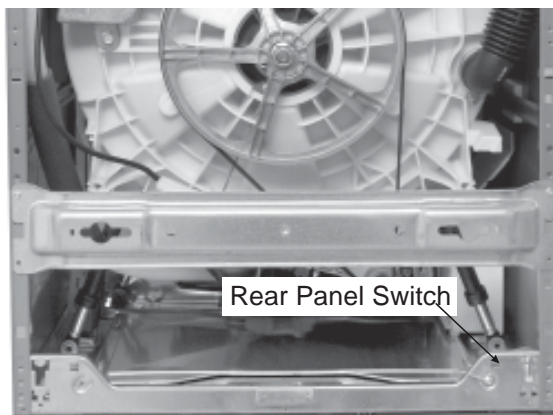
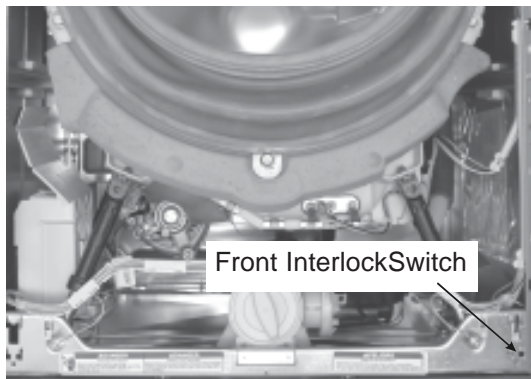

4. Press in on the locking tab. Slide the switch holder down in the chassis slots, and remove it from the chassis.

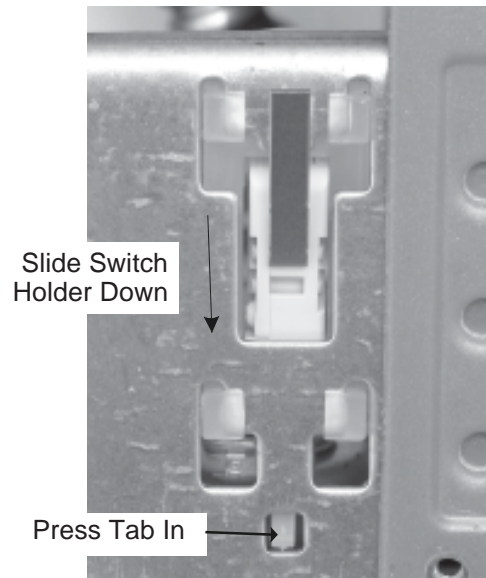

5. Remove the wires from the switch holder clip, and disconnect the wire connectors from the switch terminals. **NOTE:** The top connector has a locking tab on it.

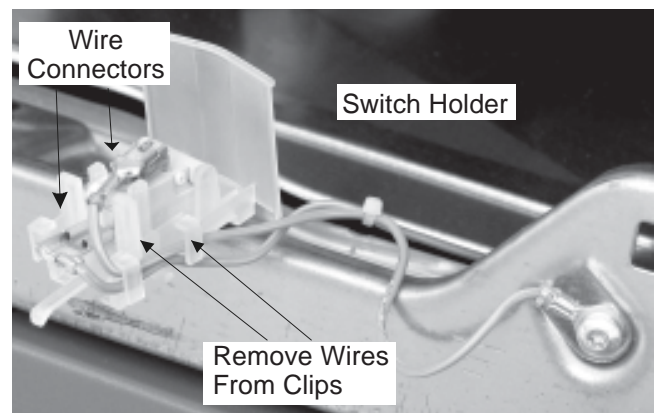

- 6. Push out on the locking tabs of the switch holder, rotate the switch up, and remove it from the holder.

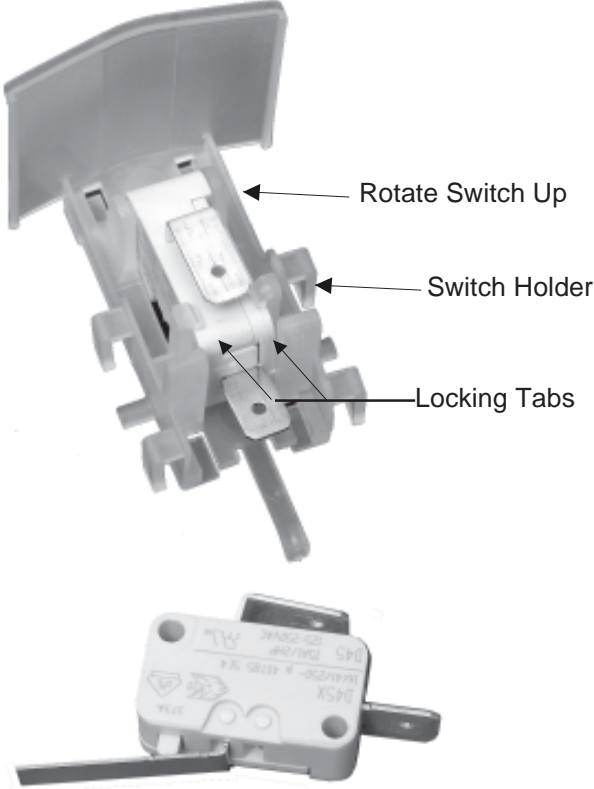

REMOVING THE DRIVE MOTOR

⚠️ WARNING



Electrical Shock Hazard
Disconnect power before servicing.
Replace all parts and panels before operating.
Failure to do so can result in death or electrical shock.

1. Unplug washer or disconnect power.
2. Turn off the water supply to the washer.
3. Pull the washer away from the wall so that you can access the rear panel.
4. Remove the rear panel from the washer (see page 4-19 for the procedure).
5. Remove the two T-20 hex-head torx screws from the bottom brace and remove the brace.

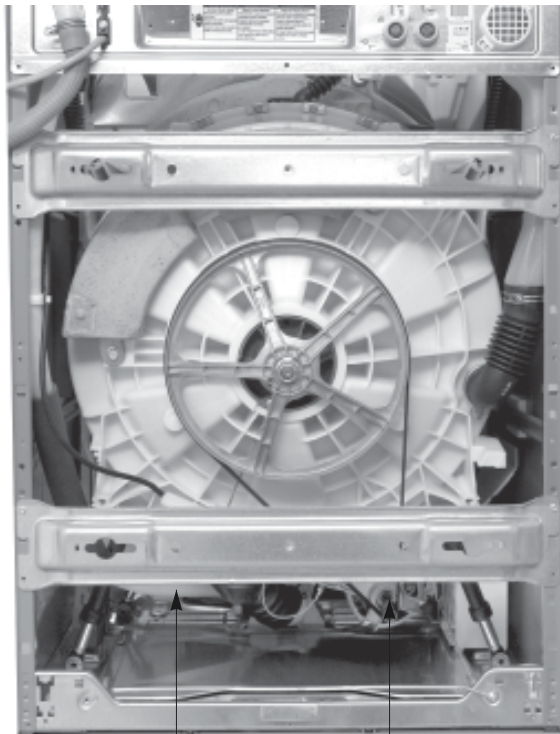

Bottom Brace Drive Motor

6. Remove the drive belt from the end of the drive motor shaft and then remove the belt from the drive pulley.

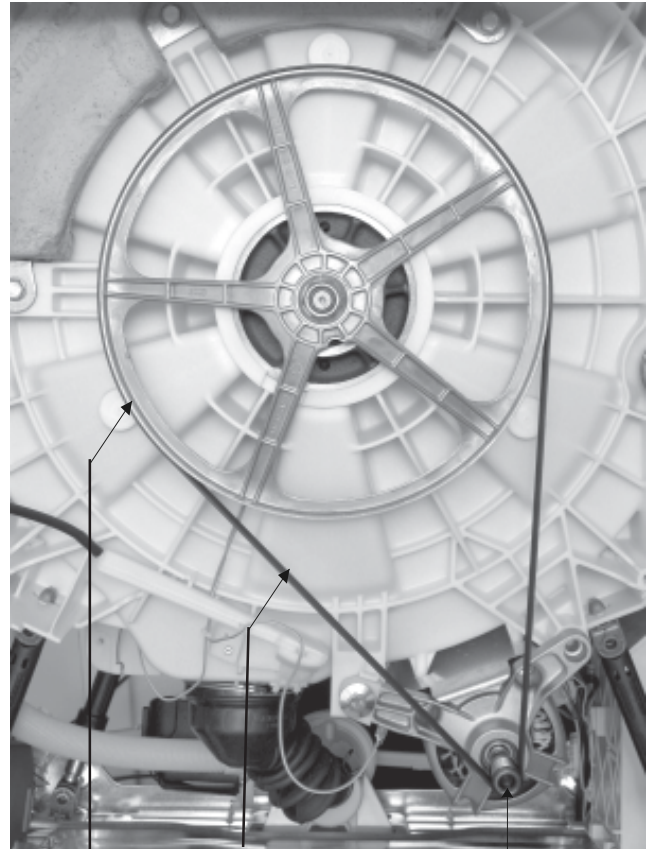

Drive Pulley Belt Drive Motor

7. Disconnect the green ground wire from the drive motor frame.
8. Remove the 1/2 inch hex-washer-head mounting bolt from the drive motor.

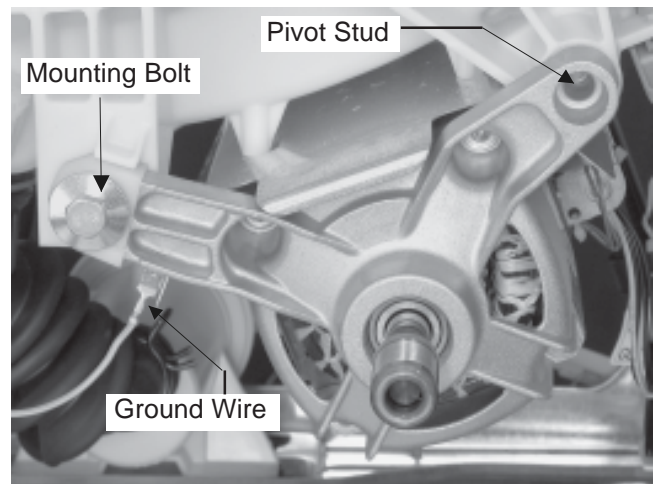

9. Pull the drive motor toward you and remove the pivot studs from the tub holes; then turn the motor around so that you can access the motor wires.

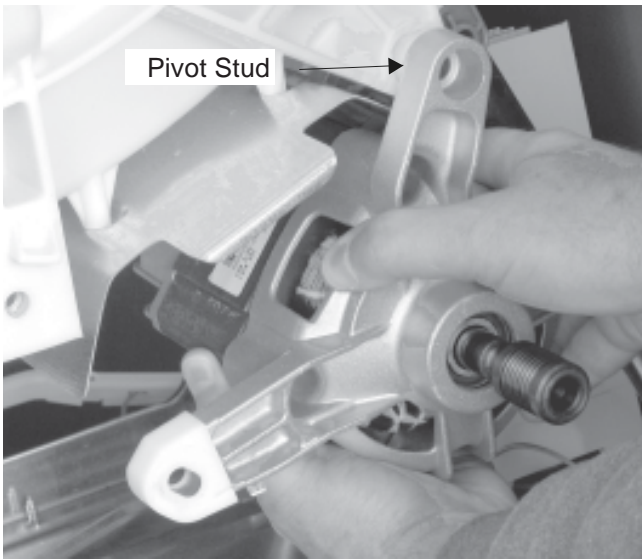

10. Push wire retainer thru motor wire retainer hole to release wire harness.
11. Press the two locking arms down and disconnect the power connector from the motor.
12. Disconnect the two green ground wires from the motor terminals.

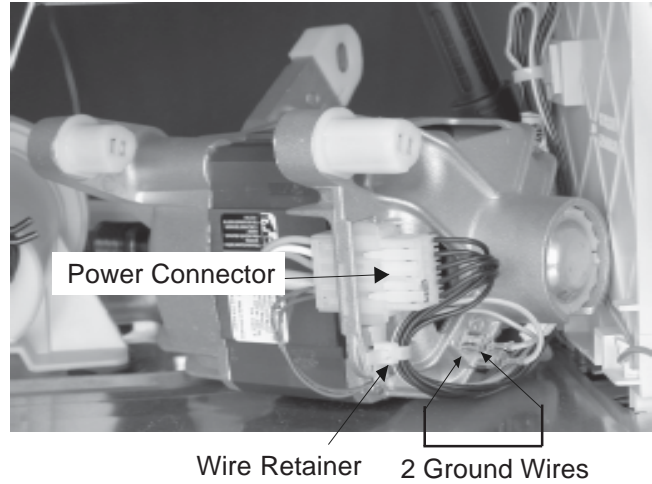

REMOVING THE TUB AND BASKET ASSEMBLY

⚠️ WARNING



Electrical Shock Hazard
Disconnect power before servicing.
Replace all parts and panels before operating.
Failure to do so can result in death or electrical shock.

⚠️ WARNING

Excessive Weight Hazard
Use two or more people to move
install washer.
Failure to do so can result in back or other injury.

1. Unplug washer or disconnect power.
2. Turn off the water supply to the washer.
3. Remove the detergent dispenser assembly (see page 4-8 for the procedure).
4. Remove the heating element & temperature sensor (see page 4-16 for the procedures).
5. Remove the drain pump assembly (see page 4-18 for the procedure).
6. Remove the airtrap from the washer (see page 4-19 for the procedure).
7. Remove the drive motor and belt (see page 4-22 for the procedure).

8. Remove the T-20 hex-head torx screws from the top (and bottom, if not already done in step 7) braces and remove both braces from the rear of the washer.

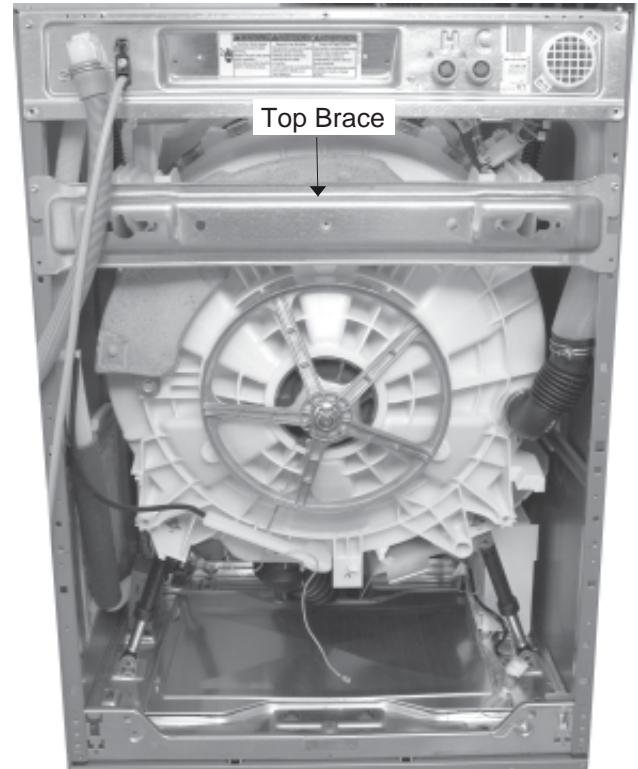

9. Loosen the clamp and pull the end of the air inlet hose from the tub.



10. Loosen the clamp and pull the end of the drain hose from the tub.

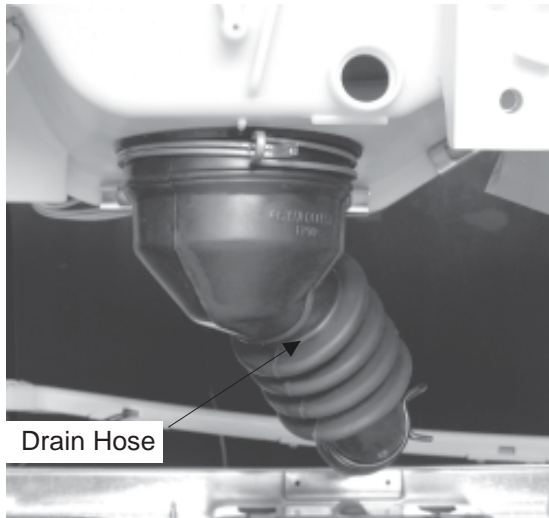

11. Remove the three 1/2 inch hex-head bolts from the rear counterweight and remove the weight.

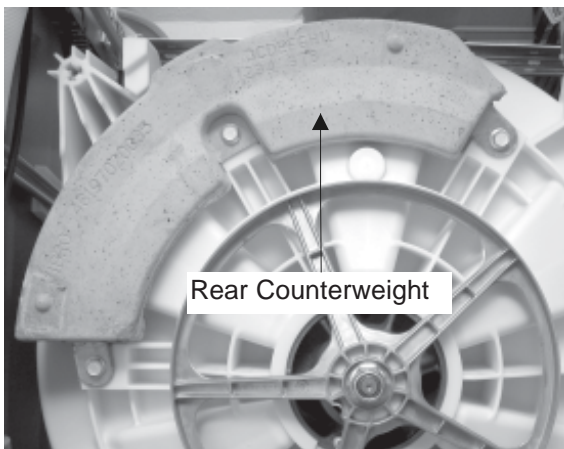

12. Remove the two rear shock absorbers from the tub. To remove a shock absorber:
- a) Pry the locking tab down with a small screwdriver.



- b) Twist the top section so the tabs align with the slots in the tub.
- c) Lower the top of the strut down through the slot, and rotate the shock absorber against the floor of the cabinet.

Continued on the next page.

13. Remove the screw from the green ground wire eyelet and remove the wires from the clips in the tub.

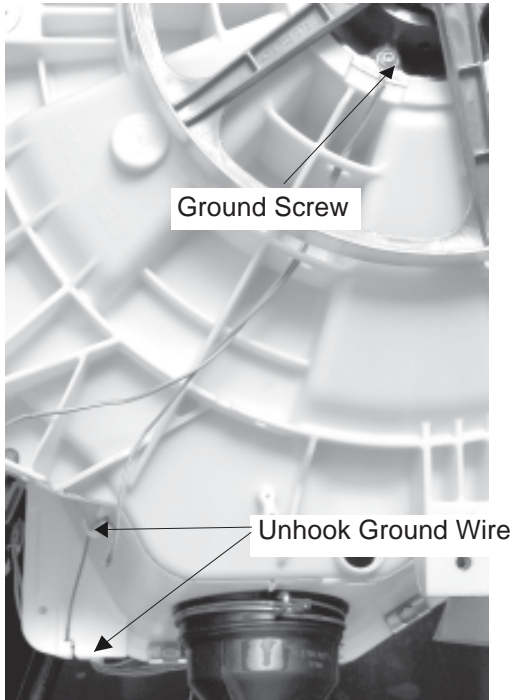

14. Remove wire ties at the front of the tub, by pulling the wire ties out of the standoffs.

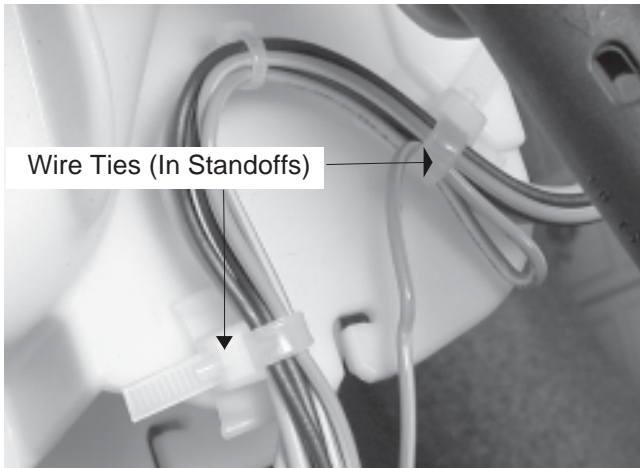

15. At the front of the washer, remove the six T-20 hex-head torx screws (total) from the top front brace and remove the brace from the washer.

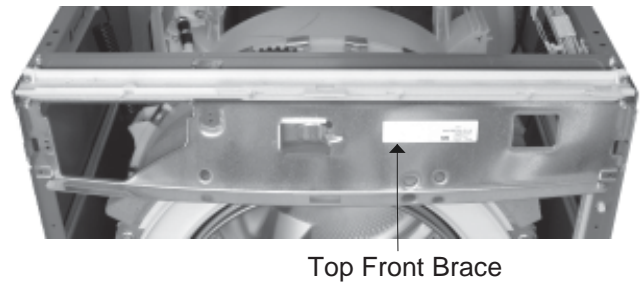

IMPORTANT NOTE: When you remove the bottom front counterweight in the following step, be sure to support it with one hand while you remove the screws with the other hand; otherwise, the weight will fall, and could cause an injury or damage the floor covering.

16. While supporting the bottom front counterweight with one hand, remove the three 1/2 inch hex-head bolts with the other hand, and remove the weight.
17. Remove the three 1/2 inch hex-head bolts from the top front counterweight, and remove the weight.



18. Using the procedure in step 13, remove the two front shock absorbers from the tub.
19. Lift the tub and basket assembly and unhook the two suspension springs, then remove the assembly from the washer, and place it front-down on a padded surface so that the back pulley faces up. **NOTE:** The suspension springs are installed in the front slots of the cabinet, as well as in the tub. Do not use the back slots; they are used with other models.

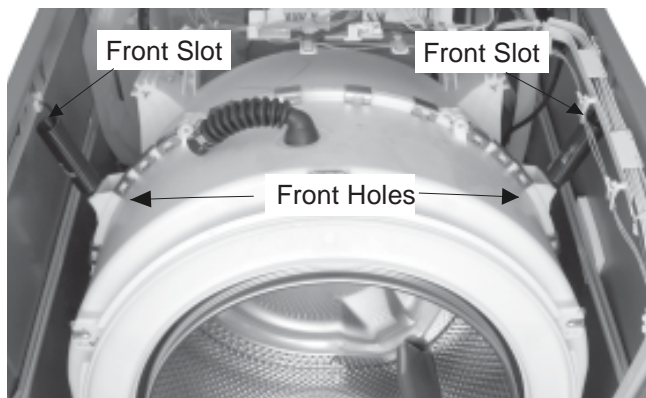

21. Mark the edges of the 23 tub clamps with a pencil so that you can reinstall the clamps in the same locations later.
22. Use a screwdriver blade, and pry off the 23 tub clamps.

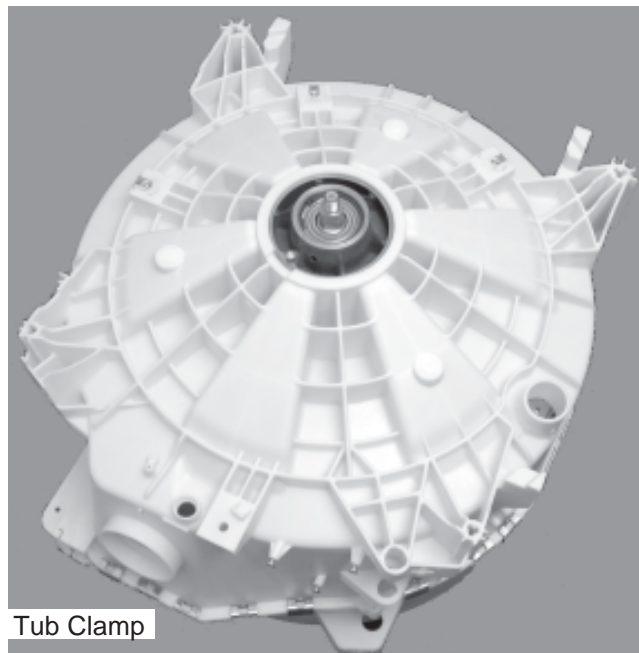

20. Remove the 15/16 inch hex-washer nut from the drive pulley and remove the pulley from the basket shaft.

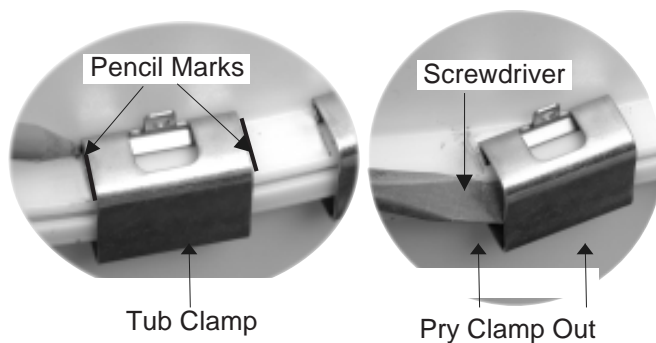
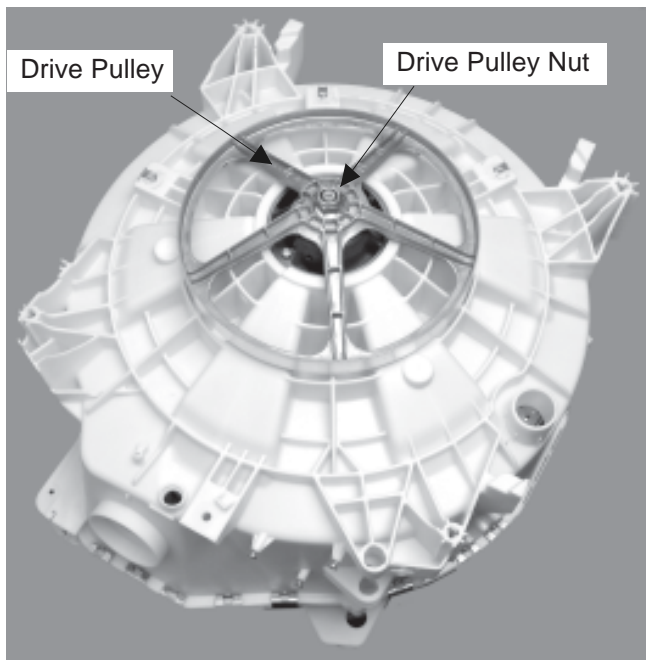

Continued on the next page.

- 23. Lift the rear half of the tub off the front half.
- 24. Lift the basket from the front half of the tub.

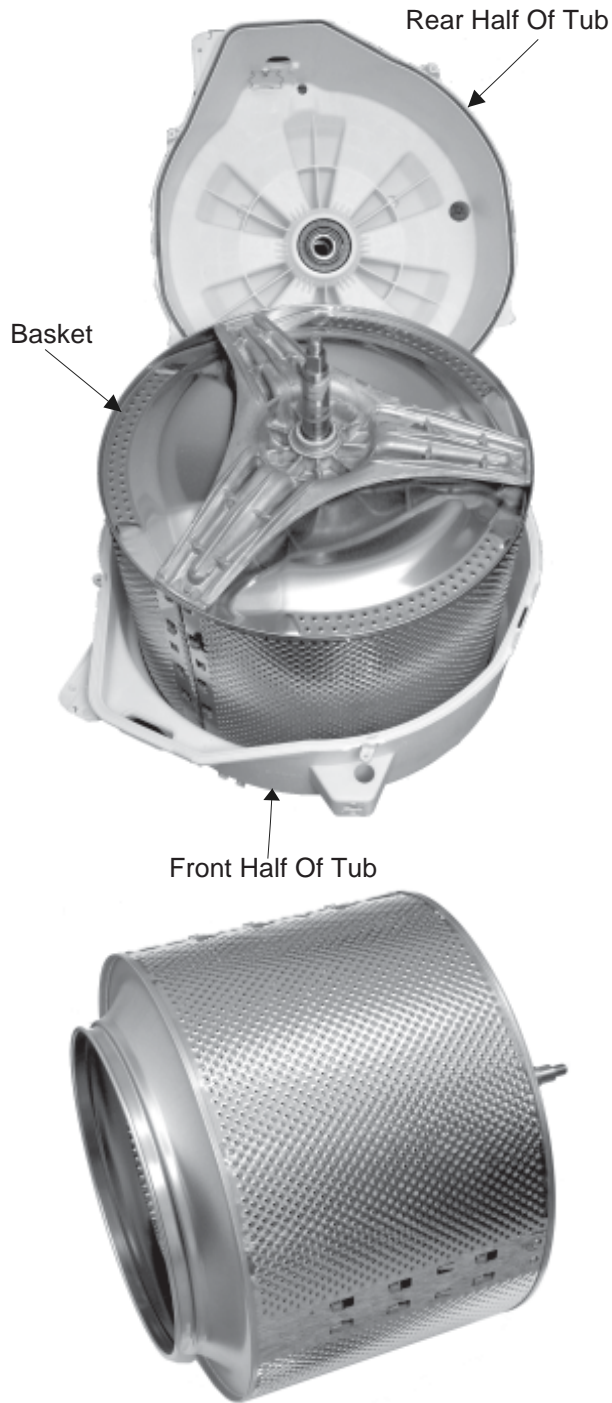

- 25. To replace the heater element wire holder, remove the T-20 torx screw.
- 26. To replace the tub gasket, pry the gasket out of the slot and remove it. **NOTE:** The basket hub is molded into the rear half of the tub. If it is worn and needs to be replaced, you will need to replace the rear half of the tub.



REASSEMBLY NOTES:

1. When reassembling the tub, install the metal clips over the flanges of the two tub sections with a hammer.

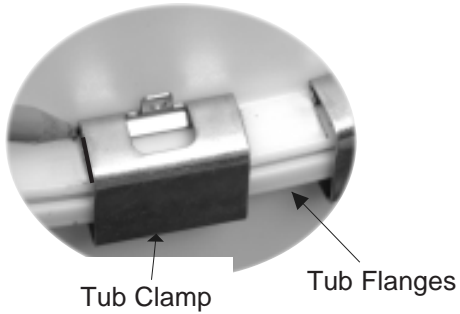

2. When reinstalling the tub assembly, hook the two suspension springs into the front holes of the tub and cabinet.

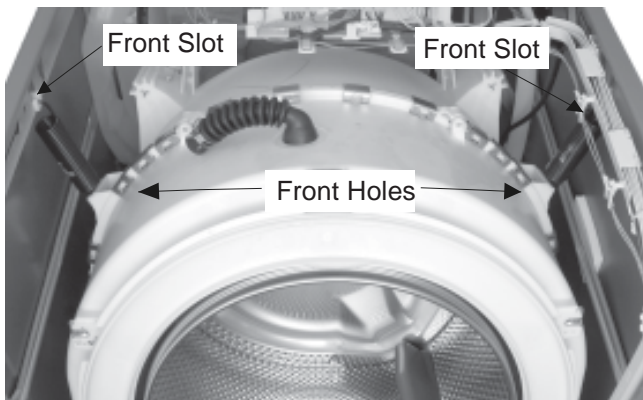

3. When reinstalling the bottom front counterweight, first tape the flat nut in place in the tub slot so it does not fall out.



Bottom Front Counterweight Flat Nut

4. When reinstalling the heating element in the tub, make sure that it is held in place by the wire holder (see the photo in step 27 on the previous page).

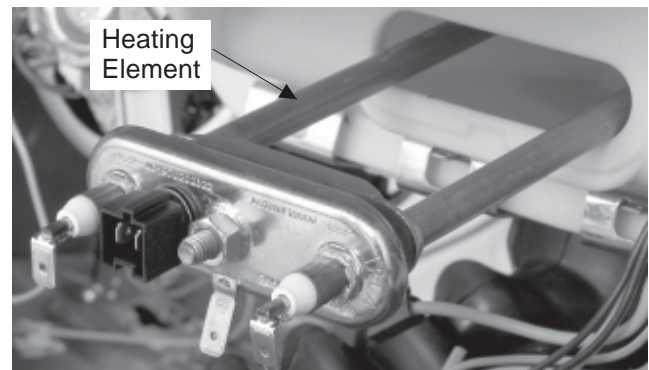

— NOTES —

COMPONENT TESTING

Before testing any of the components, perform the following checks:

- Control failure can be the result of corrosion on connectors. Therefore, disconnecting and reconnecting wires will be necessary throughout test procedures.
- All tests/checks should be made with a VOM or DVM having a sensitivity of 20,000 ohms-per-volt DC, or greater.
- Check all connections before replacing components, looking for broken or loose wires, failed terminals, or wires not pressed into connectors far enough.
- Resistance checks must be made with power cord unplugged from outlet, and with wiring harness or connectors disconnected.
- Unless stated otherwise, make all resistance checks by disconnecting the component connector at the Central Control Unit (CCU).



! WARNING

Electrical Shock Hazard

Disconnect power before servicing.

Replace all parts and panels before operating.

Failure to do so can result in death or electrical shock.

PRESSURE SWITCH

Pin 1 End

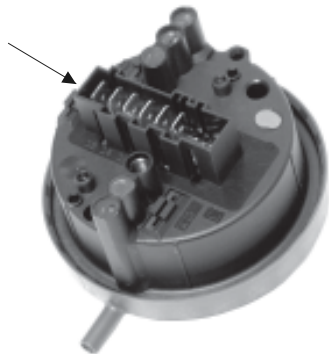

Refer to page 4-13 for the procedure for servicing the pressure switch.

1. Unplug washer or disconnect power.

2. Disconnect the hose and wire connector from the pressure switch.
3. Set the ohmmeter to the R X 1 scale.
4. Touch the ohmmeter test leads to the pressure switch connector pins shown below. The meter should indicate 0 Ω for each measurement.

Water Level Setting Test Points

Empty	Pins 4 and 6
Suds Detect	Pins 1 and 2
L1	Pins 4 and 5
Overflow	Pins 3 and 4



! WARNING

Electrical Shock Hazard

Disconnect power before servicing.
Replace all parts and panels before operating.
Failure to do so can result in death or electrical shock.

DETERGENT DISPENSER MOTOR & SWITCH



Refer to page 4-8 for the procedure for servicing the detergent dispenser motor.

1. Unplug washer or disconnect power.
2. Disconnect the detergent dispenser motor and switch connector from the CCU.
3. Set the ohmmeter to the R x 100 scale.
4. Touch the ohmmeter test leads to the indicated wire connector terminals. The meter should indicate as follows:

Dispenser motor at pins 1 and 3 = 1400 to 1600 Ω .

Dispenser switch at pins 5 and 6 = 0 Ω

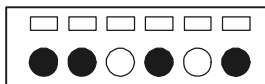

6 5 3 1

(Connector viewed From Wire End)

INLET VALVE SOLENOIDS

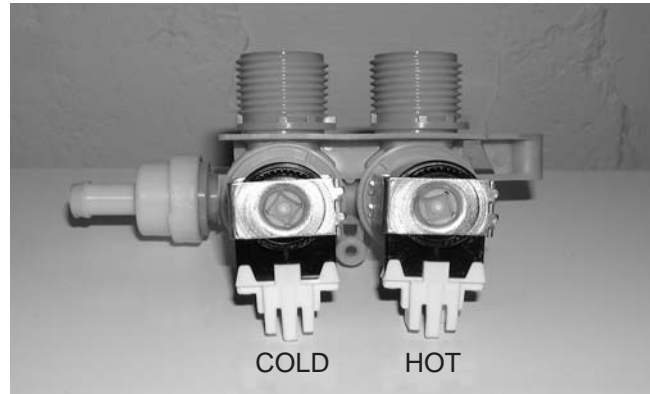

Refer to page 4-10 for the procedure for servicing the inlet valves.

1. Unplug washer or disconnect power.
2. Disconnect the inlet valve solenoid connector from the CCU.
3. Set the ohmmeter to the R x 100 scale.
4. Touch the ohmmeter test leads to the indicated wire connector terminals. The meter should indicate between 750 and 850 Ω .

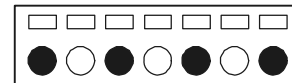

7 5 3 1

(Connector viewed From Wire End)



⚠ WARNING

Electrical Shock Hazard

Disconnect power before servicing.
Replace all parts and panels before operating.
Failure to do so can result in death or electrical shock.

DOOR LOCK/SWITCH ASSEMBLY

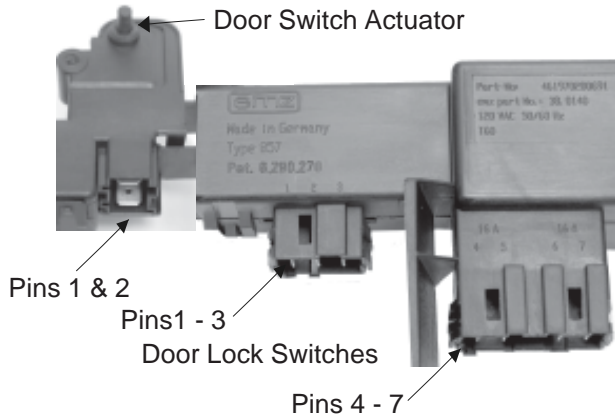

Refer to page 4-4 for the procedure for servicing the door lock/switch assembly.

1. Unplug washer or disconnect power.
2. Set the ohmmeter to the R x 1 scale.
3. **To test the door switch:**
 - a) Disconnect the connector from the CCU.
 - b) Touch the ohmmeter test leads to the two connector terminals. The meter should indicate as follows:
 Door closed = 0 Ω.
 Door open = infinite (open circuit).

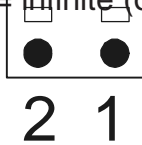

(Connector viewed From Wire End)

- c) Reconnect the door switch connector to the CCU.

4. To test the door lock/unlock solenoids:

- a) Disconnect the connector from the CCU.
- b) Touch the ohmmeter test leads to the indicated connector terminals. The meter should indicate as follows:
 Lock solenoid at pins 1 and 3 = 60 Ω.
 Unlock solenoid at pins 2 and 3 = 60 Ω.

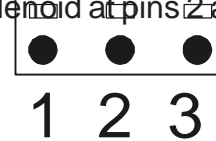

(Connector viewed From Wire End)

- c) Reconnect the door lock/unlock solenoid connector to the CCU.

5. To test the door lock main switches:

- a) Turn the washer on and select a cycle.
- b) Press START and you should hear the door lock solenoids engage.
- c) Unplug the washer from the wall outlet.
- d) Disconnect the door lock main switch connector from the CCU.
- e) Touch the ohmmeter test leads to the indicated connector terminals. The meter should indicate as follows:
 Main switch 1 at pins 4 and 5 = 0 Ω.
 Main switch 2 at pins 6 and 7 = 0 Ω.

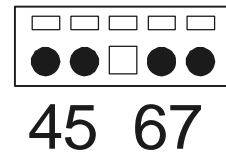

(Connector viewed From Wire End)



⚠️ WARNING

Electrical Shock Hazard

Disconnect power before servicing.
Replace all parts and panels before operating.
Failure to do so can result in death or electrical shock.

DRAIN PUMP MOTOR

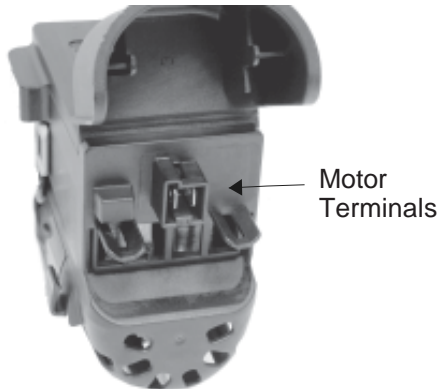

Refer to page 4-18 for the procedure for servicing the drain pump assembly.

1. Unplug washer or disconnect power.
2. Disconnect the drain pump motor connector from the CCU.
3. Set the ohmmeter to the R x 1 scale.
4. Touch the ohmmeter test leads to the two drain pump motor connector pins. The meter should indicate 15 Ω .

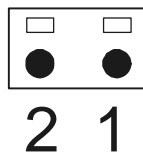

(Connector viewed From Wire End)

INTERFERENCE FILTER



Refer to page 4-12 for the procedure for servicing the interference filter.

1. Unplug washer or disconnect power.
2. Disconnect the wire connectors from the interference filter terminals.
3. Set the ohmmeter to the R x 10K scale.
4. Touch the ohmmeter test leads to the interference filter connector pins. The meter should indicate approximately 450K Ω .



⚠️ WARNING

Electrical Shock Hazard

Disconnect power before servicing.
Replace all parts and panels before operating.
Failure to do so can result in death or electrical shock.

HEATING ELEMENT & TEMPERATURE SENSOR

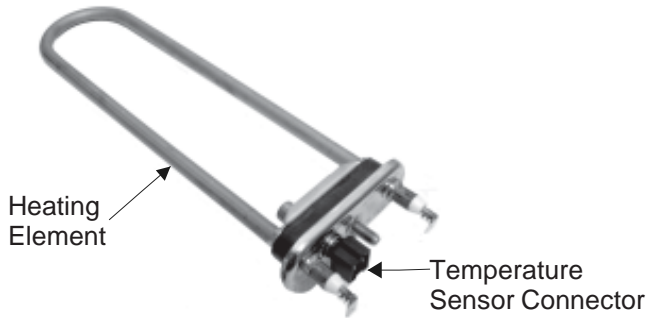

Temperature	Results
32°F (0°C)	35.9K ohms
86°F (3°C)	9.7K ohms
104°F (40°C)	6.6K ohms
122°F (50°C)	4.6K ohms
140°F (60°C)	3.2K ohms
158°F (70°C)	2.3K ohms
203°F (95°C)	1K ohms

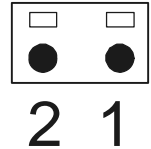

Refer to page 4-16 for the procedure for servicing the heating element & temperature sensor.

1. Unplug washer or disconnect power.
2. Disconnect the wire connectors from the heating element and temperature sensor terminals.
3. Set the ohmmeter to the R x 1 scale.
4. Touch the ohmmeter test leads to the two heating element terminals. The meter should indicate between 10 and 20 Ω .
5. Disconnect the heating element temperature sensor connector from the CCU.
6. Touch the ohmmeter test leads to the two temperature sensor connector terminals. The meter should indicate as shown in the following chart.



! WARNING

Electrical Shock Hazard

Disconnect power before servicing.

Replace all parts and panels before operating.

Failure to do so can result in death or electrical shock.

DRIVE MOTOR

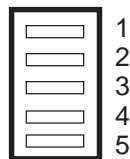
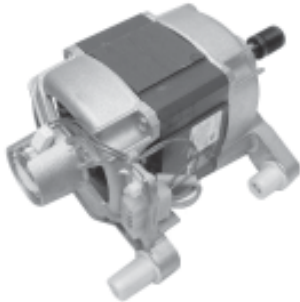

(Connector viewed From Wire End)

Refer to page 4-22 for the procedure for servicing the drive motor.

1. Unplug washer or disconnect power.
2. Disconnect the wire connector from the drive motor terminals.
3. Set the ohmmeter to the R x 1 scale.
4. Touch the ohmmeter test leads to the following drive motor terminals. The meter should indicate between 3 and 8 Ω .

Terminals 1 & 2

Terminals 1 & 3

Terminals 2 & 3

NOTE: Terminals 4 and 5 are for the tachometer.

INTERLOCK SWITCH



Refer to page 4-20 for the procedure for servicing an interlock switch.

1. Unplug washer or disconnect power.
2. Disconnect the wires from the interlock switch terminals.
3. Set the ohmmeter to the R X 1 scale.
4. Touch the ohmmeter test leads to the two interlock switch terminals. The meter should indicate an open circuit with the actuator in, and a closed circuit (0 Ω) with the actuator out.

DIAGNOSTICS & TROUBLESHOOTING

DIAGNOSTICS

WARNING



Electrical Shock Hazard
Disconnect power before servicing.
Replace all parts and panels before operating.
Failure to do so can result in death or electrical shock.

IMPORTANT

Electrostatic Discharge (ESD) Sensitive Electronics

ESD problems are present everywhere. ESD may damage or weaken the electronic control board. The new control assembly may appear to work well after repair is finished, but failure may occur at a later date due to ESD stress.

- Use an anti-static wrist strap. Connect wrist strap to green ground connection point or unpainted metal in the appliance.

-OR-

Touch your finger repeatedly to a green ground connection point or unpainted metal in the appliance.

- Before removing the part from its package, touch the anti-static bag to a green ground connection point or unpainted metal in the appliance.
- Avoid touching electronic parts or terminal contacts; handle electronic control board by edges only.
- When repackaging failed electronic control board in anti-static bag, observe above instructions.

DIAGNOSTIC GUIDE

Before servicing, check the following:

- Make sure there is power at the wall outlet.
- Has a household fuse blown or circuit breaker tripped? Time delay fuse?
- Are both hot and cold water faucets open and the water supply hoses unobstructed?
- All tests/checks should be made with a VOM or DVM having a sensitivity of 20,000 ohms per volt DC or greater.
- Check all connections before replacing components. Look for broken or loose wires, failed terminals, or wires not pressed into connectors far enough.
- The most common cause for control failure is corrosion on connectors. Therefore, disconnecting and reconnecting wires will be necessary throughout test procedures.
- Connectors: Look at top of connector. Check for broken or loose wires. Check for wires not pressed into connector far enough to engage metal barbs.
- Resistance checks must be made with power cord unplugged from outlet.

FAILURE/ERROR DISPLAY CODES

DISPLAY	EXPLANATION AND RECOMMENDED PROCEDURE
F/H	NO WATER DETECTED ENTERING MACHINE OR PRESSURE SWITCH TRIP NOT DETECTED
	<p>If after 30 seconds the control does not detect water entering machine, the valves will be turned off and the error code will be displayed.</p> <p style="text-align: center;">OR</p> <p>If the control has turned the water valves on, and after 8 minutes, the flow sensor has detected 10.5 gallons of water passing through it, but has not detected the pressure switch trip, the valves will be turned off, and the error code will flash.</p> <p>Press PAUSE/CANCEL twice to clear the display.</p>
	<p><i>Possible Causes / Procedure</i></p> <ul style="list-style-type: none"> • If there is no water in the unit: <ul style="list-style-type: none"> - Make sure that both valves at the water source(s) are turned on all the way. - Check for plugged or kinked inlet hoses or plugged screens in the inlet valves. - Verify inlet valve operation. • If there is water in the unit: <ul style="list-style-type: none"> - Verify drain pump operation. - Verify that the pressure switch hose is in good condition and properly connected to tub and pressure switch. <ol style="list-style-type: none"> 1. Verify there is not a siphon problem. 2. Unplug washer or disconnect power. 3. Verify wire harness connections to inlet valves, pressure switch, drain pump, flow meter, and Central Control Unit (CCU). 4. Check all hoses for possible leaks. 5. Plug in washer or reconnect power. 6. Verify pressure switch operation. 7. Verify flow meter operation by blowing air through the part and measuring the resistance. 8. Verify CCU operation by running a Diagnostic test or any cycle.

DISPLAY	EXPLANATION AND RECOMMENDED PROCEDURE
F/02	LONG DRAIN
	<p>If the drain time exceeds eight minutes, the water valves are turned off and “F/02 ” is flashed. Press PAUSE/CANCEL two times to clear the display.</p> <p>NOTE: After four minutes the “Sud” error will be displayed, then four minutes later the “F/02 ” error code will be displayed..</p>
	<p><u>Possible Causes / Procedure</u></p> <ol style="list-style-type: none"> 1. Check the drain hose and make sure it is not plugged or kinked. 2. Unplug washer or disconnect power. 3. Check the electrical connections at the pump and make sure the pump is running. 4. Check the drain pump filter for foreign objects. 5. Plug in washer or reconnect power. 6. If the above does not correct the problem, go to step 7. 7. Unplug washer or disconnect power. 8. Replace the pump.
F/05	WATER TEMPERATURE SENSOR ERROR
	<p>If during the water heating step in the wash cycle, the water temperature sensor (NTC) value is out of range, the “F/05” error code will be displayed.</p>
	<p><u>Possible Causes / Procedure</u></p> <ol style="list-style-type: none"> 1. Unplug washer or disconnect power. 2. Check the water temperature sensor. Refer to the “Water Temperature Sensor ” section. Check connections to the water temperature sensor. 3. Check resistance of heating element, if present on this model. (abnormal = infinity)
F/06	DRIVE MOTOR TACHOMETER ERROR
	<p>The control is unable to properly detect motor speed and the machine will shut down. If a failure occurs during high-speed spin, the door will be unlocked after three minutes.</p>
	<p><u>Possible Causes / Procedure</u></p> <ol style="list-style-type: none"> 1. Verify the shipping system including shipping bolts, spacers and cables are removed. 2. Unplug washer or disconnect power. 3. Check wire harness connections between the drive motor and the Motor Control Unit (MCU), and between the MCU and the Central Control Unit (CCU). 4. Plug in washer or reconnect power. 5. Check the MCU by looking for operations of the drive motor. 6. Check the drive motor for powered rotations.

DISPLAY	EXPLANATION AND RECOMMENDED PROCEDURE
F/07	MOTOR CONTROL UNIT ERROR
	The main control has detected a short in the Motor Control Unit. If a failure occurs during high-speed spin, the door will be unlocked after three minutes.
	<p><u>Possible Causes / Procedure</u></p> <ol style="list-style-type: none"> 1. Unplug washer or disconnect power. 2. Check wire harness connections between the drive motor and the Motor Control Unit (MCU), and between the MCU and the Central Control Unit (CCU). 3. Plug in washer or reconnect power. 4. Check the MCU by looking for operations of the drive motor. 5. Check the drive motor for powered rotations.
F/09	OVERFLOW CONDITION
	If the overflow contact on the pressure switch is closed for more than 60 seconds, an Overflow Condition will occur. In an overflow condition, the door remains locked and the drain pump runs constantly, even if PAUSE/CANCEL is pressed twice and the display is cleared. Turn off hot and cold water faucets and unplug the unit before servicing.
	<p><u>Possible Causes / Procedure</u></p> <ol style="list-style-type: none"> 1. Check the drain hose and make sure it is not plugged or kinked. 2. Unplug washer or disconnect power. 3. Check wire harness connections to the drain pump, pressure switch, and Central Control Unit (CCU). 4. Check/clean drain pump filter of foreign objects. 5. Check for drain pump failure. 6. Check the inlet valve for proper shut off. 7. Check the pressure switch for proper operation.
F/10	MOTOR CONTROL UNIT (MCU) HEAT SINK THERMAL TRIP
	If the thermal protector on the MCU heat sink gets too hot, it will open the thermal protector on the heat sink which will stop motor functions and an "F/10" will be displayed.
	<p><u>Possible Causes / Procedure</u></p> <ol style="list-style-type: none"> 1. Check for proper installation, verify the unit is not located near a source of heat and has proper ventilation. 2. Unplug washer or disconnect power. 3. Check wire harness connections to the MCU, the motor, and Central Control Unit (CCU). 4. Check the drive system for any worn or failed components. 5. Plug in washer or reconnect power. 6. Check the MCU by looking for operations of the drive motor. 7. Check the drive motor for powered rotations.

DISPLAY	EXPLANATION AND RECOMMENDED PROCEDURE
F/11	SERIAL COMMUNICATION ERROR
	Communication between the Central Control Unit (CCU) and the Motor Control Unit (MCU) cannot be sent correctly.
	<p><i>Possible Causes / Procedure</i></p> <ol style="list-style-type: none"> 1. Unplug washer or disconnect power. 2. Check wire harness connections to the MCU, the motor, and Central Control Unit (CCU). 3. Check the drive system for any worn or failed components. 4. Plug in washer or reconnect power. 5. Verify CCU operation by running a Diagnostic test or any cycle. 6. Check the MCU by looking for operations of the drive motor. 7. Check the drive motor for powered rotations. 8. Check that the serial harness at the MCU is not mounted upside down. The wires should be to the left when facing the MCU connectors.
F/13	DISPENSER CIRCUIT ERROR
	If the dispenser motor is not able to be driven to its proper position.
	<p><i>Possible Causes / Procedure</i></p> <ol style="list-style-type: none"> 1. Unplug washer or disconnect power. 2. Check mechanical linkage from dispenser motor to the top of the dispenser. 3. Check wire harness connections to the dispenser motor and Central Control Unit (CCU). 4. Check dispenser motor for powered rotations.
F/14	EEPROM ERROR
	The Central Control Unit (CCU) receives its data from an EEPROM onboard the CCU. If there is an error reading this data it will cause this error.
	<p><i>Possible Causes / Procedure</i></p> <ul style="list-style-type: none"> • A power glitch may cause this error. <ol style="list-style-type: none"> 1. Unplug washer or disconnect power for two minutes. 2. Verify CCU operation by running a Diagnostic test or any cycle.
F/15	MOTOR CONTROL UNIT (MCU) ERROR
	If the MCU detects multiple resets or errors during a wash cycle it will go into this error mode.
	<p><i>Possible Causes / Procedure</i></p> <ol style="list-style-type: none"> 1. Unplug washer or disconnect power. 2. Check wire harness connections to the MCU, the motor, and Central Control Unit (CCU). 3. Check drive belt. 4. Plug in washer or reconnect power. 5. Check the MCU by looking for operations of the drive motor. 6. Check the drive motor for powered rotations.

DISPLAY	EXPLANATION AND RECOMMENDED PROCEDURE
F/21 F/22	CCU / TOUCHPAD / LED ASSEMBLY ERROR
	This error occurs if the touchpad/LED assembly is not able to transmit/receive data to/from the central control unit (CCU).
	<p><u>Possible Causes / Procedure</u></p> <ol style="list-style-type: none"> 1. Check the touchpad/LED assembly by selecting different cycles and changing the modifiers and options available to confirm the touchpad/LED is responding. 2. Unplug washer or disconnect power. 3. Check wire harness connections to the touchpad/LED assembly and Central Control Unit (CCU).
F/dU	DOOR UNLOCK ERROR
	A Door Unlock Error occurs if the door cannot be unlocked. It will try to unlock the door six times before displaying the error code.
	<p><u>Possible Causes / Procedure</u></p> <ul style="list-style-type: none"> • Door lock mechanism is broken. • Door switch/lock unit failure. <ol style="list-style-type: none"> 1. Check door switch/lock unit for foreign objects. 2. Unplug washer or disconnect power. 3. Check wire harness connections to the door switch/lock unit and Central Control Unit (CCU). <p>NOTE: The door switch/lock unit can be manually unlocked. See “Manually Unlocking The Door Lock System”.</p>
F/dL	DOOR LOCK ERROR
	A Door Lock Error occurs if the door cannot be locked. It will try to lock it six times before displaying the error code.
	<p><u>Possible Causes / Procedure</u></p> <ul style="list-style-type: none"> • Door lock mechanism is broken or removed from door. • Door switch/lock unit failure. <ol style="list-style-type: none"> 1. Unplug washer or disconnect power. 2. Check door switch/lock unit. 3. Check the wire harness connections to the door switch/lock unit and Central Control Unit (CCU).

DISPLAY	EXPLANATION AND RECOMMENDED PROCEDURE
Sud	SUDS LOCK (OVERDOSE OF DETERGENT DETECTED DURING THE WASH CYCLE)
	<p>The Motor Control Unit senses a suds lock condition by analyzing the current draw on the drive motor. If “Sud ”is displayed a potential Suds Lock is detected. This may signify a bad pump, an extra heavy load, excessive detergent, or excessive suds.</p>
	<p><u>Possible Causes / Procedure</u></p> <ul style="list-style-type: none"> • If too much detergent was used: <ul style="list-style-type: none"> - Run the unit through a Rinse/Spin cycle. - Run a Normal cycle without adding any detergent. <p>This should clear the unit of the excess detergent.</p> <ol style="list-style-type: none"> 1. Check the drain hose and make sure it is not plugged or kinked. 2. Unplug washer or disconnect power. 3. Check wire harness connections to the drain pump, pressure switch, and Central Control Unit (CCU). 4. Check/clean drain pump filter of foreign objects. 5. Plug in washer or reconnect power. 6. Check drain pump. 7. Check the pressure switch. 8. Verify CCU operation by running a Diagnostic test or any cycle.

DIAGNOSTIC TEST

The washer must be empty and the control must be in the OFF state before pressing the touchpad sequence to start the test.

Starting the Test Mode

- Close the door.
- Push CONTROL/ON (if present on this model).
- Select the DRAIN/SPIN cycle.
- Select NO SPIN by pressing the SPIN SPEED touchpad.

- Push PREWASH OPTION four times within five seconds. (If PREWASH OPTION is not present on this model, press RINSE HOLD four times within five seconds.) **C:00** will light up on the display.

If the Starting procedure fails, push the PAUSE/CANCEL touchpad, then repeat the starting procedure.

Test Program Control

In order to advance to the next step of the test procedure, push PREWASH OPTION touchpad two times. If PREWASH OPTION is not present on this model, press RINSE HOLD two times.

Indication	Control Action	Actuators To Be Checked
C:00	Door locks.	• Door lock system
C:01	Fill by cold water inlet valve.	• Flowmeter • Cold water inlet valve
C:02	Distribution system is set to Prewash position.	• Dispenser motor • Dispenser contact
C:03	Fill by hot water inlet valve.	• Hot water inlet valve
C:04	Drum rotates clockwise at wash speed.	• Motor • Motor Control (MCU)
C:05	Heater (if present on this model) is switched ON. Drum rotates clockwise at wash speed. If there is not enough water in the tub, the water inlet valve will be switched ON to achieve the minimum water volume.	• Heater (if present on this model) • NTC
C:06	Drain pump is ON.	• Drain pump
C:07	Drum rotates counterclockwise from 35 to 90 rpm within 15 seconds.	• Motor • Motor Control (MCU)
C:08	Drum rotates counterclockwise at maximum speed. - If max. speed =EXTRA HIGH, drum speed = >1000 rpm. - If max. speed =HIGH, drum speed = >800 rpm.	• Motor • Motor Control (MCU)

Be sure to perform the Diagnostic Tests on the previous page before replacing the system components.

Motor Continuity Test

1. Unplug washer or disconnect power.
2. Disconnect the wire harness from the motor and measure the resistance of the motor. Use the following table:

Pins	Results
1 to 2	Normal = 6 Ω (approximate) Abnormal = Infinity
2 to 3	
1 to 3	

Water Temperature Sensor

1. Unplug washer or disconnect power.
2. Disconnect the wire harness from the water temperature sensor and measure the resistance of the sensor. Use the following table. An abnormal condition is an open circuit.

Temperature	Results
32°F / 0°C	35.9 k Ω
86°F / 30°C	9.7 k Ω
104°F / 40°C	6.6 k Ω
122°F / 50°C	4.6 k Ω
140°F / 60°C	3.2 k Ω
158°F / 71°C	2.3 k Ω
203°F / 96°C	1 k Ω

Manually Unlocking The Door Lock System

1. Unplug washer or disconnect power.
2. Remove the lower kick panel.
3. Reach up along the inside of the front and locate the bottom of the door switch/lock unit.
4. Located on the bottom of the door switch/lock unit is a teardrop shaped tab.
5. Gently pull the tab down about a 1/4 inch or until a click is heard.
6. The door may be opened.

CONTROL BOARD REMOVAL OR REPLACEMENT

IMPORTANT: Electrostatic (static electricity) discharge may cause damage to electronic control assemblies.

NOTE: Be sure to perform the Diagnostic Tests before replacing the control board.

To remove Central Control Unit (CCU):

1. Unplug washer or disconnect power.
2. Remove all connectors from the CCU.
3. Place two flat blade screwdrivers under the left and right tab, on the top of the CCU and slide the CCU forward.

To reassemble CCU:

1. Align the tab on top of the CCU with the notch in the cabinet. Also, align the posts on the back of the CCU with the hole in the back of the cabinet.
2. Slide the CCU back into place.
3. Reconnect wire harness.

To remove the touchpad/LED assembly:

1. Unplug washer or disconnect power.
2. Disconnect touchpad/LED assembly wire harness from the CCU.
3. Remove dispenser drawer.
4. Remove left front screw that was covered by the dispenser drawer.
5. Open door, under the center of the touchpad/LED assembly there is a notch, insert a flat blade screwdriver in notch to release the bottom of the touchpad/LED assembly.
6. On the right hand side behind the touchpad/LED assembly, press tab to release right side of the touchpad/LED assembly.
7. Gently pry up and release the top of the touchpad/LED assembly. This should completely release the entire touchpad/LED assembly.

To remove Motor Control Unit (MCU):

1. Unplug washer or disconnect power.
2. Remove wire harness cover and disconnect the wire harness from the MCU.
3. With a flat blade screwdriver, lift the front tab up and slide the MCU forward.

To remove line/ interference filter:

1. Unplug washer or disconnect power.
2. Disconnect the three connectors from the line filter and power cord.
3. Remove the two screws which secure the line filter to the top brace.

TROUBLESHOOTING CHART

PROBLEM	POSSIBLE CAUSE/TEST
	NOTE: Possible Cause/Tests must be performed in the sequence shown for each problem
WILL NOT POWER UP Touchpads do not respond when pressed	<ol style="list-style-type: none"> 1. Check that the unit is plugged into a working outlet and for blown fuses. 2. Check for power going to Central Control Unit (CCU) by listening for a click in the CCU when unit is plugged in. If no click, replace CCU. 3. Unplug washer or disconnect power. 4. Check continuity of line cord and line filter. 5. Check harness connections to CCU. 6. Plug in washer or reconnect power. 7. Check the touchpad/LED assembly by selecting different cycles and changing the modifiers and options available to confirm the touchpad/LED is responding.
WILL NOT START CYCLE	<ol style="list-style-type: none"> 1. Open and close the door. The door has to be opened between consecutive wash cycles. 2. Check the door switch/lock unit using the diagnostics (see Diagnostic test). 3. If door is locked, drain the unit. 4. Unplug washer or disconnect power. 5. Check the wire harness connections. 6. Plug in washer or reconnect power. 7. Check the touchpad/LED assembly by selecting different cycles and changing the modifiers and options available to confirm the touchpad/LED is responding.
WILL NOT SHUT OFF	<ol style="list-style-type: none"> 1. Check for a Fault/Error Code on the display. 2. Press PAUSE/CANCEL button on the touchpad twice. 3. Check the touchpad/LED assembly by selecting different cycles and changing the modifiers and options available to confirm the touchpad/LED is responding. 4. Unplug washer or disconnect power. 5. Check that the drain hose and drain pump filter are clear of foreign objects and not plugged. 6. Plug in washer or reconnect power. 7. Check drain pump. 8. Verify CCU operation by running a Diagnostic test or any cycle.
CONTROL WILL NOT ACCEPT SELECTIONS	<ol style="list-style-type: none"> 1. Press PAUSE/CANCEL button on the touchpad twice. 2. Drain the unit, then check that the drain hose and drain pump filter are clear of foreign objects. 3. Check the touchpad/LED assembly by selecting different cycles and changing the modifiers and options available to confirm the touchpad/LED is responding. 4. Unplug washer or disconnect power. 5. Check harness connections. 6. Plug in washer or reconnect power. 7. Verify CCU operation by running a Diagnostic test or any cycle.

PROBLEM	POSSIBLE CAUSE/TEST
	NOTE: Possible Cause/Tests must be performed in the sequence shown for each problem
WILL NOT DISPENSE	<ol style="list-style-type: none"> 1. Verify the unit is level. 2. Verify dispenser drawer is not clogged with detergent. 3. Check water connections to the unit and within the unit. Check for plugged screen in water source. 4. Check dispenser motor. 5. Unplug washer or disconnect power. 6. Check harness connections. 7. Plug in washer or reconnect power. 8. Verify CCU operation by running a Diagnostic test or any cycle.
WILL NOT FILL	<ol style="list-style-type: none"> 1. Check installation. Verify hot and cold water faucets are open. 2. Check inlet valves. 3. Check water connections to the unit and within the unit. Make sure water supply hoses are unobstructed. Check for plugged screen. 4. Plug in washer or reconnect power. 5. Check operating pressure switch. 6. Check drain pump motor. 7. Verify CCU operation by running a Diagnostic test or any cycle. 8. Check under problem "Will Not Dispense."
OVER FILLS	<ol style="list-style-type: none"> 1. Verify the unit is level. 2. Check pump drain system. This could indicate a failure to drain. 3. Check operating pressure switch. 4. Check pressure switch hose. 5. Verify flow meter operation by blowing air though the part and measuring the resistance. 6. Verify CCU operation by running a Diagnostic test or any cycle.
DRUM WILL NOT ROTATE	<ol style="list-style-type: none"> 1. Check drive belt. 2. Check drive motor. 3. Unplug washer or disconnect power. 4. Check wire harness connections. 5. Plug in washer or reconnect power. 6. Check the MCU by looking for operations of the drive motor.
MOTOR OVERHEATS	<ol style="list-style-type: none"> 1. Check drive motor. 2. Unplug washer or disconnect power. 3. Check wire harness connections. 4. Check drive belt. 5. Plug in washer or reconnect power. 6. Check the MCU by looking for operations of the drive motor.

PROBLEM	POSSIBLE CAUSE/TEST
	NOTE: Possible Cause/Tests must be performed in the sequence shown for each problem
WILL NOT DRAIN	<ol style="list-style-type: none"> 1. Unplug washer or disconnect power. 2. Check wire harness connections. 3. Check drain pump. 4. Check drain pump motor. 5. Check that the drain hose and drain pump filter are clear of foreign objects. 6. Plug in washer or reconnect power. 7. Verify CCU operation by running a Diagnostic test or any cycle.
MACHINE VIBRATES	<ol style="list-style-type: none"> 1. Remove shipping system. 2. Check installation. 3. Check leveling feet.
INCORRECT WATER TEMPERATURE	<ol style="list-style-type: none"> 1. Check that the inlet hoses are connected properly. 2. Unplug washer or disconnect power. 3. Check the water heater and wire harness connections to it. 4. Check water temperature sensor for an abnormal condition (see "Water Temperature Sensor"). 5. Plug in washer or reconnect power. 6. Verify CCU operation by running a Diagnostic test or any cycle.
DISPLAY IS FLASHING	See "Failure/Error Display Codes."

— NOTES —

WIRING DIAGRAM

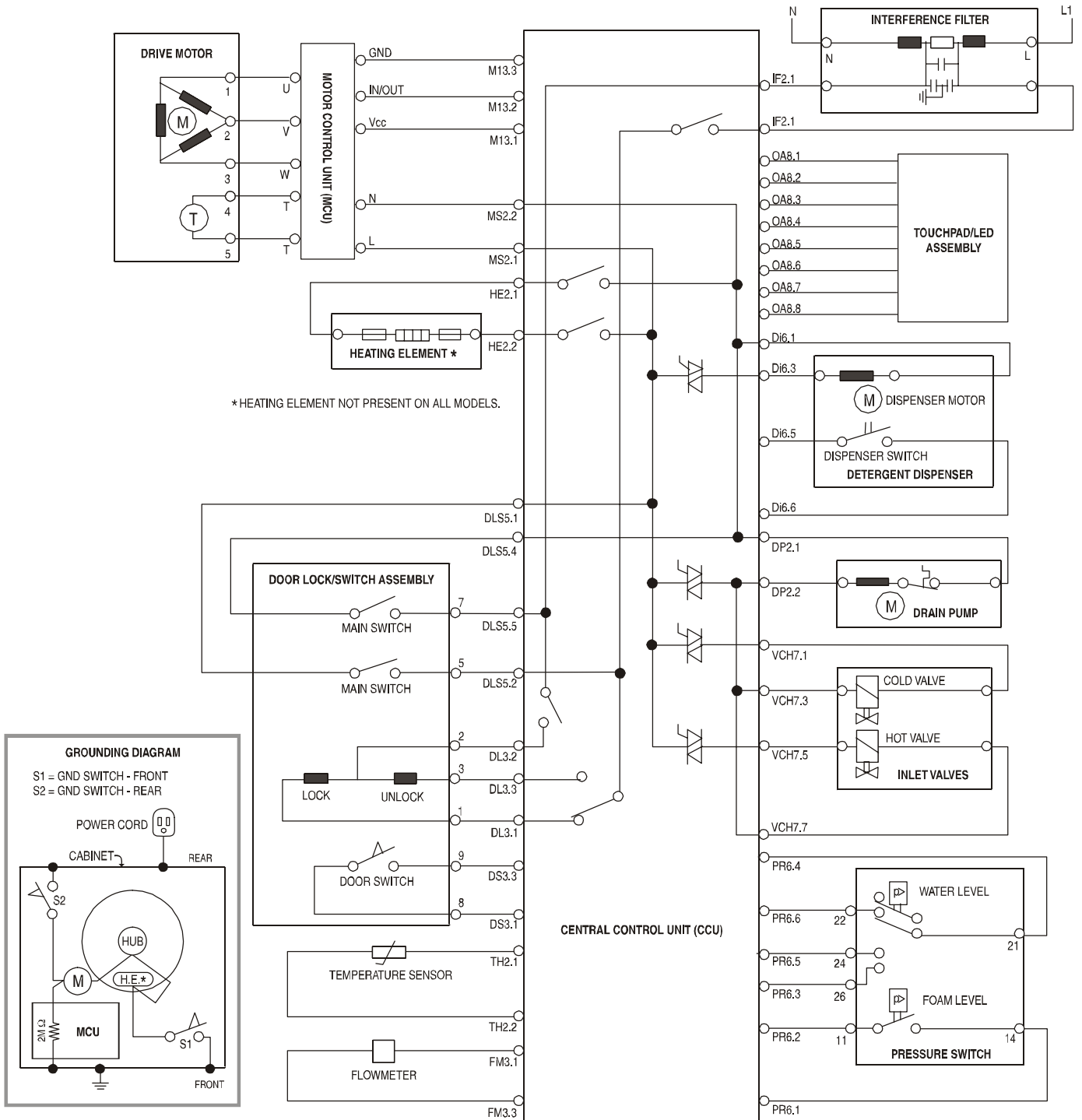

— NOTES —

PRODUCT SPECIFICATIONS AND WARRANTY INFORMATION SOURCES

IN THE UNITED STATES:

FOR PRODUCT SPECIFICATIONS AND WARRANTY INFORMATION CALL:

FOR WHIRLPOOL PRODUCTS: 1-800-253-1301
FOR KITCHENAID PRODUCTS: 1-800-422-1230
FOR ROPER PRODUCTS: 1-800-447-6737
FOR MAYTAG PRODUCTS: 1-800-688-9900

FOR TECHNICAL ASSISTANCE WHILE AT THE CUSTOMER'S HOME CALL:

THE TECHNICAL ASSISTANCE LINE: 1-800-253-2870

**HAVE YOUR STORE NUMBER READY TO IDENTIFY YOU AS AN
AUTHORIZED IN HOME SERVICE PROFESSIONAL**

FOR LITERATURE ORDERS:

PHONE: 1-800-851-4605

FOR TECHNICAL INFORMATION AND SERVICE POINTERS:

www.servicematters.com

IN CANADA:

FOR PRODUCT SPECIFICATIONS AND WARRANTY INFORMATION CALL:

1-800-688-2002

FOR TECHNICAL ASSISTANCE WHILE AT THE CUSTOMER'S HOME CALL:

THE TECHNICAL ASSISTANCE LINE: 1-800-488-4791

**HAVE YOUR STORE NUMBER READY TO IDENTIFY YOU AS AN
AUTHORIZED IN HOME SERVICE PROFESSIONAL**

MAYTAG®

