



**MAYTAG**

# Maytag Performa

**Washer  
Service Manual**

16023083

# **SAFETY PRECAUTIONS**

**THIS MANUAL, AS WELL AS THE INFORMATION CONTAINED IN IT, IS TO BE USED ONLY BY A MAYTAG AUTHORIZED SERVICE TECHNICIAN FAMILIAR WITH AND KNOWLEDGEABLE OF PROPER SAFETY AND SERVICING PROCEDURES AND POSSESSING HIGH QUALITY TESTING EQUIPMENT ASSOCIATED WITH MICROWAVE, GAS, AND ELECTRICAL APPLIANCE REPAIR.**

**ALL INDIVIDUALS WHO ATTEMPT REPAIRS BY IMPROPER MEANS OR ADJUSTMENTS, SUBJECT THEMSELVES AND OTHERS TO THE RISK OF SERIOUS OR FATAL INJURY.**

***USE ONLY GENUINE MAYTAG APPROVED FACTORY REPLACEMENT COMPONENTS.***

---

# INTRODUCTION

The information presented in this manual is printed in a loose format and is divided into sections relating to a general group of components and/or service procedures. Each section is further subdivided to describe a particular component or service procedure.

Anything of a unique nature concerning these models has been detailed and labeled as such in the manual.

The subdividing of the subject matter, plus the loose leaf form will facilitate the updating of the manual as new or revised components are added or new models are introduced.

Each page of the manual will be identified in the lower right-hand corner, and as new or revised pages are published, the manual can easily be updated by following the file instructions on the cover letter of the supplement.

The service manual is a valuable tool and care should be taken to keep it up to date by prompt and proper filing of subsequent pages as they are used.

## **MODELS COVERED IN THIS MANUAL**

<b>DLW231*</b>	<b>PAV1000AW*</b>
<b>PAV2300*</b>	<b>PAV2000AW*</b>
<b>PAV3300*</b>	<b>PAVT344*</b>
<b>PAV5000*</b>	<b>HAV2460*</b>
<b>PAV5157*</b>	<b>PAVT244*</b>
<b>PAV5158*</b>	<b>PAVT234*</b>
	<b>HAV2360*</b>
	<b>MAV2200*</b>
	<b>HAV2557*</b>
	<b>HAV2558*</b>
	<b>HAV3460*</b>
	<b>PAVT444*</b>
	<b>HAV4657*</b>



---

# CONTENTS

<b>SECTION 1. INSTALLATION</b> .....	<b>1-1</b>
PRE-INSTALLATION REQUIREMENT .....	1-1
Water Supply Requirements .....	1-1
Drain Requirements .....	1-1
Electrical Requirements .....	1-2
INSTALLATION PROCEDURE .....	1-2
<b>SECTION 2. OUTLINE OF MECHANICAL OPERATION</b> .....	<b>2-1</b>
CLUTCH ASSEMBLY .....	2-1
AGITATION .....	2-2
SPIN .....	2-2
<b>SECTION 3. CABINET ASSEMBLY COMPONENTS</b> .....	<b>3-1</b>
CABINET BODY ASSEMBLY .....	3-1
Front Panel .....	3-1
Rear Access Panel .....	3-2
TOP ASSEMBLY .....	3-3
DOOR ASSEMBLY .....	3-4
CONTROL PANEL ASSEMBLY (PAV1000AWW, PAV2000AWW) .....	3-4
Disassembly .....	3-4
CONTROL PANEL ASSEMBLY (PAV2200, 3200, 4200) .....	3-6
Disassembly .....	3-6
BASE ASSEMBLY .....	3-8
STABILIZER ASSEMBLY .....	3-9
<b>SECTION 4. WATER RELATED COMPONENTS</b> .....	<b>4-1</b>
WATER MIXING VALVE .....	4-2
WATER INLET FLUME .....	4-3
AIR BELL .....	4-3
HOSES .....	4-3
TUB TOP .....	4-4
AGITATOR (PAV1000AWW, PAV2000AWW) .....	4-4
AGITATOR (PAV2200, 3200, 4200) .....	4-5
SPIN BASKET .....	4-5
OUTER TUB ASSEMBLY .....	4-6
PUMP ASSEMBLY .....	4-7
<b>SECTION 5. SUSPENSION SYSTEM (PAV1000AWW, PAV2000AWW) ...</b>	<b>5-1</b>
SUSPENSION SYSTEM (PAV2200, 3200, 4200) .....	5-2
SUSPENSION HOUSING .....	5-3
TUB BRACES .....	5-3
SUSPENSION SPRINGS .....	5-3

<b>SECTION 6. TRANSMISSION AND RELATED COMPONENTS .....</b>	<b>6-1</b>
CENTER POST ASSEMBLY .....	6-2
BEARING AND SEAL HOUSING .....	6-2
TUB SEAL .....	6-3
SPIN BEARING .....	6-4
DRIVE PULLEY AND CAMS .....	6-5
BRAKE ASSEMBLY .....	6-8
TRANSMISSION HOUSING ASSEMBLY .....	6-10
Oil Seal Replacement .....	6-11
LOWER BEARING ASSEMBLY .....	6-11
DIAGNOSING TRANSMISSION PROBLEMS .....	6-13
<b>SECTION 7. ELECTRICAL COMPONENTS AND TESTING .....</b>	<b>7-1</b>
TIMER .....	7-1
TIMER SEQUENCE CHART .....	7-2
MOTOR .....	7-3
MOTOR SWITCH .....	7-3
MOTOR MOUNTING .....	7-6
MOTOR CIRCUIT TESTING .....	7-7
Overload Protector .....	7-7
Motor Switch .....	7-8
Motor .....	7-8
WATER MIXING VALVE .....	7-8
WATER LEVEL SWITCH .....	7-9
SELECTOR SWITCHES .....	7-11
SAFETY SPIN SWITCH .....	7-11
<b>SECTION 8. SCHEMATIC DIAGRAM .....</b>	<b>8-1</b>
<b>SECTION 9. TROUBLESHOOTING .....</b>	<b>9-1</b>

---

## **SAFETY NOTES**

**PRECAUTIONS TO BE OBSERVED BEFORE AND DURING SERVICING TO AVOID POSSIBLE EXPOSURE TO EXCESSIVE DANGER AND ELECTRICAL SHOCK:**

- 1. Disconnect electrical supply before servicing machine.**
- 2. If electricity is required for a test:**
  - (A) First, disconnect electrical supply;**
  - (B) Second, make any connections or adjustments required for the test;**
  - (C) Third, connect electrical supply;**
  - (D) Fourth, perform the test. If service is required, disconnect electrical supply before servicing machine.**
- 3. Please use caution when servicing the machine with the front panel removed because there is danger of injury due to potential contact with spinning transmission.**
- 4. Please use caution when servicing the machine with the front panel removed because there is danger of injury due to contact with a potential "pinch point" between the turned up edge of the transmission cover and the tub support flange.**





# SPECIFICATIONS

<b>WASHER WEIGHT</b>	
Shipping - 185 pounds approximately	
Operating - 160 pounds approximately	
<b>DIMENSIONS</b>	
Width	27"
Depth	27"
Height to top of cabinet	35 3/4"
Height to top of control panel	44"
Height with door open	53 1/2"
<b>FINISH</b>	
Cabinet Top - powdered paint	
Clothes Door - powdered paint	
Outer Tub - constructed entirely of polypropylene	
Basket - polypropylene	
Cabinet - baked enamel	
Base and other finished parts - baked primer	
<b>DRAIN HEIGHT</b>	
32 inch minimum	
60 inch minimum	
<b>MOTOR</b>	
3/4 H.P., reversible, 115 volt, 60 cycle A.C.	
<b>TRANSMISSION</b>	
Rack and pinion type, incorporating reduction gears	

Setting	Gallons	*Depth Inches	*Basket Perforations
Mini	10.5	6"	3 1/2"
Medium	14.1	8 1/2"	5"
High	19.5	11"	7"
Super	23.3	13 1/2"	9 1/4"

\*Allowable variations are plus or minus 1/2 inch.

### **AGITATOR SPEED**

Regular Cycle	90 Oscillations per minute
Slow (Delicate) Cycle	60 Oscillations per minute

### **SPIN SPEED**

Regular Cycle	625 R.P.M.
Slow (Fine Wash) Cycle	416 R.P.M.

TABLE 0-1. AMPERAGE CHART		
CYCLE	WATER LEVEL	*AMPS
Agitate-Regular	Full Tub	10.4
Agitate-Slow	Full Tub	7.6
Agitate-Regular	Dry Tub	7.5
Spin-Regular	Dry Tub	10.2
Spin-Slow	Dry Tub	7.6
Pump Out-Regular	Full Tub	10.8
Pump Out-Slow	Full Tub	8.0

TABLE 0-2. RESISTANCE CHART	
COMPONENTS	*RESISTANCE (OHMS)
Timer Motor	2360
Mixing Valve	
Cold Solenoid	853
Hot Solenoid	867
Drive Motor	
High Speed	1.3
Low Speed	2.3
Start	3.1

\* These values can vary slightly.

TABLE 0-2. RESISTANCE CHART	
CYCLE	*WATTAGE RANGE
Agitate-Regular Full Tub	610-640 / 670 (MAX.)
Agitate-Slow Full Tub	370-400 / 420 (MAX.)
Agitate-Regular Dry Tub	460-470 / 480 (MAX.)
Agitate-Slow Dry Tub	350-360 / 370 (MAX.)
Pump Out-Regular	760
Pump Out-Slow	510
Spin-Regular Full Tub	460
Spin-Slow Full Tub	340

\* These will vary with washer load and line voltage.

---

## SPECIAL TOOLS

All special tools are manufactured by Robinaire with the exception of the 35-2442 Brake Removal Tool and 35-2968 Spanner Wrench - Basket Hub. These tools are privately manufactured for and stocked by Maytag Customer Service.

**NOTE:** The tools listed below can be ordered from any authorized Maytag Customer Service parts distributor.

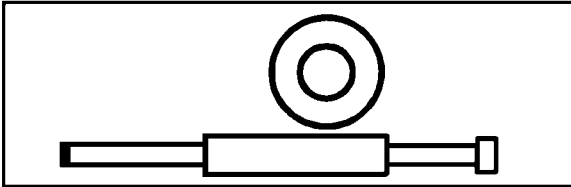

Transmission Seal Tool, Part Number 14242

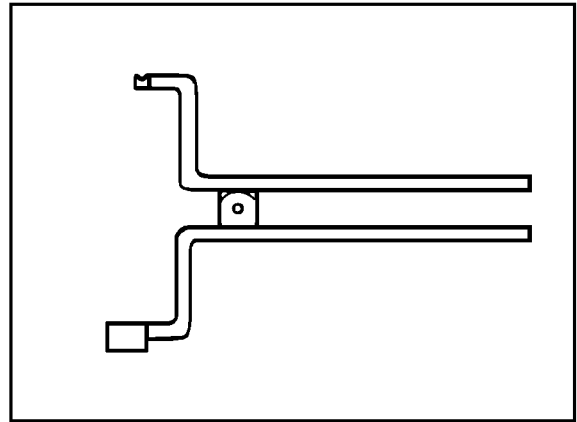

Spring Tool Kit, Part Number 21001138

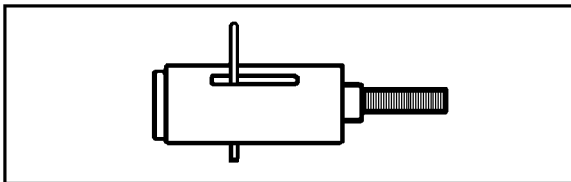

Brake Removal Tool, Part Number 35-2442

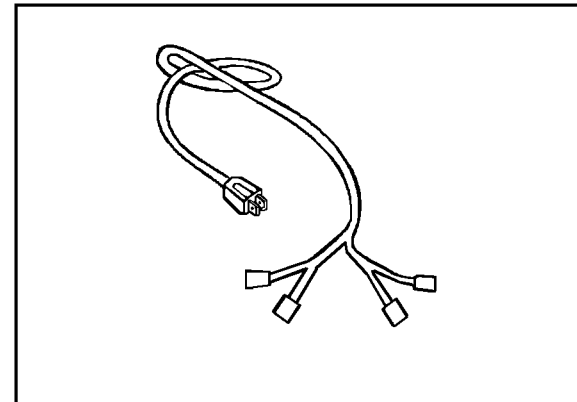

Motor Test Cord, Part Number 038183

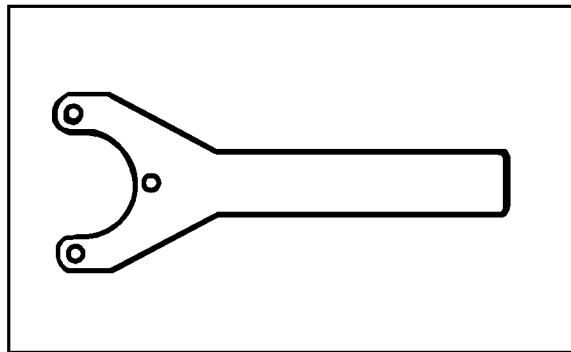

Spanner Wrench-Basket Hub, Part Number 35-2968



---

## SECTION 1. INSTALLATION

---

### PRE-INSTALLATION REQUIREMENTS

PLEASE READ ALL Installation Instructions and requirements before installing.

#### GENERAL INFORMATION

**DO NOT INSTALL THE WASHER ON A CARPETED FLOOR.**

**DO NOT INSTALL OR STORE THE WASHER WHERE IT WILL BE EXPOSED TO THE WEATHER.**

Installation in any location subject to freezing temperatures is not recommended. If the washer must be installed in such a location, it should be thoroughly drained after each use as follows:

- Turn off hot and cold water faucets.
- Disconnect both water inlet hoses at the faucets. Lower them to the floor.
- With the service cord connected to the electrical outlet, rotate the timer to the normal start or fill position and pull timer knob to start washer. Turn water temperature selector switch to warm.
- When water stops draining from the hoses, disconnect service cord.
- Lower the drain hose to the floor and allow it to drain into a floor drain or shallow pan.

In below-freezing temperatures, ice may form in the "fill" flume. Raise the room

temperature and allow time for the ice to melt before using the washer.

---

### Water Supply Requirements

1. Hot and cold water must be available at a pressure between 25 and 125 P.S.I. at the machine.
2. Shut off faucets with standard hose connectors should be available in both hot and cold water lines so that ***the water can always be turned off when the washer is not in use.***
3. The installation should be in accordance with local plumbing code requirements.

---

### Drain Requirements

A drain that will permit 23 gpm flow is required to evacuate the washer. A standpipe at least 32 inches high, but no more than 60 inches high, should be installed at the drain. The standpipe should have a 1 1/2 inch minimum internal diameter to prevent siphoning.

Tight connections between the drain hose and the drain (standpipe, etc.) are not recommended since they violate most local plumbing codes. In cases where a tight connection is required, an anti-siphoning valve, part number **33-4260**, should be placed in the drain hose to prevent siphoning from the washer or facility during agitation.

---

## Electrical Requirements

1. Provide an individual 120 volt, 60 HZ, branch circuit with ground for the washer. This circuit must be rated for 15 amperes or more.
2. Protect the washer's electrical circuit with a 15 ampere time delay fuse or circuit breaker.
3. Install in accordance with National Electrical Code and all local codes and ordinances.

## GROUNDING INSTRUCTIONS

The washer must be grounded. In the event of a malfunction or breakdown, grounding will reduce the risk of electrical shock by providing a path of least resistance for electrical current.

The washer is equipped with a power supply cord which has a grounding conductor and three-prong grounding plug. For proper grounding, the three-prong grounding plug must be plugged into an appropriate three-prong grounded receptacle or outlet (see the following figure). The receptacle must be properly installed and grounded in accordance with the National Electrical Code and all local codes and ordinances.

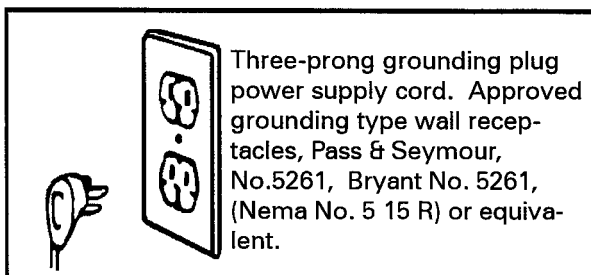

**WARNING:** *Improper connection of the grounding conductor or the three-prong grounding plug of the power supply cord may result in an electrical shock hazard. If there is any doubt as to whether the washer is properly grounded, have the installation checked by a qualified electrician.*

**DO NOT MODIFY THE PLUG PROVIDED WITH THE WASHER - If the plug will not fit the outlet, have a proper outlet installed by a qualified technician.**

---

## INSTALLATION PROCEDURE

To remove the carton, cut along the dotted line. Lift the carton and top cap assembly up and clear of the washer.

**NOTE:** *Retain the corner posts for later use.*

1. Untape and raise the washer lid; remove the items shipped in the spin basket. Save the literature for future reference. Close and tape lid.
2. Place three (3) corner posts and position them on the floor near the base of the washer. Place the remaining corner post on the floor approximately two (2) feet away. Carefully lay the washer on its back on top of the corner posts. **NOTE: A small amount of water may run from the pump due to factory tests. DO NOT LOWER OR RAISE THE WASHER BY THE CONTROL PANEL.**

- Pop the plastic loose from the screw located between the back feet, or remove the screw entirely with a screwdriver. Pull the plastic base away from the back feet. Grasping the plastic base on the sides, pulling downward to release the front feet from the slots and toward you to remove the base. Discard the base (it can be recycled). **RETURN THE WASHER TO THE UPRIGHT POSITION.**

### REMOVE SHIPPING BASE

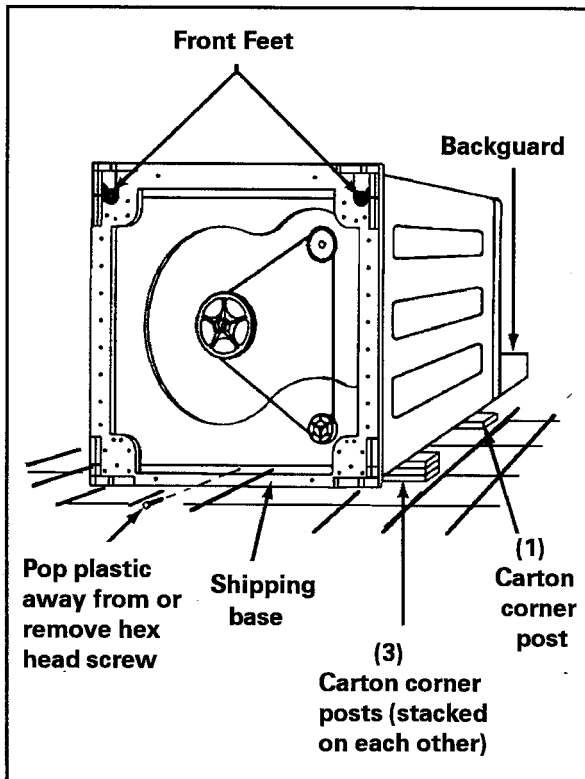

- Install the drain hose by placing the clamp over the hose (clamp provided in parts envelope). Push the hose onto the pump outlet of the washer. Be sure to position the hose in the direction of the standpipe. Squeeze the clamp ears with pliers, push the clamp up the hose and attach to the pump outlet.

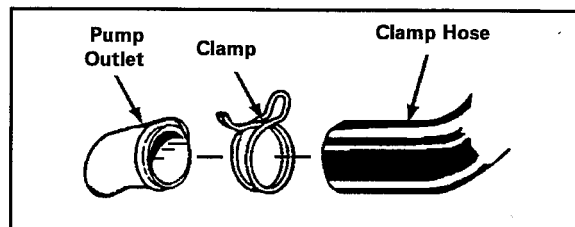
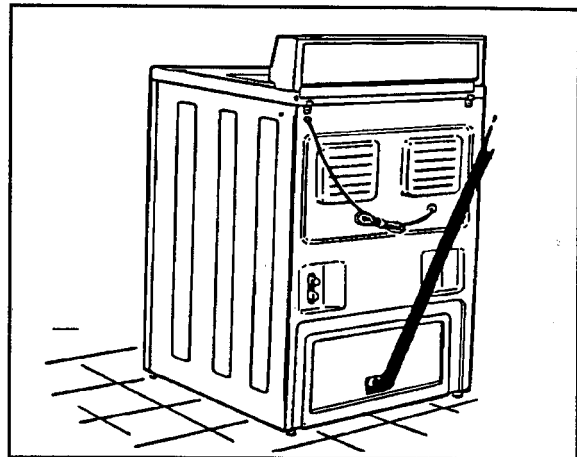

- Place a flat rubber washer on one end of the water hose, making sure the washers are pushed in tightly. Attach the hose end with the flat washer to the water mixing valve. Hot and cold connections are identified by H & C stamped in the cabinet. Tighten hose connections by hand until snug. Then, turn another 2/3 of a turn with the pliers.

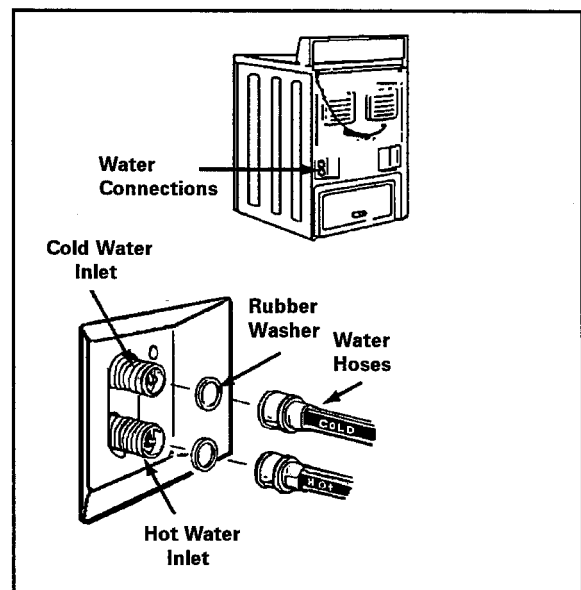

6. Move washing machine to the location where it will be used. A minimum of 1/4" clearance on all sides of the washer is recommended.

7. LEVELING AND/OR STABILIZING THE WASHER

### Stabilizer Model

*These models are equipped with self-adjusting legs on the rear which will automatically stabilize the unit.*

*The front legs are threaded and can be adjusted up and down to level the unit.*

#### Proceed as follows:

- Place the washer as close to its final operating location as possible.
- Make sure rear feet move up and down freely.

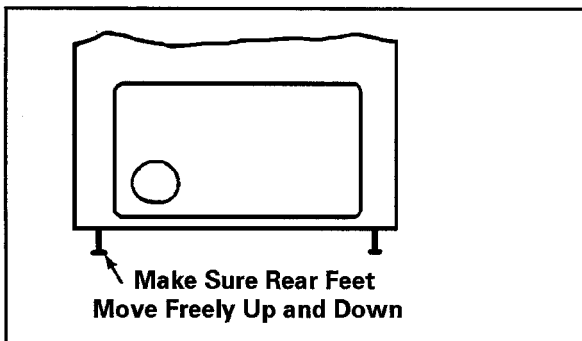

- Place washer in final location.

*Front foot adjustment for side to side leveling - Loosen the locknut, making sure it turns freely on the threads.*

- When the machine is in place, screw front feet out of base against the floor until the machine is acceptably level across the front.

- While holding foot still, turn the adjusting locknut clockwise until the nut is tightened firmly against base.

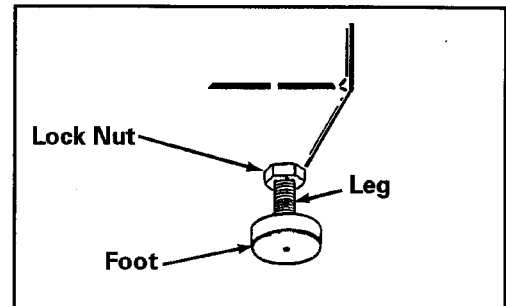

***Tilt machine forward until rear of cabinet is approximately 4 inches off the floor, then lower the machine back to the floor on the rear feet. This operation will cause the rear stabilizing feet to conform to the contour of the floor and seat them solidly. Rock washer with hands on opposite corners to check stability.***

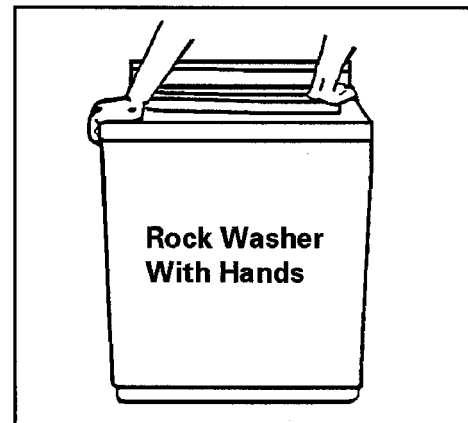

8. Place the gooseneck end of the drain hose into the standpipe or laundry tub. The drain hose should fit loosely in the standpipe to prevent siphoning. (An anti-siphon valve and associated parts are available from your dealer, part number 33-4294N).

**NOTE: BE SURE THE DRAIN HOSE IS NOT TWISTED OR KINKED.**



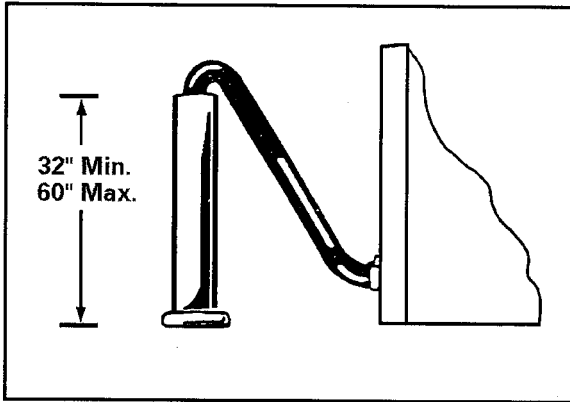

9. Insert the screens and washers (provided in the parts envelope) into the remaining ends of the water hoses. Attach the water hoses to the hot and cold faucets. **BE SURE HOT WATER INLET IS CONNECTED TO HOT WATER FAUCET.** Tighten by hand until snug, and then a 2/3 turn with pliers.

**DO NOT OVER TIGHTEN.** Turn on Faucets and check for leaks. Tighten to stop leaks if necessary.

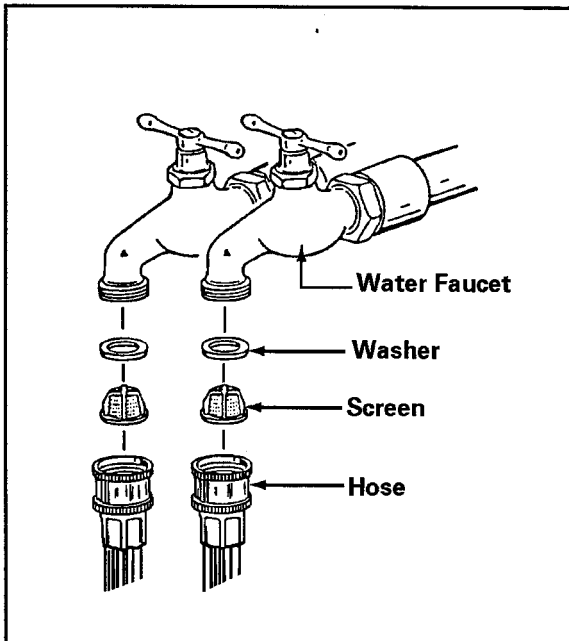

10. Plug the power cord into an outlet.
11. Start the washer in a spin cycle, per operating instructions, to center basket.
12. Start the washer in a wash cycle, as per operating instructions. Allow water to fill in machine until it reaches the level of the bottom row of holes in the wash basket. Then, stop the washer by pushing on timer knob.

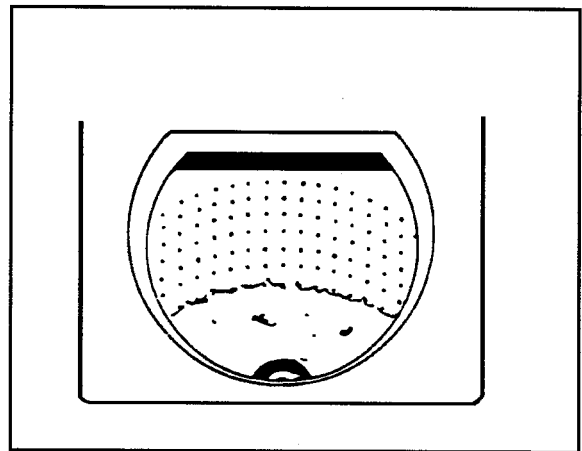

If the water is not level with the bottom row of holes all around the basket, readjust the leveling feet as required to level. Then remove the water by selecting a spin cycle.

#### FINAL CHECK OUT

1. Have all installation requirements been observed?
2. Have locknuts on front feet been tightened?
3. Are there any kinks in the hoses?
4. Are any water leaks evident?



---

## SECTION 2. OUTLINE OF MECHANICAL OPERATION

### GENERAL INFORMATION

The washer utilizes a reversible type motor which turns ***clockwise*** during the ***agitate cycle*** and ***counterclockwise*** during the ***spin cycle***.

**NOTE:** *The rotation directions as stated in this outline, are when viewing the component from its pulley end.*

A single belt is used to transmit power from the motor pulley to the drive and pump pulleys.

The drive pulley, which drives the transmission drive shaft and hub assembly, and the pump pulley which drives the pump impeller, are in operation whenever the motor is running.

The transmission assembly converts the power from the motor to either drive the agitator or spin the basket. The direction the clutch assembly rotates determines which action takes place.

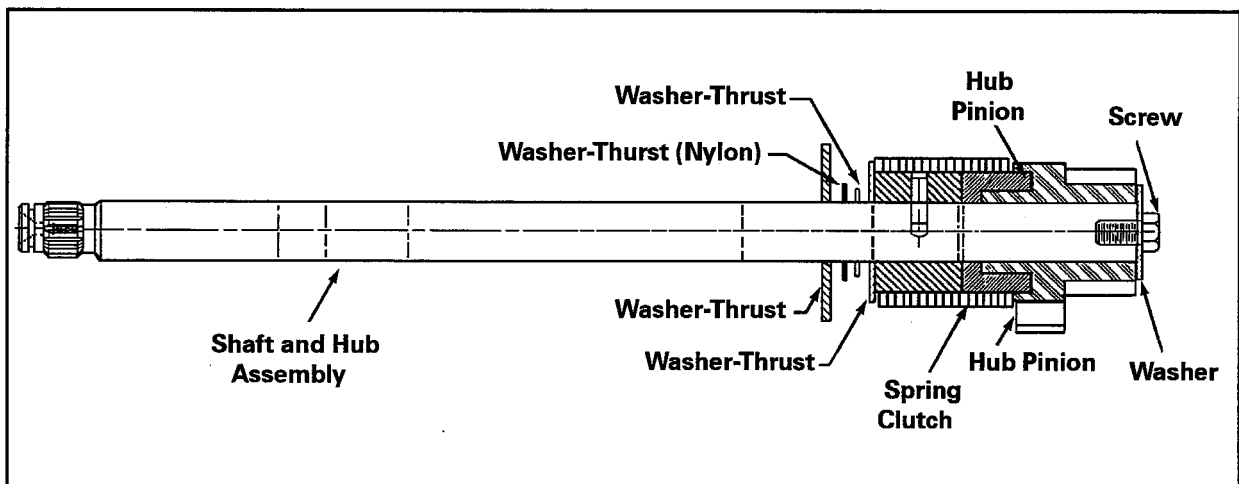

---

### CLUTCH ASSEMBLY

The clutch assembly consists of the drive shaft and hub assembly, clutch spring, and input pinion with gear lock assembly. The gear lock mechanism is part of the input pinion. The drive shaft serves only as a bearing surface for the drive pinion to revolve on. No direct drive is imparted from the shaft directly to the pinion. The inside diameter of the clutch spring is

designed so that when the drive shaft is driven in a clockwise direction, the clutch spring tightens on the two hubs and becomes a positive link between them. When the drive shaft hub runs counterclockwise, the clutch spring relaxes in an override situation. The override, or relaxed position, the clutch spring still maintains a drive link between the two

hubs. The override tension, or torque, is used to drive the spin basket. The gear lock mechanism consists of two "wings" that project out from the input pinion. When the drive pinion rotates in a clockwise direction, the gear lock mechanism exerts no force on the input pinion. When the input pinion starts to revolve counterclockwise the "wings" drop into dents in the lower housing preventing the pinion from turning.

---

## AGITATION

The clockwise (agitate) rotation of the drive shaft and the hub assembly is transmitted to the input pinion by the clutch spring. The input pinion meshes with the dual cluster gears which, in turn mesh with the dual crank gears. The circular motion of the dual crank gears are converted to the oscillating action of the agitator shaft by the dual rack gears. The rack gears have a stud that drops into the crank gears. These rack gears are contained by a rack carrier. Any tendency of the transmission to turn, or "creep", is prevented by the engaged brake assembly located on the under side of the suspension housing.

---

## SPIN

A nylon cam, along with a special drive pulley, provides a cam action which raises the drive pulley during the counterclockwise (spin) rotation of the motor. As the drive pulley hub moves up, it compresses a brake spring and lifts the brake rotor and lining assembly, disengaging it from the stator. The transmission is now free to spin.

The counterclockwise rotation of the drive shaft and hub assembly causes the clutch spring to relax into an override position. The clutch spring still exerts a driving force to the input pinion even when it is in the override position. As this driving force of torque starts to turn the input pinion in a counterclockwise direction, it causes the "wings" of the gear lock mechanism to drop into dents on the lower housing. This prevents the input pinion from revolving in the counterclockwise direction. Therefore, the torque being delivered by the clutch spring is exerted against the transmission housing, causing the entire assembly to rotate. The washer basket is mounted to the basket drive hub which is secured to the transmission cover assembly, and revolves as part of the transmission. In this direction, the pump assembly will drain the water out of the unit.

---

## SECTION 3. CABINET ASSEMBLY COMPONENTS

The components that comprise the cabinet assembly of the washer consists of: the cabinet body assembly, front panel, rear access panel, top assembly, base assembly, and the stabilizer assembly.

---

### CABINET BODY ASSEMBLY

The cabinet body assembly consists of a steel enameled "U"-shaped cabinet with a reinforcement brace welded across the upper front of the assembly.

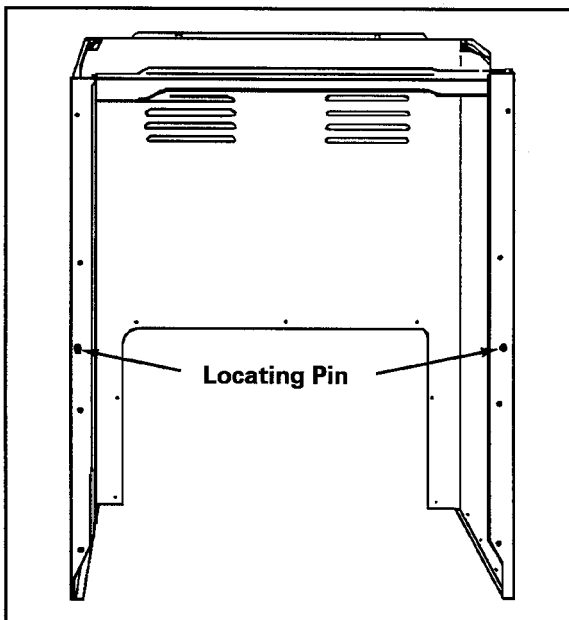

The cabinet body assembly provides mounting for the front panel, rear access panel, top assembly, water mixing valve, and the power cord.

The cabinet body assembly is attached to the perimeter of the base with ten (10) screws.

### REMOVAL:

1. **Disconnect the unit from the power source.**
2. Remove the top assembly as detailed later in this section.
3. Remove the front panel as detailed later in this section.
4. Remove the top hinges and power cord.
5. Remove inlet hoses from water mixing valve.
6. Remove rear access panel.
7. Remove water mixing valve.
8. Remove wiring clips and clamps from inner cabinet rear.
9. Remove the screws that secure the cabinet body to the perimeter of the base.
10. Open the front of the cabinet body slightly and push it off the rear of the base.

---

### Front Panel

The enameled steel front panel is attached to the cabinet body brace at the top, and secured at the bottom with base mounting clips. Locating pins on the cabinet front flanges position the front panel for assembly (*see illustration on the following page*).

The front panel provides mounting for the locating pins and top clips.

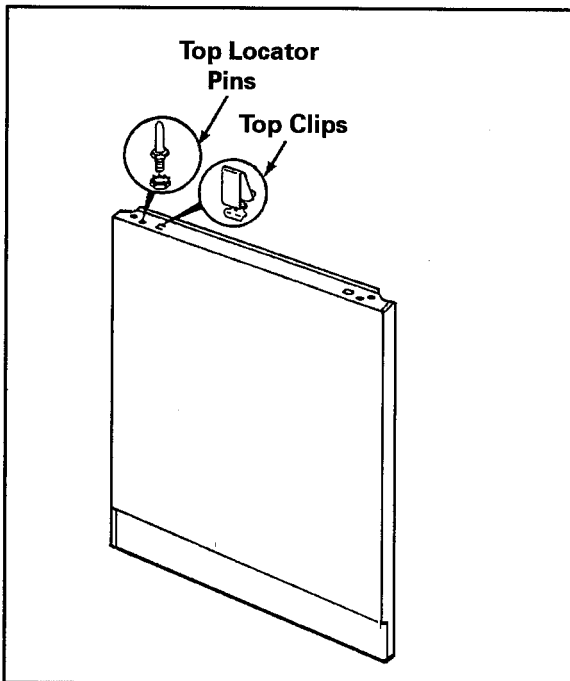

Front panel removal will allow access to the:

- Motor
- Motor Mount
- Motor Wiring
- Motor Pivot Spring
- Front Suspension Spring
- Tub Brace

**Removal:**

1. **Disconnect the unit from the power source.**
2. Insert a thin bladed tool between the front panel and the top assembly, approximately four (4) inches in from each corner. While lifting up on the top assembly, press the blade against the wire clips, one side at a time to disengage them.

3. After raising the top assembly, remove the two (2) screws which attach the front panel to the cabinet brace.
4. Tip front panel back to clear the locating pins on the cabinet front flanges. Lift the panel up and off the two (2) base mounting clips.

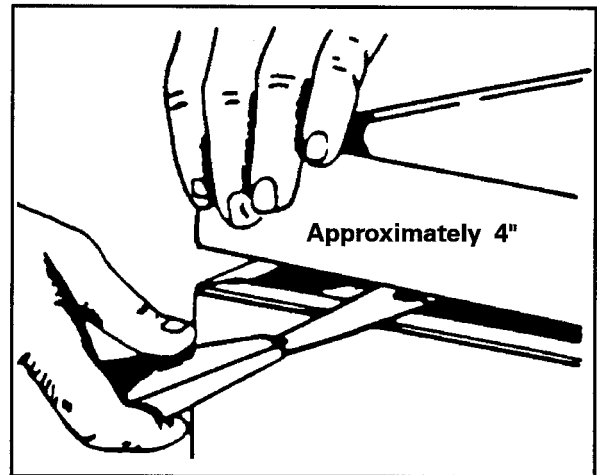

**Rear Access Panel**

The access panel is constructed of enameled steel and is attached to the cabinet rear by eight (8) hex head screws.

Panel removal will allow access to the:

- Stabilizer Assembly
- Water Mixing Valve
- Pump Assembly
- Rear and Side Suspension Springs
- Tub Braces

## TOP ASSEMBLY

The top assembly consists of the top panel, door assembly, safety spin switch and bracket, water inlet flume, insulating grommet, bleach dispenser, and the control panel assembly.

The assembly is mounted to the cabinet with two (2) steel hinges which are attached to the upper cabinet rear by two (2) screws. These hinges fit into slots located in the back edge of the top panel this allows the top assembly to be raised for servicing.

Two (2) holes pierced into the front flange of the top assembly align with two (2) locating pins to center the top assembly to the cabinet. Two (2) spring clips engage the top panel flange and secure the top assembly to the cabinet front.

**NOTE:** *The locating pins and top clips are mounted to the front panel flange on all models. (See the following figure).*

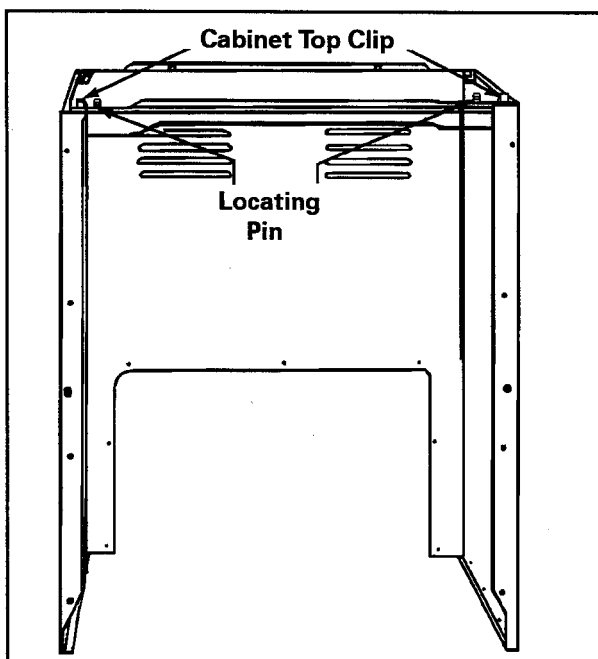

Raising the top will allow access to:

- **Door Hinge Mounting Screws**
- **Flume and Inlet Hose**
- **Safety Spin Switch**
- **Air Bell Hose Connection**
- **Control Panel Mounting Screws**
- **Power Cord/Harness Connection**
- **Water Inlet Valve Wiring**
- **Pressure Switch Hose Clamp**
- **Agitator**
- **Basket Assembly**

To raise the top assembly, insert a thin bladed tool (such as a putty knife) between the front panel and top assembly approximately four (4) inches in from each corner. Depress each spring clip while raising the top assembly.

### REMOVAL:

1. **Disconnect the unit from the power source.**
2. **Raise the top assembly and remove the flume inlet hose.**
3. **Lower top and remove the control panel rear shield.**
4. **Disconnect the pressure switch hose and all necessary wiring. Feed the hose and wiring through their respective top holes.**
5. **While pulling forward to remove, slightly raise the top assembly.**

---

## DOOR ASSEMBLY

The door assembly consists of the door panel, mounting hinges, plastic strike (switch actuator) and cushioning bumpers. The assembly is secured to the top panel by the two (2) mounting hinges.

When the door assembly is closed, the plastic strike (actuator) protrudes through a slot in the top panel and depresses a lever that actuates the safety spin switch.

---

## CONTROL PANEL ASSEMBLY (PAV1000AWW, PAV2000AWW)

### IMPORTANT

**The model/serial plate is located on top of the control panel assembly. When replacing the control panel, be sure to transfer the model/serial plate information to the new part.**

A typical control panel assembly, as shown by the *illustration on page 3-5*, consists of these components: control panel, knobs, end caps, clips, control shield, control panel shield, timer, switches and hood.

The control panel assembly is secured to the top by screws which pass up through the top panel and thread into the end cap clips. The assembly is further retained and supported at the rear by the control panel shield which is attached to the control panel, end caps and top flange.

The control panel is attached to the end caps at the bottom front and top, rear corners. The control shield, which provides the mounting for all controls, is also attached to the end caps.

---

## DISASSEMBLY

Before attempting to gain access to the controls mounted within the control panel assembly, place a protective cloth or pad on the cabinet top in front of the control panel to prevent scratches.

1. **Disconnect the unit from the power source.**
2. Remove the timer and selector knobs, as follows:
  - The timer knob threads onto the timer shaft and is removed by turning it in a counterclockwise direction.
  - Remove the selector knobs by pulling straight off.
3. Remove the three (3) screws which secure the rear top edge of the control panel to the end caps and control panel shield.
4. Remove the two (2) screws which secure the bottom front corners of the control panel to the end caps.
5. Lift off the control panel.
6. Remove the screws which secure the control shield to the end caps, and lay the front of the shield on the protective cloth. The control panel components are now accessible for testing and/or replacement.



7. The twist-mount switches require no screws to attach them to the control shield. Instead, the tabs formed on the face of the switch are inserted into specially formed cut-outs in the control shield. The rear of the switch is then rotated clockwise. This allows a spring tab, located on the switch, to interlock into a mating

cut-out in the control shield and secures the switch to the shield.

Switch removal is accomplished by disengaging the switch locking tab from the control shield cut-out and rotating the rear of the switch in a counterclockwise direction.

## CONTROL PANEL FOR PAV1000AWW, PAV2000AWW

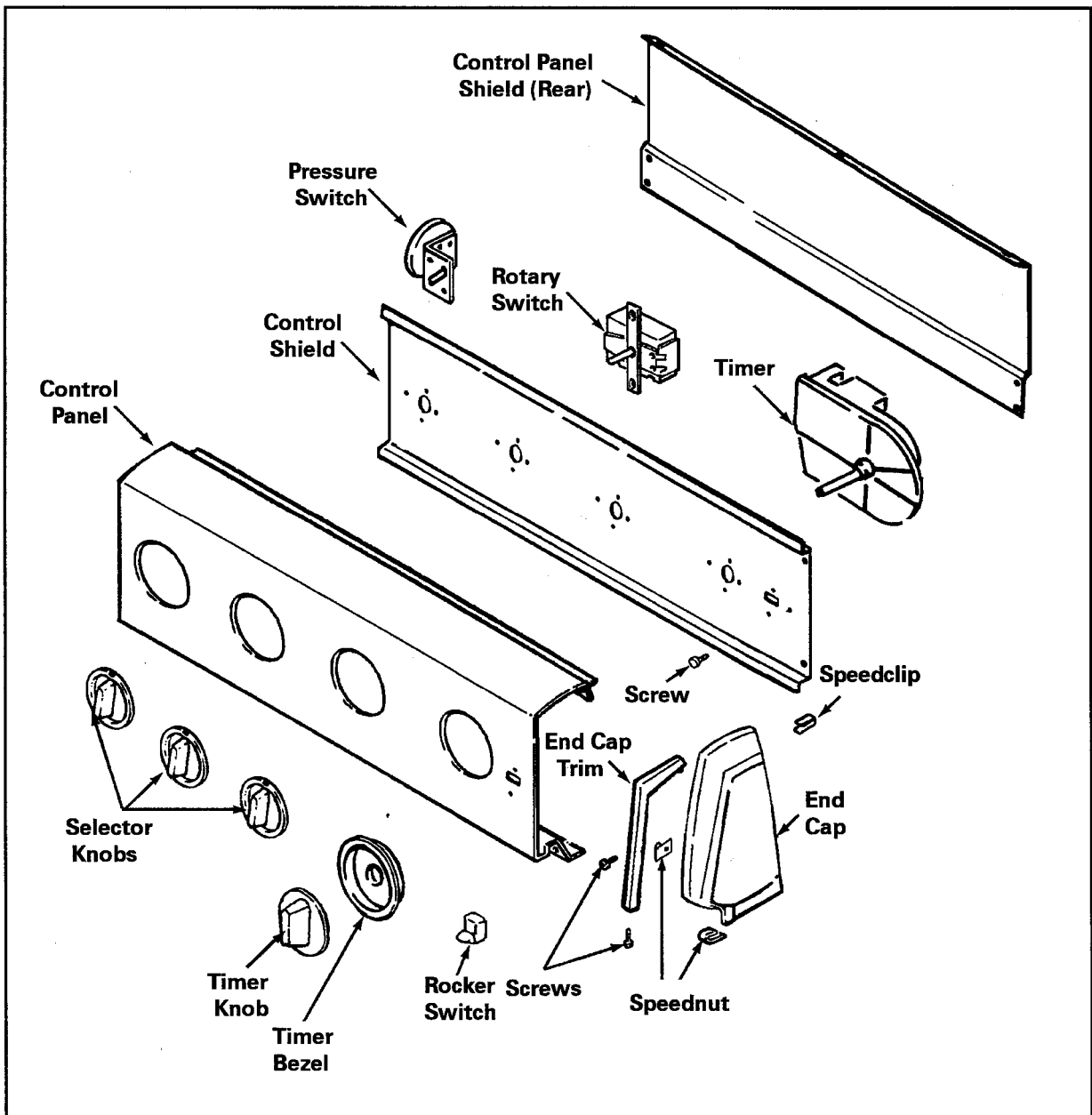

---

## CONTROL PANEL ASSEMBLY (PAV2200, 3200, 4200 Series)

### IMPORTANT

The model/serial plate is located on top of the control panel assembly. When replacing the control panel, be sure to transfer the model/serial plate information to the new part.

The control panel assembly on a low post drive system consists of end caps, frame, control panel, rear shield, control shield, knobs, timer and switches.

The frame and end caps are tabbed into the main top and are secured with screws at the top. They are further secured with screws at the rear through the rear shield into the main top. The control panel is tabbed into the frame at the bottom and held at the top by screws. The control shield, which provides the mounting for all switches, is mounted to the frame. The pressure switch is mounted directly to the frame.

---

## DISASSEMBLY

Before attempting to gain access to the controls mounted within the control panel assembly, place a protective cloth or pad on the cabinet top in front of the control panel to prevent scratches.

1. **Disconnect the unit from the power source.**
2. Remove the selector knobs by pulling straight off.

3. Remove the three screws which secure the rear, top edge of the frame assembly to the end caps and rear shield. This allows the frame assembly to roll forward exposing the internal components. Lay the frame assembly on the protective cloth. The control panel components are now accessible for testing and or replacement.

4. Remove the timer knob as follows:

Locate the hole with the timer knob shaft at the rear center of the timer. Using a small, flat blade screwdriver, pry the rod located in this hole up to release the timer knob. The knob and skirt will then pull straight off.

5. The timer is locked into the control shield with tabs molded into the body of the timer and held in place with one (1) screw. To remove the timer, remove the wiring harness plug. Remove the screw and gently pry up the tab located on the center of the timer body below the wire harness and slide toward the inside of the machine. This releases the timer from the control shield.
6. The twist-mount switches require no screws to attach them to the control shield. Instead, the tabs formed on the face of the switch are inserted into specially formed cut-outs in the control shield, then the rear of the switch is rotated clockwise. This allows a spring tab, located on the switch, to interlock into a mating cutout in the control shield and secures the switch to the shield. Switch removal is accomplished by disengaging the switch locking tab from the control shield cut-out and rotating the rear of the switch in a counterclockwise direction.

# CONTROL PANEL FOR PAV2200, 3200, 4200 SERIES

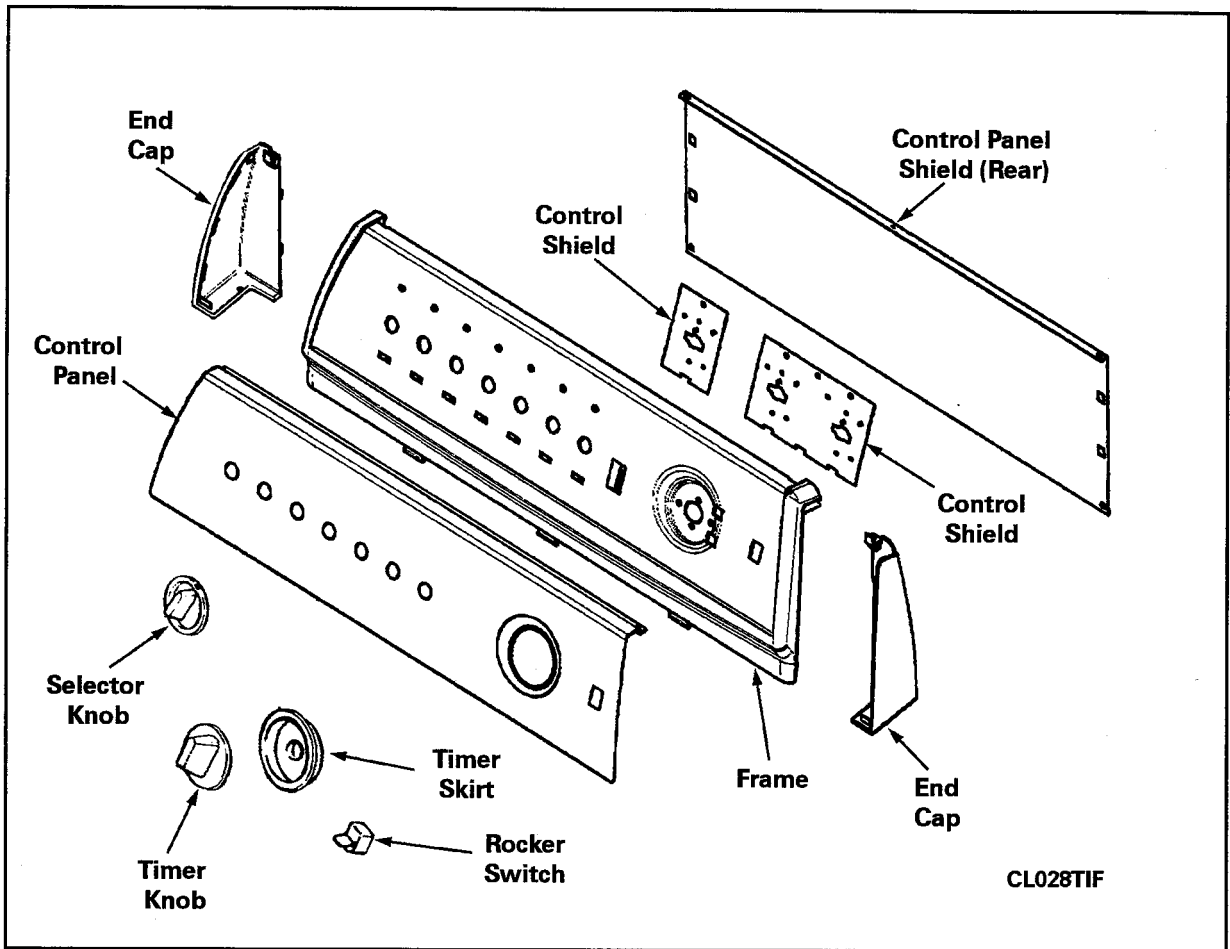

## BASE ASSEMBLY

The base assembly, which serves as a support for the entire wash unit, is constructed of heavy gauge metal that has been flanged and embossed for strength.

A suspension housing with a spherical configuration is assembled to the lower portion of the wash unit. This suspension housing rides on the raised, dome-like

snubber area in the center of the base. The mounting is similar to a ball joint and allows the housing to move freely in all directions.

The base assembly also provides mounting for the pump assembly, motor and plate assembly, suspension springs, front panel clips, and the stabilizer assembly.

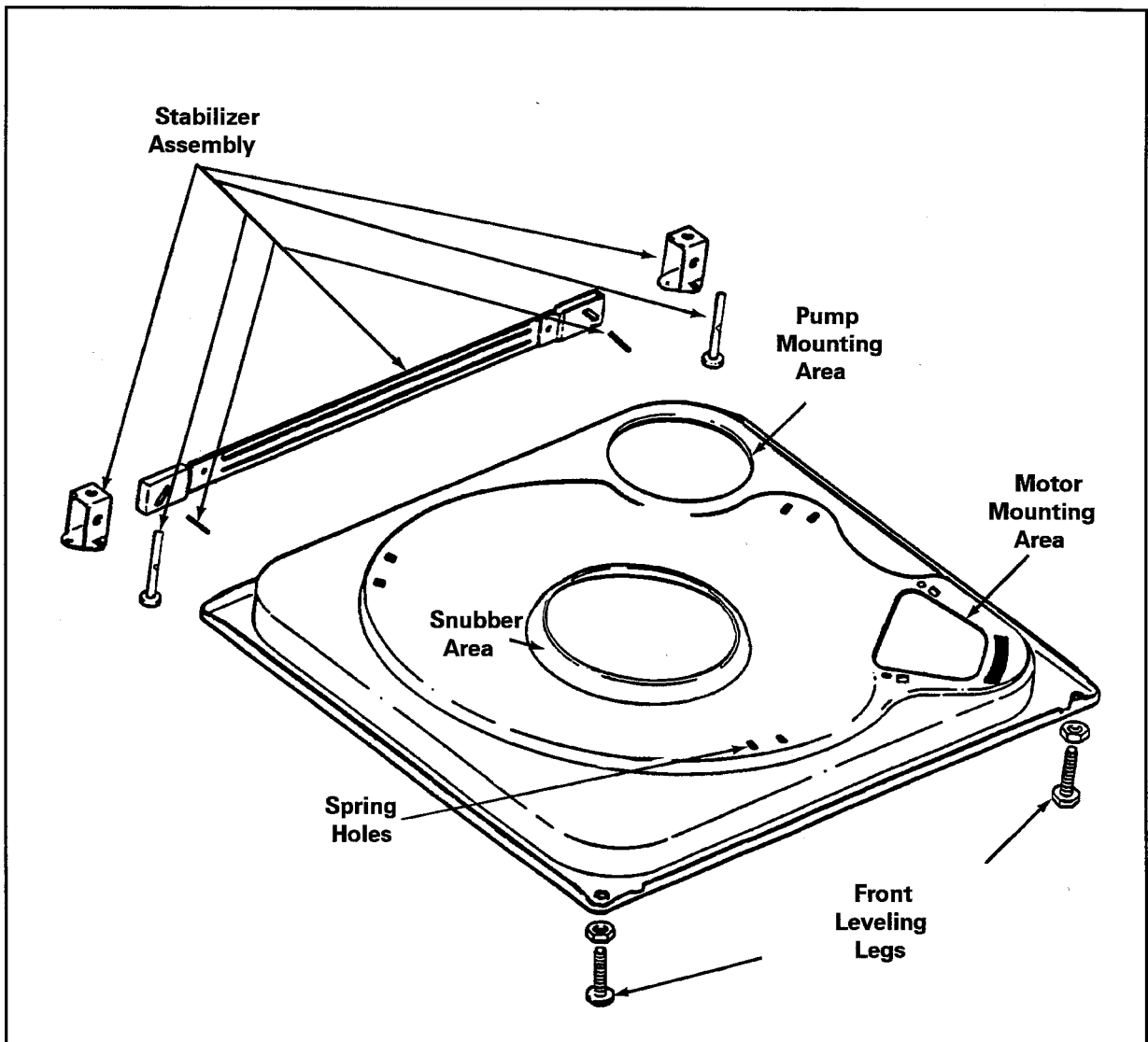

The cabinet is secured to the base by cushioned screws to prevent vibration or noise transfer. The cabinet does not support any of the wash unit's weight.

### BASE REPLACEMENT:

1. **Disconnect the unit from the power source.**
2. Tip unit and remove the drive belt.
3. Disconnect the inlet hoses from the water mixing valve.
4. Remove the access panel from the cabinet rear and disconnect the discharge hose from the pump outlet.
5. Remove the top assembly.
6. Remove the front panel.
7. Disconnect lower wiring from the cabinet rear (water mixing valve, power cord, etc.) and remove pressure switch hose from tub air bell.
8. Remove the screws attaching the cabinet to the base.
9. Push the front of the cabinet slightly and push or pull it off the rear of the base.
10. Disconnect the pump hose from the tub outlet and remove the pump assembly and hose from the base.
11. Remove motor mounting screws, ground wire and wiring clips from base. Lift the motor and plate assembly from the base with the wiring harness attached.
12. Remove the suspension springs and lift the complete wash unit from the base.
13. Remove the stabilizer assembly from the base assembly, as detailed later in this section.
14. Transfer the remaining hardware from the defective base to the replacement.
15. Installation is a reversal of the above procedure.

### STABILIZER ASSEMBLY

The stabilizer assembly consists of the stabilizer bar assembly, two (2) stabilizer brackets, two (2) self-stabilizing feet, and two (2) foot pins. It is mounted on the top rear of the base assembly.

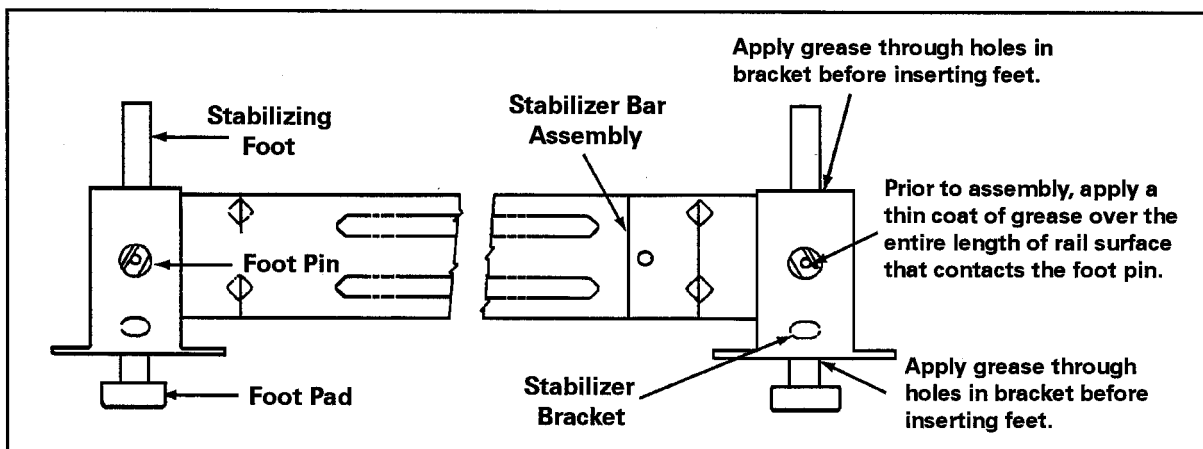

The stabilizer assembly allows the base assembly to rest solid and firm against the floor, even if the floor is unlevel. The solidity of the base to the floor keeps the washer from rocking back and forth or "walking" during operation.

As the name implies, the stabilizer only stabilizes the unit; it does not level it. Any leveling that is required must be done with the front adjusting (leveling) legs.

In rare cases where the floor is so uneven that it is beyond the stabilizing limit of the assembly (+ or - 5/8"), it may be necessary to remove the stabilizer assembly and install two (2) rear adjustable feet. Two (2) threaded holes have been provided in the rear corners of the base for this situation.

---

## Removing the Stabilizer Assembly:

1. **Disconnect the unit from the power source.**
2. Remove the access panel from the cabinet rear.
3. Tip or lay washer down and remove the screws from the underside of the base that attaches the stabilizer assembly to the base.
4. Remove the stabilizer assembly through the rear access panel.
5. To disassemble the stabilizer assembly after removal, drive the two (2) foot pins out of the feet and brackets.

**NOTE:** *In order for the stabilizer assembly to operate properly, a thin coating of grease must be applied over the entire length of the four (4) pin guides as well as the foot holes in the bracket. (See the stabilizing assembly figure on page 3-8.)*

## SECTION 4. WATER RELATED COMPONENTS

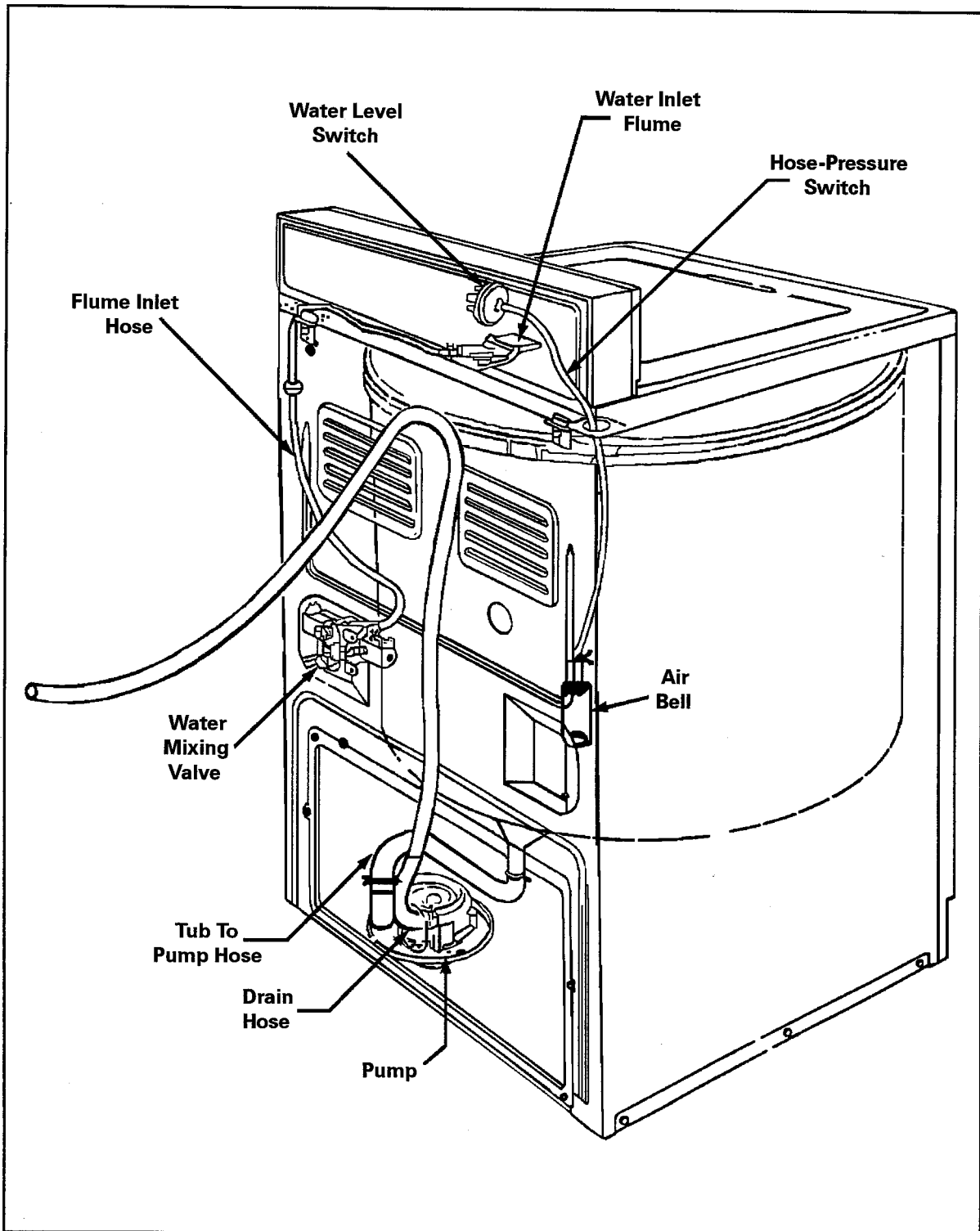

## WATER MIXING VALVE

The water mixing valve is located inside the right rear cabinet. It is secured by two (2) screws inserted through the cabinet into the valve bracket. The hot and cold water supply inlet hoses are attached to the nozzles of the water mixing valve.

The mixing valve will allow hot or cold water, or a mixture of the two as

called for by the control circuitry, to enter the machine through the inlet hose and inlet flume.

Usually, the temperature of the warm water entering the machine will be about halfway between the cold and hot water temperatures delivered to the mixing valve. This is provided the pressure and flow rate of both are equal.

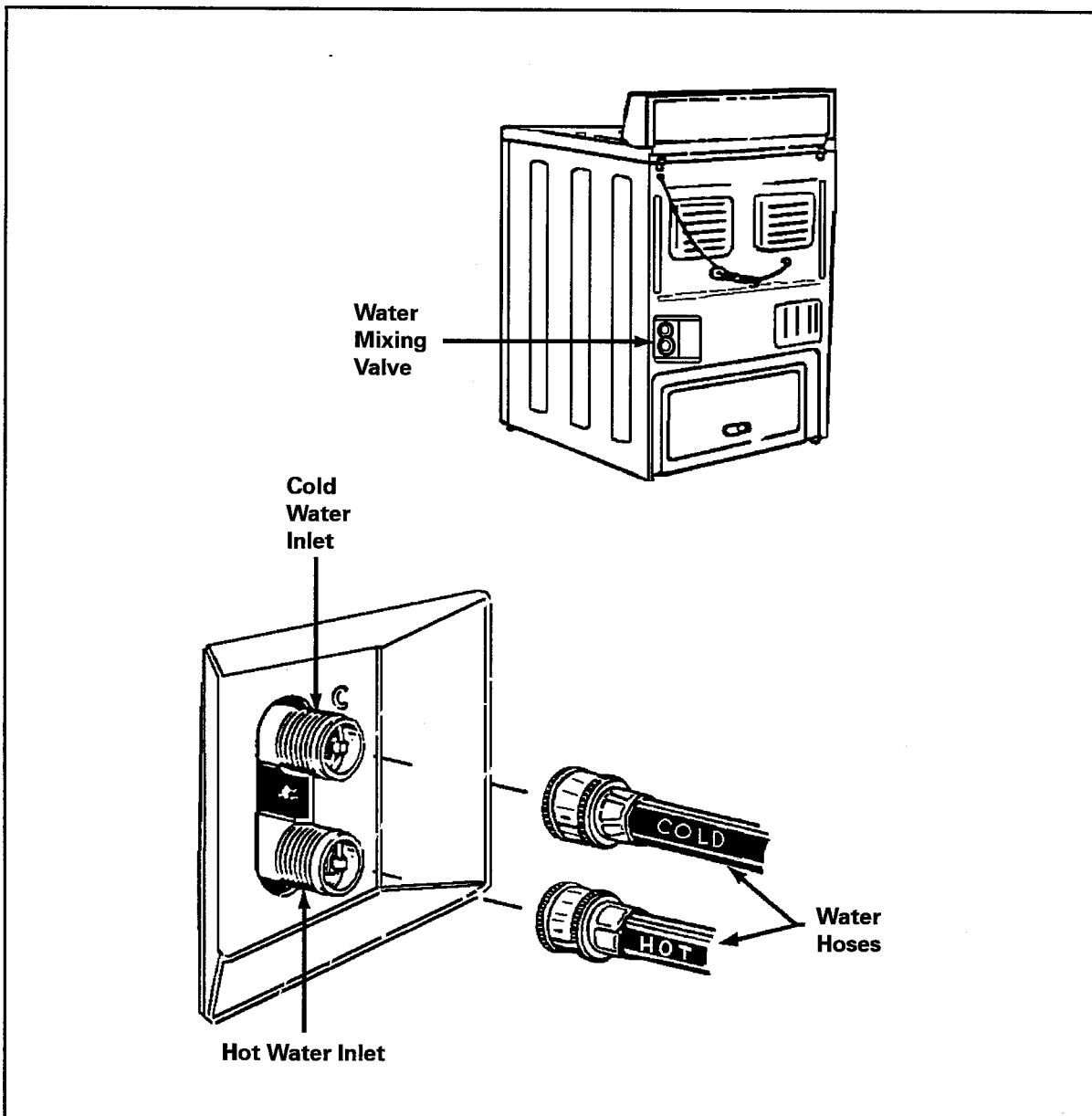



---

## WATER INLET FLUME

The molded plastic water inlet flume consists of an upper and lower section that have been snap-locked together. This forms a water tight assembly with a built-in siphon break.

The flume is located on the rear underside of the washer top assembly. The flume fits flush with the top opening and is secured to the top by two (2) mounting screws. An inlet hose from the water mixing valve connects to the flume nozzle.

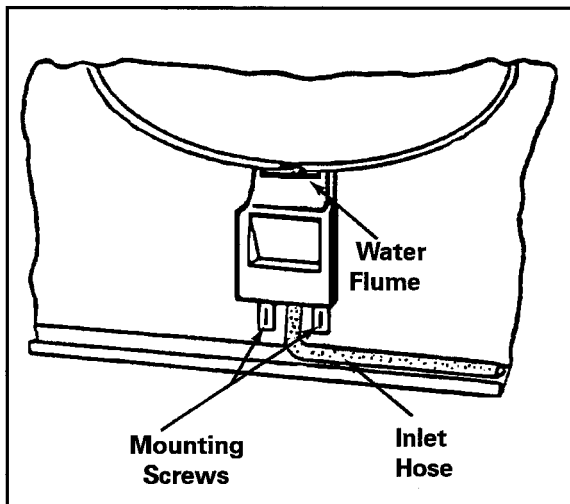

---

## AIR BELL

A polypropylene air bell and nipple assembly has been thermally welded to the rear of the lower, outer tub. One end of the pressure switch hose connects to the air bell nipple and the other end is attached to the water level switch.

As the water level rises in the tub, it compresses the air in the air bell nipple and the attached hose. When the water level has been reached the compressed air inside the hose will activate the pneumatically-operated water level switch.

The lack of compressed air will also reset the switch during the drain cycle.

**NOTE:** *When reinstalling the pressure switch hose, make sure the system is free of air leaks and water in the hose or an overflow condition will occur.*

---

## HOSES

### Water Supply Inlet Hoses

Two (2) water inlet hoses attach from the hot and cold water supply lines to their respective nozzles on the water mixing valve. They are secured at both ends with threaded couplings.

### Flume Inlet Hose

The flume inlet hose attaches the water mixing valve to the water inlet flume. It is secured at both ends with spring type-hose clamps.

### Pressure Switch Hose

The pressure switch hose is made of soft plastic tubing and fits snugly over the water level switch nipple at one end, and the air bell nipple at the other. A clamp on the inner cabinet rear positions the hose. A pad prevents the hose from contacting the back of the cabinet during operation. The hose is installed with its ends butted against the switch and air bell bodies. It is secured at both ends with a spring-type hose clamp.

### Tub to Pump Hose

The tub-to-pump hose attaches from the drain nipple on the tub to the pump inlet nozzle. It is secured at each end with a spring type hose clamp.

## Drain Hose

The drain hose attaches the pump outlet to the drain standpipe. It is secured to the pump with a spring-type hose clamp.

---

## TUB TOP

The tub top is constructed of molded polypropylene. It is secured to the tub by eight (8) tabs which have been formed around its periphery. These tabs snap over mating tab locks which are molded around the upper sides of the tub.

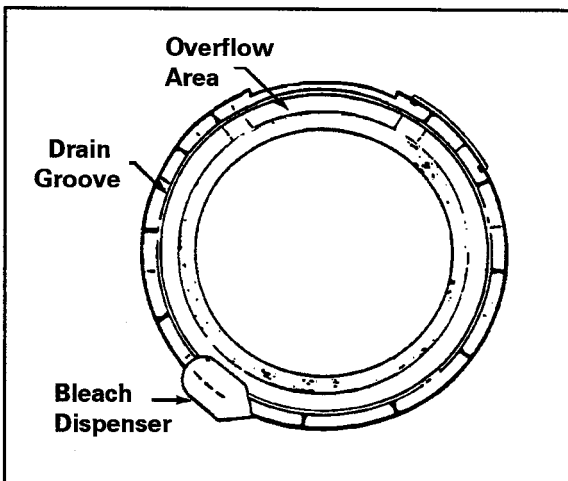

Designed into the tub top is a drain groove, an overflow area, and a bleach dispenser. In case water should splash out of the basket during machine operation, the **drain groove** directs the water back into the tub. The **overflow** area is located at the tub top rear and will direct any overflow water away from the drive motor. The **bleach dispenser** is functional only when used in conjunction with the proper cabinet top assembly which is available on designated models.

A foam seal has been installed in a groove on the underside of the tub top.

The seal provides a water seal between the tub and the tub top.

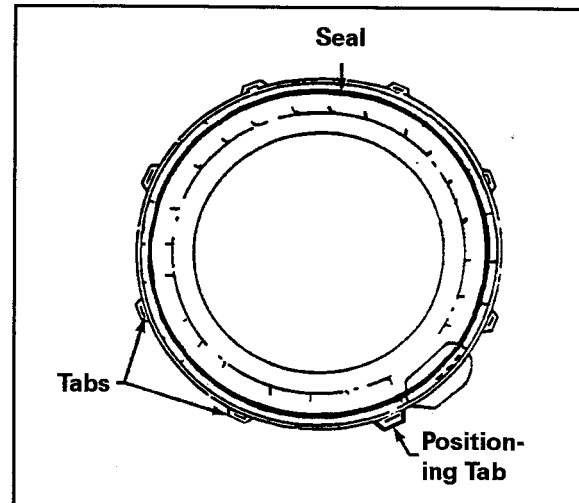

It is necessary to remove the tub top before removing the spin basket. To remove the tub top, push down on it while disengaging the tabs from the tab locks on the tub.

**NOTE: When reinstalling the tub top, please observe the following:**

1. Make sure the foam seal is in place on the underside of the tub top.
2. Align the tab on the tub top having the larger opening with its mating tab lock on the tub, and lock it down around the tub. This seals the top.

---

## AGITATOR (PAV1000AWW, PAV2000AWW)

The agitator is a four-vane design molded from a polypropylene compound. It is tough flexible material, highly resistant to breakage. The agitator is mounted on the splined top of the agitator shaft and secured with the agitator retaining screw and washer. A plastic agitator cap snaps over the top of the agitator.

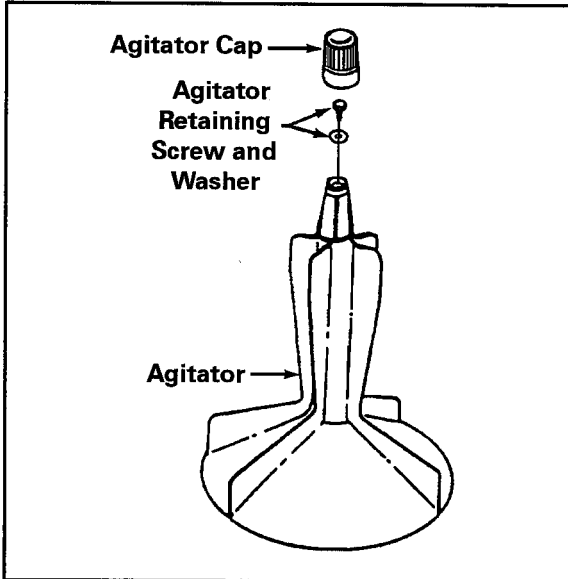

## AGITATOR (PAV2200, 3200, 4200 Series)

The agitator on the low post drive is a two piece, four vane design molded from polypropylene compound. It is a tough flexible material, highly resistant to breakage. The agitator lower half is mounted on the splined top of the agitator shaft. The upper half of the agitator snaps onto the lower half and is secured with the agitator retaining screw and washer. A plastic agitator cap or fabric softener dispenser is placed on the top, depending on the model.

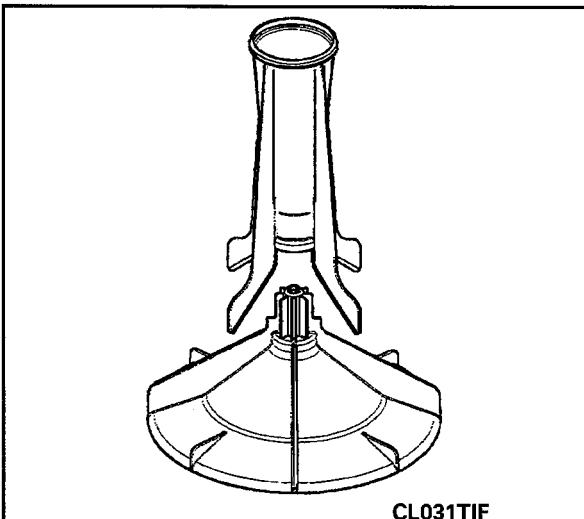

## SPIN BASKET

The spin basket is perforated in a pattern designed to allow free flow of the wash and rinse water for maximum efficiency in removing sediment, soil deposits, and lint.

The spin baskets are constructed entirely of polypropylene and are secured to the basket hub assembly with four (4) mounting screws.

A foam gasket is installed between the basket and the basket hub assembly.

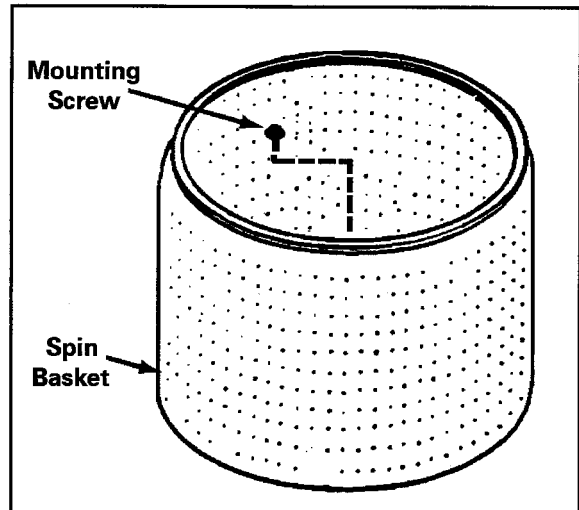

### REMOVAL:

1. **Disconnect the unit from the power source.**
2. Raise the top assembly and lean it back.
3. Remove the tub top.
4. Remove the agitator.
5. Remove the mounting screws.
6. Lift the spin basket up over the center post and out of the cabinet.

**NOTE: When reinstalling the spin basket, be sure to:**

- Clean all connecting surfaces to ensure proper sealing.
- Position the basket on the basket hub assembly.
- Align the assembly and tighten all screws securely.

---

## OUTER TUB ASSEMBLY

The outer tub assembly is molded entirely of polypropylene and consists of the tub, top locks, air bell, and drain nipple.

The tub assembly is mounted to the bearing and seal housing and to the tub support. A foam gasket and a rubber seal are installed between the tub bottom and the bearing and seal housing.

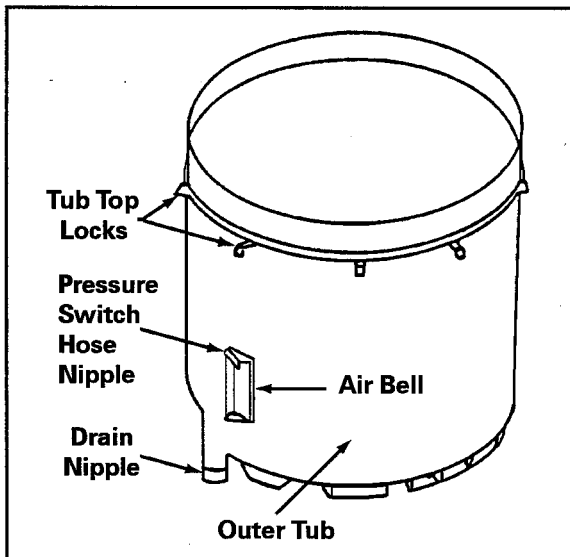

### REMOVAL:

1. Disconnect the unit from the power source.
2. Remove the spin basket.

3. Remove the front panel.
4. Remove the rear access panel.
5. Disconnect the pump inlet hose from the tub drain nipple.

**NOTE: The nipple is somewhat fragile.**

6. Remove the screws located on each side of the tub brace bolts which secure the tub to the tub support.
7. Remove the mounting screws on the inside of the tub which mount the tub to the bearing and seal housing.
8. **PROTECT THE AIR BELL NIPPLE** and lift the tub from the cabinet.

**NOTE: When reinstalling the tub assembly, be sure to:**

- Protect the air bell nipple.
- Clean all connecting surfaces to ensure proper sealing.
- Position the gasket and seal on the bearing and seal housing.
- Tighten all screws securely.

## PUMP ASSEMBLY

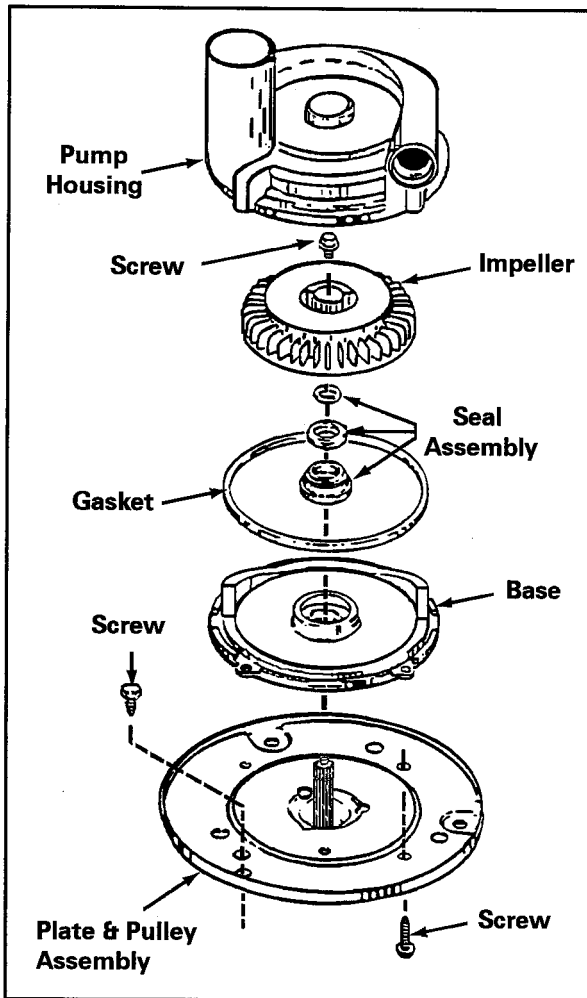

The pump assembly is located on the right rear corner of the washer base.

The pump pulley is engaged to the drive belt at all times and will be operating in both motor directions: Clockwise during agitation and counterclockwise during spin. However, the pump is designed so it will only discharge water from the machine when it is running in the counterclockwise, or spin direction.

### REMOVAL:

1. Disconnect the unit from the power source.

2. Remove the drain hose from the pump outlet.
3. Remove the rear access panel from the cabinet rear.
4. Disconnect the pump inlet hose.
5. Remove the three (3) screws which mount the pump assembly to the base.
6. Slide the pump forward to disengage the belt from the pulley.

**NOTE:** *If this is done carefully, the belt will remain on the motor and transmission drive pulley, making installation easier.*

### REINSTALLING:

Place one hand through the pump opening and lift belt. Set the pump pulley into the opening and place the belt on the pulley. While holding tension on the belt to keep it on the pulleys, install the mounting screws.

### DISASSEMBLY:

1. Remove the pump from the washer base.
2. Remove the four (4) screws that secure the housing to the pump base, and lift off the housing.
3. Remove the screw that secures the impeller.
4. Using two (2) screwdrivers, one on each side of the impeller, carefully pry the impeller off the spline shaft.
5. Work the seal mating ring and "O" ring up and off the shaft.



## SECTION 5. SUSPENSION SYSTEM

The washer utilizes a six (6) point suspension system which consists of the suspension housing, snubber pad, tub braces, suspension springs and related hardware.

The six (6) point system features six (6) lighter duty springs. Three (3) springs are installed between the base and the top of the tub brace. The other three (3) are between the base and special spring hooks attached to the tub support perimeter.

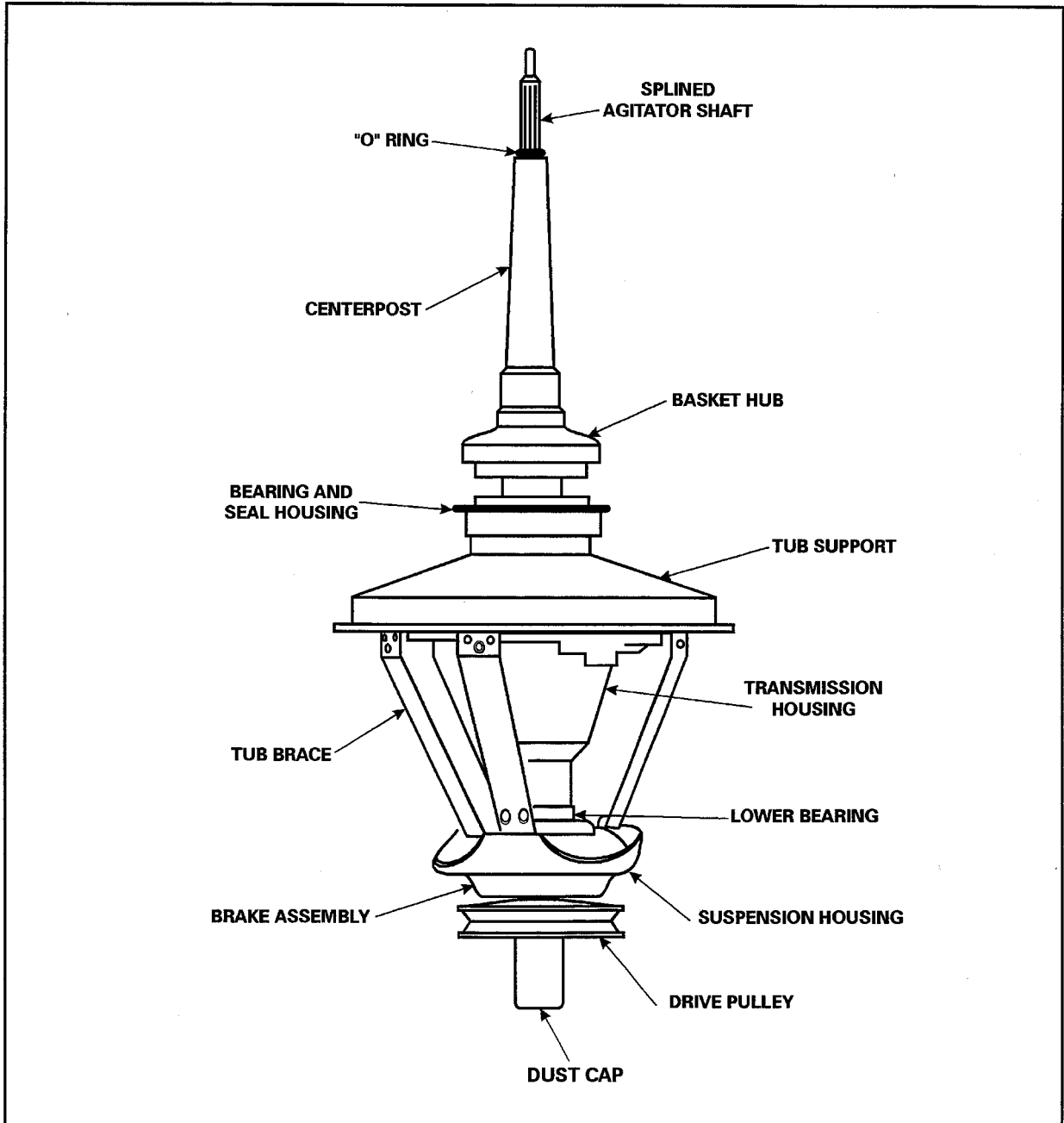

## SUSPENSION SYSTEM (PAV2200, 3200, 4200, SERIES)

The low post system washer utilizes a six (6) point suspension system which consists of the suspension housing, snubber pad, tub braces, suspension springs and related hardware.

The six (6) point system features six (6) lighter duty springs. Three (3) springs are installed between the base and the top of the tub brace. The other three (3) are between the base and special spring hooks attached to the tub support perimeter.

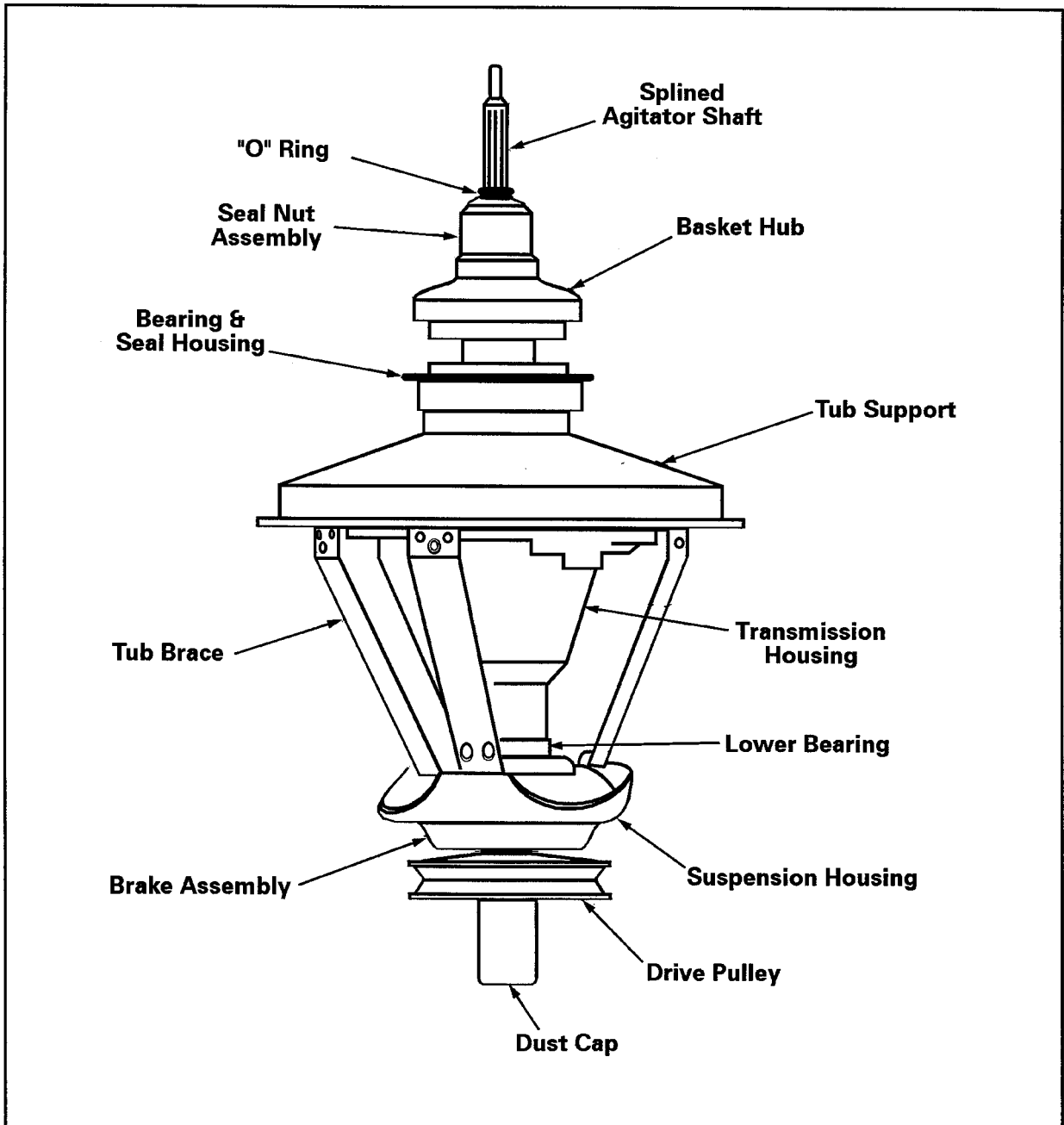



---

## SUSPENSION HOUSING

The suspension housing is fabricated of heavy gauge steel. It rests on the raised, dome-like area in the center of the base and supports the weight of the transmission, outer tub, and spin basket.

The underside of the suspension housing provides mounting for the snubber pad and also houses the brake assembly.

The bottom of the housing has been formed into a spherical configuration and, along with the snubber, rides on the domed area of the base which allows the housing to move freely in all directions.

The top of the suspension housing is attached to the lower bearing assembly with three (3) mounting screws. These screws thread from the underside of the suspension housing dome into the die-cast bearing housing.

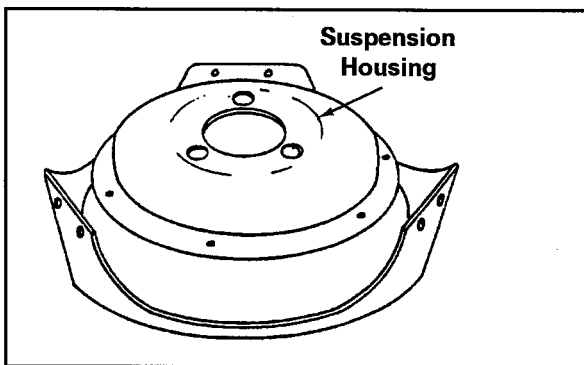

Service to the suspension housing, other than replacing it, is limited to replacing one of the other components that mount to the housing. The replacement procedures for these components are detailed in the **Transmission Section** of this manual.

## REMOVAL:

1. **Disconnect the unit from the power source.**
2. Remove the transmission assembly as detailed in **Section 6**.
3. Remove the brake assembly as detailed in **Section 6**.
4. Remove screws securing housing to the lower bearing assembly.

---

## TUB BRACES

The tub braces are attached at the top to the tub support, and to the suspension housing at the bottom. The tub braces are located **behind** the tub support and suspension housing where large, thread forming screws are driven directly into the braces to secure them.

**NOTE:** *Should a tub brace mounting screw hole become stripped, a nut can be installed on the thread forming screw.*

The extended end of the suspension spring fits through an extruded hole in the tub brace just below the mounting screws.

---

## SUSPENSION SPRINGS

The suspension springs hold the entire wash unit in firm contact with the base. To reduce wear and prevent squeaks; grease has been applied to the friction points of the springs.

## REMOVAL:

The suspension springs can be removed and replaced by using the spring tool, part number **21001138**, as follows:

1. **Disconnect the unit from the power source.**
2. Remove the front panel and rear access panel.
3. Pull or block the tub in the direction of the spring to be removed. Place the round end of the tool against the base of the unit and extend the spring. Care must be used not to over-extend the springs.

**NOTE:** *Removing the tub top will allow the tub to travel further and extend the spring even more.*

4. Spring replacement is a reversal of the above.

**NOTE:** *Be sure to grease the friction points of the replacement springs before installing.*

## IMPORTANT

*No attempt should be made to remove or install the springs with pliers, vise-grips or anything other than the spring tool, as damage to the springs will probably occur. When attaching the springs to the base for installation, make sure the spring end is protruding up through the small triangular cut-out next to the deboss.*

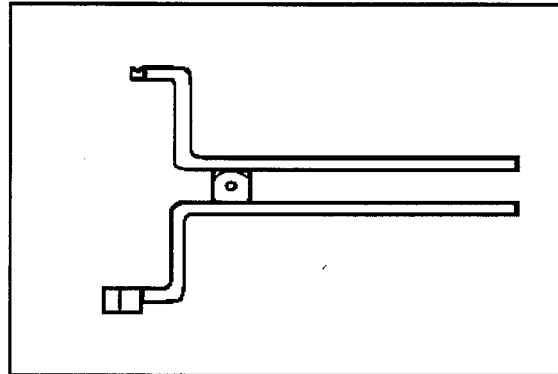

**SPRING TOOL KIT  
PART NUMBER 21001138**

## SECTION 6. TRANSMISSION AND RELATED COMPONENTS

This section will detail the servicing procedures on the transmission assembly which has splines formed on the agitator drive shaft. An "O" ring is installed on the shaft just above the center post to provide a center post seal when the agitator is installed.

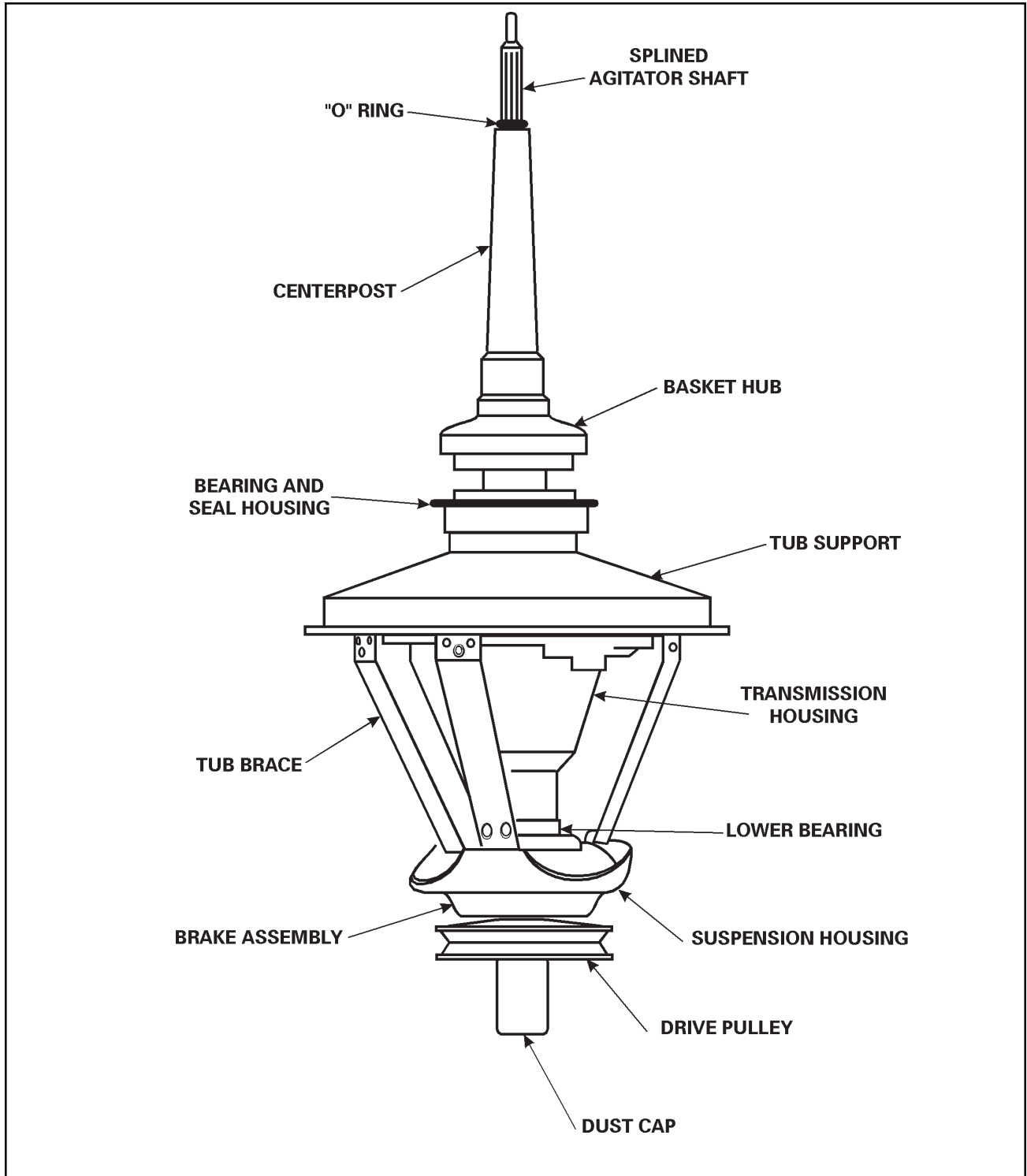

---

## CENTER POST ASSEMBLY

The center post assembly consists of a plastic center post. A nylon agitator bearing slips over the lower portion on the center post body.

The center post assembly is secured to the basket hub assembly by the spin basket, and to the agitator shaft. A small rubber gasket is installed in a groove on the bottom flange of the center post, and a foam gasket is placed between the bottom of the spin basket and the basket hub assembly.

The center post can be removed after removing the spin basket, and the agitator shaft "O" ring.

---

## BEARING AND SEAL HOUSING

The die-cast bearing and seal housing slips over a machined area on the lower drive tube. The basket hub assembly threads downward over the drive tube and secures the bearing and seal housing.

The spin bearing and the tub seal are installed in a cavity in the center of the housing. The sheet metal tub support is attached to the under side of the housing with three (3) mounting screws. The spin bearing has been pressed into the underside of the housing cavity and is secured by the tub support.

The center of the tub assembly mounts to the upper flange of the housing with a tub gasket and a tub seal installed between. The bottom of the tub sits on, and is attached to, the tub support.

## REMOVAL:

1. **Disconnect the unit from the power source.**
2. Remove the agitator, spin basket, tub assembly, and center post.
3. Remove the Seal nut with 2202898 and 35-2968
4. Remove the basket hub assembly by turning it in a counterclockwise direction, using tool number **35-2968**.
5. Remove the suspension springs to prevent damage to the tub braces and unbolt the tub braces from the tub support.
6. To remove, lift up on the bearing and seal housing with tub support attached.
7. To disassemble tub support from housing, remove mounting screws from underside.

## TUB SEAL

There are 2 Tub Seal designs, the original Face Seal and the new Triple Lip Seal introduced at series 17.

### Face Seal

The tub Face Seal consists of the seal face and seal body.

**NOTE: All parts of the seal must be replaced if either of the sealing surfaces are damaged.**

The seal face fits into a recess in the underside of the basket hub assembly. Also, the seal body installs in the cavity on the top side of the bearing and seal housing. The spin bearing is located in a cavity on the underside of the bearing and seal housing.

Each of the two (2) sealing parts, the seal face and the seal body, have sealing faces which are brought into contact with one another when the basket hub assembly is threaded down on the drive tube. The springs in the seal body exert pressure to keep the sealing faces in contact.

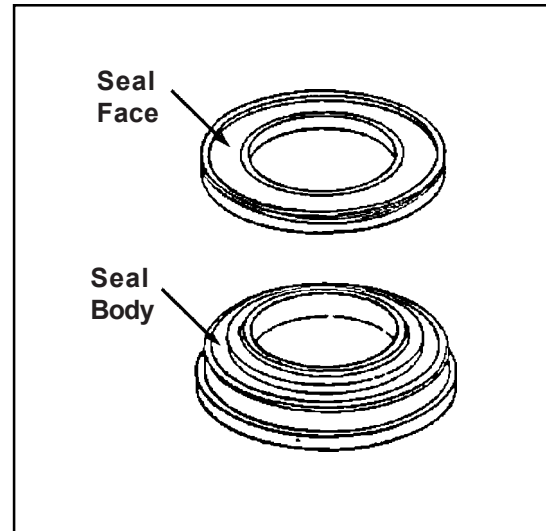

### Triple Lip Seal

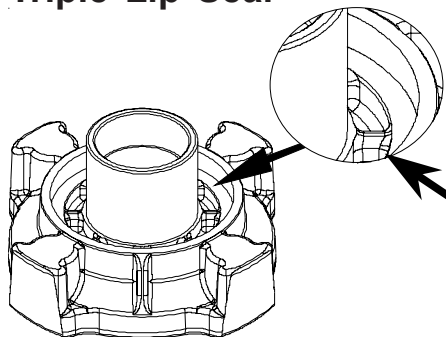

Triple Lip Tub Seal Assembly used with the 21001867 Hi-Torque Transmission Assembly.

**NOTE:** Sealing surface are on the O.D. of the aluminum spinner hub with no seal in the hub cavity.

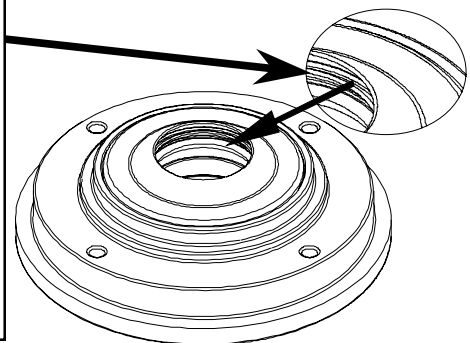

**NOTE:** The Triple Lip Seal and Bearing is **only** used with the High Torque Dual Drive transmission. The 21001867 High Torque service transmission will include a Triple Lip Seal and Bearing for proper matching of parts. The High Torque transmission will have An "HT" next to the date code for field identification purposes. Do not use 21001868 Seal kit on older transmissions not designed to operate at higher torque levels. Always refer to Parts Pro or Microfiche for proper parts ordering. The 21001868 Triple Lip Seal kit will include a sticker to be placed on the Outer Tub of the washer to identify the washer has been modified with a High Torque Transmission and Triple Lip Seal kit.

---

## TUB SEAL REPLACEMENT:

Should the tub seal begin to leak or develop excess seal drag, it must be replaced. The service replacement seal includes all the parts necessary to replace the entire seal. Be sure to replace all parts of the seal even if only one part is found to be damaged.

**NOTE: If the tub seal is being replaced because it has begun to leak, the spin bearing is probably defective also and should be replaced. To replace the spin bearing, the bearing and seal housing must be removed as previously described. This also allows access to the tub seal for removal and replacement (refer to steps 2 and 3 below when installing).**

**Removal and replacement of the tub seal can ONLY be accomplished as follows:**

1. Follow steps 1 through 3 for the face seal

NOTE: For Triple Lip Seal special instruction, see next column

## FACE SEAL

2. Before installing the new seal, coat the mounting recess of the housings with silicone grease (part number **203959**). This will allow the seal body and seal face to slip into position.

**NOTE: MAKE SURE NO GREASE COMES IN CONTACT WITH THE MATING SURFACES OF THE SEAL.**

3. Make sure both seal mating surfaces are free of foreign matter, then clean both surfaces with an alcohol saturated cloth.

**NOTE: Do not use any agent other than alcohol to clean the mating surface. Do not use any lubricant other than Silicone Grease, part number 203959.**

## TRIPLE LIP SEAL

1. Apply center seal grease (056016) to Seal Nut and Triple Lip Seal before installing.

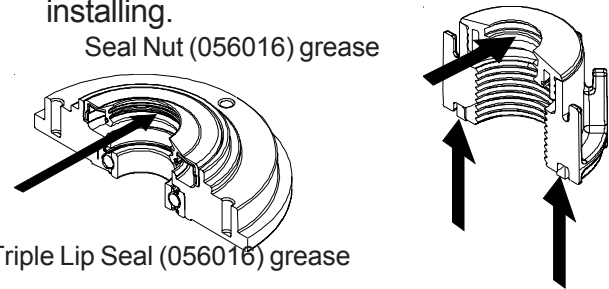

---

## SPIN BEARING

The spin bearing is installed in a cavity on the underside of the bearing and seal housing. It is also press fitted and bottoms out on the cavity shoulder. It is further secured in place by the inner diameter of the tub support.

## SPIN BEARING REPLACEMENT:

1. **Disconnect the unit from the power source.**
2. Remove the bearing and seal housing and the tub support as previously described.
3. Remove the seal body from the housing cavity.
4. Press the spin bearing out of the cavity from the opposite side of the housing.
5. When installing the replacement bearing into the housing cavity, be sure to press against the outer race of the bearing to avoid damage to the bearing shield and causing premature failure.

---

## DRIVE PULLEY AND CAMS

The drive pulley and cam is located below the brake assembly on the drive shaft.

Models are equipped with a plastic drive pulley which has the upper cam molded onto the bottom of the hub. The purpose of the pulley and cam arrangement is to drive the clutch assembly during the agitate and spin cycle, and to disengage the brake assembly during the spin cycle.

The drive pulley slips over the drive shaft and rests against a series of washers, a thrust bearing, and a large washer type spacer. The spacer locates against the bottom of the brake rotor and lining assembly. **(See the illustration on page 6-6.)**

The lower cam slips over the end of the drive shaft where splines formed in the cam engage with mating splines on the drive shaft end. This imparts a direct drive from the cam to the drive shaft. A shoulder molded on the bottom of the pulley hub engages "dogs" formed on the sides of the lower cam, and will drive it and the drive shaft in either direction.

A washer and retaining ring secure the pulley and cam on the drive shaft. A plastic dust cap snaps to the underside of the pulley to keep the cam surfaces clean.

---

## OPERATION:

When the drive pulley rotates **CLOCKWISE**, the upper and lower cams are designed to nest together which allows the drive pulley to remain in position on the drive shaft. The break remains engaged and the drive pulley will turn the lower cam and drive the shaft to cause the transmission **to agitate**.

When the drive pulley rotates **COUNTER-CLOCKWISE**, the upper cam and pulley ride up the lower cam approximately 3/16 of an inch before the driving shoulders on the pulley hub engage the "dogs" on the lower cam.

This causes the top of the pulley hub to push against the spacer which compresses the brake spring and lifts the brake rotor and lining assembly off the brake stator. The brake is disengaged and the pulley will turn the lower cam and drive shaft to cause the transmission **to spin**.

# Original Thrust Washer Design

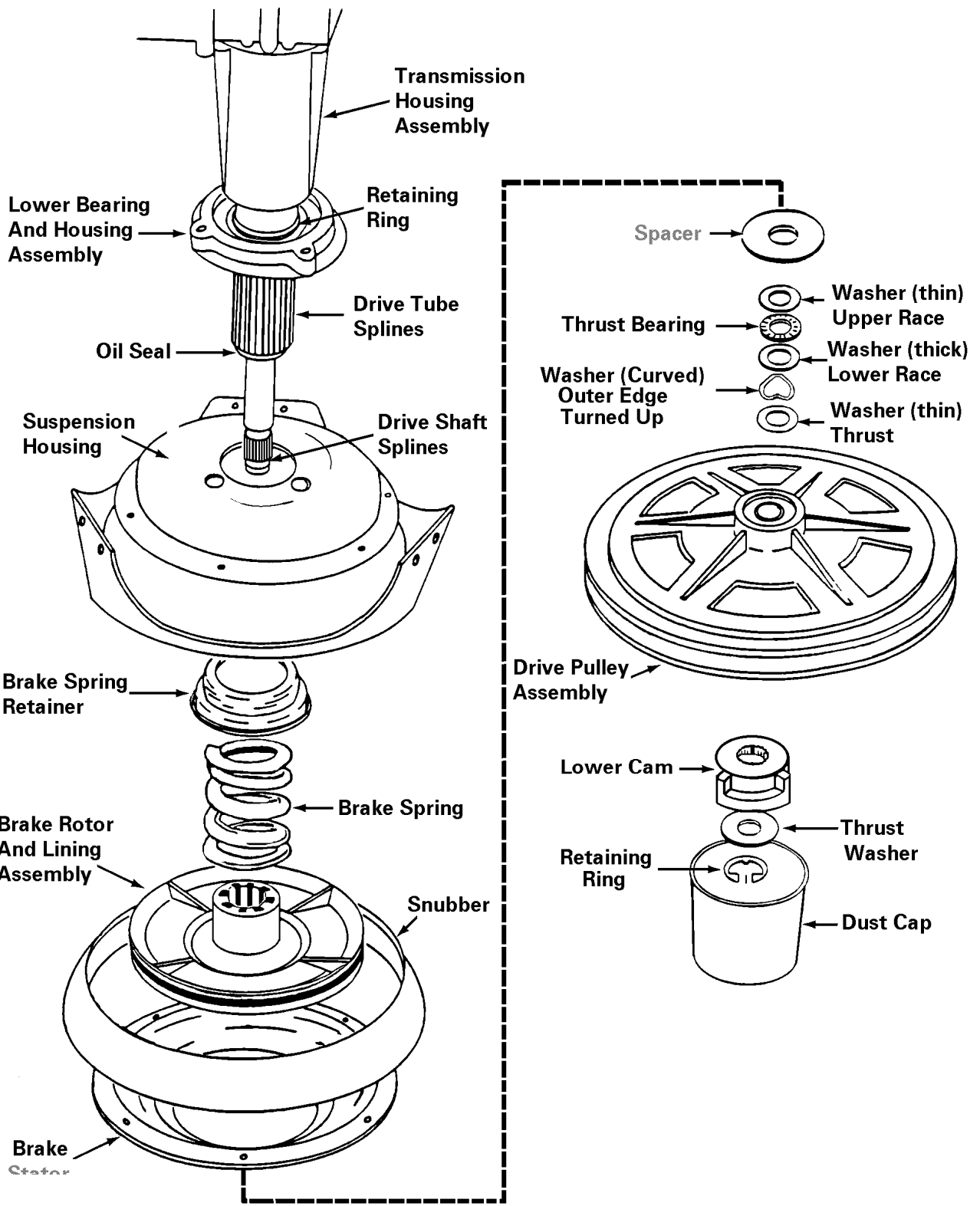



## REMOVAL:

1. **Disconnect the unit from the power source.**
2. Tip the unit over and remove the drive belt.
3. Remove the dust cap from the under side of pulley.
4. Remove retaining ring and washer from end of drive shaft.
5. Firmly pull lower cam off the drive shaft splines, then slide the other parts off the shaft. This will also allow access to the brake assembly for removal.

## REASSEMBLY:

After reassembling the components on the drive shaft, it will probably be necessary to pull down on the shaft to take the end play out of it before the thrust washer and retaining ring can be reinstalled.

**NOTE:** *Each time the cams are reassembled on the drive shaft, the point in the cam rise where the brake disengages the stator should be checked and adjusted as necessary.*

Reference marks have been molded around the bottom outer edge of the lower cam as an aid in checking the point of brake disengagement (*see following figure*). Each mark, from right to left, represents approximately .010 of an inch cam rise.

### To Check Brake Disengagement:

1. Manually rotate the drive pulley in a slow counterclockwise direction until

the brake starts to release and the transmission begins to turn.  
(*See following figure*).

2. Counting the reference marks on the lower cam from right to left, the pulley hub shoulder should be positioned between reference marks 9 and 3, with 6 being the median.  
(*Shown in the following figure*).

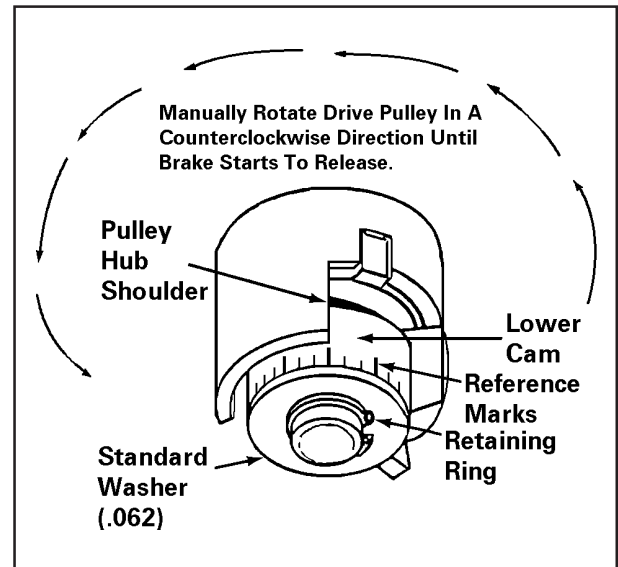

If the position of the pulley hub shoulder ***is not*** within these parameters and the brake has started disengaging, ***adjustment is required***.

### To Adjust Brake Disengagement:

1. If the position of the pulley hub shoulder is ***less than 3 reference marks***, remove the standard (.062 thickness) thrust washer and replace it with a thinner (.032 thickness) thrust washer (part number **35-2132**). Recheck disengagement.
2. If the position of the pulley hub shoulder is ***more than 9 reference marks***, add a **35-2132** thrust washer (.032) to the standard thrust washer and recheck disengagement.

---

## BRAKE ASSEMBLY

The brake assembly is located inside the domed area of the suspension housing and consists of the following components: brake spring retainer, brake spring, rotor and lining assembly, and the brake stator.

The brake assembly, as well as the snubber, is held in position by the brake stator which is secured to the underside of the suspension housing by six (6) mounting screws.

Spring pressure forces the rotor and lining assembly down on the brake stator and prevents the transmission from turning during agitation.

As stated previously, the drive pulley and cams provide a cam action which raises the drive pulley during the counterclockwise (spin) direction of the motor. When the drive pulley hub travels upward, it compresses the brake spring and moves the rotor and lining assembly up the drive tube disengaging it from the stator. The transmission is now free to spin.

Splines in the brake rotor hub mesh with splines on the drive tube end to provide positive vertical movement for the rotor and lining assembly. The splines are greased for ease of movement.

### CAUTION

**The brake assembly has a compressive spring force of approximately 200 pounds. See the following instructions for disassembly.**

### DISASSEMBLY:

1. **Disconnect the unit from the power source.**
2. Remove the drive pulley and cam components as previously described.
3. Using brake removal tool number **35-2442**, proceed as follows:
  - Pull out and remove "U" retainer from tool.
  - Slip the splined end of the drive shaft into hole located in the tool inner plunger.
  - Looking at the side of the tool, align slots on tool barrel and holes in tool plunger between splines and chamfered shoulder of shaft.
  - Slip "U" retainer through tool slots and holes capturing the drive shaft behind the chamfered shoulder.

**NOTE: Be sure "U" retainer is completely through both sides of tool.**

  - Tighten tool nut to compress brake spring **until transmission turns freely.**
  - Remove the six (6) screws which secure the brake stator and snubber to the underside of the suspension housing.
  - Loosen tool nut **until the brake spring reaches its free length.**
  - Remove "U" retainer from tool and remove tool from drive shaft.
  - Remove brake components.

## Reinstalling the Brake:

1. Apply silicone grease (part number **203959**) to the splines of the drive tube and rotor, if needed.

**NOTE:** *This is a dry operating brake assembly. Make sure no oil or grease comes in contact with the mating surfaces of the brake lining and/or brake stator. Clean both surfaces with an alcohol saturated cloth before reassembly.*

2. Compress the brake spring until the stator and snubber fit firmly against the suspension housing before affixing the mounting screws.
3. Follow the drive pulley and cam reassembly procedure as detailed previously.

---

## New Encapsulated Thrust Bearing Design

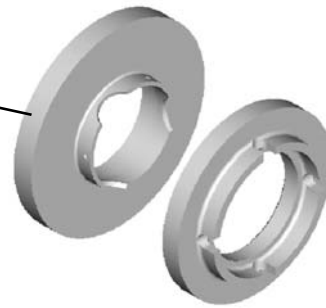

Encapsulated Thrust Bearing and Spacer

When installing the Encapsulated Thrust Bearing, verify the brake releases at the proper time. The brake should release between the minimum and maximum marks as shown. One of the two spacers provided in the kit may be needed to correct when the brake releases.

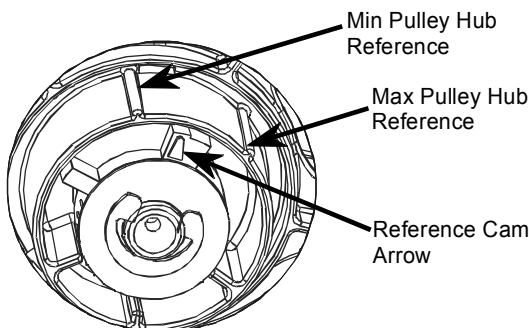

### **Determine Brake Rotor Condition**

Watch the spacer on the Encapsulated Thrust Bearing. If the spacer rotates with the pulley, the brake is functioning properly. If the spacer stays stationary while rotating the pulley to release the brake, the brake rotor must be replaced.

After reassembling the washer, fill the tub with water and select a spin to drain the tub. When the cycle is finished, verify the adjustment of the brake, and verify the spacer on the thrust bearing rotates with the pulley.

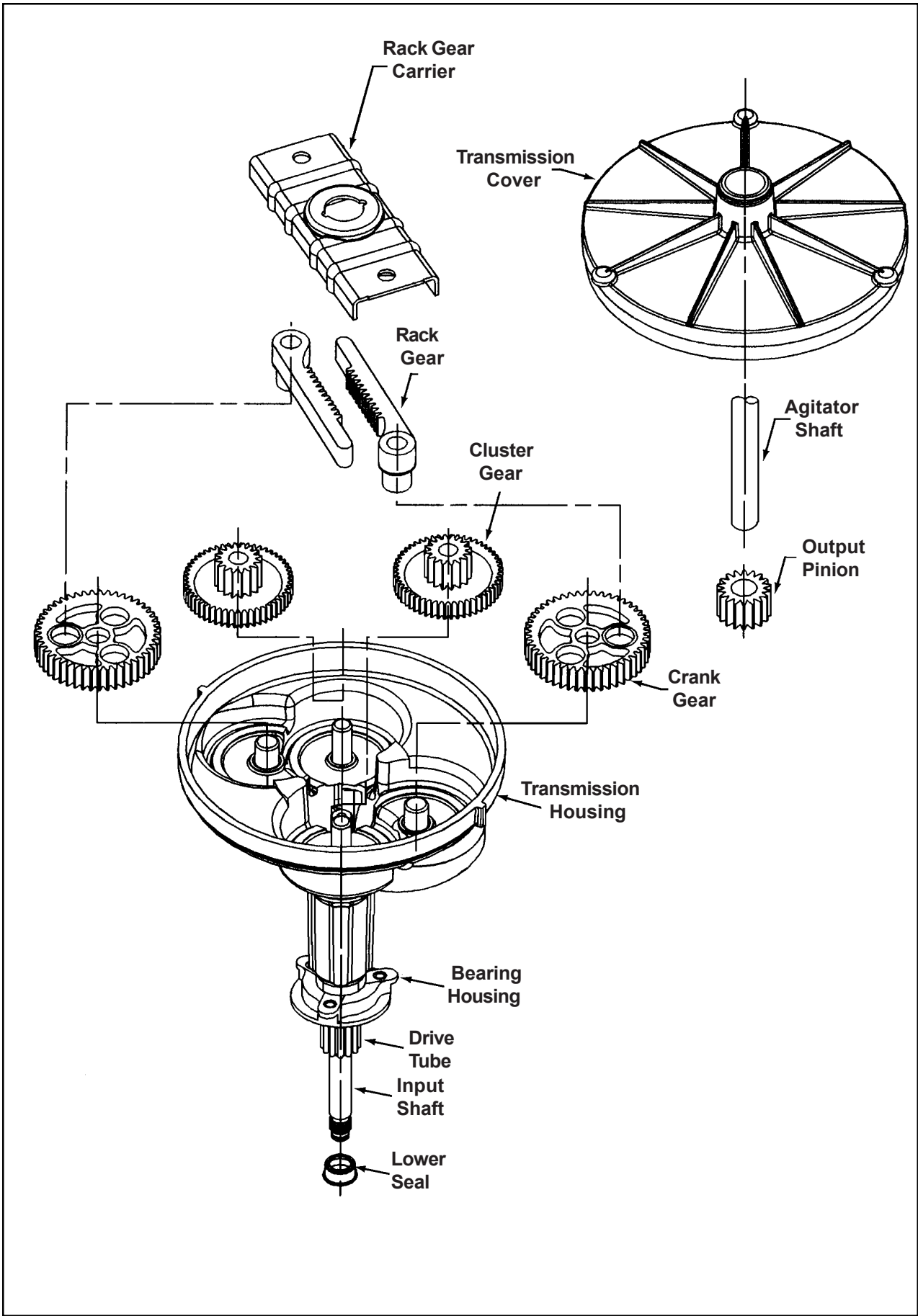

---

## TRANSMISSION HOUSING ASSEMBLY

The die-cast aluminum transmission housing has four studs pressed into its upper region. The studs provide mounting for the two crank and two cluster gears. The top cover is threaded into the lower housing. A sealant is used on the threads as a gasket material. A steel drive tube with a splined end is pressed into the bottom of the transmission housing. A sleeve bearing is installed in the lower I. D. of the drive tube. Another bearing is pressed into the lower housing above the drive tube. These bearings provide a path for the drive shaft to ride in. An oil seal is installed in the bottom of the drive tube. The oil seal can be replaced as a separate part.

---

### Oil Seal Replacement:

The oil seal is located in the spline end of the drive tube. The seal can be replaced without removing or disassembling the transmission, as outlined below:

1. **Disconnect the unit from the power source.**
2. Remove the brake assembly to access the seal.
3. Use a thin, flat bladed screwdriver to carefully pry the old seal out.
4. Place the drive washer (tool number **14242**) and the new seal over the seal protector.

5. Remove the cone-shaped end from the seal protector tool and slide the tool, drive washer, and new seal over the drive shaft up to the seal cavity.
6. Slide the transmission seal driver (tool number **14242**) over the drive shaft until it makes contact with the drive washer. Use the impact sleeve of the tool to "tap" the seal into the end of the drive tube.

---

## LOWER BEARING ASSEMBLY

The lower bearing assembly consists of a ball type bearing which has been installed in an aluminum die-cast housing. The transmission assembly must be removed from the washer cabinet before the lower bearing assembly can be replaced.

The lower bearing assembly provides lateral support for the drive tube and shaft against the tension of the drive belt. The top of the suspension housing is attached to the underside of the lower bearing assembly.

### REPLACEMENT:

#### IMPORTANT

**Because the lower bearing assembly has been pressed onto the drive tube under approximately 1,000 pounds of pressure, a puller must be used to remove it. However, the puller forcing screw must not be used on the end of the drive shaft or the clutch assembly could be damaged. Instead, a simple pipe and cap assembly can be made to slip over the drive shaft, with end clearance, and rest against the end of the drive tube.**

The puller forcing screw is used on the end of the pipe cap which directs the forward thrust of the puller to the bottom of the drive tube.

#### REMOVAL:

1. **Disconnect the unit from the power source.**
2. Remove the transmission from the washer cabinet.
3. Remove the cams, drive pulley, and brake assembly.
4. Remove the three (3) screws which secure the suspension housing to the lower bearing assembly.

5. Slip the pipe and cap assembly over the drive shaft and up against the drive tube.
6. Using a puller with at least a 3 1/2 inch spread and sufficient reach to encompass the pipe and cap assembly, remove the lower bearing assembly.

**NOTE:** *When installing the new lower bearing assembly, be sure to drive against the inner race only to avoid damaging the bearing shield which could cause premature failure.*

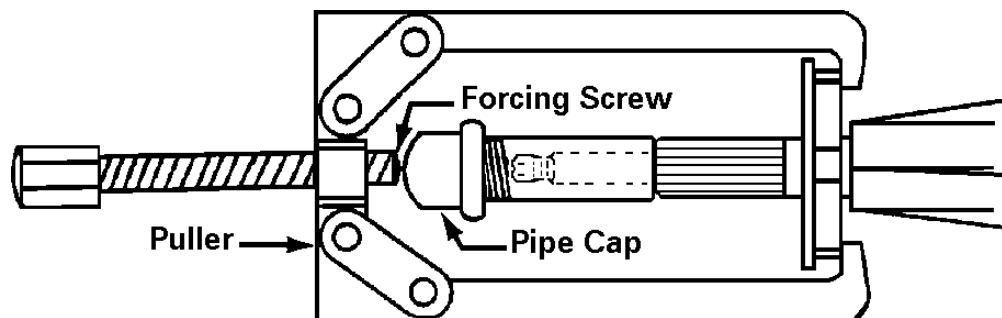
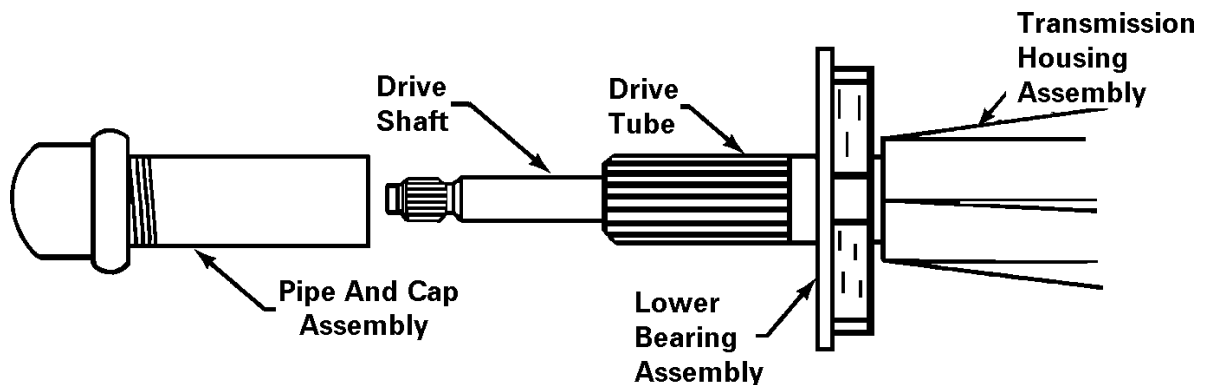

---

## DIAGNOSING TRANSMISSION PROBLEMS

Listed below are most of the service complaints which would normally be caused by a malfunctioning component of the transmission assembly.

---

### Oil Leaks

Oil leaks can be caused by faulty seals, gaskets, or a loose fitting stud.

---

### Slow Spin Speed

Slow spin speed can be caused by a binding tub seal and/or bearing, brake rotor assembly not disengaging properly, a slipping clutch spring, or an off balance clothes load. The test that follows can be used to isolate the problem.

---

### TORQUE TESTING:

A quick test of the efficiency of the spin operation components can be made by placing a 3 1/2 pound weight, such as a bag of sand, in the washer basket and starting the machine in the spin cycle. If the basket appears to reach full spin with the weight, the machine components are performing as intended. If the basket does not attain full spin speed, the torque test procedures as outlined in the following paragraphs should be performed to determine the problem.

The torque available to drive the spin basket is determined by the amount of drag or resistance presented by the tub seal and spin bearing, deducted from the input torque imparted to the transmission housing assembly by the clutch assembly.

***The Following Torque Tests Will Allow a Problem in the Spin Drive Train to be Pinpointed:***

***NOTE: Before starting these tests, the washer should be operated in the agitation cycle with hot water for about two (2) minutes, and then for two (2) minutes in a spin cycle. This warms up the transmission oil and the spin drive train components.***

---

### Available Torque

Place a 1/2 inch socket and torque wrench on the agitator retaining bolt.

Depress the safety spin switch to allow the washer to operate in the spin cycle, then while reading the torque allow the wrench to turn slowly (about 6 R.P.M.) through a complete 360 degree cycle. The reading should be between 18 and 25 inch pounds throughout the complete 360 degree rotation of the wrench.

If the torque readings are within these limits, the washer is performing properly and any slow spin complaints can be assumed to have been the result of off-balance loads.

If the torque reading exceeds 25 inch pounds, the input torque outlined later should be checked to determine the cause. Probable causes are that the drive shaft is binding in the transmission housing (drive tube) sleeve bearings, or that the clutch spring is binding on the drive shaft hub.

If the available torque reading is less than 20 pounds, follow the procedure for testing the drag torque.

---

### Drag Torque

Position the washer so the drive pulley can be accessed, and remove the drive belt. While holding the transmission to keep it from turning, manually rotate the drive pulley counterclockwise **until the brake stays disengaged**. Make certain the drive pulley hub shoulder has rotated fully against the cams in the spin driving position to ensure the complete disengagement of the brake. Release the transmission so it is free to turn.

Place a 1/2 inch socket and torque wrench on the agitator retaining bolt.

Slowly rotate the wrench 360 degrees at approximately 6 R.P.M. and read the torque. If the torque reading is over 4 inch pounds, remove the brake stator (as detailed earlier in this section) and re-check the drag torque.

If the torque reading is now under 4 inch pounds, the brake is binding and should be repaired.

If the reading is still over 4 inch pounds, the tub seal and/or spin bearing is binding and should be replaced.

If the **available torque** reading is below 18 inch pounds and the **drag torque** reading is not over 4 inch pounds, follow the procedure for checking the clutch assembly as to its input torque.

---

### Input Torque

**NOTE: *It will be observed that the readings used to check the input torque are slightly lower than the readings used to check the available torque. The reason for this is when the brake is disengaged, as in checking the available torque, the compressed brake spring exerts a downward force on the bottom of the clutch hub and thrust washers. This keeps the clutch spring from slipping quite as readily as in checking the input torque where the brake is engaged and the downward force on the clutch hub is minimized.***

To check the input torque, remove the drive pulley and position the washer so the scale on the torque wrench can be read when it is placed on the input (drive) shaft. Attach the torque wrench adapter **firmly** to the shaft, place the wrench in the adapter and slowly rotate the wrench in a counterclockwise direction. A properly operating clutch assembly will have a torque reading between 17 and 20 inch pounds.

If the input torque is less than 17 inch pounds, the clutch assembly is defective and must be repaired or replaced.

If the input torque exceeds 20 inch pounds, remove the clutch assembly from the transmission. Secure the drive



pinion in a vise using two (2) small blocks of wood to prevent damage to the gear teeth, and repeat the input torque check.

If the torque reading is between 17 and 20 inch pounds, the drive shaft is binding in the sleeve bearings.

If the torque reading still exceeds 20 inch pounds, the clutch assembly is *defective* and must be repaired or replaced.

---

### TRANSMISSION REMOVAL:

The transmission assembly can be removed from the washer cabinet after removing the drive belt, spin basket, outer tub and the suspension springs.

**NOTE:** *Be sure to dust the base dome lightly with cornstarch before installing the transmission.*

### CAUTION

***Once the agitator has been removed, the center post slips off the shaft. Therefore, do not attempt to handle the drive train by the center post after the agitator has been removed. Instead, after removing the agitator and the agitator shaft "O" ring, slip the center post off the shaft and handle the drive train by the shaft.***

**NOTE:** *If the "O" ring is to be reused, be extremely careful not to damage it during the removal.*

Remove the center post, "O" ring and agitator once the drive train is back in place.

The transmission assembly, when removed as described, will have the related components assembled to it. These related components should be examined carefully before reinstalling.

### IMPORTANT

**When installing the transmission, it is necessary that the tub be located on the tub support a certain way if all the mounting holes are to be properly aligned. This should be done before attempting to mount the tub to the bearing and seal housing.**

To assist in correctly positioning the tub, a small indentation has been formed on the tub support just above one of the tub brace mounting areas. This is the left front tub brace.

When the tub is in proper position and ready to be mounted to the tub support, the large tub cover lock (on the side of the tub) should be located directly above the indentation and tub brace.  
**(See the illustration on page 6-14.)**

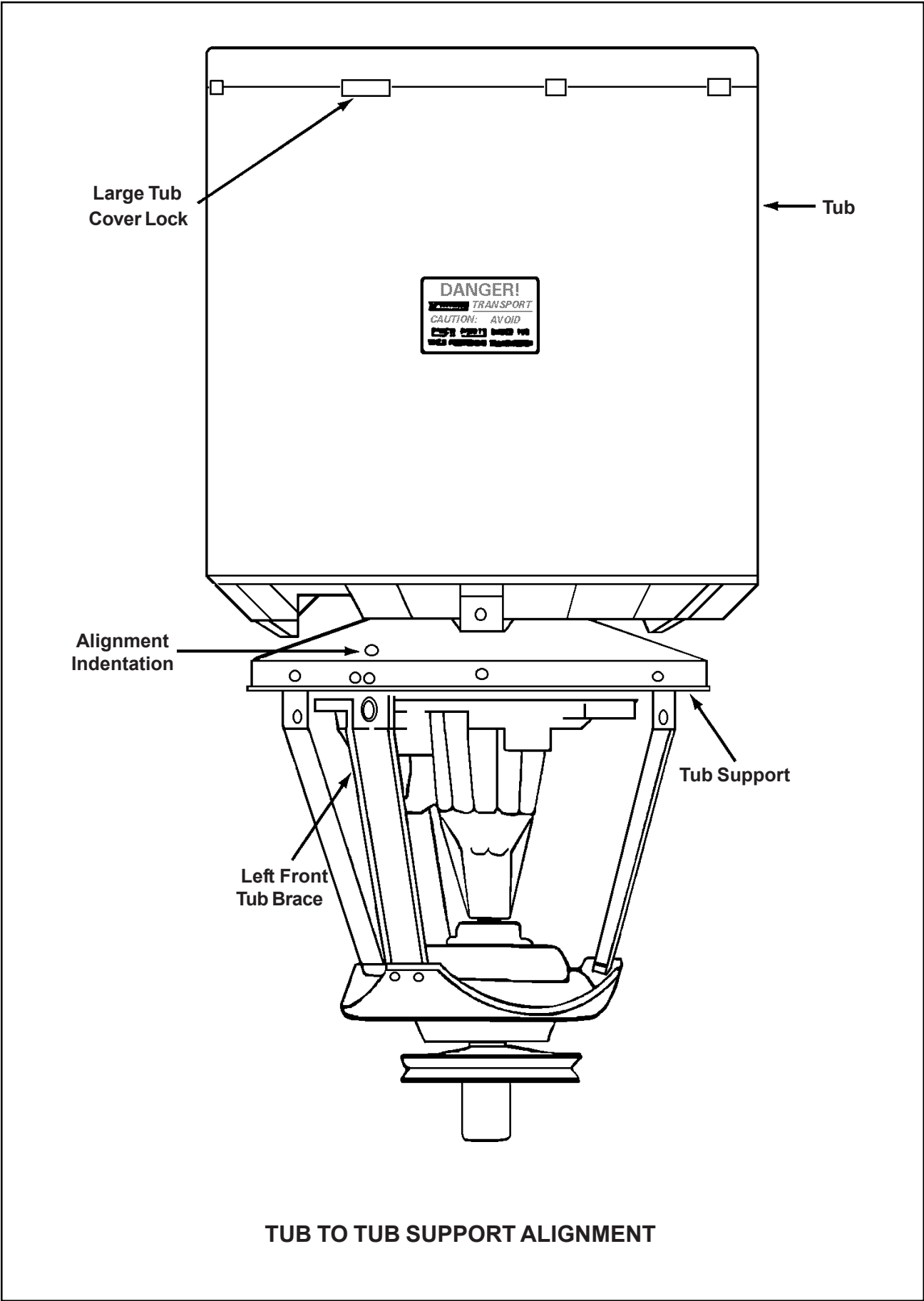

# SECTION 7. ELECTRICAL COMPONENTS AND TESTING

## TIMER

The timer is mounted to the control shield, located inside the control panel assembly. The timer shaft protrudes through the control panel and provides for the selection of the various machine cycles available.

The timer is an incremental advance, rotary type driven by a synchronous motor. The timer controls and sequences the numerous steps and functions involved in each machine cycle. It accomplishes this by providing power to the various electrical components through the opening and/or closing action of timer contacts.

A typical timer and plug connector are illustrated in the following figure. The timer has all the connecting points brought out to miniature spade terminals. These terminals are centralized and aligned on one side of the timer to form a terminal board.

The connecting wires from the wiring harness are terminated in a compatible connector which plugs into the timer terminal board.

Since space is notably limited on the timer terminal board, terminal identification is provided by a sticker attached to the side of the timer. When referring to the sticker for terminal identification, the external timer motor wires can be used for orientation.

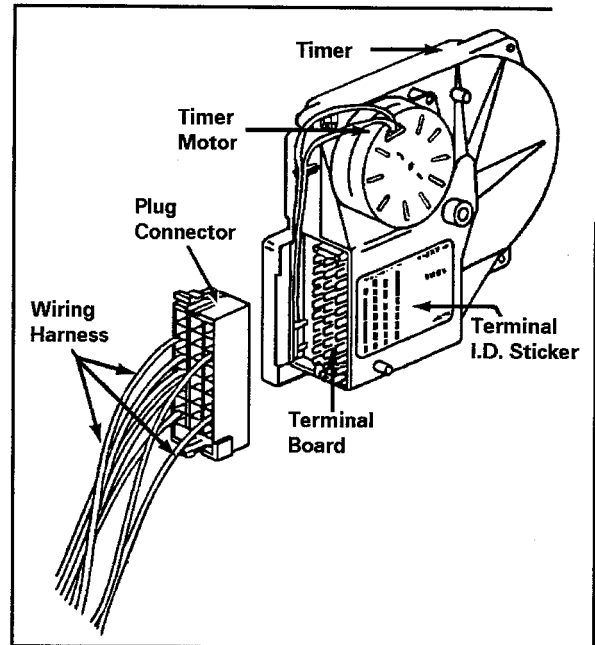

Another source for terminal identification is the schematic diagram which is supplied with each washer. The schematic diagram not only identifies the terminals, but also the plug connector terminals and their respective wire colors.

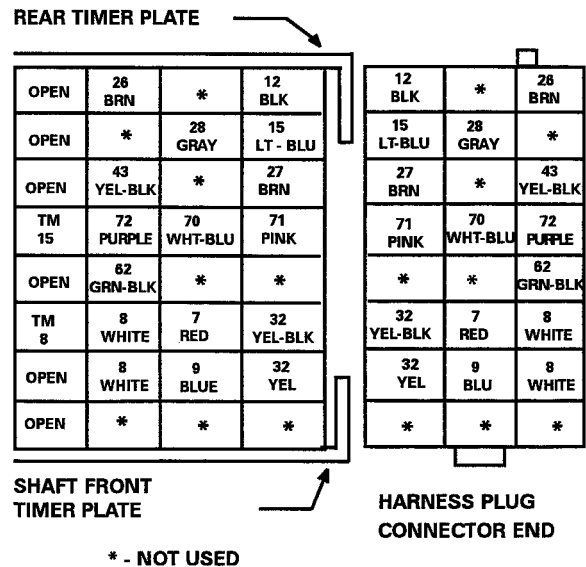

**REMOVAL:**

Timer removal procedures are detailed in Section 3 under *Control Panel Disassembly*.

**Timer Testing:**

The timer can be tested by using an ohmmeter and the *Timer Sequence Chart* as detailed following.

Listed down the side of the chart at the left, each contact in the timer is identified as being controlled by a particular cam. The function of each contact and its terminal designation is also indicated.

Across the bottom of the chart are the various machine cycles available for selection, and the timer increments at which the cycle begins, proceeds and ends. The increment, or degree division, indicates the travel of the timer through a cycle.

**TIMER SEQUENCE CHART**

The following chart depicts a typical *Timer Sequence Chart* which can be found on the schematic diagram. It denotes the internal timer contacts which are opened and/or closed by the timer cam switches at any interval during a machine cycle.

The heavy black lines to the right of the terminal column indicate a closed contact. If the contact is open, there is a break in the heavy black line.

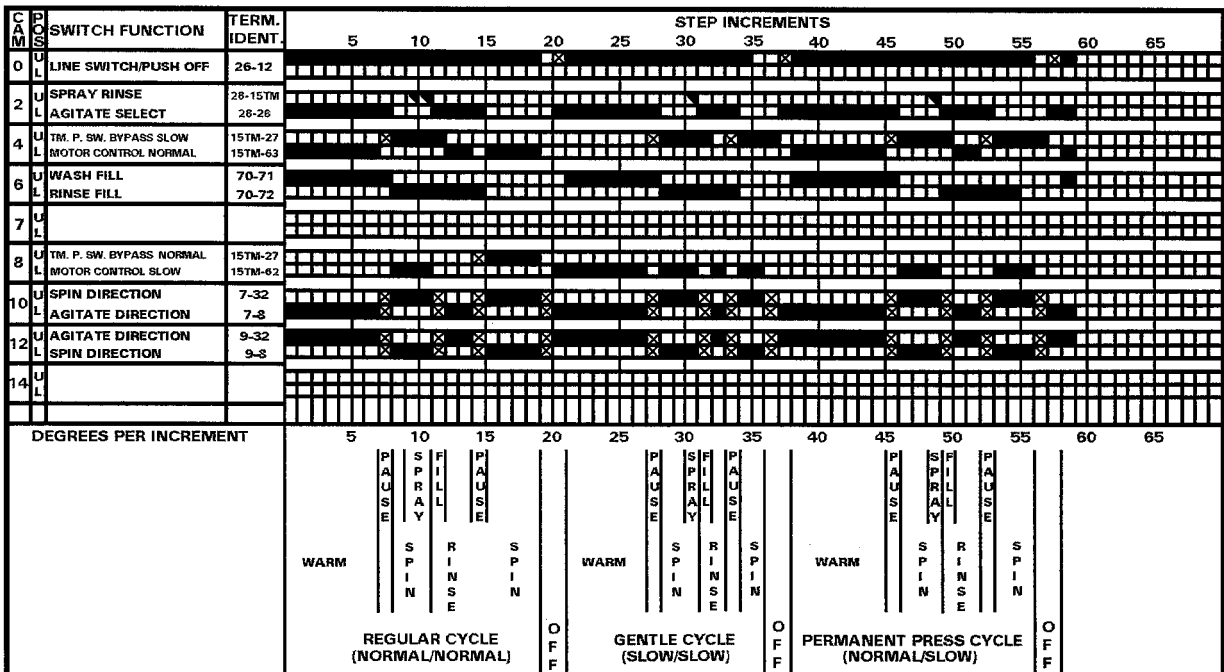

### EXAMPLE

Cam OU shows the switch arm closed, making contact between terminal 12 and 26 from increments 1 through 18. This circuit is the cam controlled ON/OFF switch in the timer and at increment 19 it opens, shutting the machine off.

### Using the Time Sequence Chart:

The sequence chart used in conjunction with an ohmmeter can be quite effective when attempting to verify or diagnose problems in the timer, wiring, or other electrical parts.

In order to establish exactly which electrical components should be operating during any given time throughout the various machine cycles, it is only necessary to determine what particular cycle and phase of the cycle you are interested in.

Once the cycle and phase have been ascertained, locate these along with the increment at the bottom of the **Timer Sequence Chart**. When the cycle, phase and increment are located, follow the increment from the bottom to the top of the chart noting which timer contacts are involved in the area of concern.

Once the timer contacts have been determined, the electrical circuits involved can be traced on the connection diagram by increment or by phase, if necessary.

A point to point continuity check can be made to isolate the trouble either in the timer, wiring harness, or other electrical components after the circuit has been traced.

## MOTOR

All washers are equipped with split phase reversible motors (*see the following figure*). The motor is 3/4 H.P., two speed. The motors have a four (4) pole and a six (6) pole winding and run at 1725 R.P.M. or 1149 R.P.M. respectively.

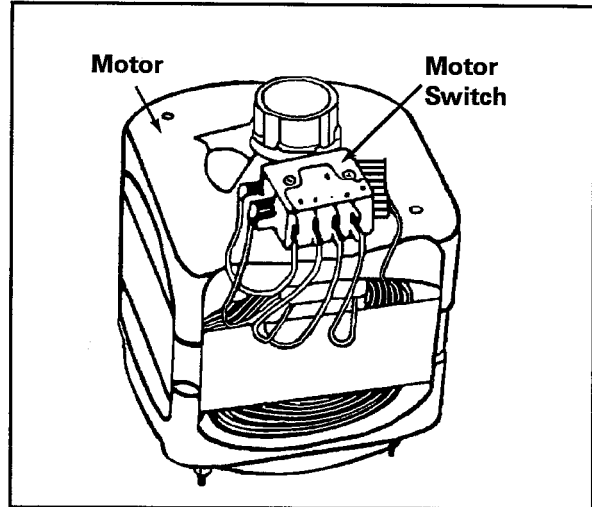

Each motor has an internal overload protector which will react to a temperature rise and/or excessive amperage draw. The overload protector is wired in series with the line, and all power to the machine is cut off if the protector switch opens. The protector switch is not field serviceable and if it fails, the motor must be replaced.

## MOTOR SWITCH

The externally mounted motor switch is a mechanically operated device used to control the power input when the motor starts.

On two speed motors it is necessary that the 4 pole winding, the normal speed winding, be in the circuit each time the motor starts even if the speed selector control is set for slow speed operation.

The wiring on two speed motors is arranged so that the motor switch directs power to the normal speed winding and the start winding to start the motor. When the motor reaches switching speed, the switches move opening the circuit to the start winding and at the same time transferring the power from the normal speed winding to the slow speed winding.

---

### **Motor and Switch Operation:**

The polarity of the magnetic field of the start winding, in relation to the magnetic field of the run winding, determines the direction of the rotation of the motor.

The timer is used to reverse the polarity of the start winding field and the operation of the motor start switch. *(See the line drawings as illustrated on page 7-5.)*

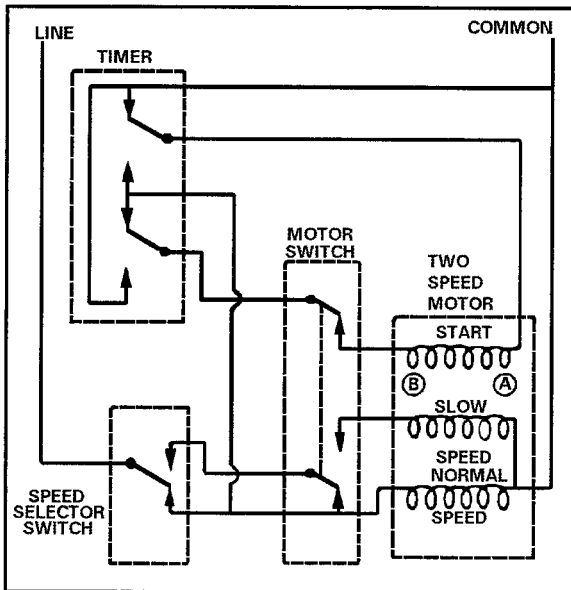

Side A of the start winding is connected to the common side, B is connected to the line through the motor switch. The speed selector switch is set for normal speed operation.

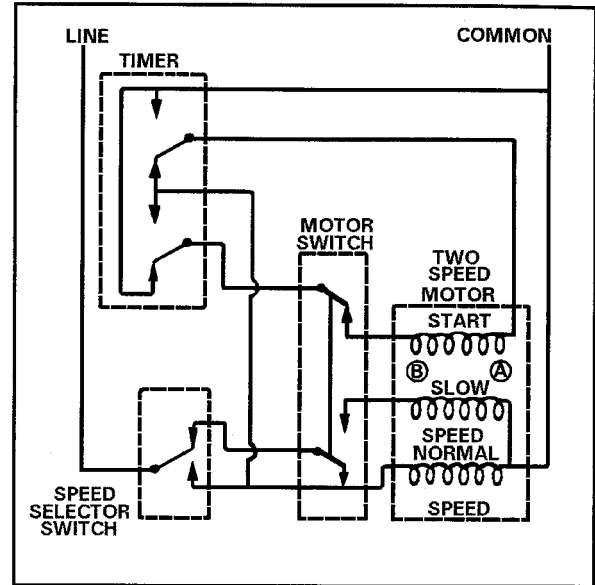

The timer selection has been changed, now side A of the start winding is connected to the line; side B is connected to the common side through the motor switch. The speed selector switch is set for slow speed operation. The motor switch is supplying power to the normal speed motor winding.

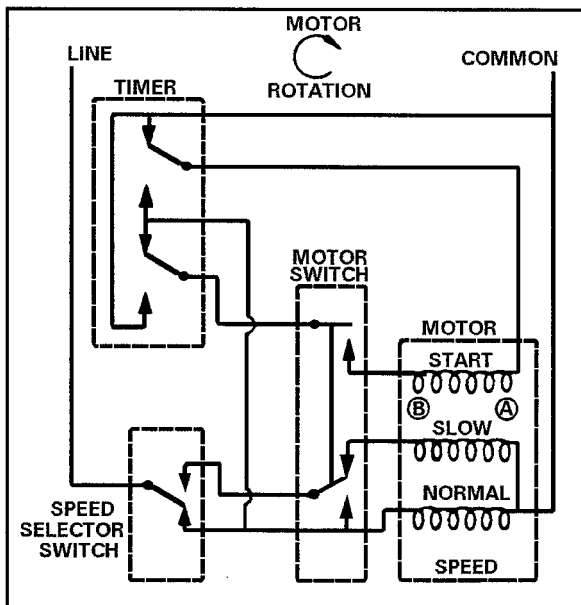

As the motor starts running, the motor switch moves opening the start winding circuit. The motor is running on the normal speed winding in the direction indicated.

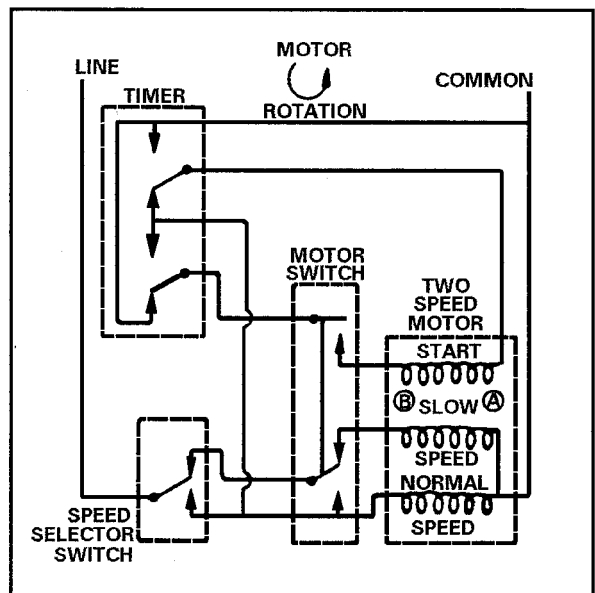

As the motor starts running, the motor switch moves opening the start winding and transferring the power from the normal speed winding to the slow speed winding. **The motor is running on the slow speed winding in the direction indicated.**

## MOTOR MOUNTING

The motor mount system consists of a motor and mounting plate assembly as shown in the following figure.

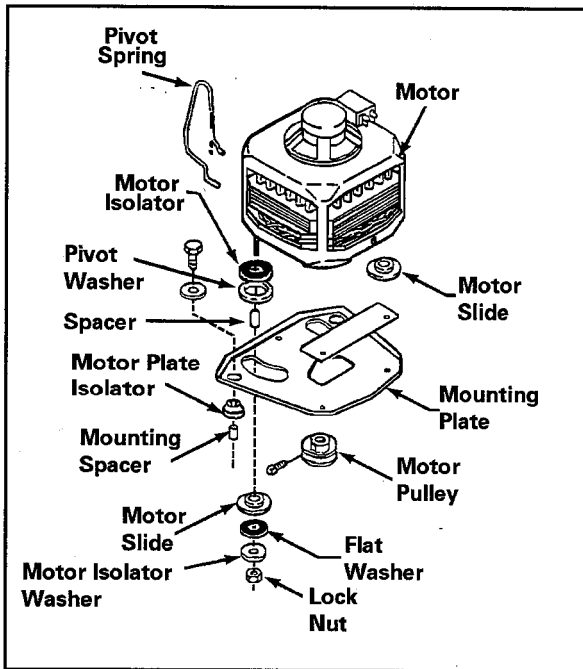

Assembled to the motor studs and secured by locknuts are rubber isolators and washers which sandwich nylon washers and slides through slots in the mounting plate. A nylon slide is attached to the motor bottom, and a pivot spring installs between the motor and mounting plate.

In operation, the nylon washers and slides ride in the slots in the mounting plate, and the slide rides the mounting plate. The motor is free to pivot in either direction and the pivot spring ensures proper belt tension on the motor pulley.

The mounting plate has rubber mounting cushions assembled to its rear corners, and the entire assembly is mounted to the washer base by two (2) large hex head screws.

## REMOVAL:

1. **Disconnect the unit from the power source.**
2. Tip washer and remove drive belt.
3. Remove the front panel.
4. Remove the two (2) large hex head screws which secure the motor and plate assembly to the base.
5. Remove the screw which secures the wiring clamp to the top of the motor. Disconnect the necessary wiring.
6. Remove the motor and plate assembly from the base.
7. To separate the motor and plate assembly, remove the motor pulley and the two (2) lock nuts which secure the components to the motor studs.

## IMPORTANT

**After reassembling the motor to the plate, be sure the nylon washers and slides move freely in the radiused slots. In cases where washers and slides do not move freely, the sides of the slots may be bent and require alignment. Check the slots for a rough surface or for oil and dirt which must be removed.**

**PERFORMA** washers are equipped with a nylon/glass filled motor pulley. This pulley is pressed onto the motor shaft where splines formed inside the pulley mesh with mating splines on the motor shaft. Small barbed fingers molded onto the front of the pulley hub, snap into a groove located at the end of the motor shaft.



**NOTE:** *The center hole of the motor plate is large enough to provide clearance for the pulley during motor and plate assembly.*

To eliminate the necessity of having to remove and replace the nylon/glass filled pulley when installing a replacement motor, the complete motor/pulley and plate assembly will be serviced (*as shown in the illustration*) ready to be mounted to the base. However, should a nylon/glass filled pulley become damaged in the field, a service replacement pulley is available. The pulley can be removed and replaced as follows:

**REMOVAL:** It is necessary to use a puller with at least a three (3) inch spread.

#### **INSTALLATION:**

1. Remove the shaft cover at the rear of the motor and "backup" the end of the motor shaft with a socket. This will prevent internal damage to the motor when tapping on the opposite end of the shaft during pulley installation.
2. With the hub fingers out, position the pulley over the motor shaft until the splines begin to mesh.
3. Place a 1/2 inch I.D. deep socket, pipe, etc., over the hub fingers and ***gently*** tap the pulley over the splines until it bottoms out on the shaft shoulder.

**NOTE:** *When the pulley has been properly positioned against the shaft shoulder, the hub fingers at the pulley front should be located in the shaft groove.*

4. Replace the shaft cover at the rear of the motor and reinstall.

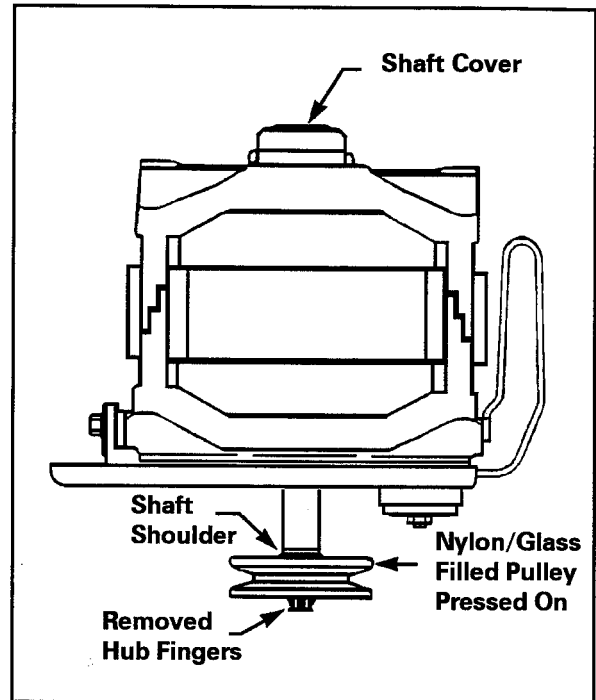

---

## **MOTOR CIRCUIT TESTING**

The motor overload protector, motor starting switch and the motor are the three components that should be tested if the motor assembly is suspected of being the cause of a service problem. The power cord should be unplugged and all wiring connections from the machine wiring harness to the motor starting switch should be disconnected before any testing is done to the motor.

---

### **Overload Protector**

The overload protector is built into the motor and is not serviceable. The contacts of the overload protector are normally closed and open in response to a temperature rise, an excessive amperage draw or a combination of both. The contacts reset automatically when they cool off. All automatic washers are

wired with the power line and if the contacts open, all power to the machine components is cut off.

If the overload protector opens repeatedly, check the following:

1. A binding condition in the motor or in the drive train.
2. Poor electrical connections causing a low voltage situation.
3. The motor overheats because of a restricted air flow. (The motor can get as hot as 200 degrees Fahrenheit and still be operating within design specifications.)

---

### Motor Switch

The motor switch has two sets of contacts which operate simultaneously. One set controls the start winding circuit. The second set feeds the normal speed cycle, and then switches the circuit to the slow speed winding.

To check the motor switch, connect a continuity tester between terminal 4 on the switch and the unmarked single terminal, toward the back of the switch, on the opposite side. The tester should indicate a closed circuit. When the switch button is depressed, the tester should indicate an open circuit. Now, check continuity between terminals 5 and 3. The tester should indicate a closed circuit in both tests. Next, connect the tester between terminal 5 and the unmarked single terminal next to terminal 3 and depress the button. The tester should indicate continuity.

If the machine will not run at all, use a continuity tester to check the overload

protector by reading from the P to P terminals at the motor switch.

---

### Motor

If the motor runs in one direction but will not reverse, the problem is in the timer or wiring harness, not in the motor. The same motor components are used when the motor runs in either direction; the only change is in the electrical circuitry feeding the start winding which is controlled by the timer and related wires.

A two conductor test cord which has two female spade connector terminals on each conductor is needed to test the motor operations (tool number **038183**).

To test a motor, connect the two spade connectors on one side of the cord to terminals 1 and 4 on the starting switch and the two connectors on the other side of the cord to the starting switch terminals 2 and 3.

To check the low speed operation, change the lead on terminal 3 to terminal 5. Be sure to test the motor in its normal vertical position. If the motor will not start, or if it starts but does not attain normal speed, check the operation of the external motor switch, replace the motor.

**NOTE: Normal resistance of the motor windings should be:**

HIGH SPEED	1.3 OHMS
LOW SPEED	2.3 OHMS
START	3.1 OHMS

---

### WATER MIXING VALVE

The water mixing valve is secured inside the right rear cabinet by two (2) mounting screws.

The mixing valve has two solenoids, one on the "**HOT**" water side and another on the "**COLD**" water side. These solenoids are energized through the timer and water temperature selector switch and will allow **COLD**, **HOT** or **WARM** (a mixture of **HOT** and **COLD**) water to enter the tub as directed.

### Testing Mixing Valve

The mixing valve can be accessed by raising the top. The valve can be tested using an ohmmeter and performing the following:

1. **Disconnect the unit from the power source.**
2. Remove all wiring from the solenoid(s) being tested.
3. Place the test leads across the terminals of the solenoid being tested. The meter should indicate continuity.

**NOTE:** *Normal resistance of each coil is approximately 860 ohms.*

4. Place one test lead on one terminal of the solenoid being tested, and place the other lead on a suitable ground. The meter **should not** indicate continuity.

---

### WATER LEVEL SWITCH

The water level switch is secured to the control shield, which is located inside the control panel assembly, by two (2) mounting screws.

The water level switch is operated by a column of air that becomes trapped in

the pressure switch hose. This hose is connected between the diaphragm section of the switch and air bell which is located on the lower portion of the tub. As water enters the tub, a small amount enters the pressure switch hose thereby trapping air in the hose. As the water level increases in the tub, this column of air becomes compressed and exerts pressure on the water level switch diaphragm. When the proper water level is reached the diaphragm actuates a single pole, double throw switch in the water level switch assembly.

The water level switch is quite sensitive and requires only about 0.6 P.S.I. to activate it at the maximum fill position. Therefore, it is most important that the hose connections to the switch diaphragm and air bell nipple be airtight, as the smallest air leak will cause erratic operation.

#### IMPORTANT

**The water level switch is adjusted and sealed at the manufacturing source and no adjustments should be made in the field.**

Whenever the hose is removed from the water level switch or the air bell nipple, **DO NOT** reconnect the hose until all water has been drained from the tub. To ensure proper operation of the water level switch, the hose **MUST NOT** have any water in it when reinstalled on the switch. When reconnecting the hose, be sure to slip it over the nipple(s) as far as possible and always replace the hose clamp(s).

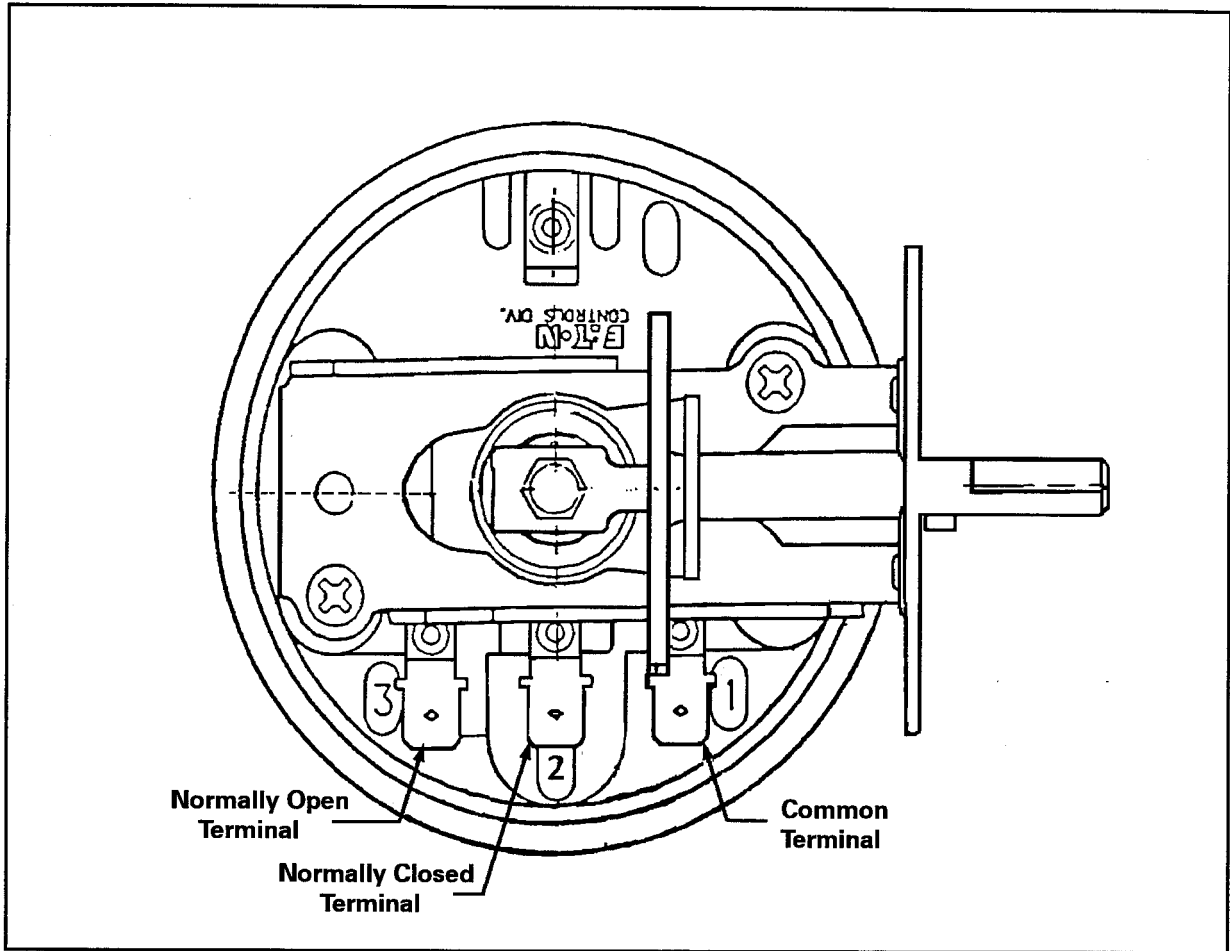

### Water Level Switch Operation

The circuitry of the machine is designed to put the switch in control of the water mixing valve or the timer motor and drive motor during various phases of the wash cycle.

During the fill cycle, the switch makes a circuit between its contacts 1 and 2 which energizes the mixing valve circuit(s). When the switch is activated, it opens the circuit between contacts 1 and 2 which shuts off the water, and closes a circuit between contacts 1 and 3 which energizes the timer motor and drive motor.

### Testing the Water Level Switch

The water level switch can be accessed as previously detailed in **Section 3** under **Control Panel Disassembly**. It can be tested using an ohmmeter and executing the following:

- When the tub is empty, ohmmeter leads placed across terminals 1-2 should indicate continuity.
- When the tub is filled as per the switch setting and corresponding water depth (*refer to Specifications Section under Water Level*), terminals 1-2 should be open and terminals 1-3 should indicate continuity.

## SELECTOR SWITCHES

On some models, motor speeds are controlled by the timer, but most models employ a separate switch or switches to control the speeds. The switches are a rotary type.

Selector switch charts indicating the contact alignment for the various positions of each switch used appear on the schematic diagram. These charts should be referred to for specific information on the model being serviced. Typical selector switch charts are shown in the following tables.

SPEED SELECTOR SWITCH		
N - N	64 - 66	67 - 65
S - N	64 - 65	67 - 66
S - S	64 - 65	67 - 65

WATER SELECTOR SWITCH	
POSITION	CIRCUIT
H - C	17 - 19
W - W	17 - 18 - 19 - 43
W - C	17 - 18 - 19
C - C	17 - 18

## Testing Selector Switches

The selector switch can be accessed as previously detailed in **Section 3** under **Control Panel Disassembly**. It can be tested using an ohmmeter and executing the following:

- Remove all switch wiring and perform continuity checks using the respective selector switch chart to indicate the proper continuity.

## SAFETY SPIN SWITCH

The safety spin switch assembly is constructed of thermoplastic. The safety spin switch, bracket, lever, and clip are mounted to the underside of the cabinet top. The switch is a single pole, throw type with normally open contacts.

A switch actuator is installed on the clothes door and protrudes down approximately 3/4" below the bottom edge of the door.

When the door is closed, the switch actuator passes through a slot in the cabinet top and contacts the switch lever. The switch lever is moved downward causing the switch to close its contacts.

**(See illustration below and on page 7-12.)**

### Clothes Door Open

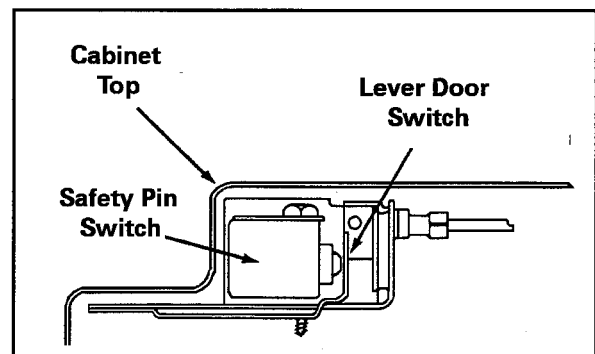

### Clothes Door Closed

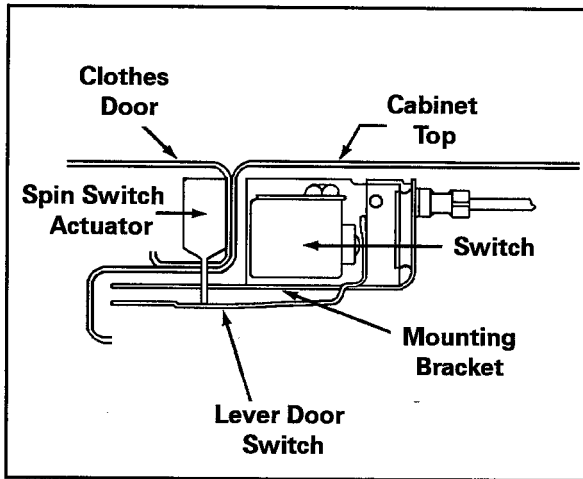

The safety spin switch controls the motor circuit during all spin cycles. When the clothes door is opened during a spin cycle, the motor is de-energized which allows the brake to engage, and brings the spinning basket to an immediate stop.

### Testing Safety Spin Switch

The safety spin switch can be accessed by raising the top and opening the clothes door. It can be tested by using an ohmmeter and performing the following:

1. **Disconnect the unit from the power source.**
2. Remove the two (2) screws securing the safety switch assembly to the underside of the top.

3. Remove switch wiring.
4. Place test leads across the terminals at each end of switch. The switch contacts should be open, and continuity **SHOULD NOT** be indicated.
5. Leave the test leads across the terminals and depress the switch button. The switch contacts should close and continuity **SHOULD** be indicated.

### SAFETY NOTE

*When the clothes door is opened, the safety spin switch should open the circuit before the door is raised 2 inches.*

*If the switch circuit is not interrupted before the door is raised 2 inches, it is imperative that the reason for the malfunction be found and corrected.*

**THE SAFETY SPIN SWITCH IS OBVIOUSLY A SAFETY FEATURE AND SHOULD NEVER BE DEFEATED OR BYPASSED.**

---

## SECTION 8. SCHEMATIC DIAGRAM

---

### SCHEMATIC DIAGRAM

A schematic diagram has been placed on the control panel of each unit. It can be accessed by removing the control panel shield located on the rear of the control panel.

The schematic diagram provides vital information needed to check a circuit and pinpoint a malfunctioning electrical component.

The schematic diagram contains the following:

- *Connection Diagram*
- *Ladder Wiring Diagram*

- *Cycle Sequence Chart*
- *Rear Board Connector Terminal Identification*
- *Motor Schematics*

A thorough understanding of the information available on the schematic diagram is a prerequisite for quick and accurate troubleshooting.

The *following illustrations, page 8-2 through 8-5*, depicts typical schematic diagrams for the washer.

# MODEL PAV100AWW WIRING DIAGRAM & ELECTRICAL SCHEMATIC

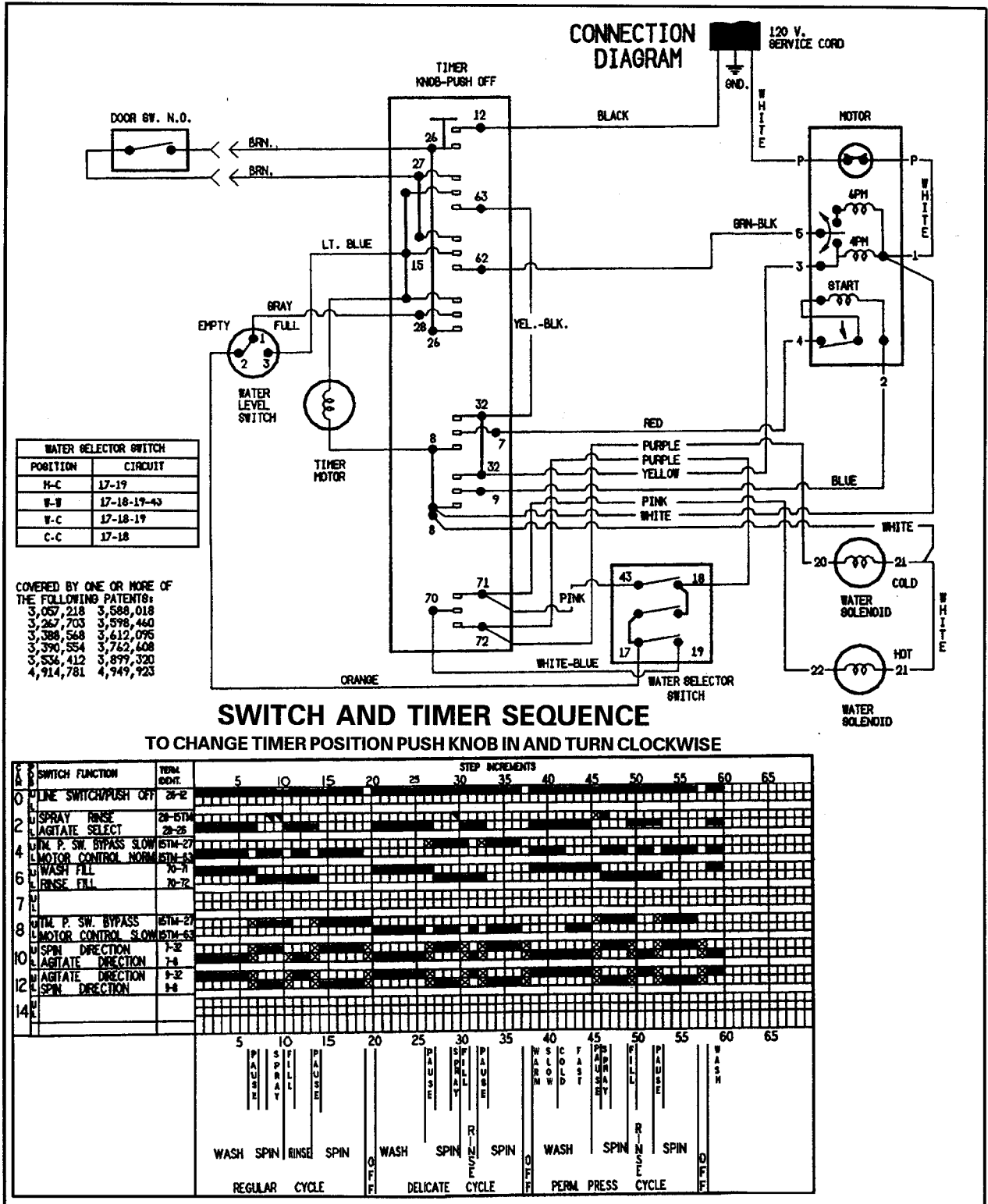



# MODEL PAV1000AWW WIRING DIAGRAM & ELECTRICAL SCHEMATIC CONT'D.

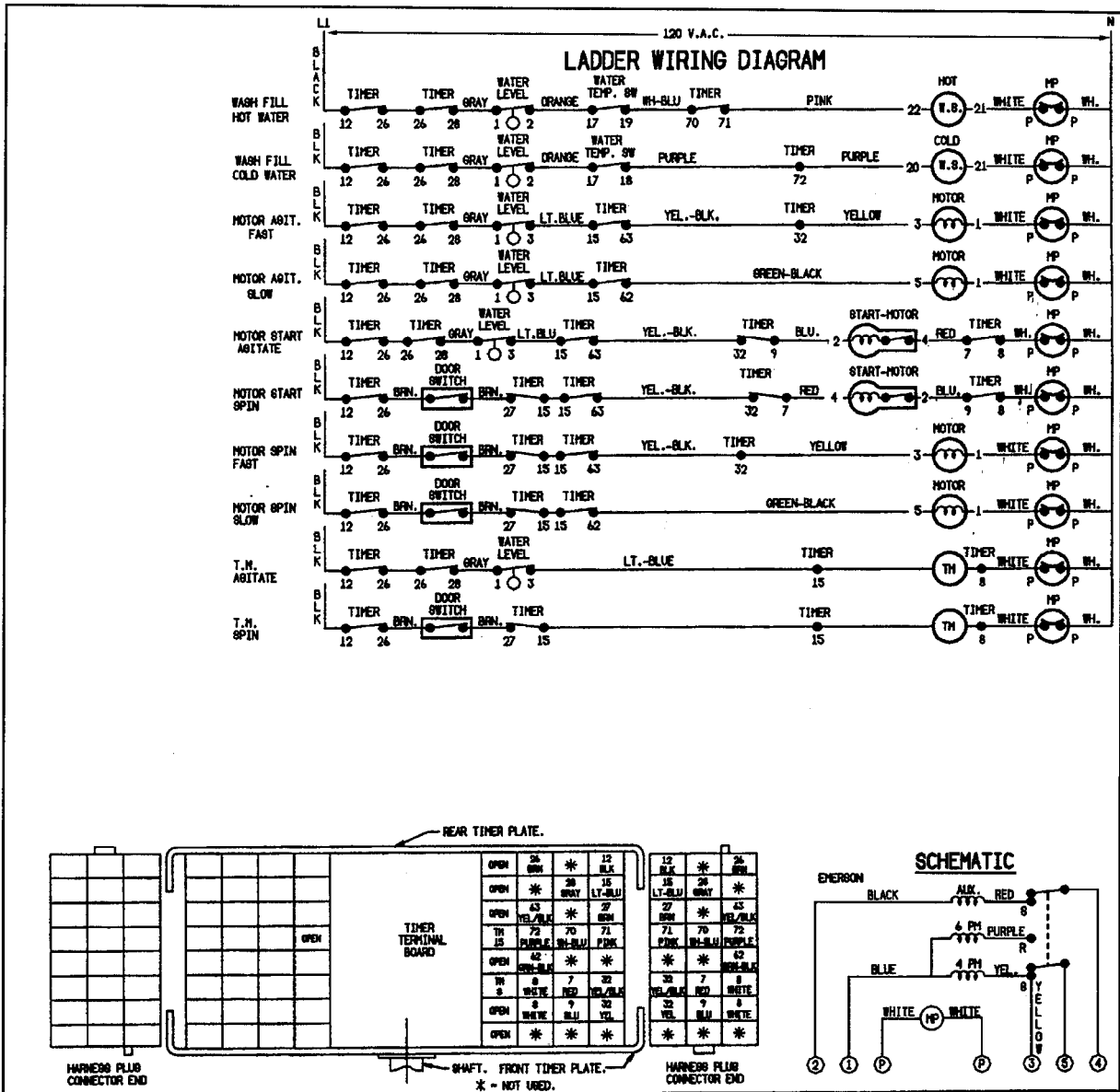

DISCONNECT POWER BEFORE SERVICING  
CAUTION: KEEP CLEAR OF SPINNING POWER UNIT

# MODEL PAV2000AWW WIRING DIAGRAM & ELECTRICAL SCHEMATIC

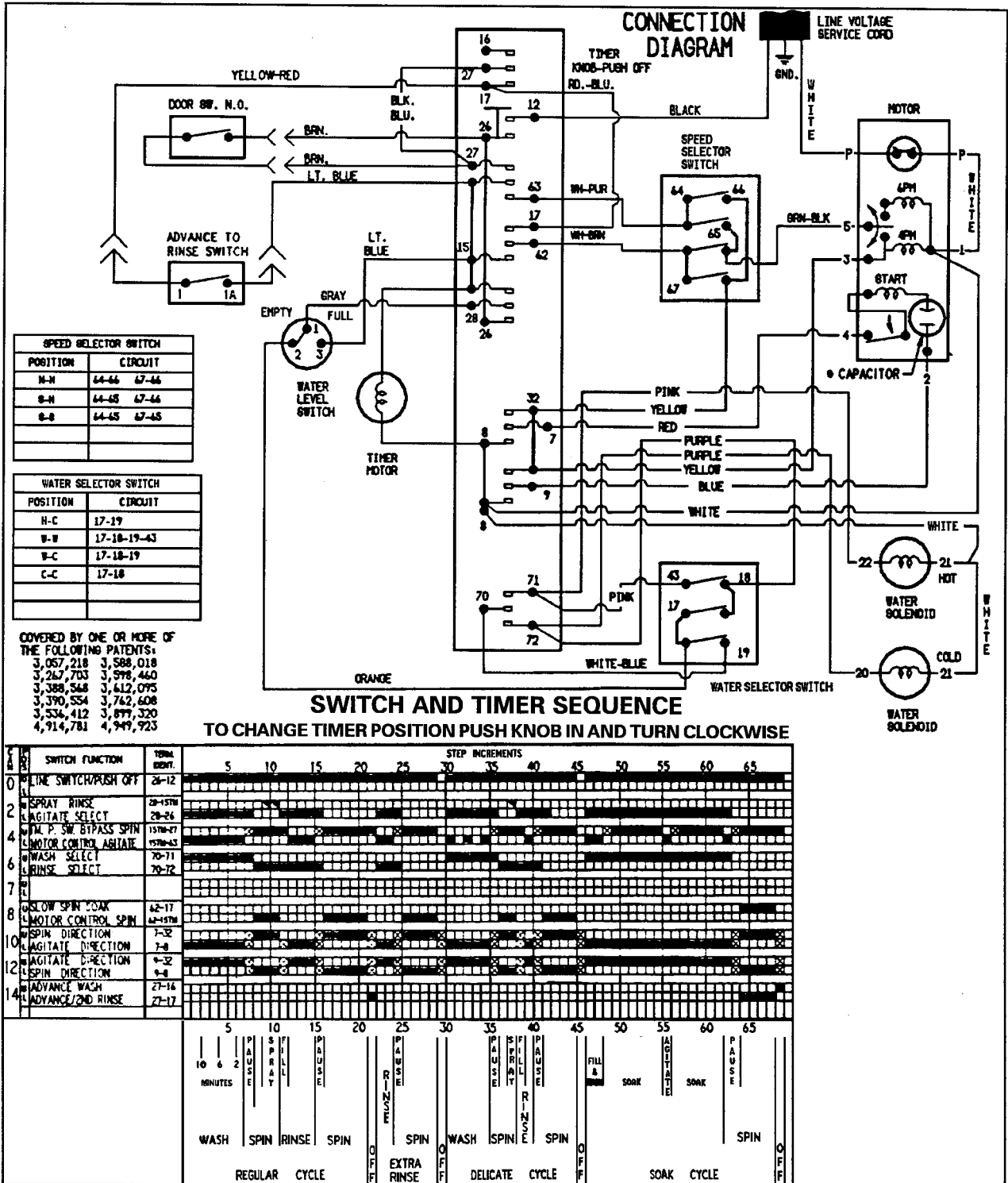

# MODEL PAV2000AWW WIRING DIAGRAM & ELECTRICAL SCHEMATIC CONT'D.

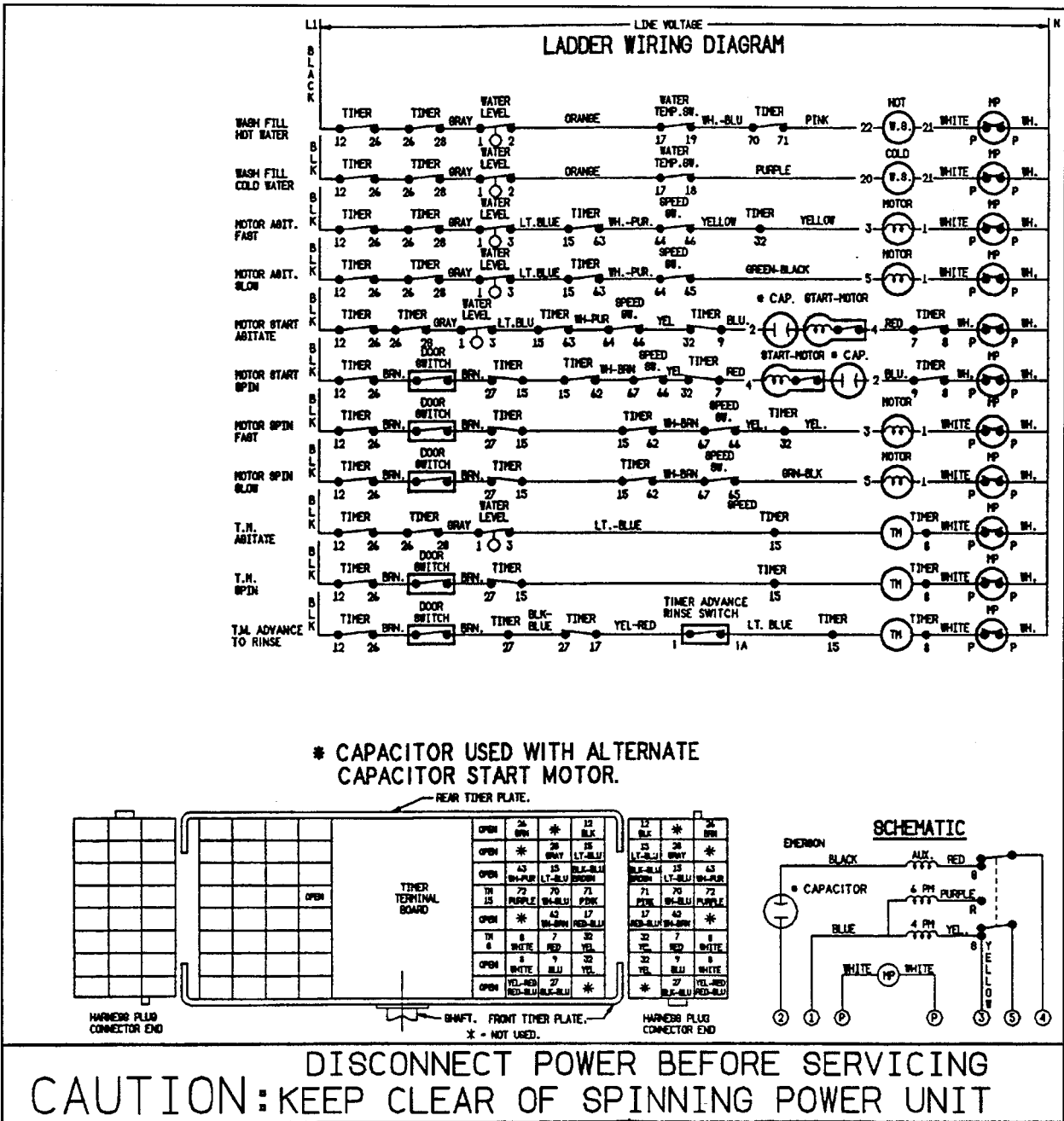

# SECTION 2. WIRING INFORMATION

DLW231

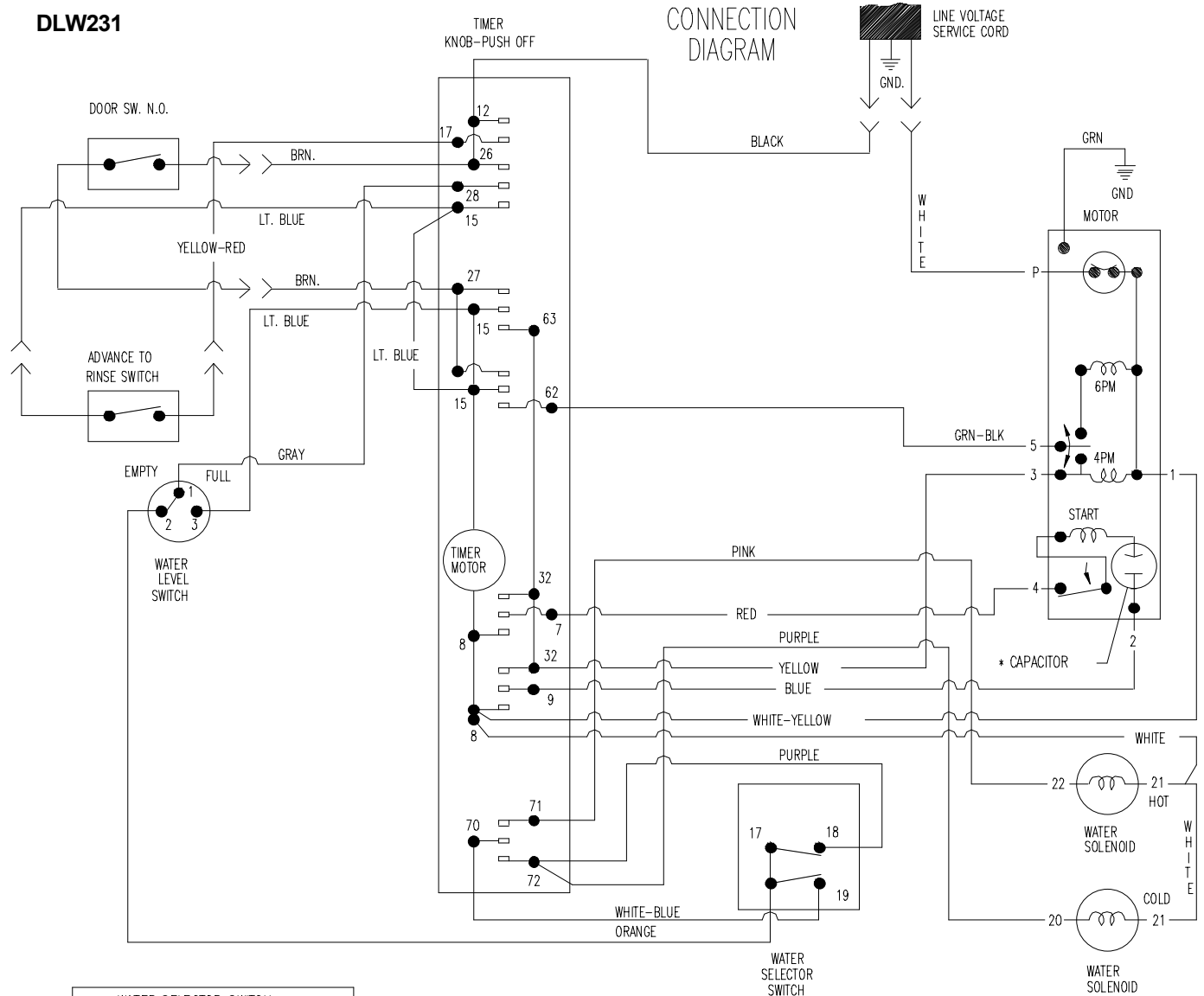

WATER SELECTOR SWITCH	
POSITION	CIRCUIT
H-C	17-19
W-W	17-18-19-43
W-C	17-18-19
C-C	17-18

## SWITCH AND TIMER SEQUENCE

TO CHANGE TIMER POSITION PUSH KNOB IN AND TURN CLOCKWISE (ALL TIMER CONTACTS WILL OPEN)

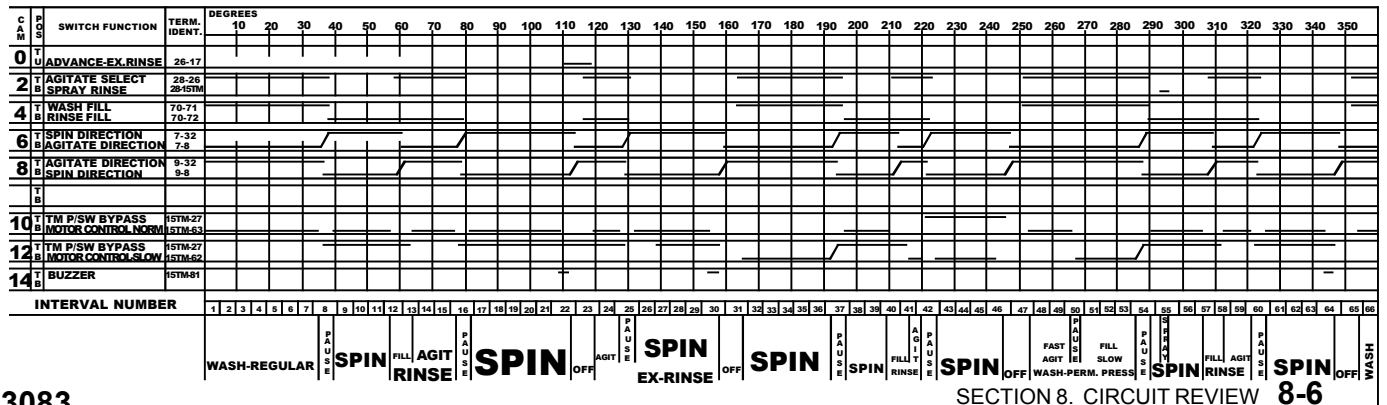

16023083

SECTION 8. CIRCUIT REVIEW 8-6

# WIRING INFORMATION

DLW231

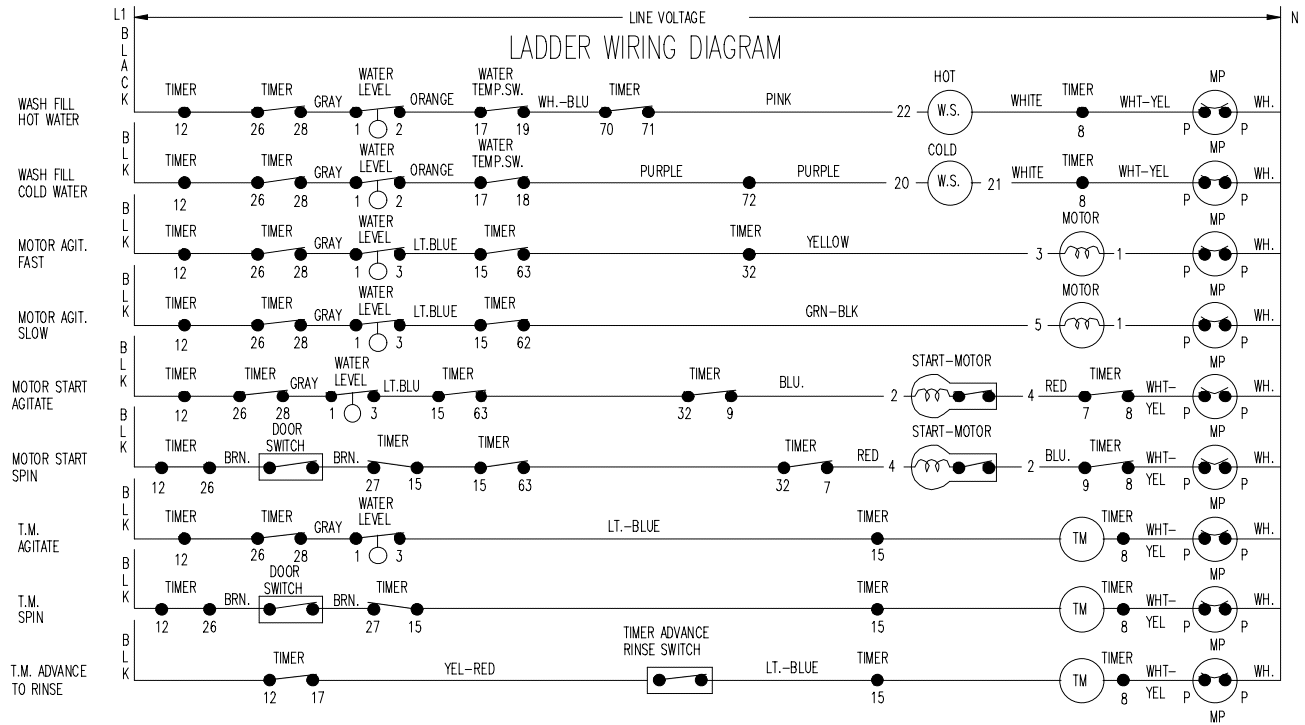

\* CAPACITOR USED WITH ALTERNATE CAPACITOR START MOTOR.

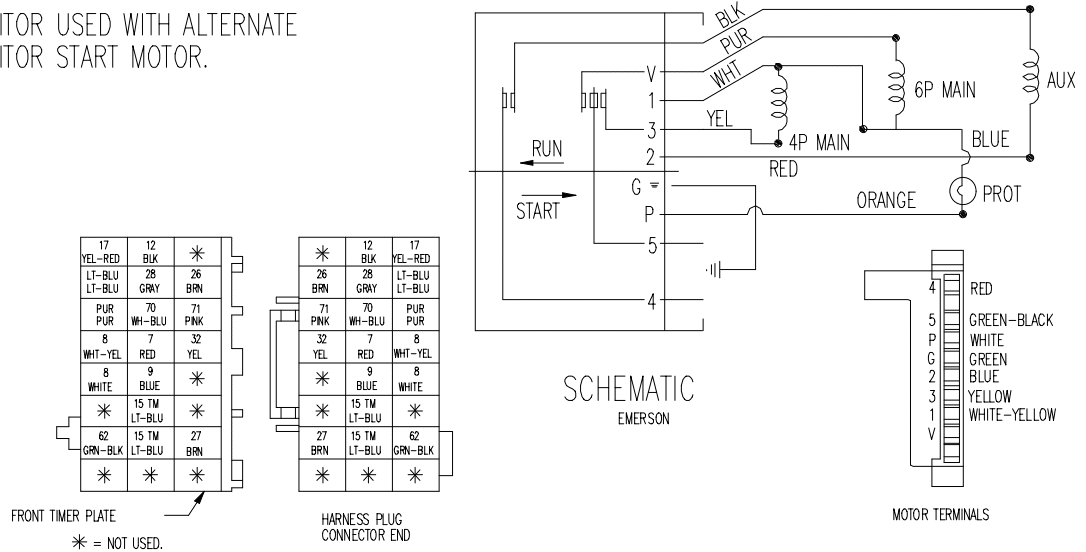

16023083

SECTION 8. CIRCUIT REVIEW 8-7

# WIRING INFORMATION

PAV2300

## CONNECTION DIAGRAM

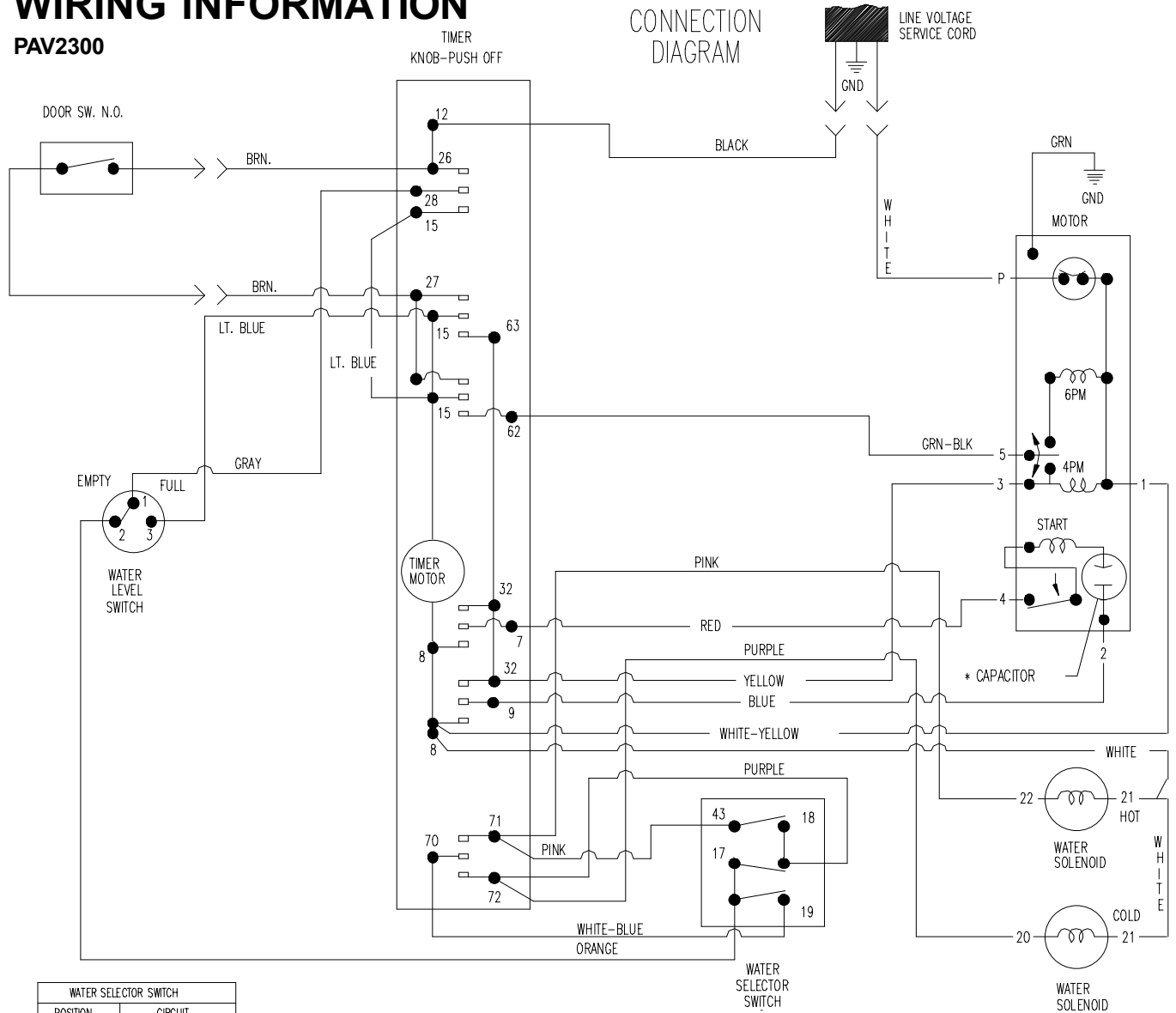

35-5878 "D"

## SWITCH AND TIMER SEQUENCE

TO CHANGE TIMER POSITION PUSH KNOB IN AND TURN CLOCKWISE (ALL TIMER CONTACTS WILL OPEN)

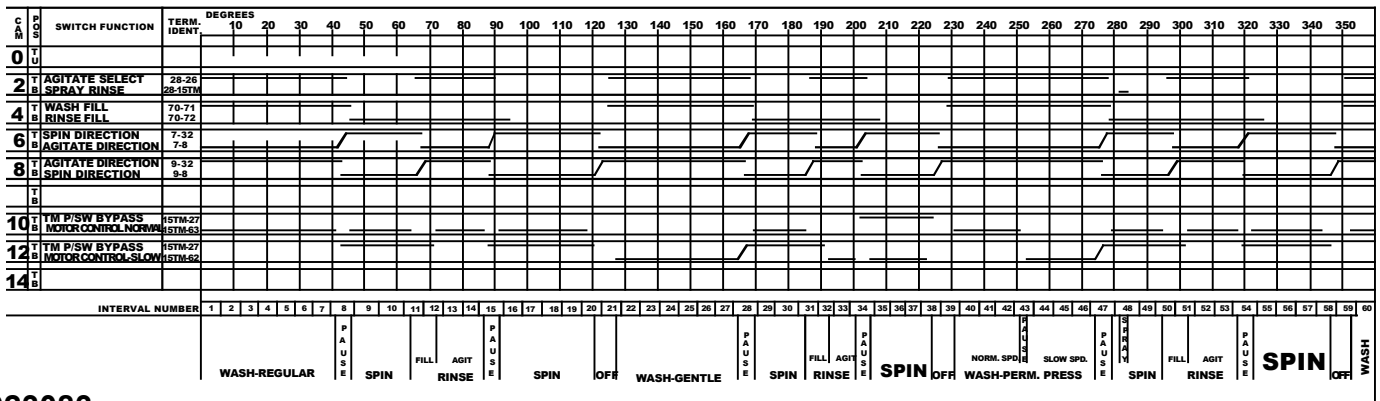

16023083

# WIRING INFORMATION

PAV2300

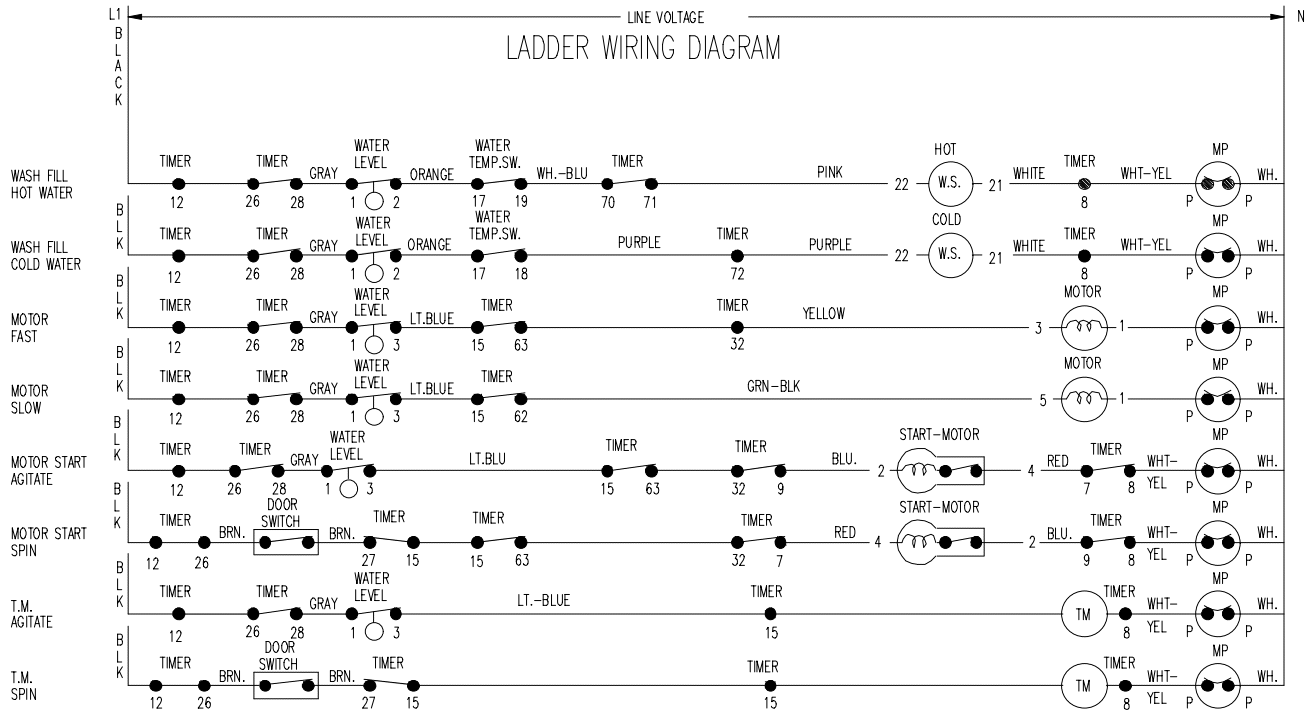

\* CAPACITOR USED WITH ALTERNATE CAPACITOR START MOTOR.

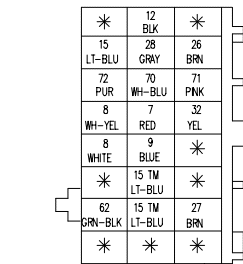

FRONT TIMER PLATE  
\* = NOT USED.

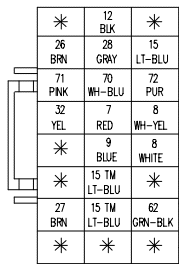

HARNESS PLUG CONNECTOR END

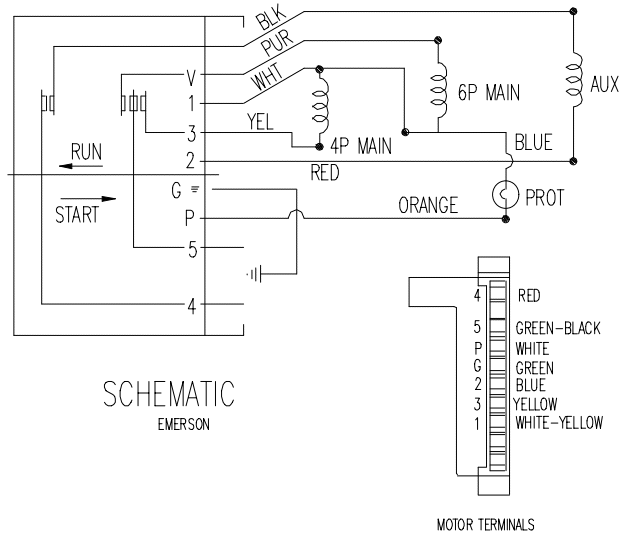

16023083

# WIRING INFORMATION

PAV3200

## CONNECTION DIAGRAM

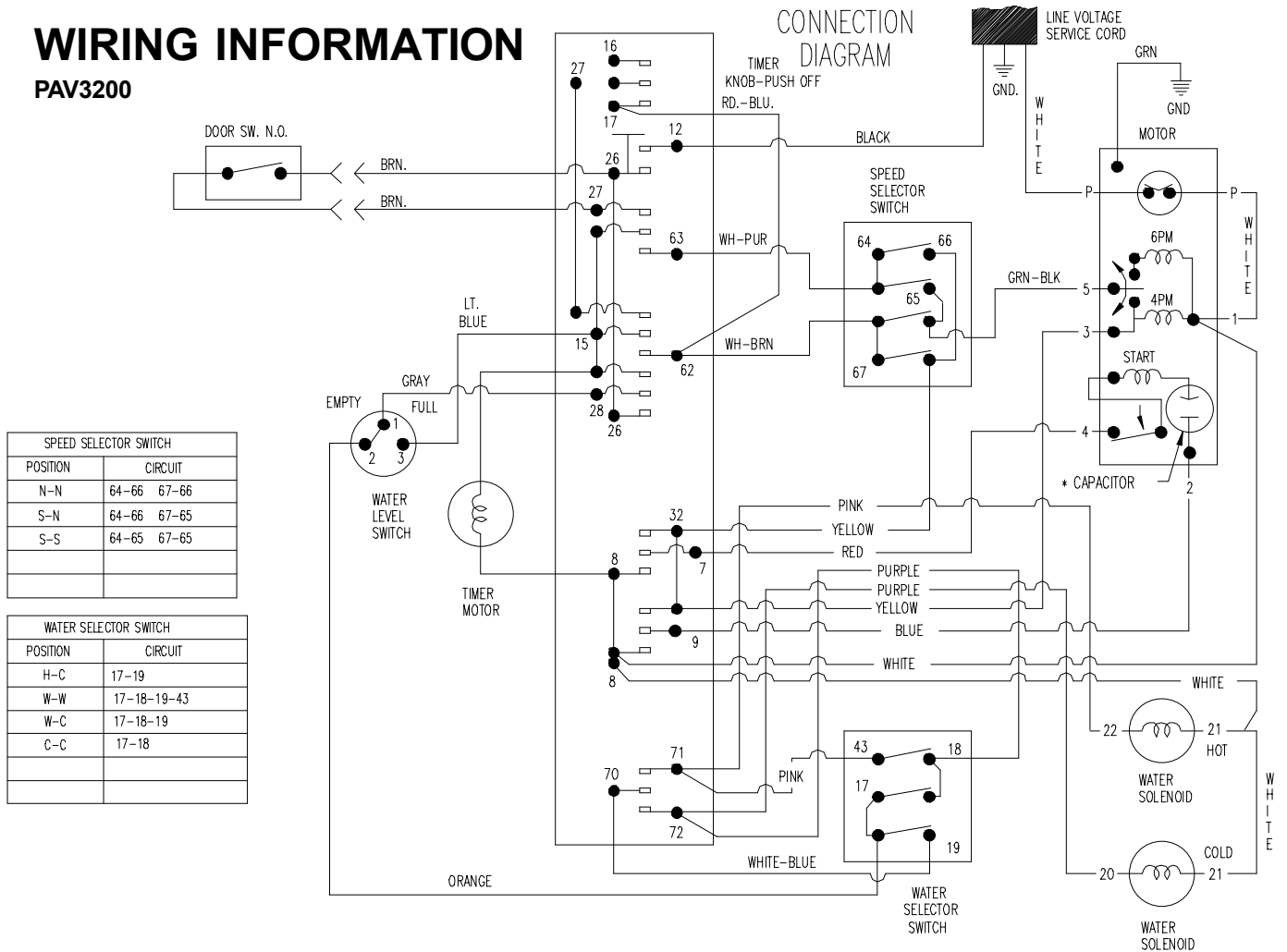

SPEED SELECTOR SWITCH		
POSITION	CIRCUIT	
N-N	64-66	67-66
S-N	64-66	67-65
S-S	64-65	67-65

WATER SELECTOR SWITCH		
POSITION	CIRCUIT	
H-C	17-19	
W-W	17-18-19-43	
W-C	17-18-19	
C-C	17-18	

## SWITCH AND TIMER SEQUENCE

TO CHANGE TIMER POSITION PUSH KNOB IN AND TURN CLOCKWISE

C A M P S	SWITCH FUNCTION	TERM. IDENT.	STEP INCREMENTS																						
			5	10	15	20	25	30	35	40	45	50	55	60	65										
0	LINESWITCH/PUSH OFF	26-12																							
1	WASH FILL	70-71																							
	RINSE FILL	70-72																							
4	SPRAY RINSE	28-15TM																							
	AGITATE SELECT	28-26																							
6	TM.P. SW. BYPASS SPIN	15TM-27																							
	MIORONROL AGITATE	15TM-63																							
9	SPIN DIRECTION	7-32																							
	AGITATE DIRECTION	7-8																							
8	MOTOR CONTROL SPIN	15TM-62																							
13	AGITATE DIRECTION	9-32																							
	SPIN DIRECTION	9-8																							
14	ADVANCE TO WASH	26-16																							
	MTR. CONT. SOAK SPIN	26-17																							

		5	10	15	20	25	30	35	40	45	50	55	60	65				
20	MINUTES	16	12	8	4													
		PAUSE	SPRAY	FILL	PAUSE	AGITATE	AGITATE	AGITATE	AGITATE	SPRAY	PAUSE	AGITATE	AGITATE	AGITATE	PAUSE			
												SOAK	AGITATE	SOAK	AGITATE	AGITATE	SPIN	PAUSE
		<b>WASH</b>				<b>SPIN RINSE SPIN</b>				<b>WASH SPIN RINSE SPIN</b>				<b>SOAK CYCLE ADVANCE TO WASH</b>				
		<b>REGULAR CYCLE</b>				<b>SHORT CYCLE</b>				<b>SOAK CYCLE</b>								

16023083



# WIRING INFORMATION

PAV3200

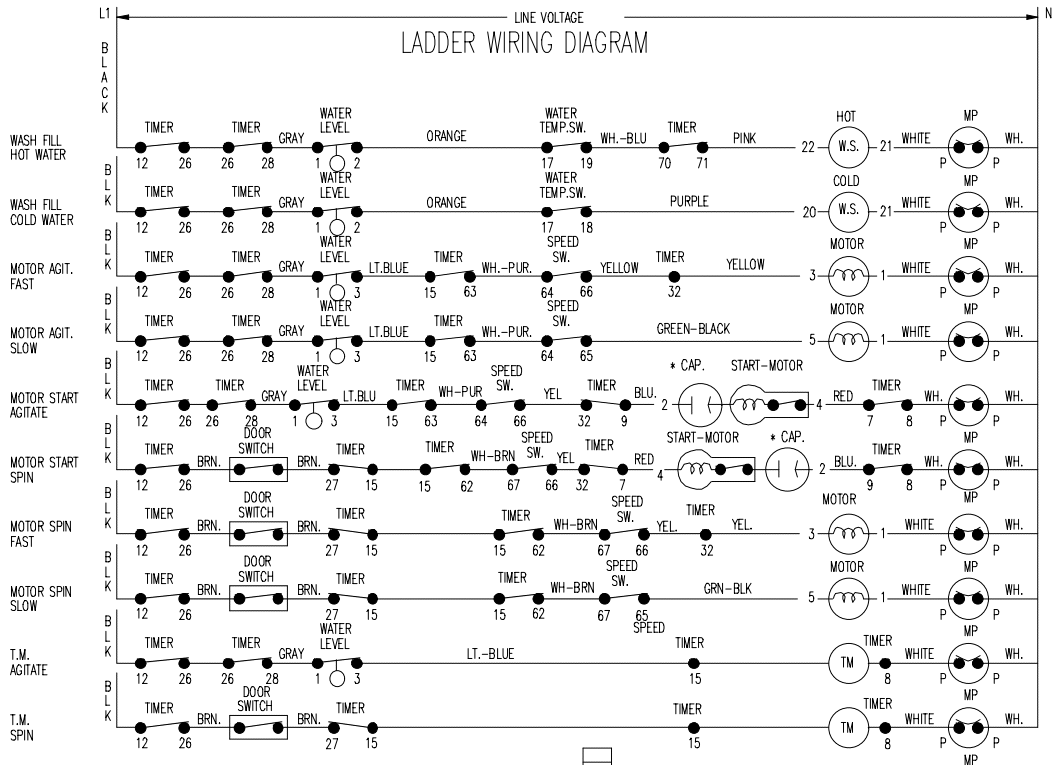

35-6094 "REL"

\* CAPACITOR USED WITH ALTERNATE CAPACITOR START MOTOR.

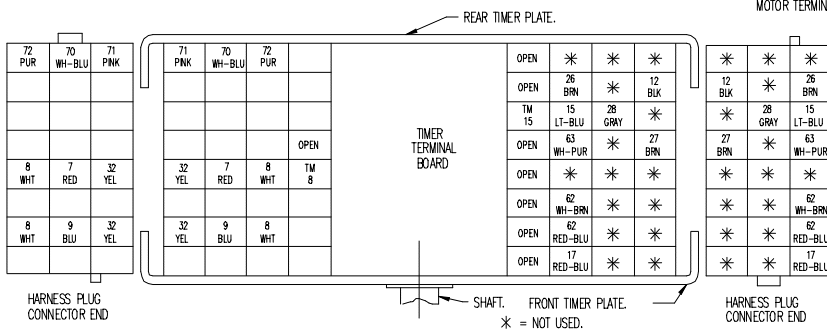
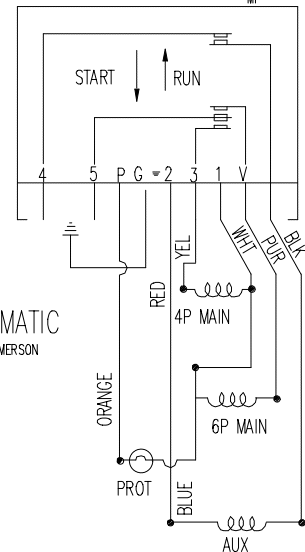
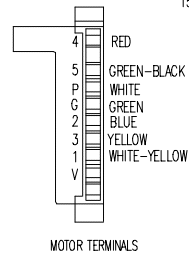

SCHEMATIC EMERSON

# WIRING INFORMATION

PAV3300

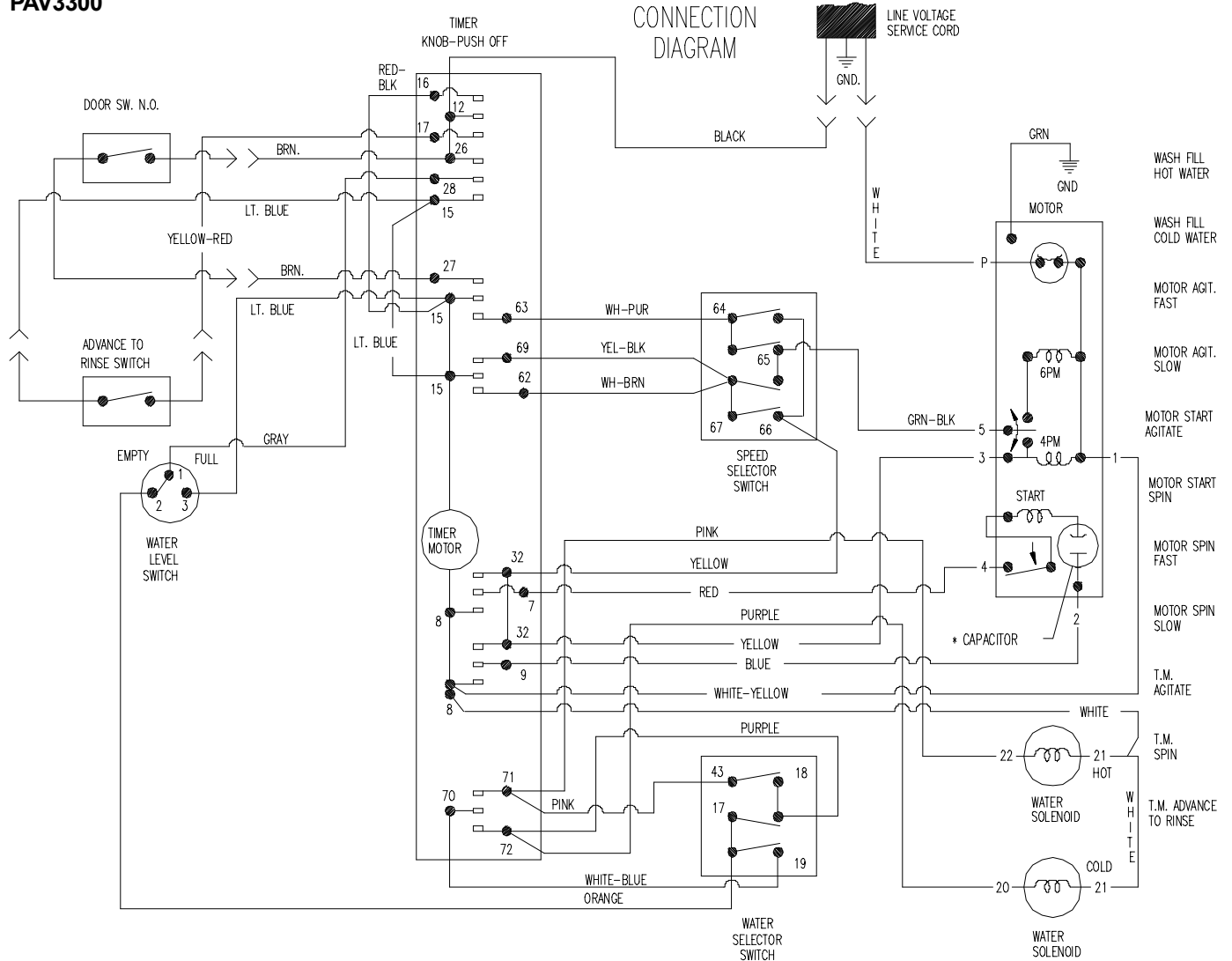

35-6193 "B"

SPEED SELECTOR SWITCH	
WASH SPEEDS	
POSITION	CIRCUIT
N-N	64-66 67-66
N-S	64-66 67-65
S-N	64-65 67-66
S-S	64-65 67-65

WATER SELECTOR SWITCH	
POSITION	CIRCUIT
H-C	17-19
W-W	17-18-19-43
W-C	17-18-19
C-C	17-18

### SWITCH AND TIMER SEQUENCE

TO CHANGE TIMER POSITION PUSH KNOB IN AND TURN CLOCKWISE (ALL TIMER CONTACTS WILL OPEN)

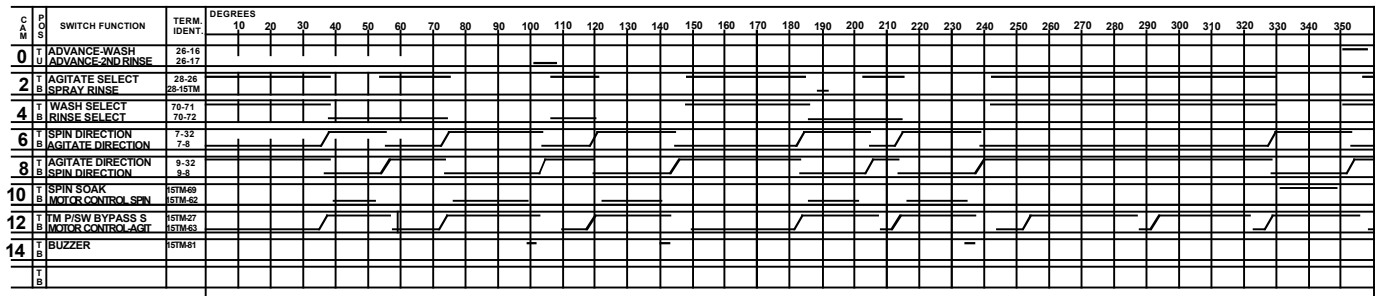

16023083

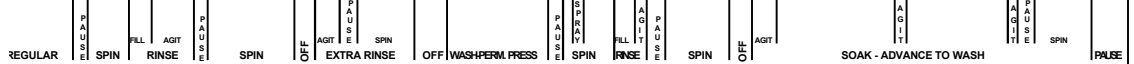

# WIRING INFORMATION

PAV3300

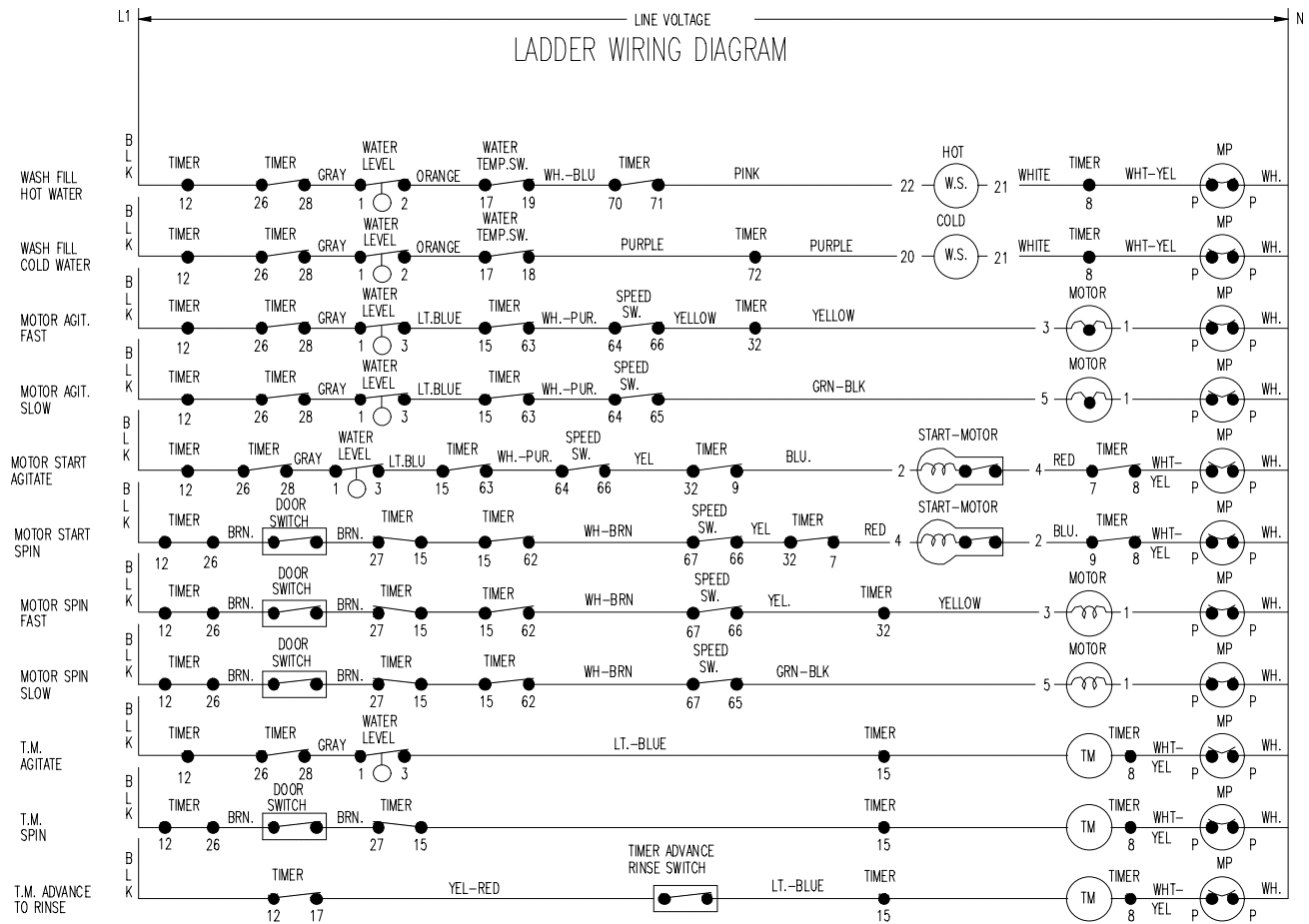

\* CAPACITOR USED WITH ALTERNATE CAPACITOR START MOTOR.

17 YEL-RED	12 BLK	16 RD-BLK
LT-BLU	28 GRAY	25 BRN
PUR	70 WH-BLU	71 PINK
7 WHITE-YELLOW	32 YEL	32 WHITE-YELLOW
9 WHITE	9 BLUE	32 WHITE
62 WH-BRN	RD-BLK	69 YEL-BLK
63 WH-PUR	15 TM LT-BLU	27 BRN

FRONT TIMER PLATE  
\* = NOT USED.

15 RD-BLK	12 BLK	17 YEL-RED
26 BRN	28 GRAY	LT-BLU
PINK	70 WH-BLU	PUR
32 YEL	7 RED	7 WHITE-YELLOW
32 YEL	9 BLUE	8 WHITE
69 YEL-BLK	RD-BLK	62 WH-BRN
27 BRN	15 TM LT-BLU	63 WH-PUR

HARNES PLUG CONNECTOR END

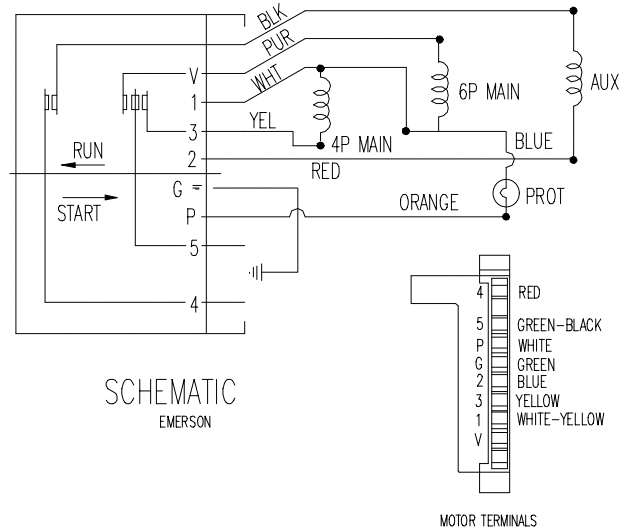

SCHEMATIC  
EMERSON

4	RED
5	GREEN-BLACK
P	WHITE
G	GREEN
3	BLUE
2	YELLOW
1	WHITE-YELLOW
V	

MOTOR TERMINALS

16023083

# WIRING INFORMATION

PAV5000

## CONNECTION DIAGRAM

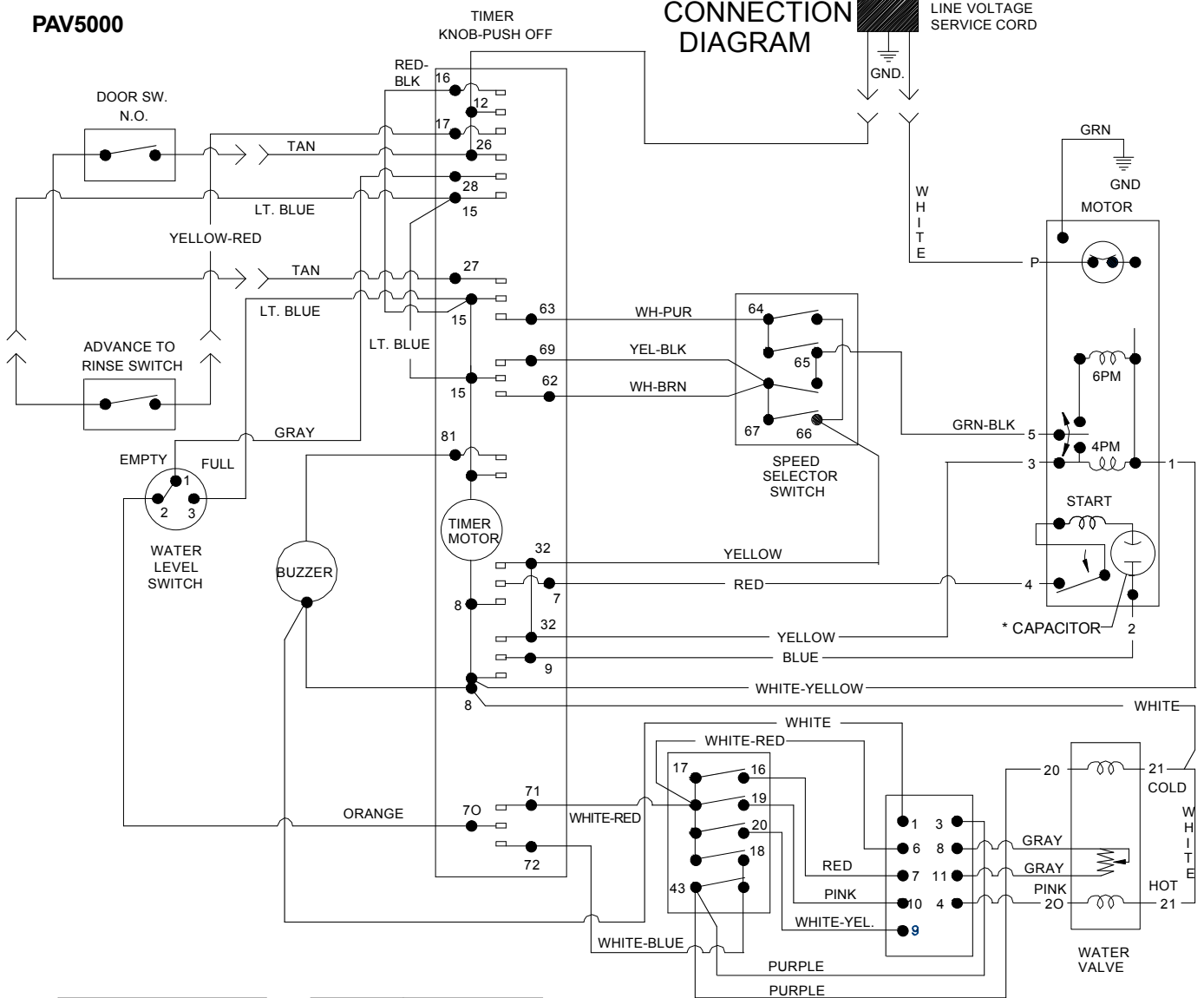

SPEED SELECTOR SWITCH	
WASH SPEEDS	
POSITION	CIRCUIT
	64-66 67-66
N-S	64-66 67-65
S-N	64-65 67-66
S-S	64-65 67-65

POSITION	CIRCUIT
H-C	17-19-16, 18-43
W-C	17-16-19-20, 18-43
C-C	17-16-20, 18-43
ATCW-W	17-18-19-20
ATCW-C	17-20-19, 18-43
ATCC-C	17-20, 18-43

35-6345 "B"

### SWITCH AND TIMER SEQUENCE

TO CHANGE TIMER POSITION PUSH KNOB IN AND TURN CLOCKWISE (ALL TIMER CONTACTS WILL OPEN)

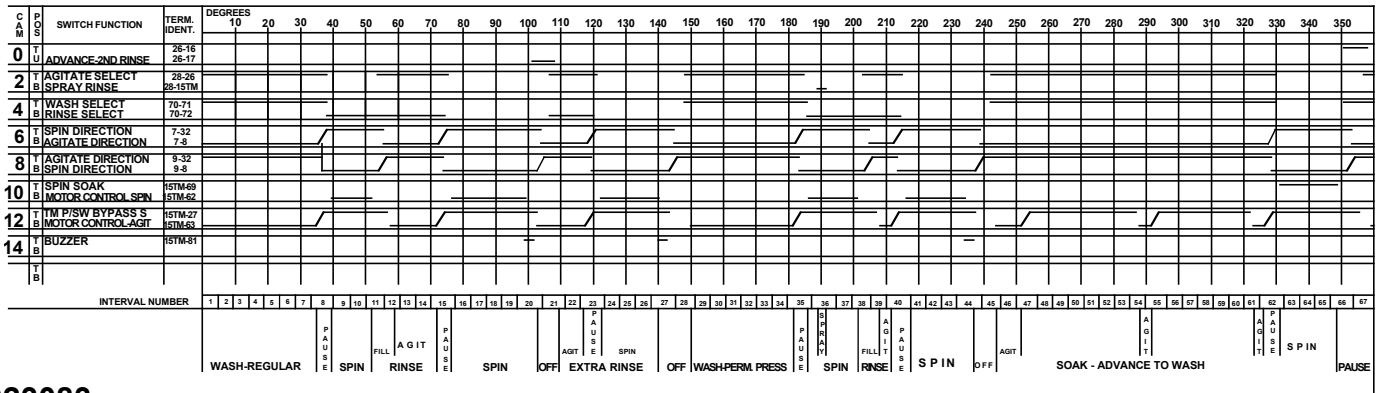

16023083

# WIRING INFORMATION

PAV5000

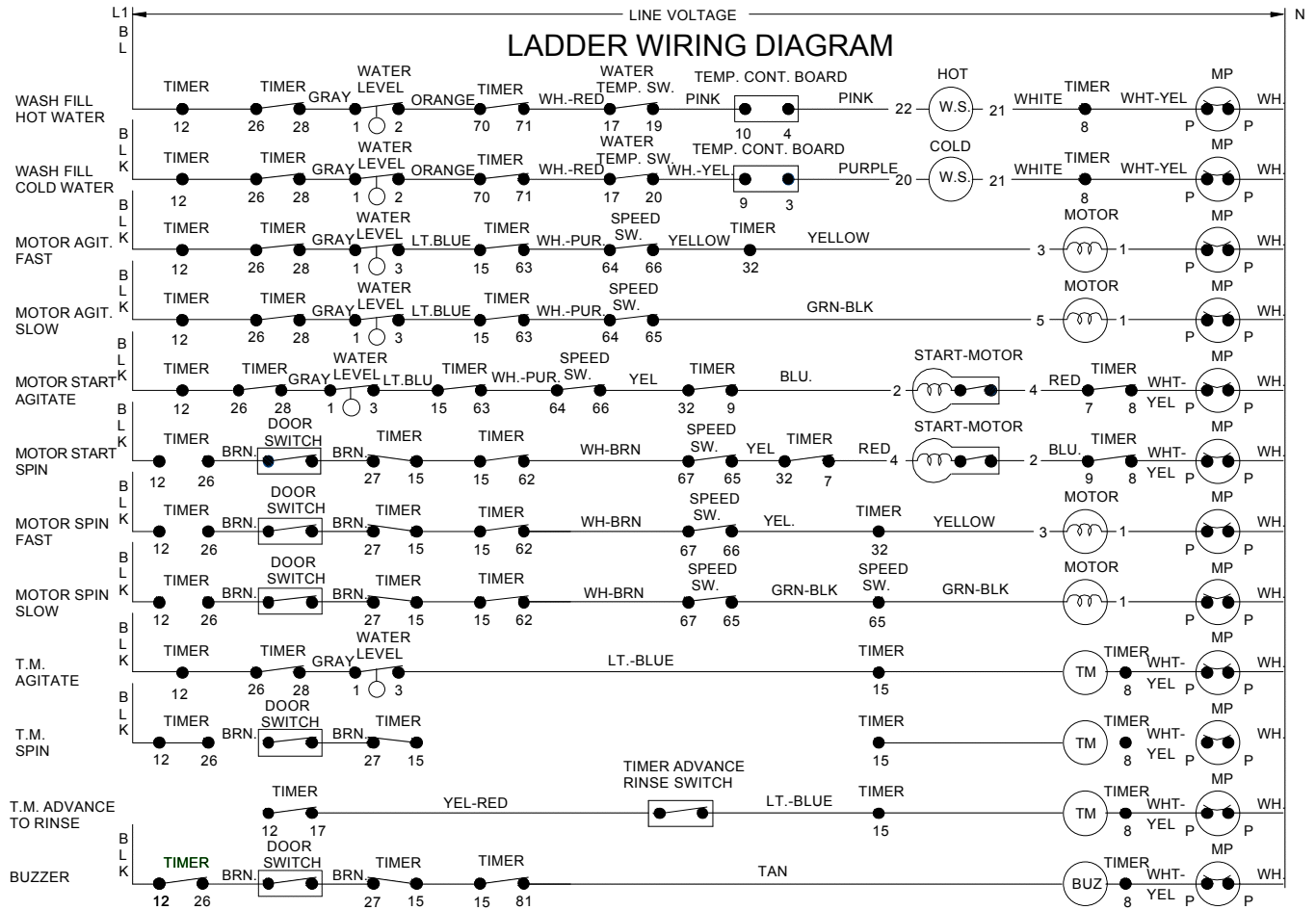

\* CAPACITOR USED WITH ALTERNATE CAPACITOR START MOTOR.

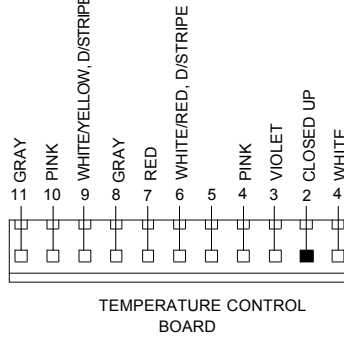

17	12	16
YEL-RED	BLK	RD-BLK
LT-BLU	28	26
LT-BLU	GRAY	BRN
72	70	71
WH-BLU	ORANG	WH-RED
WHITE-YELLOW	7	32
WHITE	RED	YEL
WHITE	9	32
WHITE	BLUE	YEL
62	RD-BLK	69
WHBRN	LT-BLU	YEL-BLK
63	15 TM	27
WH-PUR	LT-BLU	BRN
*	*	81
		TAN

16	12	17
RD-BLK	BLK	YEL-RED
26	28	LT-BLU
BRN	GRAY	LT-BLU
71	70	72
WH-RED	ORANGE	WH-BLU
32	7	WHITE-YELLOW
YEL	RED	WHITE
32	9	WHITE
YEL	BLUE	WHITE
69	RD-BLK	62
YEL-BLK	LT-BLU	WH-BRN
27	15 TM	63
BRN	LT-BLU	WH-PUR
81	TAN	*
		*

FRONT TIMER PLATE  
\* = NOT USED.

HARNES PLUG CONNECTOR END

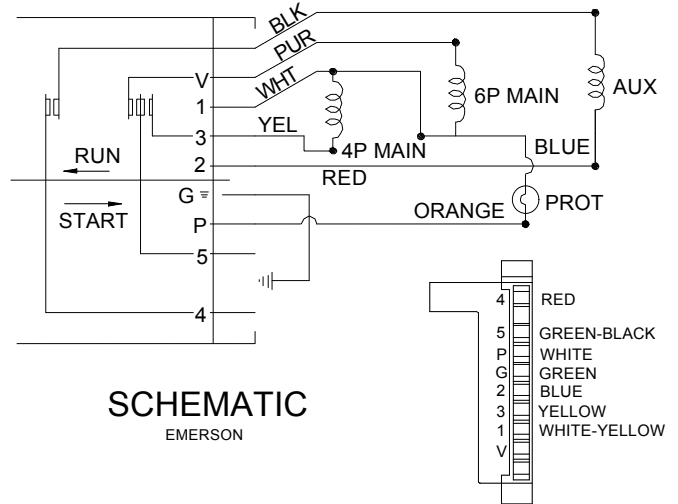

16023083

# WIRING INFORMATION

PAV5157, PAV5158

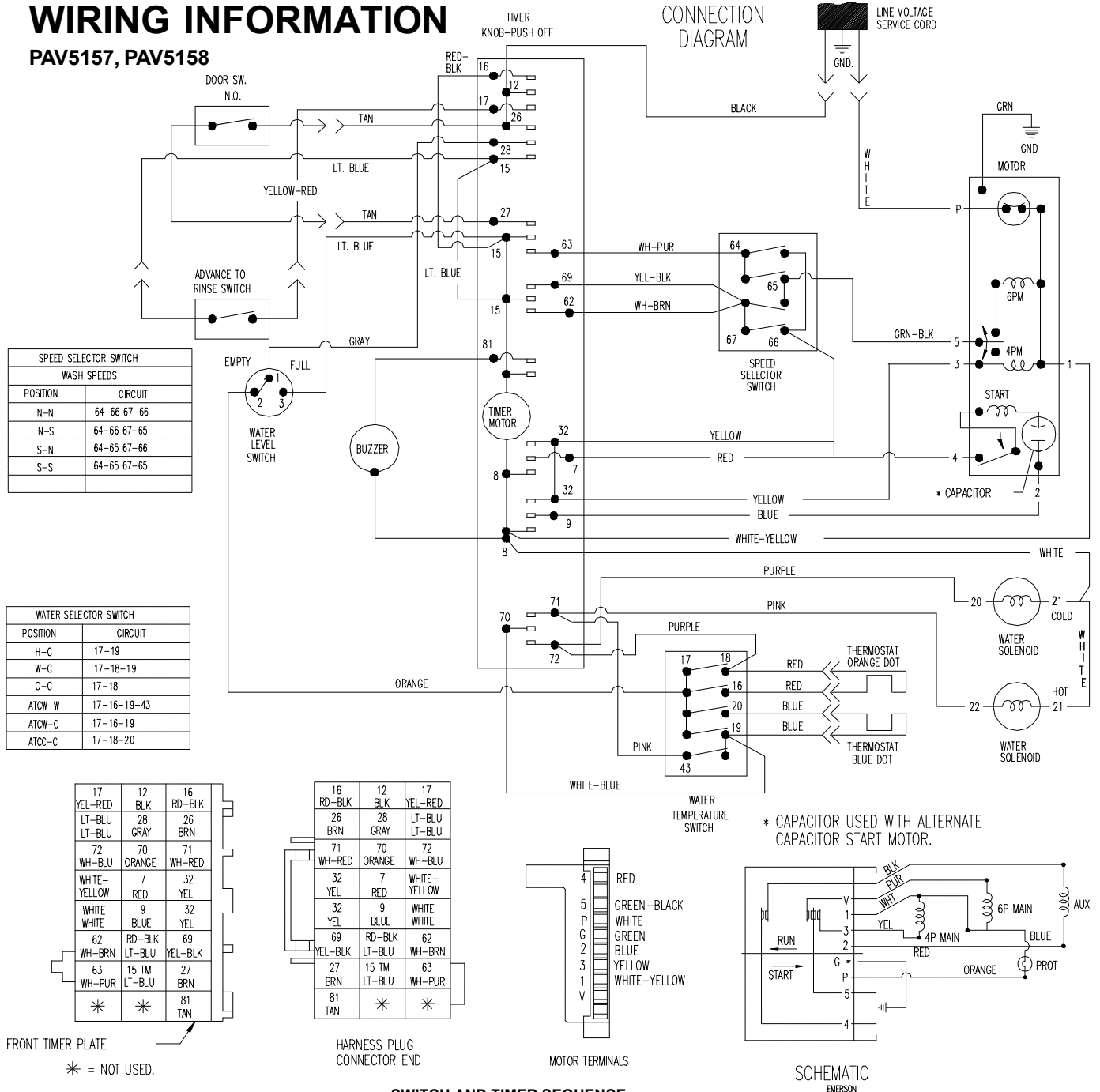

SPEED SELECTOR SWITCH	
WASH SPEEDS	
POSITION	CIRCUIT
N-N	64-66 67-66
N-S	64-66 67-65
S-N	64-65 67-66
S-S	64-65 67-65

WATER SELECTOR SWITCH	
POSITION	CIRCUIT
H-C	17-19
W-C	17-18-19
C-C	17-18
ATCW-W	17-16-19-43
ATCW-C	17-16-19
ATCC-C	17-18-20

17	12	16
YEL-RED	BLK	RD-BLK
LT-BLU	28	26
LT-BLU	GRAY	BRN
72	70	71
WH-BLU	ORANGE	WH-RED
WHITE-YELLOW	7	32
WHITE	9	32
WHITE	BLUE	YEL
62	RD-BLK	69
WH-BRN	LT-BLU	YEL-BLK
63	15 TM	27
WH-PUR	LT-BLU	BRN
*	*	81
		TAN

16	12	17
RD-BLK	BLK	YEL-RED
26	28	LT-BLU
BRN	GRAY	LT-BLU
71	70	72
WH-RED	ORANGE	WH-BLU
32	7	WHITE-YELLOW
32	9	WHITE
YEL	BLUE	WHITE
69	RD-BLK	62
YEL-BLK	LT-BLU	WH-BRN
27	15 TM	63
BRN	LT-BLU	WH-PUR
81	*	*
TAN		

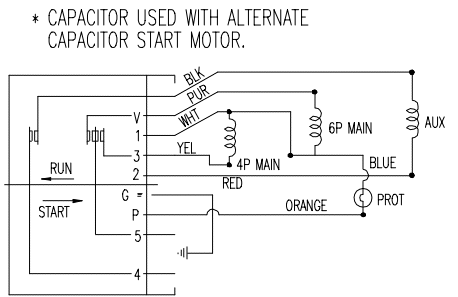
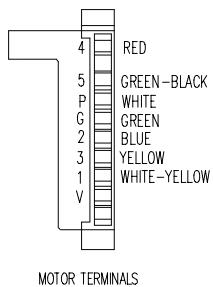

FRONT TIMER PLATE  
\* = NOT USED.

HARNES PLUG CONNECTOR END

MOTOR TERMINALS

SCHEMATIC  
EMERSON

## SWITCH AND TIMER SEQUENCE

TO CHANGE TIMER POSITION PUSH KNOB N AND TURN CLOCKWISE (ALL TIMER CONTACTS WILL OPEN)

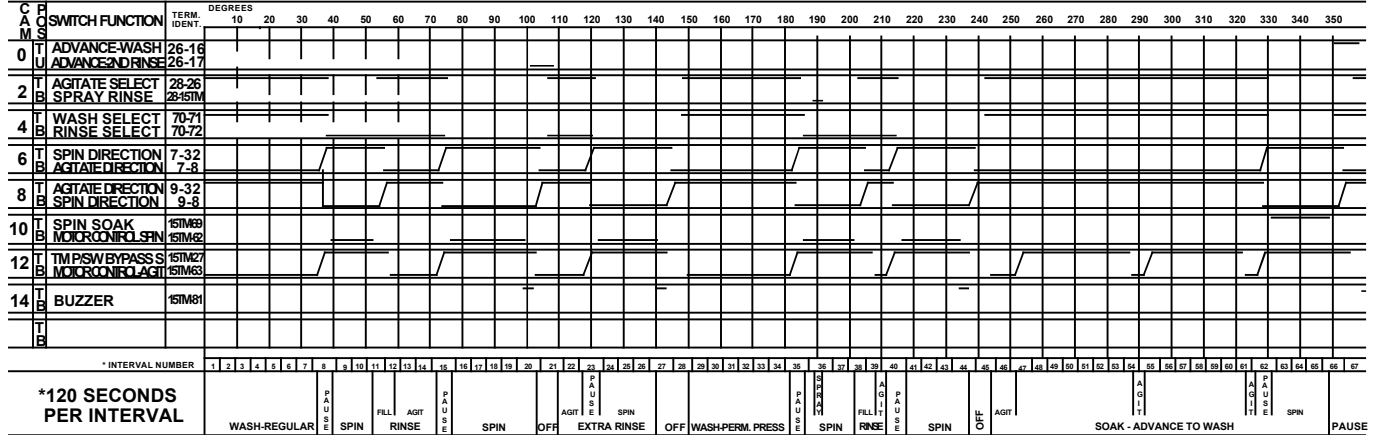

# WIRING INFORMATION

PAV5157, PAV5158

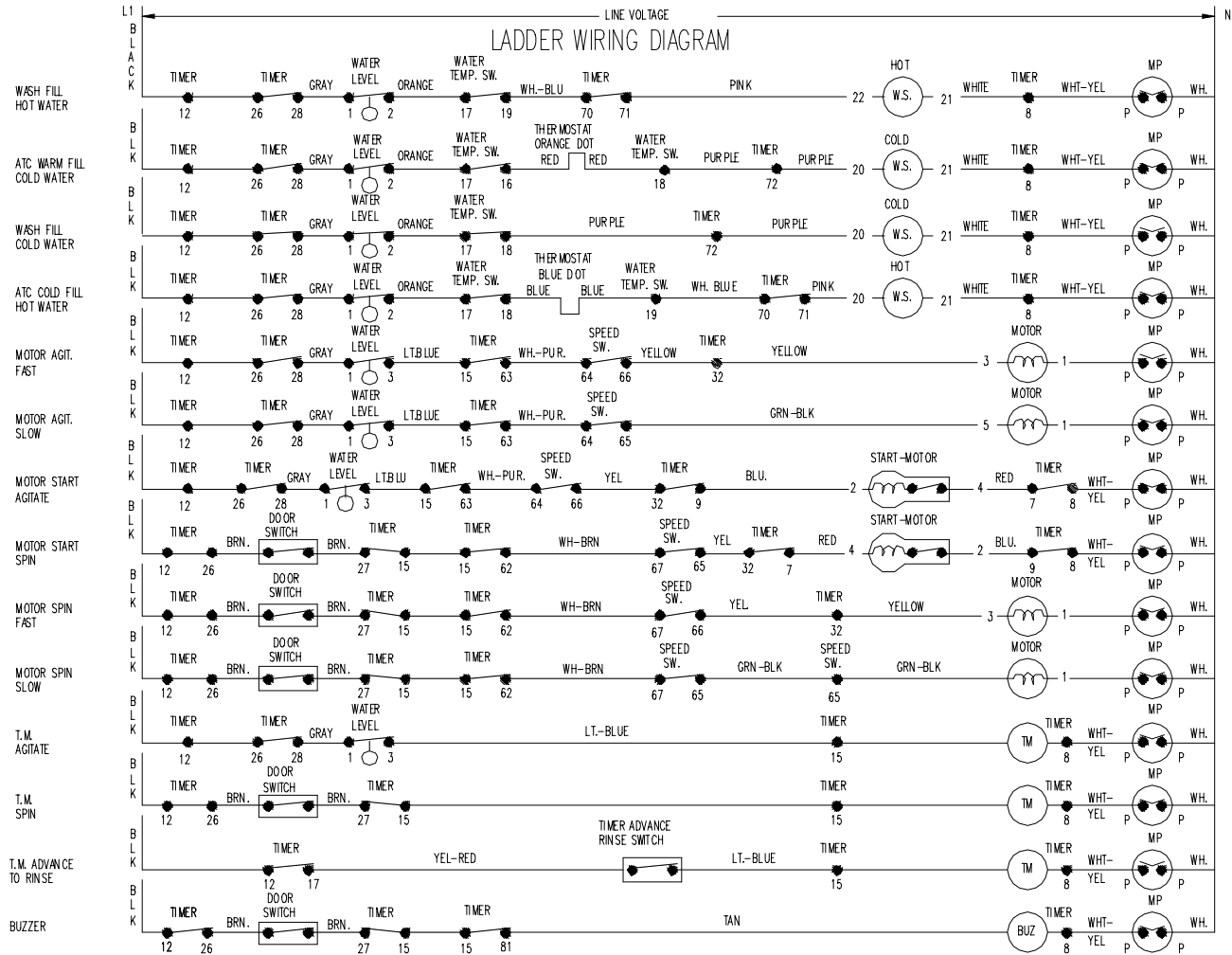

### Function of ATC

ATC Cold Fill— The ATC cold fill toggles from cold to warm in order to boost cold wash water temp to approximately 75 degrees minimum.

ATC Warm Fill— The ATC warm fill toggles from hot to warm in order to boost the warm water temperature to approximately 95 degrees minimum.

\* NOTE: ATC does not function forrinse

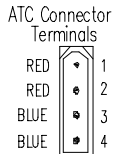

Water temperature	Wire Color	Circuit
<60 degrees	RD to RD	open
<60 degrees	BU to BU	closed
>110 degrees	RD to RD	closed
>110 degrees	BU to BU	open

To properly test ATC thermostats follow the steps below:

\*IMPORTANT: To protect meter all continuity checks must be made on the connector end going to thermostats.

- Step 1. Disconnect 4-wire plug connector located in backguard coming from water flume thermostats.
- Step 2. Set water temperature selection for cold water fill and allow washer to fill for 2 minutes. Confirm water temperature entering washer is < 60 degrees and make continuity checks per table.
- Step 3. Set water temperature selection for hot water fill and allow washer to fill for 2 minutes. Confirm water temperature entering washer is > 110 degrees and make continuity checks per table.
- Step 4. If results of continuity checks do not correspond to table and all wiring is proper, replace ATC flume thermostat accordingly.

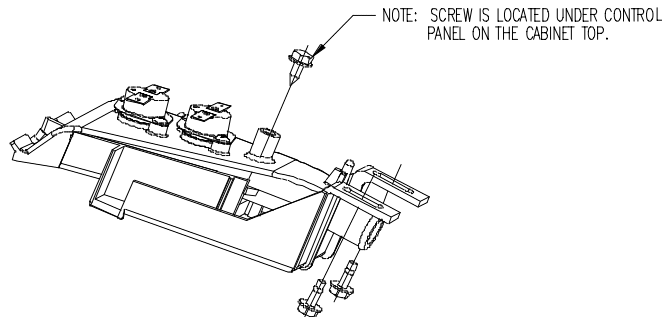

16023083

# WIRING INFORMATION

PAVT344

TIMER  
KNOB-PUSH OFF

## CONNECTION DIAGRAM

LINE VOLTAGE  
SERVICE CORD

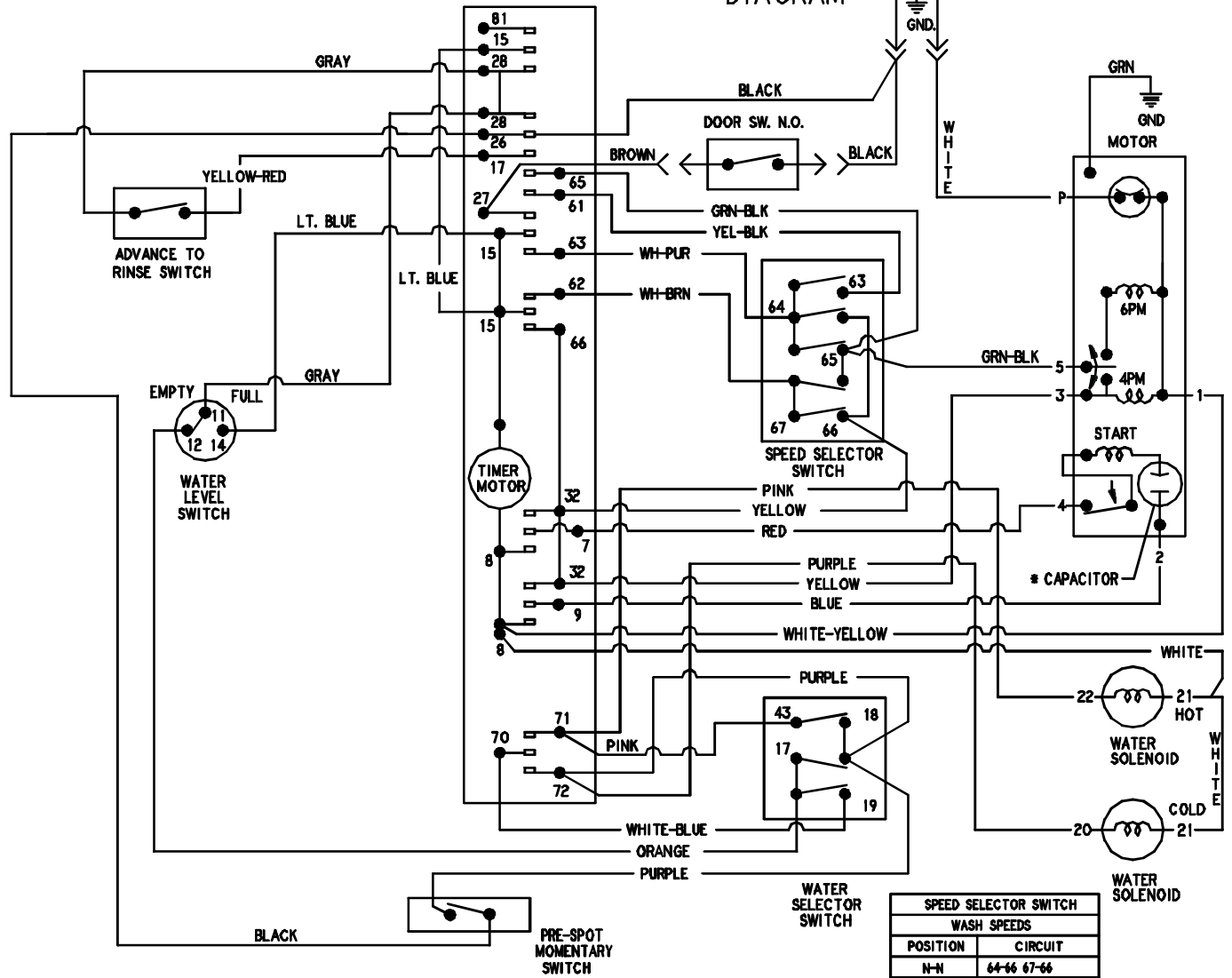

SPEED SELECTOR SWITCH	
WASH SPEEDS	
POSITION	CIRCUIT
N-N	64-66 67-66
N-S	64-66 67-65
S-S	65-64-67
X-S-S	64-63 65-67

WATER SELECTOR SWITCH	
POSITION	CIRCUIT
H-C	17-19
W-W	17-18-19-43
W-C	17-18-19
C-C	17-18

### SWITCH AND TIMER SEQUENCE

TO CHANGE TIMER POSITION PUSH KNOB IN AND TURN CLOCKWISE (ALL TIMER CONTACTS WILL OPEN)

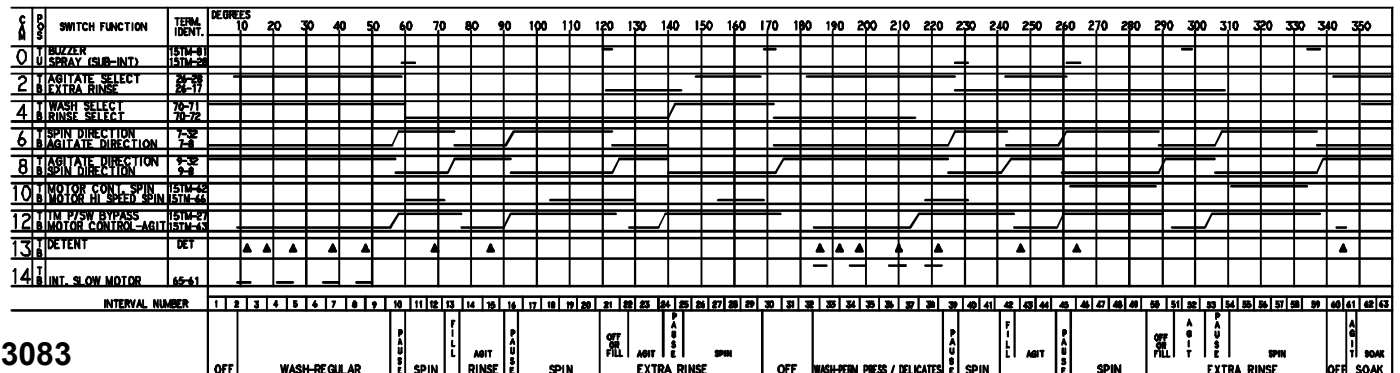

16023083



# WIRING INFORMATION

PAVT344

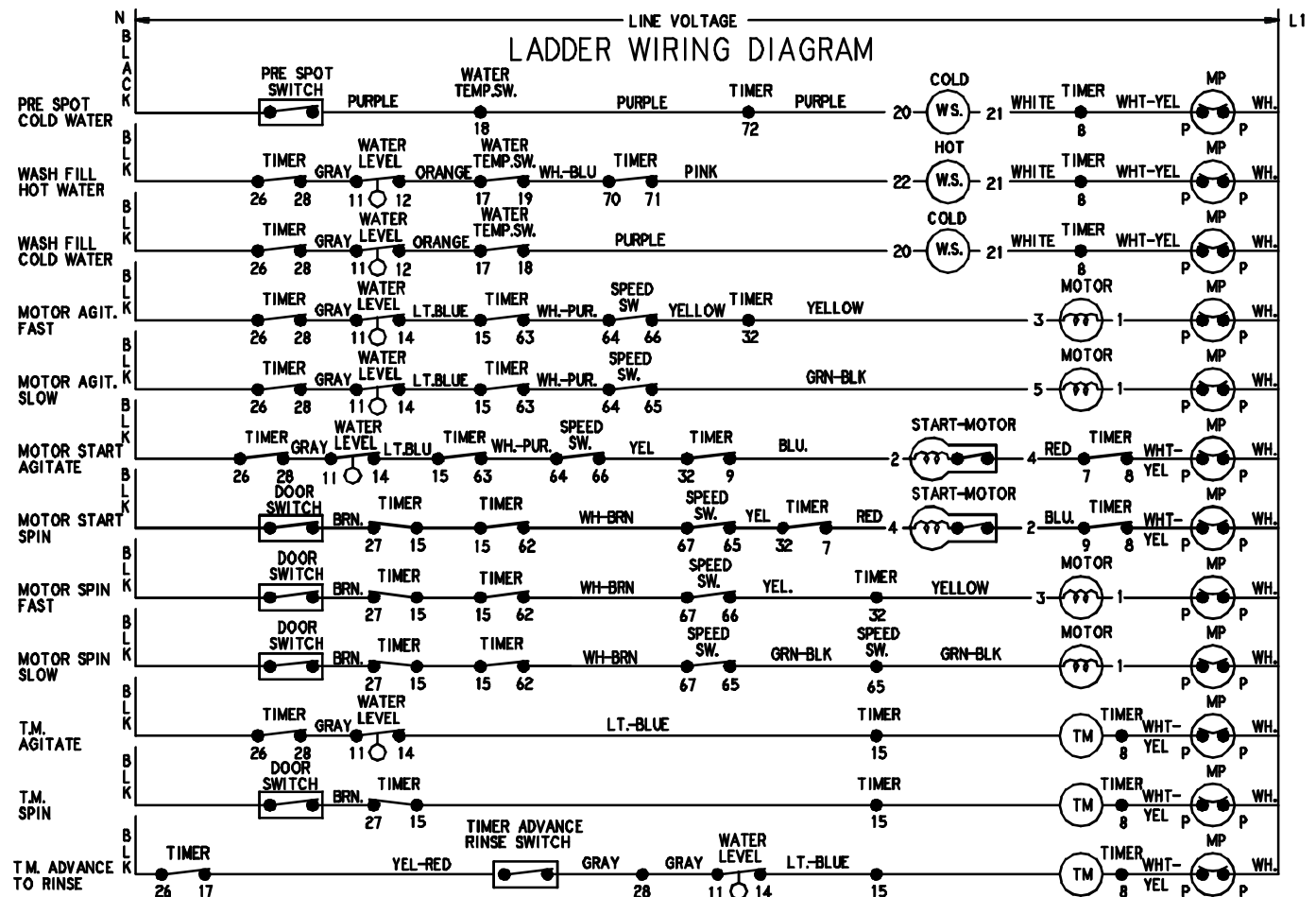

\* CAPACITOR USED WITH ALTERNATE CAPACITOR START MOTOR.

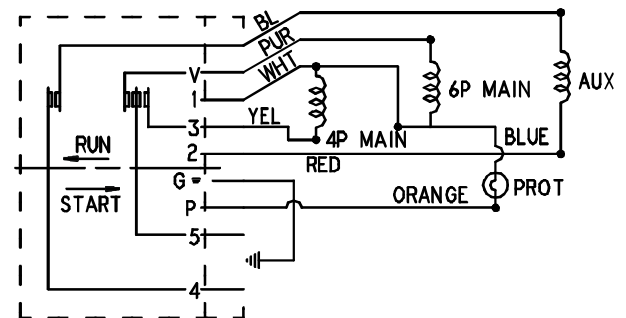
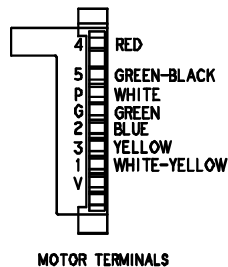
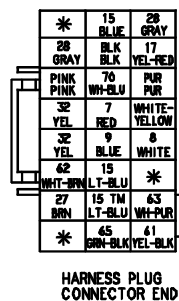
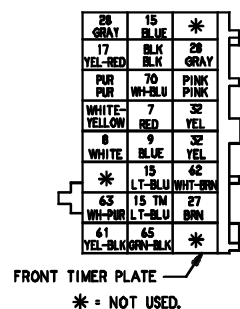

SWITCH AND TIMER SEQUENCE

16023083

# WIRING INFORMATION

HAV2460

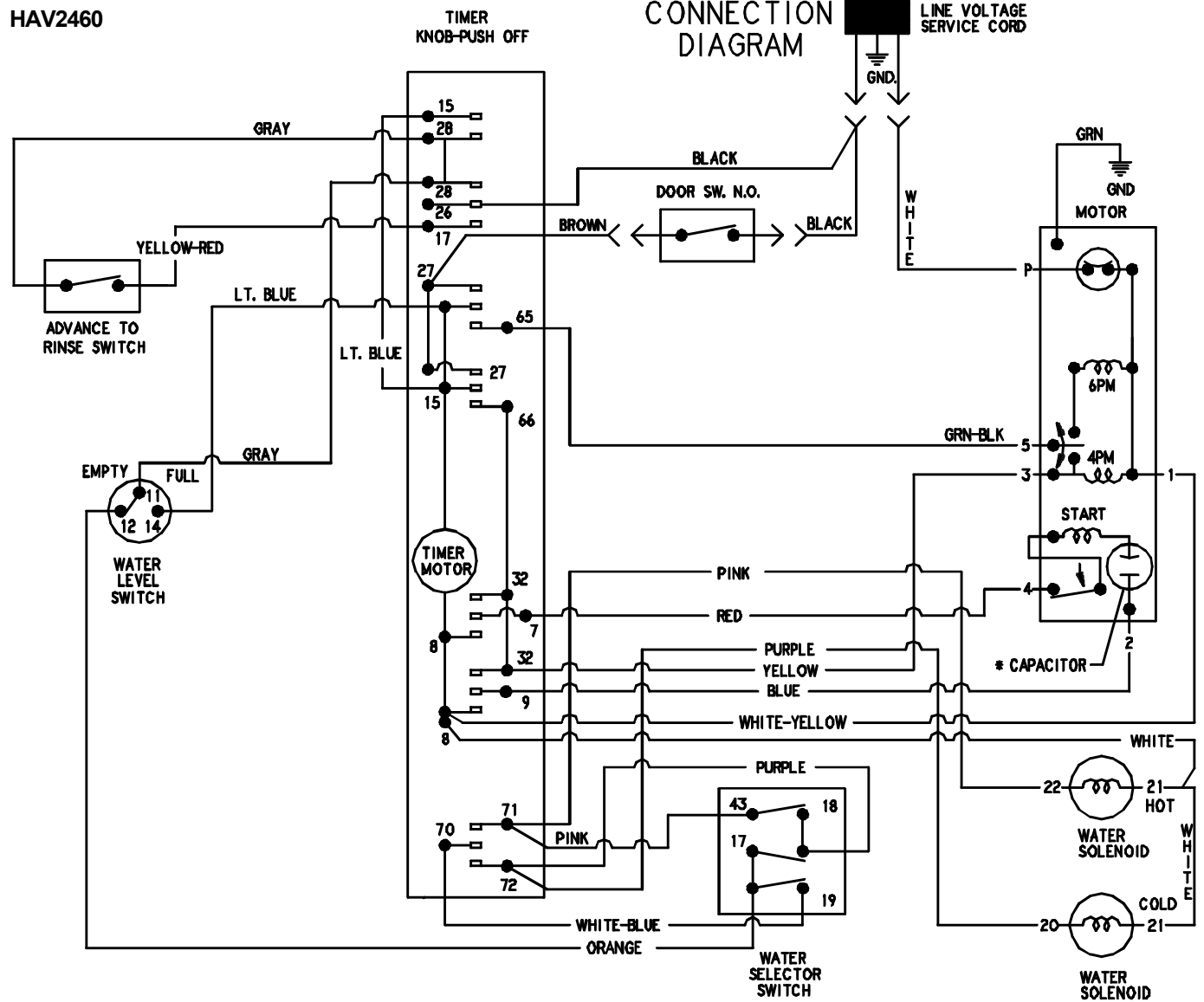

WATER SELECTOR SWITCH	
POSITION	CIRCUIT
H-C	17-19
W-W	17-18-19-43
W-C	17-18-19
C-C	17-18

SWITCH AND TIMER SEQUENCE  
TO CHANGE TIMER POSITION PUSH KNOB IN AND TURN CLOCKWISE (ALL TIMER CONTACTS WILL OPEN)

C	P	S	SWITCH FUNCTION	TERMIN. IDENT.	DEGREES																																																
					10	20	30	40	50	60	70	80	90	100	110	120	130	140	150	160	170	180	190	200	210	220	230	240	250	260	270	280	290	300	310	320	330	340	350														
0	I		SPRAY (SUB-INT)	28-15TM																																																	
2	I		AGITATE SELECT	28-24																																																	
2	B		EXTRA RINSE	28-17																																																	
4	I		WASH SELECT	70-71																																																	
4	B		RINSE SELECT	70-72																																																	
6	I		SPIN DIRECTION	7-38																																																	
6	B		AGITATE DIRECTION	7-8																																																	
8	I		AGITATE DIRECTION	9-32																																																	
8	B		SPIN DIRECTION	9-8																																																	
10	I		TIM P1/SW BYPASS	15TM-27																																																	
10	B		MOTOR CONTROL-NORMAL	15TM-44																																																	
12	I		TIM P1/SW BYPASS	15TM-27																																																	
12	B		MOTOR CONTROL-SLOW	15TM-66																																																	
13	I		DE TENT	DE.T.																																																	
13	B																																																				
14	I																																																				
14	B																																																				

16023083

# WIRING INFORMATION

HAV2460

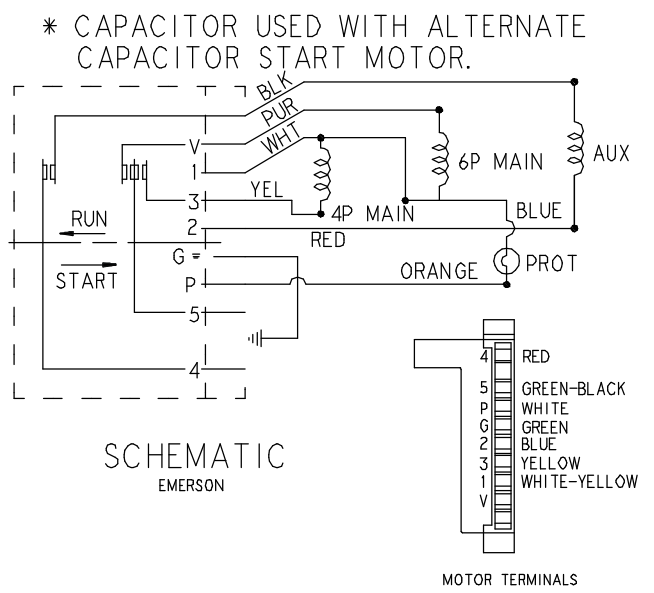
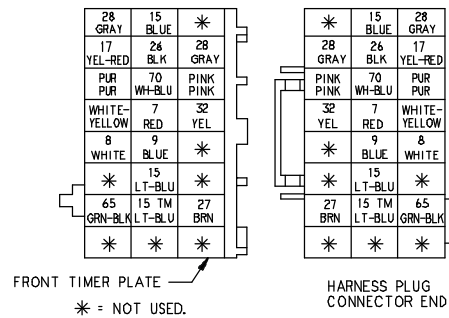
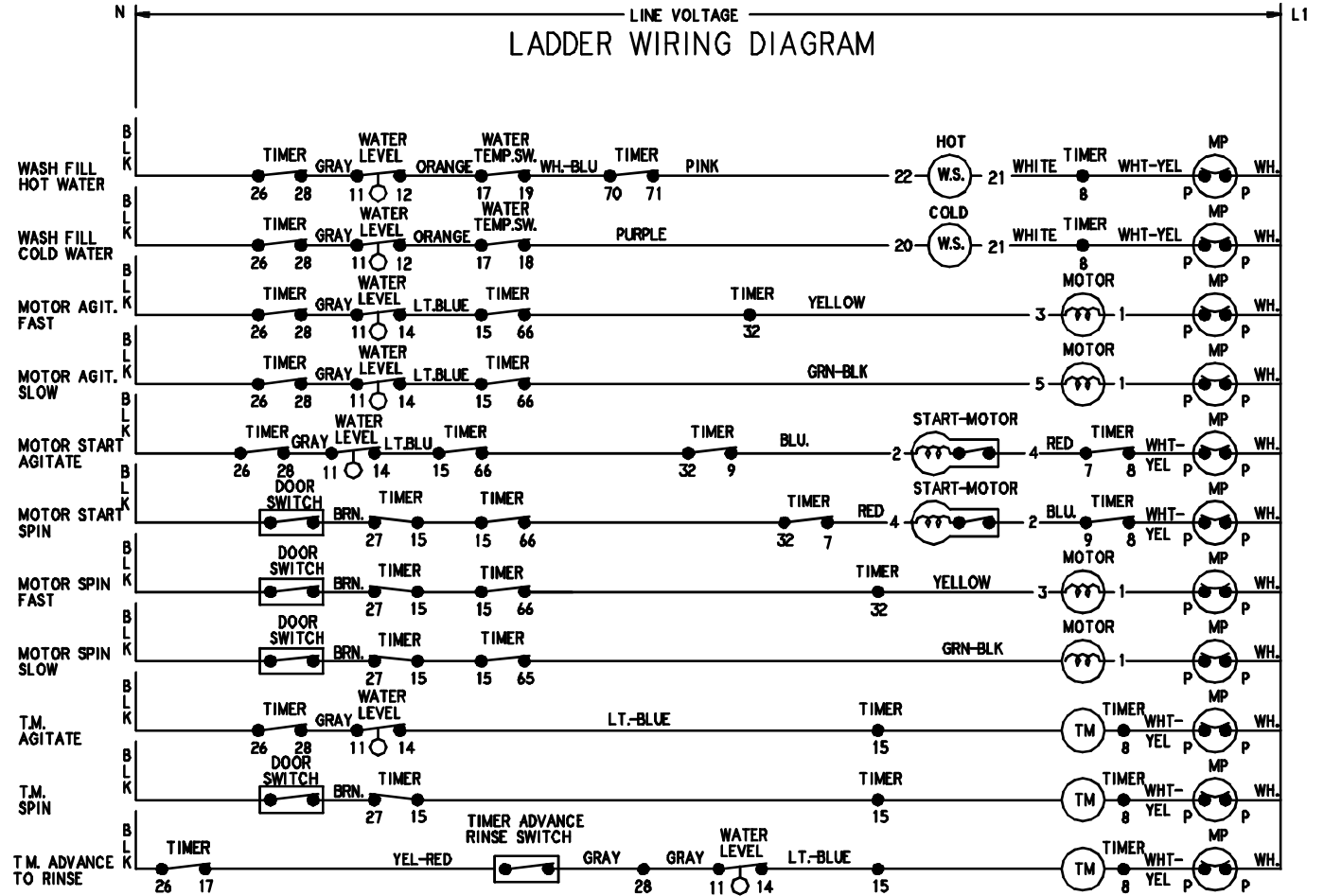

16023083

# WIRING INFORMATION

PAVT244

## CONNECTION DIAGRAM

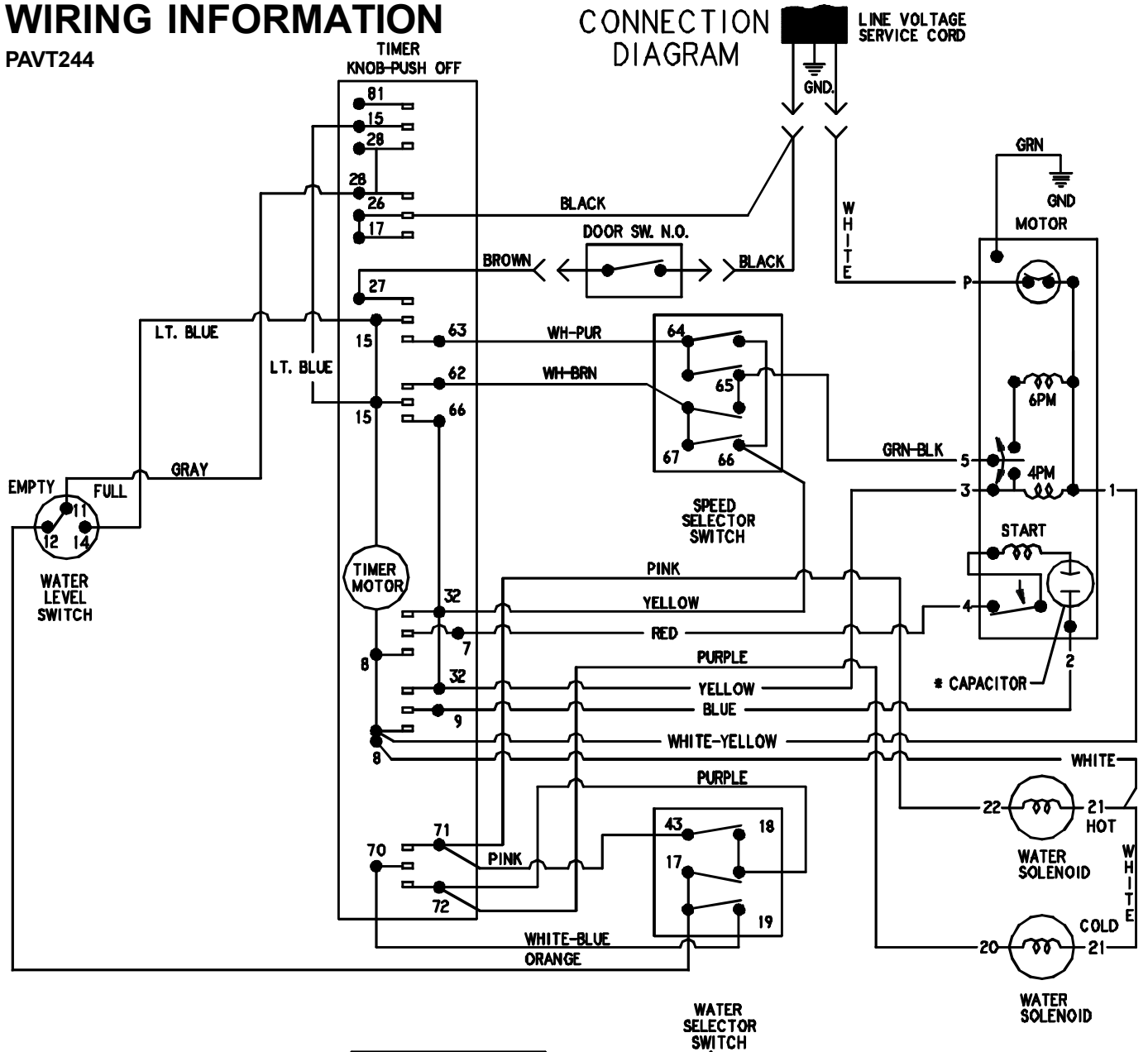

SPEED SELECTOR SWITCH		
WASH SPEEDS		
POSITION	CIRCUIT	
N-N	64-66 67-66	
N-S	66-64 65-67	
S-S	64-65 67-65	

SPEED SELECTOR SWITCH		
WASH SPEEDS		
POSITION	CIRCUIT	
N-N	64-66 67-66	
N-S	66-64 65-67	
S-S	64-65 67-65	

### SWITCH AND TIMER SEQUENCE

TO CHANGE TIMER POSITION PUSH KNOB IN AND TURN CLOCKWISE (ALL TIMER CONTACTS WILL OPEN)

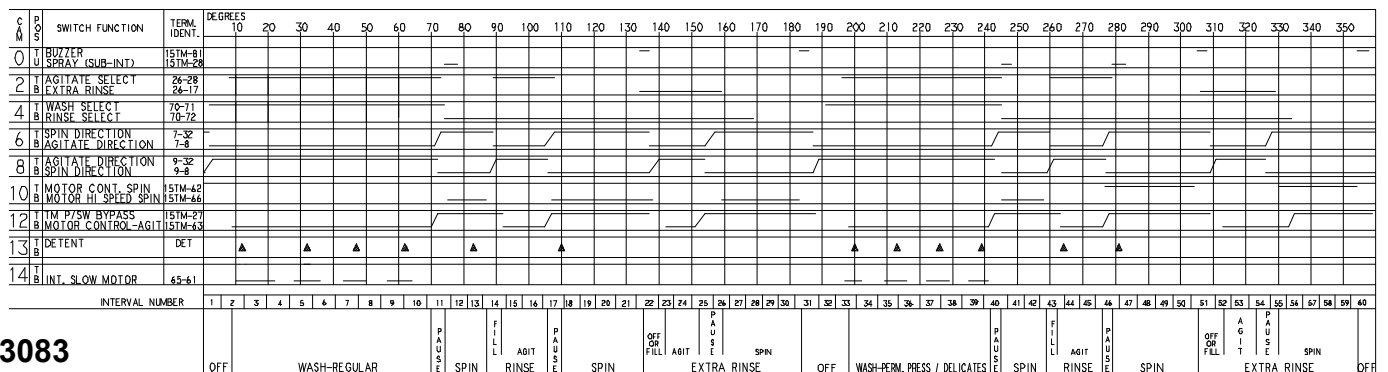

16023083

# WIRING INFORMATION

PAVT244

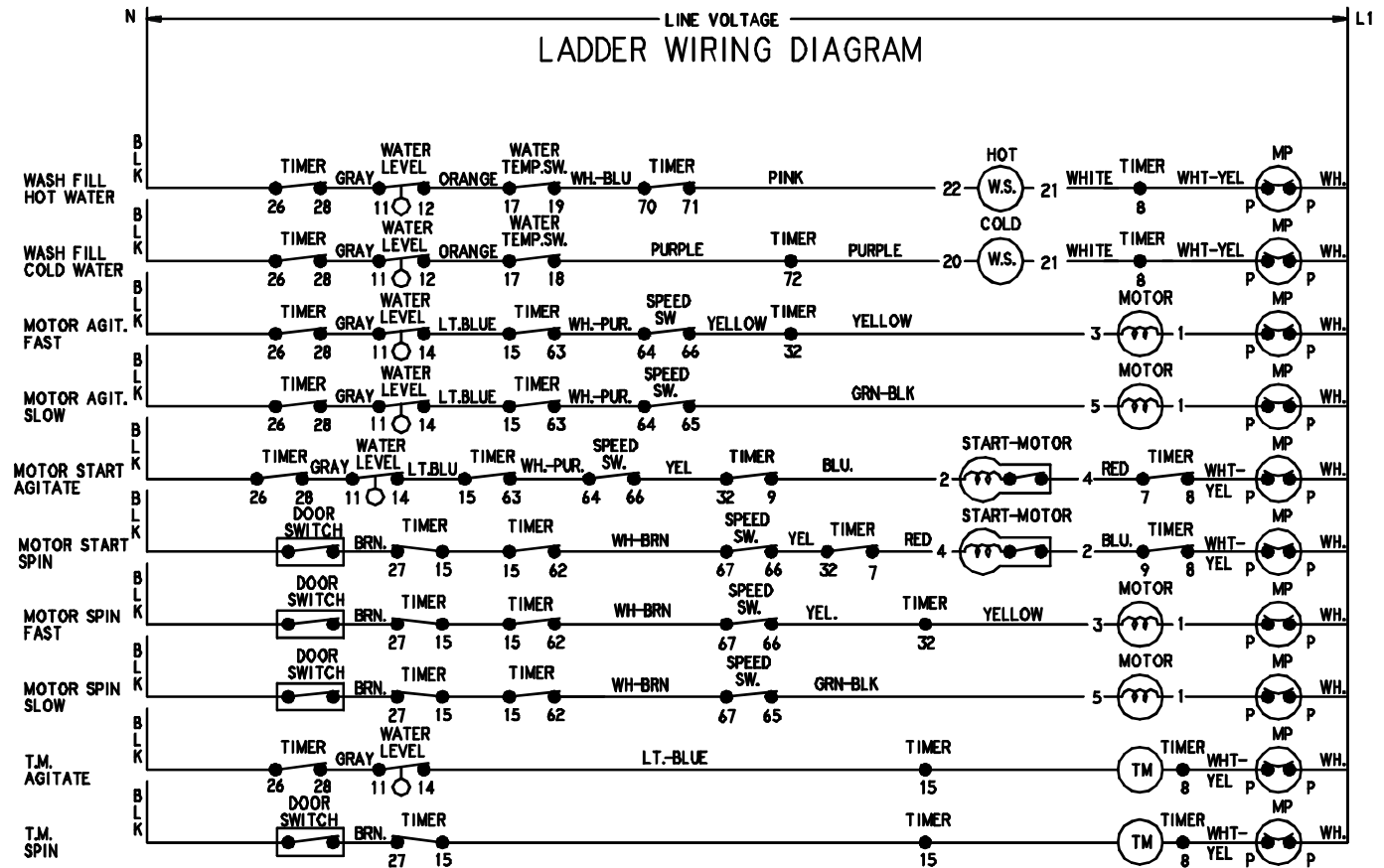

\* CAPACITOR USED WITH ALTERNATE CAPACITOR START MOTOR.

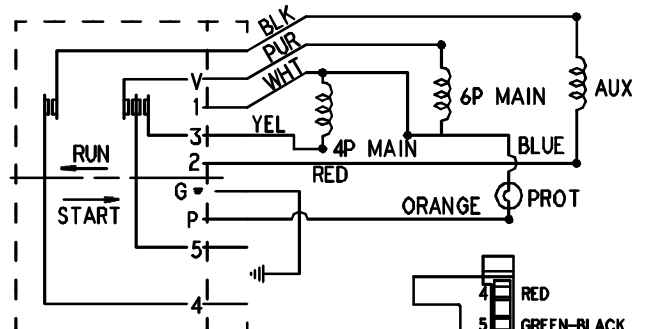
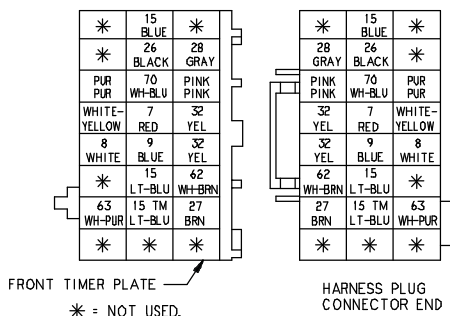

SCHMATIC  
EMERSON

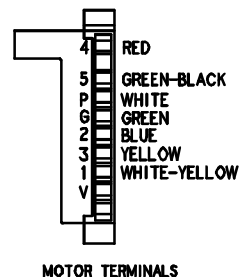

16023083

# WIRING INFORMATION

PAVT234, HAV2360, MAV2200

## CONNECTION DIAGRAM

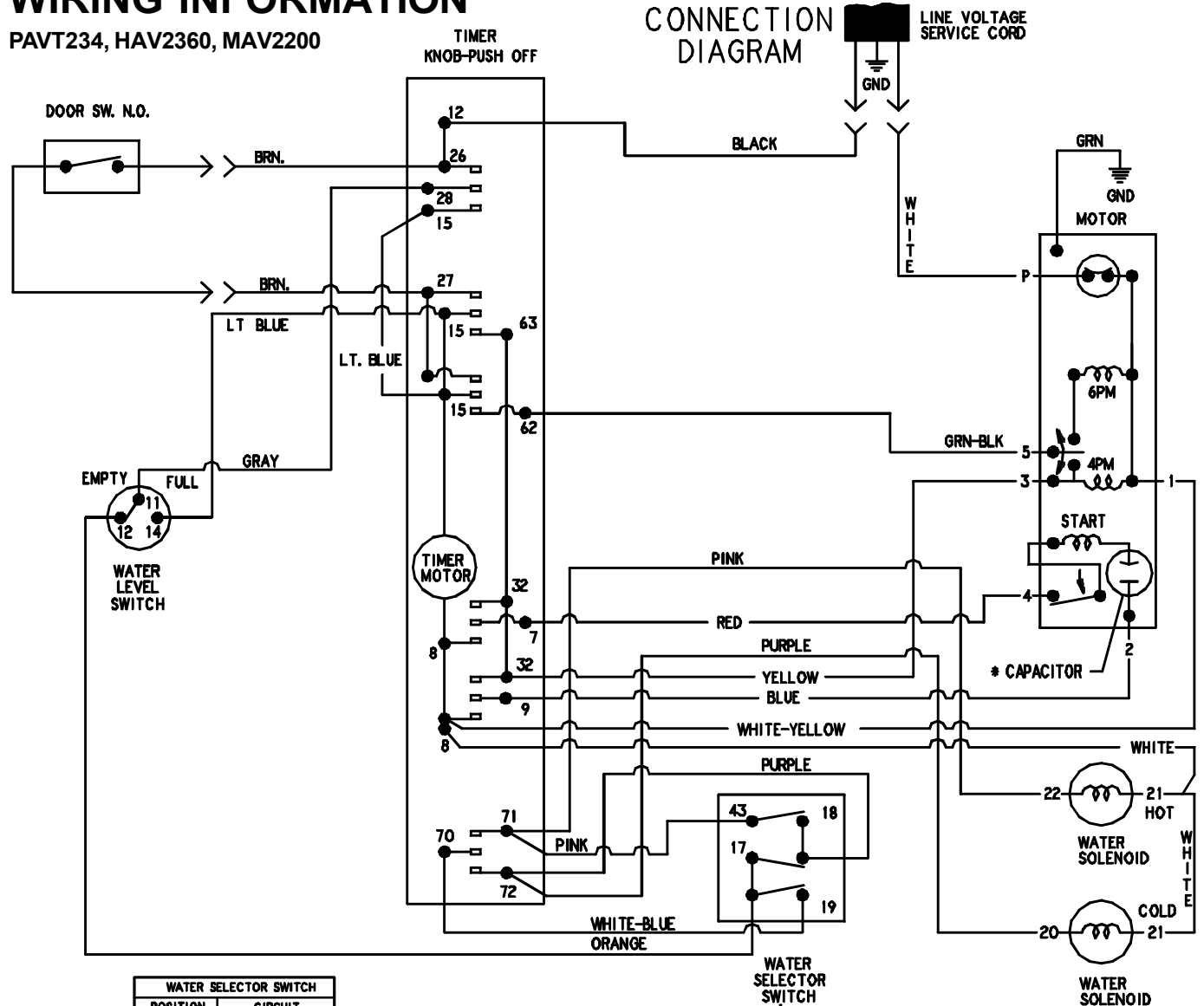

WATER SELECTOR SWITCH	
POSITION	CIRCUIT
H-C	17-19
W-W	17-18-19-43
W-C	17-18-19
C-C	17-18

### SWITCH AND TIMER SEQUENCE

TO CHANGE TIMER POSITION PUSH KNOB IN AND TURN CLOCKWISE (ALL TIMER CONTACTS WILL OPEN)

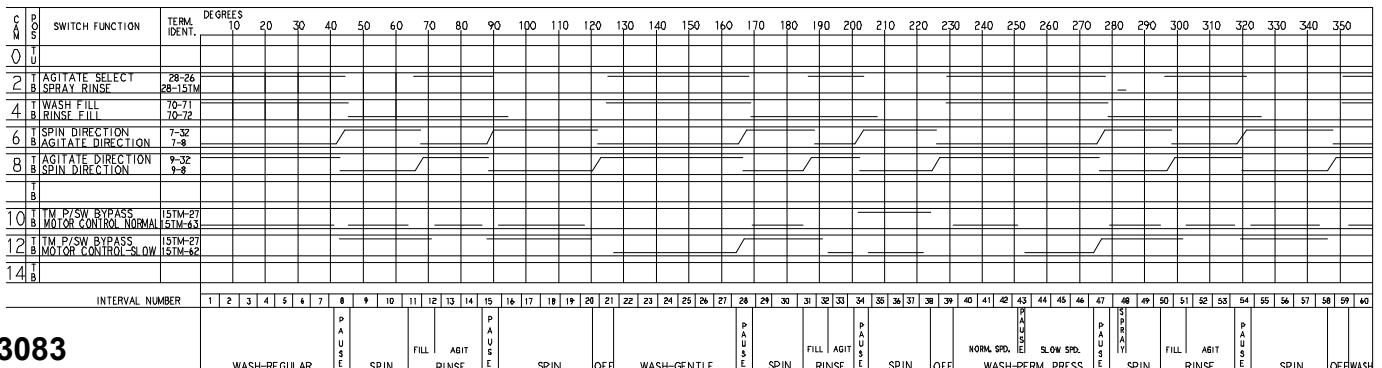

16023083

# WIRING INFORMATION

PAVT234, HAV2360, MAV2200

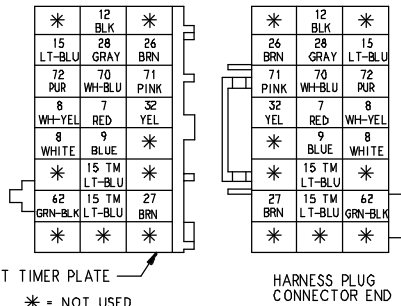
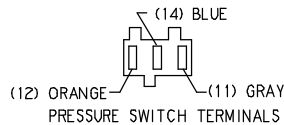
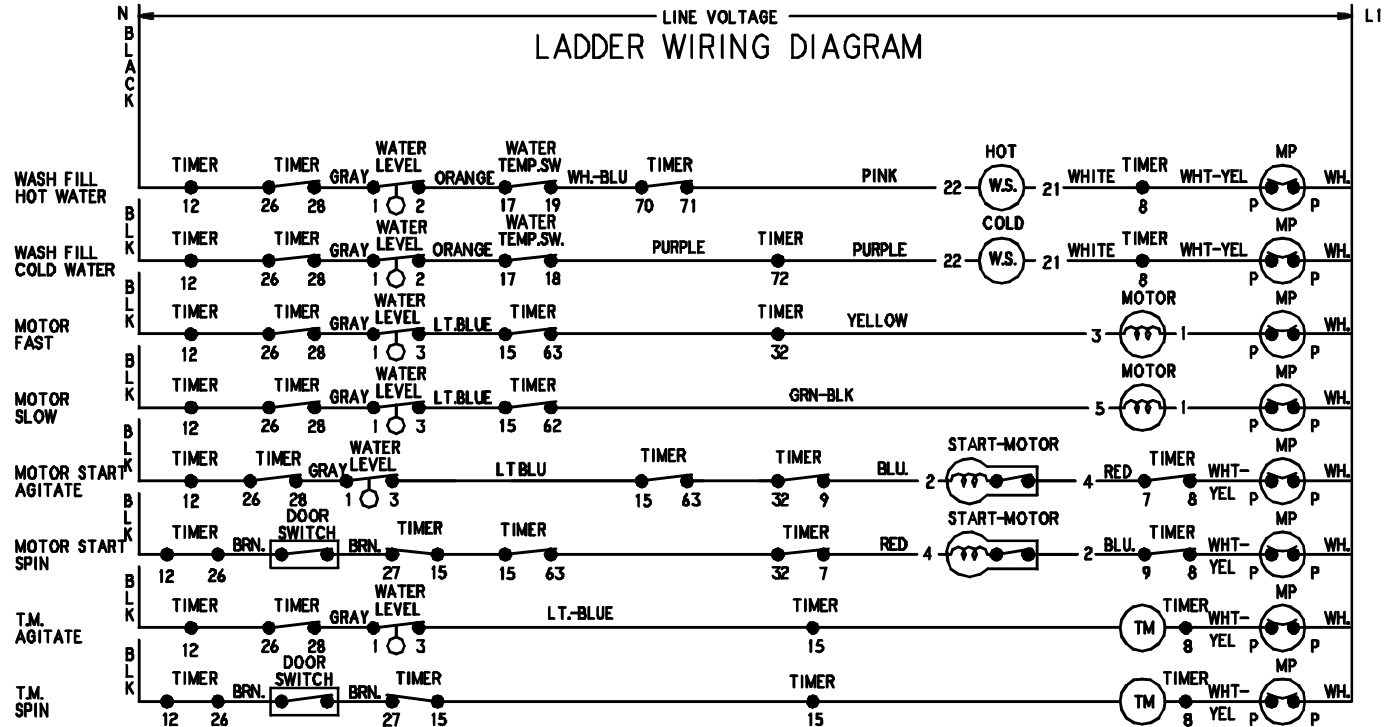

\* CAPACITOR USED WITH ALTERNATE CAPACITOR START MOTOR.

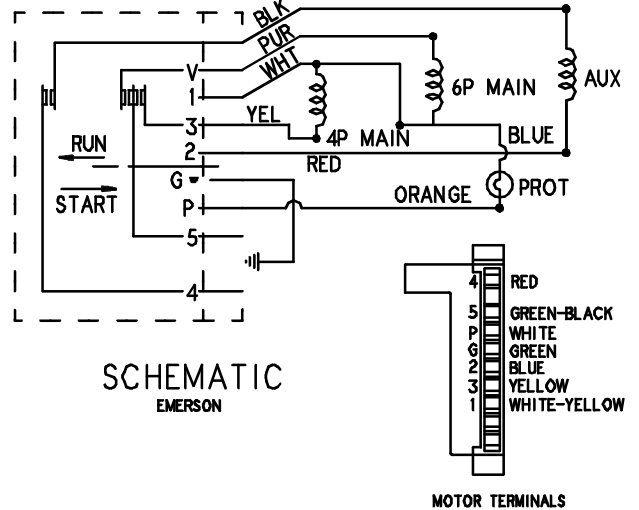





# WIRING INFORMATION

HAV2557/2558

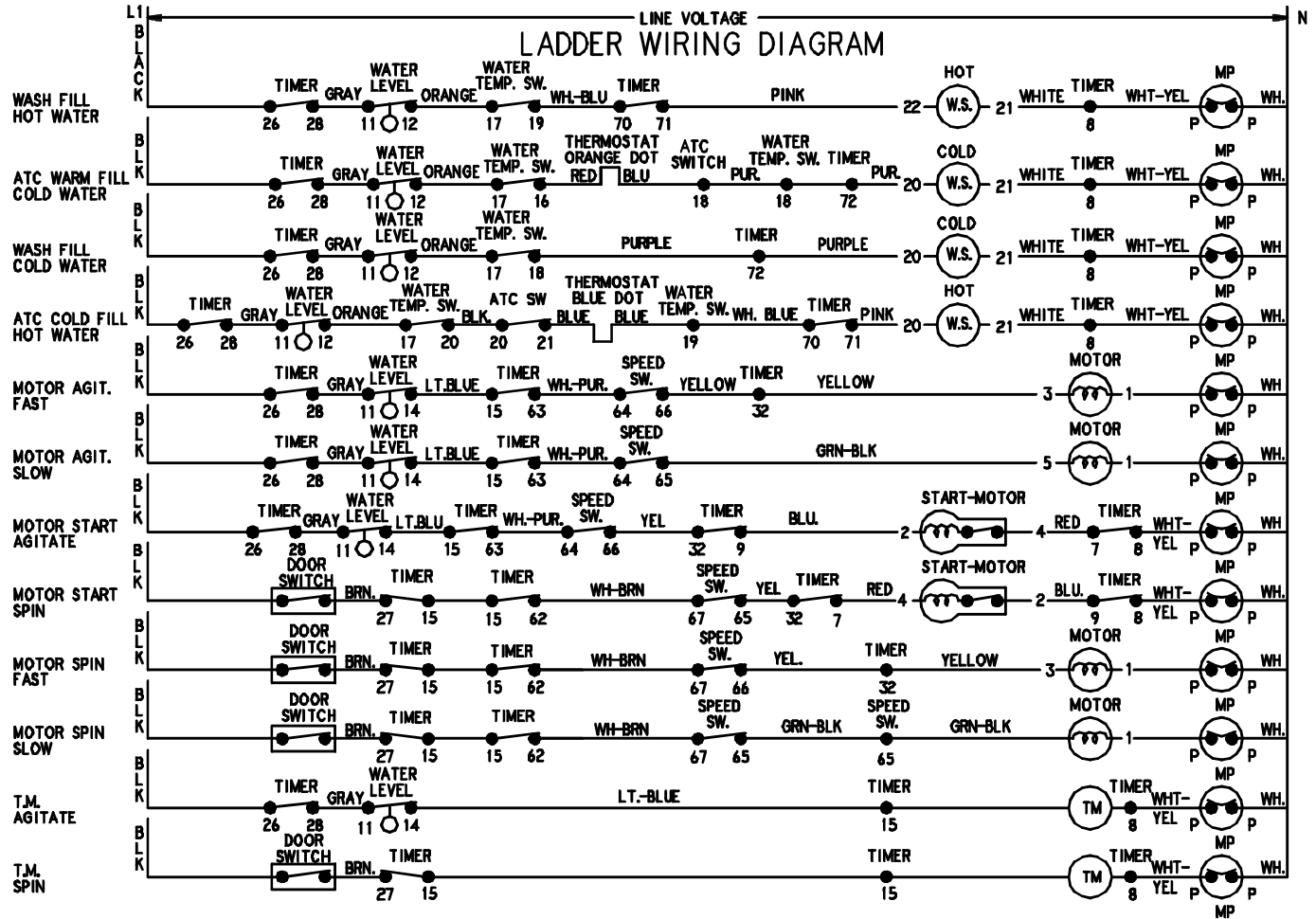

### Function of ATC

- ATC Cold Fill-** The ATC cold fill toggles from cold to warm in order to boost cold wash water temp to approximately 75 degrees minimum.
- ATC Warm Fill-** The ATC warm fill toggles from hot to warm in order to boost the warm water temperature to approximately 95 degrees minimum.

\* NOTE: ATC does not function for rinse

ATC Connector  
Terminals

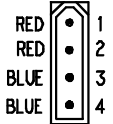

Water temperature	Wire Color	Circuit
<60 degrees	RD to RD	open
<60 degrees	BU to BU	closed
>110 degrees	RD to RD	closed
>110 degrees	BU to BU	open

To properly test ATC thermostats follow the steps below:

- IMPORTANT:** To protect meter all continuity checks must be made on the connector end going to thermostats.
- Step 1. Disconnect 4-wire plug connector located in background coming from water flume thermostats.
  - Step 2. Set water temperature selection for cold water fill and allow washer to fill for 2 minutes. Confirm water temperature entering washer is < 60 degrees and make continuity checks per table.
  - Step 3. Set water temperature selection for hot water fill and allow washer to fill for 2 minutes. Confirm water temperature entering washer is >110 degrees and make continuity checks per table.
  - Step 4. If results of continuity checks do not correspond to table and all wiring is proper, replace ATC flume thermostat accordingly.

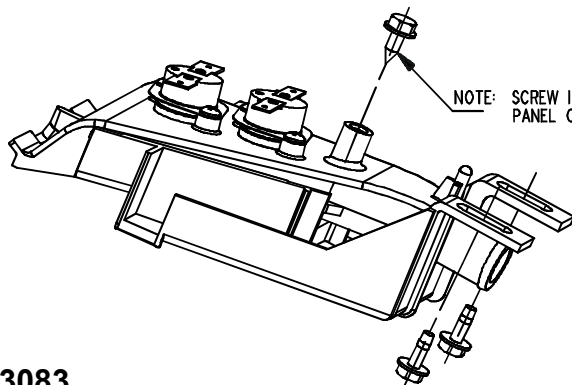

16023083

# WIRING INFORMATION

HAV3460

TIMER  
KNOB-PUSH OFF

## CONNECTION DIAGRAM

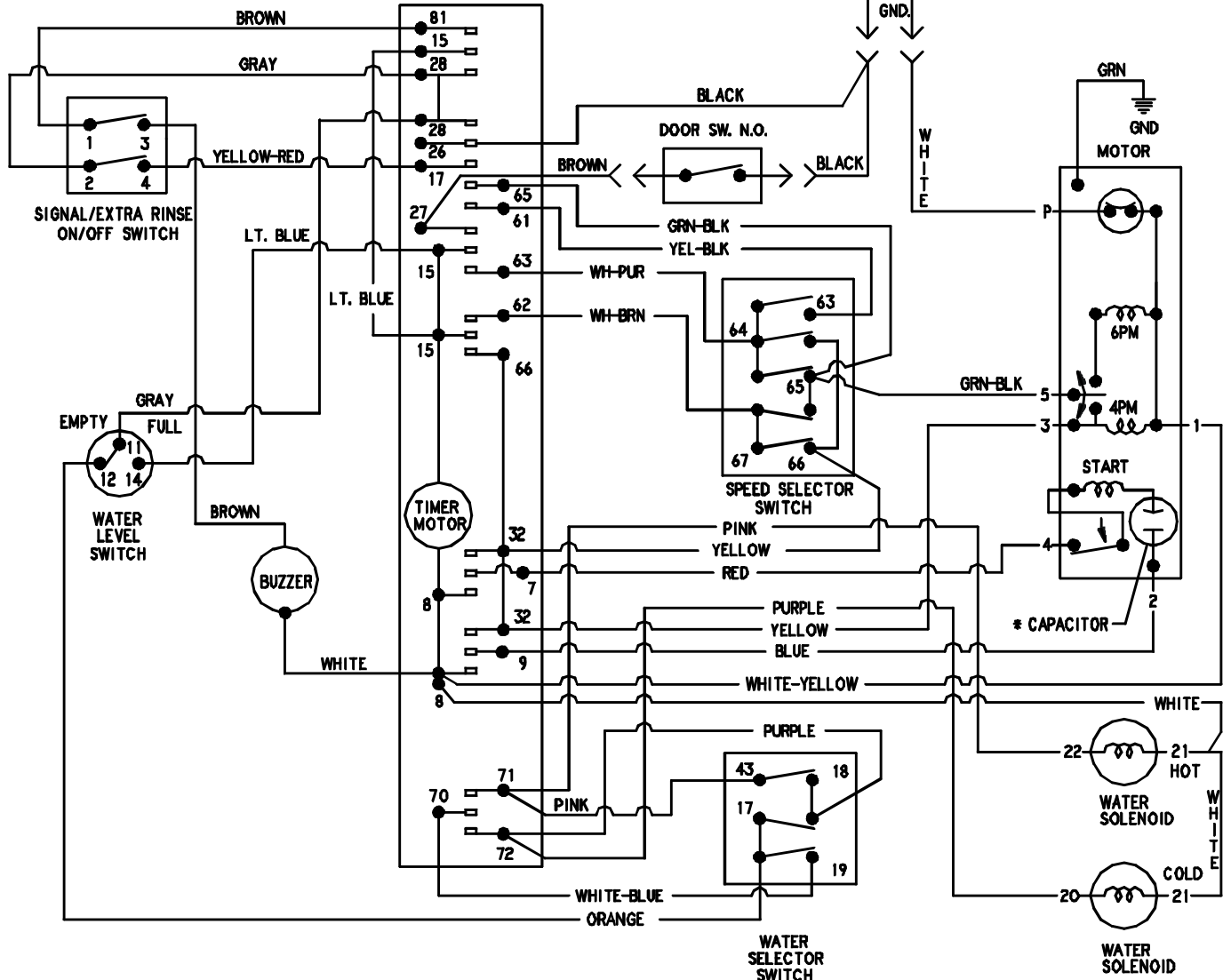
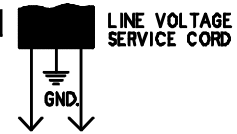

SIGNAL/EXTRA RINSE CONTROL SWITCH	
POSITION	CIRCUIT
EXTRA RINSE	2-4
SIGNAL	1-3
EXTRA RINSE SIGNAL	1-3 2-4
OFF	—

SPEED SELECTOR SWITCH	
WASH SPEEDS	
POSITION	CIRCUIT
H-N	64-66 67-66
N-S	64-66 67-65
S-S	65-64-67
X-S-S	64-63 65-67

WATER SELECTOR SWITCH	
POSITION	CIRCUIT
H-C	17-19
W-W	17-18-19-43
W-C	17-18-19
C-C	17-18

### SWITCH AND TIMER SEQUENCE

TO CHANGE TIMER POSITION PUSH KNOB IN AND TURN CLOCKWISE (ALL TIMER CONTACTS WILL OPEN)

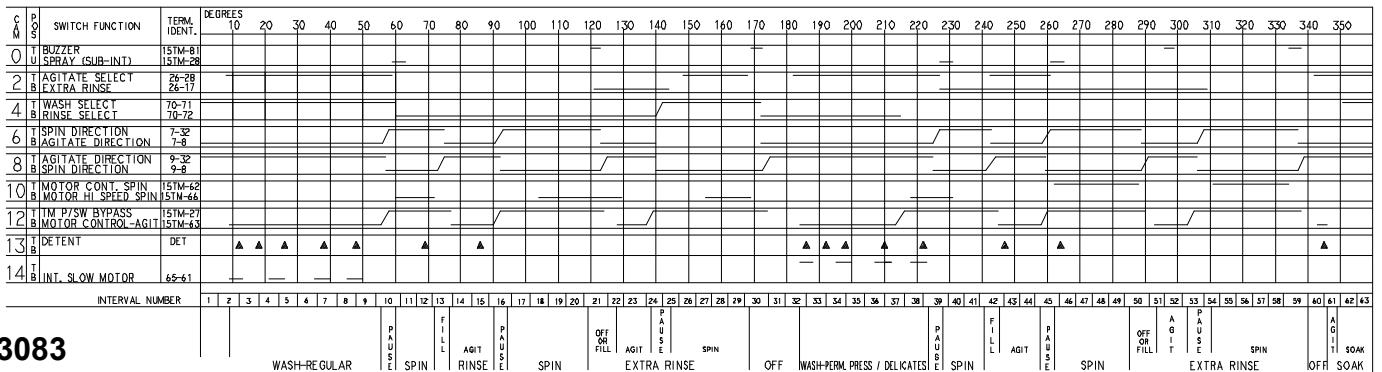

16023083

# WIRING INFORMATION

HAV3460

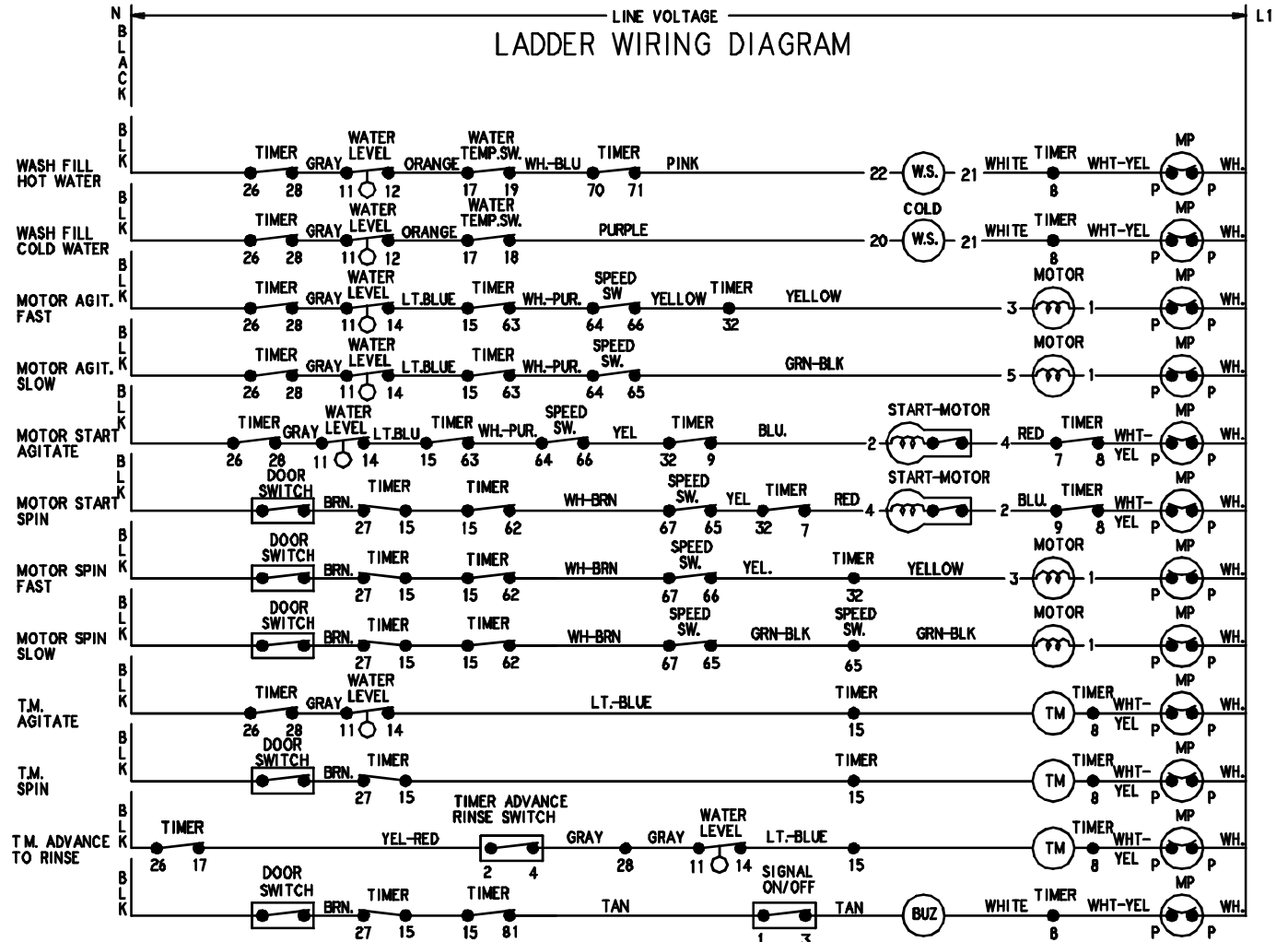

\* CAPACITOR USED WITH ALTERNATE CAPACITOR START MOTOR.

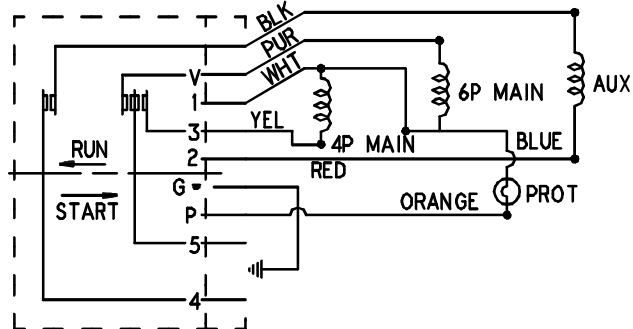
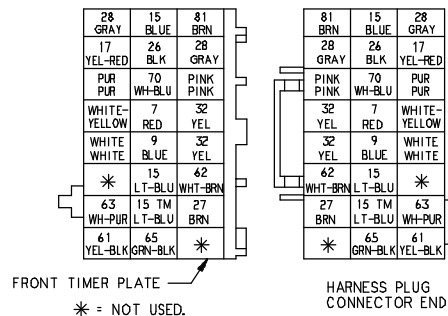

SCHEMATIC  
EMERSON

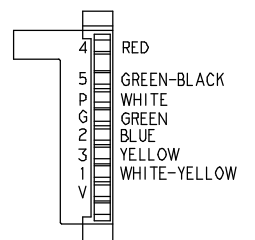

MOTOR TERMINALS

# WIRING INFORMATION

PAVT444, HAV4657

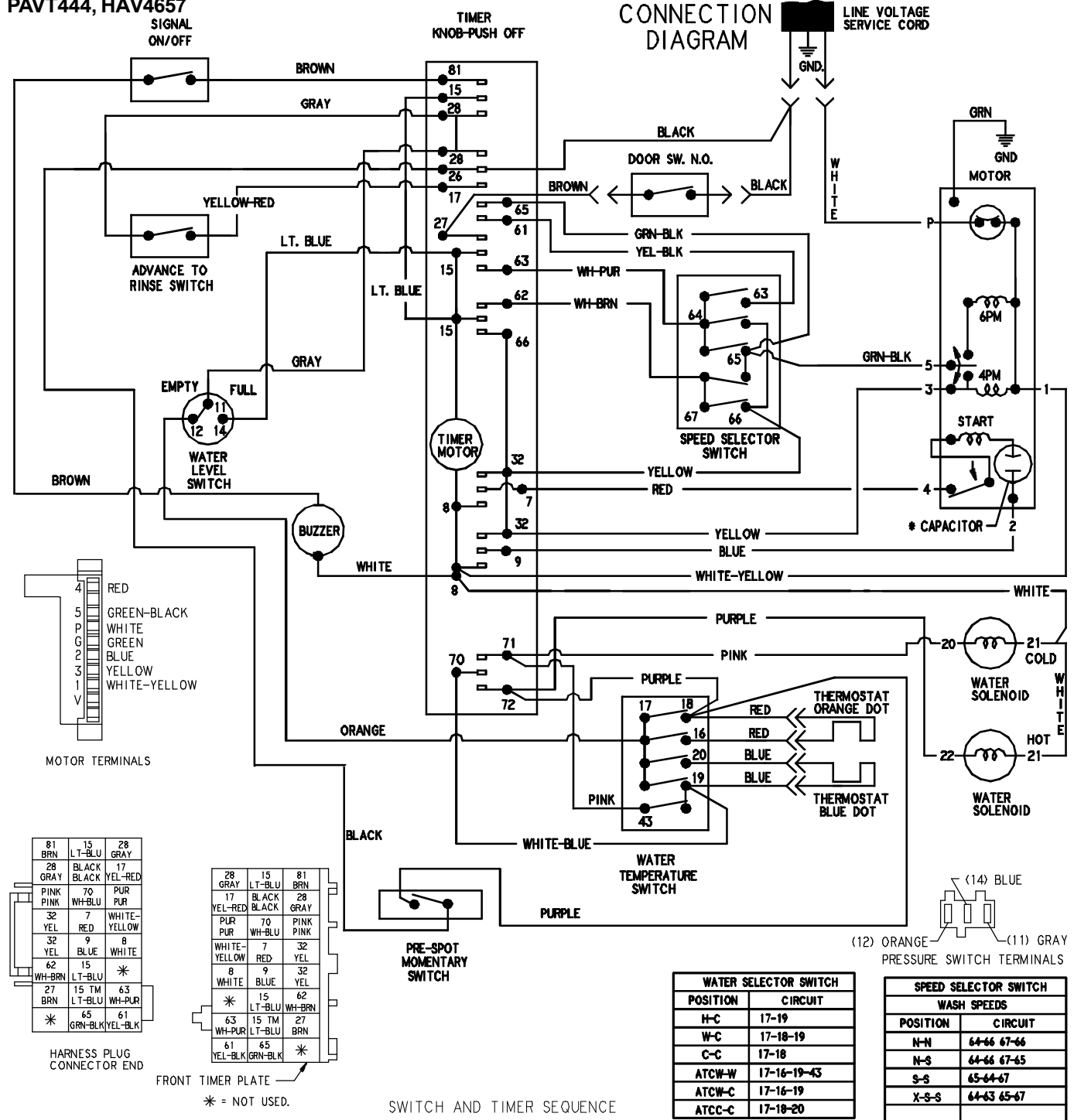

16023083

# WIRING INFORMATION

PAVT444, HAV4657

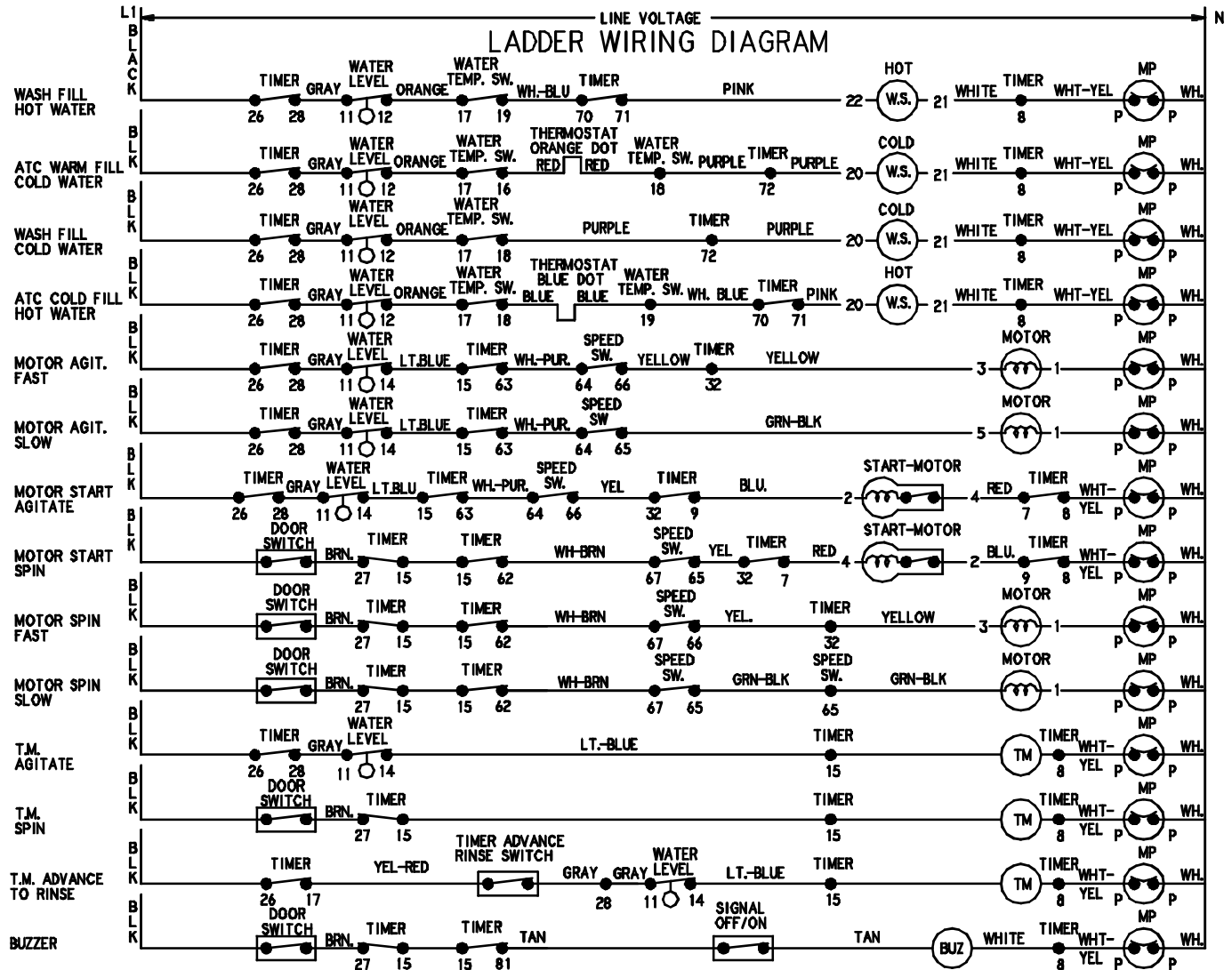

### Function of ATC

- ATC Cold Fill-** The ATC cold fill toggles from cold to warm in order to boost cold wash water temp to approximately 75 degrees minimum.
- ATC Warm Fill-** The ATC warm fill toggles from hot to warm in order to boost the warm water temperature to approximately 95 degrees minimum.

\* NOTE: ATC does not function for rinse

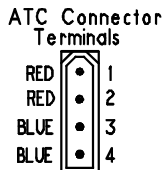

Water temperature	Wire Color	Circuit
<60 degrees	RD to RD	open
<60 degrees	BU to BU	closed
>110 degrees	RD to RD	closed
>110 degrees	BU to BU	open

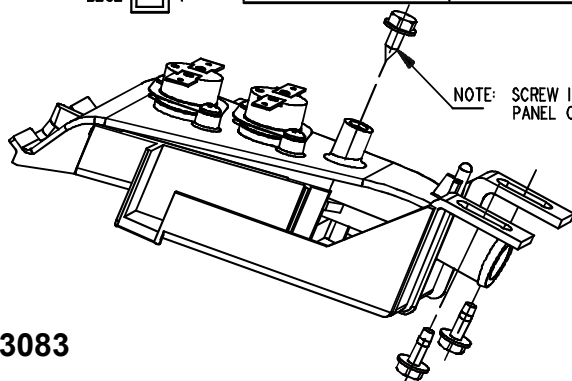

### To properly test ATC thermostats follow the steps below:

- \*IMPORTANT: To protect meter all continuity checks must be made on the connector end going to thermostats.
- Step 1. Disconnect 4-wire plug connector located in background coming from water flume thermostats.
- Step 2. Set water temperature selection for cold water fill and allow washer to fill for 2 minutes. Confirm water temperature entering washer is < 60 degrees and make continuity checks per table.
- Step 3. Set water temperature selection for hot water fill and allow washer to fill for 2 minutes. Confirm water temperature entering washer is > 110 degrees and make continuity checks per table.
- Step 4. If results of continuity checks do not correspond to table and all wiring is proper, replace ATC flume thermostat accordingly.

\* CAPACITOR USED WITH ALTERNATE CAPACITOR START MOTOR.

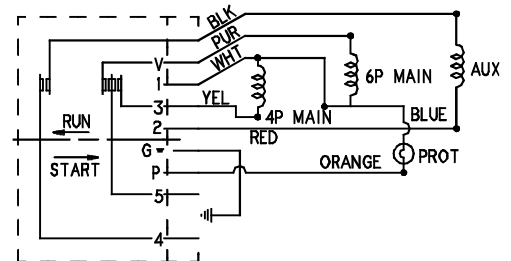

SCHEMATIC  
EMERSON



---

## SECTION 9. TROUBLESHOOTING

<b>QUICK CHECK SERVICE GUIDE</b>	
<b>SERVICE PROBLEM</b>	<b>QUICK CHECK NO.</b>
Basket Revolves During Agitation	3
Clothes Wet After Spin	8
Excessive Vibration	6
Fills - Will Not Agitate	2
Fill Water Temperature Incorrect	1
No Timer Advance	4
Machine Does Not Shut Off	4
No Rinse Fill	1
Noisy In Spin	6
Noisy In Agitation	6
Spin Speed Too Slow	5
Water Leaks	9
Will Not Fill	1
Will Not Pump Out	7
Will Not Spin	5

**QUICK CHECK 1 - FILL WATER TEMPERATURE INCORRECT/ NO RINSE FILL/WILL NOT FILL**

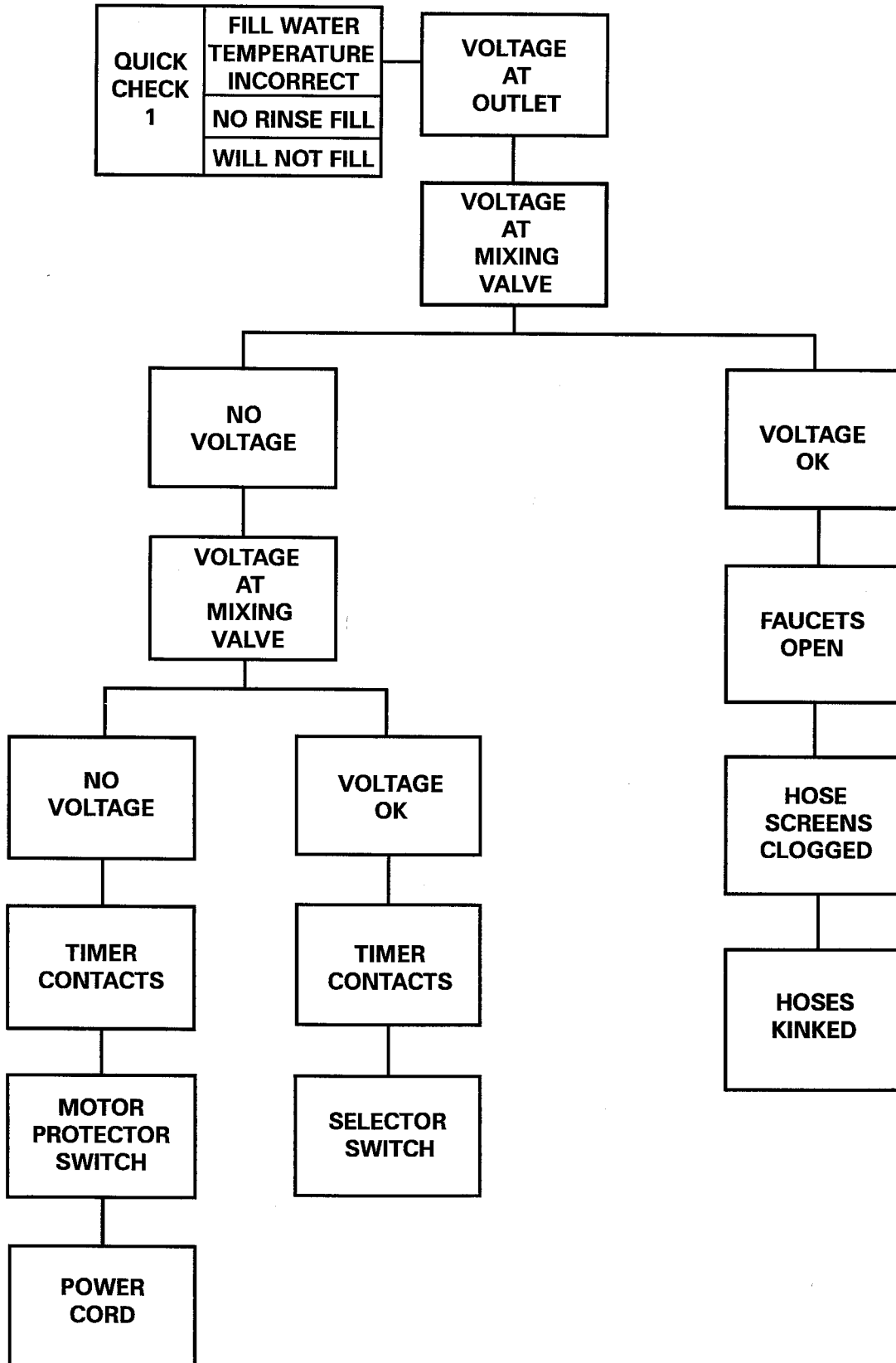



**QUICK CHECK 2 - FILLS - WILL NOT AGITATE**

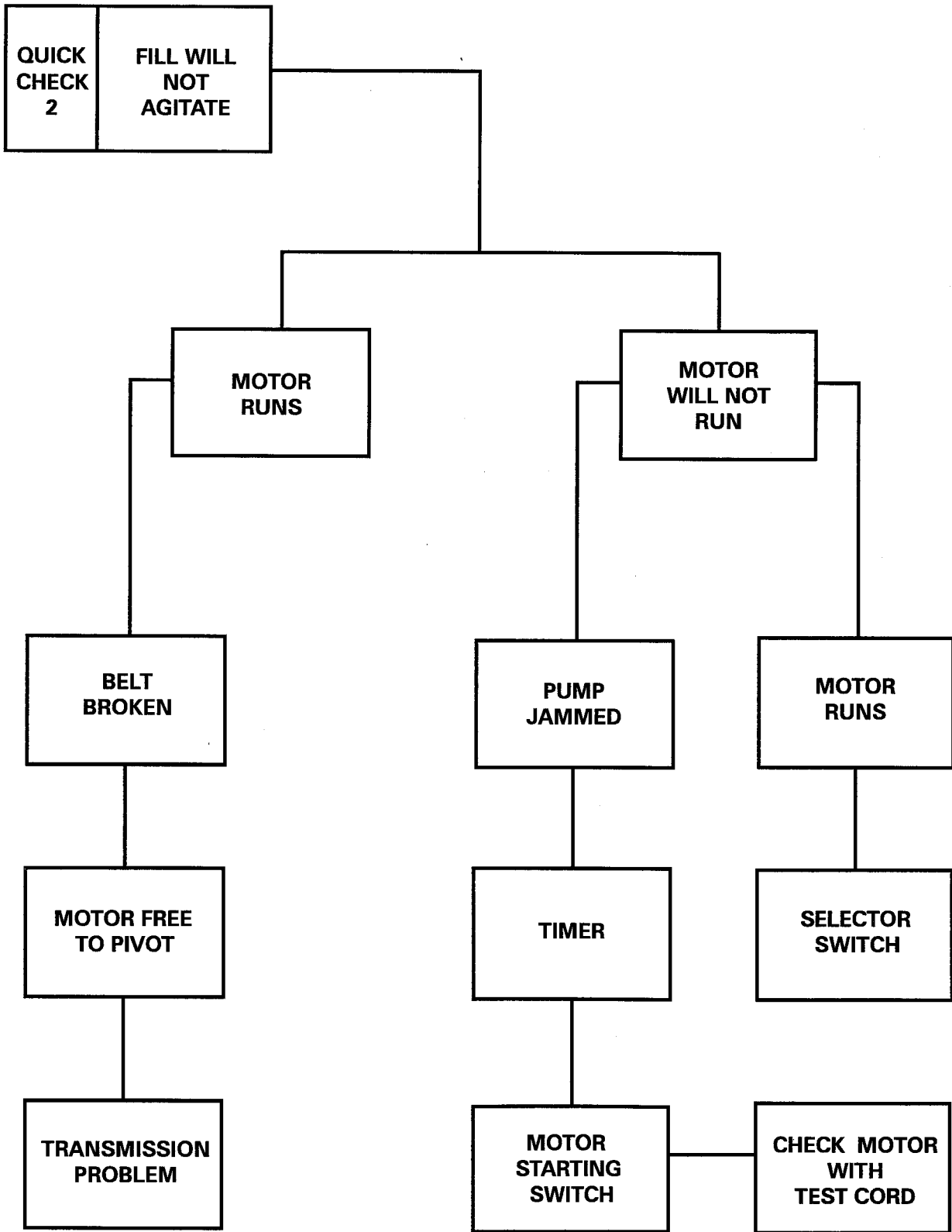

---

**QUICK CHECK 3 - BASKET REVOLVES DURING AGITATION**

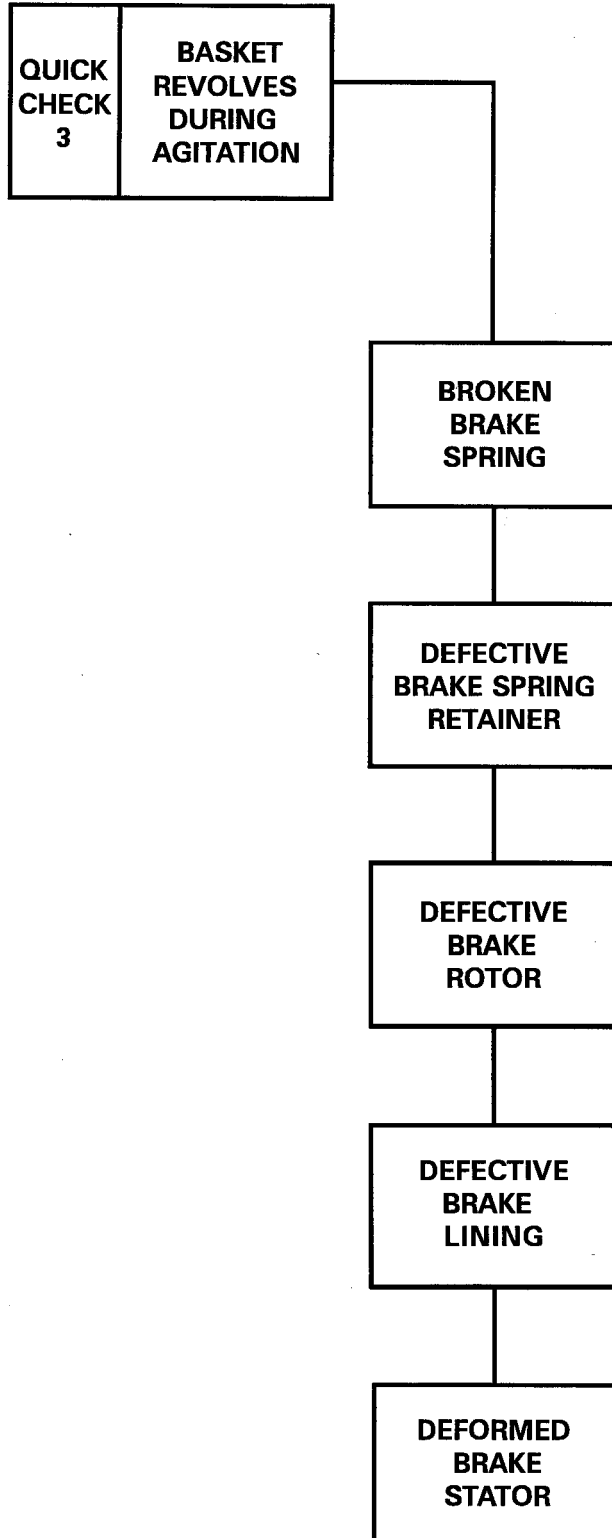

**QUICK CHECK 4 - NO TIMER ADVANCE; MACHINE DOES NOT SHUT OFF**

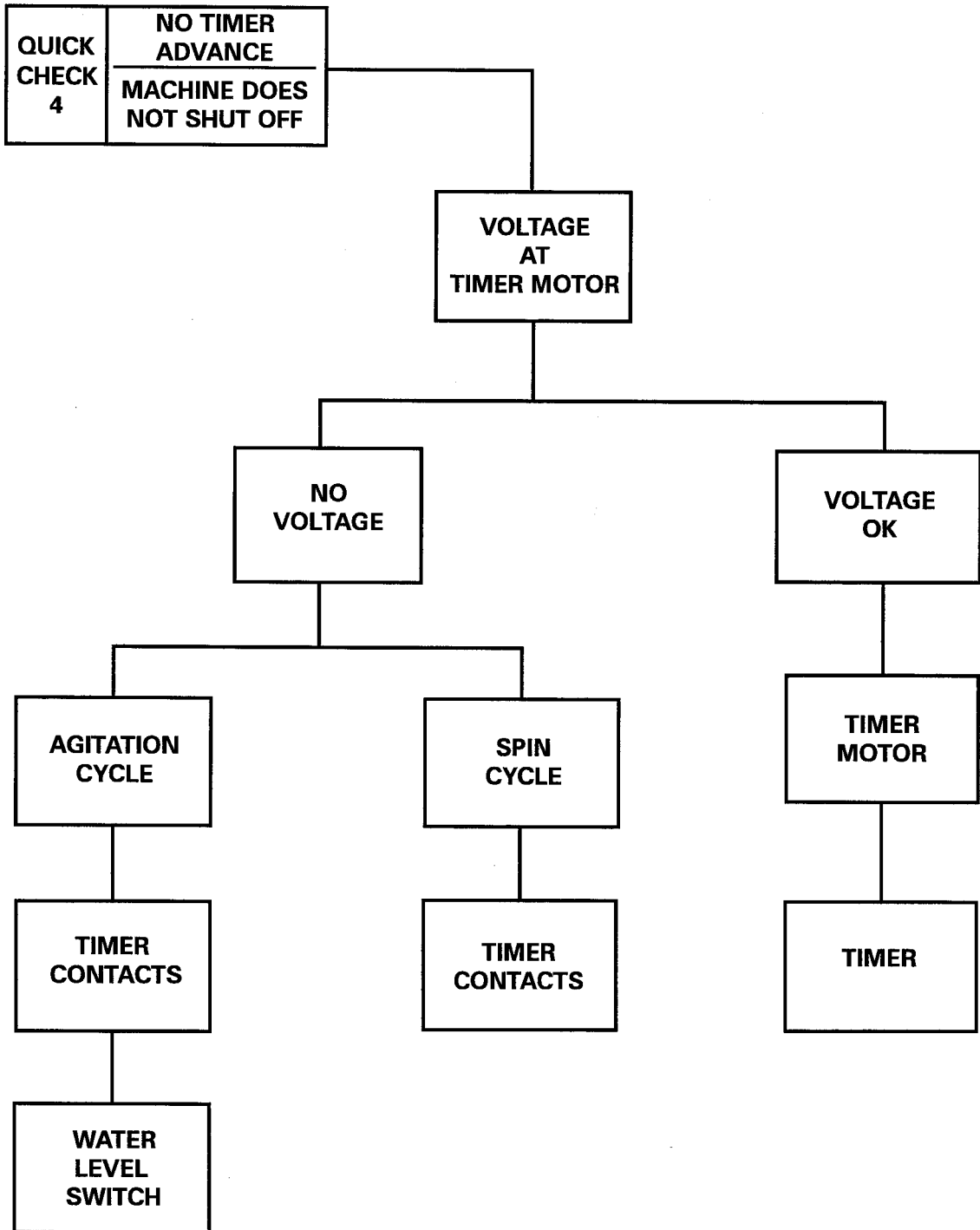

# QUICK CHECK 5 - SPIN SPEED TOO SLOW; WILL NOT SPIN

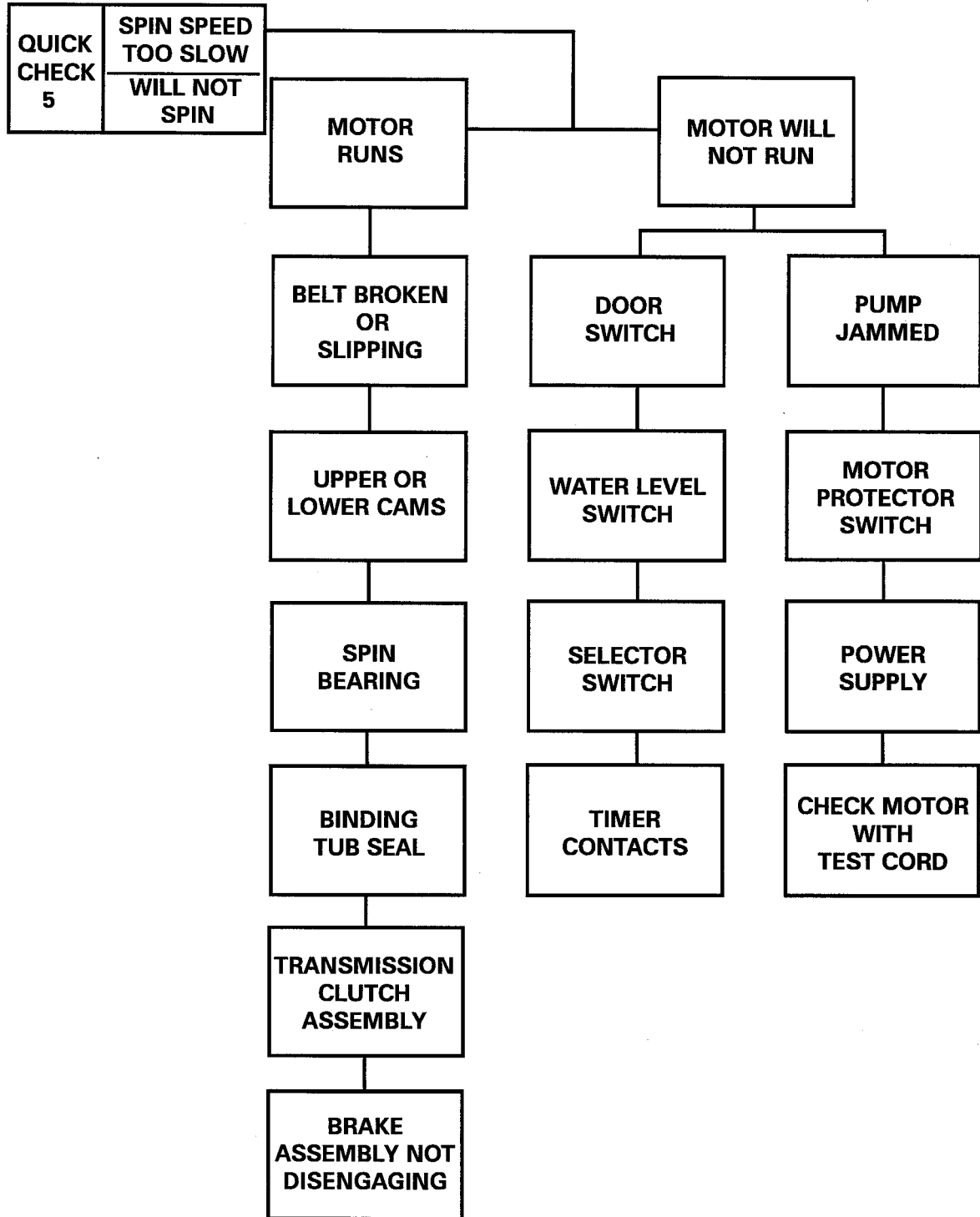

**QUICK CHECK 6 - EXCESSIVE VIBRATION/ NOISY IN SPIN/ NOISY IN AGITATION**

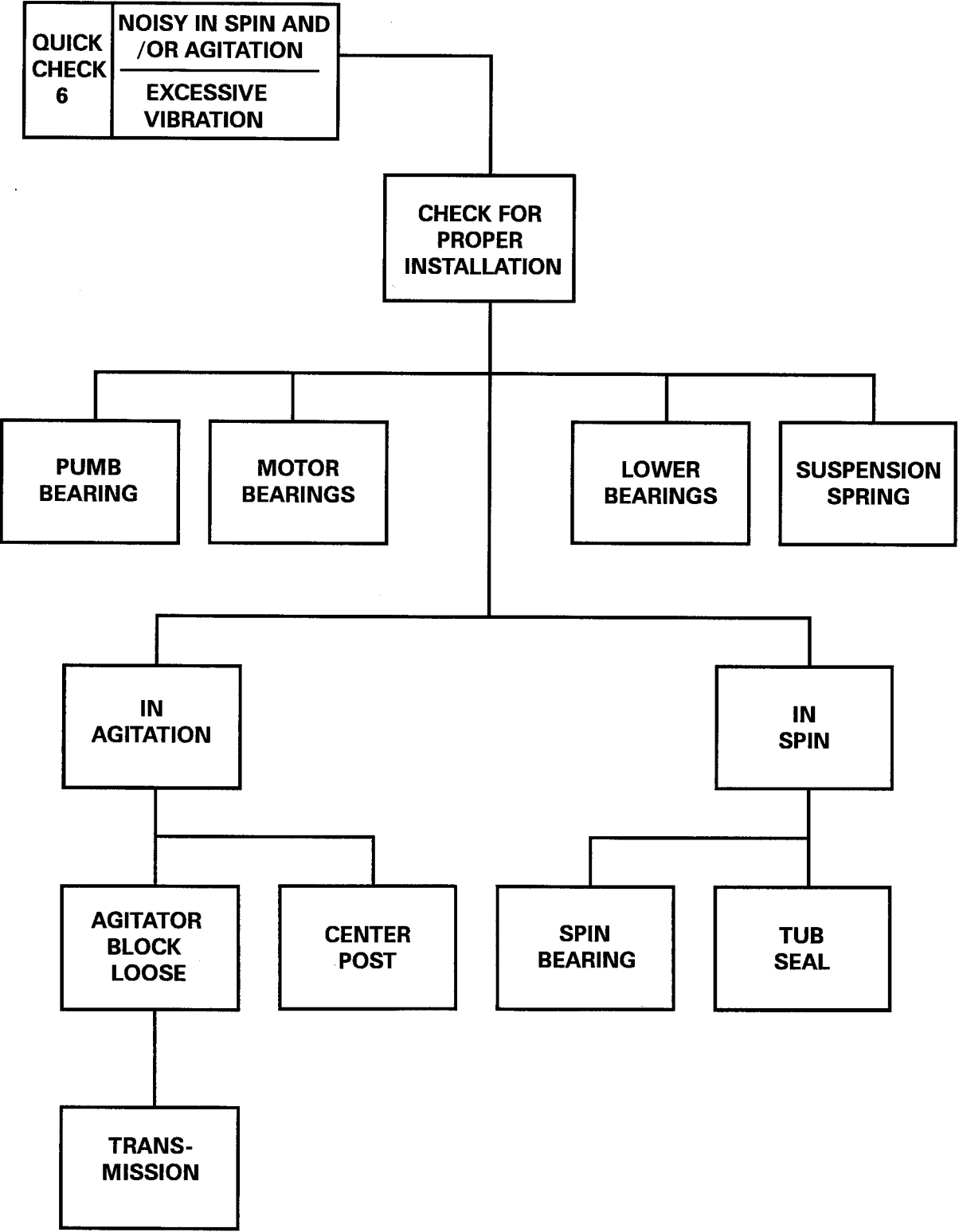

## QUICK CHECK 8 - CLOTHES WET AFTER SPIN

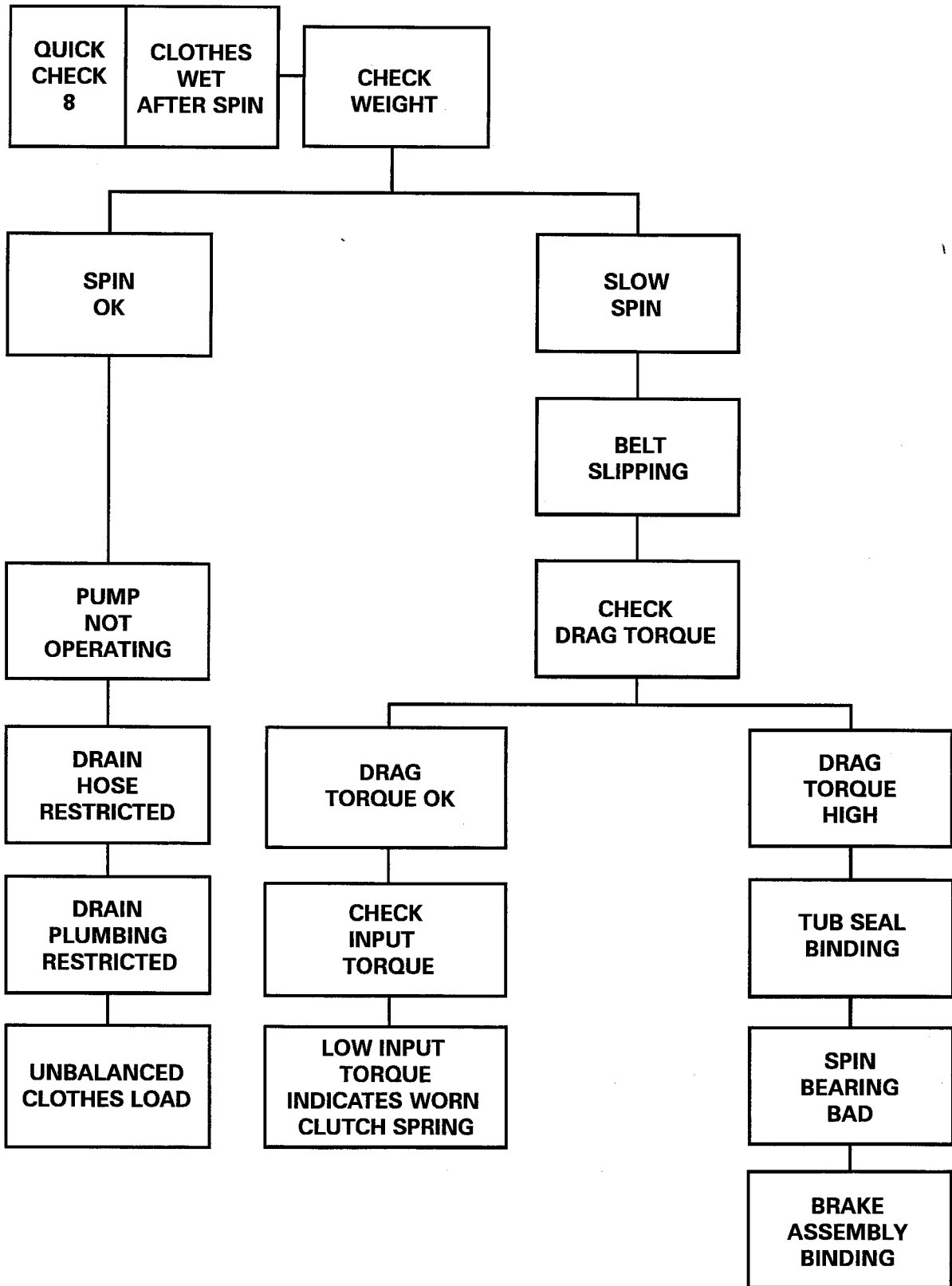

---

## QUICK CHECK 9 - WATER LEAK

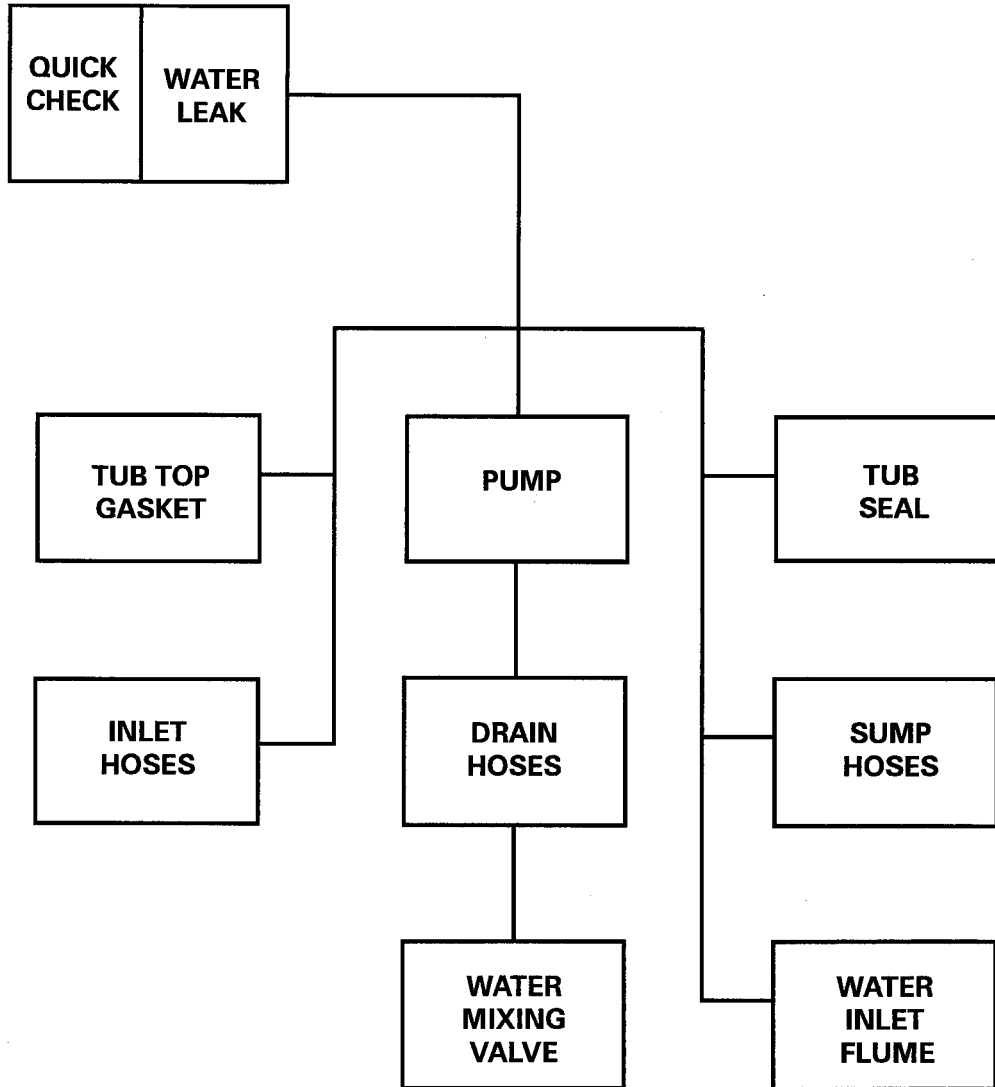

# TEMPERATURE CONTROL BOARD

**Model: PAV5000**

The temperature control board receives information from the water temperature switch about the user's water selections. The thermistor located in the water valve, provides inputs to the board, as it detects the incoming water temperature. This information combined with the selections on the temperature control switch determine the output signals to the water valve. The target cold temperature is 75° F, ± 5° F. The target warm temperature is 95° F, ± 5° F. The temperature control system is intended to warm wash fills when necessary to the target temperature. It will not cool a fill when the inlet temperature exceeds the minimum target temperature.

The analog board monitors the water temperature and will turn the valves ON and OFF to maintain proper water temperature. When the water temperature is set on WARM, both valves are on. The longer the valve is ON, the lower the water temperature will drop in the water lines. As the temperature drops the automatic temperature control will cycle the water valve to maintain the proper water temperature. Rinse fills are not temperature controlled unless warm rinse is selected.

The analog automatic temperature control (ATC) table depicts the philosophy of how the automatic temperature control board operates. The thermistor temp represents the temperature sensed by the thermistor in the water valve. The outputs are indicative of the board sending voltage to the water valve solenoids.

**Note:** With the temperature control selector in the ON position. The only combinations where the temperature control board is active (BOLD) are warm and cold.

When cold is selected and the temperature sensed by the thermistor is too low at the valve, the hot valve will be activated.

When warm is selected and the temperature sensed by the thermistor is too cool, the cold valve will be shut off.

**Analog Automatic Temperature Control (ATC) Table**

Water Temp Selections	ATC Selector	Thermistor Temp	Hot Valve Output	Cold Valve Output
Hot	Off	Low	On	Off
Warm	Off	Low	On	On
Cold	Off	Low	Off	On
Hot	Off	High	On	Off
Warm	Off	High	On	On
Cold	Off	High	Off	On
Hot	On	Low	On	Off
Warm	On	Low	On	<b>Off</b>
Cold	On	Low	<b>On</b>	On
Hot	On	High	On	Off
Warm	On	High	On	On
Cold	On	High	Off	On



# TEMPERATURE CONTROL BOARD

## Analog Temperature Board Tests

To test the temperature board for proper function, use the diagnostics chart below in conjunction with the 11 terminal pin connector and an ohm meter.

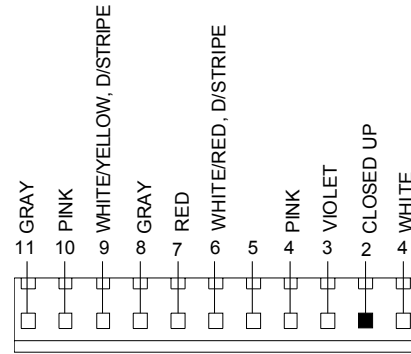

## Analog Temperature Control Board Diagnostics Chart

PIN	SOURCE	OUTPUT/INPUT	WIRE COLOR	MEASURE TO PIN #	VOLTS OHMS	CONDITIONS
1	Neutral	Input	WHITE	Line	120VAC	
2	Not Used					
3	Cold Valve	Output	VIOLET	1	120VAC	
4	Hot Valve	Output	PINK	1	120VAC	
6	Timer (12 T Contact)	Input	WHITE/RED, D/STRIPE	1	120VAC	Wash Cycle on Timer
7	TC Disable	Input	RED	6	OVDC 3- 24VDC	TC Option Deselected TC Option Selected
8	Thermistor	Input	GRAY	11	10K- 100K OHMS	Room Temperature
9	Temp Selector Switch Cold Wash	Input	WHITE/YELLOW, D/STRIPE	6 * **	OVDC	Warm or Cold Wash Selected
10	Temp Selector Switch Hot Wash	Input	PINK	6 * **	OVDC	Hot or Warm Wash Selected
11	Thermistor	Input	GRAY	8	10K- 100K OHMS	Room Temperature

\* Reference DC voltages to line 1.

\*\* Temperature only occurs during cold or warm wash fills.

