

Technical Bulletin

MAYTAG®

Type Policy Letter
ö Service Information

Attention Service Managers
ö Service and Parts Managers

Date: May 2004

No: TDL-0017B-B
ITDL-0014-B
Page 1 of 8
Supersedes TDL-0017A-B

Models Herrin/Atlantis platform washers PAV*, CAV*, MAV- PAV2300AWW, PAV2360AWW, PAV3240AWW, PAV3300AWW, PAV3360AWW, PAV4960AWW, PAV5000AWQ, PAV5000AWW, PAV5157AWW, PAV5158AWW, PAV5057AWW, PAV5058AWW, CAV2000AGW, CAV2000AJW, CAV2000AKW, CAV2000AWQ, CAV1000AWW, PAV2300AGW, PAV3300AGW, PAV3300AKW, PAV2200AGW, PAV2200AAW, PAV3200AGW, PAV3200AAW, MAV5736AWW, MAV5842AWW, MAV6357AWW, MAV6451AWQ, MAV6451AWW, MAV6548AWQ, MAV6548AWW, MAV6601AWQ, MAV6601AWW, MAV7346AWW, MAV7357AWQ, MAV7357AWW, MAV7358AWQ, MAV7358AWW, MAV7501EWW, MAV7551AWQ, MAV7551AWW, MAV7636AWQ, MAV7636AWW, MAV7642AWQ, MAV7642AWW, MAV7751AWQ, MAV7751AWW, MAV7757AWQ, MAV7757AWW, MAV7901AWQ, MAV7901AWW, MAV8751AWQ, MAV8751AWW, MAV8757AWQ, MAV8757AWW, MAV9501EWW, LNC6760A71, NAV3200AWW, NAV4200AGW, NAV4200AKW, HAV1200ARW, HAV1200AWQ, HAV1200AWW, HAV4200AKW, HAV4200ATW, HAV4200AWW, MAV6260AWW, MAV6451AGW, MAV7260AWW, MAV7260BWW, MAV8260AWQ, MAV8260AWW, MAV8551AGW, MAV8551AWQ, MAV8551AWW, MAV8601AWQ, MAV8601AWW, MAV9750AWQ, MAV9750AWW, MAVT634AWW, MAVT834AWQ, MAVT834AWW, MAV6357AWW, MAV7357AWW, MAV7357AWQ, MAV7358AWW, MAV7358AWQ, MAV7757AWW, MAV7757AWQ, MAV8757AWW, MAV8757AWQ

Brand
Maytag
Maytag Performa

Product
Laundry

Issue Transmission and Seal design change.

Warranty Standard manufacturing warranty applies.

Action A new transmission and seal were introduced in production starting with series 17 for Herrin platform washers, and series 16 for Atlantis. The transmission and seal are matched, and not interchangeable with older parts. The new seal creates a higher coefficient of friction and requires a transmission with a higher output torque. The attached instruction sheet illustrates installing a new seal on high torque transmission product.

Face Tub Seal Assembly used with the 21001536 Transmission.

NOTE: There are 2 seal parts, 1 in the plastic housing and 1 in the aluminum spinner hub.

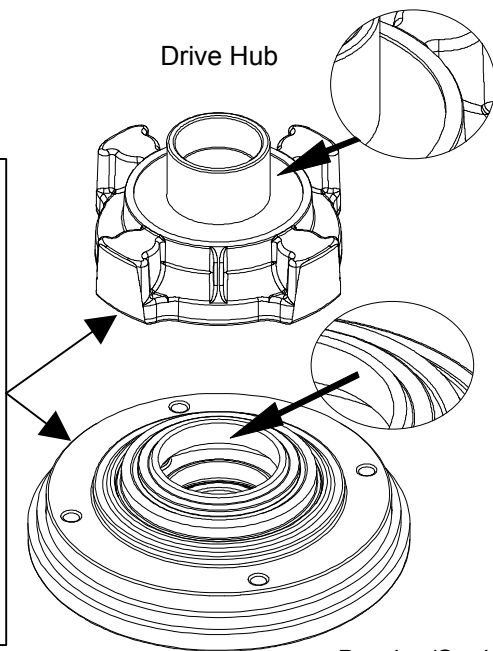

21001536 Trans

Drive Hub

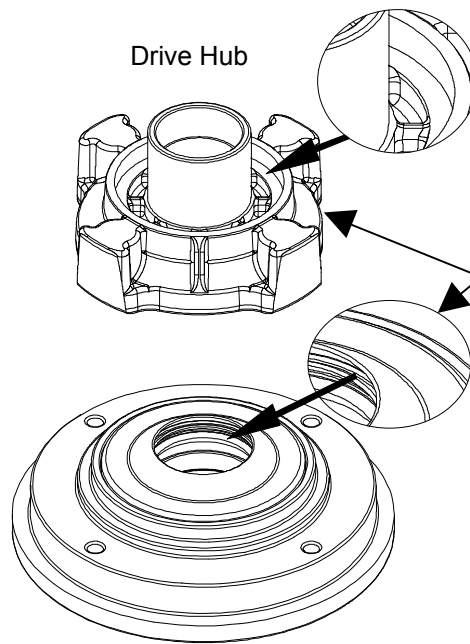

Triple Lip Tub Seal Assembly used with the 21001867 Hi-Torque Transmission Assembly.

NOTE: Sealing surface are on the O.D. of the aluminum spinner hub with no seal in the hub cavity.

21001867 Trans

The 21001868 Seal and Bearing kit must **only** be used with the High Torque Dual Drive service transmission. This seal kit will also be included in the 21001867 transmission assembly to insure proper assembly of parts. The clutch torque of the transmission is higher to compensate for increased drag on the Triple Lip Seal. With this series change it is important the correct seal kit is used on the proper transmission. This new seal and drive hub **must not** be used on older transmissions and the old seal and drive hub must not be used with a high torque transmission. A sticker is provided in the seal kit to be applied to the Outer Tub of the washer to indicate the washer was updated with a high torque dual drive transmission and new lip seal.









Instruction Sheet

12001995

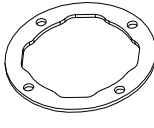
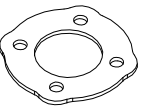
Description: Herrin/Atlantis Platform Triple Lip Seal and Bearing Kit

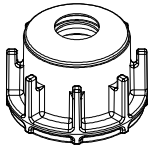
Repair Part Number: 21001868

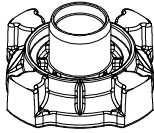
Kit includes:

 <p>Tub to Housing Seal</p>	 <p>Bearing, Seal and Housing</p>	 <p>Tub to Housing Gasket</p>	 <p>Basket to Hub Gasket</p>	 <p>Screw (Qty 4)</p>  <p>Screw (Qty 3)</p>	 <p>Seal Nut</p>	 <p>IMPORTANT THIS WASHER HAS BEEN UPDATED WITH A HIGH TORQUE TRANSMISSION AND REQUIRES SEAL KIT. IF REPAIR HUB AND SEAL KIT IS NEEDED, ORDER 21001868</p> <p>Sticker</p>	 <p>Spin Hub</p>	 <p>12001995 Instruction Sheet</p>
--	--	--	---	---	--	--	---	---



WARNING

To avoid risk of electrical shock, personal injury or death; disconnect electrical power before servicing.

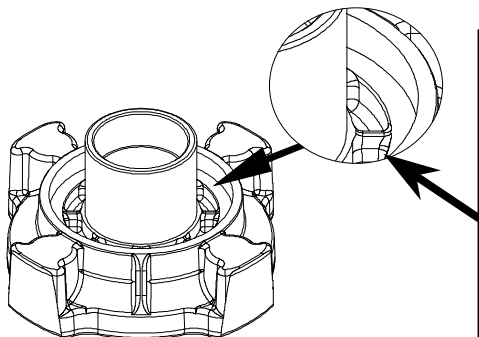

Triple Lip Tub Seal Assembly used with the 21001867 Hi-Torque Transmission Assembly.

NOTE: Sealing surface are on the O.D. of the aluminum spinner hub with no seal in the hub cavity.

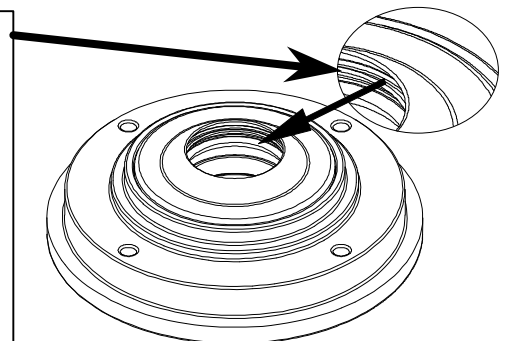

NOTE: The 21001868 Triple Lip Seal and Bearing kit must **only** be used with the High Torque Dual Drive service transmission. The 21001867 High Torque transmission will also include a Triple Lip Seal and Bearing for proper matching of parts. The High Torque transmission will have An "HT" next to the date code for field identification purposes. Do not use 21001868 Seal kit on older transmissions not designed to operate at higher torque levels. Always refer to Parts Pro or Microfiche for proper parts ordering. The 21001868 Triple Lip Seal kit will include a sticker to be placed on the Outer Tub of the washer to identify the washer has been modified with a High Torque Transmission and Triple Lip Seal kit.

TOOLS:

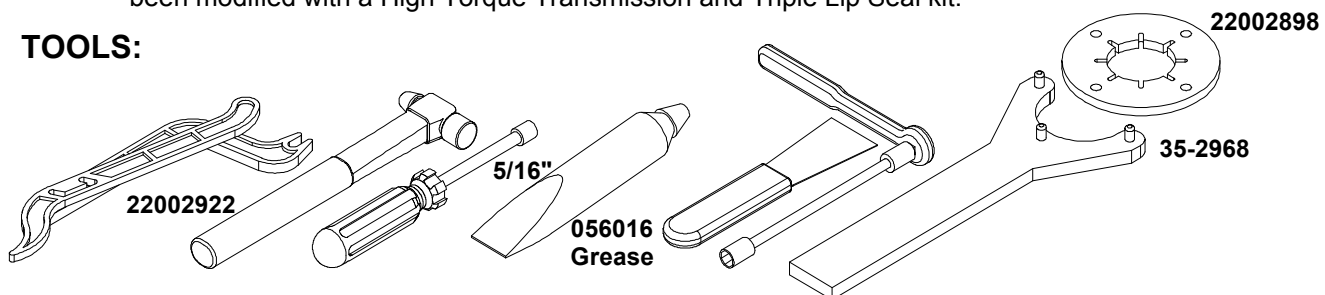

Procedure:

1. Disconnect the unit from the power source.
2. Lift Washer Top by inserting a plastic putty knife between Front Panel and Top Cover. Release Spring Clip from both sides of Washer Top. Support lid with free hand and rotate top till it comes to rest on hinge stop.
3. Remove Fabric Softener Dispenser by lifting straight up from Agitator.

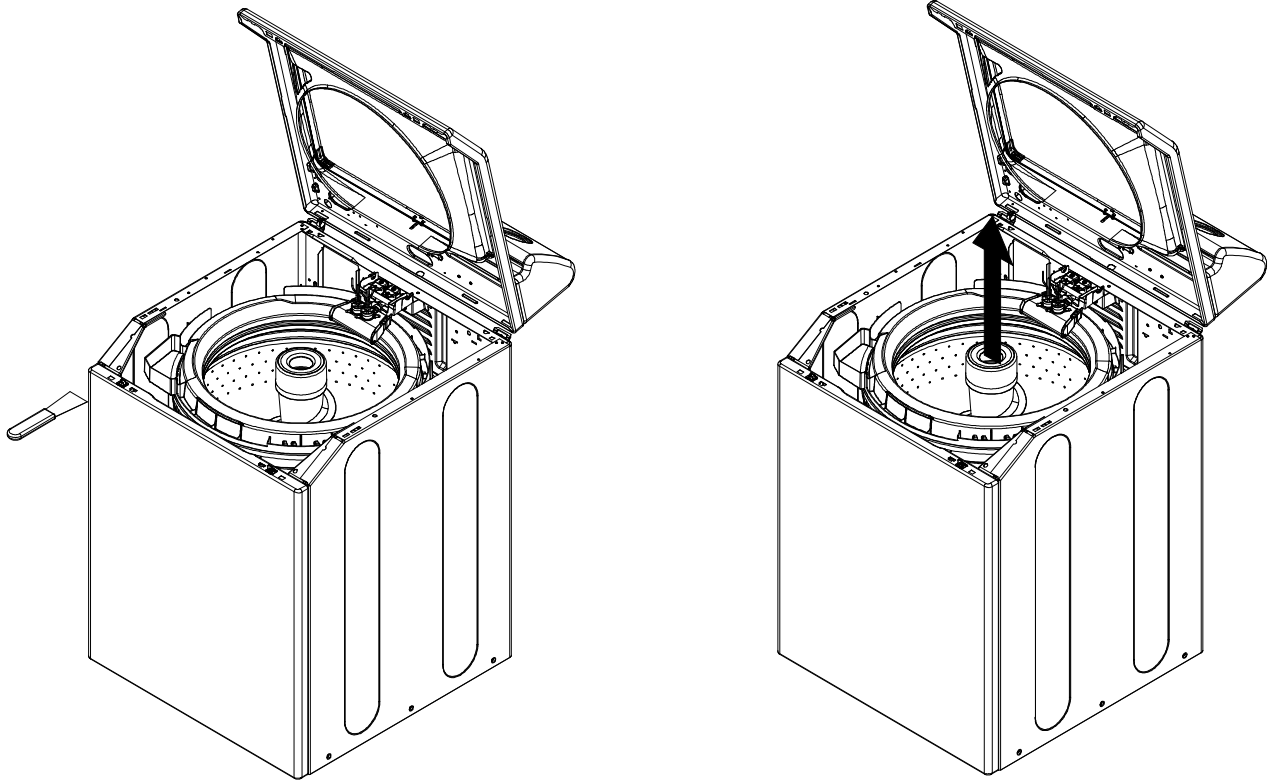

4. Remove Agitator by loosening bolt threaded into Transmission Output Shaft, located inside agitator opening.
5. Use Spanner Wrench (35-2968) and Seal Tool (22002898) to remove Seal Nut.

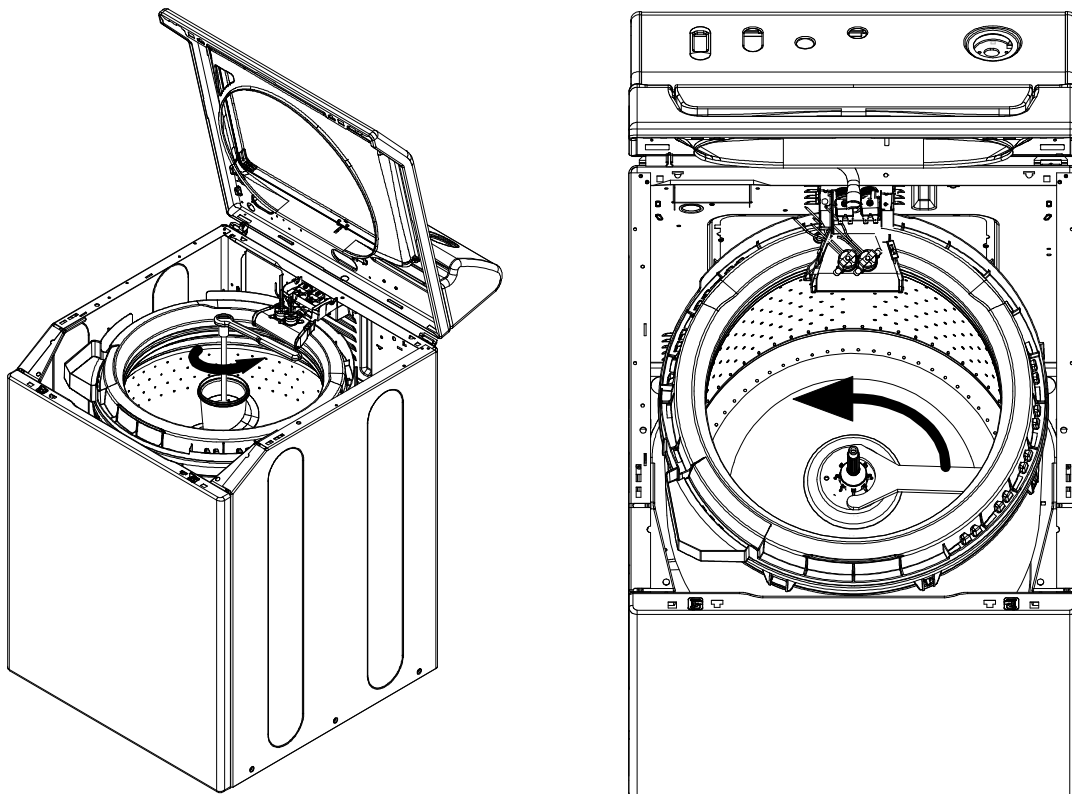

6. Remove Outer Tub Cover by pushing down on cover and unsnapping tabs. It may be necessary to remove Water Inlet Flume from back panel.

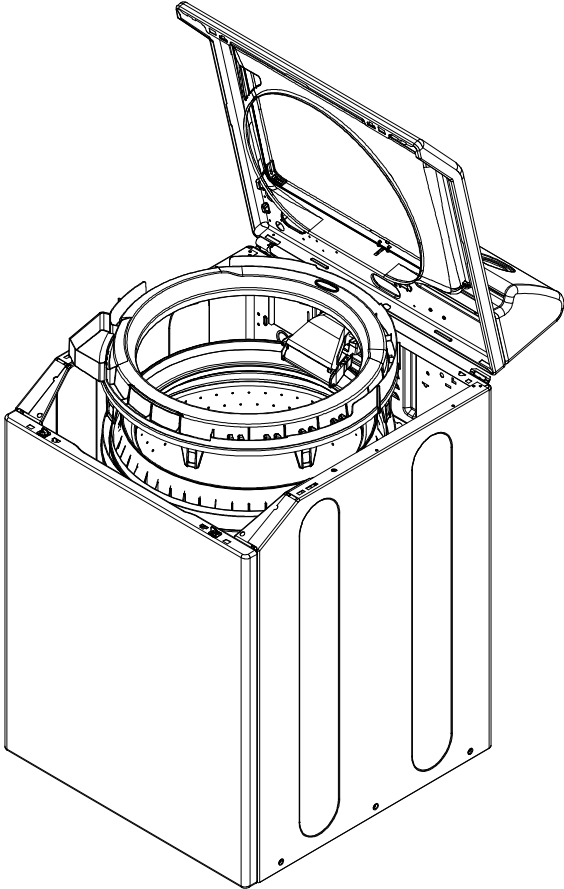

7. Remove Inner Tub Bolts and Inner Tub.

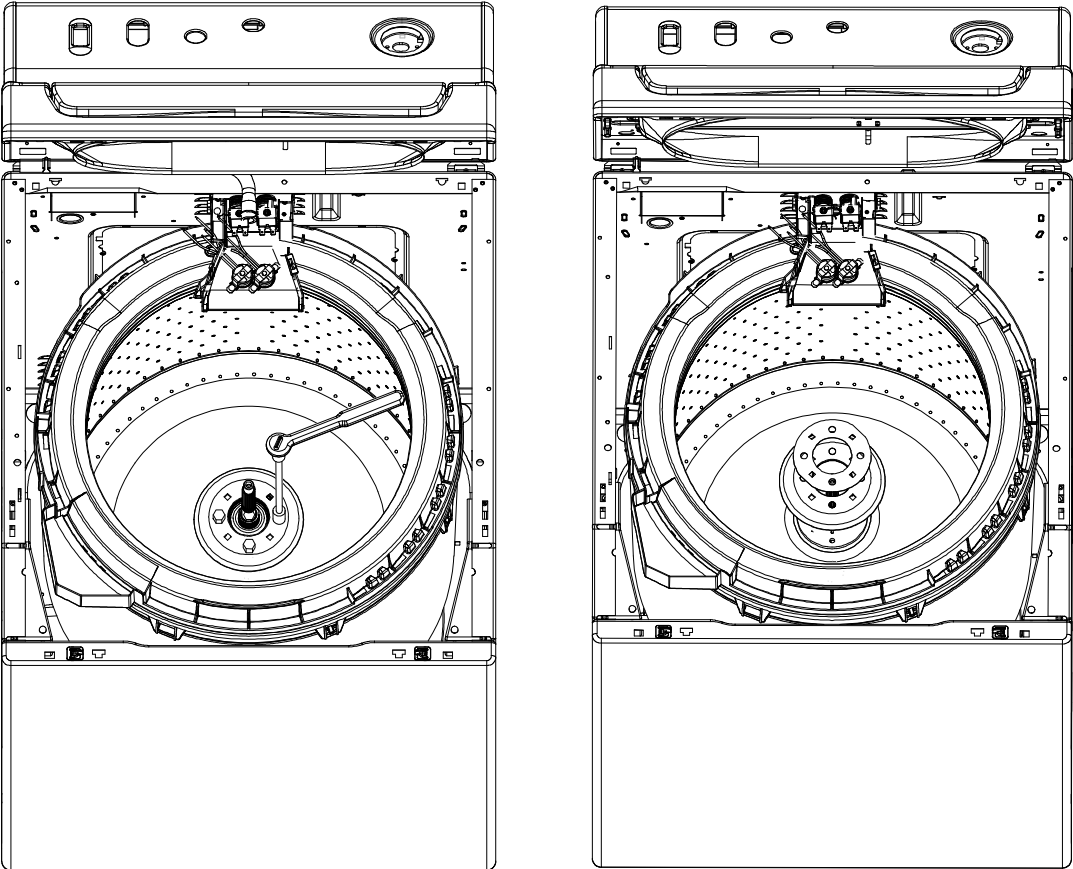

8. Remove Wash Tub Hub with Spanner Wrench (35-2968). Turn spanner counterclockwise to remove Hub.
9. Remove Front Panel.

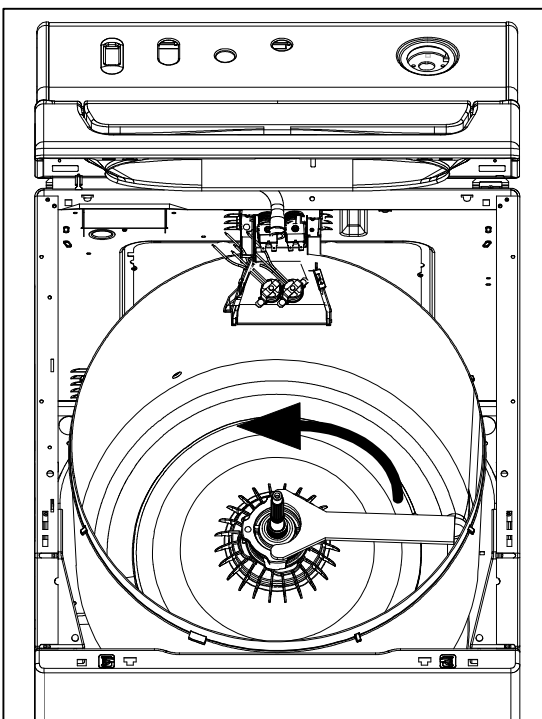

10. Remove Tub Springs with Spring Removal Tool (22002922).
11. Slide Drain Hose Clamp down and remove hose from washtub. Remove Pressure Hose from fitting on Outer Tub.
12. If this washer is being modified with a “High Torque Transmission” and “Triple Lip Seal”, place sticker in location shown. Only use this sticker if washer is being modified with a “High Torque” transmission and “Triple Lip Seal”.

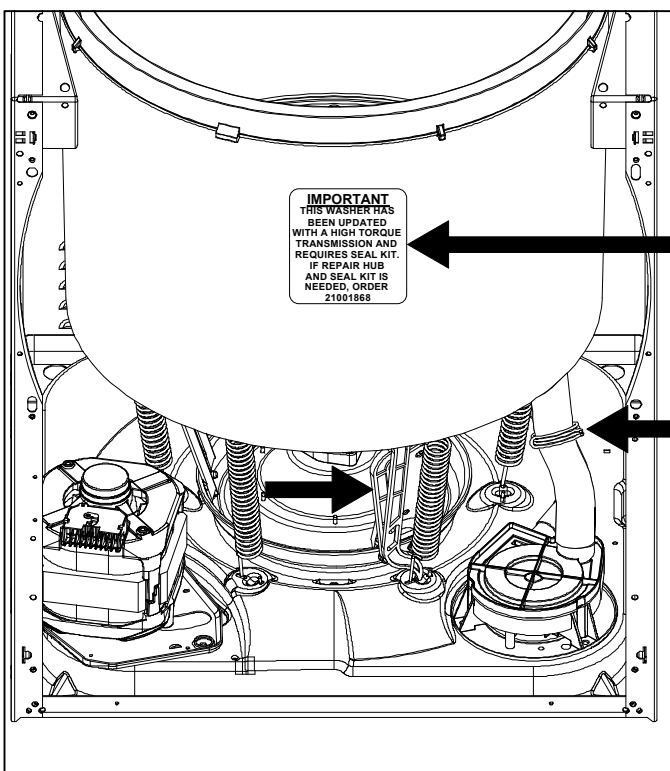

Note: Sticker indicating this machine has been modified with a “High Torque” service transmission and Seal kit 2101868. Placement of sticker is necessary when converting from the old transmission to the new “High Torque” transmission.

13. Remove 6 Outer Tub to Tub Support Housing screws. Spin assembly to access each screw. **NOTE:** Mark position of Outer Tub relative to the Tub Support Cover. Remove 4 screws inside Outer Tub. Remove Outer Tub.

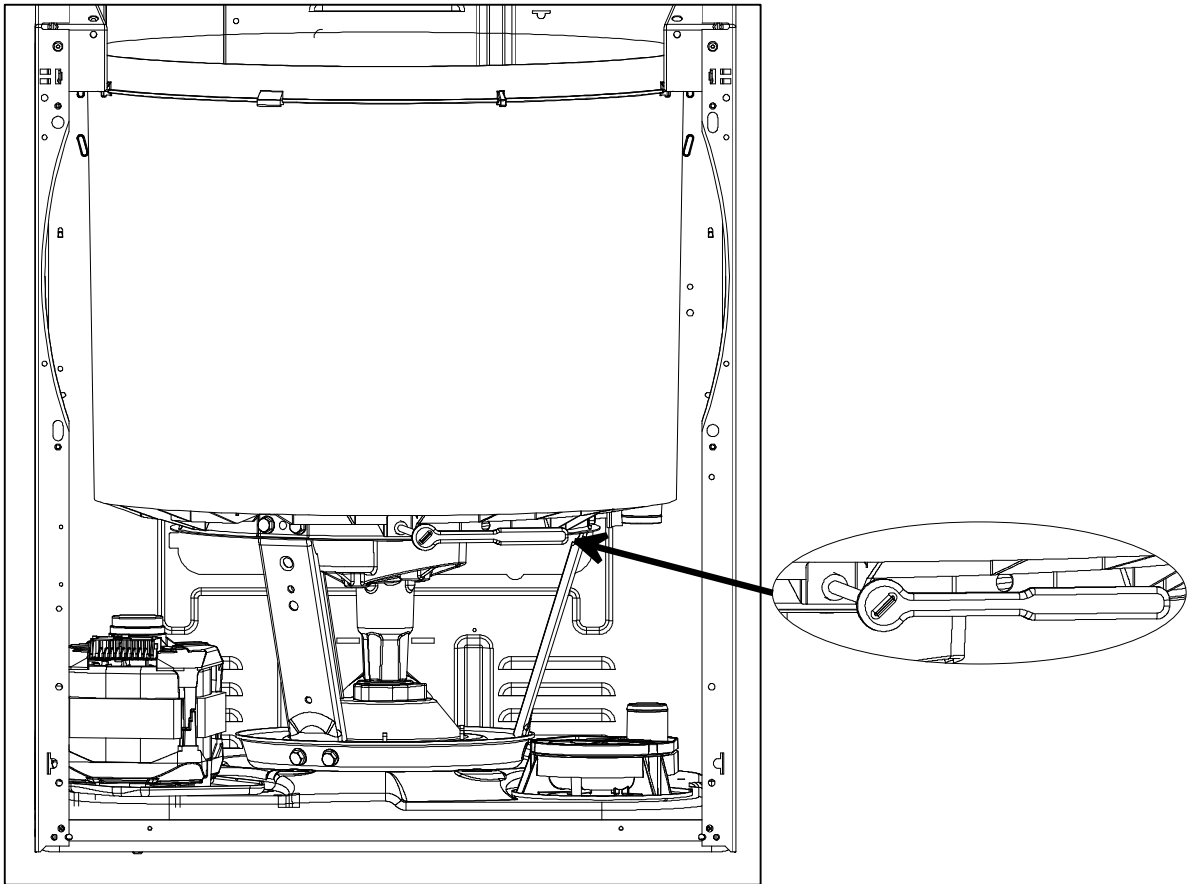

14. Remove 6 screws from Tub Supports to Tub Support Cover.

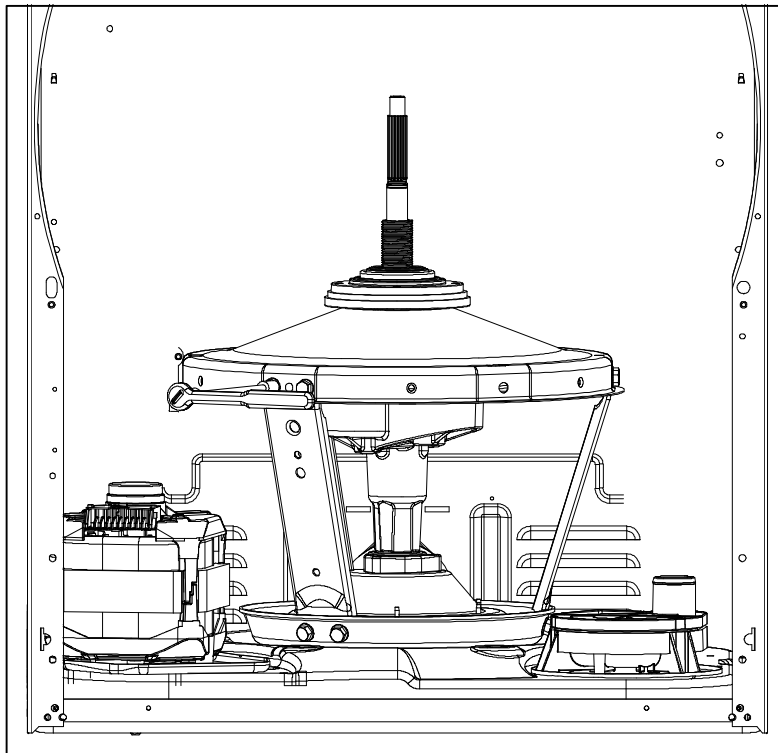

15. Remove 3 screws from Tub Support Cover, bearing and seal.

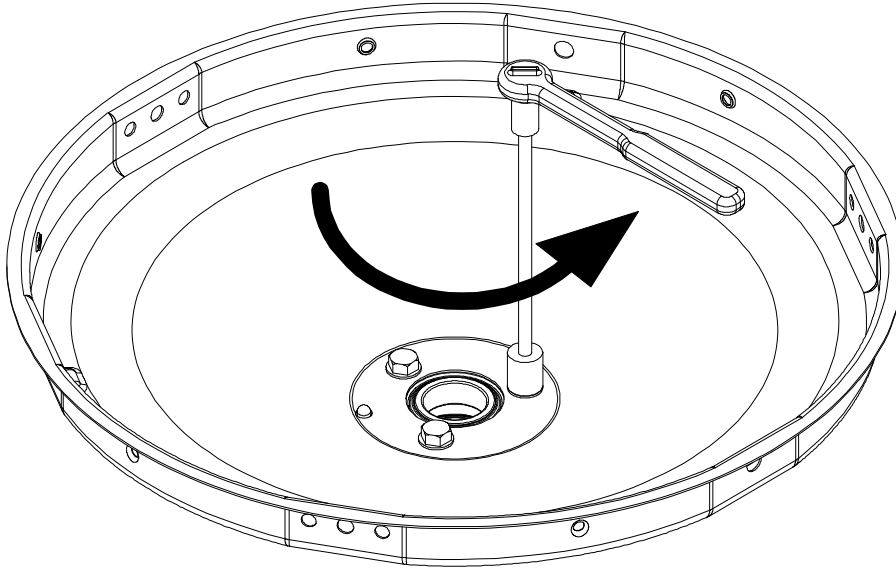

16. Apply center seal grease (056016) to Seal Nut and Triple Lip Seal before installing.

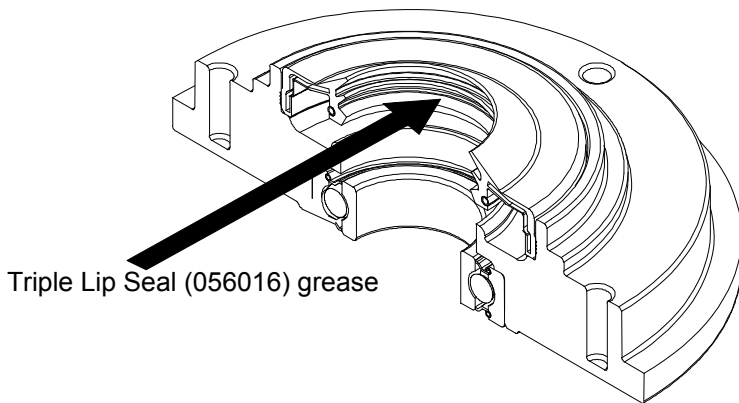

Triple Lip Seal (056016) grease

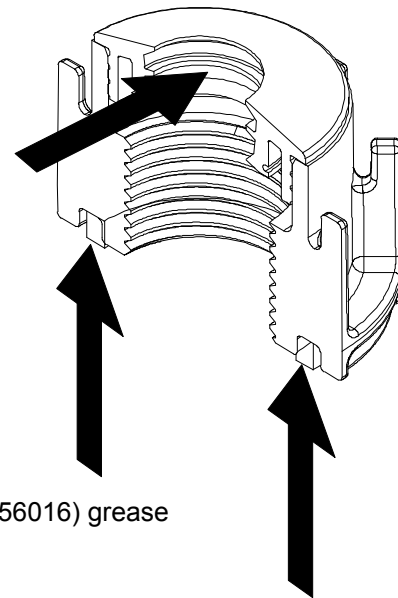

Seal Nut (056016) grease

17. Reassemble washer.

18. Check all hose connections and test unit for proper operation.