

Technical Bulletin

MAYTAG®

Type Policy Letter
√ Service Information

Date: October 2005

No: TDL-0086-B
Page 1 of 8

Attention Service Managers
√ Service and Parts Managers

Models **Current Production:** NAV2335AWW, PAVT910AWW, CW5500W, CAV2005AWW, AAV7000AWW, NAV3335AWW, CW6500W, CAV4004AWW, PAVT920AWW, AAV8005EWW, NAV5805AWW, CW9505W, NAV8805EWW, MAV1655AWW, MAV1755AWW, PAV2755AAW, MAV2755AJW, MAV2755SAWW, PAV3855AAW, MAV3855AGW, MAV3855AKW, MAV3855SAWW, MAV5920AGW, AAV4000AWW, CAV1004AWW, HAV1200ARW, HAV1200AWW, PAVT915AWW, AAV7000AGW, AAV7000AJW, AAV7000AKW, CAV2004AJW, CAV2004AKW, NAV2335AJW, AAV8000AGW, AAV8000AJW, CAV4004AGW, AAV9000AGW, HAV4200AKW, HAV4200ATW, HAV4200AWW, MAV208DAWW, MAV2755AWW, MAV2757AWW, MAV308DAWW, MAV3757AWW, MAV3758AWW, MAV3855AWW, MAV3905AWW, MAV3955EWW, MAV408DAWW, MAV4755AWW, MAV4757AWW, MAV4758AWW, MAV551EEWW, MAV5758EWW, MAV5920EWW, MAVT236AWW, MAVT346AWW, MAVT446AWW, MAVT546EWW

Brand
Admiral
Amana
Crosley
Magic Chef

Product
Laundry

Previous Production: MAV5960AW*, MAV6200AW*, MAV7200AW*, MAV7600AW*, MAV7700AW*, MAV7650AW*, MAV9600EW*, MAV7600AG*, MAV7600BG*, MAV6300AG*, MAV6300BG*, MAV7750AG*, MAV7750BG*, MAV7450AW*, MAV7580EW*, MAV7357AW*, MAV6357AW*, MAV7358AW*, MAV7757AW*, MAV8757AW*, MAV6650AW*, MAV9750AW*, MAV8551AW*, MAV7551AW*, MAV6451AW*, MAV6358AW*, MAVT634AW*, MAVT834AW*, MAV6260AW*, MAV6548AW*, MAV6601AW*, MAV7260AW*, MAV8260AW*, MAV8601AW*, MAV9501EW*, MAV7501EW*, MAV6300CG*, MAV7600CG*, MAV7750CG*, PAV2200AW*, PAV2300AW*, PAV5000AW*, CAV2000AG*, CAV2000AJ*, CAV2000AK*, CAV2000AW*, CAV4000AW*, CAV4050AW*, MAV2200AJ*, PAV2200AA*, PAV2200AK*, PAV2360AW*, PAV3200AA*, PAV3240AW*, PAV3200AW*, PAV3300AW*, PAV3360AW*, PAV4960AW*, PAV5157AW*, PAV5158AW*, AAV1200AG*, AAV1200AJ*, AAV1200AK*, AAV1200AR*, AAV2200AG*, AAV2200AJ*, AAV4200AG*, CW5000*, CW6000*, CW7500*, HAV1200AR*, HAV1200AW*, HAV4200AK*, HAV4200AT*, HAV4200AW*, DLW231RAW, LNC6766A*, LNC6764A*, LNC6762B01, LNC6762B71, PAV2200AG*, PAV2200AR*, LNC6760B71, MAV7260BW*, MAVT734EW*, LNC6766B71, PAV3300AG*, PAV3300AK*, PAV2300AG*, MAV6457AW*, MAV7557EW*, MAV8557AW*, MAV6458AW*, MAV9557EW*, ALW221RJW, PAV1200AW*, PAVT234AW*, PAVT244AW*, PAVT344AW*, PAVT444AW*, HAV2557AW*, HAV2558AW*, HAV4657AW*, HAV2360AW*, HAV2460AW*, HAV3460AW*, AAV1100AW*, PAV1100AW*, PAVT144AW*, MAV6451AG*, MAV9750AG*, CW5500*, CW6500*, CW8500*, CAV2004AW*, CAV2004AJ*, CAV2004AK*, CAV4004AW*, CAV4004AG*, CAV1000AW*, MAV9504EW*, MAV7657EW*, MAV9657EW*, MAVT754EW*, PAVT454EW*, HAV4657EW*, MAV7504EW*, AAV9000AW*, AAV7000AW*, AAV8000AW*, PAVT234AW*, PAVT244AW*, PAVT344AW*, PAVT444AW*, LNC6762B01, LNC6762B71, LNC6764A*, LNC6766B71, LNC6760B71, CAV2004AJ*, CAV2004AK*, AAV1200AG*, AAV1200AJ*, AAV1200AK*, AAV1200AR*, AAV2200AJ*, AAV2200AG*, AAV4200AG*, ALW221RJW, CAV1000AW*, AAV1100AW*, CAV4004AG*, CW5500*, CW6500*, CW8500*, CAV2004AW*, CAV4004AW*, PAVT454EW*, PAV1100AW*, PAVT144AW*, HAV2360AW*, HAV2460AW*, HAV3460AW*, HAV2557AW*, HAV2558AW*, HAV4657AW*, HAV4657EW*, HAV1200AR*, HAV1200AW*, HAV4200AK*, HAV4200AT*, HAV4200AW*, MAV2200AJ*, PAV2300AG*, PAV3300AG*, PAV3300AK*, MAV3350AG*, PAVT134AW*, PAVS244AW*, PAVS234AW*, AAV4000AW*, CAV1004AW*, HAV2357AW*, MAV3855AW*

Issue New Hub and Seal.

Warranty Standard product manufacturing warranty applies.

Action

Sept 2005 production introduced a one piece integral hub/with seal assembly. The 21001868 seal kit that was used on prior models has also been modified with the new hub.

The new Integral Hub with Seal will update washer to current production parts.

Refer to the parts catalog for ordering the correct replacement parts.

New

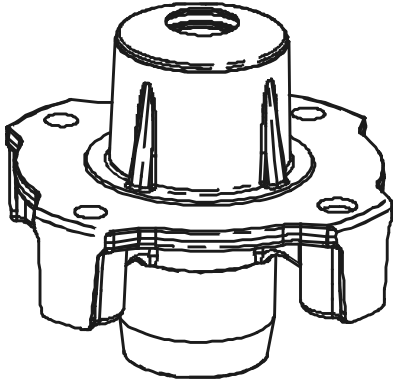

Old

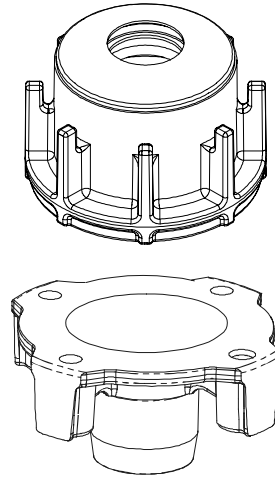

Instruction Sheet





16026441

2205892

Description: Herrin/Atlantis Platform Triple Lip Seal and Bearing Kit

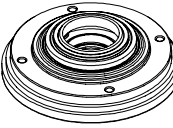
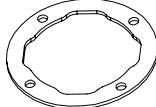
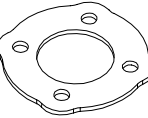
Repair Part Number: 21001868

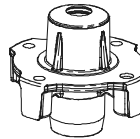
Kit includes: 2205891

| | | | | | | | |
|--|--|--|---|---|---|---|---|
|  <p>Tub to Housing Seal</p> |  <p>Bearing, Seal and Housing</p> |  <p>Tub to Housing Gasket</p> |  <p>Basket to Hub Gasket</p> |  <p>Screw (Qty 4)</p>  <p>Screw (Qty 3)</p> | <p>IMPORTANT THIS WASHER HAS BEEN UPDATED WITH A HIGH TORQUE TRANSMISSION AND REQUIRES SEAL KIT. IF REPAIR HUB AND SEAL KIT IS NEEDED, ORDER 21001868</p> <p>Sticker</p> |  <p>Spin Hub</p> |  <p>16026441 Instruction Sheet</p> |
|--|--|--|---|---|---|---|---|



WARNING

To avoid risk of electrical shock, personal injury or death; disconnect electrical power before servicing.

Tools:

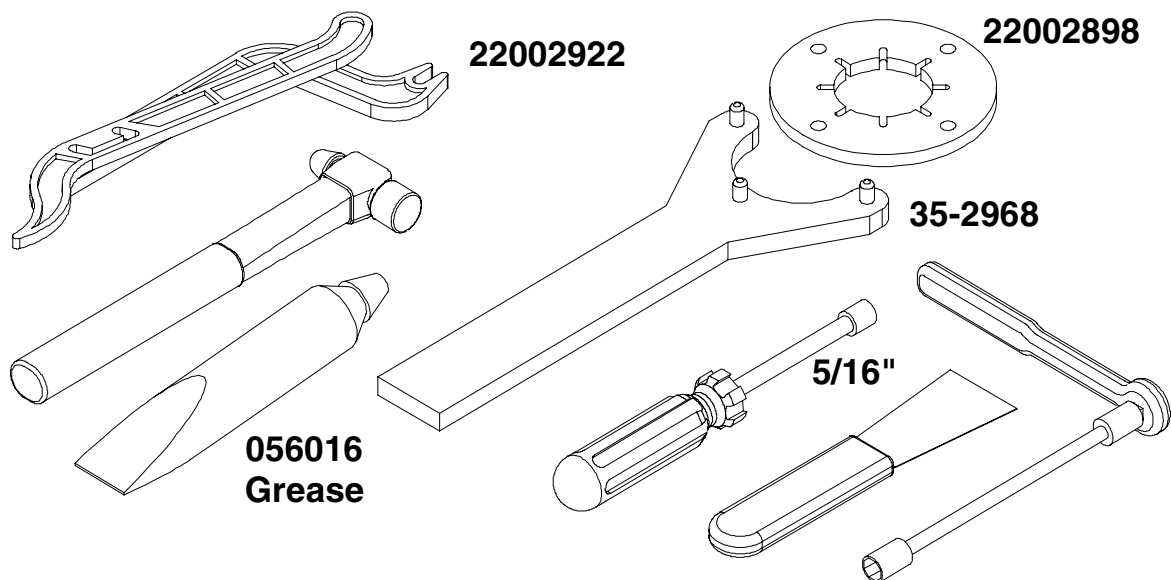

Note: The 21001868 Triple Lip Seal and Bearing kit must **only** be used with the High Torque Dual Drive service transmission. The 21001867 High Torque transmission will also include a Triple Lip Seal and Bearing for proper matching of parts. The High Torque transmission will have An "HT" next to the date code for field identification purposes. Do not use 21001868 Seal kit on older transmissions not designed to operate at higher torque levels. Always refer to Parts Pro or Microfiche for proper parts ordering. The 21001868 Triple Lip Seal kit will include a sticker to be placed on the Outer Tub of the washer to identify the washer has been modified with a High Torque Transmission and Triple Lip Seal kit.

Procedure:

1. Disconnect the unit from the power source.
2. Lift Washer Top by inserting a plastic putty knife between Front Panel and Top Cover. Release Spring Clip from both sides of Washer Top. Support lid with free hand and rotate top till it comes to rest on hinge stop.
3. Remove Fabric Softener Dispenser by lifting straight up from Agitator.

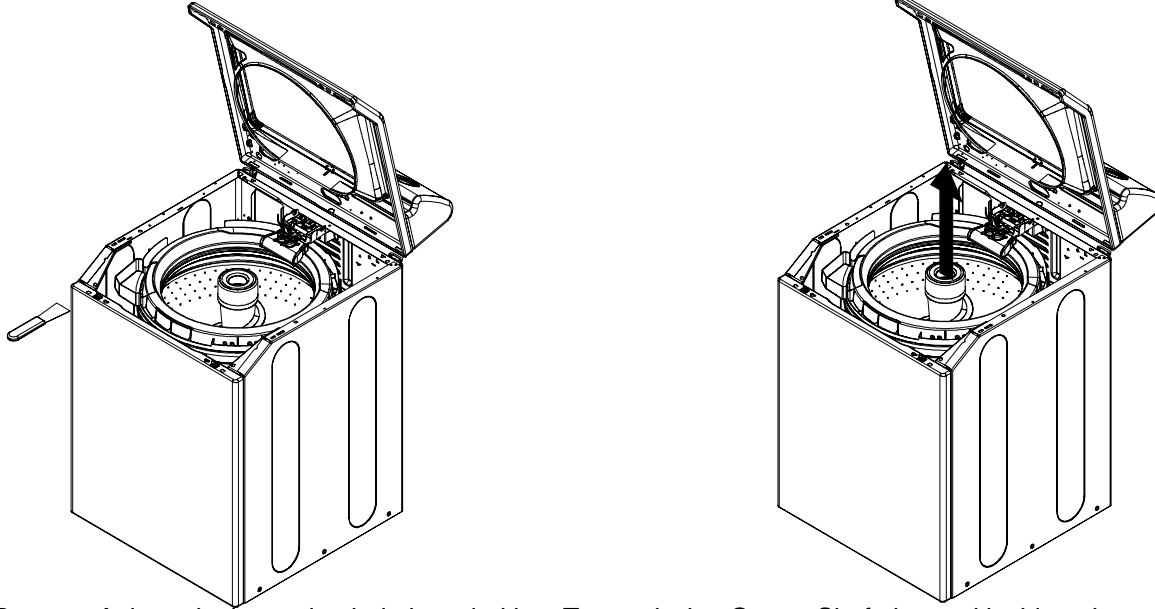

4. Remove Agitator by loosening bolt threaded into Transmission Output Shaft, located inside agitator opening.
5. Use Spanner Wrench (35-2968) and Seal Tool (22002898) to remove Seal Nut if present.

NOTE: September 2005 production, introduced a one piece integral hub/ with seal. Units built prior had a separate hub and seal nut.

Please refer to attached TSB TDL-0086-B on last page of instruction sheet.

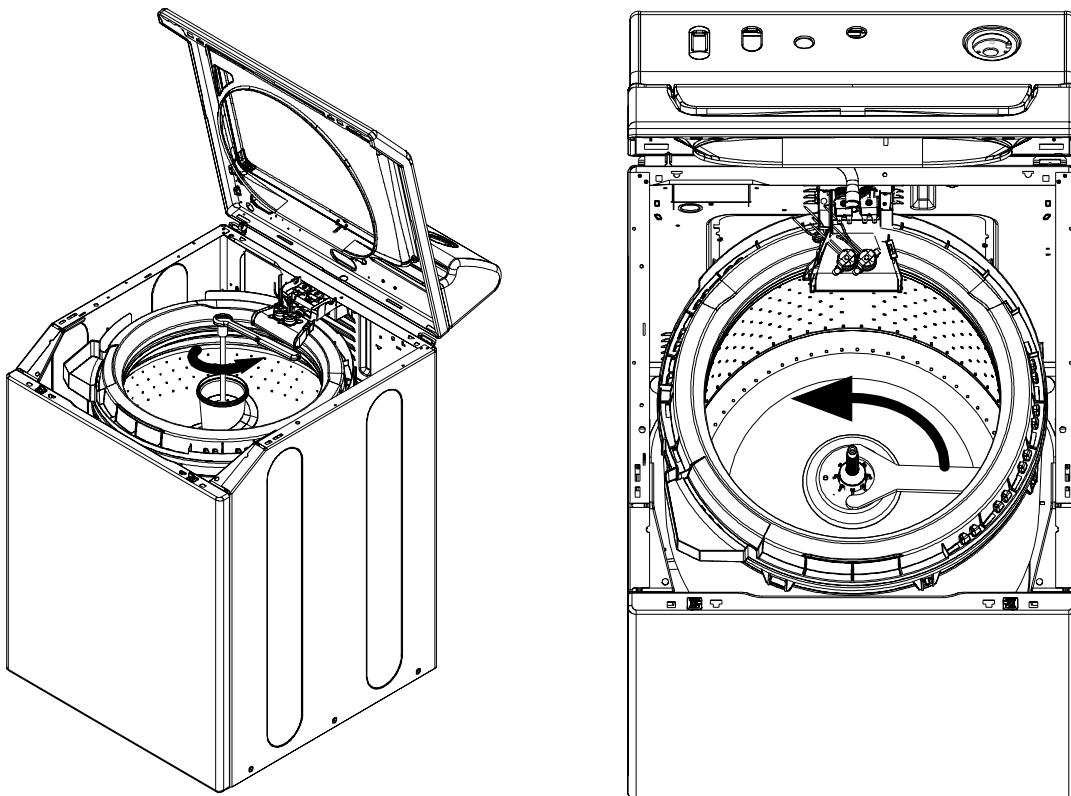

6. Remove Outer Tub Cover by pushing down on cover and unsnapping tabs. It may be necessary to remove Water Inlet Flume from back panel.

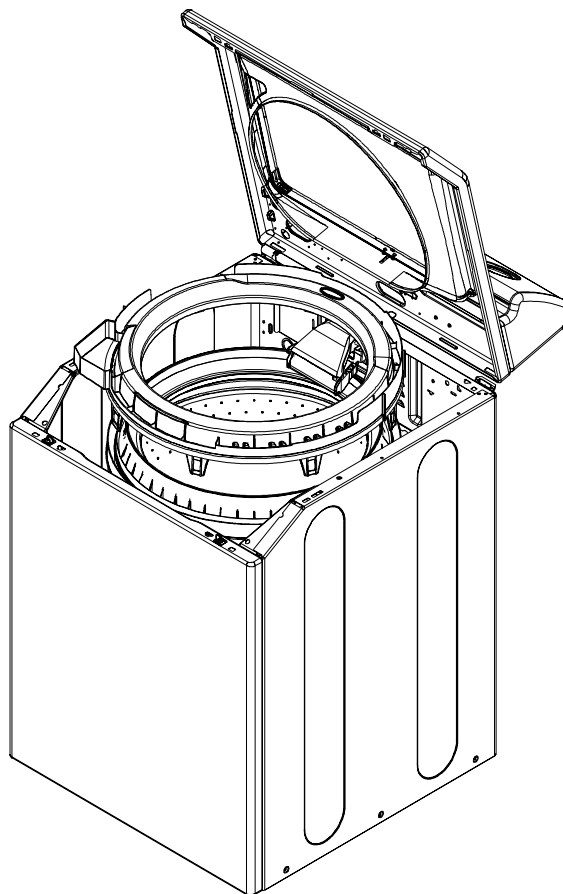

7. Remove Inner Tub Bolts and Inner Tub.

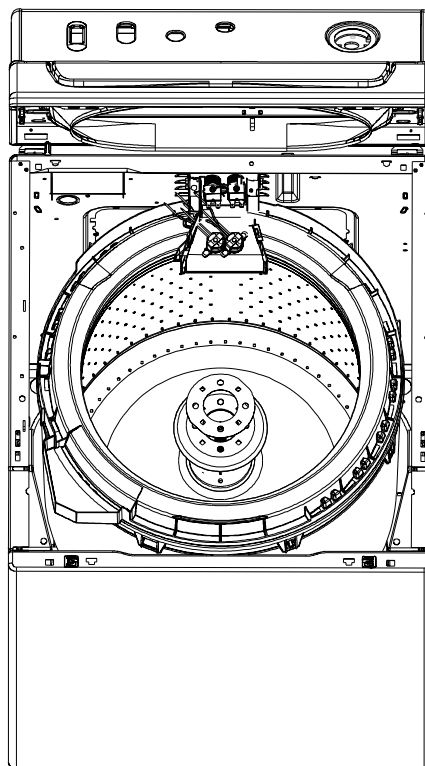
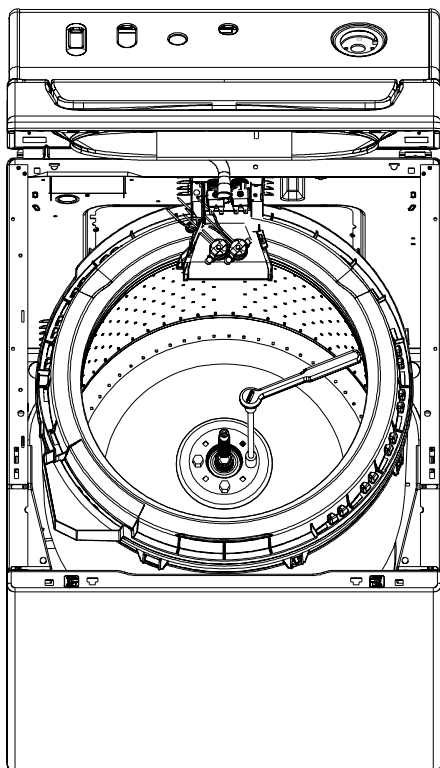

8. Remove Wash Tub Hub with Spanner Wrench (35-2968). Turn spanner counterclockwise to remove Hub.
9. Remove Front Panel.

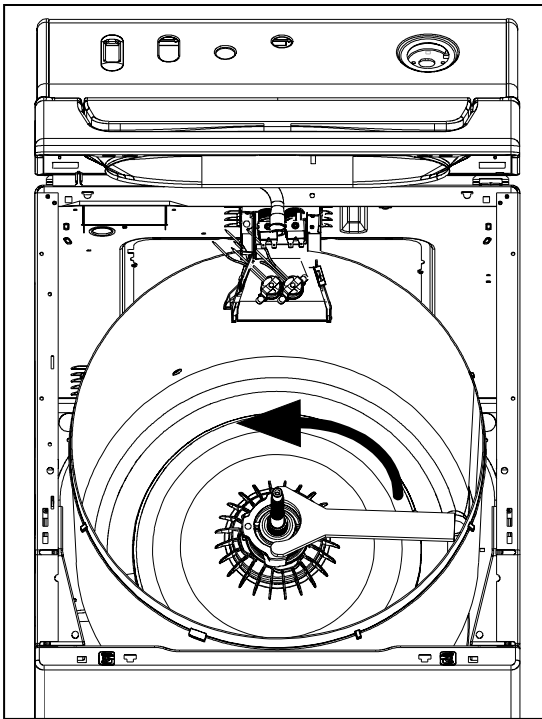

10. Remove Tub Springs with Spring Removal Tool (22002922).
11. Slide Drain Hose Clamp down and remove hose from washtub. Remove Pressure Hose from fitting on Outer Tub.
12. If this washer is being modified with a “High Torque Transmission” and “Triple Lip Seal”, place sticker in location shown. Only use this sticker if washer is being modified with a “High Torque” transmission and “Triple Lip Seal”.

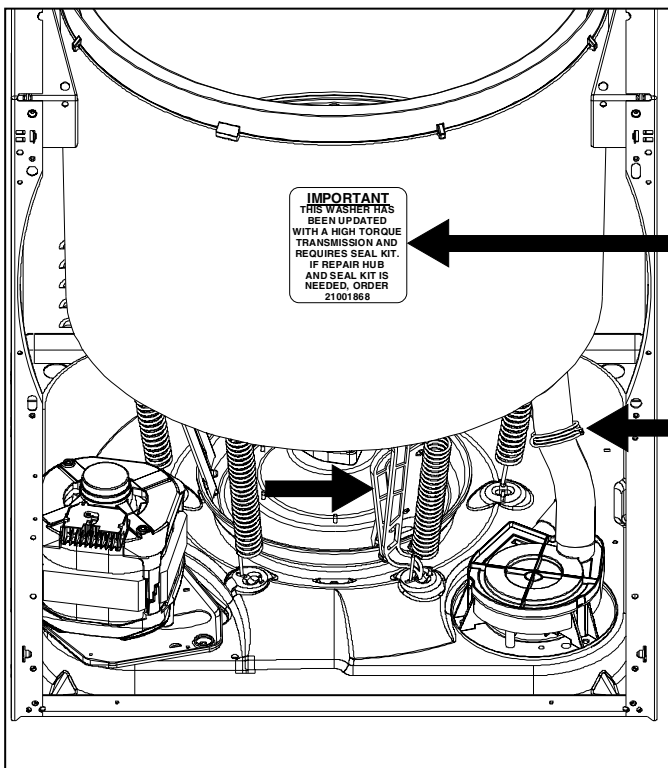

Note: Sticker indicating this machine has been modified with a “High Torque” service transmission and Seal kit 2101868. Placement of sticker is necessary when converting from the old transmission to the new “High Torque” transmission.

13. Remove 6 Outer Tub to Tub Support Housing screws. Spin assembly to access each screw. **NOTE:** Mark position of Outer Tub relative to the Tub Support Cover. Remove 4 screws inside Outer Tub. Remove Outer Tub.

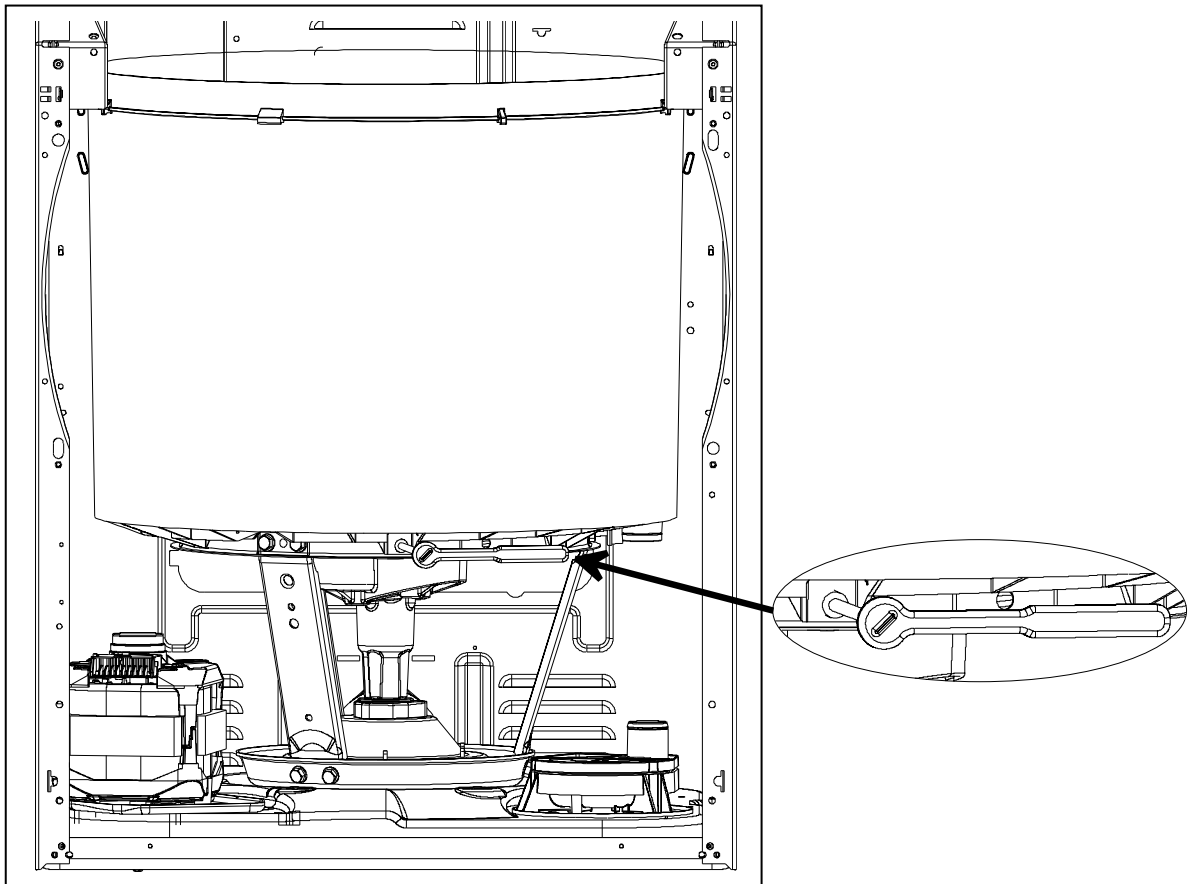

14. Remove 6 screws from Tub Supports to Tub Support Cover.

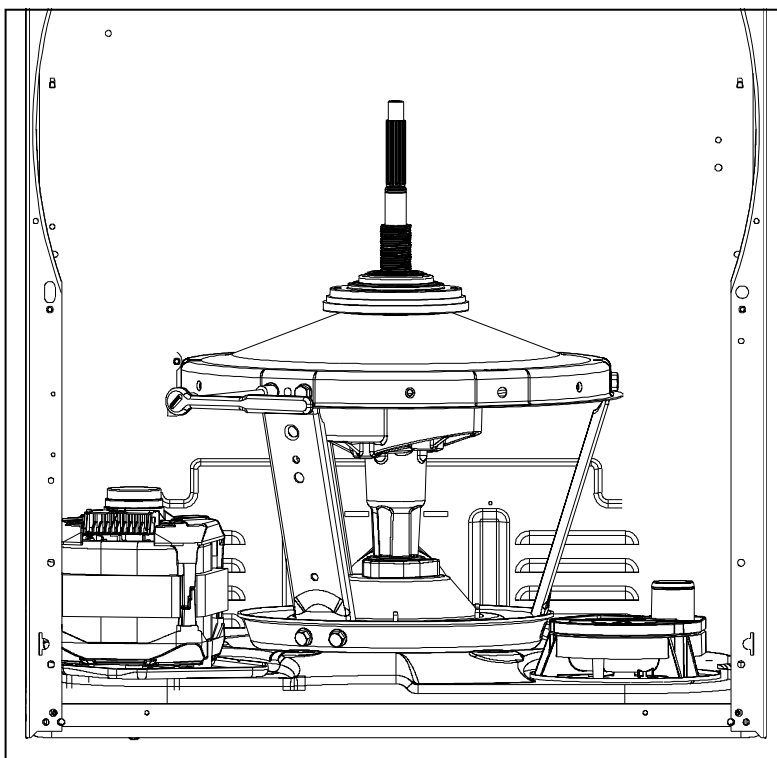

15. Remove 3 screws from Tub Support Cover, bearing and seal.

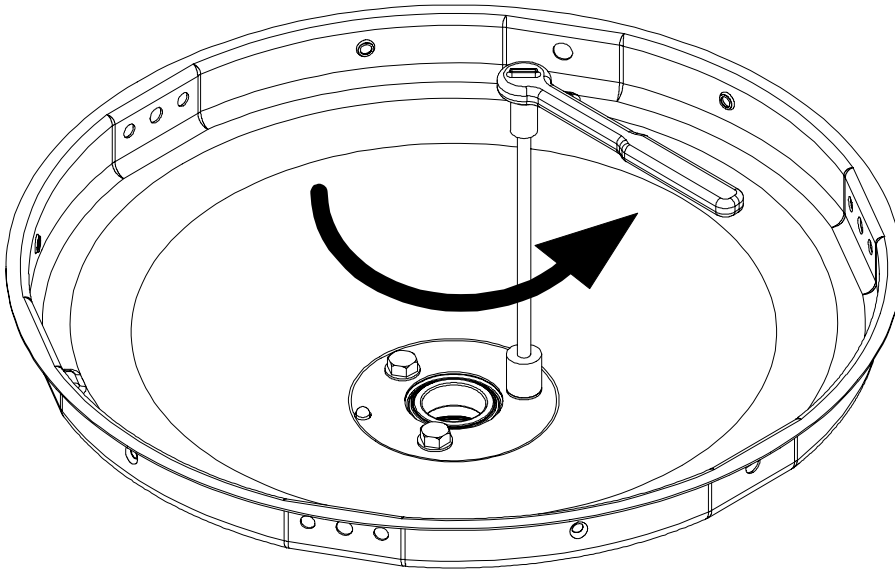

16. Apply center seal grease (056016) to the Triple Lip Seal and Agitator Shaft Seal before installing.

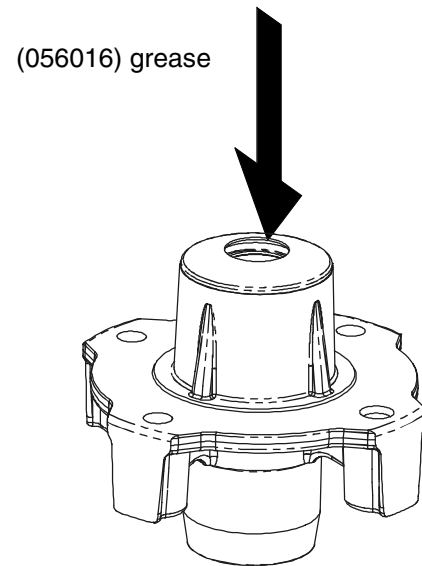
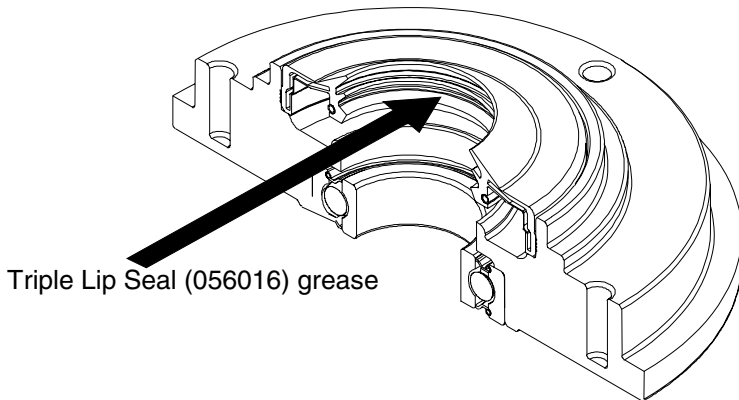

17. Reassemble washer.

NOTE: New integral hub with seal will update washer to current production parts.

18. Check all hose connections and test unit for proper operation.