

# **Descriptive Technical Documentation**

**- Model-dependent -**

## **DTD no. 11-4800**

**Model(s): W 4840, W 4800**



# Contents

## General Information

- A**      **Warning and Safety Instructions**
- B**      **Modification History**
- C**      **Technical Data**
- D**      **Layout of Electrical Components**

## Function Groups

### 010      **Housing, Lid, Secure Transport**

<b>1</b>	<b>Technical Data</b> .....	<b>010-2</b>
<b>3</b>	<b>Fault Repair</b> .....	<b>010-3</b>
3.1	Vibrations during spin cycle .....	010-3
<b>4</b>	<b>Service</b> .....	<b>010-4</b>
4.1	Lid – Remove .....	010-4
4.2	Front panel – Remove .....	010-5
4.3	Float switch (B8) .....	010-6

### 020      **Door, Magnet, Lock**

<b>1</b>	<b>Technical Data</b> .....	<b>020-2</b>
<b>2</b>	<b>Function</b> .....	<b>020-3</b>
2.1	Pull door lock (A2) .....	020-3
2.1.1	Electromagnetic door lock .....	020-3
2.1.2	Safety requirements .....	020-3
<b>3</b>	<b>Fault Repair</b> .....	<b>020-4</b>
3.1	Door lock (A2) does not lock .....	020-4
<b>4</b>	<b>Service</b> .....	<b>020-5</b>
4.1	Door lock (A2) – Open manually .....	020-5
4.2	Door lock (A2) – Remove .....	020-6
4.3	Door porthole, door latch and hinge – Remove .....	020-7

### 030      **Suds container, Drum, Bearing, Heater element**

<b>1</b>	<b>Technical Data</b> .....	<b>030-2</b>
<b>2</b>	<b>Function</b> .....	<b>030-3</b>
2.1	Foam sensing .....	030-3
2.1.1	Foam when heating during the main wash cycle .....	030-3
2.1.2	Foam at rinse cycle water intake (in the drum vent or in the siphon) .....	030-3

2.1.3	Foam during spin cycle (water sheet) . . . . .	030-3
2.2	Light in the door concertina seal . . . . .	030-4
2.3	Heater . . . . .	030-4
<b>4</b>	<b>Service</b> . . . . .	<b>030-5</b>
4.1	Temperature sensor (NTC resistor, R30) . . . . .	030-5
4.2	Air trap – Clean. . . . .	030-5
4.3	Door sealing ring – Replace . . . . .	030-5
<b>040</b>	<b>Water intake</b>	
<b>1</b>	<b>Technical Data</b> . . . . .	<b>040-2</b>
<b>2</b>	<b>Function</b> . . . . .	<b>040-3</b>
2.1	Float switch (B8). . . . .	040-3
2.2	Hot water intake control . . . . .	040-3
2.3	Automatic load control / Intelligent water intake (IWE) . . . . .	040-3
2.4	Water intake monitoring – water control system (WCS) . . . . .	040-4
2.5	Water overflow monitoring . . . . .	040-4
2.6	Flow meter (B3/4). . . . .	040-4
2.7	Water path control unit, motor water path control unit (M24). . . . .	040-5
<b>4</b>	<b>Service</b> . . . . .	<b>040-6</b>
4.1	Flow meter (B3/4). . . . .	040-6
<b>050</b>	<b>Water drain</b>	
<b>1</b>	<b>Technical Data</b> . . . . .	<b>050-2</b>
<b>2</b>	<b>Function</b> . . . . .	<b>050-3</b>
2.1	Water drain monitoring. . . . .	050-3
<b>060</b>	<b>Drive</b>	
<b>1</b>	<b>Technical Data</b> . . . . .	<b>060-2</b>
<b>2</b>	<b>Function</b> . . . . .	<b>060-3</b>
2.1	Spin lock . . . . .	060-3
2.2	Toothed V-belt . . . . .	060-3
2.3	Motor overheating protection. . . . .	060-3
2.4	Tachogenerator . . . . .	060-4
<b>3</b>	<b>Fault Repair</b> . . . . .	<b>060-5</b>
3.1	Drum drive defective . . . . .	060-5
<b>4</b>	<b>Service</b> . . . . .	<b>060-6</b>
4.1	Tachogenerator . . . . .	060-6
4.2	Toothed V-belt – Mount . . . . .	060-6
4.3	Drive MXT 40 . . . . .	060-7
<b>070</b>	<b>Fascia panel, Control electronic</b>	
<b>1</b>	<b>Technical Data</b> . . . . .	<b>070-2</b>
<b>2</b>	<b>Function</b> . . . . .	<b>070-3</b>
2.1	Child safety sensor. . . . .	070-3
2.2	Action after a power failure . . . . .	070-3
2.3	Programming function (HY IV E). . . . .	070-4
2.3.1	Water Plus . . . . .	070-4
2.3.2	Gentle cycle . . . . .	070-4

2.3.3	Suds cooling	070-4
2.3.4	Memory	070-4
2.3.5	Buzzer	070-4
2.3.6	Language	070-4
2.3.7	Contrast	070-4
2.3.8	Standby	070-4
2.3.9	Water intake	070-5
2.3.10	Max. water level	070-5
2.3.11	Country version	070-5
2.3.12	Max. spin speed	070-5
2.3.13	Load automatic	070-5
2.3.14	Imbalance values	070-5
2.3.15	Central unit	070-5
2.3.16	Heater output	070-5
2.3.17	Low water pressure	070-5
2.3.18	Allergy	070-6
2.3.19	Sensor controlled rinse cycle	070-6
2.3.20	Temperature	070-6
2.3.21	Current volume meter (VSZ)	070-6
2.3.22	Keypad tone	070-6
2.3.23	Reset	070-6
2.3.24	Imbalance sensor	070-7
2.3.25	Water valves	070-7
2.3.26	Display	070-7
2.3.27	Appliance	070-7
2.3.28	Load indication	070-7
2.3.29	Drum light	070-8
2.3.30	Brightness	070-8
2.3.31	Fascia panel type	070-8
2.3.32	Hygiene	070-8
2.3.33	Prewash at heavy soil	070-9
2.3.34	Chlorine / Bleach agent intake	070-9
2.4	Service function	070-9
2.4.1	Component test	070-9
2.4.2	Sensor test	070-9
2.4.3	Operating hours meter	070-9
2.4.4	Operating	070-9
2.5	Demo mode	070-10
2.5.1	Demo program mode	070-10
2.5.2	Demo program mode (program simulation)	070-10
2.6	Fault dialogue	070-10
<b>3</b>	<b>Fault Repair</b>	<b>070-11</b>
3.1	All LEDs flash	070-11
3.2	LED Start flashes rapidly	070-11
3.3	Sevensegment display: "--"	070-12
3.4	Display indicates: Program is locked	070-12
3.5	Display indicates: Appliance is locked	070-13
3.6	Display indicates: Locked, enter code	070-14
3.7	Display indicates: No start. Demo mode activated	070-14
3.8	Display indicates: Waterproof, shut off faucet	070-15
3.9	Display indicates: Water drain fault, check drain	070-15
3.10	Display indicates: Technical fault	070-16
3.11	F 0 No fault	070-16
3.12	F 1 NTC short circuit water / heater	070-17
3.13	F 2 NTC open circuit water / heater	070-17

3.14	F 10 Water intake fault cold water	070-18
3.15	F 11 Water drain	070-20
3.16	F 15 Water intake fault hot water	070-20
3.17	F 16 Oversudsing	070-21
3.18	F 19 Flow meter is sluggish (flow meter (B3/4) / current volume meter)	070-22
3.19	F 20 Heater (R1)	070-23
3.20	F 34 Door does not lock	070-24
3.21	F 35 Door does not release	070-25
3.22	F 39 Electronic fault (BAE)	070-25
3.23	F 41 Electronic fault (faulty EEPROM / faulty data)	070-26
3.24	F 43 Appliance model is not programmed	070-26
3.25	F 44 Electronic fault (defective connection I <sup>2</sup> C-Bus)	070-27
3.26	F 45 Electronic fault (defective flash RAM/ wrong data)	070-27
3.27	F 46 Display	070-28
3.28	F 47 Electronic fault (defective interface EW/ELP)	070-28
3.29	F 50 Drive	070-29
3.30	F 51 Pressure sensor	070-29
3.31	F 53 Speed meter (tachogenerator)	070-30
3.32	F 56 No spin action	070-31
3.33	F 63 Water path control fault	070-31
3.34	F 92 Bacterial control	070-32
3.35	Residual time keeps changing	070-32
3.36	Maximum spin speed is not reached	070-33
3.37	Water path control (M24) is not activated as programmed	070-33
3.38	Long program running times	070-33
<b>4</b>	<b>Service</b>	<b>070-34</b>
4.1	Programming Overview	070-34
4.2	Programming Overview	070-37
4.3	Demo mode – activate / deactivate	070-41
4.4	Demo mode – activate / deactivate	070-42
4.5	Service mode – Overview	070-43
4.6	Service Mode Overview	070-46
4.7	Control electronic (EW) and Fascia support panel – Remove	070-49

**090 Electrical System**

<b>1</b>	<b>Technical Data</b>	<b>090-2</b>
<b>4</b>	<b>Service</b>	<b>090-3</b>
4.1	Work on the electronic of the frequency converter (ELP)	090-3

## **A Warning and Safety Instructions**

### **1 General**

All repairs should be performed by a trained technician in strict accordance with national, state and local codes. Any repairs or maintenance performed by unqualified personnel could be dangerous.

When servicing, modifying, testing or maintaining appliances, all applicable laws, regulations and accident prevention guidelines must be observed.

Before starting any service work, disconnect the machine from its power source.

Even with the machine switched off, voltage may exist on some components.

Do not work on the washer while it is carrying voltage. If this becomes unavoidable, as in the process of locating faults, put extra safety measures into place.

After work has been completed, as a matter of standard practice, a visual as well as an operational check should be performed.

## 2 Voltage present on power electronic (ELP)

**Danger!**

A capacitor on the power electronic (ELP) maintains voltage of up to approx. 400 V, even after the appliance is disconnected from power.

After the appliance is disconnected from power, an electrical resistor discharges the capacitor within approx. 2 minutes.

Work on the power electronic (ELP) may only be started after it has been established that the capacitor has been safely discharged.



### **3 Sharp edges**

Components may have sharp edges as an outcome of production.

Wear protective gloves and use edge shields (M. no. 05057680) to prevent cuts by sharp-edged components.

## 4 Touch current measurement

**Note**

Touch current measurement should be carried out on all accessible conductive parts that are not connected to ground.

**Warning!**

Touch current measurement should only be carried out after the ground connection of the unit under test has been checked and found to be satisfactory!

Dangerous voltages may exist on defective machines as well as on accessible conductive parts that are not connected to ground!

**Note**

Touch current measurement should be carried out on the following accessible conductive parts:

- Door ring.

## **B Modification History**

<b>When?</b>	<b>Who?</b>	<b>What?</b>
TT.MM.20XX	Olaf Meyer zu Drewer	Creation Version 1 Series start week 34/2006.



## C Technical Data

Dimensions	Height x Width x Depth: 39" x 27" x 30" (990 mm x 685 mm 761 mm)
Weight	130 kg
Washer Dryer Stacked	not planned
Under counter	not planned
Floor mounting	optional, on concrete plinth, mandatory
Stand	optional, accessory
Required voltage and fuses on site	<b>USA:</b> 120 V AC, 60 Hz, 15 A
PC interface	optical
W-LAN interface (IEEE802.11), miele@home	optional, accessory

**Table 1:** Technical data – Large capacity domestic washer front loader (LC HH-WA-FR)



## D Layout of Electrical Components

Fascia – Variations/Optical PC interface

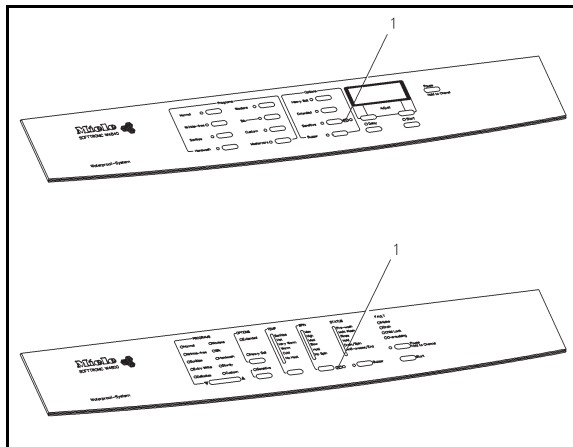

### Layout 1

1 (PC-LED) Optical PC interface

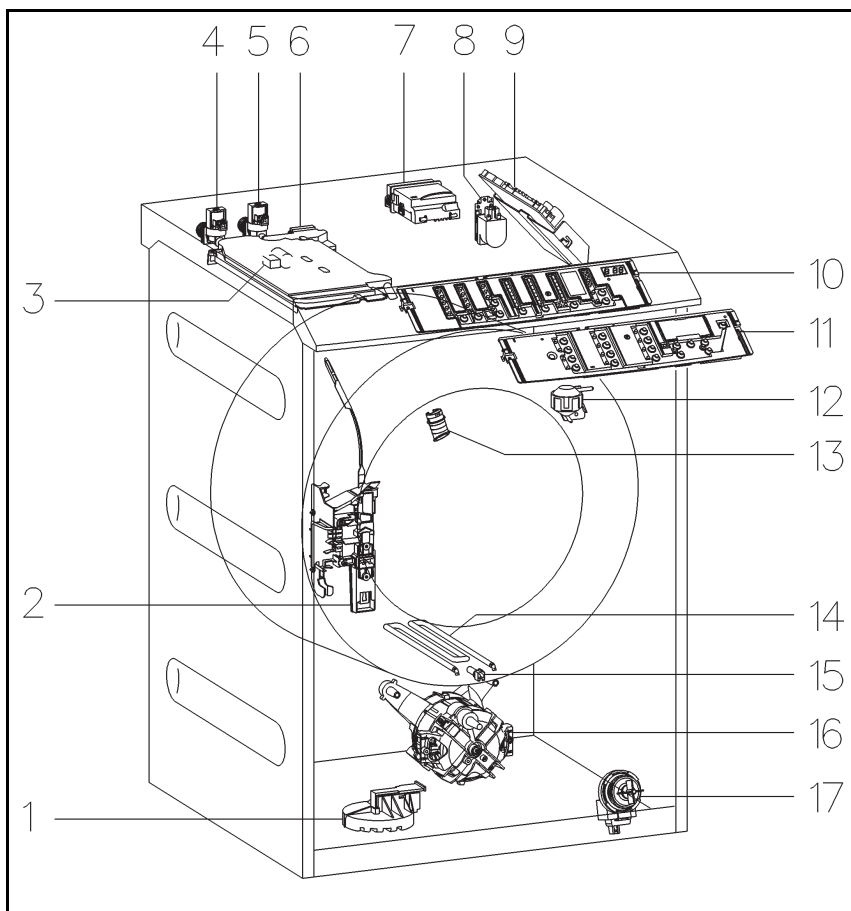

## Layout 2

1 (B8)	Float switch
2 (A2)	Door lock
3 (B3/4)	Flow meter
4 (Y12)	Valve – water intake hot water
5 (Y14)	Valve – water intake cold water
6 (M24)	Motor – water path control unit
7 (WLAN)	Wireless Local Area Network (optional)
8 (Z1)	Interference suppressor
9 (1N1)	Power electronic (ELP)
10–11 (2N1)	Control electronic
12	Druckdose / Pressure sensor
13 (H3/6)	Drum light
14 (R1)	Heater
15 (R30)	Temperature sensor — heater
16 (M5)	Motor – drum drive
17 (M8)	Motor – drain pump (suds pump)



## 010 Housing, Lid, Secure Transport

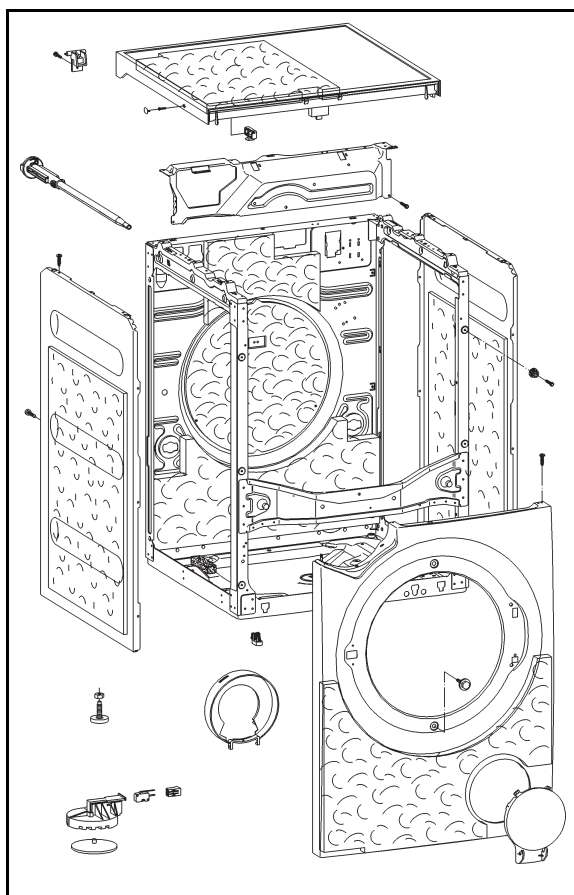

# 1 Technical Data

Design	Frame construction
--------	--------------------

**Table 1:** Technical data – Housing, Lid, Secure Transport

## 3 Fault Repair

### 3.1 Vibrations during spin cycle

#### Cause

The transport struts are still in the appliance.

#### Remedy

✂ Remove the transport struts.

#### Note

To set up and connect the appliance, refer to the operating instructions.

#### Cause

The floor is unstable.

#### Remedy

✂ Set up appliance on a sound floor that can support the appliance.

#### Note

Floors are more stable in the corners of a room than in the middle of a room.

#### Warning!

When setting up on a stand on site, secure the appliance with clamps to keep it from slipping off.

#### Cause

The washer is not installed level.

#### Remedy

✂ Level the washer, adjust feet and counter-lock.

## 4 Service

### 4.1 Lid – Remove

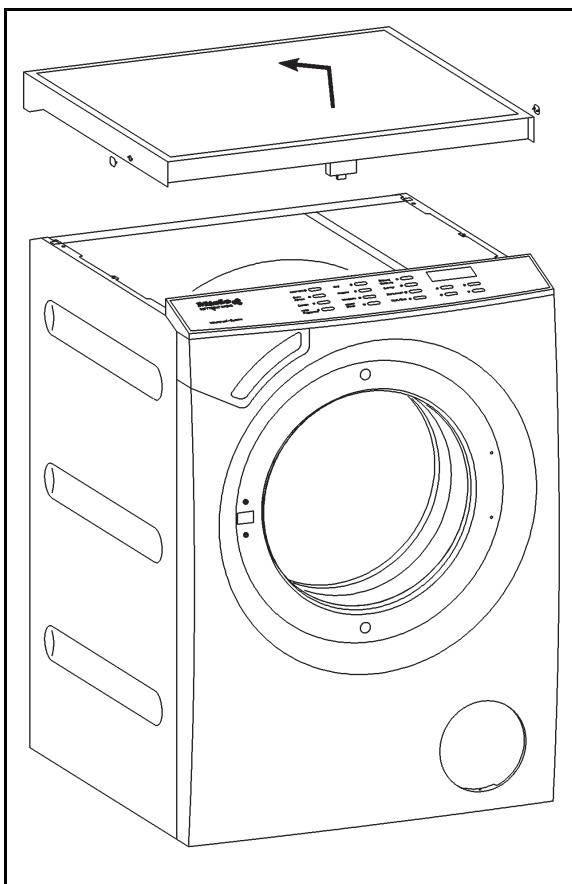

**Fig. 1**

- ✚ Remove the screw caps on the edges.
- ✚ Loosen the raised head screws by a maximum of five turns.

**Note**

Do not remove the raised head screws.

- ✚ Push the raised head screws in.
- ✚ Lift the lid at the front, push it toward the back to release it from its retainers and remove.

## 4.2 Front panel – Remove

- ✂ Remove the appliance lid, refer to Lid – Remove, 010 4.1.
- ✂ Remove the control electronic (EW) and lower fascia panel, refer to Control electronic (EW) and Fascia support panel – Remove, 070 4.7.

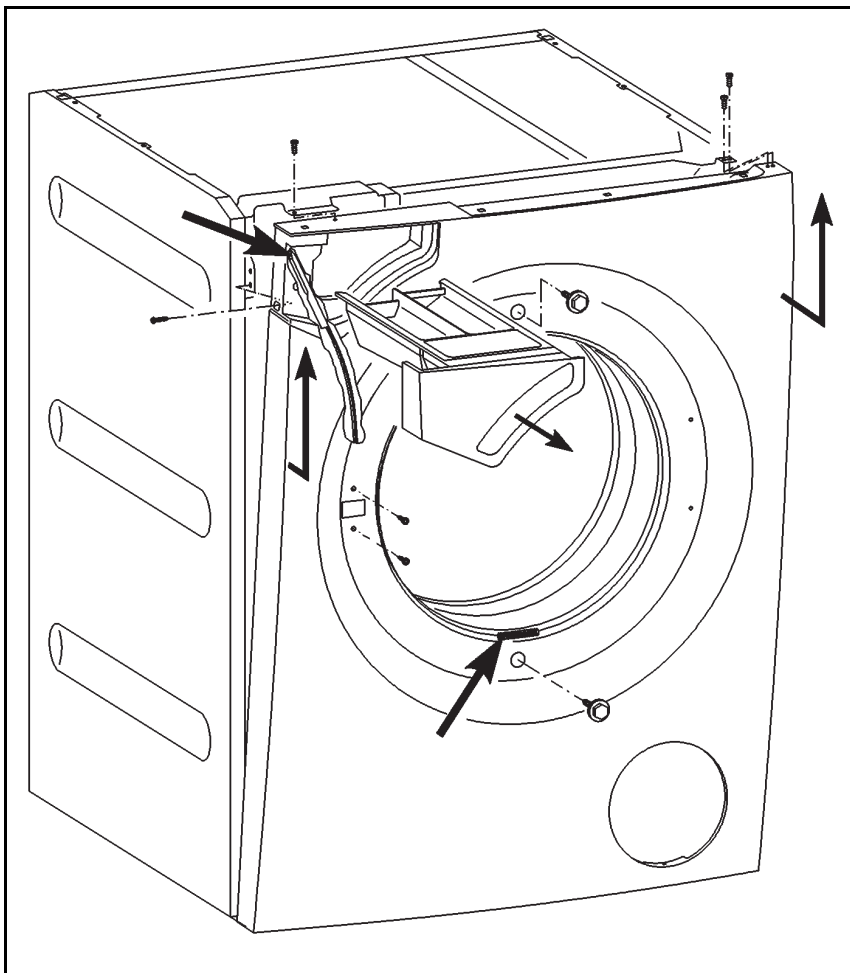

**Fig. 2**

- ✂ Remove the door lock retaining screws.
- ✂ Remove the seal clamping ring.
- ✂ Loosen the door seal ring from the front panel.
- ✂ Loosen the attachment of the front panel above and below the fill hole.
- ✂ Loosen the attachment of the front panel at the detergent drawer and at the top on the right side.
- ✂ Tilt the front panel forward at the top and lift it off.
- ✂ **Installation:** Hook the manual release latch into the detergent drawer.

### 4.3 Float switch (B8)

**Danger!**

Risk of electric shock when working on low-voltage components.

In the power electronic, there is no galvanic isolation from the power supply.

When working on a washer connected to the power supply, be aware of the risk of mains potential on low-voltage components.

## 020 Door, Magnet, Lock

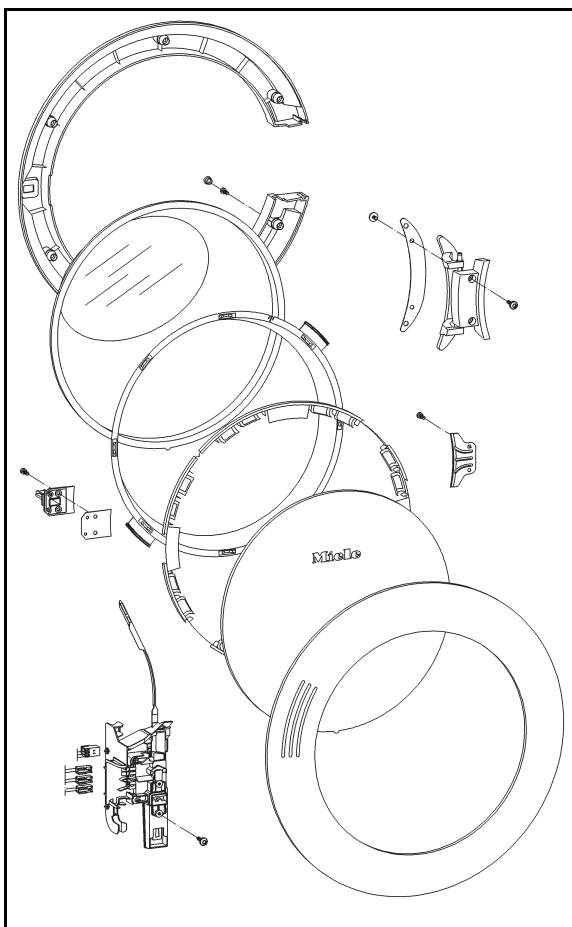

# 1 Technical Data

Special tools	
Locking latch	To run the appliance in the service department programming/service mode, with the front panel removed
Porthole	To run the appliance in the service department programming/service mode, with the front panel removed

**Table 1:** Door, Magnet, Lock – Special tools



## 2 Function

### 2.1 Pull door lock (A2)

#### 2.1.1 Electromagnetic door lock

When locking the door, the locking latch dips into the lock and is pulled into the lock by the locking mechanism.

The power electronic (ELP) registers the locked state via a switch in the door lock (A2).

During operation, with the door closed, the door lock is electromagnetically bolted, refer to 020 2.1.2 Safety requirements.

As long as the door is not electromagnetically bolted, the door can be opened by simply pulling it.

Activating the emergency release cancels the electromagnetic lock, and the door can be opened.

#### **Danger!**

Opening the door by means of the emergency release may present danger of injury by a rotating drum, danger of scalding suds and flooding.

#### **Note**

Closing the door when the door lock is already locked causes damage to the door lock.

If the door lock is locked, with the door open, it has to be released manually, refer to Door lock (A2) – Open manually, 020 4.1.

#### 2.1.2 Safety requirements

After pressing the “Start” pad, the electromechanical door lock is only activated when the following safety requirements are met:

- Drum speed  $< 7 \text{ min}^{-1}$ , registered by RPM sensor (Tachogenerator),
- Water level  $< 80 \text{ mmWS}$ , registered by analog pressure sensor (ADS),
- Suds temperature  $< 131 \text{ }^\circ\text{F}$  ( $55 \text{ }^\circ\text{C}$ ), registered by suds temperature sensor (NTC resistor R30).

### **3 Fault Repair**

#### **3.1 Door lock (A2) does not lock**

##### **Symptom**

The door latch hits the locking mechanism when pushing into the door lock (A2).

##### **Cause**

The locking mechanism is locked, with the door open.

##### **Remedy**

- ↻ Open the door lock (A2) manually, refer to Door lock (A2) – Open manually, 020 4.1.
- ↻ Check the function of the door lock (A2).

## 4 Service

### 4.1 Door lock (A2) – Open manually

**Note**

Manual opening is only required when the door locking mechanism is locked, with the door open.

This happens if the locking mechanism is interfered with, e.g. if an object is pushed into it.

In this situation, the locking latch cannot push into the lock and the door can't be closed.

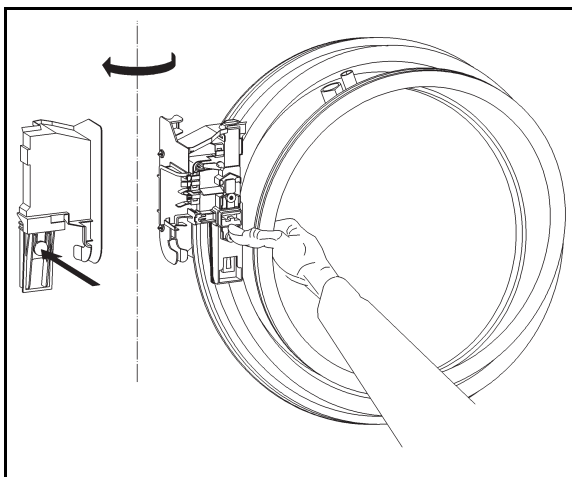
**Fig. 1**

- ✎ With the front panel in place, the door lock (A2) and the door seal fitted, press the door locking mechanism open.

## 4.2 Door lock (A2) – Remove

✎ Remove the front panel, refer to Front panel – Remove, 010 4.2.

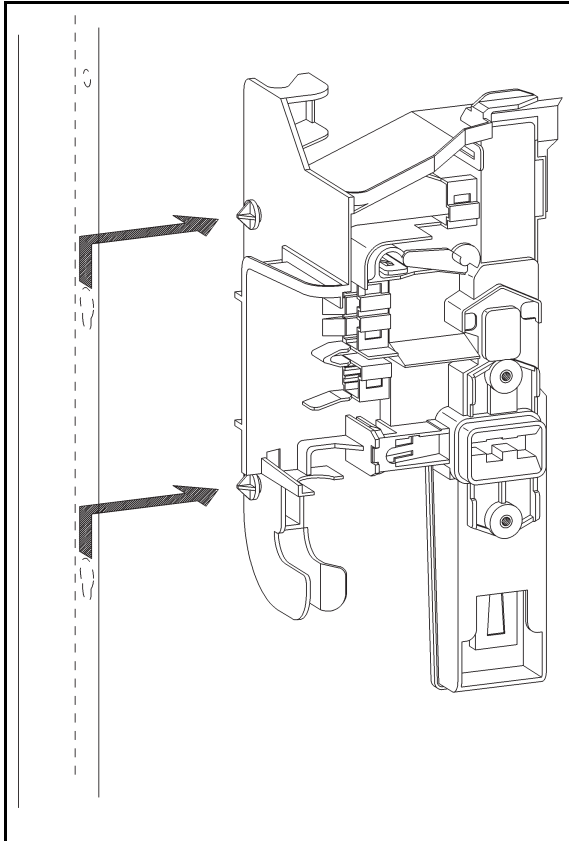
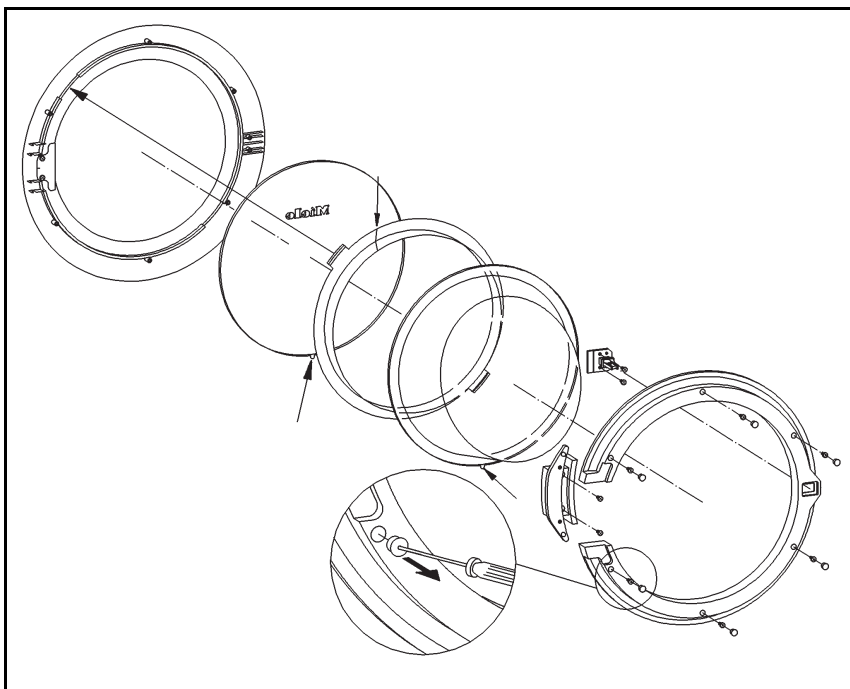

**Fig. 2**

✎ Lift the door lock (A2) and remove.

✎ Pull the plug off.

### 4.3 Door porthole, door latch and hinge – Remove



**Fig. 3**

**Note**

The plugs in the door ring are destroyed during dismantling and have to be replaced when reassembling the door.

Do not damage the porthole ring when removing the plugs.

- ✂ Use a pointed tool to remove the plugs on the porthole ring.
- ✂ Remove the retaining screws.



## 030 Suds container, Drum, Bearing, Heater element

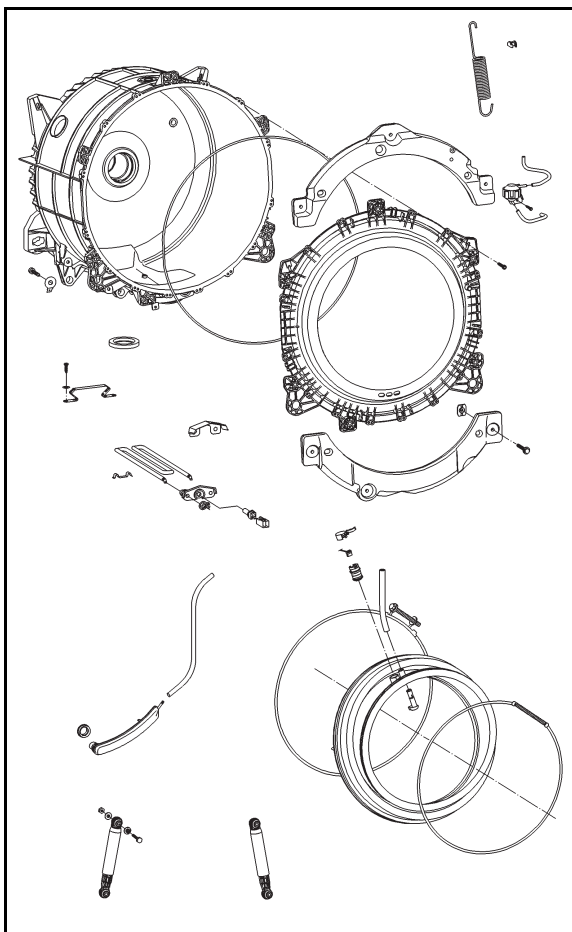

# 1 Technical Data

Suds container	Moving component	Non-metal suds container, drum incline 8 °
	Drum	Honeycomb drum
	Drum diameter	19" (480 mm)
	Capacity, dry laundry	8 kg
	Drum volume	21 gal (80 l)
	Fill hole	15 3/4" (400 mm)
	Drum light	LED 3.4 V /1 W

**Table 1:** Technical data — Suds container, Drum, Bearing, Heater element

Temperature (°F)	Resistance (kΩ)
32	38.0
41	29.7
50	23.4
59	18.6
68	14.9
77	12.0
86	9.73
95	7.96
104	6.55
113	5.42
122	4.52
131	3.78
140	3.19
149	2.70
158	2.29
167	1.96
176	1.68
185	1.45
194	1.25
199	1.15
203	1.09
212	1.06

**Table 2:** Suds temperature sensor (R30) - Resistance values (NTC)



## **2 Function**

### **2.1 Foam sensing**

#### **2.1.1 Foam when heating during the main wash cycle**

Heating the suds generates foam, and as foam pushes into the vents, the pressure increases in the suds container.

If the analog pressure sensor registers a pressure increase of 60 mm wc above wash level during heating, then

- the heater is switched off for 2 minutes. It will only be switched on again when the pressure increase drops to 15 mm wc above wash level; no fault message for target temperature not reached is issued,
- if foam sensing occurs three times, the fault message “Check dosage” is issued at program end,
- if foam sensing occurs three times, the fault message “F 16 excess foam dosage” is saved, refer to F 16 Oversudsing, 070 3.17.

#### **2.1.2 Foam at rinse cycle water intake (in the drum vent or in the siphon)**

If foam is generated during rinsing, the pressure in the suds container rises faster than it would based on the water intake.

If the analog pressure sensor registers a pressure increase of more than 40 mm wc within 4 s during water intake, then

- the water intake is interrupted for at least 15 seconds,
- the water intake will only continue when the pressure increase drops to 15 mm wc,
- the fault message “Check dosage” is issued at program end,
- the fault message “F 16 excess foam dosage” is saved, refer to F 16 Oversudsing, 070 3.17.

#### **2.1.3 Foam during spin cycle (water sheet)**

The spin cycle generates foam, and a water sheet is formed. The pressure increases, and the water sheet acts as a brake on the drum.

If the pressure sensor registers a higher pressure than standard for a spin speed during a spin cycle, or if the target/actual speed difference is higher than expected, then

- the RPMs are reduced, or the spin cycle is stopped,
- an additional rinse cycle is carried out if the spin cycle did not go for at least 60 seconds at 700 RPM.

- the fault message “Check dosage” is issued at program end,
- the fault message “F 16 excess foam dosage” is saved, refer to F 16 Oversudsing, 070 3.17.

## **2.2 Light in the door concertina seal**

LED lamp in the concertina seal.

## **2.3 Heater**

### **Thermal cut-out:**

To protect the appliance from overheating in the case of a technical malfunction, e. g. if a heater relay is “stuck”, the heater element is equipped with an integrated thermal cut-out.

If the thermal cut-out trips, the heater element is destroyed.

## 4 Service

### 4.1 Temperature sensor (NTC resistor, R30)

**Danger!**

Risk of electric shock when working on low-voltage components.

In the power electronic (ELP), there is no galvanic isolation from the power supply.

When working on a washer connected to the power supply, be aware of the risk of mains potential on low-voltage components.

### 4.2 Air trap – Clean

✂ Remove the front panel, refer to Front panel – Remove, 010 4.2.

### 4.3 Door sealing ring – Replace

✂ Remove the front panel, refer to Front panel – Remove, 010 4.2.

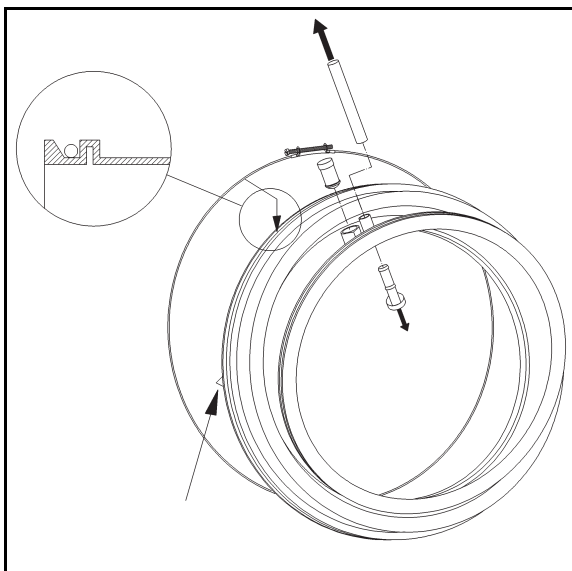
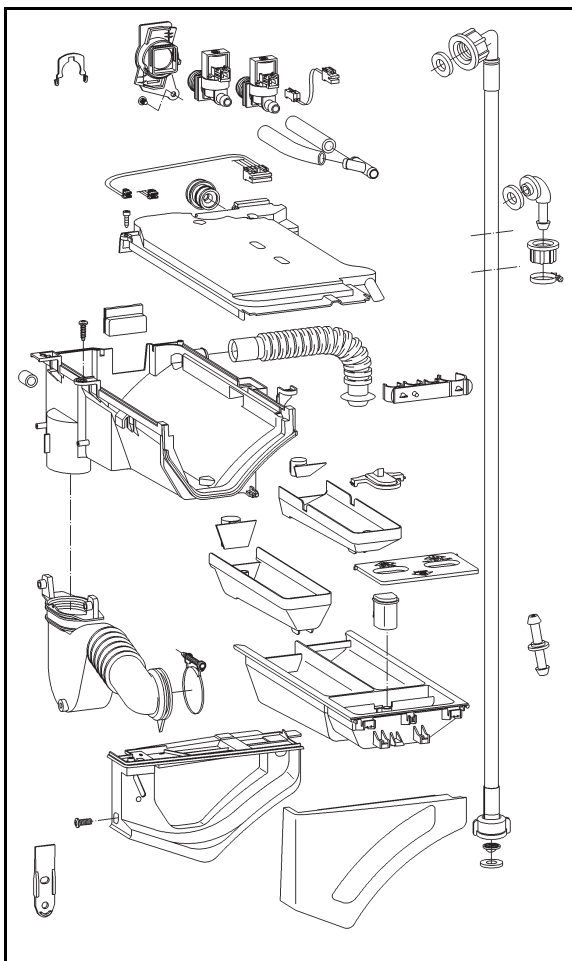

**Fig. 1**

- ✂ Loosen the hose clip at the sealing ring and remove the hose clip.
- ✂ Remove the cap from the lamp, pull the plug off and remove the lamp.
- ✂ Pull the nozzle from the connecting hose, press the nozzle out of the sealing ring.
- ✂ **Installation:** Door sealing ring marker at 9 o'clock.



## 040 Water intake



## 1 Technical Data

Water intake	5-line water path control unit (M24) and 4-compartment detergent drawer
	Volume counter / Flow meter (B3/4)
	Cold water connection: Solenoid valve
	<b>USA:</b> Hot water connection: Solenoid valve with Y-connecting hose to volume counter / Flow meter (B3/4)
	Water control system (WCS) or Waterproof (WPS)

**Table 1:** Technical data – water intake

## 2 Function

### 2.1 Float switch (B8)

A float switch (B8) is located in the sump of the appliance housing.

If water leaks into the sump, float switch (B8) is activated.

The program and with it the water intake are stopped, and the fault message **Waterproof** is issued.

### 2.2 Hot water intake control

The hot water intake starts from a temperature selection of

- **USA:**  $\geq 86^{\circ}\text{F}$  ( $30^{\circ}\text{C}$ ),
- **Europe:**  $> 95^{\circ}\text{F}$  ( $35^{\circ}\text{C}$ ),

in all wash programs except woolens, silk and hand wash.

### 2.3 Automatic load control / Intelligent water intake (IWE)

Automatic load control matches the incoming water amount to the amount of laundry.

Automatic load control is the outcome of intelligent water intake (IWE). An analog pressure sensor monitors the water intake. The control measures the absorbency rate of the laundry after the first and second water intake, the pressure drop rates, the spin speed variance and the water amount taken in.

Based on this input, the laundry load and type of laundry are calculated.

Depending on program, the following parameters are adjusted:

- Water level,
- Wash duration (incl. correction of residual time),
- Number of additional heating cycles,
- Number of rinses,
- Water level in the rinse cycles,
- Rinse duration,
- Final spin speed.

## 2.4 Water intake monitoring – water control system (WCS)

Water intake monitoring will register a shut off faucet, too low water pressure, or a seal problem, such as a missing lint filter.

If a fault occurs, the program is stopped and the fault message **water intake fault** is displayed.

A **water intake fault** is issued under the following conditions,

- if after **5 seconds** water intake the **flow meter (B3/4)** does not register a signal,
- if after **150 seconds** water intake the **analog pressure sensor (ADS)** does not register an increase of at least **8 mm wc**,
- if the **flow meter (B3/4)** registers **15 liter** water intake and the water pressure as measured by the **analog pressure sensor (ADS)** did not increase to at least **20 mm wc**.

Or if the water volume in one block rises above a critical threshold.

**Hot water only:** When the program option **hot water** intake is selected, the fault is **not saved** and the program which is running is continued with cold water.

## 2.5 Water overflow monitoring

If the overflow level of 10" wc is reached, the drain pump (M8) runs until the level drops by 3" down to 7" wc.

## 2.6 Flow meter (B3/4)

The flow meter (B3/4) is integrated into the water path control unit.

The flow meter (B3/4) generates impulses depending on the water flow.

Based on these impulses, the electronic calculates the amount of water that has run into the suds container.

### Advantages:

- The flow meter registers the amounts of water flowing in more accurately, compared to previous systems without this sensor.

The analog pressure sensor (ADS) monitors the function of the flow meter.

During a malfunction or total failure of the flow meter, the water intake is controlled via level-controlled fill.



**2.7 Water path control unit, motor water path control unit (M24)**

Activation by electrical motor. Measurements are taken via a slip contact in the water path control unit.

Water path control unit with an additional fifth position for bleach.

## 4 Service

### 4.1 Flow meter (B3/4)

**Danger!**

Risk of electric shock when working on low-voltage components.

In the power electronic, there is no galvanic isolation from the power supply.

When working on a washer connected to the power supply, be aware of the risk of mains potential on low-voltage components.

## 050 Water drain

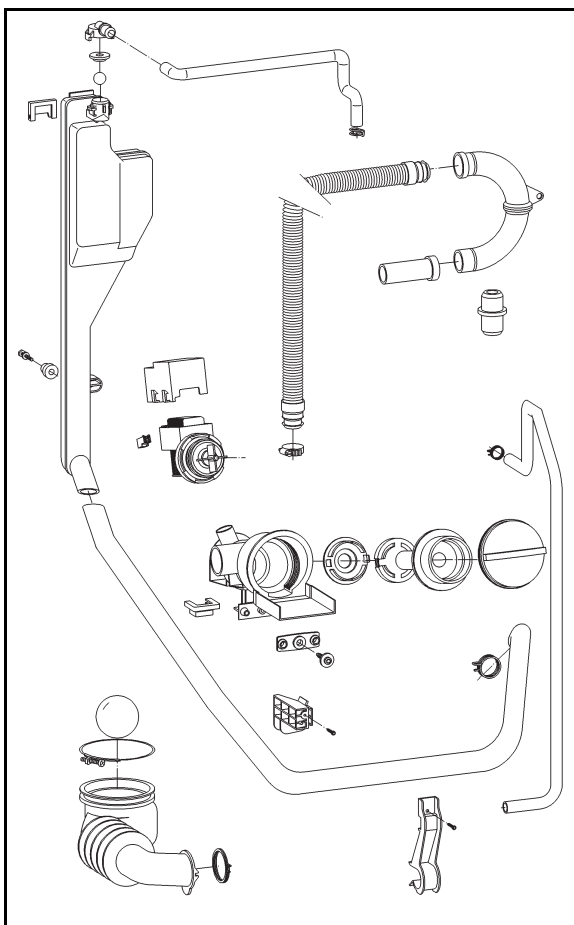

# 1 Technical Data

Drain pump	Synchronized pump/motorized drain pump (M8)
	Max. head height 3', max. drain hose length 16' 5"

**Table 1:** Technical data – Water intake

## 2 Function

### 2.1 Water drain monitoring

With the drain pump activated, the water level is monitored to check if it has dropped to 2" wc after 150 seconds; if the level has not dropped accordingly, the program is stopped, and the fault message **water drain fault** is displayed.



## 060 Drive

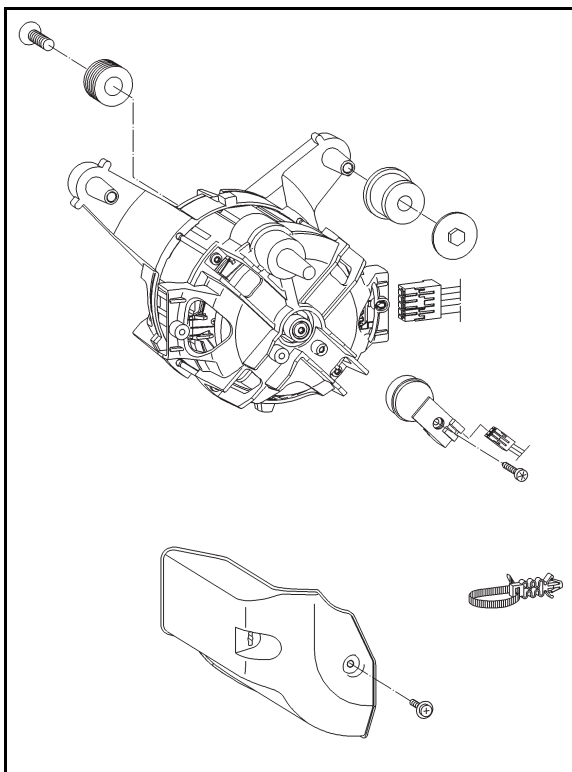

# 1 Technical Data

Motor drum drive (M5)	Commutator-free 3-phase asynchronous motor MXT 40. Toothed V-belt.
RPM monitoring	16-pole tachogenerator
Guide	Frequency converter (FU) integrated in power electronic program (ELP).

**Table 1:** Technical data – Drive

<b>Special tool</b>	<b>Mxt 40</b>
Assembly lever for toothed V-belt	M. no. 05057690

**Table 2:** Drive special tools



## 2 Function

### 2.1 Spin lock

Prior to the first commissioning, a lock is placed on the spin cycle.

This is to prevent that the appliance is damaged or people are endangered, if for example the spin cycle is accidentally activated while the appliance is on display, with the struts mounted, or with an accessories kit stored in the drum.

The spin lock is in effect until the first water intake of 35 mm wc.

**Note**

The spin lock is also in effect for the customer service mode.

### 2.2 Toothed V-belt

The toothed V-belt is elastic.

The toothed V-belt tension is the result of the fixed, non-adjustable distance between the motor and the flywheel.

### 2.3 Motor overheating protection

The motor winding has a temperature limiter (Klixon) built in.

At increased winding temperature, the temperature limiter opens the switching contact.

When the switching contact is open, the power electronic (ELP) switches the motor off.

When the temperature drops to a normal level, the contact closes again.

## 2.4 Tachogenerator

A generator attached to the motor produces alternating voltage and frequency depending on motor speed.

The power electronic (ELP) calculates a spin speed signal from the AC frequency.

Fault code, refer to F 53 Speed meter (tachogenerator), 070 3.31.

### **3      **Fault Repair****

#### **3.1      **Drum drive defective****

**Cause**

Defective drive

**Check drive**

↷ Check drive MXT 40, refer to Drive MXT 40, 060 4.3

## 4 Service

### 4.1 Tachogenerator

**Danger!**

Risk of electric shock when working on low-voltage components.

In the power electronic (ELP), there is no galvanic isolation from the power supply.

When working on a washer connected to the power supply, be aware of the risk of mains potential on low-voltage components.

### 4.2 Toothed V-belt – Mount

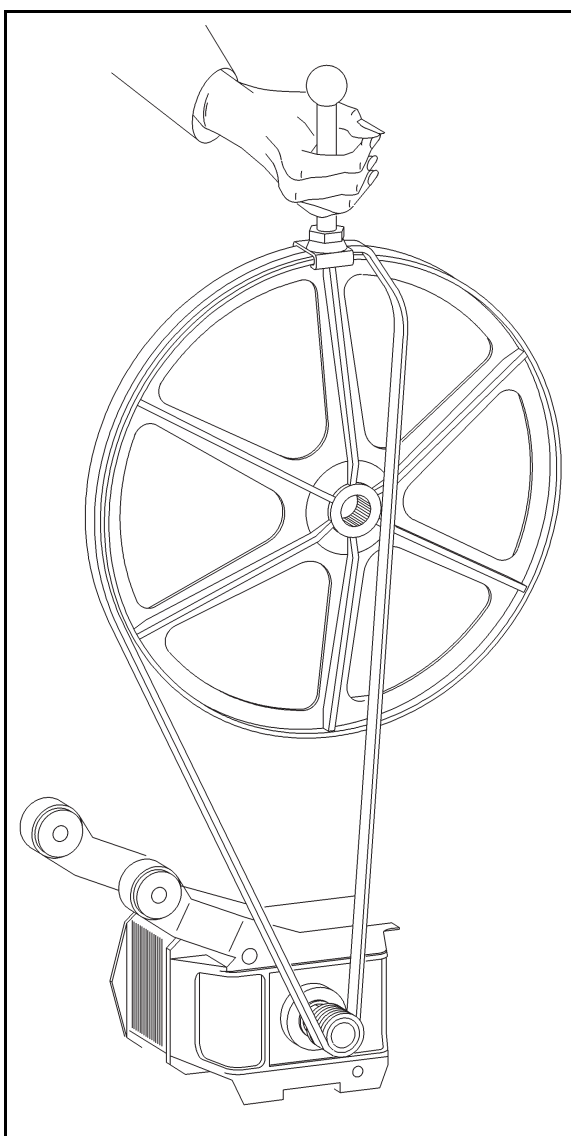

**Fig. 1:** Mount the front loader toothed V-belt

- ✎ Fit the toothed V-belt onto the pulley with the aid of a mounting lever, M. no. 05057690.

### 4.3 Drive MXT 40

- ✎ Check drum and drive for free movement. If the drive is blocked, remove the toothed V-belt and check the drum and drive motor for free movement.
- ✎ Check the motor winding temperature limiter (Klixon): Pull the plug off the motor. Check the motor winding temperature limiter (Klixon) for continuity, open circuit and short circuit.
- ✎ Check the motor winding: Measure the electrical resistance of the motor windings. The target value for the resistance of the motor windings, measured between the plugs, at a room temperature of 68 °F (20 °C):  $7 \Omega \pm 1 \Omega$  (at higher temperatures the resistance can increase by 150 %). Permissible difference between single measurements:  $< 0.5 \Omega$ . Target value of measurement of windings to motor chassis/ground:  $\infty \Omega$  (Isolation).
- ✎ Check for ground: Check motor chassis: Measure the electrical resistance between the plug ground pin and the motor chassis. Target value for the ground connection: Continuity.
- ✎ Motor wiring harness defective: Check the motor wiring harness and motor plug visually for damage, check the wiring harness cables for continuity, open circuit and short circuit. If a fault occurs sporadically, move the wiring harness during the measurement.
- ✎ Check the speed sensor (Tachogenerator):

#### **Danger!**

Risk of electric shock when working on low-voltage components.

In the power electronic (ELP), there is no galvanic isolation from the power supply.

When working on a washer connected to the power supply, be aware of the risk of mains potential on low-voltage components.

#### **Note**

The wiring diagram shows the pin allocation of the motor plug.

Target values given apply to measurements at a room temperature of 68 °F (20 °C).

- ✎ Turn the motor/drum vigorously and measure the voltage at the tachogenerator. Target value for the alternating voltage at the tachogenerator: Approx. 1-3 V. Check the tachogenerator for short circuit against the motor chassis. Check that the magnet is fastened to the motor shaft.



## 070 Fascia panel, Control electronic

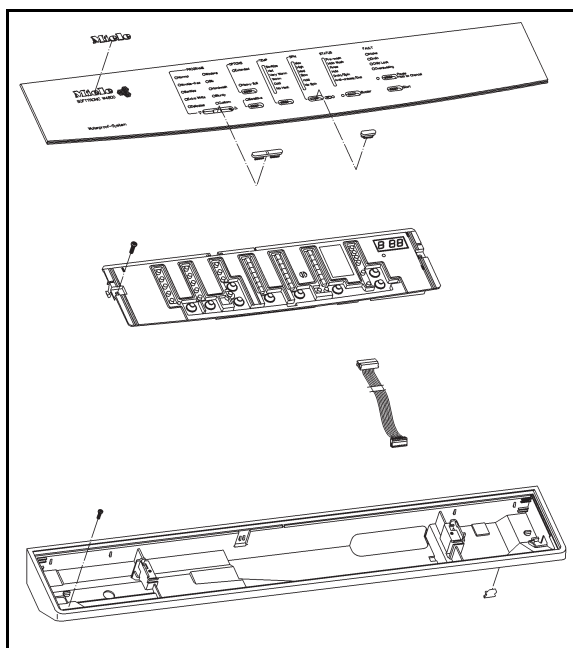

# 1 Technical Data

Control technology	Electronics	Program electronic: Novo IV basic controls with keypads: EW 100–UPower electronic ELP 255 with integrated frequency converterControl electronic Novotronic IV. Update capable via PC optical interface.	
Wireless Local Area Network (WLAN)	WLAN ready		
Wash technology	Process technology	Hydromatic IV E, saved in ELP Program update capable	
	Current volume meter	Flow meter (B3/4)	
	Level monitor	Analog pressure sensor (ADS) integrated in the power electronic (ELP)	
	Heater (R1)	Electrical heater	
	Suds temperature sensor (R30)	NTC	
	Rinse sensor	<b>Not USA/CDN:</b> The temperature sensor (heater) (R30) serves as rinse sensor at the same time	
	Imbalance sensor		RPM imbalance sensor
			<b>EU:</b> Imbalance sensor or optional path sensor (Load sensor, B1/15)

**Table 1:** Technical data – Fascia panel, Control electronic



## 2 Function

### 2.1 Child safety sensor

If a living creature should be in the drum, the program sequence needs to be interrupted and the door released electronically, so that in this emergency, it can be pushed open from the inside.

**Note**

The door can only be pushed open from the inside, or pulled open from the outside, as long as it is not electronically bolted.

After the program start, until the motor is activated, the control monitors the movements of the drum via the RPM sensor (Tachogenerator).

If a living creature should be in the drum and it **moves**, this can be detected through the movement sensor. The program is interrupted for 15 minutes. If movement is sensed again, the program is stopped.

**Note**

During water intake, the tumbling laundry can cause drum movements. This can activate the child safety sensor.

Press "Start" to continue the program.

### 2.2 Action after a power failure

The appliance automatically continues the program at the exact point where it stopped when the power cut out.

## 2.3 Programming function (HY IV E)

### 2.3.1 Water Plus

Setting for **Water Plus**.

When **Water Plus** is selected, the water level is raised and/or an additional rinse cycle is carried out.

### 2.3.2 Gentle cycle

Setting for gentle cycle.

Selecting the gentle cycle reduces the drum movement. Fabrics are washed gently.

For lightly soiled laundry.

### 2.3.3 Suds cooling

At active suds cooling, in programs 167°F and higher, cold water is taken in at the end of the main wash cycle to cool the suds down.

This reduces the danger of scalding by draining suds, and it protects drain pipes that are not high temperature resistant.

### 2.3.4 Memory

At active memory function, the **program settings** made at the start of a program and the special settings, such as temperature and spin speed, are saved. When the same program is selected again, these special settings are automatically activated.

### 2.3.5 Buzzer

Activate the buzzer to sound at program end and during rinse stop, and set the buzzer tone.

#### Note

In case of a fault, the buzzer also sounds even if it has not been activated.

### 2.3.6 Language

The active language is used for the operating, programming and service modes.

### 2.3.7 Contrast

The contrast of the display can be adjusted to suit the existing lighting conditions.

Set display, refer to Display.

**2.3.8 Standby**

When the standby function is activated, the display dims after 10 minutes, to reduce energy consumption.

If the option **not during a running program** is selected, the standby function only acts before and after a program cycle, not during a running program.

**2.3.9 Water intake**

Activation of hot water valve (Y12 / 2Y40).

Customization of the water intake control and the laundry process.

**2.3.10 Max. water level**

Adjustment of the laundry process for soft water areas.

Level III at rinse cycle.

**2.3.11 Country version**

Adjustment of the laundry process depending on the country of destination.

**2.3.12 Max. spin speed**

Adjustment of the final spin speed.

**2.3.13 Load automatic**

For detergent test facilities only.

Activate / deactivate intelligent water intake (IWE).

**2.3.14 Imbalance values**

Adjustment of the imbalance thresholds.

**2.3.15 Central unit**

Function data not available at this time.

**2.3.16 Heater output**

The heater output influences the wash cycle time/residual time indication.

**2.3.17 Low water pressure**

If the flow pressure is lower than 1 bar, the water intake monitor – water control system (WCS) registers this as a fault, refer to 040 2.4 Water intake monitoring – water control system (WCS).

If the water pressure cannot be increased on site, this program function allows the adjustment of the water intake monitor in line with the low water pressure.

### 2.3.18 Allergy

**Note**

Function data not available at this time.

When the program function allergy is activated, the technical process provides an optimum adaptation to the needs of allergy sufferers:

- additional rinse cycles,
- higher water levels,
- additional spin for suds extraction,
- speed of spin for suds extraction,
- rinse to clear foam remnants from porthole.

### 2.3.19 Sensor controlled rinse cycle

During the rinse cycle, cold rinse water drenches the laundry and mixes with the warm suds in the laundry, which increases the temperature of the rinse water.

The increase in temperature is monitored by the suds temperature sensor NTC (R30).

The temperature increase provides an indication of the rinse effectiveness.

This program function activates/deactivates the sensor monitored rinse process.

### 2.3.20 Temperature

Set the temperature format in the display to Celsius (°C) or Fahrenheit (°F).

### 2.3.21 Current volume meter (VSZ)

Current volume meter (VSZ) = Flow meter (B3/4).

Technical adaptation and fault monitoring.

Optional, integrated into the water path control, refer to 040 2.6 Flow meter (B3/4).

### 2.3.22 Keypad tone

To activate the keypad tone acknowledgment.

### 2.3.23 Reset

All programming options are reset to delivery status.

**Note**

The reset is effective immediately, restoring the previous settings is not possible!  
Operating hours are not reset.  
Not possible with customer service electronic devices.

**2.3.24 Imbalance sensor**

Adaptation of the imbalance and load calculation to existing sensors:

- speed sensor (Tachogenerator),
- imbalance sensor,
- load sensor.

**Note**

The programming option load sensor has to be activated for the load sensor to display.

**2.3.25 Water valves**

Activation and fault monitoring of the water valves or water path control unit with 4 or 5 paths.

**Note**

Frontloaders, without chlorine bleach option, are equipped with a 4-position water path control unit (M24).

Frontloaders with chlorine bleach option are equipped with a water path control unit (M24) with an additional 5th position.

Refer to Appliance, Technical Data and Wiring Diagram.

**2.3.26 Display**

W 4800

Fascia panel with/without 7 segment display.

**2.3.27 Appliance**

The features required to control and monitor the housing lid, lid II and positioning are deactivated.

**2.3.28 Load indication****W 4800**

To activate the display for load and dispensing.

**Note**

Prerequisite for the load indication is also the setting of load sensing in the programming function for the imbalance sensor.

**2.3.29 Drum light**

To activate/deactivate the drum light and fault monitoring.

**2.3.30 Brightness**

The brightness of the display can be adjusted to suit the existing lighting conditions.

Display brightness, refer to Display.

**2.3.31 Fascia panel type****W 4800**

The different features are:

- Front-/Toploader,
- Load amount,
- Extras Short/Intensive,
- Extras that can be selected in special programs.

**2.3.32 Hygiene****W 4840**

If laundry is run continually at low temperatures, bacteria can start to form in the washer.

A counter keeps track of the number of programs that are washed at a target temperature of  $\leq 104^{\circ}\text{F}$  ( $40^{\circ}\text{C}$ ).

After a certain number, the prompt appears to run a program at a target temperature of  $\geq 140^{\circ}\text{F}$  ( $60^{\circ}\text{C}$ ).

After the wash program at  $\geq 140^{\circ}\text{F}$ , the counter resets to 0.

**Note**

The program function Hygiene has to be activated for this intervention, refer to F 92 Bacterial control, 070 3.34.

**2.3.33 Prewash at heavy soil**

W 4800

With or without prewash when **Heavy soil** is selected.

**2.3.34 Chlorine / Bleach agent intake**

W 4840

To activate the chlorine / bleach agent intake.

Set the water path control for chlorine / bleach agent intake.

**2.4 Service function****2.4.1 Component test**

Activate electronic components.

Check the function visually, acoustically, and by observing the display.

**2.4.2 Sensor test**

Sensor signals are indicated.

Check the function visually, acoustically, and by observing the display.

So that all sensor functions can be checked, change test conditions manually, moving from one test segment to another.

**2.4.3 Operating hours meter**

Time is counted from program start, not included are delay start and anti-crease.

The time is stored in the electronic power program (ELP).

**2.4.4 Operating**

Operating functions are indicated.

Check the function visually, acoustically, and by observing the display.

So that all operating functions can be checked, change test conditions manually, for example by pressing keypads.

## **2.5 Demo mode**

### **2.5.1 Demo program mode**

Display and LEDs are activated automatically for demonstration.

Electronic components are not switched on.

To activate/deactivate the demo program mode, refer to Demo mode – activate / deactivate, 070 4.3, Demo mode – activate / deactivate, 070 4.4.

### **2.5.2 Demo program mode (program simulation)**

The unit can be operated.

Electronic components are not switched on.

Only the LEDs and display indicators light up as in the operating mode.

To activate/deactivate the demo program mode, refer to Demo mode – activate / deactivate, 070 4.3, Demo mode – activate / deactivate, 070 4.4.

## **2.6 Fault dialogue**

The power electronic (ELP) monitors the electronic sensors.

If the power electronic (ELP) registers a fault, it sends a fault message to the control electronic (EW).

The control electronic (EW) shows the fault message in the display.

Technical faults are saved by the power electronic (ELP).

If the communication between the power electronic (ELP) and the control electronic (EW) is defective, the EW sends the message independently that a fault has occurred.



## **3 Fault Repair**

### **3.1 All LEDs flash**

#### **Symptom**

It's not possible to start a program, it's not possible to access the programming or service mode.

#### **Cause**

The appliance is in demo mode.

#### **Remedy**

↯ Deactivate the demo mode, refer to Demo mode – activate / deactivate, 070 4.3, Demo mode – activate / deactivate, 070 4.4.

### **3.2 LED Start flashes rapidly**

#### **Symptom**

The drain pump (M8) is switched on for up to one hour, depending on level.

The buzzer sounds, independent of setting, intermittently for two minutes.

Sevensegment display “- - -”.

#### **Cause**

Technical fault

#### **Remedy**

↯ In service mode, read the fault code, refer to Service mode – Overview, 070 4.5, Service Mode Overview, 070 4.6.

### 3.3 **Sevenssegment display: “- - -”**

#### **Symptom**

The drain pump (M8) is switched on for up to one hour, depending on level.

The buzzer sounds, independent of setting, intermittently for two minutes.

The Start LED flashes rapidly.

#### **Cause**

Technical fault

#### **Remedy**

✍ In service mode, read the fault code, refer to Service mode – Overview, 070 4.5, Service Mode Overview, 070 4.6.

### 3.4 **Display indicates: Program is locked**

#### **Cause**

The electronic child safety lock is switched on.

**Deactivate the electronic child safety lock.**

#### **Note**

Refer to the operating instructions to activate/deactivate the electronic child safety lock.

✍ Press keypad 6 Prewash, the display shows the program release.

#### **Note**

The control dial has to be positioned at the locked program.

### 3.5 Display indicates: Appliance is locked

#### Symptom

Electromechanical door lock. The door cannot be opened by means of the switch/ the door/the lid (S4).

#### Cause

During a program cycle, the door is bolted for safety reasons.

#### Remedy

↻ End the program.

#### Note

Electromechanical door lock, refer to 020 2.1 Pull door lock (A2).

#### Cause

Suds in the suds container.

#### Remedy

↻ Activate the program "pump".

#### Cause

Defective drainage.

#### Remedy

↻ Check the drain pump (M8) and drain.

#### Cause

Defective water level sensing.

#### Remedy

↻ Check the analog pressure sensor (ADS).

### 3.6 Display indicates: Locked, enter code

#### Symptom

It's not possible to select a program.

#### Cause

The electronic lock function is activated.

#### Remedy

##### Note

Electronic lock function – refer to the operating instructions.

- ✍ **Release the lock to select a program cycle:** Enter code 125.
- ✍ **Deactivate the lock:** Select program function “lock” and enter code 125, refer to Programming Overview, 070 4.1, Programming Overview, 070 4.2.

##### Note

Enter the number and confirm: Select the digits by pressing the pad + / - , and confirm with the OK pad.

### 3.7 Display indicates: No start. Demo mode activated

#### Symptom

It's not possible to start a program.

#### Cause

Demo mode is activated.

#### Remedy

- ✍ To deactivate the demo mode, refer to Demo mode – activate / deactivate, 070 4.3, Demo mode – activate / deactivate, 070 4.4.

### **3.8 Display indicates: Waterproof, shut off faucet**

#### **Symptom**

In the operating mode, the display shows: Waterproof reaction.

The LED "check water intake" and the LED "check water drain" flashes rapidly.

The program is stopped, the water intake valve is closed, and the drain pump is switched on for 120 seconds.

Waterproof system (WPS), refer to 040 2.1 Float switch (B8).

#### **Cause**

The appliance has a leak, there is water in the sump pan, and the float switch (B8) has responded.

#### **Remedy**

- ✚ Shut off the water faucet.
- ✚ Remove the water from the sump/drain pan.
- ✚ Locate the leak and fix it.

### **3.9 Display indicates: Water drain fault, check drain**

#### **Cause**

Water drain is insufficient.

#### **Remedy**

- ✚ refer to F 11 Water drain, 070 3.15

### 3.10 Display indicates: Technical fault

#### Symptom

In the operating mode, the display shows: Technical fault.

Fault code indication.

The program is stopped, the water intake valve is closed, and the drain pump is switched on for 120 seconds.

#### Cause

The power electronic (ELP) or the control electronic (EW) has registered a technical fault.

The power electronic (ELP) stops the program.

#### Remedy

- ↯ Search the fault memory, refer to Service mode – Overview, 070 4.5, Service Mode Overview, 070 4.6.
- ↯ Refer to the M. No. and check if the correct control electronic (EW) and power electronic (ELP) are installed.
- ↯ Check the electronic connection between the power electronic (ELP) and the control electronic (EW).

### 3.11 F 0 No fault

#### Cause

No fault is saved to the power electronic (ELP).

#### Remedy

- ↯ No action needed.

### 3.12 F 1 NTC short circuit water / heater

#### Symptom

The fault is not indicated in the operating mode.

The heater is switched off within 10 s.

The program is carried out without heating.

**Hot water:** The program is continued with cold water.

#### Cause

Temperature sensor (NTC resistor R30) or connector short circuited.

#### Check the temperature sensor (NTC resistor R30)

- ↯ Check the temperature sensor (NTC resistor R30) in the service mode, refer to Service mode – Overview, 070 4.5, Service Mode Overview, 070 4.6.
- ↯ Check the temperature sensor (NTC) circuit for short circuit, open circuit and isolation.
- ↯ Check the electronic resistance of temperature sensor (NTC resistor R30), refer to 030 Table 2.

### 3.13 F 2 NTC open circuit water / heater

#### Symptom

The fault is not indicated in the operating mode.

The heater is switched off within 10 s.

The program is carried out without heating.

**Hot water:** The program is continued with cold water.

#### Cause

Open circuit in temperature sensor (NTC resistor R30) or line.

#### Check the temperature sensor (NTC resistor R30)

- ↯ Check the temperature sensor (NTC resistor R30) in the service mode, refer to Service mode – Overview, 070 4.5, Service Mode Overview, 070 4.6.
- ↯ Check the temperature sensor (NTC) circuit for short circuit, open circuit and isolation.
- ↯ Check the electronic resistance of temperature sensor (NTC resistor R30), refer to 030 Table 2.

### 3.14 F 10 Water intake fault cold water

#### Symptom

The message in the operating mode: Water intake fault.

The LED "check water intake" flashes rapidly.

The program is stopped, the water intake valve is closed, and the drain pump is switched on for 120 seconds.

Water intake control refer to 040 2.4 Water intake monitoring – water control system (WCS).

#### Cause

Only until the first commissioning: The spin lock is activated.

#### Remedy

- ✍ Run a short wash program up to water intake. As the first water intake is registered, the spin lock is released.

#### Note

Spin lock, refer to 060 2.1 Spin lock.

#### Cause

The appliance has a leak, the water control system (WCS) has stopped the water intake.

#### Remedy

- ✍ Shut off the water faucet.
- ✍ Locate the leak and fix it.

#### Cause

The water faucet is closed.

#### Remedy

- ✍ Open the faucet.

#### Cause

Water intake filters are gunked up.



**Remedy**

- ✎ Clean the filters in the water intake path.

**Cause**

Low water pressure on site.

**Check the water pressure on site.**

- ✎ The minimum water flow pressure is 1 bar (100 kPa). With the faucet fully open, at least 5 liters water have to flow from the faucet within 15 seconds.
- ✎ If the minimum water flow pressure is less than 1 bar, the on site water pressure has to be increased.
- ✎ If the available water pressure cannot be increased, program for a lower water pressure, refer to Programming Overview, 070 4.1, Programming Overview, 070 4.2.

**Cause**

Defective water intake valve (Y14) / water intake hose valve (WPS) cold water (1/Y40).

**Remedy**

- ✎ Check valve Y14 / 1/Y40.

**Cause**

**Hot water:** Defective water intake valve (Y12) / water intake hose valve (WPS) hot water (2Y40).

**Remedy**

- ✎ Check valve Y12 / 2/Y40.

### 3.15 F 11 Water drain

#### Symptom

The message in the operating mode: Water drain fault.

The LED "check water drain" flashes.

The program is stopped and the drain pump is switched on for 120 seconds.

Water drain control, refer to 050 2.1 Water drain monitoring.

#### Cause

Insufficient drainage.

#### Remedy

- ↺ Check the foreign body trap.
- ↺ Drain the drain hose.
- ↺ Check the non return device.
- ↺ Check the air circulation to and from the drain pump.
- ↺ Check the function of the drain pump.

### 3.16 F 15 Water intake fault hot water

#### Symptom

The message in the operating mode: Hot water intake fault.

The LED "check water intake" lights up steadily.

The fault is not indicated in the operating mode.

The program is continued with cold water.

Water intake control, refer to 040 2.4 Water intake monitoring – water control system (WCS).

#### Cause

Hot water faucet is closed.

#### Remedy

- ↺ Open the hot water faucet.

#### Cause

Water intake filters are gunked up.

**Remedy**

- ✎ Clean the filters in the hot water intake path.

**Cause**

Low hot water pressure on site.

**Check the water pressure on site.**

- ✎ The minimum water flow pressure is 1 bar (100 kPa). With the faucet fully open, at least 5 liters water have to flow from the faucet within 15 seconds.
- ✎ If the minimum water flow pressure is less than 1 bar, the on site water pressure has to be increased.
- ✎ If the available water pressure cannot be increased, program for a lower water pressure, refer to Programming Overview, 070 4.1, Programming Overview, 070 4.2.

**Cause**

Defective water intake valve (Y12) / water intake hose valve (WPS) cold water (2Y40).

**Remedy**

- ✎ Check valve Y12 / 2Y40.

**3.17 F 16 Oversudsing****Symptom**

In the operating mode, at the end of the program, the display indicates: Check dosage.

The LED "Check dosage" lights up steadily.

The water intake valve is switched off intermittently.

The heater is switched off, without fault message that the target temperature has not been reached.

The spin speed is reduced, or the spin cycle is stopped.

An additional rinse cycle is carried out.

Foam sensing, refer to 030 2.1 Foam sensing.

**Cause**

Oversudsing due to excess detergent usage.

**Observe the dosage recommendation.**

- ↷ Observe the dosage recommendations of the detergent manufacturer, and keep in mind the water hardness and degree of soiling.

**Cause**

Air circulation hose is clogged, causing an increase in pressure during water intake.

**Remedy**

- ↷ Clean the air circulation hose.

**Cause**

Malfunction in the cycle.

**Remedy**

- ↷ Check the drain and the drain pump.

**3.18 F 19 Flow meter is sluggish (flow meter (B3/4) / current volume meter)****Symptom**

The fault is not indicated in the operating mode.

Or water intake fault.

**Fault detection:** The fault is detected if during water intake an increase in the water level is registered, but the control does not have a signal from the flow through meter (B3/4) / current volume meter.

Flow through meter (B3/4), refer to 040 2.6 Flow meter (B3/4).

Water intake control, refer to 040 2.4 Water intake monitoring – water control system (WCS).

**Cause**

Water intake fault.

**Remedy**

- ↷ Correct the water intake fault. Refer to F 10 Water intake fault cold water, 070 3.14.

**Cause**

No, or too few, impulses from the reed float of the flow through meter (B3/4).

**Remedy**

- ↯ Check the flow through meter (B3/4).
- ↯ Check the wiring harness of the flow through meter (B3/4).

**Cause**

Short circuit or open circuit in the flow through meter (B3/4) / volume counter

**Remedy**

- ↯ Check the flow through meter (B3/4) for short circuit/open circuit.

**Cause**

The program function volume counter is deactivated.

**Remedy****Note**

The program function volume counter is automatically deactivated, if the flow through meter (B3/4) permanently does not send a signal.

- ↯ Set the program function activate volume counter Programming Overview, 070 4.1, Programming Overview, 070 4.2.

### 3.19 F 20 Heater (R1)

**Symptom**

The fault is not indicated in the operating mode.

Poor wash results.

The suds are not heated up.

Long running times.

**Cause**

The target temperature is not reached before the thermo stop time.

The heater (R1) is defective.

**Check the heater**

- ↯ Check the heater element for short circuit, open circuit and isolation.

### 3.20 F 34 Door does not lock

#### Symptom

Program does not start after the "Start" pad is pressed.

A running program is stopped.

The door lock (A2) does **not** lock.

Function door lock (A2), refer to 020 2.1 Pull door lock (A2).

Display: Door lock blocked.

LED "Locked" flashes rapidly.

The fault will be deleted the next time the appliance is successfully unlocked.

#### Cause

Drum overloaded.

#### Remedy

↯ Do not exceed the stated maximum laundry load.

#### Cause

The door lock (A2) is defective.

#### Remedy

↯ Check the door lock (A2) contacts L / L', N / N'.

↯ Check the door lock (A2) wiring harness.

### 3.21 F 35 Door does not release

#### Symptom

In the operating mode the display indicates: Door lock blocked.

The LED "Locked" flashes rapidly.

Function door lock (A2), refer to 020 2.1 Pull door lock (A2).

The fault will be deleted the next time the appliance is successfully unlocked.

#### Cause

Drum overloaded.

#### Remedy

↯ Do not exceed the stated maximum laundry load.

#### Cause

The door lock (A2) is defective.

#### Remedy

↯ Check the door lock (A2) contacts L / L', N / N'.

↯ Check the door lock (A2) wiring harness.

### 3.22 F 39 Electronic fault (BAE)

#### Cause

Control electronic (EW)

#### Remedy

↯ Replace the control electronic (EW).

**3.23 F 41 Electronic fault (faulty EEPROM / faulty data)****Symptom**

The program runs at default values.

In the operating mode the display indicates: Technical fault.

The program is stopped, the water intake valve is closed, and the drain pump is switched on for 120 seconds.

The fault indication will be deleted when the appliance is disconnected from power.

**Cause**

Internal defect of power electronic (ELP).

**Remedy**

- ↯ If no malfunction exists, no action is required.
- ↯ Replace the power electronic (ELP).

**3.24 F 43 Appliance model is not programmed****Symptom**

In the operating mode the display indicates: Technical fault.

It's not possible to start a program.

**Cause**

Control electronic (EW) and power electronic (ELP) are not compatible.

**Remedy**

- ↯ Refer to the M. No. and check if the correct control electronic (EW) and the correct power electronic (ELP) are installed.



### **3.25 F 44 Electronic fault (defective connection I<sup>2</sup>C-Bus)**

#### **Symptom**

In the operating mode the display indicates: Technical fault.

The program is stopped, the water intake valve is closed, and the drain pump is switched on for 120 seconds.

#### **Cause**

Internal technical defect of the power electronic (ELP).

#### **Remedy**

✎ Replace the power electronic (ELP).

### **3.26 F 45 Electronic fault (defective flash RAM/ wrong data)**

#### **Cause**

Internal fault power electronic (ELP).

#### **Remedy**

✎ Refer to the M. No. and check if the correct control electronic (EW) and the correct power electronic (ELP) are installed.

✎ With the program function, reset all to the Delivery status. Then program all necessary settings.

✎ Replace the power electronic (ELP).

**3.27 F 46 Display****Symptom**

This fault cannot be indicated.

This fault can be read via the Miele diagnostic support (DU).

**Cause**

Internal fault of the control electronic (EW).

**Remedy**

↗ Replace the control electronic (EW).

**3.28 F 47 Electronic fault (defective interface EW/ELP)****Symptom**

In the operating mode the display indicates: Technical fault.

The program is stopped, the water intake valve is closed, and the drain pump is switched on for 120 seconds.

**Cause**

Defective interface of EW/ELP.

**Remedy**

↗ Check the wiring harness/connection EW/ELP.

### 3.29 F 50 Drive

#### Symptom

In the operating mode the display indicates: Technical fault.

No drive.

The program is stopped, the water intake valve is closed, and the drain pump is switched on for 120 seconds.

#### Cause

Defective motor, which in turn causes the fault “defective frequency converter”.

#### Remedy

↯ Check the motor, refer to Drum drive defective, 060 3.1.

#### Cause

Defective frequency converter (FU).

#### Remedy

↯ Replace the frequency converter (FU).

### 3.30 F 51 Pressure sensor

#### Symptom

In the operating mode the display indicates: Technical fault.

The LED “Soak” flashes rapidly.

The program is stopped, the water intake valve is closed, and the drain pump is switched on for 120 seconds.

#### Cause

Analog pressure sensor (ADS) can't be detected by electronic unit.

#### Note

The pressure sensor is integrated into the power electronic (ELP).

#### Remedy

↯ Check the pressure sensor, refer to Service mode – Overview, 070 4.5, Service Mode Overview, 070 4.6.

### 3.31 F 53 Speed meter (tachogenerator)

#### Symptom

In the operating mode the display indicates: Technical fault.

The LED "Soak" flashes rapidly.

The drum or the drive are blocked, the drive does not start or is switched off after 1.5 seconds.

This incident is repeated during two reverse tumble cycles.

In the program cycle "spin" there is an immediate stop.

It is possible that after a cooldown phase, the drive works again on and off.

The program is stopped, the water intake valve is closed, and the drain pump is switched on for 120 seconds.

#### Cause

The tachogenerator is defective.

The power electronic (ELP) does not receive any usable alternating signal from the tachogenerator.

#### Check the tachogenerator

↗ Check the tachogenerator, refer to Drum drive defective, 060 3.1.

#### Cause

Defective drive.

The power electronic (ELP), via the tachogenerator, detects a significant difference in the spin speed between the target number and the actual number.

#### Remedy

↗ Check the drive, refer to Drum drive defective, 060 3.1.

### 3.32 F 56 No spin action

#### Symptom

Final spin speed  $< 400 \text{ min}^{-1}$ , when the target spin speed is at least  $450 \text{ min}^{-1}$ .

Fault detection: Tachogenerator

#### Cause

Final spin speed  $< 400 \text{ min}^{-1}$ , when the target spin speed is at least  $450 \text{ min}^{-1}$ .

#### Remedy

- ↯ Check the dosage, refer to F 16 Oversudsing, 070 3.17.
- ↯ Check the drive, refer to Drum drive defective, 060 3.1.

### 3.33 F 63 Water path control fault

#### Symptom

In the operating mode the display indicates: Technical fault.

The LED "water intake" flashes rapidly.

The program is stopped, the water intake valve is closed, and the drain pump is switched on for 120 seconds.

#### Cause

Defective water path system.

The ELP does not detect a valid position, approx. 80 seconds after the water path system is switched on.

#### Note

The water intake can only proceed if a valid water path position is registered.

#### Check the water path system

- ↯ Check the water path system for short circuit, open circuit and isolation.

### 3.34 F 92 Bacterial control

W 4840

#### Symptom

At the end of the program the display indicates: Hygiene Info.

At the end of the program, the LED 140 °F on the temperature list flashes.

#### Cause

If laundry is always run at low temperatures, bacteria can start to grow in the washer. A counter keeps track of the number of programs that are washed at a target temperature of  $\leq 104$  °F (40 °C). After a certain number, the prompt appears to run a program at a target temperature of  $\geq 140$  °F (60 °C). After the wash program at  $\geq 140$  °F, the counter resets to 0.

#### Remedy

- ↻ Run a program at a target temperature of  $\geq 140$  °F. This resets the counter and the message.
- ↻ To deactivate the program function hygiene, refer to 070 2.3.32 Hygiene. The message no longer appears.

### 3.35 Residual time keeps changing

#### Cause

The load automatic detects different load amounts and adjusts the water / energy consumption as well as the program time, and with it the residual time indication.

#### Remedy

- ↻ Load automatic function, refer to 040 2.3 Automatic load control / Intelligent water intake (IWE).

### 3.36 Maximum spin speed is not reached

#### Cause

A wrong option has been set for the program function **maximum spin speed**.

#### Remedy

✎ Set the **maximum spin speed** to match the appliance model.

### 3.37 Water path control (M24) is not activated as programmed

#### Symptom

The water path control is permanently activated in wash programs with the selection "pre-wash".

#### Cause

In the program function **water valves** the option **valves** has been selected.

#### Remedy

✎ In the program function **water valves** set the option to **water path control** according to the appliance model.

### 3.38 Long program running times

#### Cause

In the program function **water plus** the option **additional rinse cycle** has been selected.

#### Remedy

✎ In the program function **water plus** set the option to **water+**.

#### Cause

Child safety sensor

#### Remedy

✎ Child safety sensor, refer to 070 2.1 Child safety sensor.

## 4 Service

### 4.1 Programming Overview

W 4840

#### Initial requirements

- ✍ Install and connect the appliance correctly.
- ✍ End the current program as well as the demo mode.
- ✍ Open the door.

#### Accessing

**Note**

Access has to be completed within 10 s.

- ✍ Press Start and hold.
- ✍ Close the door.
- ✍ Release the Start pad, as soon as the Start LED flashes.
- ✍ Press Start **5 times** and **at the 5th time, hold** until the Start LED flashes rapidly (5 Hz).

#### Acknowledgement indicator

Start LED flashes rapidly (5 Hz).

**Display:** The display shows the service department program mode.

If access is not successful, the control reverts automatically to “select program”.

#### Options

The keypads below the display activate the menu options.

**Note**

Keypad: The function of each pad depends on the menu and is indicated in the display.



- ✎ **To select the program function:** Press the **left keypad below the display (arrow pointing down)** to select the program function and confirm by pressing the **right keypad (OK)** below the display.
- ✎ **To select the option:** Press the **left keypad below the display (arrow pointing down)** to select the option and confirm by pressing the **right keypad (OK)** below the display.

The selected **Option** is marked by a **V**.

- ✎ **To return to the programming menu:** Press the option **Back** and confirm.

### Warning!

For the appliance to function properly, specific options for the country it is operating in have to be selected.

The service department software has to be adapted.

Program function	Option
<b>Reset</b> refer to 070 2.3.23 Reset	Reset all programming options to <b>delivery status</b>
<b>Language selection</b> refer to 070 2.3.6 Language	Select the language. USA: <b>English</b>
<b>Water Plus</b> increase in water level / extra rinse cycle 070 2.3.1 Water Plus	Water +: Increase in water level in soak, pre-wash, main wash and in the rinse cycles by selecting water plus, in the programs Cottons very hot, Minimum iron, Silk, Mini, Automatic/Mixed load
	Extra rinse cycle: Additional rinse cycle by pressing pad water plus, in the programs Cottons very hot, Minimum iron, Silk, Mini, Automatic/Mixed load
	<b>USA:</b> Water + and extra rinse. Increase in water level in soak, pre-wash, main wash and in the rinse cycles by selecting water plus, in the programs Cottons very hot, Minimum iron, Silk, Mini, Automatic/Mixed load, as well as additional rinse cycle in programs Cottons very hot and Minimum iron
Permanent <b>Gentle action</b> refer to 070 2.3.2 Gentle cycle	<b>off: not activated</b>
	on: activated
<b>Suds cooling</b> (reactivation) refer to 070 2.3.3 Suds cooling	<b>off: not activated</b>
	on: activated
<b>Temperature</b> refer to 070 2.3.20 Temperature	°C
	°F
<b>Buzzer</b> refer to 070 2.3.5 Buzzer	Fascia panel without buzzer pad: <b>off</b>
	With buzzer: Volume represented in bars. Delivery status: 3 bars.
<b>Keypad tone</b> refer to 070 2.3.22 Keypad tone	off
	USA: <b>on</b>
Display <b>Contrast</b> refer to 070 2.3.7 Contrast	Set the display contrast: Contrast represented in bars. Delivery status: <b>5 bars</b>
Display <b>Brightness</b> refer to 070 2.3.30 Brightness	Set the display brightness: Brightness represented in bars. Delivery status: <b>5 bars</b>
<b>Standby</b> refer to 070 2.3.8 Standby	On: Display and back light are switched off after 10 minutes
	<b>not during a running program:</b> Active only before and after a program, but not during a running program
<b>Memory</b> (save last special setting) refer to 070 2.3.4 Memory	off: Memory function not active
	<b>on:</b> Memory function active
<b>Drum light</b> refer to 070 2.3.29 Drum light	Appliance without drum light: off
	Appliance with drum light: <b>on</b>

Program function	Option
<b>Water intake</b> refer to 070 2.3.9 Water intake	Cold (cold water / potable water)
	<b>Hot + cold</b>
	Hot water and hot rinse
<b>Maximum water level</b> refer to 070 2.3.10 Max. water level	<b>off: not activated</b>
	on: activated
<b>Flow meter</b> refer to 070 2.3.21 Current volume meter (VSZ)	no: not activated
	<b>yes: activated</b>
<b>Low water pressure</b> refer to 070 2.3.17 Low water pressure	<b>no: not activated</b>
	yes: activated
Sensor controlled <b>Rinse process</b> refer to 070 2.3.19 Sensor controlled rinse cycle	<b>no: not activated</b>
	yes: activated
<b>Allergy</b> refer to 070 2.3.18 Allergy	<b>off: not activated</b>
	on: activated
<b>Country version</b> refer to 070 2.3.11 Country version	EU: Europa
	S: Sweden
	AUS: Australia
	USA: United States of America
<b>Automatic load control</b> refer to 070 2.3.13 Load automatic	off: not activated, for detergent test facilities only
	<b>off: not activated</b>
<b>Heater rating</b> refer to 070 2.3.16 Heater output	<b>1060 W</b>
	2100 W, 4200 W, 2600 W, 3000 W, 720 W, 4600 W, 5300 W, 2500 W, 8100 W
<b>Drum</b> refer to 070 2.3.15 Central unit	<b>ASA 8 kg synthetic fiber suds container</b>
<b>Imbalance charts</b> refer to 070 2.3.14 Imbalance values	<b>Imbalance chart 1</b>
	Imbalance chart 2
<b>Maximum spin speed</b> refer to 070 2.3.12 Max. spin speed	<b>1400 RPM</b>
	2000 RPM, 1900 RPM, 1800 RPM, 1700 RPM, 1600 RPM, 1500 RPM, 1300 RPM, 1200 RPM,
<b>Water valve</b> refer to 070 2.3.25 Water valves	<b>USA: Water control path with 5 positions</b>
	Valves
	Water control path with 4 positions
<b>Machine</b> refer to 070 2.3.27 Appliance	<b>Front loader</b>
	Top loader
<b>Imbalance sensor</b> refer to 070 2.3.24 Imbalance sensor	Speed sensor (Tachogenerator)
	<b>Tacho &amp; Imbalance sensor</b>
	Tacho & Load sensor

Program function	Option
<b>Hygiene</b> refer to 070 2.3.32 Hygiene	off
	on
<b>Chlorine bleach</b> refer to 070 2.3.34 Chlorine / Bleach agent intake	off
	on
<b>Exit</b>	End programming mode

**Table 2:** Programming mode overview

## Save and quit

### Note

The indicated programming options are saved in the power electronic (ELP).

- ✎ Select program function **Exit** and confirm.

## 4.2 Programming Overview

W 4800

### Initial requirements

- ✎ Install and connect the appliance correctly.
- ✎ End the current program as well as the demo mode.
- ✎ Open the door.

### Accessing

### Note

Access has to be completed within 10 seconds.

- ✎ Press Start and hold.
- ✎ Close the door.
- ✎ Release the Start pad, as soon as the Start LED flashes.
- ✎ Press Start **5 times** and **at the 5th time, hold** until the Start LED flashes rapidly (5 Hz).

### Acknowledgement indicator

Start LED flashes rapidly (5 Hz).

If access is not successful, the control reverts automatically to “select program”.

### Options

☞ **To select a program function:** Press **Buzzer pad**.

The program function is indicated by the flashing of the buzzer LED.

☞ **To select an option:** Press **Start**.

The selected **Option** is indicated by the flashing of the prewash LED.

#### Warning!

For the appliance to function properly, specific options for the country it is operating in have to be selected.

The service department software has to be adapted.

Program function			Prewash LED		
Buzzer LED	long	short	Option	long	short
Reset refer to 070 2.3.23 Reset	-	1	adapted options	-	0
			<b>Delivery status</b>	-	1
<b>Water Plus</b> Increase in water level / extra rinse cycle 070 2.3.1 Water Plus	-	2	Water +: Increase in water level in soak, pre-wash, main wash and in the rinse cycles by selecting water plus, in the programs Cottons very hot, Minimum iron, Silk, Mini, Automatic/Mixed load	-	1
			Extra rinse cycle: additional rinse cycle by pressing pad water plus, in the programs Cottons very hot, Minimum iron, Silk, Mini, Automatic/Mixed load	-	2
			<b>USA:</b> Water + and extra rinse. Increase in water level in soak, pre-wash, main wash and in the rinse cycles by selecting water plus, in the programs Cottons very hot, Minimum iron, Silk, Mini, Automatic/Mixed load as well as additional rinse cycle in programs Cottons very hot and Minimum iron	-	3
Permanent <b>Gentle action</b> refer to 070 2.3.2 Gentle cycle	-	3	<b>off: not activated</b>	-	0
			on: activated	-	1
<b>Suds cooling</b> (Reactivate) refer to 070 2.3.3 Suds cooling	-	4	<b>off: not activated</b>	-	0
			on: activated	-	1
<b>Soak</b>	-	5	<b>120 min</b>	-	1
			90 min	-	2
			60 min	-	3
			30 min	-	4
			15 min	-	5
<b>Buzzer</b> refer to 070 2.3.5 Buzzer	-	6	Fascia panel without buzzer pad: off	-	0
			With buzzer pad: Volume represented in bars. Delivery status: 3 bars.	-	1

Program function			Prewash LED		
Buzzer LED	long	short	Option	long	short
<b>Keypad tone</b> refer to 070 2.3.22 Keypad tone	-	7	off	-	0
			<b>USA: On</b>	-	1
<b>Save last special setting (memory)</b> refer to 070 2.3.4 Memory Check: Off	-	8	Off: Memory function not activated.	-	0
			<b>USA: On: Memory function activated.</b>	-	1
<b>Water intake</b> refer 070 2.3.9 Water intake	-	9	Cold (cold water / potable water)	-	1
			<b>USA: hot + cold</b>	-	2
			Hot water and hot rinse	-	3
<b>Maximum water level</b> refer to 070 2.3.10 Max. water level	1	-	<b>USA: off: not activated</b>	-	0
			on: activated	-	1
<b>Country version</b> refer to 070 2.3.11 Country version	1	1	EU: Europa	-	1
			S: Sweden	-	2
			AUS: Australien	-	3
			<b>USA: United States of America</b>	-	4
<b>Automatic load control</b> refer to 070 2.3.13 Load automatic	1	2	off: not activated, for detergent test facilities only	-	0
			<b>on: activated</b>	-	1
<b>Imbalance chart</b> refer to 070 2.3.14 Imbalance values	1	3	<b>Imbalance chart 1</b>	-	0
			Option not available at this time	-	1
<b>Drum</b> refer to 070 2.3.15 Central unit	1	4	<b>8 kg synthetic fiber suds container</b>	-	0
			not available	-	1
<b>Heater rating</b> refer to 070 2.3.16 Heater output	1	5	<b>USA: 2100 W</b>	-	1
			4200 W	-	2
			2600 W	-	3
<b>Low water pressure</b> refer to 070 2.3.17 Low water pressure	1	6	<b>no: not activated</b>	-	0
			yes: activated	-	1
<b>Allergy</b> refer to 070 2.3.18 Allergy	1	7	<b>off: not activated</b>	-	0
			on: activated	-	1
Sensor controlled <b>Rinse process</b> refer to 070 2.3.19 Sensor controlled rinse cycle	1	8	<b>USA: no: not activated</b>	-	0
			yes: activated	-	1
<b>Flow meter</b> refer to 070 2.3.21 Current volume meter (VSZ)	1	9	no: not activated	-	0
			<b>USA: yes: activated</b>	-	1
<b>Maximum speed</b> refer to 070 2.3.12 Max. spin speed	2	-	<b>1300 RPMn</b>	2	-
<b>Imbalance sensor</b> refer to 070 2.3.24 Imbalance sensor	2	1	Speed sensor (Tachogenerator)	-	1
			<b>Imbalance sensor and spin speed sensor (Tachogenerator)</b>	-	2
			Spin speed sensor (Tachogenerator)	-	3
<b>Water valves</b> refer to 070 2.3.25 Water valves	2	2	<b>USA: Water path control with 5 positions</b>	-	1
			Valves	-	2
			Water path control with 4 positions	-	3

Program function			Prewash LED		
Buzzer LED	long	short	Option	long	short
Indication 070 2.3.26 Display	2	3	without 7-segment indication	-	0
			with 7-segment indication	-	1
Residual time	2	4	without residual time indication	-	0
			with residual time indication	-	1
Delay start	2	5	without start preselection	-	0
			with start preselection	-	1
Appliance refer to 070 2.3.27 Appliance	2	6	Frontloader	-	0
			Toploader	-	1
Load indication refer to 070 2.3.28 Load indication	2	7	no indication	-	1
			load	-	2
			dosage	-	3
			load + dosage	-	4
Drum light refer to 070 2.3.29 Drum light	2	8	unit without drum light: Off	-	0
			USA: unit with drum light: On	-	1
Fascia panel type -change over, refer to 070 2.3.31 Fascia panel type	2	9	5 kg Front /Toploader, extras "Intensive"	-	1
			6 kg Frontloader, extras "Short"	-	2
			USA: 6 kg Frontloader, extras "Short", as well as extras as options in special programs	-	3
Prewash for heavy soil, refer to 070 2.3.33 Prewash at heavy soil	3	0	Without prewash when selecting heavy soil	-	0
			With prewash when selecting heavy soil	-	1
Hygiene refer to 070 2.3.32 Hygiene	2		off	-	0
			on	-	1
Chlorine bleach refer to 070 2.3.34 Chlorine / Bleach agent intake			off	-	0
			on	-	1

Table 3: Programming mode overview

## Save and quit

### Note

The indicated programming options are saved in the power electronic (ELP).

 Open the door.

## 4.3 Demo mode – activate / deactivate

W 4840

### Initial requirements

- ✎ Finish the current program.
- ✎ Open the door.

### Accessing

#### Note

Access has to be completed within 10 seconds.

- ✎ **Press and hold** Start.
- ✎ Close the door.
- ✎ When the Start LED **lights up steadily**, after approx. 5 s, release the Start pad.
- ✎ **Press Start again quickly and hold**, until after approx. 4 s, the Start LED dims.

### Acknowledgement indicator

The Start LED flashes slowly (1 Hz).

If access is not successful, the control automatically reverts to “select program”.

### Options

**Display:** Follow the prompt in the display.

The demo program runs through automatically.

One demo program cycle lasts approx. 40 seconds.

#### Note

After a power interruption, the demo program starts again on its own.

- ✎ **Program simulation / Interactive demo mode:** In the demo mode, the appliance can be operated, without a program being started.

### Save and quit

- ✎ To deactivate the demo program, repeat the access procedure.

## 4.4 Demo mode – activate / deactivate

W 4800

### Initial requirements

- ✎ Finish the current program.
- ✎ Open the door.

### Accessing

#### Note

Access has to be completed within 10 seconds.

- ✎ **Press and hold** Start.
- ✎ Close the door.
- ✎ When the Start LED **lights up steadily**, after approx. 5 s, release the Start pad.
- ✎ **Press Start again quickly and hold**, until after approx. 4 s, the Start LED dims.

### Acknowledgement indicator

The Start LED flashes in a rhythm of 2x short, 1 s pause.

If access is not successful, the control reverts automatically to the normal programming mode.

### Options

The demo program runs through automatically.

One demo program cycle lasts approx. 40 seconds.

#### Note

After a power interruption, the demo program starts again on its own.

- ✎ **Operating simulation / Interactive demo mode:** In the demo mode, the appliance can be operated, without a program being started.

### Save and quit

- ✎ To deactivate the demo program, repeat the access procedure.



## 4.5 Service mode – Overview

W 4840

### Initial requirements

- ✎ Install and connect the appliance correctly.
- ✎ End the current program as well as the demo mode.
- ✎ Open the door.

### Accessing

#### Note

Access has to be completed within 10 seconds.

- ✎ Press Start and hold.
- ✎ Close the door.
- ✎ When the Start LED flashes, release the Start pad.
- ✎ Press Start **3 times** and **at the 3rd time, hold** until the Start LED flashes slowly (1 Hz).

### Acknowledgement indicator

The Start LED flashes slowly (1 Hz).

The display shows the customer service mode.

If access is not successful, the control reverts automatically to the normal programming mode.

### Options

#### Note

The keypads below the display activate the menu options.

The function of each keypad depends on the menu and is indicated in the display.

- ✎ **To select a service function:** Press the left pad below the display.
- ✎ **To start a service function:** Press the right pad (OK) below the display.
- ✎ **To continue in service functions:** Press the left pad below the display.

**Note**

The component test switches off automatically 30 minutes after the last component is activated.

Service function	Component / Sensor		
<b>Program index / Softwarestatus</b>	With display: Software status, ID of power electronic (ELP), ID of control electronic		
	Without display: Program index, ID of power electronic (ELP), ID of control electronic		
Check <b>Fault Memory</b> <sup>1)</sup> and delete <sup>2)</sup>	<b>Fault memory</b>	<b>Fault code</b>	<b>Remedy</b>
	No fault	F 0	refer to F 0 No fault, 070 3.11
	NTC short circuit water / heater	F 1	refer to F 1 NTC short circuit water / heater, 070 3.12
	NTC open circuit water / heater	F 2	refer to F 2 NTC open circuit water / heater, 070 3.13
	Water intake fault cold water	F 10	refer to F 10 Water intake fault cold water, 070 3.14
	Water drain	F 11	refer to F 11 Water drain, 070 3.15
	Water intake fault hot water	F 15	refer to F 15 Water intake fault hot water, 070 3.16
	Oversudsing	F 16	refer to F 16 Oversudsing, 070 3.17
	Flow meter sluggish	F 19	refer to F 19 Flow meter is sluggish (flow meter (B3/4) / current volume meter), 070 3.18
	Heater (Temperature in thermostop not reached)	F 20	refer to F 20 Heater (R1), 070 3.19
	Door does not lock	F 34	refer to F 34 Door does not lock, 070 3.20
	Door lock does not release	F 35	refer to F 35 Door does not release, 070 3.21
	Faulty EEPROM / Data faulty	F 41	refer to F 41 Electronic fault (faulty EEPROM / faulty data), 070 3.23
	Appliance not programmed	F 43	refer to F 43 Appliance model is not programmed, 070 3.24
	Connection I <sup>2</sup> C-Bus faulty	F 44	refer to F 44 Electronic fault (defective connection I <sup>2</sup> C-Bus), 070 3.25
	Flash	F 45	refer to F 45 Electronic fault (defective flash RAM/ wrong data), 070 3.26
	Display	F 46	refer to F 46 Display, 070 3.27
	Interface EW / ELP	F 47	refer to F 47 Electronic fault (defective interface EW/ELP), 070 3.28
	Drive	F 50	refer to F 50 Drive, 070 3.29
	Pressure sensor	F 51	refer to F 51 Pressure sensor, 070 3.30
	Speed meter (tachogenerator)	F 53	refer to F 53 Speed meter (tachogenerator), 070 3.31
	No spin	F 56	refer to F 56 No spin action, 070 3.32
	Water path control	F 63	refer to F 63 Water path control fault, 070 3.33
	Bacterial control	F 92	F 92 Bacterial control, 070 3.34
Delete fault memory		OK	

Service function	Component / Sensor	
<b>Component test</b>	<b>Components</b>	<b>Function check</b>
	Water path control (M 24) position 1, only if present, and water intake valve (Y1 or Y14 / Y40 with water path control)	Water run over the porthole for 10 seconds
	Water path control (M 24) position 2, water intake valve (Y1 or Y14 / Y40 with water path control), Heater, Analog pressure sensor	Water run via compartment I to level I. Heating, starting at level I, to 95°F (35°C)
	Water path control (M 24) position 3, water intake valve (Y2 or Y14 / Y40 with water path control), Analog pressure sensor	Water run via compartment II to level II
	Water path control (M 24) position 4, water intake valve (Y1 and Y3, or Y14 / Y40 with water path control), Analog pressure sensor	Water run via compartment III to level III (fabric softener compartment)
	Drain pump (M8)	Activate drain pump, drainage independent of level
	Motor drum drive (M5)	Activate drum, rotation, wash
	Motor drum drive (M5). Drain pump (M8)	Drum drive, spin speed limited according to program selection. Drain pump on / Drain valve open.
	Drum light (H3/6) (optional)	Drum light on
	Hot water valve (Y12 / 2Y40) (optional)	Water run via compartment II to level III
<b>Sensor test</b> 070 2.4.2 Sensor test	<b>Sensors</b>	<b>Status</b>
	Float switch (B8) in the sump	No water in the sump => Float switch not activated => Switch closed => Buzzer on
		Float switch activated => Switch open => Buzzer off
Door contact (A2)	Door closed => Switch closed	
	Door open => Switch open	
<b>Operating hours</b>	Power electronic (ELP), refer to 070 2.4.3 Operating hours meter	Indication of operating hours
<b>Operating</b> 070 2.4.4 Operating	Keypads	Tone to acknowledge when pad is pressed, and the LED corresponding to the pad lights up.
	Buzzer	Acoustic signal
	Display / LED Test	All display items are alternately switched on and off (flashing). All LEDs, except the PC LED, are switched on and off (flashing rhythm).
	Display Backlight	The backlight is switched on and off (flashing rhythm).
	System component test control electronic (EW)	Test result, refer to display
	Control dial version: Test the control dial (DWS)	Program positions are indicated

**Table 4:** Service Mode Overview

<sup>1)</sup> **Several faults** are shown by pressing the **left keypad below the display**.

<sup>2)</sup> **Delete fault memory:** Select option "Delete fault memory" and press the **right pad (OK) below the display**.

### Quit (without saving)

#### Note

Delete the fault memory before ending.

✎ Select service function **Exit** and confirm.

## 4.6 Service Mode Overview

W 4800

### Initial requirements

- ✎ Install and connect the appliance correctly.
- ✎ End the current program as well as the demo mode.
- ✎ Open the door.

### Accessing

#### Note

Access has to be completed within 10 seconds.

- ✎ Press Start and hold.
- ✎ Close the door.
- ✎ As soon as the Start LED flashes, release Start.
- ✎ Press Start **3 times** and **at the 3rd time, hold** until the Start LED flashes slowly (1 Hz).

### Acknowledgement indicator

Start LED flashes slowly (1 Hz).

If access is not successful, the control reverts automatically to the normal programming mode.

### Options

- ✎ **To select a service function:** Press the **Buzzer pad**.
- ✎ **To start a service function:** Press **Start**.
- ✎ Actual: after access the buzzer LED flashes 2x. Possible to exit service mode after pressing Start.
- ✎ Actual: Press buzzer, flashing rhythm remains at 2x, now fault code is issued.
- ✎ Actual: Buzzer LED flashes 3x: Component test. However, 9=buzzer on, 10=LED test.

#### Note

The component test switches off automatically 30 minutes after the last component is activated.

Service function		Option		
Buzzer LED	short	Prewash LED	long	short
Software status	-	Program index: ID of the power electronic (ELP), ID of the control electronic (EW)	X	Y
Check <b>Fault memory</b> <sup>1)</sup> and delete <sup>2)</sup>	1	F 0, no fault, refer to F 0 No fault, 070 3.11	-	-
		F 1, NTC short circuit water / heater, refer to F 1 NTC short circuit water / heater, 070 3.12	-	1
		F 2, NTC open circuit water / heater, refer to F 2 NTC open circuit water / heater, 070 3.13	-	2
		F 10, Water intake fault (cold), refer to F 10 Water intake fault cold water, 070 3.14	1	0
		F 11, Water drain, refer to F 11 Water drain, 070 3.15	1	1
		F 15, Water intake fault (hot), refer to F 15 Water intake fault hot water, 070 3.16	1	5
		F 16, Oversudsing, refer to F 16 Oversudsing, 070 3.17	1	6
		F 19, Flow meter sluggish, refer to F 19 Flow meter is sluggish (flow meter (B3/4) / current volume meter), 070 3.18	1	9
		F 20, Heater (Temperature in thermostop not reached), refer to F 20 Heater (R1), 070 3.19	2	-
		F 34, Door does not lock, refer to F 34 Door does not lock, 070 3.20	3	4
		F 35, Door lock does not release, refer to F 35 Door does not release, 070 3.21	3	5
		F 41, Faulty EEPROM / Data faulty, refer to F 41 Electronic fault (faulty EEPROM / faulty data), 070 3.23	4	1
		F 43, Appliance not programmed, refer to F 43 Appliance model is not programmed, 070 3.24	4	3
		F 44, Connection I <sup>2</sup> C-Bus faulty, refer to F 44 Electronic fault (defective connection I <sup>2</sup> C-Bus), 070 3.25	4	4
		F 45, Flash, refer to F 45 Electronic fault (defective flash RAM/ wrong data), 070 3.26	4	5
		F 46, Display, refer to F 46 Display, 070 3.27	4	6
		F 47, Interface EW / ELP, refer to F 47 Electronic fault (defective interface EW/ELP), 070 3.28	4	7
		F 50, Drive, refer to F 50 Drive, 070 3.29	5	-
F 51, Pressure sensor, refer to F 51 Pressure sensor, 070 3.30	5	1		
F 53, Speed meter (tachogenerator), refer to F 53 Speed meter (tachogenerator), 070 3.31	5	3		
F 56, No spin, refer to F 56 No spin action, 070 3.32	5	6		
F 63, Water path control, refer to F 63 Water path control fault, 070 3.33	6	3		
F 92, Bacterial control, refer to F 92 Bacterial control, 070 3.34	9	2		

Service function		Option			
Buzzer LED	short	Prewash LED		long	short
Component test <sup>3)</sup>	2	all components inactive		-	-
		Water path control (M 24) position 1, only if present and water intake valve (Y1 or Y14 / Y40 with water path control)	Water run over the porthole for 10 seconds	-	1
		Water path control (M 24) position 2, water intake valve (Y1 or Y14 / Y40 with water path control), Heater, Analog pressure sensor	Water run via compartment I up to level I. Heating, starting at level I, to 95 °F (35 °C)	-	2
		Water path control M 24 position 3, water intake valve (Y2 or Y14 / Y40 with water path control), Analog pressure sensor	Water run via compartment II up to level II	-	3
		Water path control (M 24) position 4, water intake valve (Y1 and Y3, or Y14 / Y40 with water path control), Analog pressure sensor	Water run via compartment III up to level III (fabric softener compartment)	-	4
		Drain pump (M8)	Activate drain pump, drainage independent of level	-	5
		Motor drum drive (M5)	Activate drum, rotation, wash	-	6
		Motor drum drive (M5) Drain pump (M8)	Drum drive, spin speed limited according to program selection. Drain pump on / Drain valve open.	-	7
		Drum light (H3/6) (optional)	Drum light on	-	8
		Hot water valve (Y12 / 2Y40) (optional)	Water run via compartment II up to level III.	-	9
Sensor test <sup>4)</sup> 070 2.4.2 Sensor test	3	all sensors inactive		-	-
		Float switch (B8) in the sump	No water in the sump => float not activated => switch closed => <b>Buzzer on</b>	-	1
			Float activated => switch open => <b>Buzzer off</b>	-	2
		Door contact (A2)	Door closed => Switch closed => <b>Buzzer on</b>	-	1
Door open => Switch open => <b>Buzzer off</b>	-		2		
Operating hours 070 2.4.3 Operating hours meter	4	Power electronic (ELP). Operating hours	Long flashing signal for the number of 1000s, short flashing signal for the number of 100s. (12 times long + 6 times short = 12000 h + 600 h = 12600 h.	x000 h	y00 h
Operating 070 2.4.4 Operating	5	Keypads	Tone to acknowledge when pad is pressed, and the LED corresponding to the pad lights up.	-	-
		Buzzer	Tone signal	-	-

**Table 5:** Service Mode Overview

<sup>1)</sup> **Indicate fault checks in ascending order:** Press Start.

<sup>2)</sup> **To delete the fault memory:** Press Start pad longer than **4 seconds** (all saved faults are deleted).

<sup>3)</sup> **To select and activate components:** Press Start, after 1 second, activation follows automatically. Pressing Start again switches the current component off and starts the next one. If component testing is stopped and subsequently called up again, the program resumes with the last component that was activated. The component test switches off automatically 30 minutes after the last component is activated.

<sup>4)</sup> **To select a sensor and start the check:** Press Start.

**Quit (without saving)****Note**

Delete the fault memory before ending.

- ✂ Interrupt the power supply.
- ✂ Open the door.

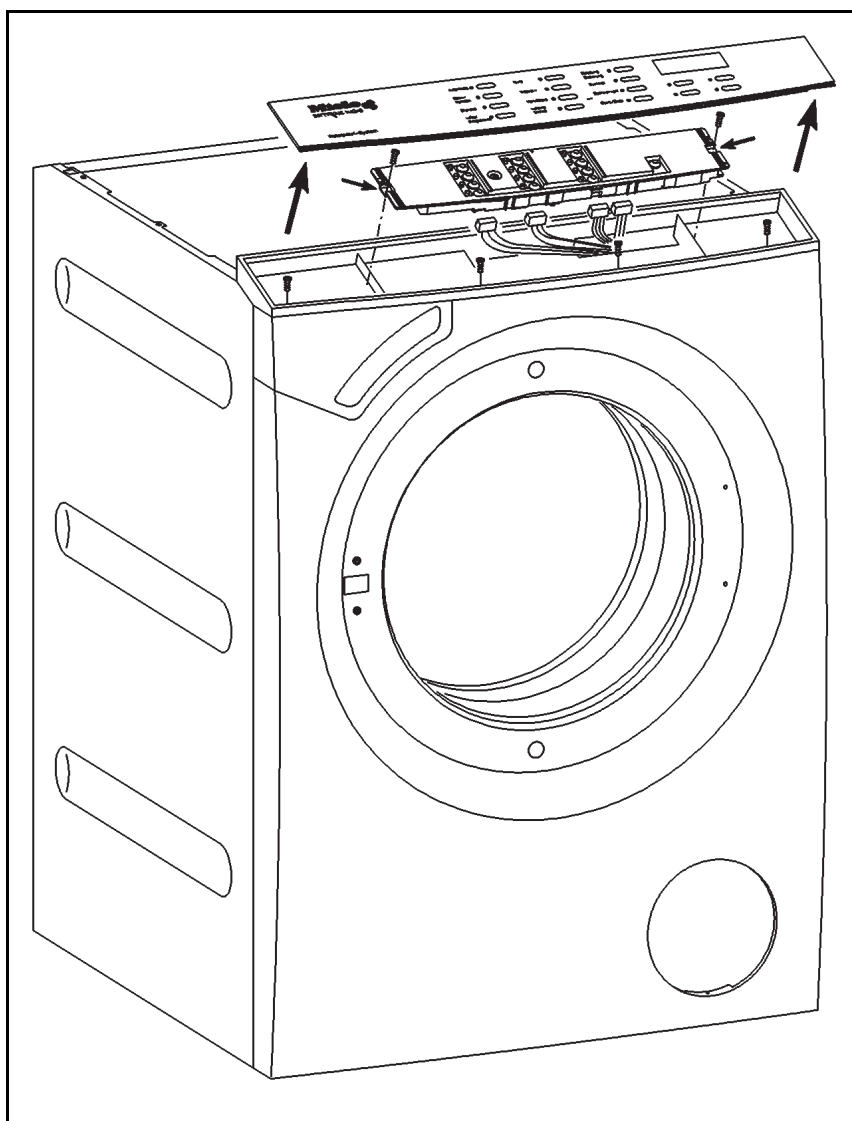
**4.7 Control electronic (EW) and Fascia support panel – Remove****Fig. 1**

- ✂ Remove the fascia panel.
- ✂ Remove the retaining screws of the control electronic (EW), press in on the snap rod and remove the electronic.

- ✎ Remove the lid of the appliance, refer to Lid – Remove, 010 4.1.
- ✎ Take out the detergent compartment drawer.
- ✎ Remove the retaining screws of the fascia support panel.
- ✎ Lift the fascia support panel and remove.



## 090 Electrical System

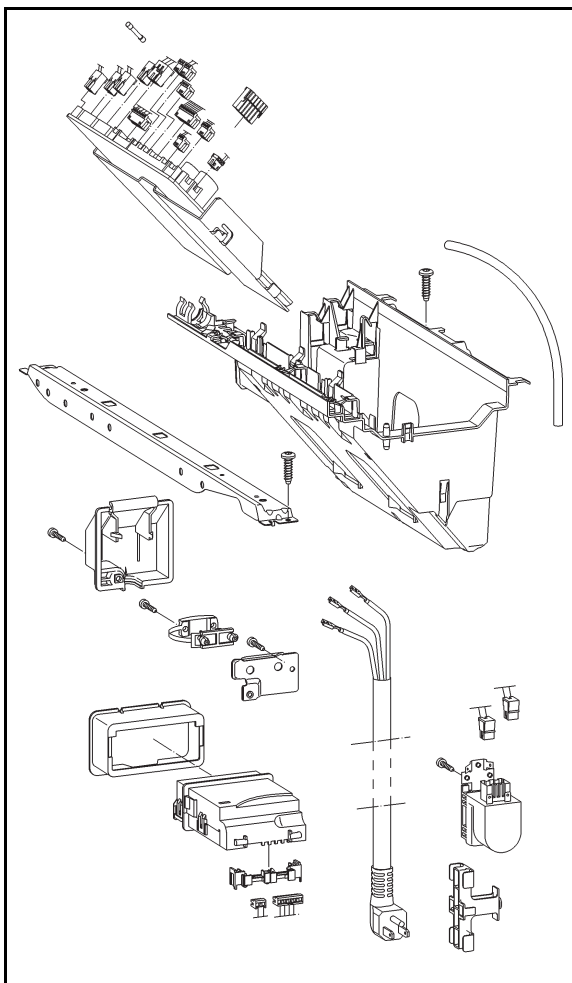

## 1 Technical Data

Electrical System	Main cable 1.5 m
Fine-wire fuse (F7) on power electronic (ELP)	5 mm * 200 mm, 6.3 A slow-blow (F2) Fuses

**Table 1:** Technical data – Electrical System

## 4 Service

### 4.1 Work on the electronic of the frequency converter (ELP)

**Danger!**

Voltage present when working on the frequency converter drive (ELP).

A capacitor on the frequency converter maintains voltage of up to approx. 400 V, even after the appliance is disconnected from power.

After the appliance is disconnected from power, an electrical resistor discharges the capacitor within approx. 2 minutes.

Before starting work on the electronic of the frequency converter drive (ELP), make sure that the capacitor has been safely discharged.

