

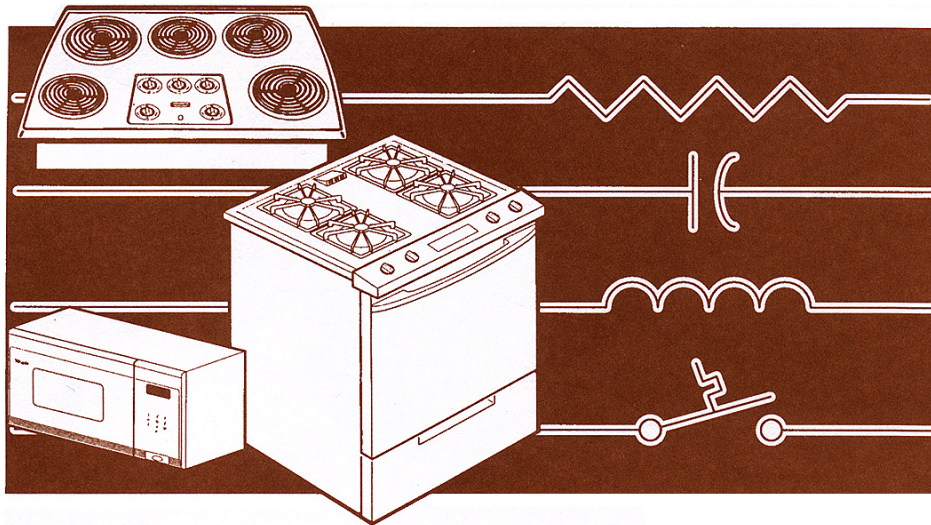

CONSUMER SERVICES TECHNICAL
EDUCATION GROUP PRESENTS

G-20

ELECTRICAL THEORY AND DIAGNOSIS OF MAJOR APPLIANCES



JOB AID
Part No. 4322536A

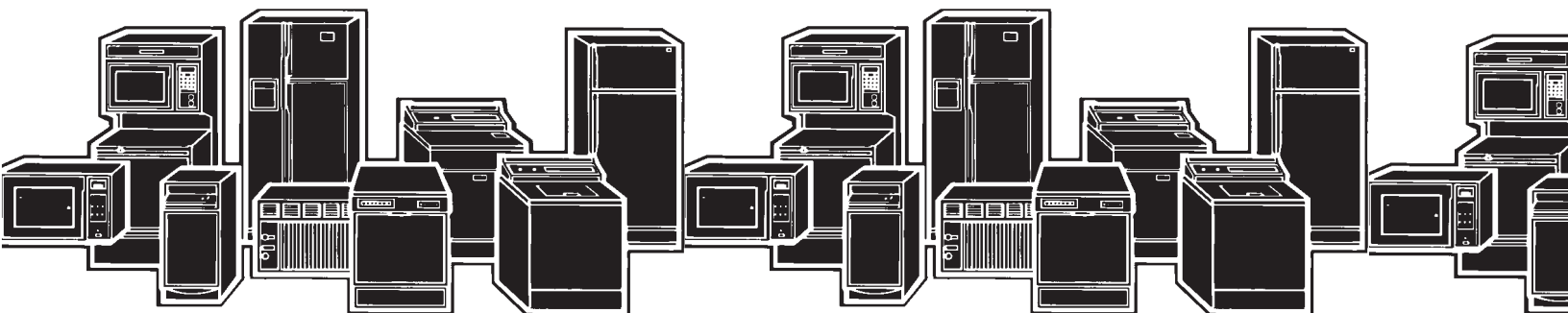

TABLE OF CONTENTS

	Page
SECTION 1	
Basic Electricity	1-1
Introduction	1-1
Electrical Terms	1-2
Ohm's Law	1-4
Circuit Conditions	1-10
Types Of Circuits	1-12
Opens And Shorts	1-17
SECTION 2	
Wiring Diagrams	2-1
Introduction	2-1
Wiring Diagram Terms	2-2
Wiring Diagram Colors	2-3
Wiring Diagram Symbols	2-4
Tracing Circuits	2-12
Using Strip Circuits	2-25
Closing Switches	2-29
Electric Range Wiring Diagram	2-36
Gas Range Wiring Diagram	2-37
Electric Built-In Range Wiring Diagram	2-38
Electric Built-In Range Relay Logic Chart	2-39
Microwave Oven Wiring Diagram	2-40
Self-Cleaning Gas Range Wiring Diagram	2-41
Duet Dryer Wiring Diagram	2-42
Duet Washer Wiring Diagram	2-43
Calypso Washer Wiring Diagram	2-44
Dishwasher Wiring Diagram	2-45

SECTION 1

BASIC ELECTRICITY

INTRODUCTION

Knowing the various types of electrical systems used in modern household appliances will assist you with evaluating the appliance complaints caused by electrical system failures. This is an important key to the fundamental diagnostic process. As you work through this section, you will find that each topic is set up to provide you with:

- A definition of the system or component.
- An explanation of its operation.
- An example of how its function may be applied to an appliance overall operation.

The beginning of this section explains some of the basic electrical fundamentals. Exercises will be used to help in the learning process.

To prepare you for the basis of the content and exercises in this section, we will review some of these electrical fundamentals.

ELECTRICAL TERMS

The following is a list of electrical terms and definitions used throughout this section:

Voltage: Usually referred to as “Electromotive Force” (EMF). This force causes electrons to move from negative to positive.

Current (Amperage): A unit of measurement referring to the intensity, or amount of electrical force through a circuit.

Direct Current (DC): Current that flows only in one direction. DC current is used in the following applications:

- a) Mostly in low-voltage conditions.
- b) Circuits that are conducted over relatively short distances.
- c) Appliances with electronic controls.

Alternating Current (AC): Current that flows in both directions. AC current is used in the following applications:

- a) Low- and high-voltage conditions.
- b) Circuits that are conducted over long distances.
- c) Used to operate the main components in an appliance.

Resistance: The restriction to the flow of electricity in a circuit. Resistance is measured in ohms (Ω).

Infinite Resistance is so much resistance that current cannot flow through the circuit (“open” circuit).

Zero Resistance is no resistance and current can flow through the circuit (“closed” circuit).

Wattage:	The unit of measurement for power, or the work being done by electricity.
Load:	Component that converts electricity to heat, light, or motion. All loads restrict the flow of electricity while performing their work.
Conductor:	Material through which electricity can flow. It will usually be a copper wire, and sometimes the chassis, or metal frame, on which the components are mounted.
Short:	A circuit that offers no resistance to the current flowing through it. A direct short will cause a fuse to blow, or possibly start an electrical fire.
Shorted Switch:	A switch that offers no resistance to the flow of current through it. The switch may have a shorted contact.
Open Switch:	A switch that will not allow current to flow through it. The switch may have an open contact.
Shunt:	A bypass around a load that still offers resistance in the circuit for the flow of current.
Circuit:	A complete path through which electricity can travel.

OHM'S LAW

There is a fundamental relationship between voltage, amperage, and resistance in a closed functional circuit. This relationship is known as "Ohm's Law." Ohm's law states that:

- a) Current is directly proportional to the applied voltage.
- b) Current is inversely proportional to the circuit resistance.

What this really means is:

- a) When the circuit voltage increases, the current increases.
- b) When the circuit voltage decreases, the current decreases.
- c) When the circuit resistance increases, the current decreases.
- d) When the circuit resistance decreases, the current increases.

This relationship can be expressed in the mathematical formulas shown in the illustration below. If two of the three values are known for a circuit, the third value can be found by using one of these formulas.

Wattage also has a direct relationship with the voltage, amperage, and resistance in the circuit. The formula wheel shows all the mathematical relationships these values have with each other.

V = Voltage
 R = Resistance
 A = Amperage
 W = Wattage

$V = A \times R$
 $R = V \div A$
 $A = V \div R$
 $W = V \times A$

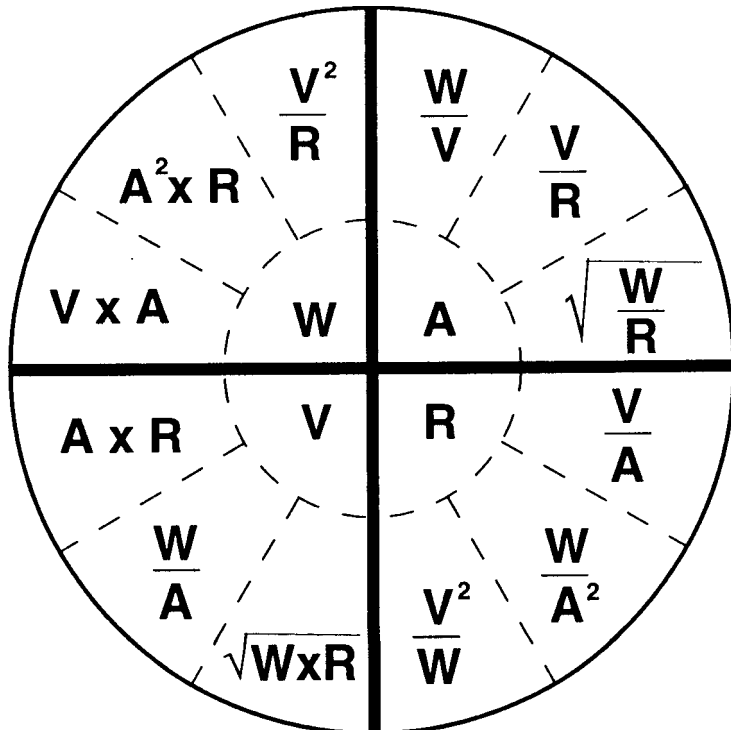

PRACTICE EXERCISE 3

OHM'S LAW

1. If an electric range has four burners rated at 900-, 1500-, 1500-, and 2600-watts, a broil element rated at 2600-watts, and a bake element rated at 2400-watts, what is the amperage draw if the voltage is 240 volts?

Ohm's Law Formula: _____

Answer: _____ amps

2. Voltage applied to a circuit is 120 volts and the current flow is 20 amps. What is the resistance of the circuit?

Ohm's Law Formula: _____

Answer: _____

PRACTICE EXERCISE 3 ANSWERS

OHM'S LAW

1. If an electric range has four burners rated at 900-, 1500-, 1500-, and 2600-watts, a broil element rated at 2600-watts, and a bake element rated at 2400-watts, what is the amperage draw if the voltage is 240 volts?

Ohm's Law Formula: $A = \frac{W}{V}$

Answer: 47.9 amps

2. Voltage applied to a circuit is 120 volts and the current flow is 20 amps. What is the resistance of the circuit?

Ohm's Law Formula: $R = \frac{V}{A}$

Answer: 6 Ω

***IF GIVEN ANSWERS AND YOURS ARE DIFFERENT,
PLEASE REVIEW THE APPROPRIATE SECTION.***



Ohm's Law is a formulation of the relationship of voltage, current, and resistance. The relationships are expressed in the formulas on page 1-8.

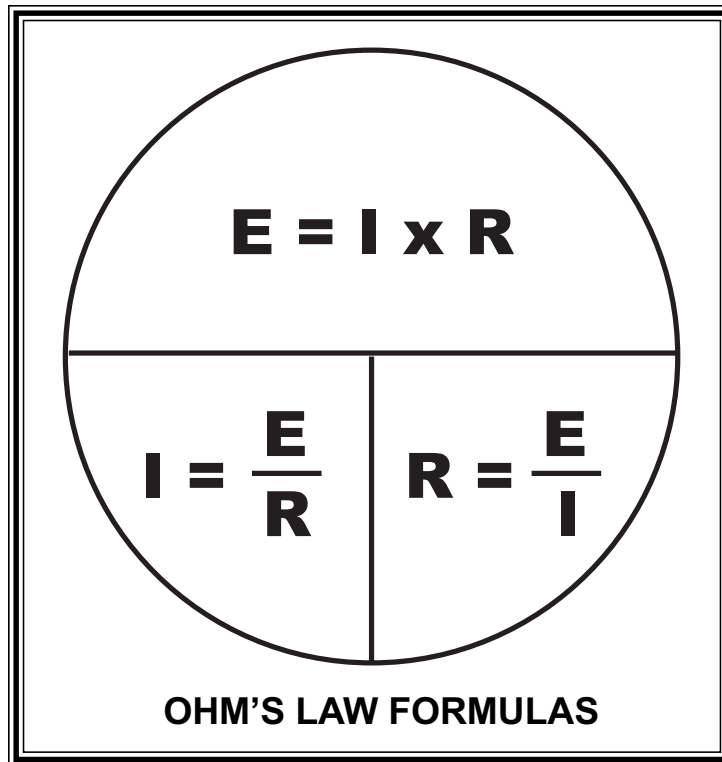

E = Voltage measured in “volts,” and is found by multiplying the current (I) times the resistance (R).

I = Current measured in “amperes,” and is found by dividing the voltage (E) by the resistance (R).

R = Resistance measured in “ohms,” and is found by dividing the voltage (E) by the current (I).

The three formulas used in Ohm's Law can each be used to calculate a missing value in a circuit.

1. In the circuit shown below, there is a current of 12 amperes (12A) and a resistive load of 1 ohm (1Ω). Using the first formula of Ohm's Law, (shown on page 1-8), we can determine the voltage:

$$E = I \times R$$

$$E = 12 \times 1$$

$$E = 12 \text{ volts (12V).}$$

2. We know that a battery is supplying 12 volts of pressure (voltage), and that there is a resistive load of 1 ohm placed in series with it. Using the second formula of Ohm's Law, we can determine the current:

$$I = E \div R$$

$$I = 12 \div 1$$

$$I = 12 \text{ amperes (12A).}$$

3. We know that a battery is supplying 12 volts, and that there is 12 amperes of current in the circuit. Using the third formula of Ohm's Law, we can determine the resistance:

$$R = E \div I$$

$$R = 12 \div 12$$

$$R = 1 \text{ Ohm (1 } \Omega \text{).}$$

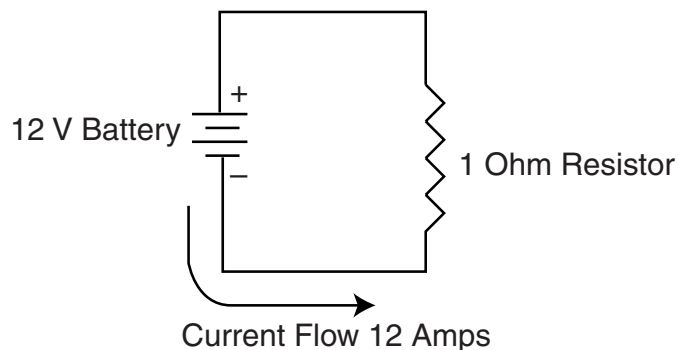

CIRCUIT CONDITIONS

A COMPLETE CIRCUIT

When current can flow from point A to point B without interruption, it is called a **complete** circuit.

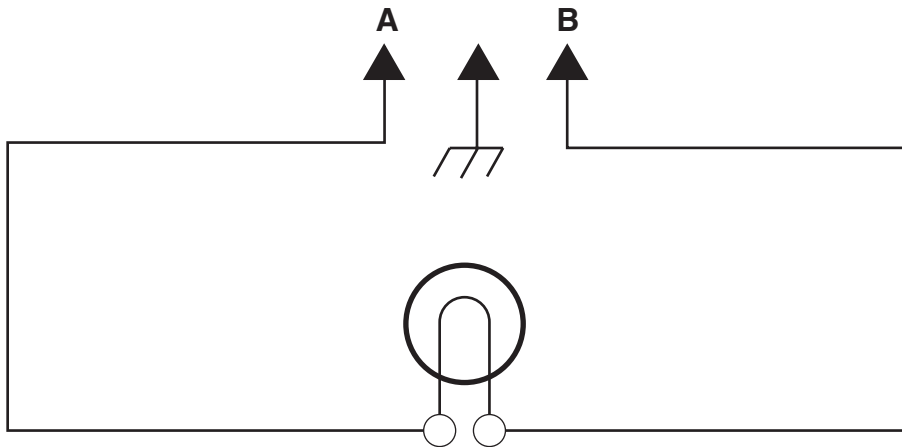

A Complete Circuit

AN INCOMPLETE CIRCUIT

If there is a break in the path, current will not be able to flow from point A to point B, and the circuit is **incomplete**. Sometimes this break in the circuit is caused by design, such as when a switch is moved to its OFF position, or it can be caused by accident, such as a break in the wire, as shown in the following illustration.

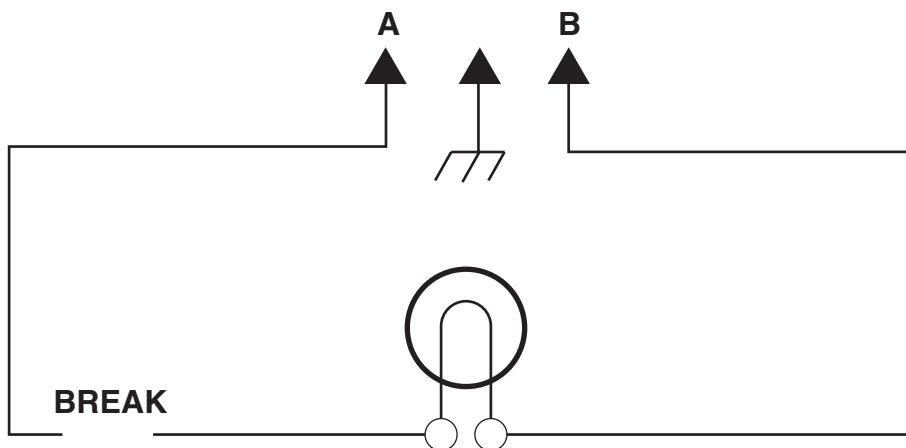

An Incomplete Circuit

AN OPEN AND CLOSED CIRCUIT

Whenever there is a break in the path through which current should flow, it is referred to as an **open** circuit (see the illustration).

A **closed** circuit is one in which there is a complete path for the current to flow (see the illustration).

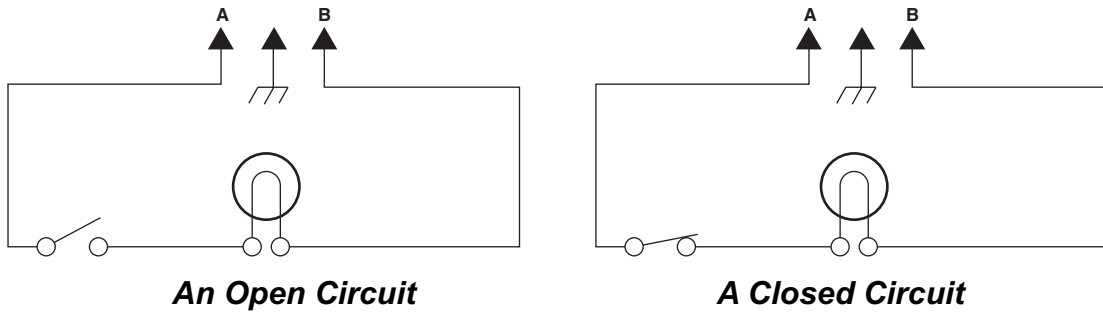

RESISTANCE IN A CIRCUIT

When **resistance**, or a load, is introduced in a circuit, it restricts the flow of current. The higher the resistance, the less current will flow. In the illustrations below, the variable resistor is used to show this effect.

Illustration A shows the variable resistor at its maximum setting, so that all of its resistance is introduced to the circuit. Thus, a minimum of current will flow, and the light is very dim.

Illustration B shows the variable resistor at its medium setting, so that only half of its resistance is introduced to the circuit. Thus, the current flow increases, and the light becomes brighter.

Illustration C shows the variable resistor at its minimum setting, so that none of its resistance is in the circuit. Thus, a maximum of current will flow, and the light is at its brightest level.

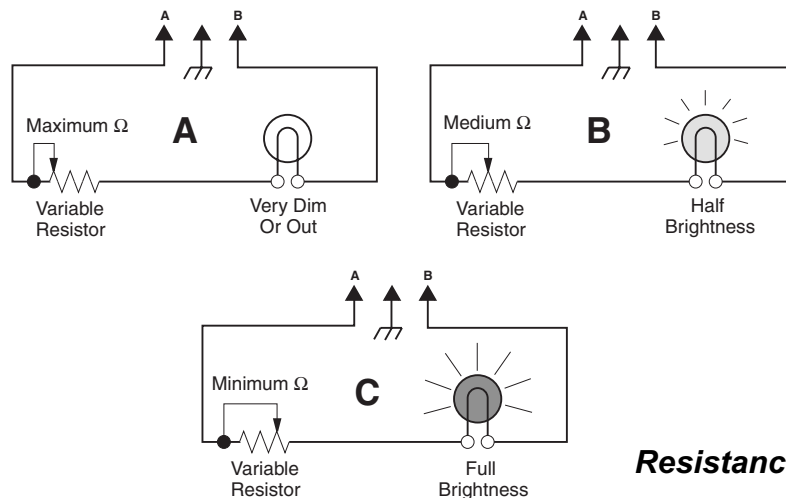

Resistance In A Circuit

TYPES OF CIRCUITS

When evaluating the operation of an electrical circuit, it is important to understand how electricity will behave in the circuit. There are three types of circuits you will encounter when diagnosing electrical systems. These types of circuits are:

1. Series circuits
2. Parallel circuits
3. Series-parallel circuits (which are combinations of the first two kinds)

These three types of circuits will be discussed next.

SERIES CIRCUIT

In a **series** circuit, components are joined together in a chain, or series, and there is only one path for current to flow. If there is a break anywhere in the circuit, current flow will be interrupted, and the circuit will stop working.

The circuit below shows a series circuit that is made up of a string of five light bulbs. Current flows from point A, through the five lights, to point B.

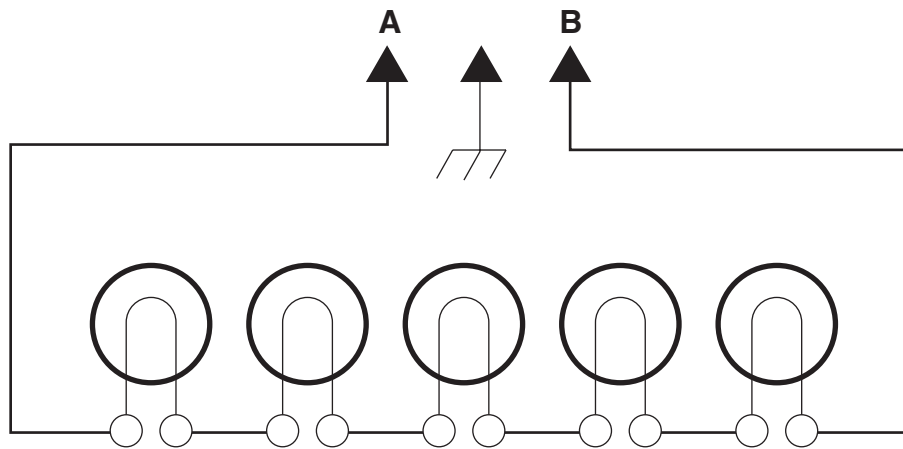

A Series Circuit

PARALLEL CIRCUIT

In a **parallel** circuit, there is more than one path for the current to flow. In the illustration, as current flows from point A to point B, it has three branches (C, D, & E) to flow through. The amount of current that will flow through each branch, depends upon the resistance of the loads in the branch. The voltage is the same across all branches in a parallel circuit.

A parallel circuit can be drawn in many different ways, as shown in the illustrations.

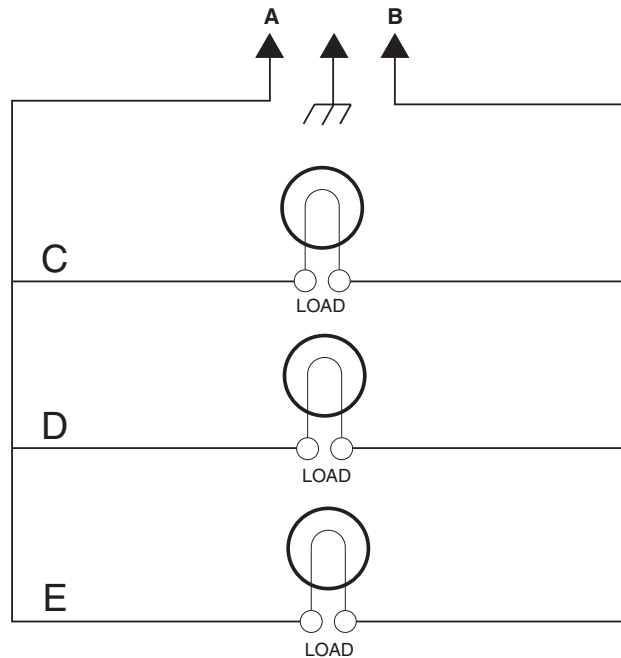

A Parallel Circuit

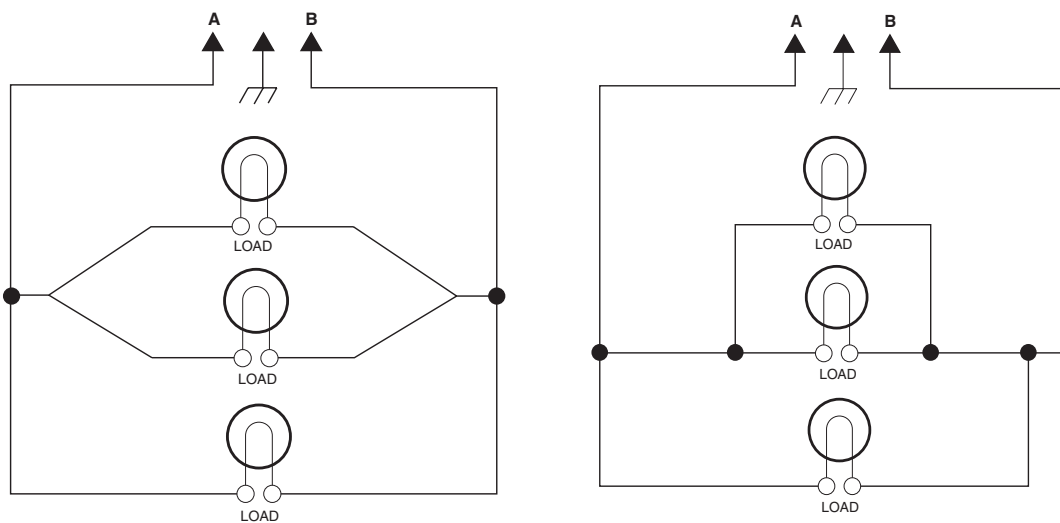

Different Types Of Parallel Circuits

SERIES-PARALLEL CIRCUIT

A **series-parallel** circuit is a combination of both series and parallel circuits.

The part of the circuit where there is only **one path** for the current to flow is the **series** part of the circuit. The part of the circuit in which there are **several paths** for current to flow, is the **parallel** part of the circuit.

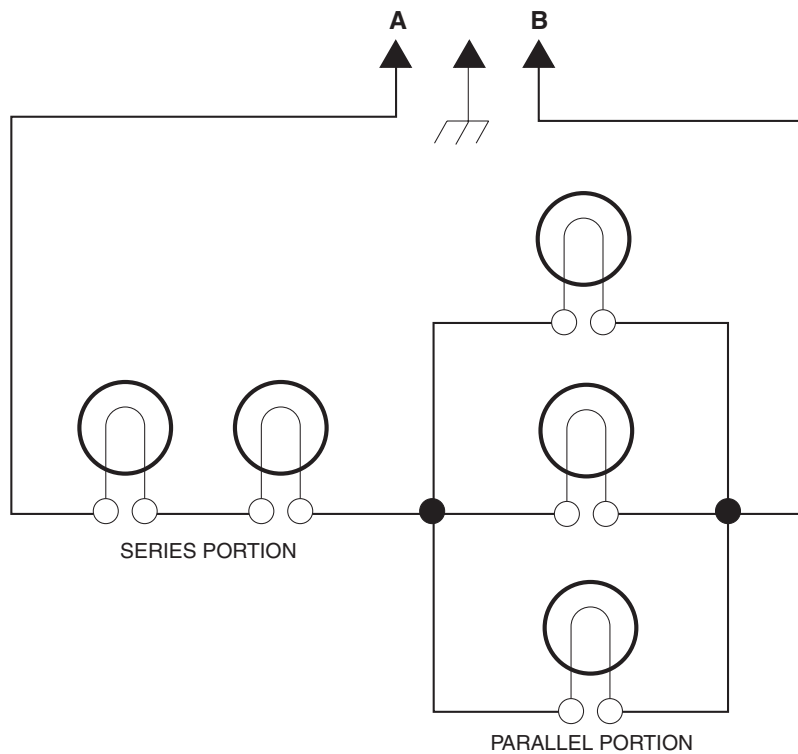

A Series-Parallel Circuit

PRACTICE EXERCISE 1

TYPES OF CIRCUITS

Look at each circuit shown below. On the line below each circuit, write whether the circuit is series, parallel, or series-parallel.

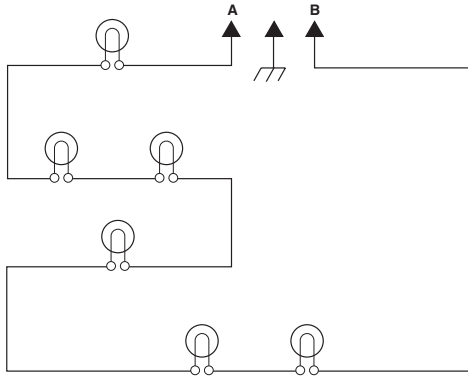

1. _____

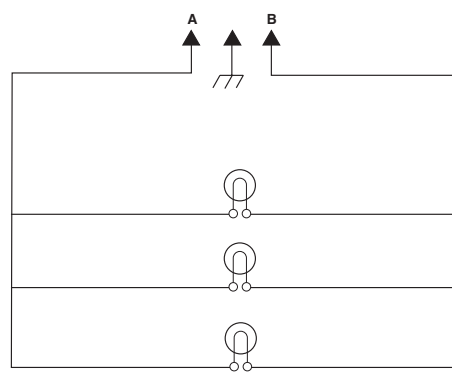

2. _____

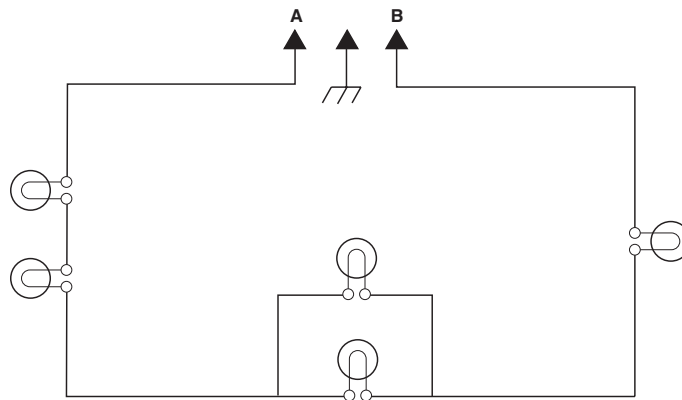

3. _____

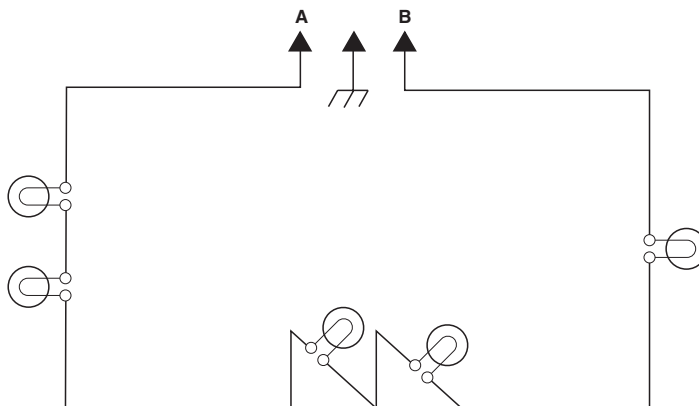

4. _____

PRACTICE EXERCISE 1 ANSWERS
TYPES OF CIRCUITS

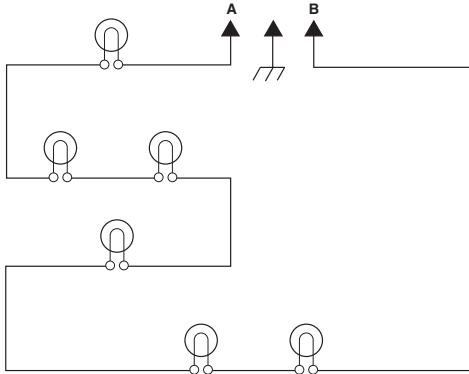

1. Series

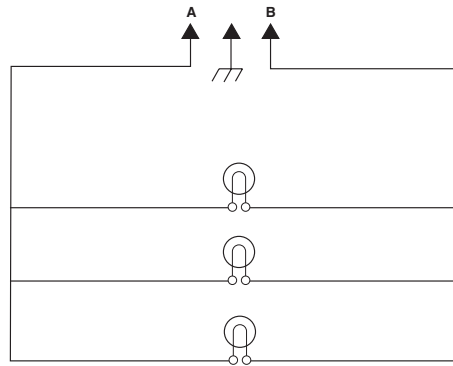

2. Parallel

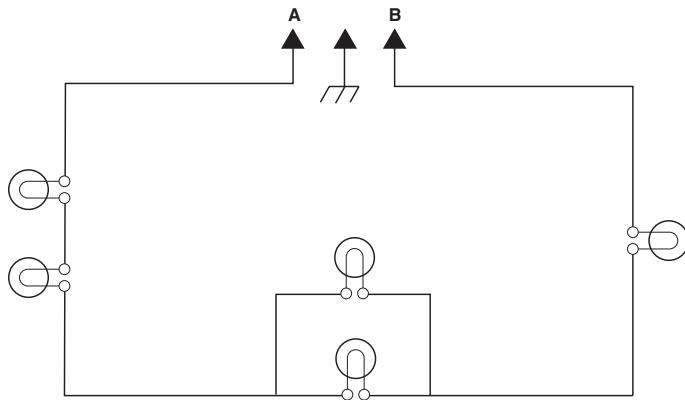

3. Series-Parallel

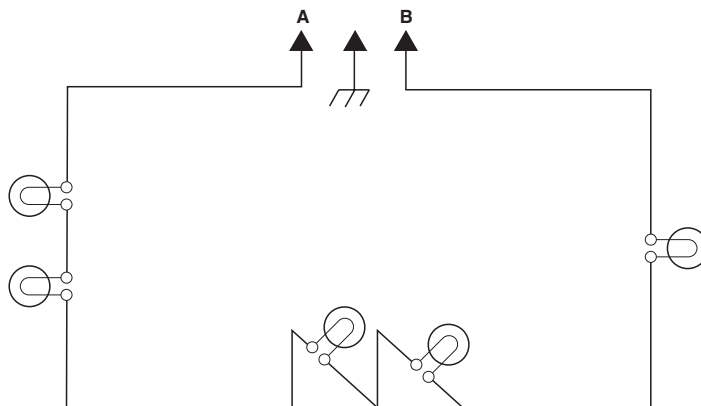

4. Series

**IF GIVEN ANSWERS AND YOURS ARE DIFFERENT,
PLEASE REVIEW THE APPROPRIATE SECTION.**

OPENS AND SHORTS

EFFECTS OF OPENS

A break in a circuit is called an **open**. The effect of an open in a series circuit is different from its effect in a parallel circuit.

In Series Circuits

An open in a series circuit will stop the flow of current in the entire circuit. In the illustration, the switch is open so that current cannot flow between points A and B.

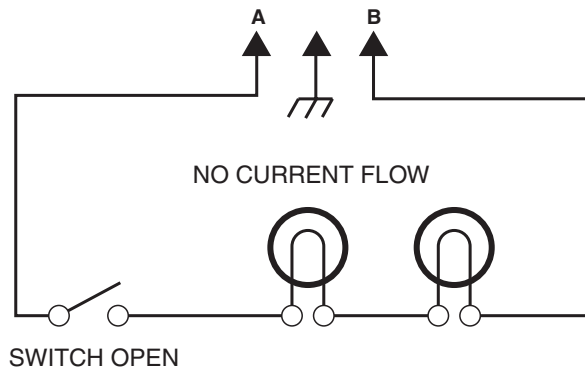

An Open Circuit (Series)

In Parallel Circuits

When there is an open in a parallel circuit, current flow will act as follows:

- a) Stops flowing through the branch with the open.
- b) Continues to flow through the other branches.

In the circuit below, current will continue to flow through load D, but not through E.

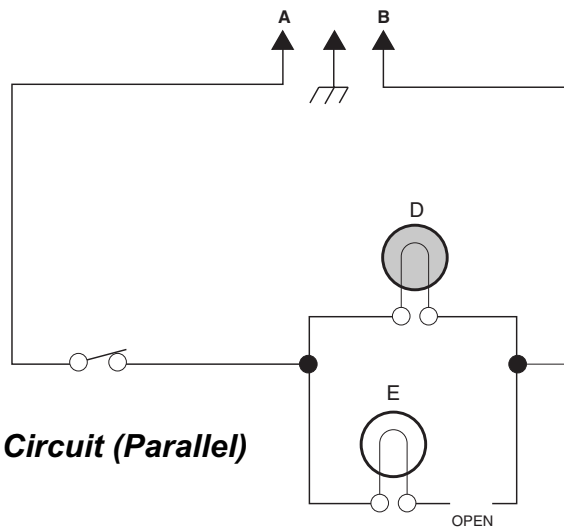

An Open Circuit (Parallel)

In Series-Parallel Circuits

If there is an open in the series portion of the series-parallel circuit, current cannot flow through any part of the circuit.

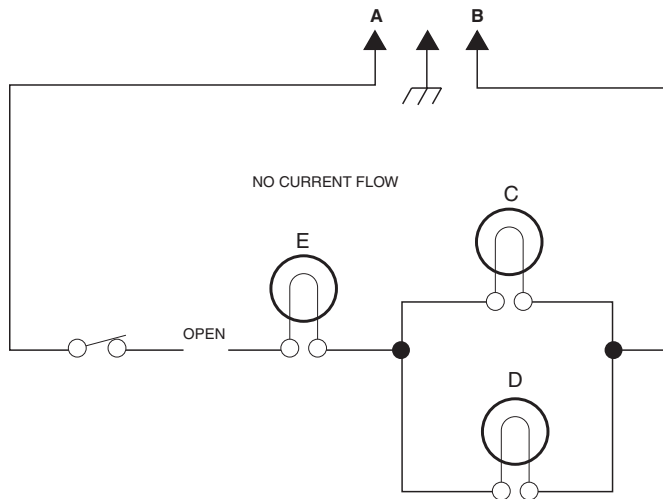

Series-Parallel Circuit With Open In Series Portion

If there is an open in a parallel portion of a series-parallel circuit, current will stop flowing through that branch, but will continue to flow through the rest of the circuit.

In the circuit below, current will flow through loads D, E, and F, but not through load G.

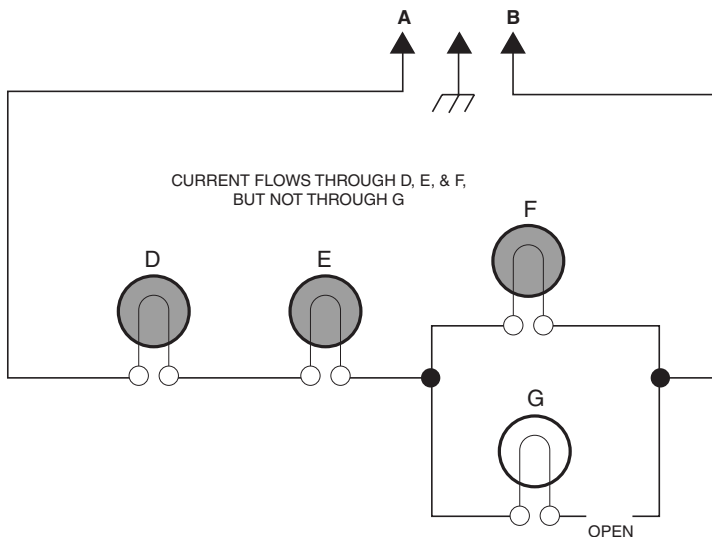

Series-Parallel Circuit With Open In Parallel Portion

EFFECTS OF SHORTS

The term **short** means a direct circuit across an electrical source that provides a zero resistance path for the current to flow.

In Series Circuits

The circuit below shows a wire short across load C. This short causes all of the current to flow through the wire instead of the load, because the wire offers the path of least resistance.

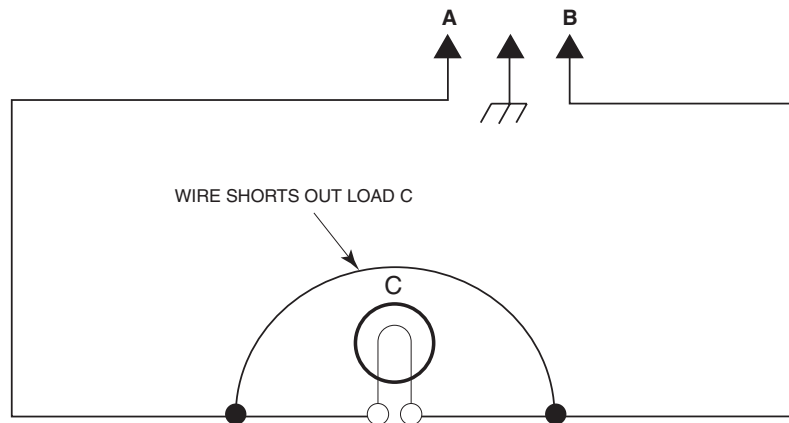

Wiring Short In Series Circuit

It is also possible for a portion of a circuit to be shorted where one or more of the loads are bypassed. This type of short is referred to as a “shunt” and is usually designed into the circuit. The difference between a “short” and a “shunt” is:

- A short offers no resistance to the flow of current in a circuit.
- A shunt causes a bypass around a load, but the circuit will still offer resistance to the flow of current.

Example 1: If a short is connected between points C and D, loads E, F, and G would be bypassed because they are shorted out of the circuit.

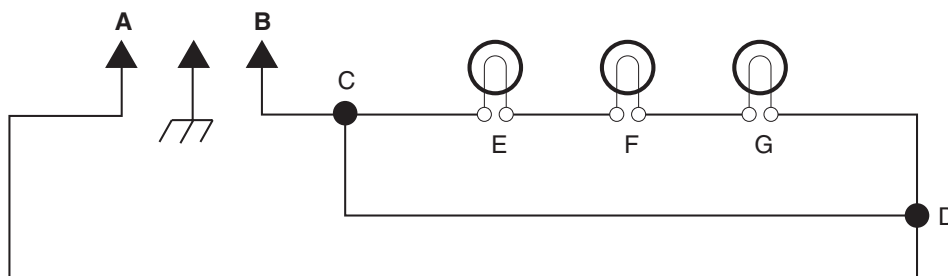

A Series Circuit With A Short Across 3 Loads

Example 2: If a permanent shunt is connected between points C and D, loads F, and G would be bypassed because they are shorted out of the circuit.

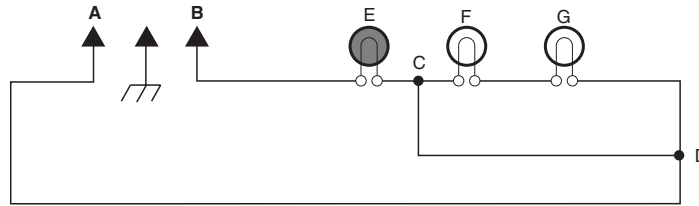

A Series Circuit With A Permanent Shunt Across 2 Loads

Example 3: If a load is designed to be turned on and off, a temporary shunt is used. Closing switch X shorts out load G and turns it off.

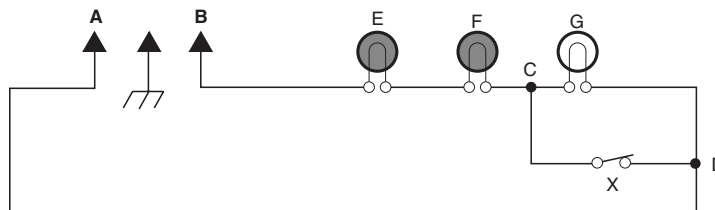

A Series Circuit With A Temporary Shunt Across 1 Load

In Parallel Circuits

The circuit below shows a parallel circuit. Current flow will be from Point A, through loads C and D, to point B.

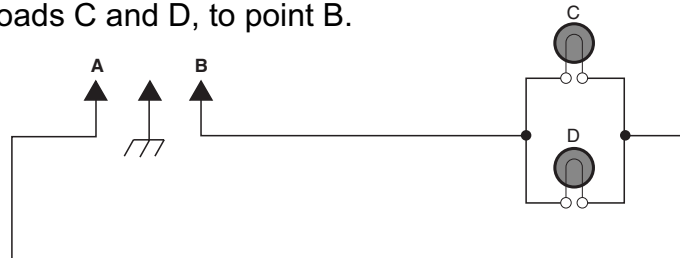

Parallel Circuit

The circuit below shows a wire shorted between points X and Y, which shorts out loads C and D. In this case, current will flow from Point A, through the wire short across loads C and D, and back to point B. The current flows through the wire instead of the loads because the wire offers the path of least resistance.

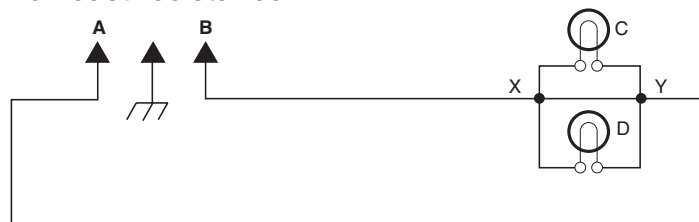

Parallel Circuit With Short

In Series-Parallel Circuits

In the circuit below, current will flow from point A, through the short from point C to point D, bypass loads E, F, G, and H, and back to point B. The current will bypass all four loads because it will follow the path of least resistance through the wire.

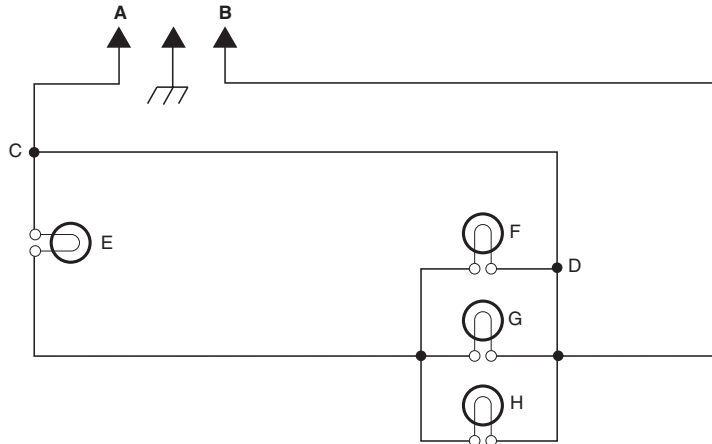

Series-Parallel Circuit With Short

In the series portion of the circuit below, current will flow from point A, through load C. In the parallel portion of the circuit, current will flow through the wire across load D, and back to point B. The current will bypass all three loads because it will follow the path of least resistance through the wire.

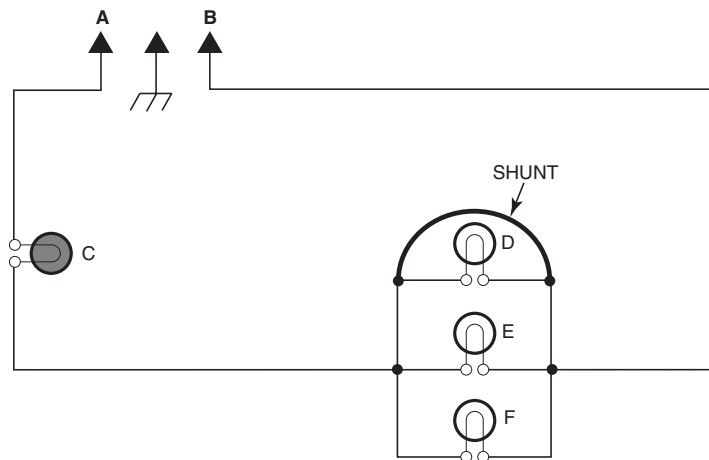

Series-Parallel Circuit With A Shunt

PRACTICE EXERCISE 2 OPENS AND SHORTS

In the space to the right of the circuit:

- Name the kind of circuit shown.
 - Write whether component X is open, shorted, or okay, as described in each condition.
 - Write the name of the loads that are still working.
1. **CONDITION:** Points P & Q read zero ohms in both OPEN and CLOSED positions.

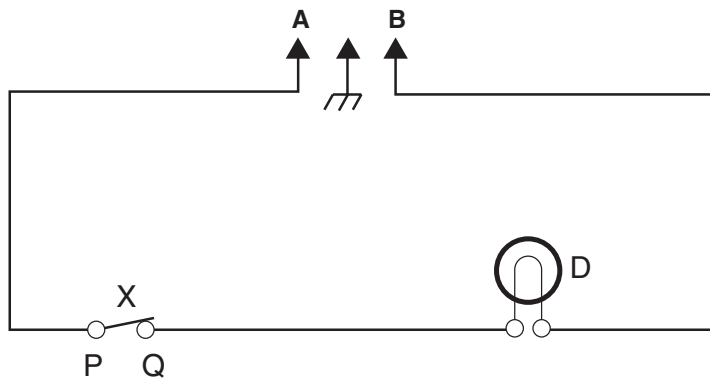

_____ *type of circuit*

_____ *switch X is (open, shorted, or OK)*

_____ *loads working*

2. **CONDITION:** When one end of load X is disconnected and checked with an ohmmeter, it measures infinite resistance.

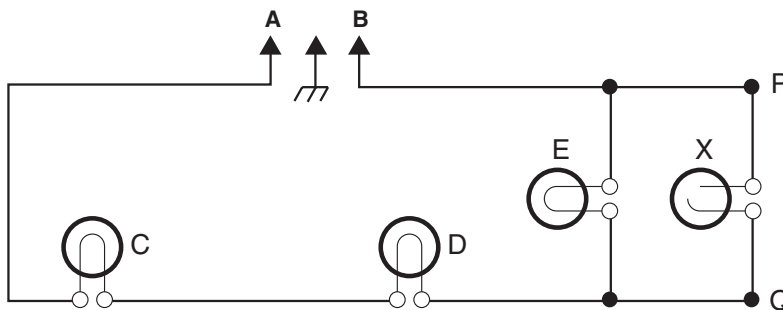

_____ *type of circuit*

_____ *load X is (open, shorted, or OK)*

_____ *loads working*

3. **CONDITION:** Loads W, Y, & Z work if X is in the OFF (OPEN) or the ON (CLOSED) position.

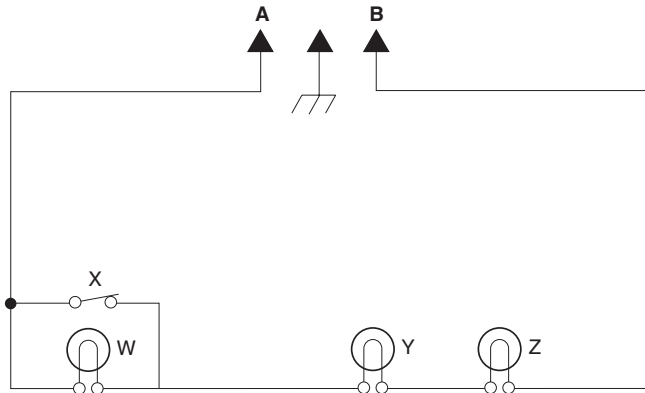

type of circuit

switch X is (open, shorted, or OK)

when X is closed, what loads are working

4. **CONDITION:** When points G and J read infinite resistance.

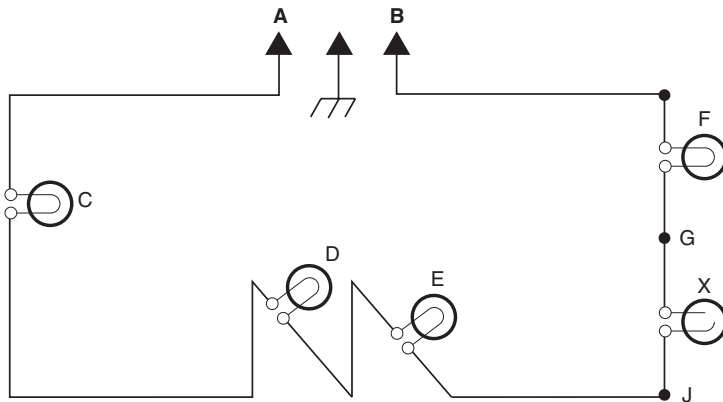

type of circuit

load X is (open, shorted, or OK)

loads working

5. **CONDITION:** When points P and Q read zero ohms in the ON position, infinite resistance in the OFF position.

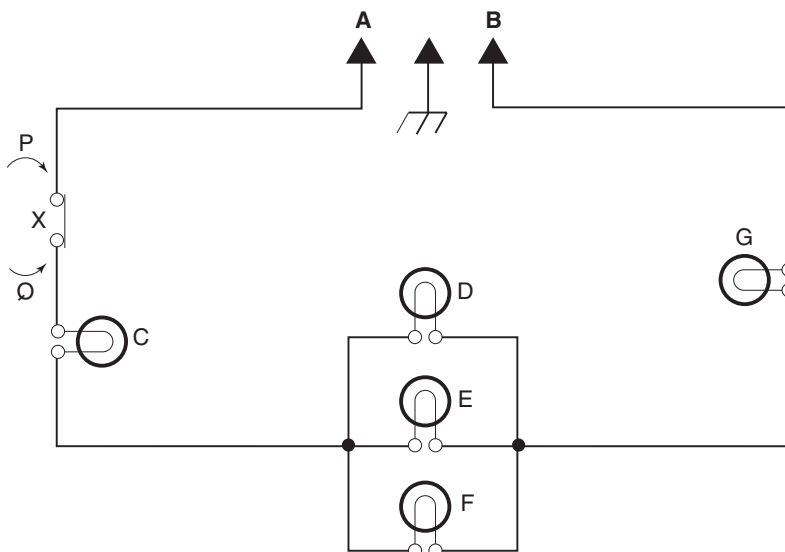

type of circuit

switch X is (open, shorted, or OK)

loads working as shown in diagram

PRACTICE EXERCISE 2 ANSWERS
OPENS AND SHORTS

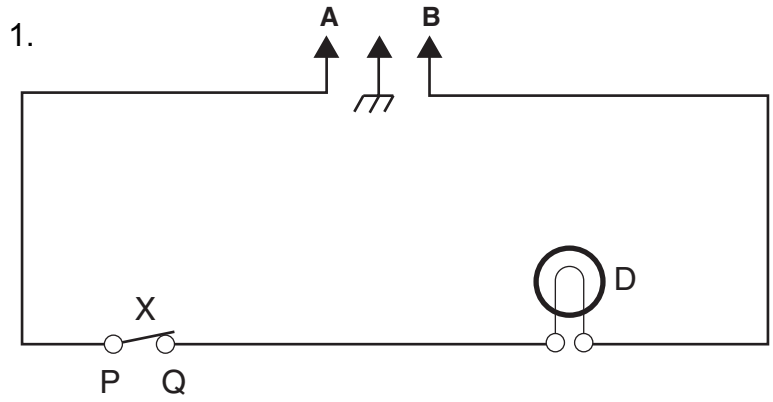

Series

type of circuit

X is shorted

switch X is (open, shorted, or OK)

D is working

loads working

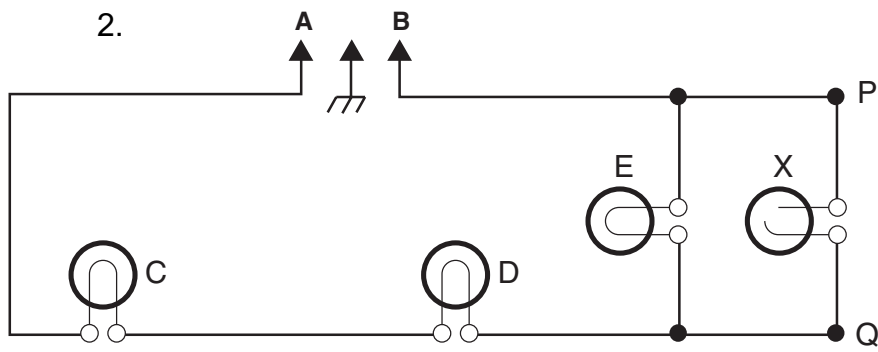

Series-Parallel

type of circuit

X is open

load X is (open, shorted, or OK)

C, D, & E are working

loads working

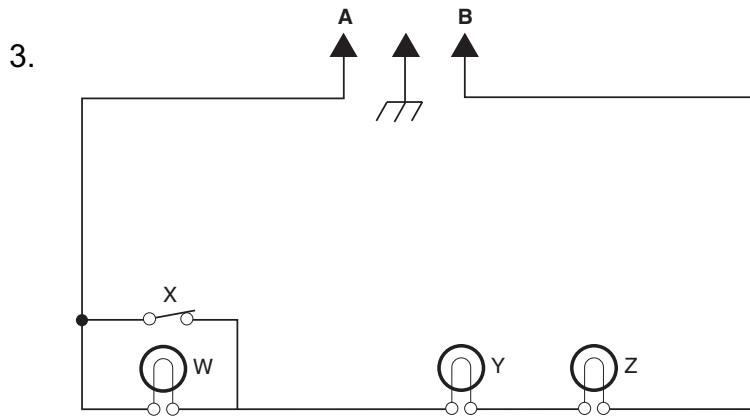

Series

type of circuit

X is open

switch X is (open, shorted, or OK)

Y & Z

when X is closed, what loads are working

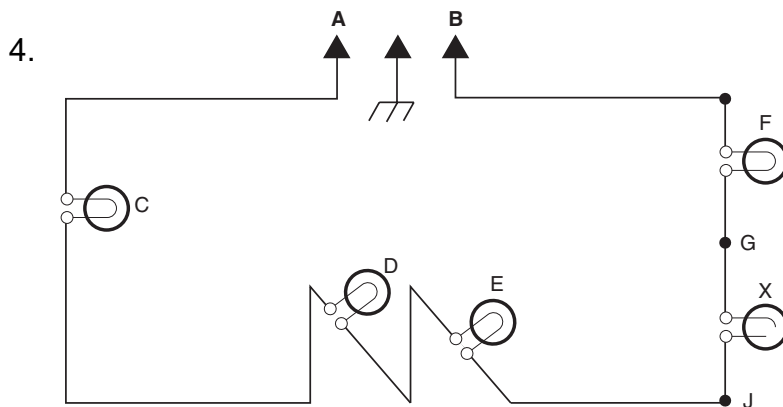

Series

type of circuit

X is open

load X is (open, shorted, or OK)

No loads working

loads working

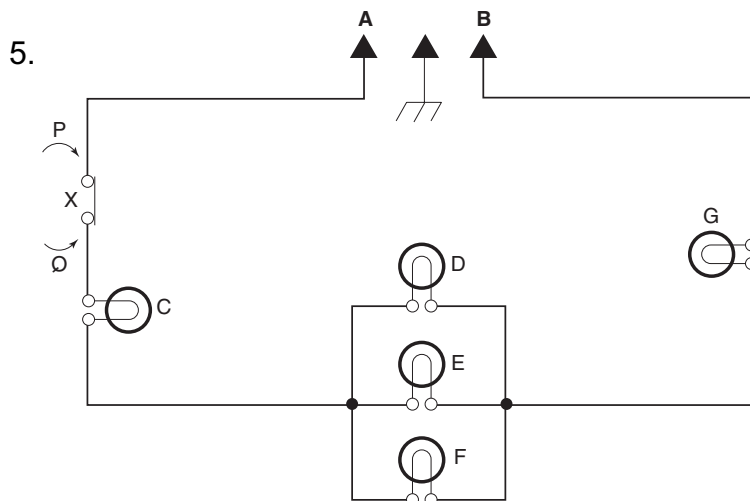

Series-Parallel

type of circuit

X is OK

switch X is (open, shorted, or OK)

All loads working

loads working as shown in diagram

**IF GIVEN ANSWERS AND YOURS ARE DIFFERENT,
PLEASE REVIEW THE APPROPRIATE SECTION.**

— NOTES —

SECTION 2

WIRING DIAGRAMS

INTRODUCTION

A wiring diagram is a convenient way of showing which components are present in an appliance, and how those components are connected together electrically.

Just as a road map helps you to get where you're going, a wiring diagram helps you follow current flow and identify problems.

It is important to realize that wiring diagrams, or "schematics," identify electrical connections and current flow, but they do not represent actual locations, distances apart, or component placement (unless noted on the drawing). Nor are they drawn to scale. They do tell you what components are used and how the electricity should flow.

In this section we will be reviewing wiring diagrams for a typical range, dishwasher, and microwave oven.

WIRING DIAGRAM TERMS

A GLOSSARY OF WIRING DIAGRAM TERMS USED BY WHIRLPOOL

TERM	DESCRIPTION
N.O.	Normally-Open Terminal
N.C.	Normally-Closed Terminal
COM	Common Terminal
L1	Hot Side of 120 or 240 VAC Electrical Circuit (usually BK)
L2	Hot Side of 240 VAC Electrical Circuit (usually R)
N	Neutral Line (usually W)
GND	Chassis Ground (usually G)
S.P.S.T.	Single Pole Single Throw Switch
S.P.D.T.	Single Pole Double Throw Switch
LF	Left Front
RF	Right Front
CR	Center Rear
LR	Left Rear
RR	Right Rear
P1-3	Connector Plug and Terminal Designator (e.g. Connector P1-Terminal 3)
DLB	Double Line Break Relay

WIRING DIAGRAM COLORS

A GLOSSARY OF WIRE COLOR TERMS USED BY WHIRLPOOL

TERM	COLOR
W	White
T	Tan
BK	Black
R	Red
Y	Yellow
BL or BU	Blue
O or OR	Orange
G or GN	Green
P	Purple
BR	Brown
GR or GY	Gray
DB or DBU	Dark Blue
LB or LBU	Light Blue
PK	Pink
V or VT	Violet











NOTE: The following terms are for multi-colored wires. The first letter designates the overall color of the wire, and the second letter designates the color of the tracer (stripe) on the wire.

T-R	Tan w / Red Tracer
G-BK	Green w / Black Tracer
O-BK	Orange w / Black Tracer
R-W	Red w / White Tracer
W-R	White w / Red Tracer
BU-O	Blue w / Orange Tracer
W-G	White w / Green Tracer
BR-W	Brown w / White Tracer
Y-BL	Yellow w / Blue Tracer
W-V	White w / Violet Tracer

WIRING DIAGRAM SYMBOLS

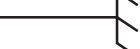
A GLOSSARY OF SYMBOLS USED BY WHIRLPOOL

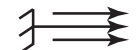





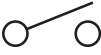
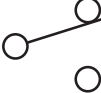

LINES & CONNECTORS

Integral conductor	
Crossover	
Crossover	
Shield	
Permanent Connection	
Terminal	
Ground (Earth)	
Ground (Chassis)	
Plug Connector	
Grounded Service Cord (3 Prong)	
Mechanical Connection	

MECHANICAL SWITCHES

Single Pole, Single Throw (S.P.S.T.)	
Single Pole, Double Throw (S.P.D.T.)	

MECHANICAL & MANUAL SWITCHES

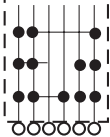
Single Pole, Double Throw (S.P.D.T.) 2 Contacts on One Side	
Multi-Position	
Pushbutton (N.O.) Momentary Contact	
Pushbutton (N.C.)	
Pushbutton (2-Circuit)	
Timer Switch	
Pressure Operated (S. P. D.T.)	
Centrifugal Switch	
Master or Control Sw. (Number of Positions & Internal Contact Operation as Required)	

TEMPERATURE-ACTUATED COMPONENTS

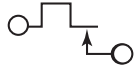
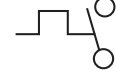
S.P.S.T. - Open on Heat Rise	
S.P.S.T. - Close on Heat Rise	

TEMPERATURE-ACTUATED COMPONENTS

NOTE: The symbols shown are for thermostats, bimetal switches, overload protectors, or other similar components.

Temperature-Actuated
Close on Heat Rise



Temperature-Actuated
Open on Heat Rise

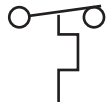

S.P.S.T. - Open on Heat Rise

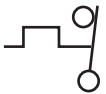

S.P.D.T.

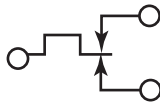

S.P.D.T.

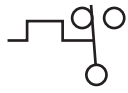

S.P.S.T. - 2-Contacts

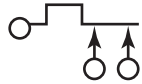

S.P.S.T. - Adjustable
Close on Heat Rise



S.P.D.T. - Adjustable



S.P.S.T. - Adjustable
Open on Heat Rise



S.P.S.T. - With Internal Heater
Close on Heat Rise

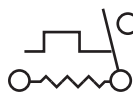

S.P.S.T. - With Internal Heater
Open on Heat Rise

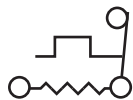

COMBINATION DEVICES

Relay-Magnetic
(Arrangement of Con-
tacts, As Necessary To
Show Operation)

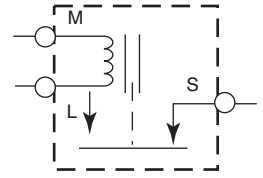

Relay-Thermal
(Arrangement of Con-
tacts, As Necessary To
Show Operation)

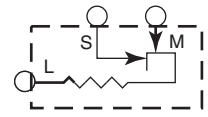

Timer (Defrost)

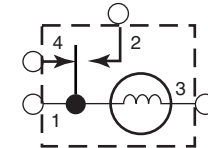

LIGHTS

Incandescent

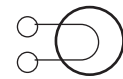

Neon



Fluorescent



MOTORS

Timer



Single-Speed

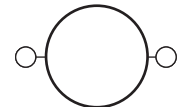

2-Speed

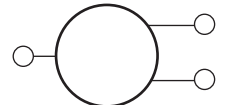

3-Speed

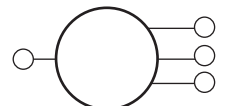

MOTORS

Internal Motor- Internal Circuitry May Be Shown, If Required

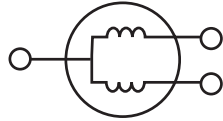

Compressor Motor

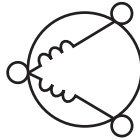

Single-Speed Motor

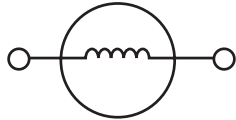

Two-Speed Motor

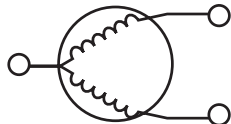

Three-Speed Motor

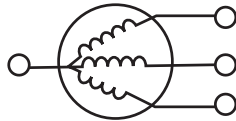

Multi-Speed Motor - Internal Circuitry May Be Shown, If Required

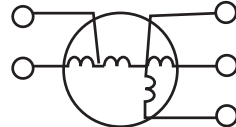

Circuit Breaker



Iron Core Coil (Solenoid)



Coil



NOTE: Coils may also be shown with open loops, as in the following examples.

Coil (Solenoid)



Coil



Fuse



Heater or Resistor

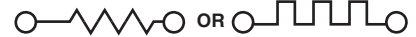

Humidistat



MISCELLANEOUS

Auto-Starter



Relay

NOTE: Use symbols for coil and switches and show separately in circuit.

Ballast



Transformer



Bell



Buzzer

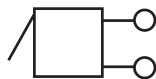

Adjustable Component (Arrow Drawn Through Component at Approximately 45°)



Non-Polarized Capacitor— Circuit Polarity Does Not Apply

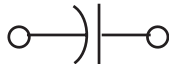

Polarized Capacitor— Correct Polarity Applies

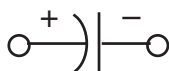

SOLID STATE DEVICES

Solid state devices are being used in modern home appliances. When required, the function of these devices is explained in the training program covering the product in which they are used.

The solid state devices shown below are some of the more common types being used in appliances today.

Thermistor — An input device that changes resistance with temperature so the microcomputer can respond accordingly.

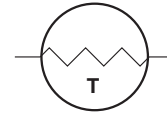

Diode — Permits current flow in one direction only.



Triac — An electronic device that is similar to a diode, except that it allows current to flow in both directions, as with alternating current (AC).

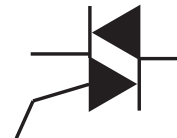







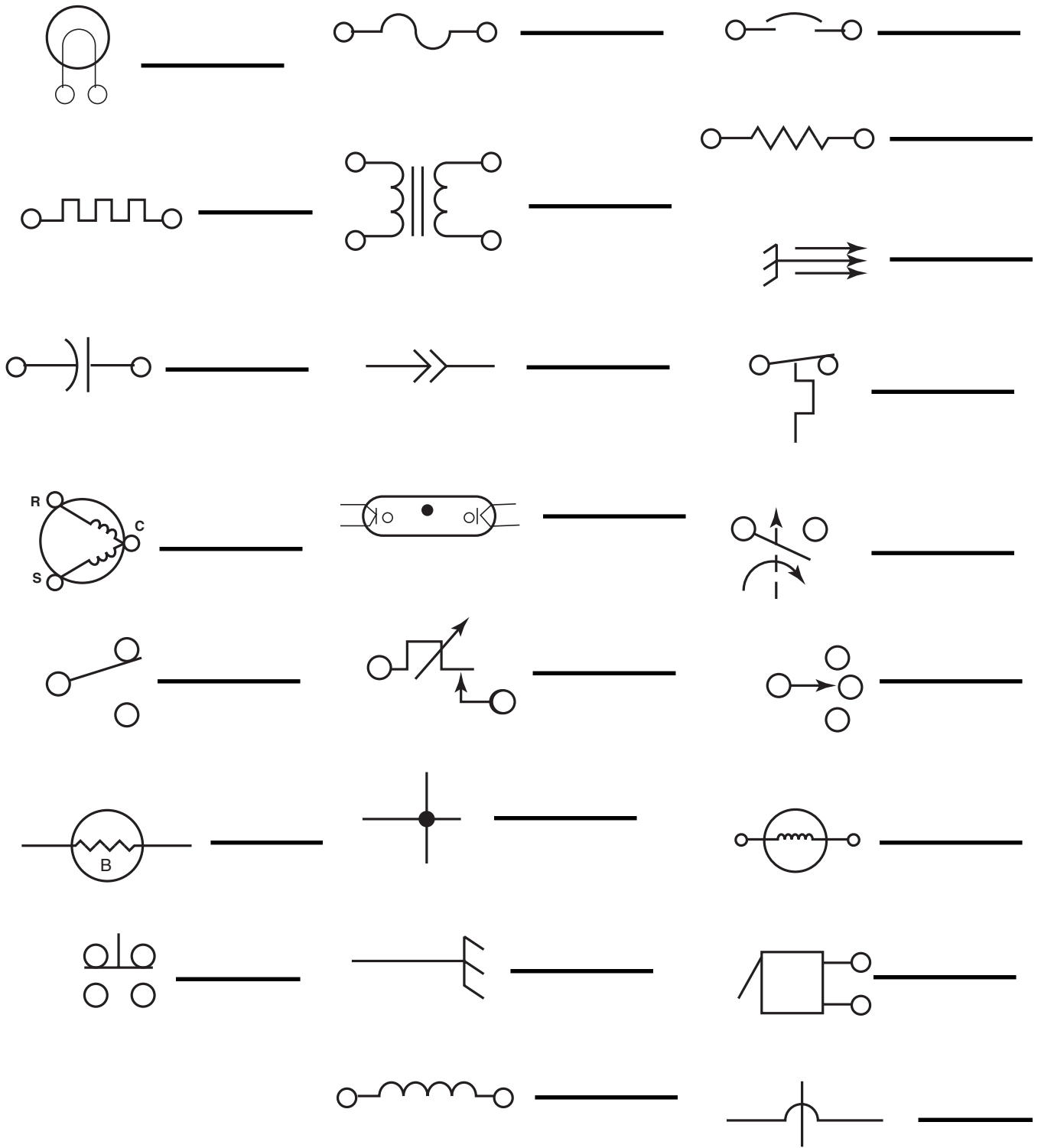



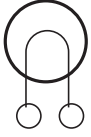



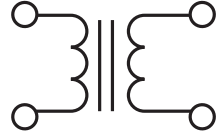

PRACTICE EXERCISE 1 IDENTIFYING COMPONENTS

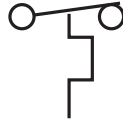
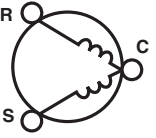
Place the numbers on the lines beside the symbols on the next page to make the proper match.

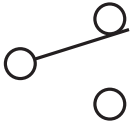
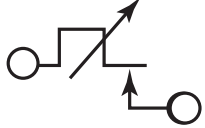
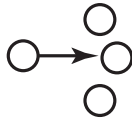
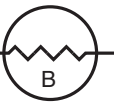
- | | |
|--|---------------------------|
| 1. Compressor | 14. Centrifugal Switch |
| 2. Crossover | 15. Plug Connector |
| 3. Ballast | 16. Resistor or Heater |
| 4. Permanent Connection | 17. Fuse |
| 5. Adjustable Buzzer | 18. Multi-Position Switch |
| 6. Incandescent Lamp | 19. Coil |
| 7. Fluorescent Lamp | 20. Circuit Breaker |
| 8. Heat Rise Thermostat | 21. Heater |
| 9. Adjustable Thermostat | 22. Capacitor |
| 10. Chassis Ground | 23. Pushbutton (S.P.D.T.) |
| 11. Transformer | 24. Single-Speed Motor |
| 12. Grounded Service Cord | |
| 13. Single-Pole, Double-Throw
(S.P.D.T.) Switch | |

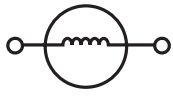
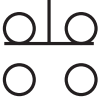

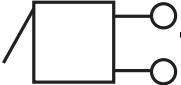
PRACTICE EXERCISE 1 ANSWERS
IDENTIFYING COMPONENTS

	6		17		20
	21		11		16
	22		15		8
	1		7		14
	13		9		18
	3		4		24
	23		10		5
			19		2

**IF GIVEN ANSWERS AND YOURS ARE DIFFERENT,
PLEASE REVIEW THE APPROPRIATE SECTION.**

PRACTICE EXERCISE 2 LOCATING COMPONENTS

Locate, circle, and number the listed components in the wiring diagram.

1. Permanent Connection
2. Fuse
3. Thermostat
4. Triac
5. Thermistor
6. Overfill Switch
7. Plug Connector
8. Pushbutton Switch
9. Chassis Ground
10. Grounded Service Cord
11. Resistor

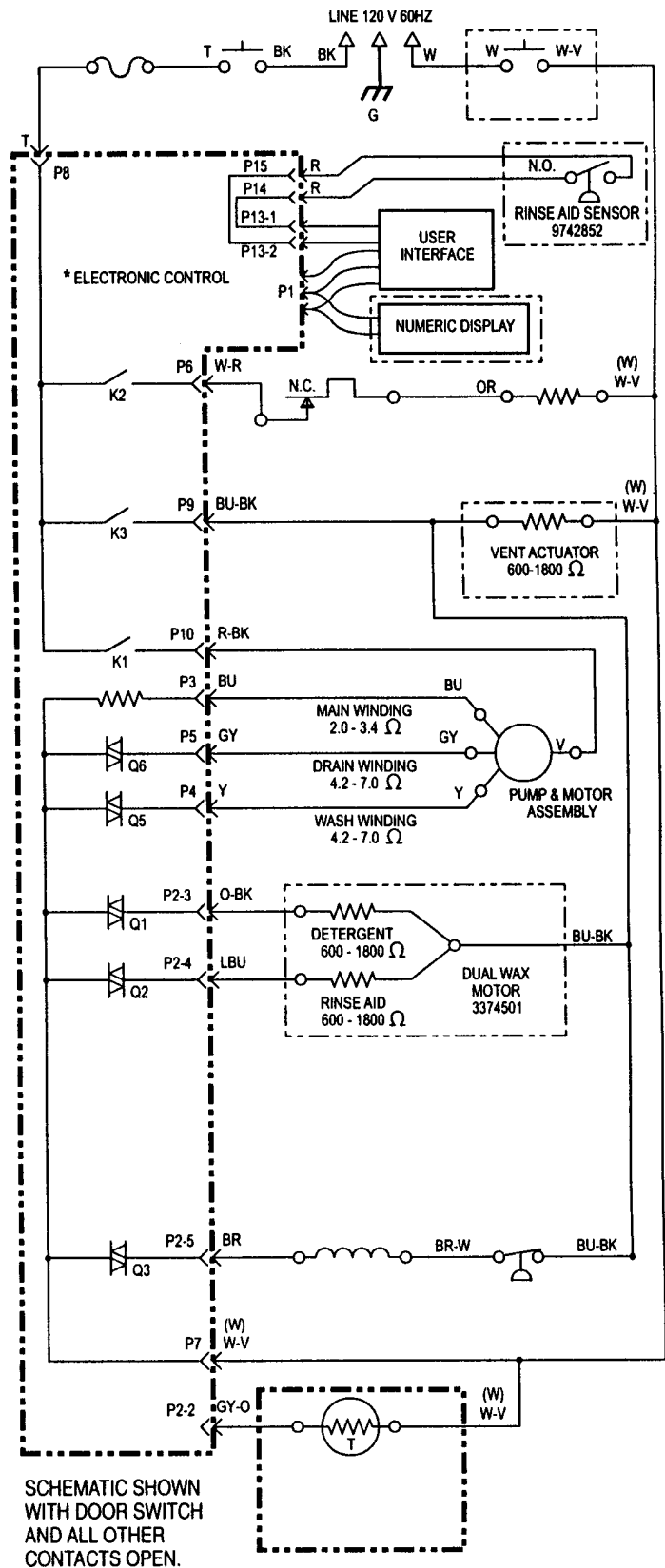

TRACING CIRCUITS

Tracing circuits is a critical tool in diagnosing appliance problems. If you are able to understand how an appliance functions during a specific cycle, it will help you in tracing out the active circuits for diagnosis.

Tracing a circuit is easy to do. It is somewhat the same as solving a “maze” puzzle, like the one shown below. Tracing a path for the bee to reach the hive is like tracing an active circuit from one side of the supply line (L1) to the other (Neutral). There are numerous directions that you can go, just like in the maze below. However, sometimes an obstacle is in the way, and blocks the path. Good circuit diagnosis will help uncover the obstacle so that it can be removed.

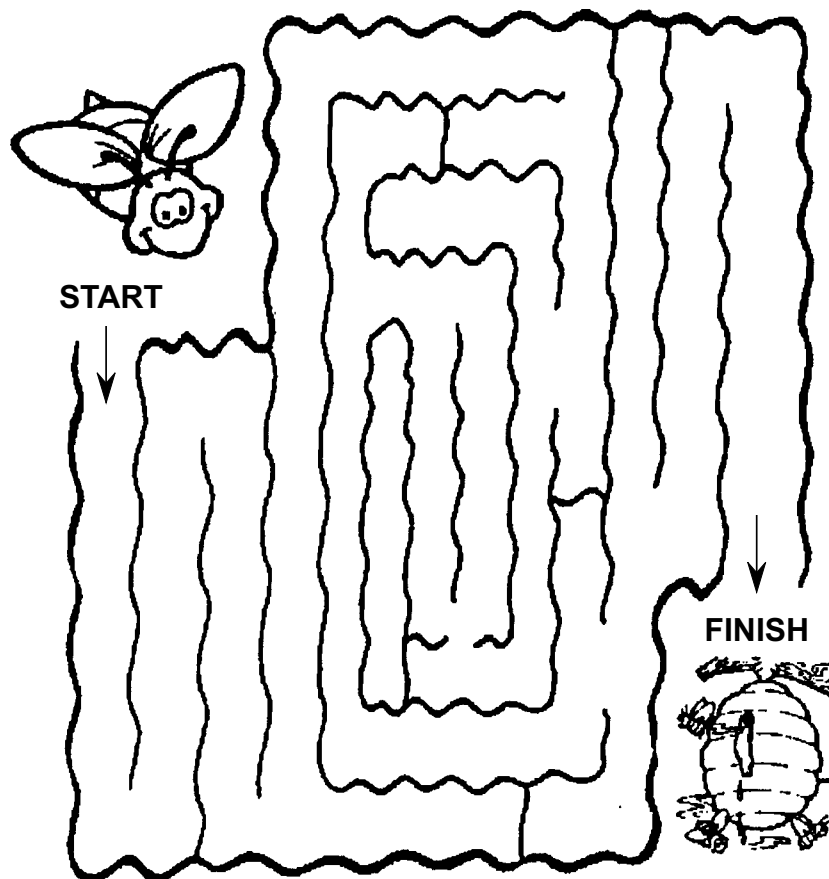

Here's how to do it. First, draw through the switches you want to show closed in the circuit. Then, begin at the left side of the power source, and trace your way around through closed switches and loads, and back to the other side of the power source. This will tell you which loads are operating for the switch settings you chose. Knowing which switches to “close” is the key to making sense of a circuit.

NOTE: A shaded line will be used to show the path of current flow.

Example: Start at point A and trace down to the switch. Since the switch is open, current cannot flow through it. But there is a parallel circuit that goes through the motor. Trace through the motor to the other side of the circuit. The motor will run, but the light will be off, because of an open switch. If the switch is closed, the light will light, and the motor will run.

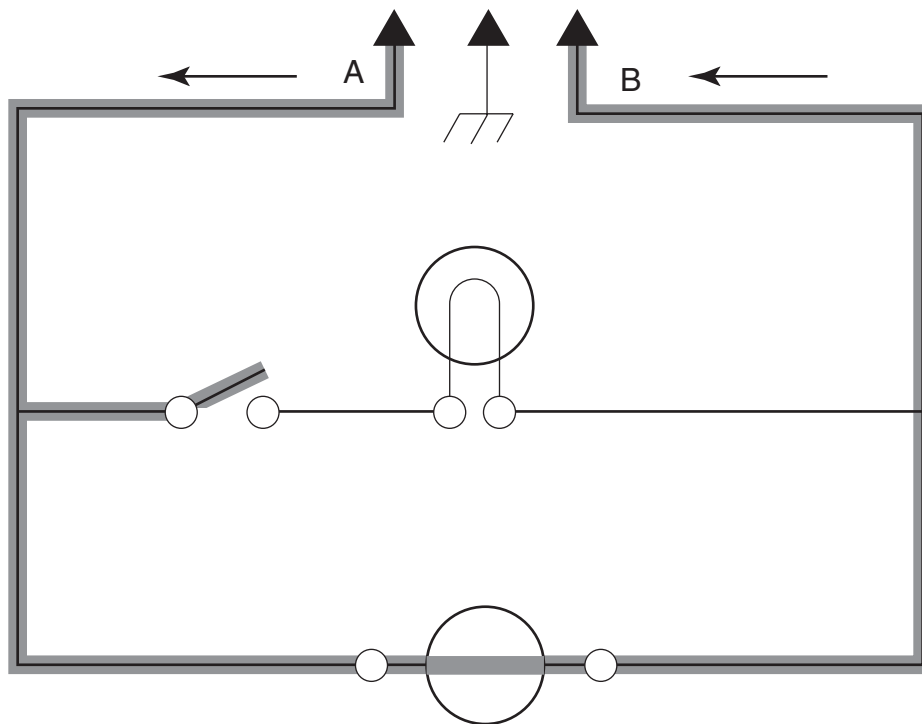

Example: Here is another circuit. You can see that since switch X is open, current cannot flow past that point, so neither load can be energized (turned on).

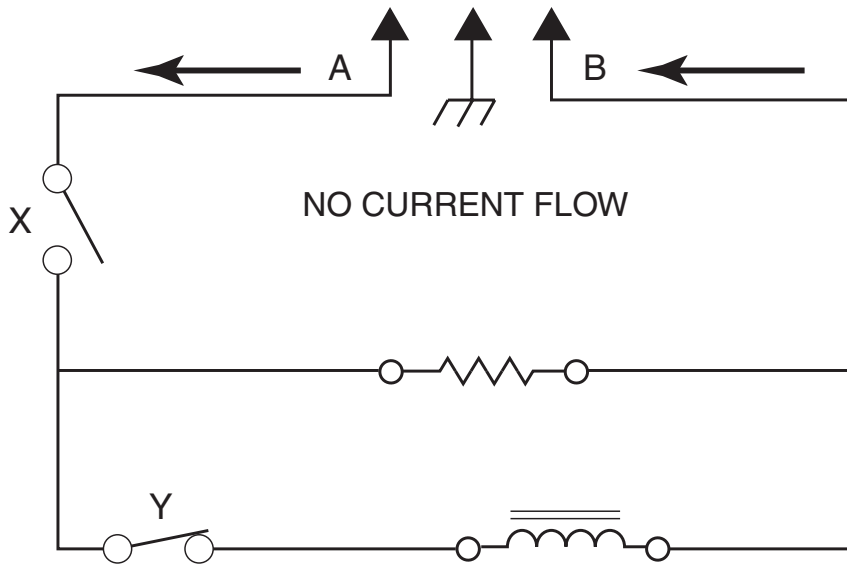

When switches X and Y are closed, the shaded parts of the circuit are energized, starting at point A, and working around to point B.

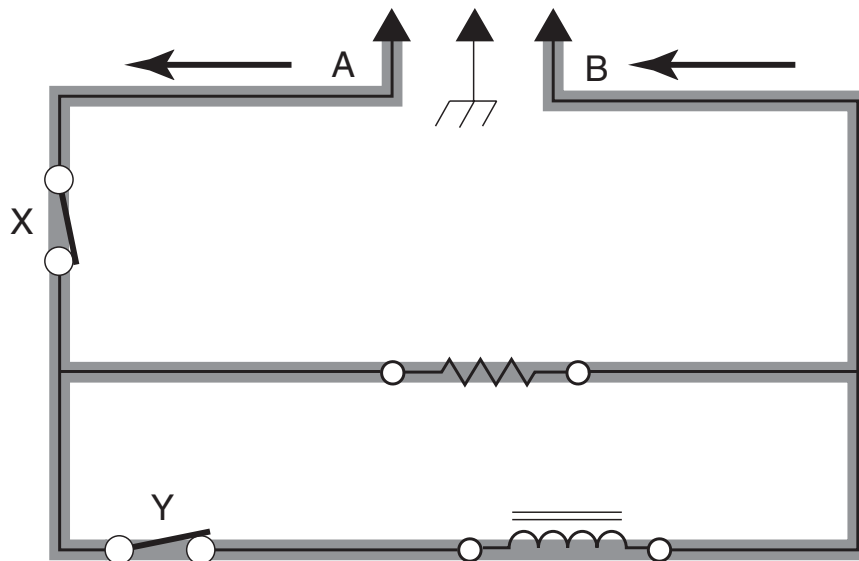

PRACTICE EXERCISE 3 TRACING CIRCUITS

Start at point A and draw a wavy line through the closed circuit(s) until you reach point B.

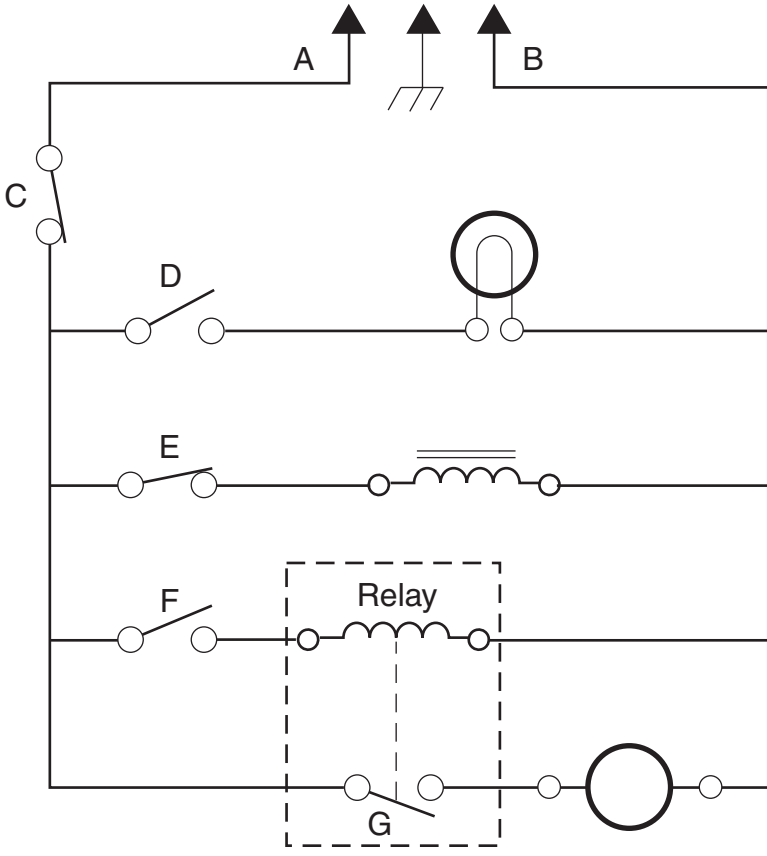

PRACTICE EXERCISE 3 ANSWERS TRACING CIRCUITS

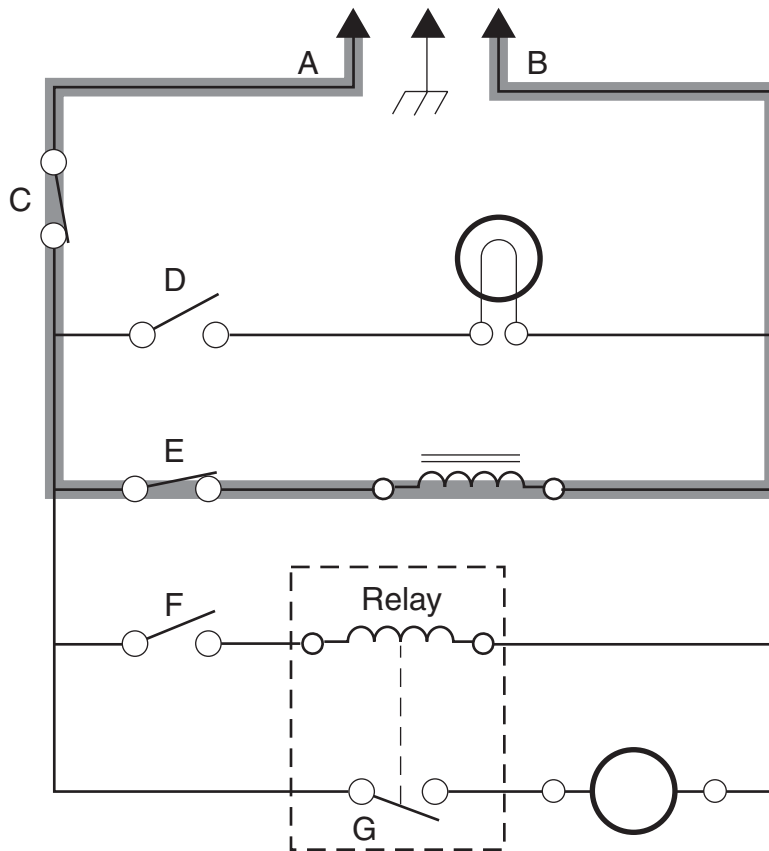

Current flows through switch C.

Switch D is open, so the light will not turn on.

Switch E is closed, so the solenoid will be energized.

Switch F is open, so the relay will not be energized.

Since the relay is not energized, relay contact G remains open, and the motor will not be energized.

***IF GIVEN ANSWERS AND YOURS ARE DIFFERENT,
PLEASE REVIEW THE APPROPRIATE SECTION.***

TECH NOTES

The technician must know how the appliance works. Look for special notes on wiring diagrams.

- Switches and contacts that are closed.
- Color codes.
- Door position.
- Other information that can be helpful.

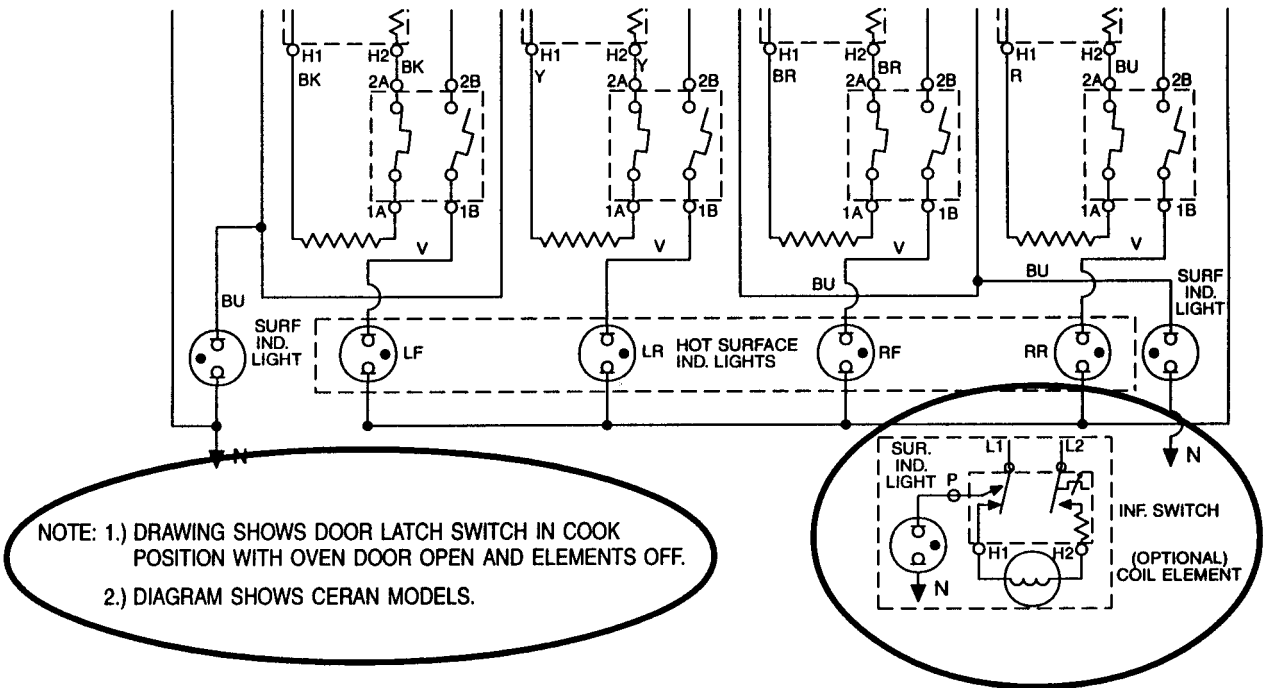

RELAY LOGIC

RELAY LOGIC KEY

- - OFF
- × - ON
- + - CYCLING (MAX PERIOD = 60 SEC)
- ⊗ - ON OR OFF

MODES	RELAYS						
	BAKE	IN BR	OUT BR	** CONV ELEM	** CONV FAN	OV LT	BLOWER
OFF	○	○	○	○	○	⊗	⊗
■ PREHEAT-BAKE	+	+	+	○	○	⊗	×
BAKE 24",30"	■	+	+	○	○	⊗	×
BAKE 27"	■	+	+	○	○	⊗	×
ECONO BROIL	○	×	○	○	○	⊗	×
MAXI BROIL	○	×	×	○	○	⊗	×
CONV BROIL	○	×	×	○	×	⊗	×
● PREHEAT-CONV	+	+	+	○	×	⊗	×
CONV ROAST 24" ●	×	○	×	○	×	⊗	×
CONV ROAST 27",30" ●	×	+	×	○	×	⊗	×

PRACTICE EXERCISE 4 TRACING CIRCUITS

Use a marking pen and trace the series circuit during the BROIL cycle.

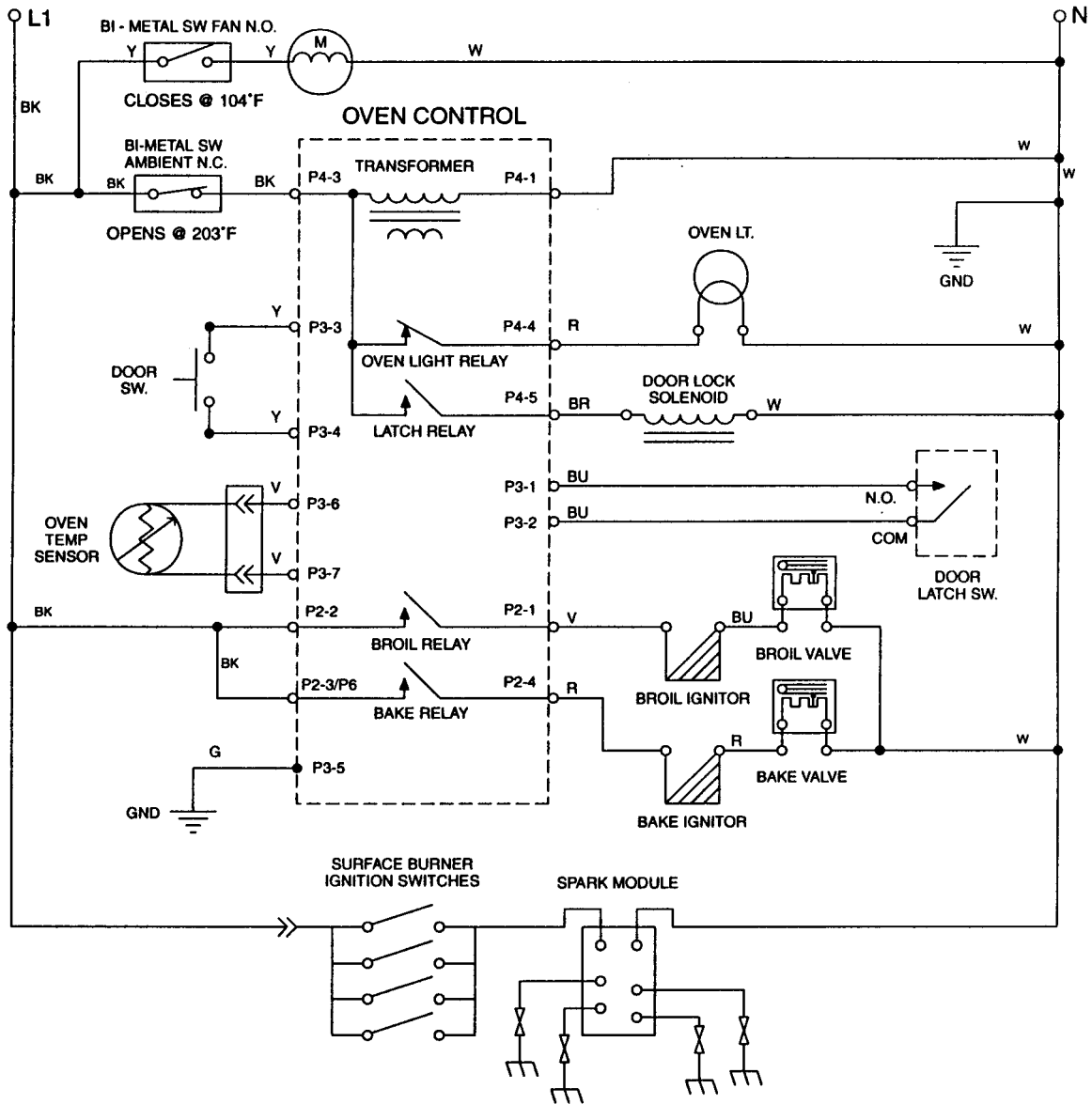

NOTE: Drawing shows door latch switch in COOK position with oven door OPEN and oven OFF.

— NOTES —

PRACTICE EXERCISE 4 ANSWERS TRACING CIRCUITS

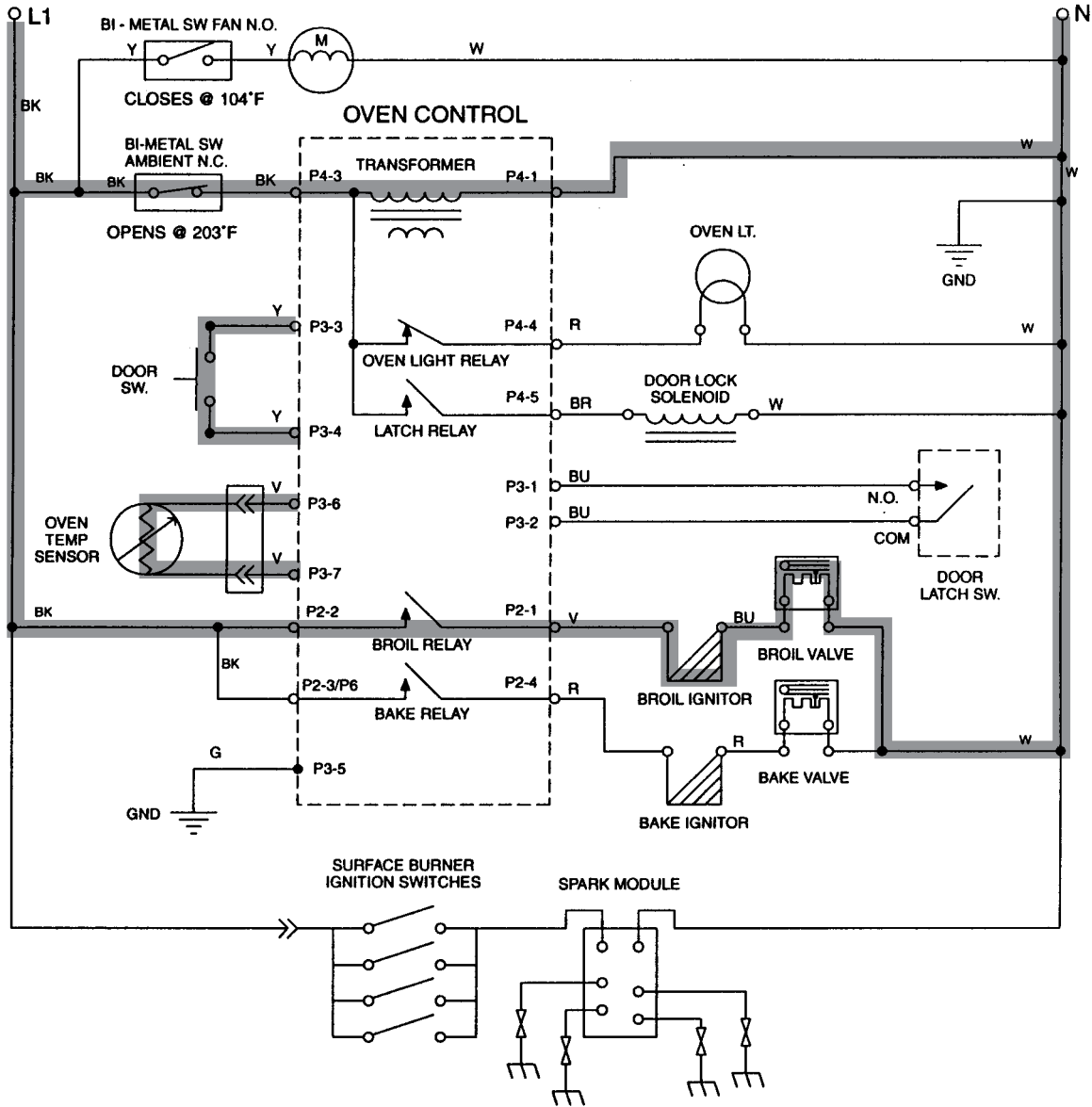

**IF GIVEN ANSWERS AND YOURS ARE DIFFERENT,
PLEASE REVIEW THE APPROPRIATE SECTION.**

120 & 240 VOLT CIRCUITS

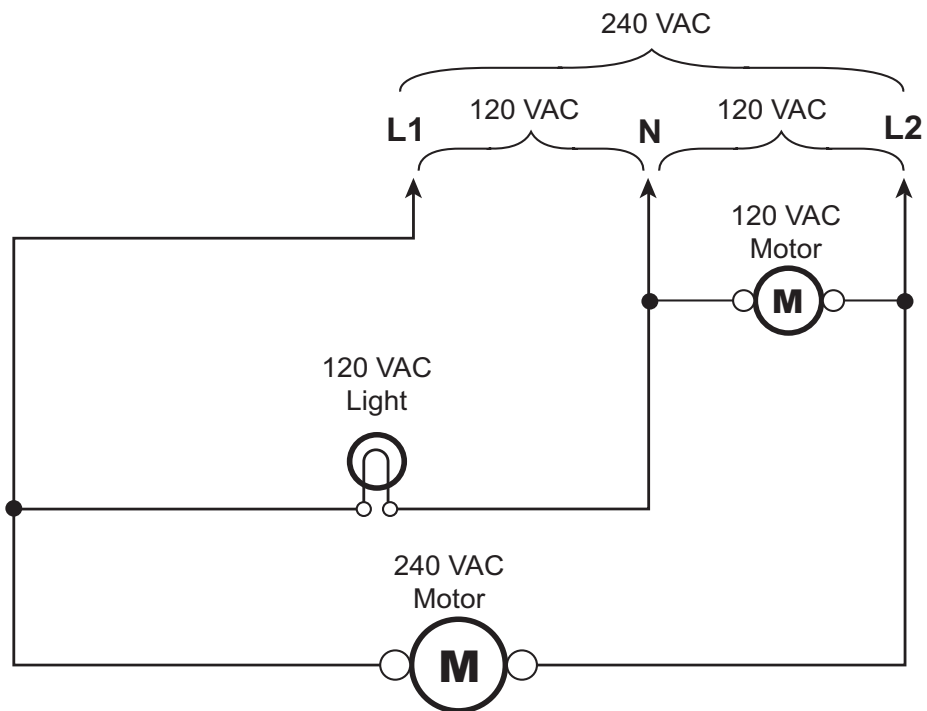
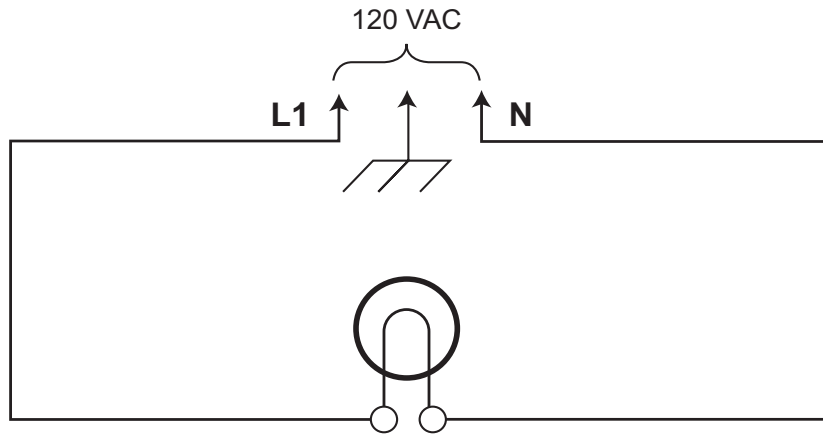

PRACTICE EXERCISE 5 TRACING CIRCUITS

Using a marking pen, close the proper switch contact, and trace the circuit that shows a surface indicator light ON.

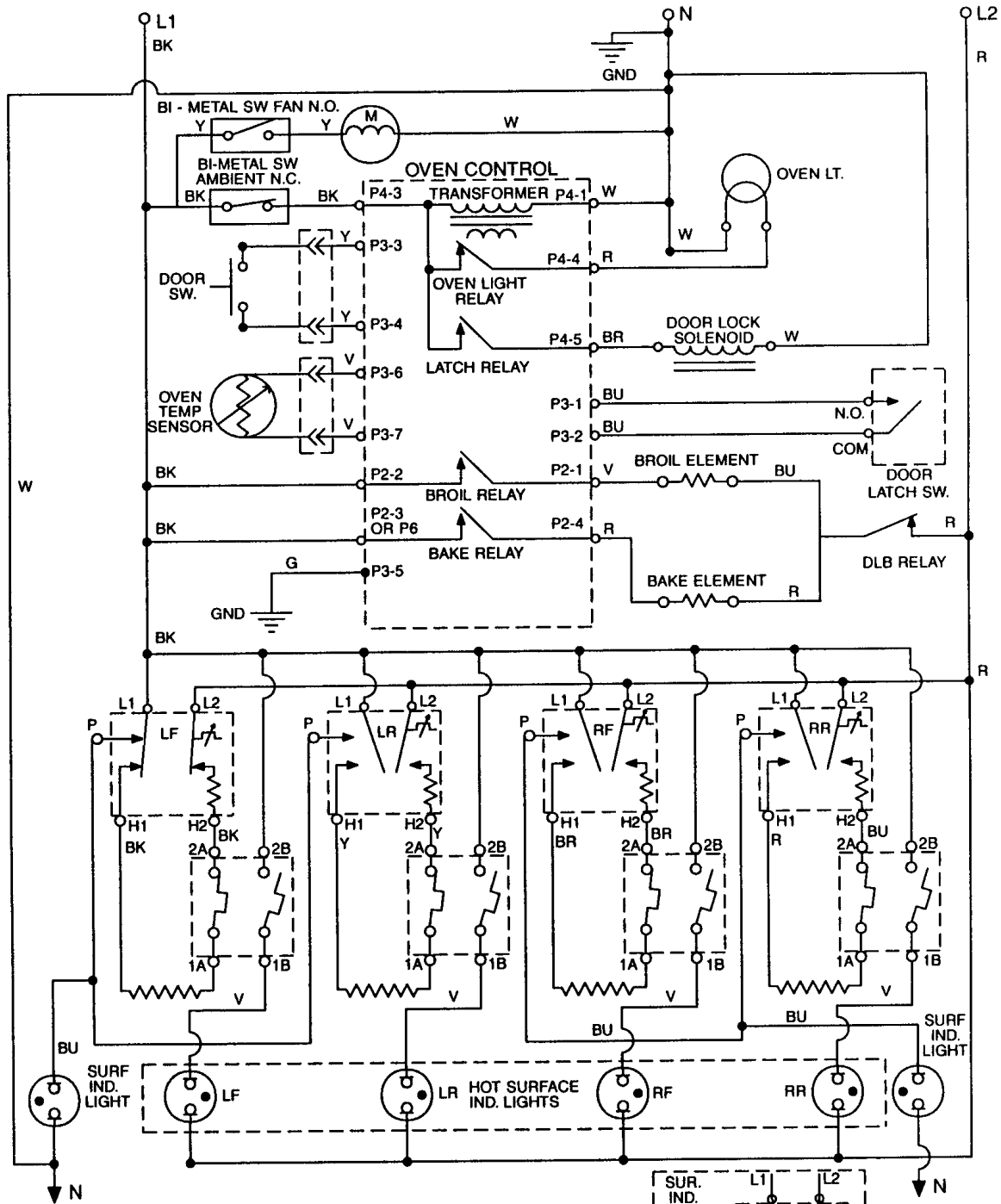

NOTES:

1. Drawing shows door latch switch in COOK position with oven door OPEN and elements OFF.
2. Diagram shows ceran models.

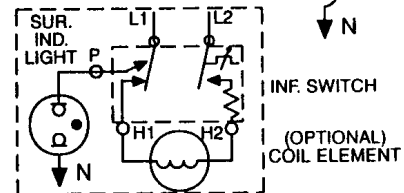

— NOTES —

PRACTICE EXERCISE 5 ANSWERS TRACING CIRCUITS

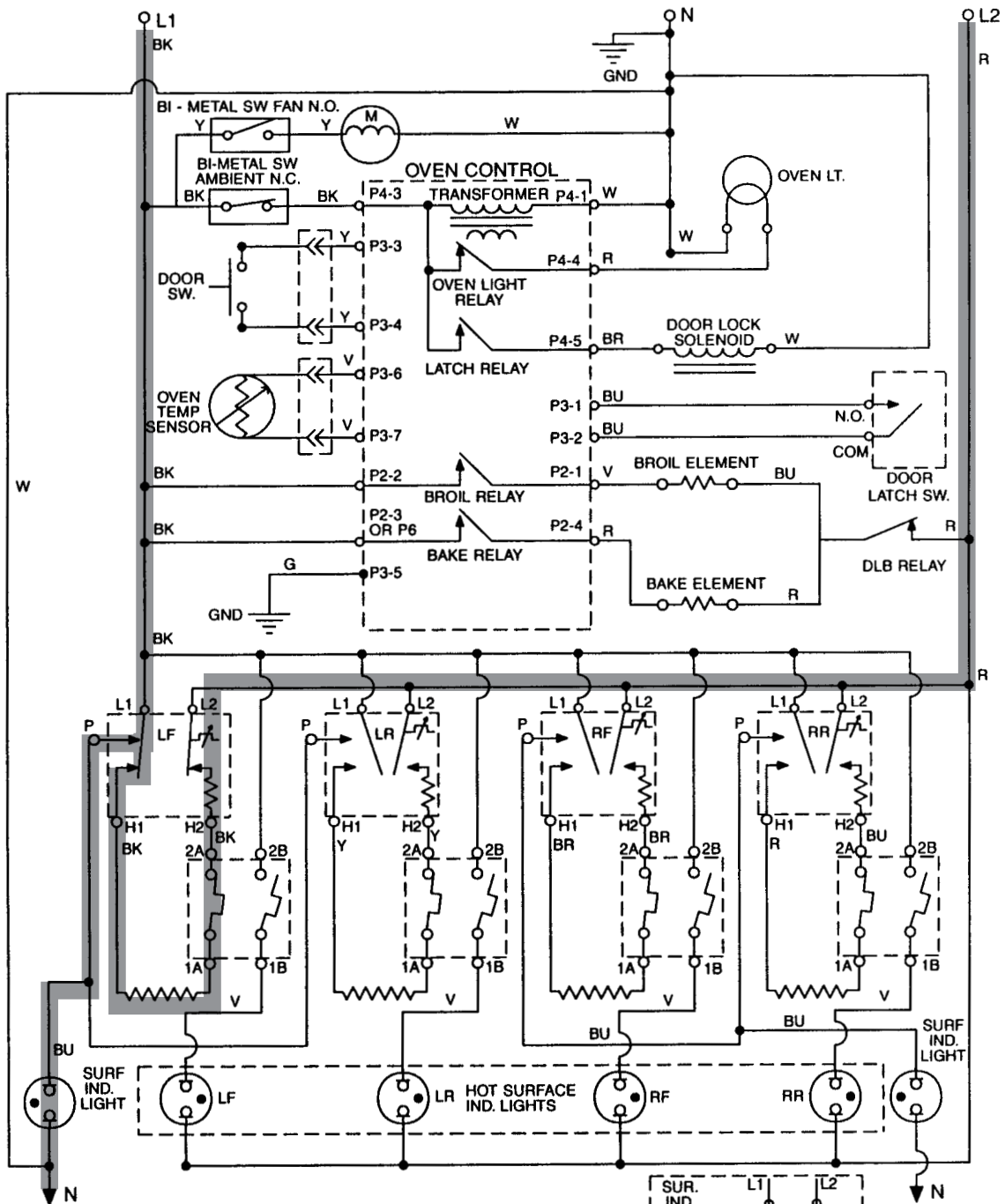

NOTES:

1. Drawing shows door latch switch in COOK position with oven door OPEN and elements OFF.
2. Diagram shows ceran models.

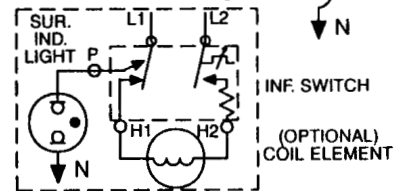

**IF GIVEN ANSWERS AND YOURS ARE DIFFERENT,
PLEASE REVIEW THE APPROPRIATE SECTION.**

USING STRIP CIRCUITS

Strip circuits are easy-to-use diagnostic tools. They are simply an abbreviated, easy-to-follow version of a complete and standard wiring diagram.

A standard wiring diagram shows so many components that it is time consuming trying to find the components involved in an active circuit. The strip circuits below show only the components involved in an active Broil and Bake circuit.

It is much faster and easier for the human eye and mind to process a strip circuit that reads from left to right, than to hunt and decipher the symbols in a standard wiring circuit. You can begin to see how much diagnosis time can be saved by using a strip circuit. By creating strip circuits from standard wiring diagrams, Whirlpool has provided you with effective tools to use in your diagnosis.

BROIL CIRCUIT

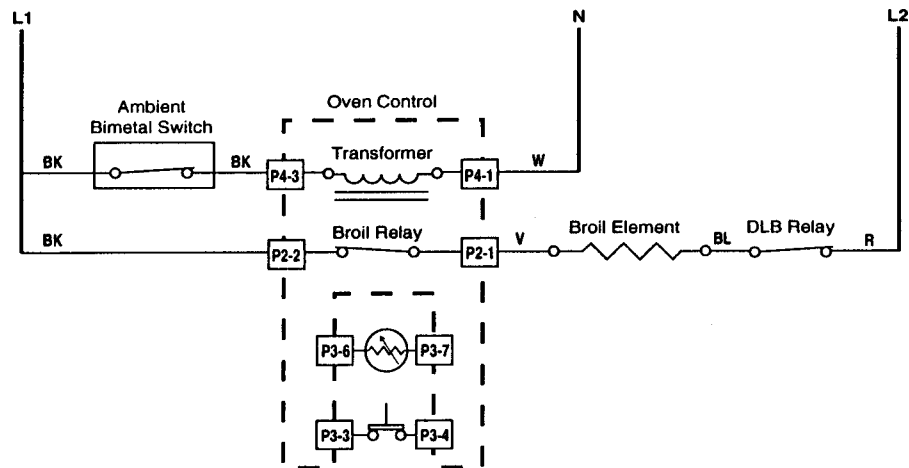

BAKE CIRCUIT

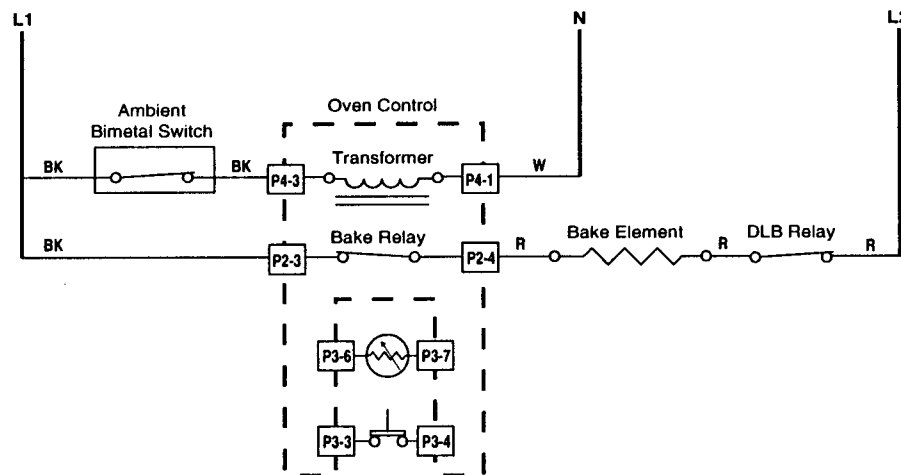

PRACTICE EXERCISE 6 STRIP CIRCUITS

Draw a strip circuit.

On the following page, fill in the missing wire colors, component names, contact points, and the L1, L2, and N lines.

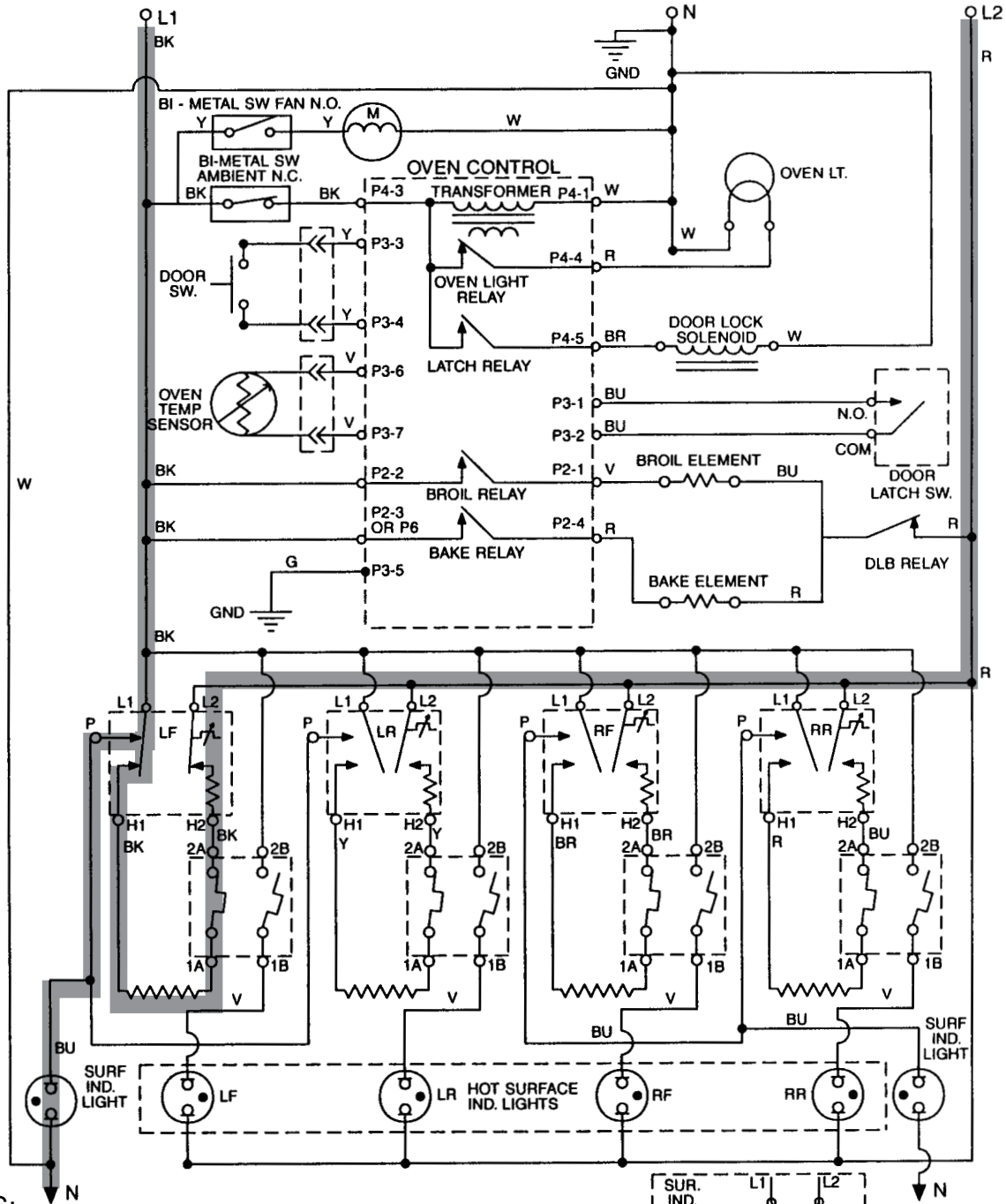

NOTES:

1. Drawing shows door latch switch in COOK position with oven door OPEN and elements OFF.
2. Diagram shows ceran models.

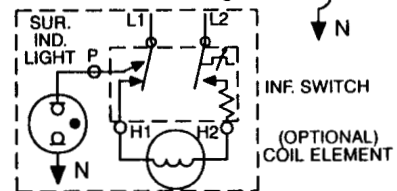

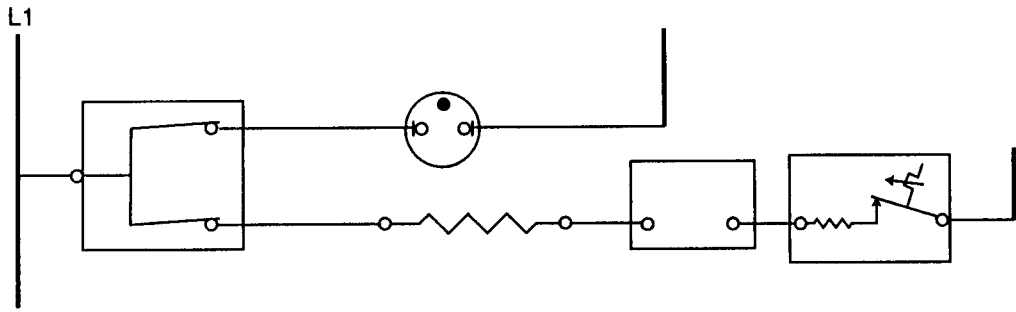

PRACTICE EXERCISE 6 ANSWERS STRIP CIRCUITS

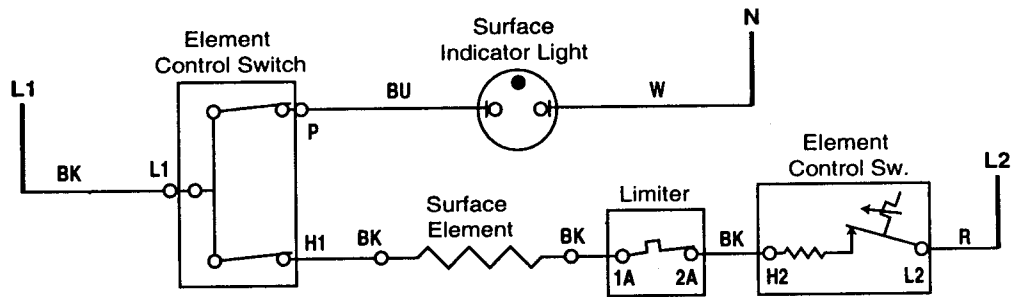

***IF GIVEN ANSWERS AND YOURS ARE DIFFERENT,
PLEASE REVIEW THE APPROPRIATE SECTION.***

CLOSING SWITCHES

SAMPLE TIMER SEQUENCE CHART (ESTERLINE)

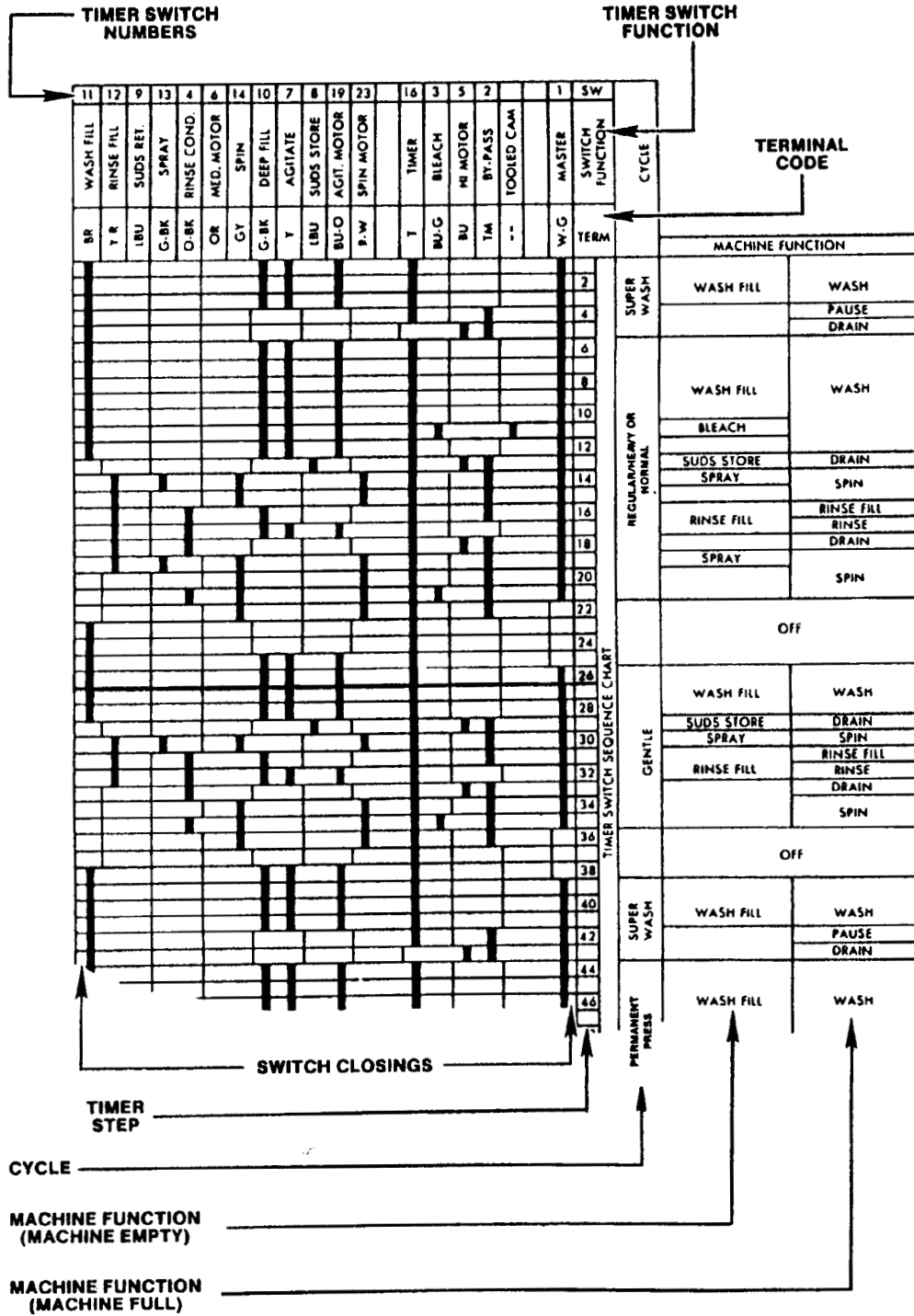

— NOTES —

PRACTICE EXERCISE 7 CLOSING SWITCHES

Locate *increment #15* on the Esterline Chart below.

Using a marking pen, close all of the switches, then trace the active circuit on the Wiring Diagram on page 2-33.

(Cycle = Pots & Pans / Heat Dry)

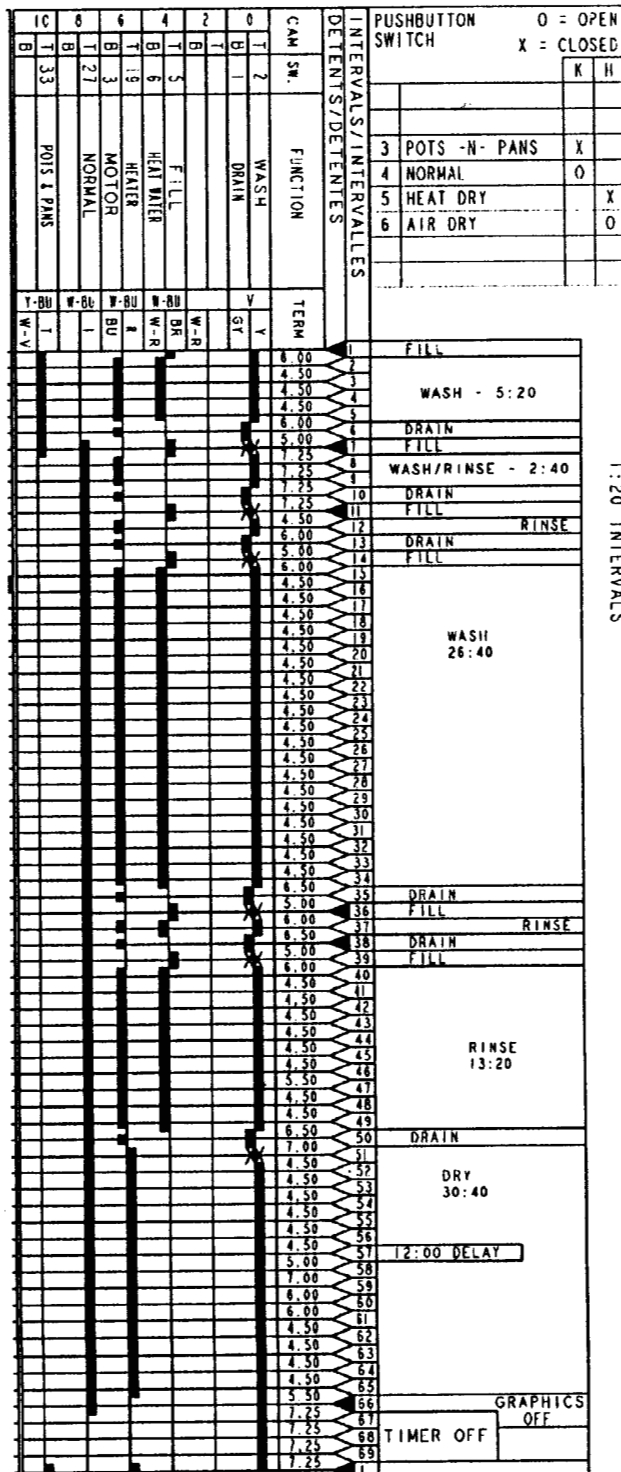

1:20 INTERVALS

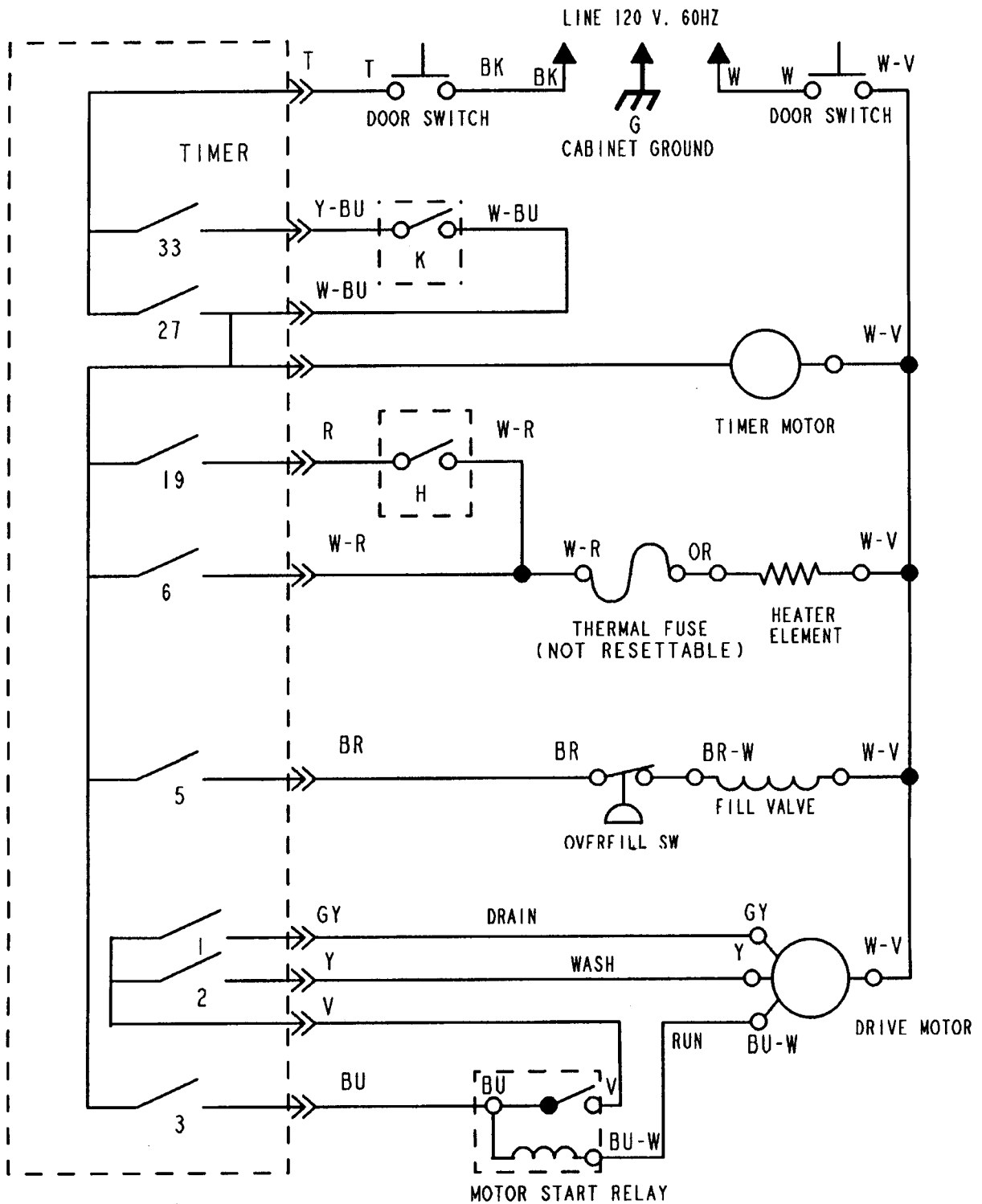

PRACTICE EXERCISE 7 ANSWERS CLOSING SWITCHES

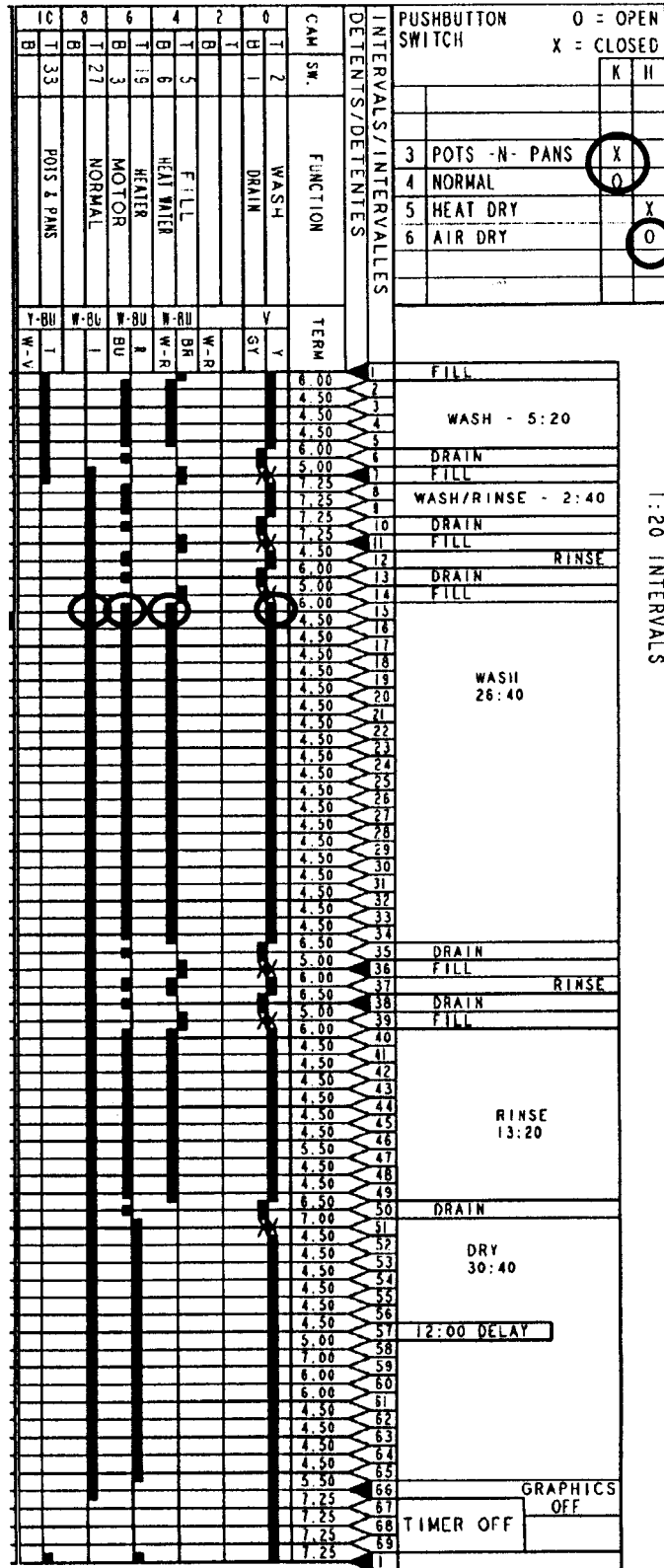

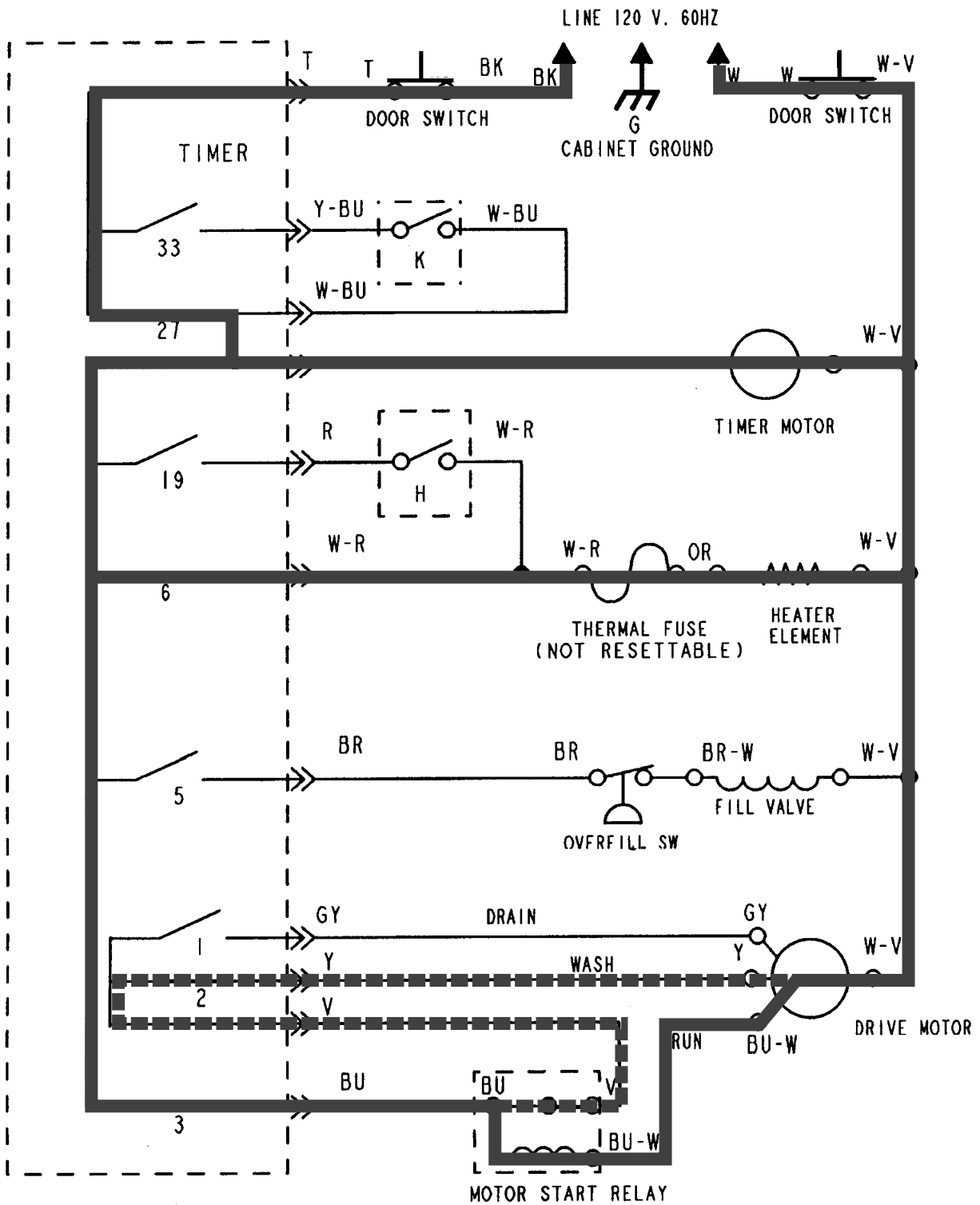

**IF GIVEN ANSWERS AND YOURS ARE DIFFERENT,
PLEASE REVIEW THE APPROPRIATE SECTION.**

GAS RANGE WIRING DIAGRAM

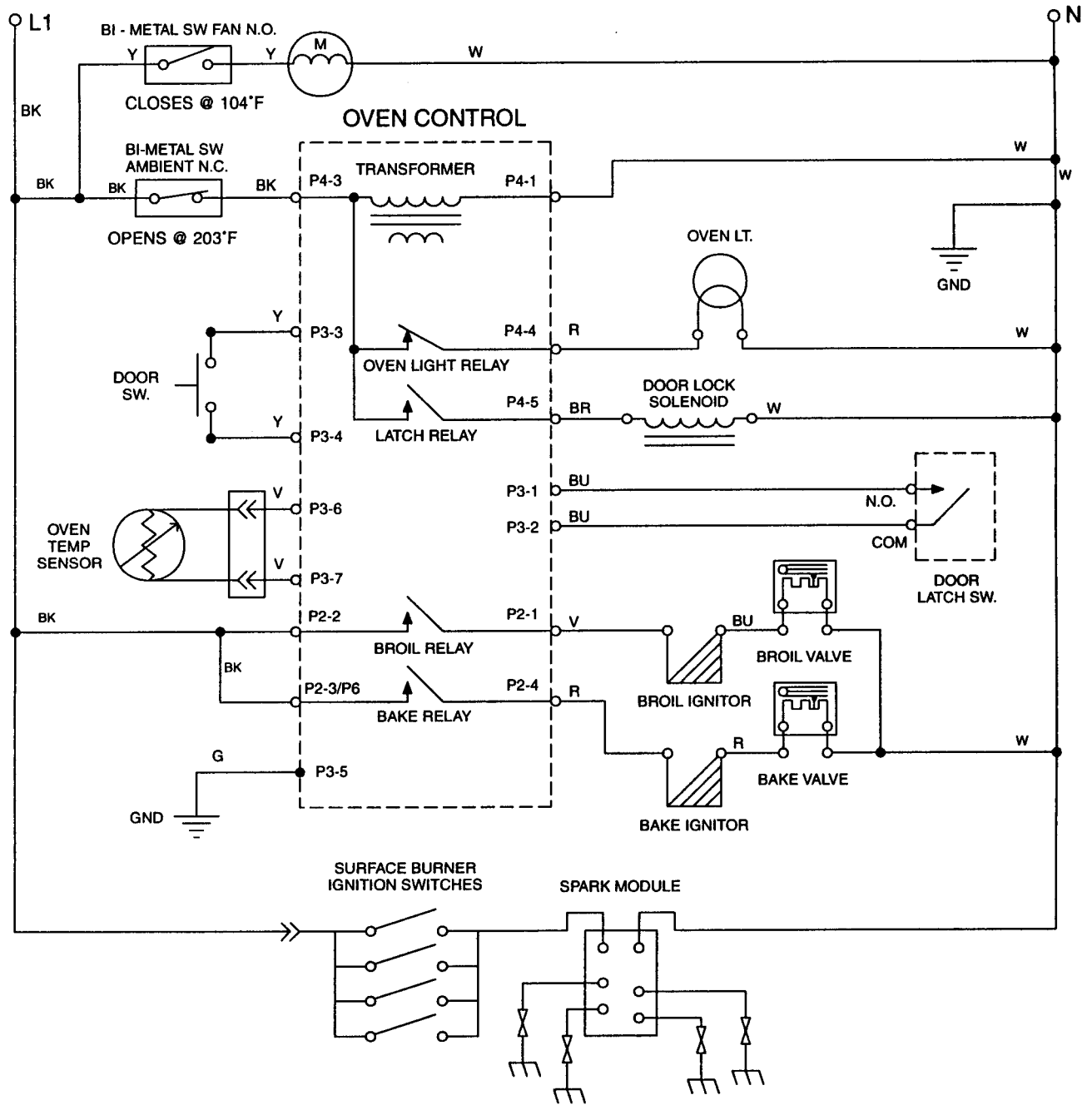

NOTE: Drawing shows oven door latch switch in COOK position with oven door OPEN, oven OFF, and light ON.

ELECTRIC BUILT-IN RANGE WIRING DIAGRAM

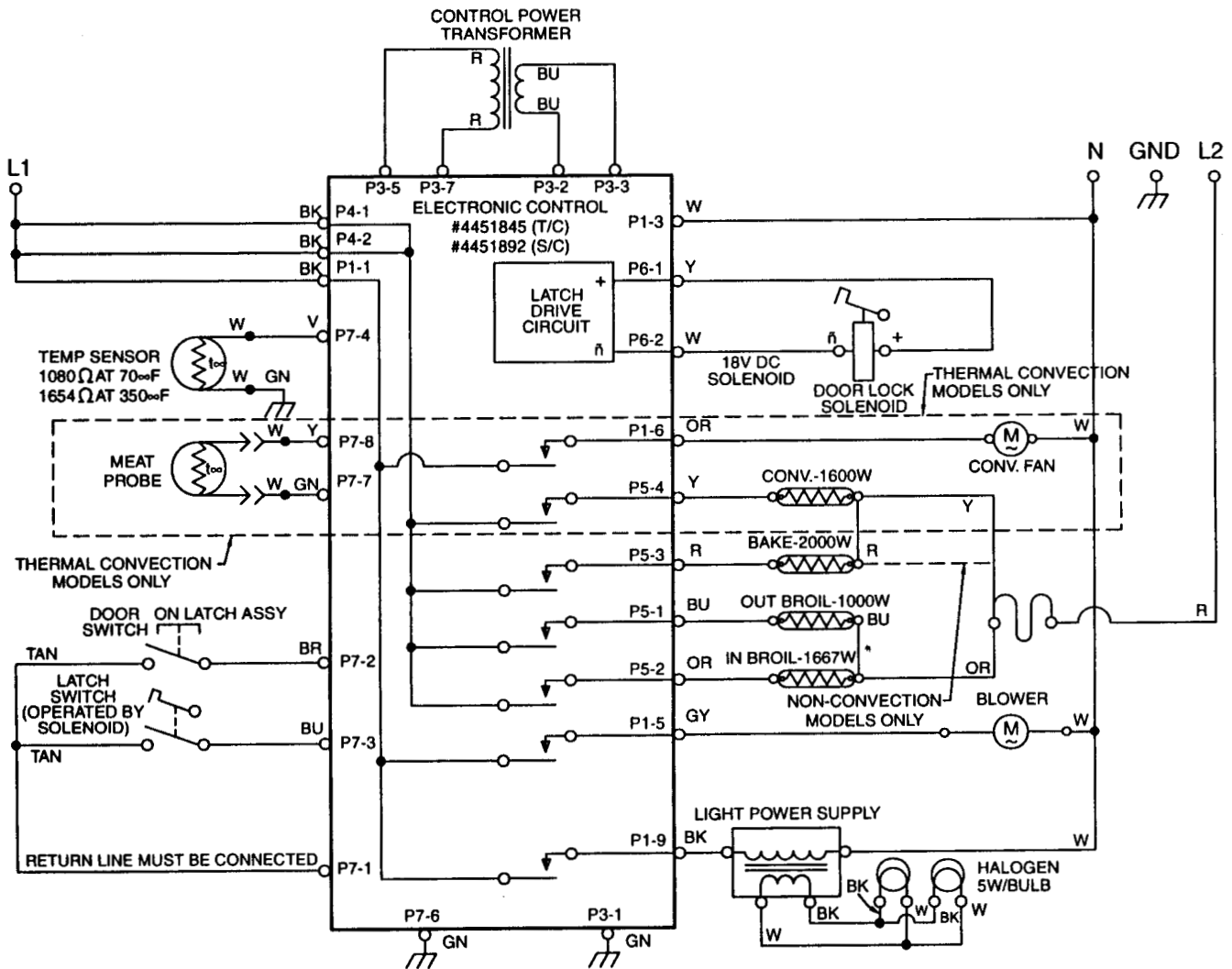
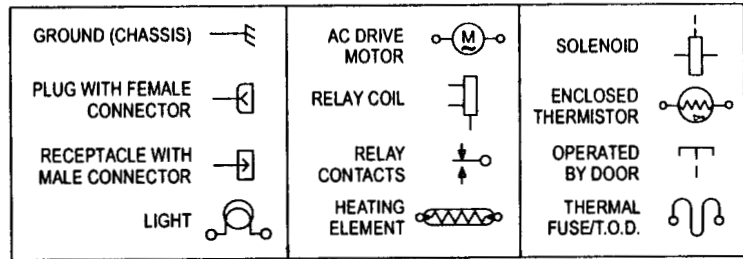

NOTES:

1. Dots indicate connections or splices.
2. Circuit shown in STANDBY/OFF mode with oven door CLOSED.

ELECTRIC BUILT-IN RANGE RELAY LOGIC CHART

RELAY LOGIC KEY

- O - OFF
- X - ON
- + - CYCLING (MAX PERIOD = 60 SEC)
- ⊗ - ON OR OFF

RELAY LOGIC CHART

MODES	RELAYS	BAKE	IN BR	OUT BR	** CONV ELEM	** CONV FAN	OV LT	BLOWER
OFF	O	O	O	O	O	⊗	⊗	
■ PREHEAT-BAKE	+	+	+	O	O	⊗	X	
BAKE 24',30'	■	+	+	+	O	O	⊗	X
BAKE 27'	■	+	+	+	O	O	⊗	X
ECONO BROIL	O	X	O	O	O	⊗	X	
MAXI BROIL	O	X	X	O	O	⊗	X	
CONV BROIL	O	X	X	O	X	⊗	X	
● PREHEAT-CONV	+	+	+	O	X	⊗	X	
CONV ROAST 24' ●	X	O	X	O	X	⊗	X	
→ CONV ROAST 27',30' ●	X	+	X	O	X	⊗	X	
CONV BAKE 24' ●	O	O	O	+	X	⊗	X	
CONV BAKE 27' ●	O	O	O	X	X	⊗	X	
CONV BAKE 30' ●	+	O	O	X	X	⊗	X	
▲ PREHEAT-CLEAN	+	+	+	O	O	O	X	
CLEAN ▲	X	+	+	O	O	O	X	
PREHEAT DEHYDRATE	O	O	O	+	X	⊗	X	
DEHYDRATE	O	O	O	X	X	⊗	X	
PREHEAT-BREAD	O	O	O	+	X	⊗	X	
RAISING BREAD	O	O	O	+	X	⊗	X	

SELF-CLEANING GAS RANGE WIRING DIAGRAM

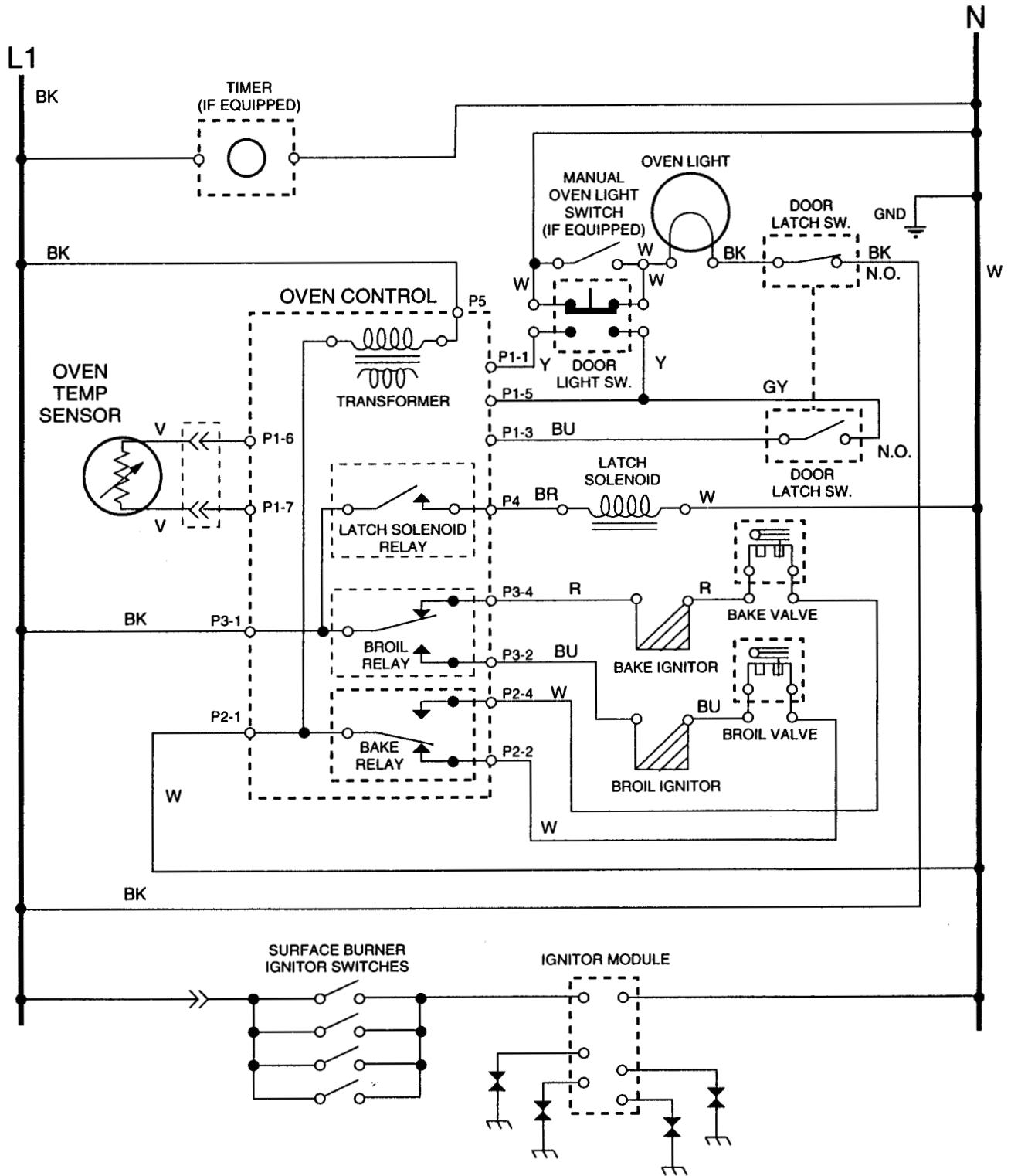

NOTE: Drawing shows oven door latch switch in COOK position with oven door OPEN, oven OFF, and light ON.

DUET DRYER WIRING DIAGRAM

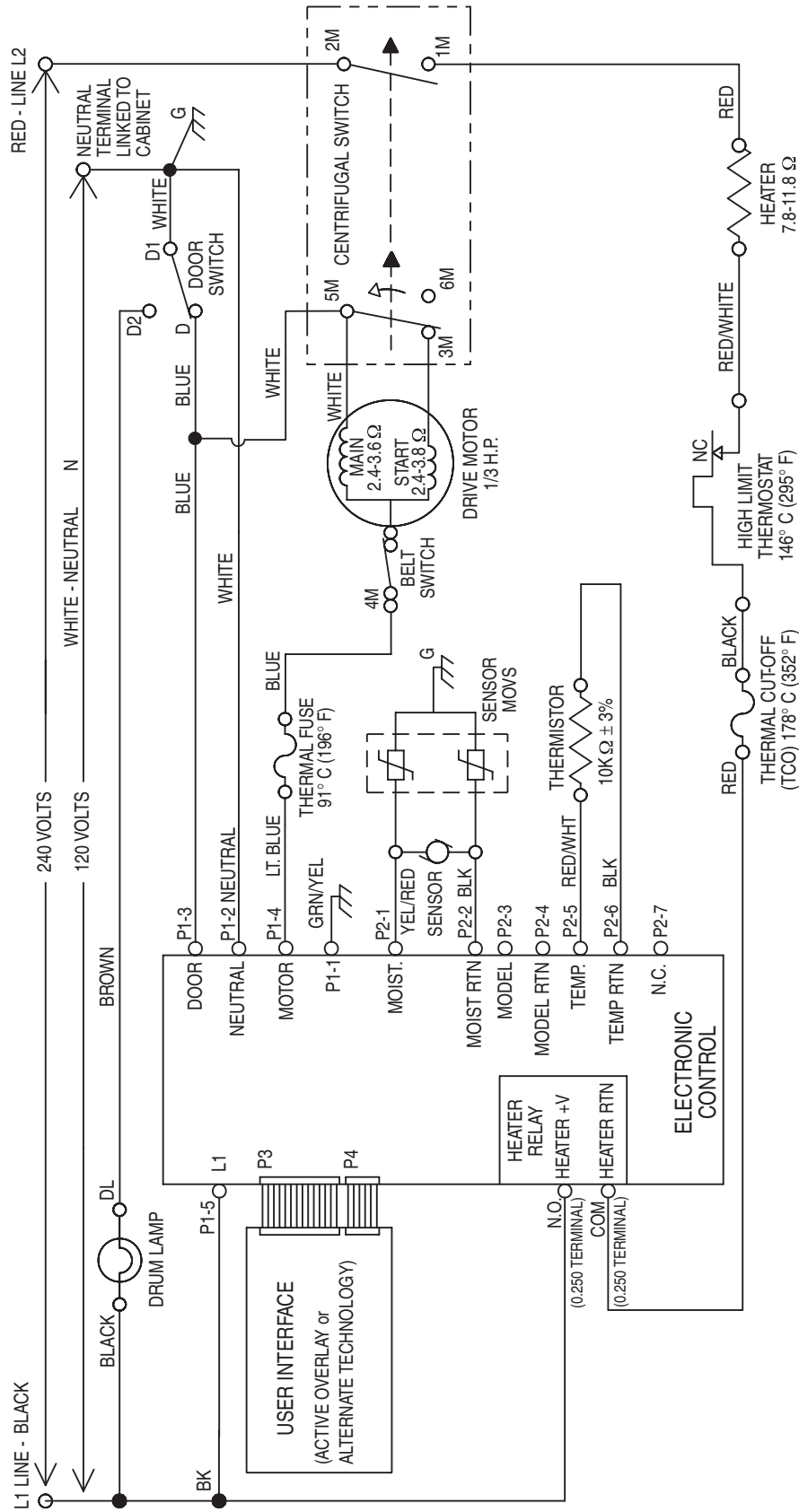

DUET WASHER WIRING DIAGRAM

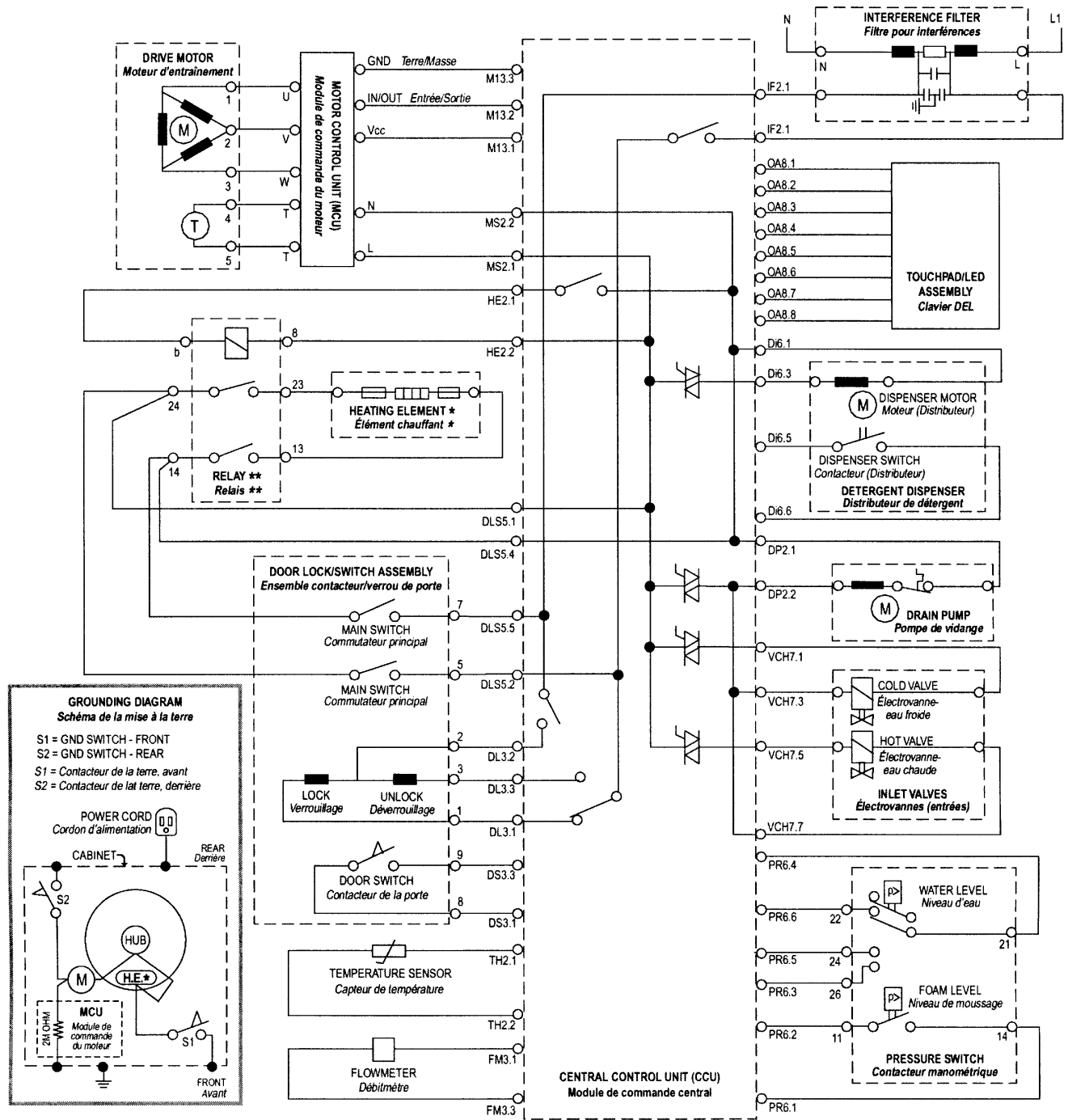

* HEATING ELEMENT NOT PRESENT ON ALL MODELS.
* L'élément chauffant n'est pas présent dans tous les modèles.

** RELAY NOT PRESENT ON ALL MODELS.
** Le relais n'est pas présent dans tous les modèles.

CALYPSO WASHER WIRING DIAGRAM

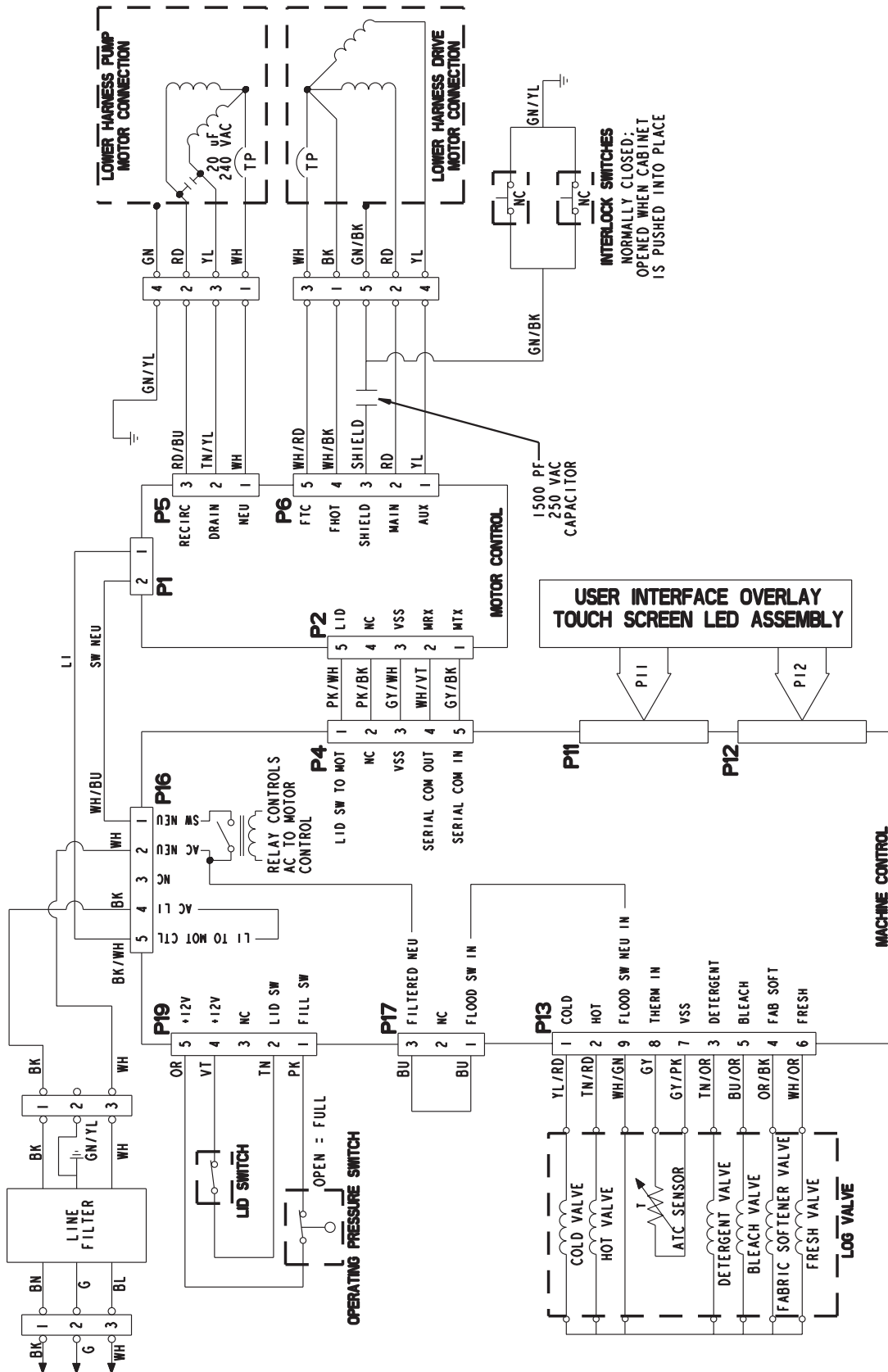

DISHWASHER WIRING DIAGRAM

SCHEMATIC SHOWN WITH DOOR SWITCH & ALL OTHER NORMALLY OPEN CONTACTS OPEN.

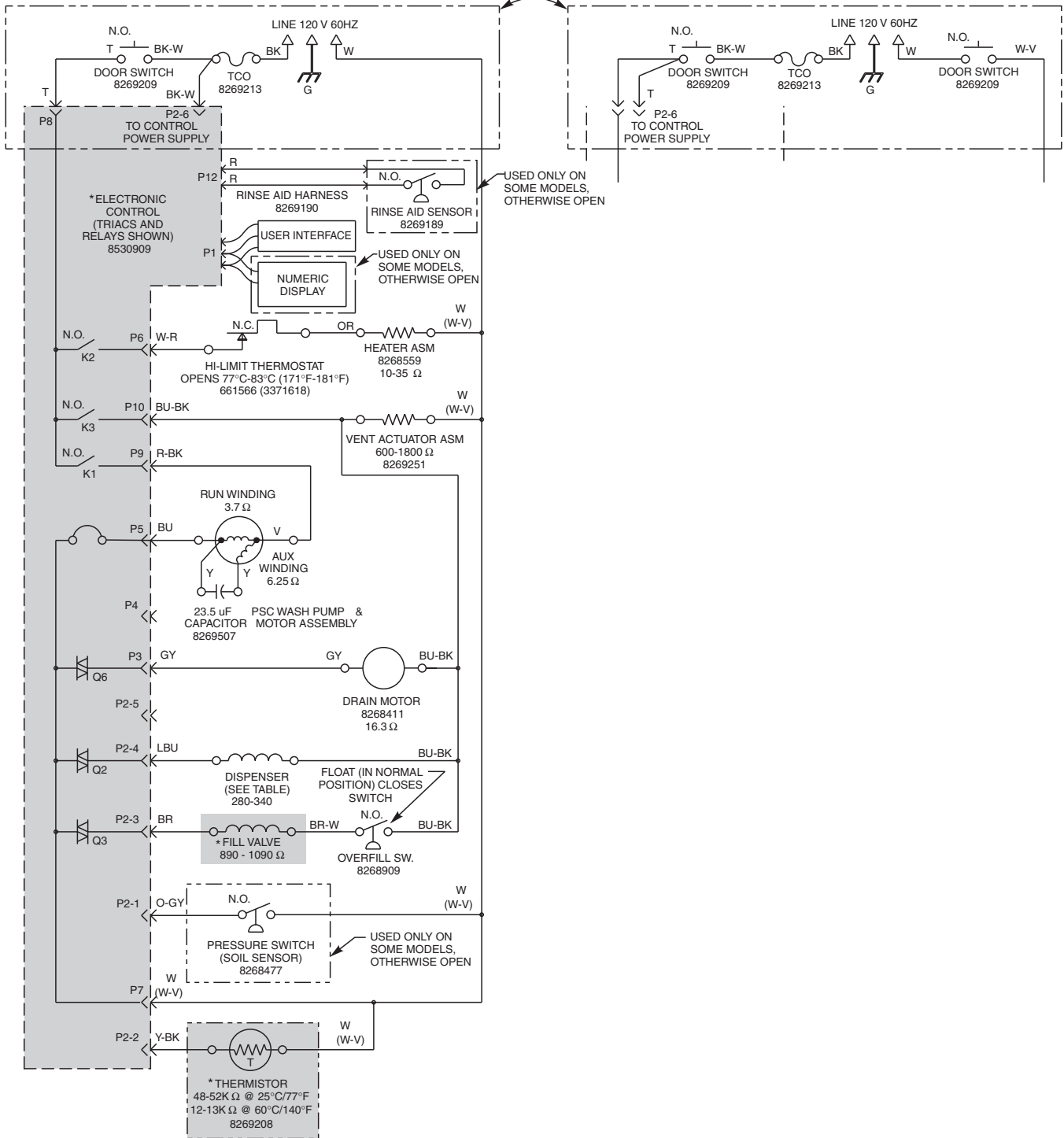

* DENOTES ENERGY EFFICIENT COMPONENTS.
DO NOT SUBSTITUTE.

— NOTES —

PRODUCT SPECIFICATIONS AND WARRANTY INFORMATION SOURCES

IN THE UNITED STATES:

FOR PRODUCT SPECIFICATIONS AND WARRANTY INFORMATION CALL:

FOR WHIRLPOOL PRODUCTS: 1-800-253-1301
FOR KITCHENAID PRODUCTS: 1-800-422-1230
FOR ROPER PRODUCTS: 1-800-447-6737

FOR TECHNICAL ASSISTANCE WHILE AT THE CUSTOMER'S HOME CALL:

THE TECHNICAL ASSISTANCE LINE: 1-800-253-2870

**HAVE YOUR STORE NUMBER READY TO IDENTIFY YOU AS AN
AUTHORIZED SERVICER**

FOR LITERATURE ORDERS:

PHONE: 1-800-851-4605

FOR TECHNICAL INFORMATION AND SERVICE POINTERS:

www.servicematters.com

IN CANADA:

FOR PRODUCT SPECIFICATIONS AND WARRANTY INFORMATION CALL:

1-800-461-5681

FOR TECHNICAL ASSISTANCE WHILE AT THE CUSTOMER'S HOME CALL:

THE TECHNICAL ASSISTANCE LINE: 1-800-488-4791

**HAVE YOUR STORE NUMBER READY TO IDENTIFY YOU AS AN
AUTHORIZED SERVICER**

