

# ***Thermador***<sup>®</sup>

THE SCIENCE OF COOKING.<sup>™</sup>

## **UNIVERSAL COOK'N'VENT DOWNDRAFT SYSTEM**

MODELS: CVS30R, CVS36R, & CVS45R

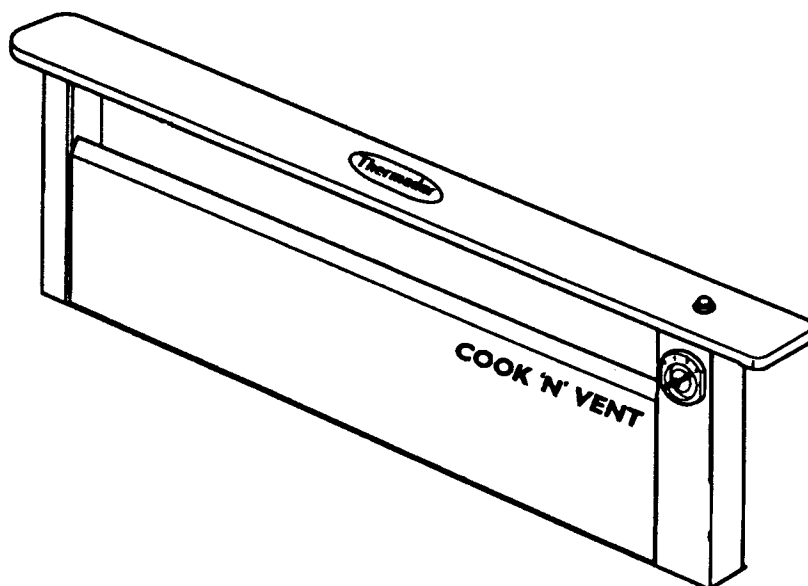

# **SERVICE MANUAL**

***Thermador***<sup>®</sup>

A MASCO COMPANY

5551 MCFADDEN • HUNTINGTON BEACH, CALIFORNIA 92649 • TELEPHONE: 1(800) 735-4328

Lit. No. 94-22-005

September, 1997

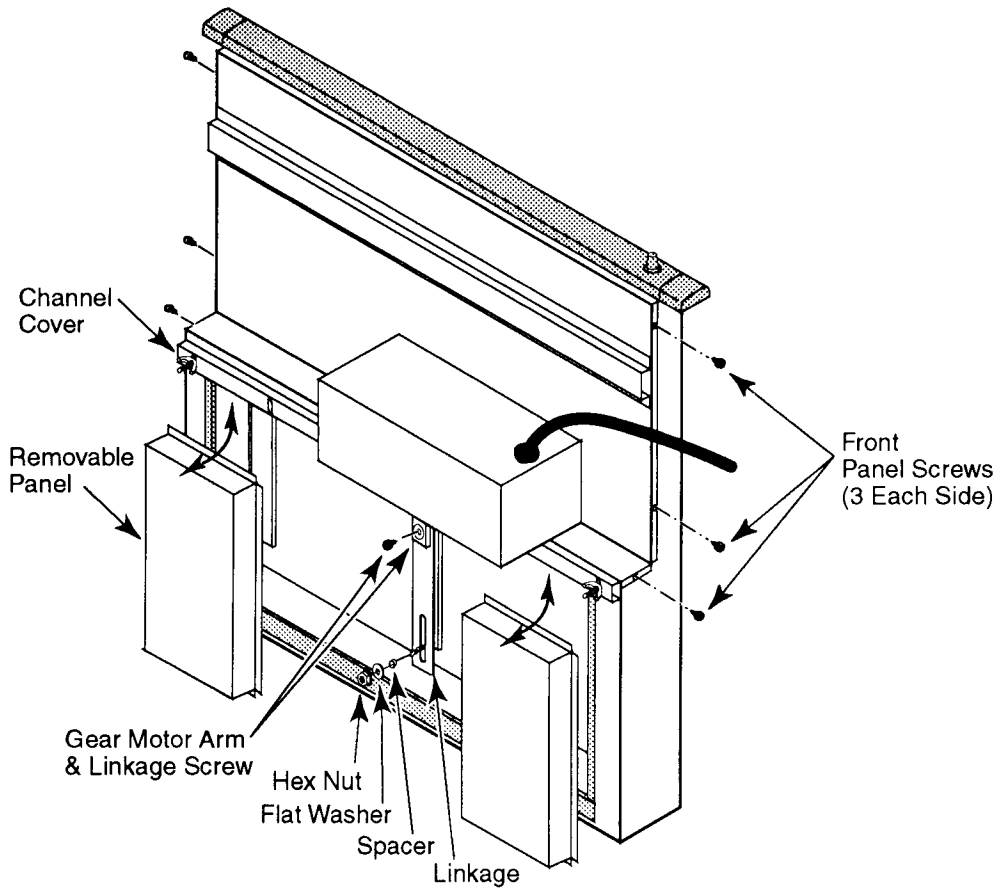

To Remove Top Cap, & Control Components Refer To Pages 2-2 & 2-3.

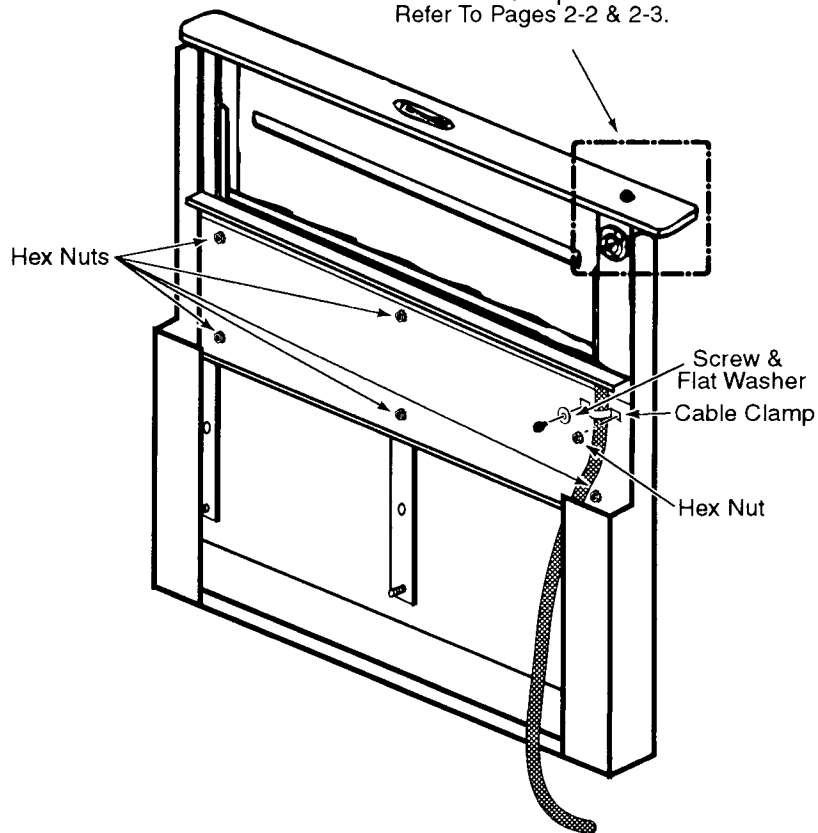

THIS MANUAL CONTAINS INFORMATION THAT IS NECESSARY FOR SERVICING THE THERMADOR® 30" 36" & 45" UNIVERSAL COOK'N'VENT DOWNDRAFT SYSTEMS,

MODELS: *CVS30R, CVS36R, & CVS45R*

**THIS MANUAL IS DESIGNED TO BE USED ONLY BY QUALIFIED SERVICE PERSONNEL. THERMADOR RECOMMENDS THAT CUSTOMERS DO NOT SERVICE THEIR OWN UNITS, DUE TO THE COMPLEXITY AND THE RISK OF HIGH-VOLTAGE ELECTRICAL SHOCK.**

THE INFORMATION IS ORGANIZED TO HELP THE SERVICER EASILY FIND WHAT IS NEEDED TO REPAIR THE UNIT.

# Table Of Contents

|  | <b>Page</b> |
|--|-------------|
| General .....  | 1-1         |
| Serial Number/Data Sticker & Wiring Diagram Locations .....                      | 1-1         |
| Symbols You Will See In The Manual .....   | 1-2         |
| Important Safety Information .....   | 1-2         |
| Thermador Cook'n'Vent Warranty .....   | 1-3         |
| Servicing The Components .....   | 2-1         |
| Cook'n'Vent Component Locations .....  | 2-1         |
| Removing The Top Cap, And The Up/Down & Speed Control Switches .....             | 2-2         |
| Removing The Power Cord, The Gear Motor,<br>And Gear Motor & Vent Switches ..... | 2-4         |
| Removing The Snorkel Assembly .....  | 2-6         |
| Troubleshooting .....  | 3-1         |
| Chart .....  | 3-1         |
| Wiring Diagram .....   | 3-3         |
| Strip Circuits .....   | 3-4         |

— NOTES —

# GENERAL

## SERIAL NUMBER/DATA STICKER & WIRING DIAGRAM LOCATIONS

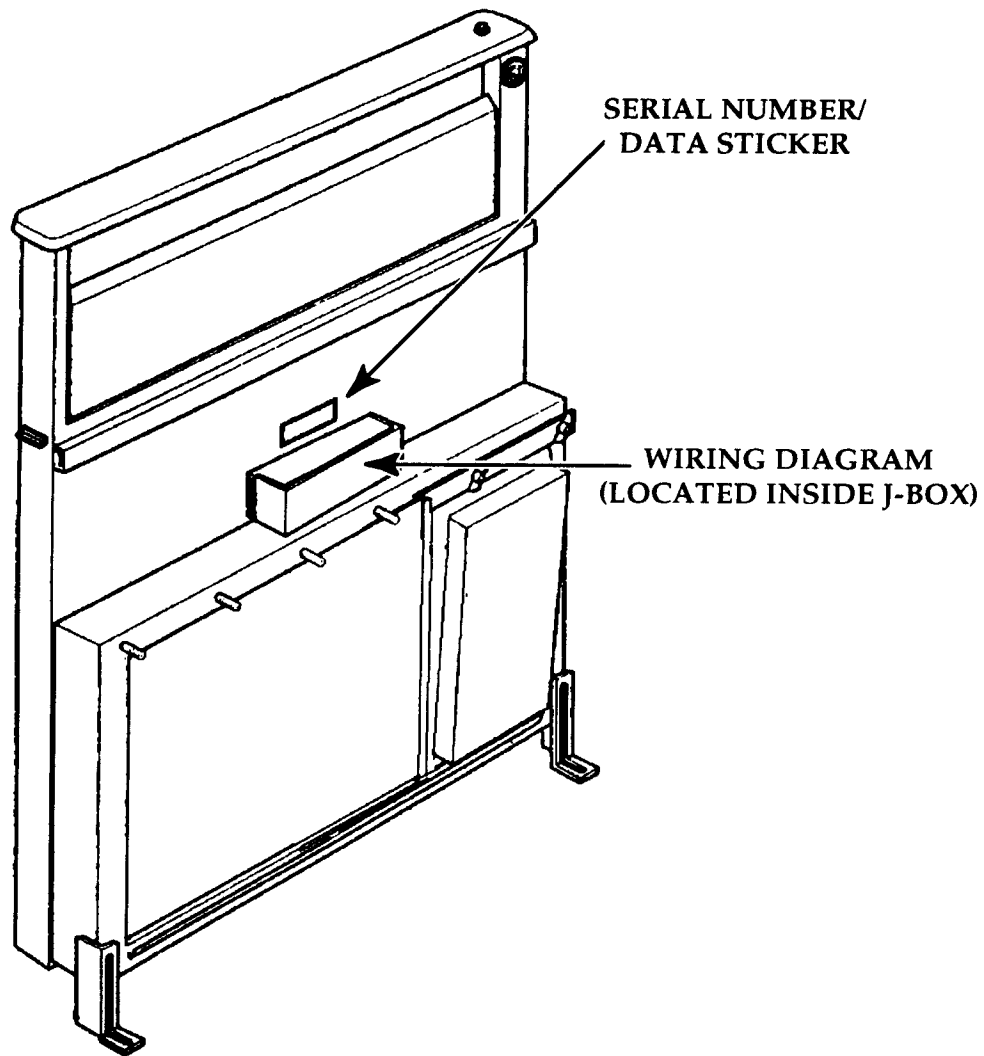

## SYMBOLS YOU WILL SEE IN THE MANUAL

The following symbols are provided throughout this manual. For reasons of personal safety and

proper operation and servicing of the vent, follow the instructions carefully each time you see one of the symbols.

### **WARNING**

This symbol alerts you to such dangers as personal injury, burns, fire, and electrical shock.

### **CAUTION**

This symbol alerts you to actions that could cause product damage (scratches, dents, etc.), and damage to personal property.

## IMPORTANT SAFETY INFORMATION

### **WARNING**

To reduce the risk of fire, electric shock, or injury to persons, observe the following:

- Use the vent only in the manner intended by the manufacturer.
- Before servicing or cleaning the vent, switch the power off at the service panel, and lock it to prevent power from being switched on accidentally.

### **CAUTION**

Do not use the vent to exhaust hazardous or explosive materials and vapors.

THERMADOR ASSUMES NO RESPONSIBILITY FOR ANY REPAIRS MADE ON OUR PRODUCTS BY ANYONE OTHER THAN AUTHORIZED THERMADOR SERVICE TECHNICIANS.

# THERMADOR® COOK'N'VENT WARRANTY

| Length of Warranty  | Thermador will pay for:  | Thermador will not pay for:  |
|---|--|--|
| <p><b>FULL ONE YEAR WARRANTY</b></p> <p>For one year from date of installation or date of occupancy for a new previously unoccupied dwelling, any part which fails in normal home use will be repaired or replaced free of charge.</p> <p>Save all dated receipts or other evidence of date of installation/occupancy date.</p> | <p>All repair labor and replacement parts found to be defective due to materials and workmanship. Service must be provided by a Thermador® Authorized Service Agency, during normal working hours.</p> | <ol style="list-style-type: none"> <li>1. Service by an unauthorized agency. Damage or repairs by an unauthorized agency or use of unauthorized parts.</li> <li>2. Service visits to: <ul style="list-style-type: none"> <li>• Teach you how to use the appliance.</li> <li>• Correct the installation. You are responsible for providing electrical wiring and/or gas installation and other connecting facilities.</li> <li>• Reset circuit breakers or replace home fuses.</li> </ul> </li> <li>3. Damage caused from accident, abuse, alteration, misuse, incorrect installation or installation not in accordance with local codes, or improper storage of the appliance.</li> <li>4. Repairs due to other than normal home use.</li> </ol> |

This warranty applies to appliances used in normal family households; it does not cover their use in commercial situations.

This warranty is for products purchased and retained in the 50 states of the U.S.A., the District of Columbia, and Canada. The warranty applies even if you should move during the warranty period. Should the appliance be sold by the original purchaser during the warranty period, the new owner continues to be protected until the expiration of the original purchaser's warranty period.

This warranty gives you specified legal rights. You may also have other rights which vary from state-to-state.

## HOW TO OBTAIN SERVICE

For service, contact the factory authorized agency in your area, the dealer from whom you purchased the appliance, or write us at the address shown below.

We want you to be a satisfied customer. If a situation arises that has not been resolved to your satisfaction, please let us know. Write to:

Consumer Relations Department  
5551 McFadden Avenue  
Huntington Beach, CA 92649

or phone:

(800) 735-4328

Please be sure to include the Model Number, Serial Number (located on the data sticker), and the Date of Original Purchase/Installation.



— NOTES —

# SERVICING THE COMPONENTS

The serviceable components inside the 30", 36", and 45" Universal Cook'n'Vent are included in this section of the manual. Refer to the section that

deals with the component you wish to service. The component locations are shown below.

## COOK'N'VENT COMPONENT LOCATIONS

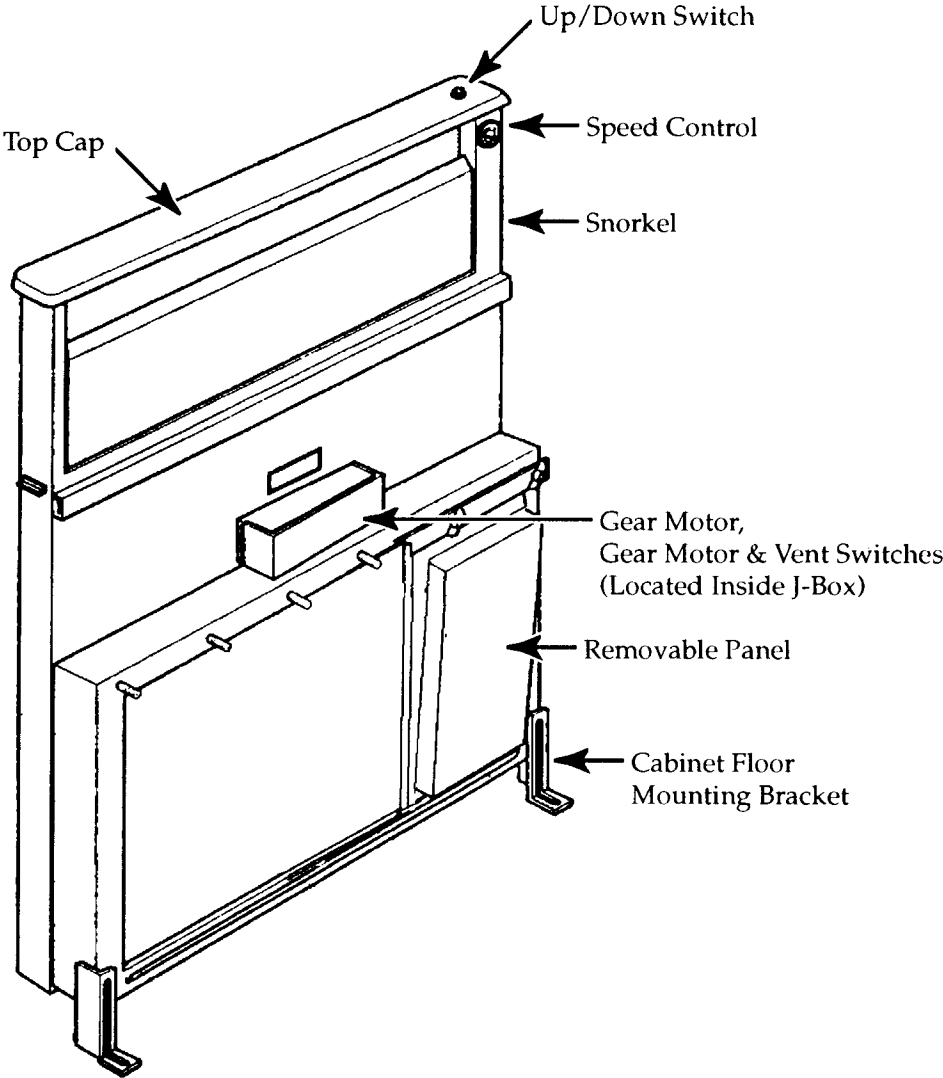

# REMOVING THE TOP CAP, AND THE UP/DOWN & SPEED CONTROL SWITCHES

## **WARNING**

Turn off the power circuit to the Cook'n'Vent at the main (house) junction box before servicing this unit.

## **CAUTION**

When you work on the Cook'n'Vent, be careful when handling the sheet metal parts. There are sharp edges present and you can cut yourself if you are not careful.

1. Raise the snorkel.
2. Turn off the electrical power going to the Cook'n'Vent.
3. Remove the front panel and two filters from the snorkel.

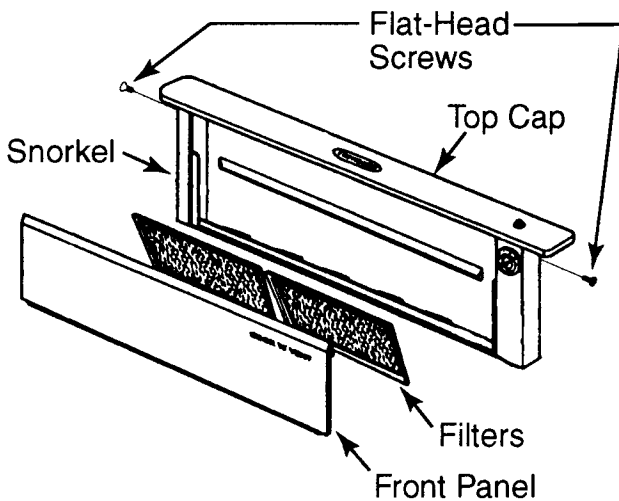

4. **To remove top cap**, remove the two flat-head screws from the ends and lift the cap off the snorkel. NOTE: If you are replacing the top cap, remove the rubber o-ring from the plastic grommet and remove the grommet from the top cap.

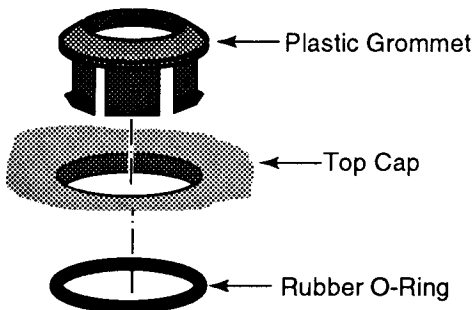

To replace the switches, refer to the illustration on the next page.

5. Remove the knob from the control shaft and unclip the bezel.
6. Remove the two bracket screws from the side of the snorkel control box.
7. Lift the mounting bracket out of the snorkel control box just far enough to access the switches and wiring connectors.
8. **To remove the up/down switch**, remove the button and round nut and disconnect the three switch wire connectors.
9. **To remove the speed control switch**, remove the two screws and four wires from the switch. To remove a wire, insert the end of a paper clip into the wire hole, then press in on the clip and pull the wire out of the hole.
10. Reassemble the snorkel.

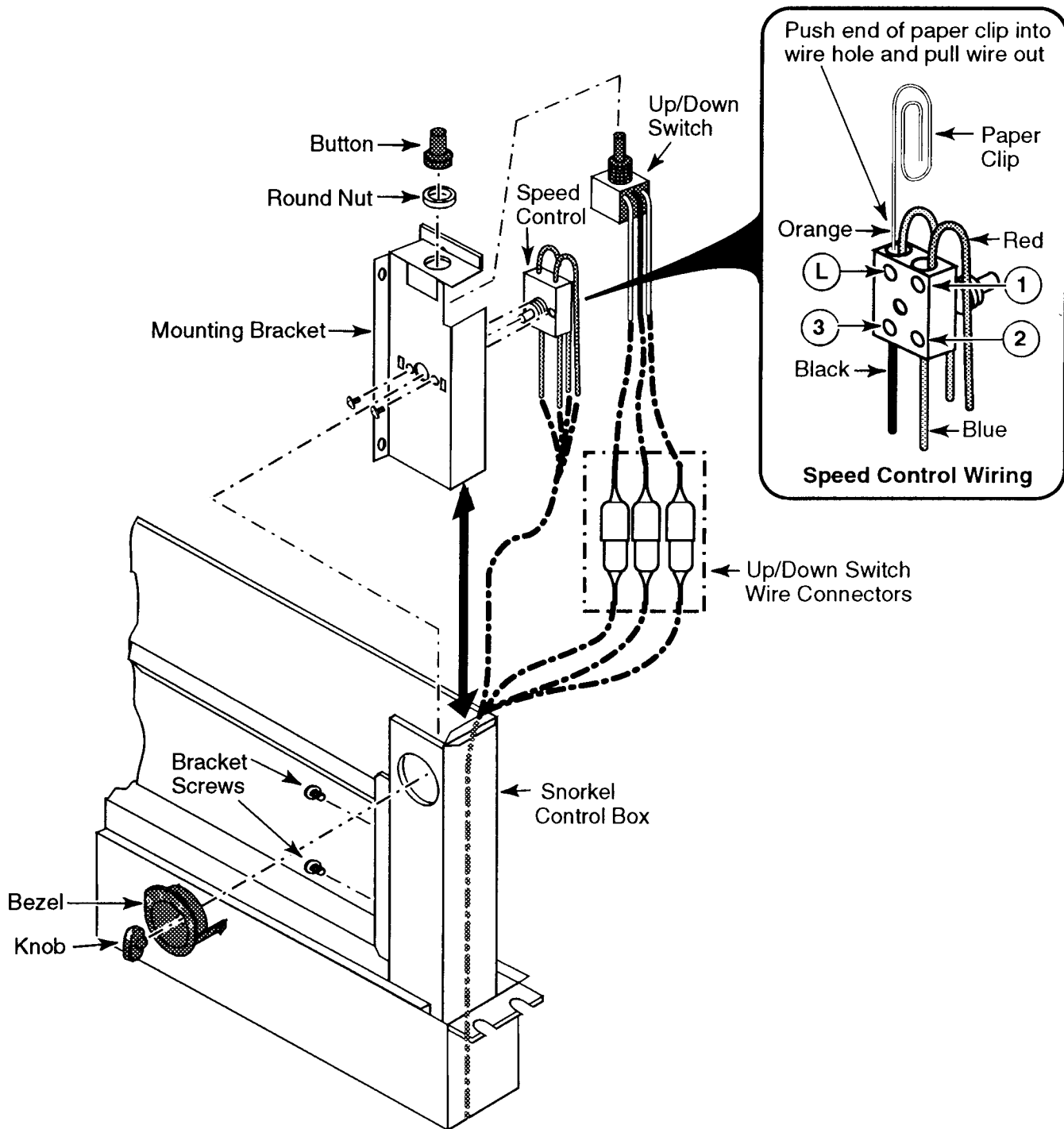

# REMOVING THE POWER CORD, THE GEAR MOTOR, AND GEAR MOTOR & VENT SWITCHES

## ⚠ WARNING

Turn off the power circuit to the Cook'n'Vent at the main (house) junction box before servicing this unit.

## ⚠ CAUTION

When you work on the Cook'n'Vent, be careful when handling the sheet metal parts. There are sharp edges present and you can cut yourself if you are not careful.

1. Raise the snorkel and remove the front panel and filters (see page 2-2), then lower the snorkel and turn off the electrical power going to the Cook'n'Vent.
2. Remove the three screws from the J-box cover and remove the cover.

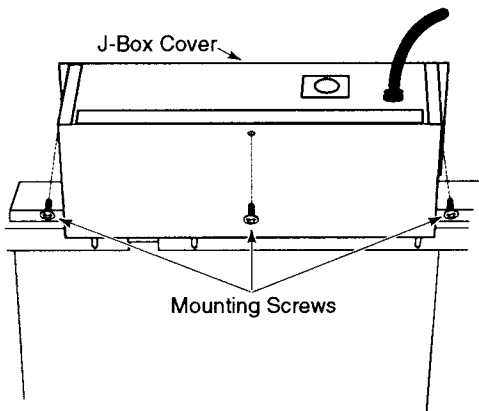

3. **To remove the power cord** (see the top illustration on the next page):
  - a) Remove the strain relief from the cord and J-box.
  - b) Loosen the terminal screws on the terminal block for the black and white power cord leads, and remove the wires.
  - c) Remove the hex-head screw from the green-yellow ground wire on the J-box.
  - d) Remove the old power cord and install the new one in its place.

**To remove the gear motor and switches**, refer to the illustrations at the top of the next page, and perform the following steps.

4. Remove the ducting and removable panels from the front of the Cook'n'Vent so that you can access the gear motor arm.

5. Remove the four screws and the flat washer (on the cable clamp) from the J-box.
6. Remove the screw from the gear motor arm and remove the arm from the linkage in the roller track.
7. Remove the J-box from the intake and turn it around so the back faces you, then prop it up on the ledge over the fan opening.
8. **To remove the gear motor** (see the bottom illustration on the next page):
  - a) Remove the screw and lockwasher from the gear motor arm and remove the arm and key from the motor.
  - b) Remove the four screws from the gear motor and remove it from the J-box.
  - c) Disconnect the two wires from the motor terminals.

**IMPORTANT REASSEMBLY NOTE:** Make sure that you properly position the notch in the key so that it fits over the "V" in the gear motor shaft, and then slide the arm over the shaft and key. Secure the arm tightly with the lockwasher and screw.

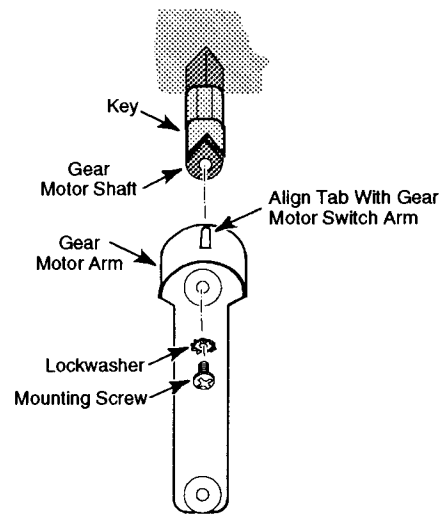

9. **To remove a gear motor switch or a vent switch** (see the bottom illustration on the next page):
  - a) Remove the wires from the switch terminals.
  - b) Remove the two mounting screws from the switch body and remove the switch.
10. Reassemble the vent.

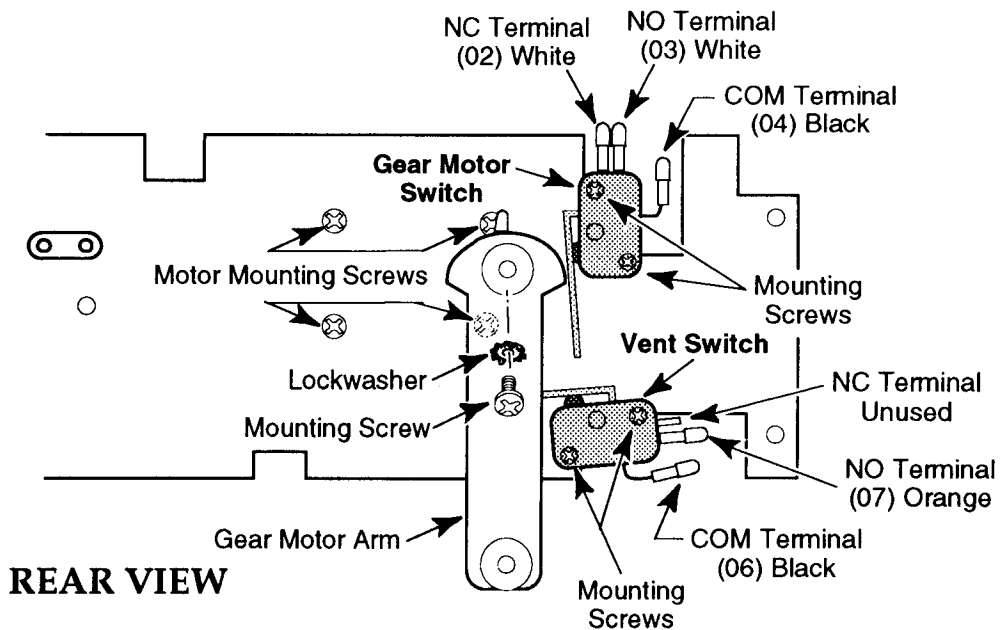
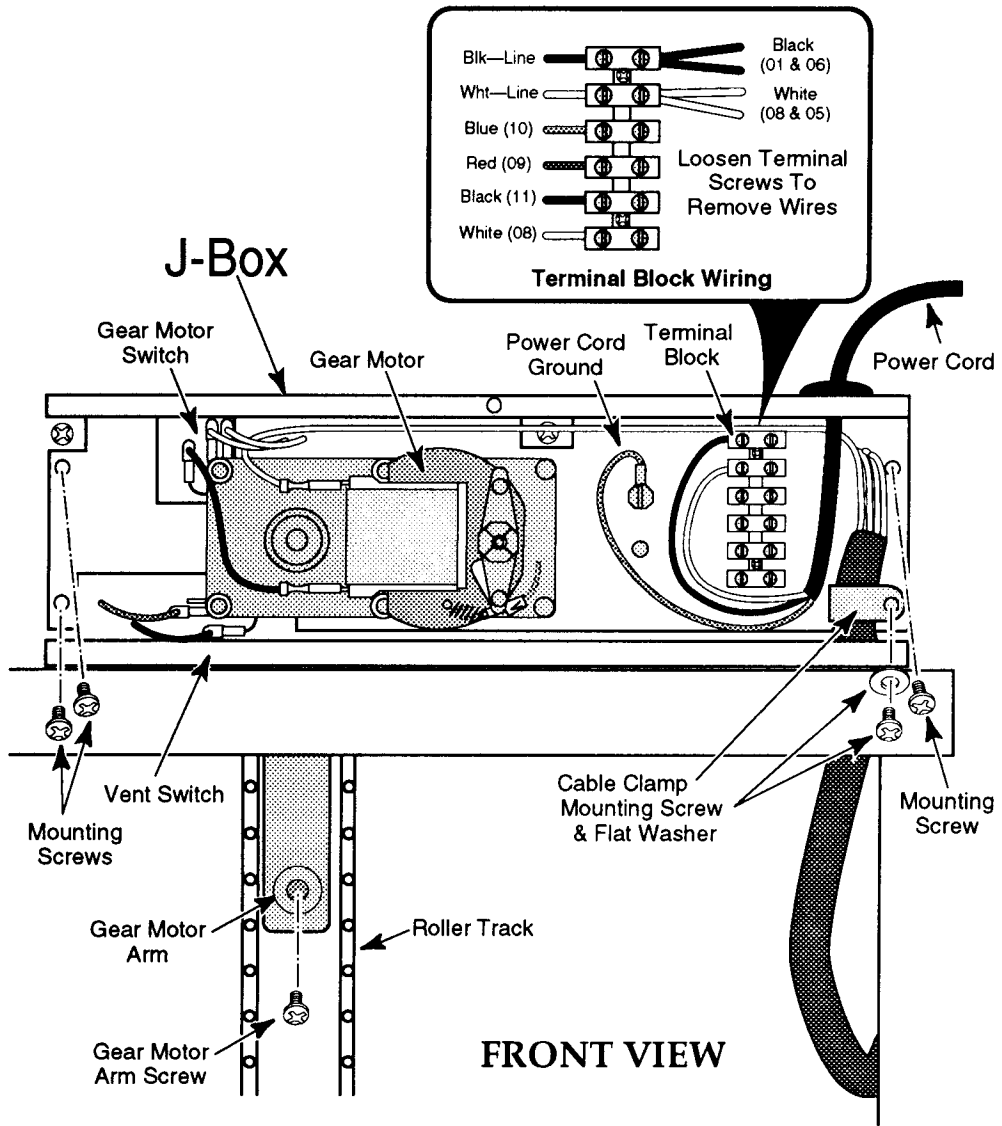

## REMOVING THE SNORKEL ASSEMBLY

### **WARNING**

Turn off the power circuit to the Cook'n'Vent at the main (house) junction box before servicing this unit.

### **CAUTION**

When you work on the Cook'n'Vent, be careful when handling the sheet metal parts. There are sharp edges present and you can cut yourself if you are not careful.

1. Lower the snorkel and turn off the electrical power going to the Cook'n'Vent.
2. Remove the blower or ducting from the front of the unit.
3. Remove the bracket hardware that is securing the unit to the cabinet floor, and remove the unit from its mounting location. Lay it on a padded work surface with the fan opening facing up. Be careful not to scratch any of the finished surfaces when you remove the snorkel.
4. Remove the screw from the gear motor arm and the hex nut, flat washer and spacer from the lower track stud, then remove the linkage and set it aside (see the top illustration on the next page).
5. Loosen the wingnuts from the channel covers and remove the panels.
6. Remove the six screws from the front panel (three on both sides) assembly and remove the panel and J-box from the unit.
7. Remove the six hex-washer nuts and the flat washer and screw (on the cable clamp) from the snorkel (see the bottom illustration on the next page).
8. Remove the snorkel assembly from the frame.
9. If you are replacing the entire snorkel, remove the top cap, the up/down, switch, and speed control switch (see pages 2-2 and 2-3).
10. Reassemble the snorkel and the vent.

— NOTES —



# TROUBLESHOOTING

When you troubleshoot the ventilator system, the following tools are recommended:

- Volt/Ohmmeter
- Magnetized phillips screwdriver

Use the following chart, along with the wiring diagram on page 3-3 and the strip circuits on 3-4, as a guide in helping you find and correct problems with the ventilator system.

## CHART

| SYMPTOM                           | POSSIBLE CAUSE   | TEST & CORRECTION   |
|-----------------------------------|--|---|
| Snorkel will not move up or down. | <ol style="list-style-type: none"> <li>1. Up/down switch is broken or shorted.</li> <li>2. Circuit breaker is tripped at main breaker box.</li> <li>3. Gear motor switch open.</li> <li>4. Gear motor winding open.</li> </ol>   | <ol style="list-style-type: none"> <li>1. Use ohmmeter and check switch continuity with contacts closed. Replace switch if defective.</li> <li>2. Check breaker (or fuse). If open, reset breaker or replace fuse.</li> <li>3. Gear motor switch should show continuity:               <ol style="list-style-type: none"> <li>a) Between terminals C and N.C. when in "up" position.</li> <li>b) Between terminals C and N.O. when in "down" position.</li> </ol>               Replace switch if checks show contacts are open.             </li> <li>4. Check continuity of winding in motor. Also check for power to motor. Replace motor if winding is open.</li> </ol> |
| Blower motor will not run.        | <ol style="list-style-type: none"> <li>1. Poor motor terminal connections.</li> <li>2. Open circuit through speed control.</li> <li>3. Circuit breaker is tripped at main breaker box.</li> <li>4. Vent switch is open.</li> <li>5. Blower motor windings open.</li> <li>6. Blower motor capacitor defective.</li> </ol> | <ol style="list-style-type: none"> <li>1. Check the blower motor connections and re-seat, if necessary.</li> <li>2. Check for power into and out of the speed control. If there is no power out, replace the control.</li> <li>3. Check breaker (or fuse). If open, reset breaker or replace fuse.</li> <li>4. Vent switch should show continuity between terminals C and N.O. when in "up" position. Replace switch if checks show contacts are open.</li> <li>5. Check windings for continuity. Replace blower motor, if open.</li> <li>6. Check capacitor with ohmmeter. Replace if open or shorted.</li> </ol>  |

| SYMPTOM                         | POSSIBLE CAUSE  | TEST & CORRECTION  |
|---------------------------------|---|--|
| Blower motor noisy.             | <ol style="list-style-type: none"> <li>1. Blower wheel out of balance.</li> <li>2. Blower motor shaft out of alignment.</li> </ol>  | <ol style="list-style-type: none"> <li>1. Adjust or replace blower wheel.</li> <li>2. Align shaft or replace motor.</li> </ol>   |
| Whistling noise when blower on. | <ol style="list-style-type: none"> <li>1. Air being drawn in behind snorkel assembly.</li> <li>2. Filters improperly installed.</li> </ol>  | <ol style="list-style-type: none"> <li>1. Install V-shaped weather seal (#2743) behind snorkel. NOTE: This weather seal is made by 3M, and is mounted in the gap at the top rear of the vent intake. The seal will block the blowing air and prevent the noise from occurring. A kit (#14-51-737) has been developed for this purpose.</li> <li>2. Straighten filters.</li> </ol>  |
| Weak air flow.                  | <ol style="list-style-type: none"> <li>1. Shipping bracket over inlet on remote blower.</li> <li>2. Ducting too small, too long, too many elbows or transition pieces.</li> <li>3. Ducting joints are leaking on remote blower.</li> <li>4. Ducting is obstructed.</li> <li>5. Blower unit does not move enough air (below rated VFPM (velocity-feet-per-minute)).</li> </ol> | <ol style="list-style-type: none"> <li>1. Remove bracket.</li> <li>2. Change ducting.</li> <li>3. Seal joints.</li> <li>4. Remove obstruction. Also check for a partially closed damper or a crushed duct.</li> <li>5. Replace smaller blower with special high-static blower.</li> </ol>  |
| Fan speed does not change.      | <ol style="list-style-type: none"> <li>1. Speed control is defective.</li> <li>2. Shipping bracket over inlet on remote blower.</li> <li>3. Ducting too small, too long, too many elbows or transition pieces.</li> <li>4. Ducting joints are leaking on remote blower.</li> <li>5. Ducting is obstructed.</li> </ol>   | <ol style="list-style-type: none"> <li>1. Set the voltmeter to 120 VAC. With power applied, touch the meter leads to the black and red control wire connectors. Vary the main control and look for a voltage change. If there is no change, the control is defective. If a change is noted, check the wiring between the control and the blower motor for an open circuit.</li> <li>2. Remove bracket.</li> <li>3. Change ducting.</li> <li>4. Seal joints.</li> <li>5. Remove obstruction. Also check for a partially closed damper or a crushed duct.</li> </ol> |

# WIRING DIAGRAM

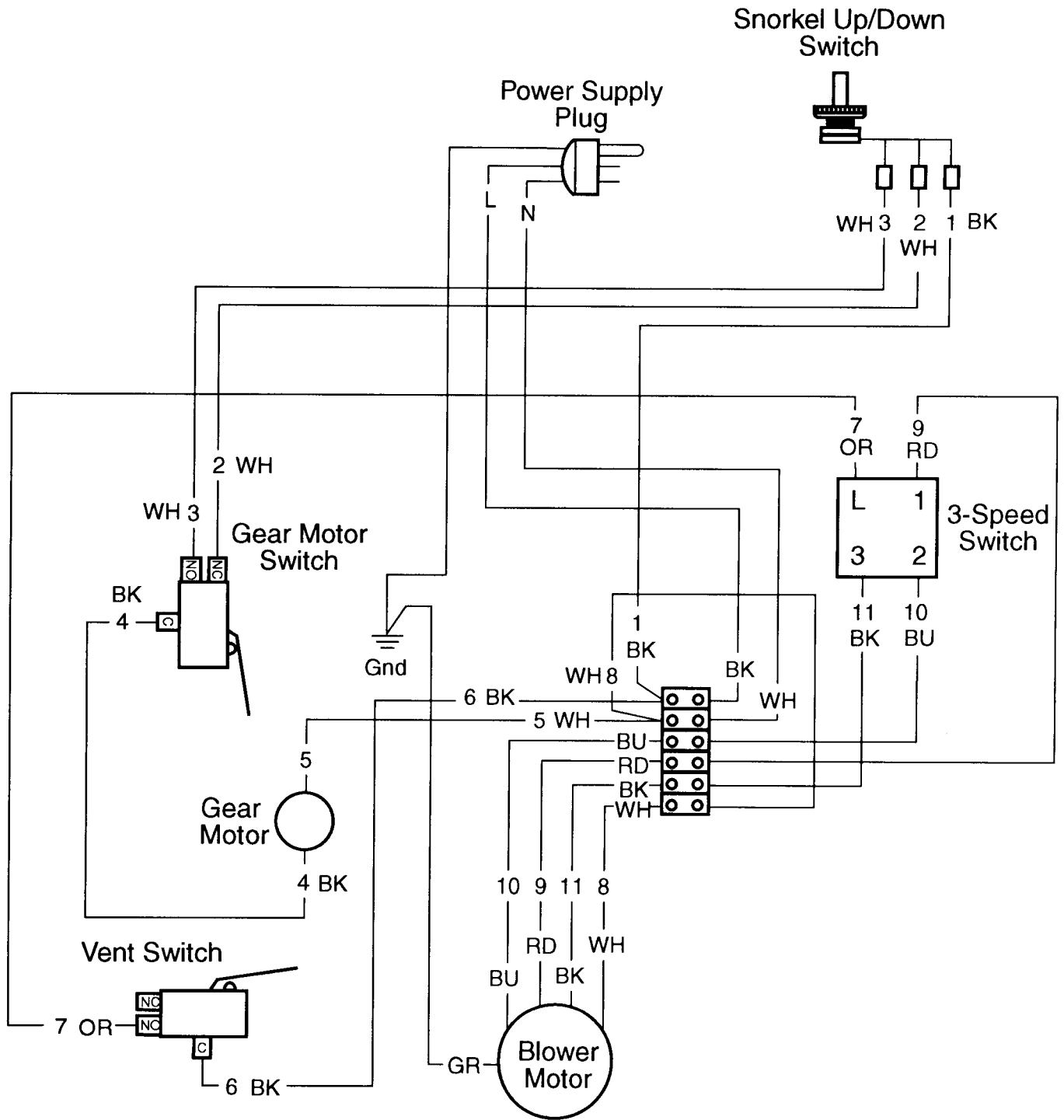

# STRIP CIRCUITS

## SNORKEL MOVING UP

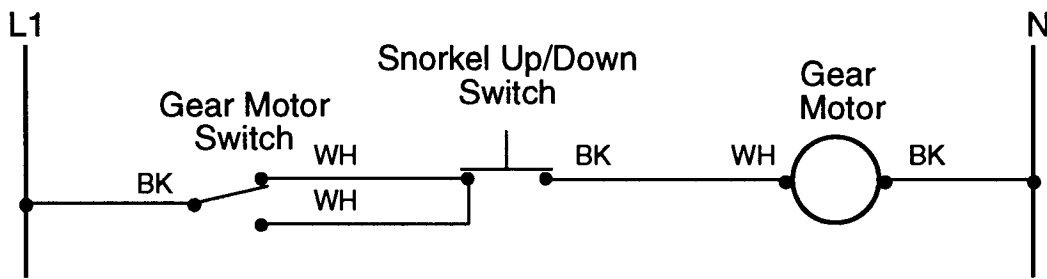

## SNORKEL MOVING DOWN

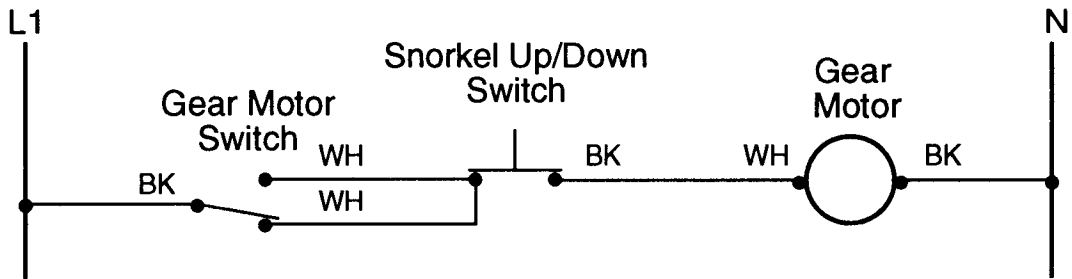

## SNORKEL UP—GEAR MOTOR RUNNING

