

Technical Service Manual

30 And 36 Inch All Gas Range



Models
E30GF74GPS, E36GF75GPS, E36GF76GPS



SAFE SERVICING PRACTICES - ALL APPLIANCES

To avoid personal injury and/or property damage, it is important that **Safe Servicing Practices** be observed. The following are some limited examples of safe practices:

1. **DO NOT** attempt a product repair if you have any doubts as to your ability to complete it in a safe and satisfactory manner.
2. Before servicing or moving an appliance:
 - Remove the power cord from the electrical outlet, trip the circuit breaker to the OFF position, or remove the fuse.
 - Turn off the gas supply and allow any residual gas to dissipate for 10 to 20 minutes.
3. Never interfere with the proper operation of any safety device.
4. **USE ONLY REPLACEMENT PARTS CATALOGED FOR THIS APPLIANCE. SUBSTITUTIONS MAY DEFEAT COMPLIANCE WITH SAFETY STANDARDS SET FOR HOME APPLIANCES.**
5. **GROUNDING:** The standard color coding for safety ground wires is **GREEN**, or **GREEN** with **YELLOW STRIPES**. Ground leads are not to be used as current carrying conductors. It is **EXTREMELY** important that the service technician reestablish all safety grounds prior to completion of service. Failure to do so will create a hazard.
6. Prior to returning the product to service, ensure that:
 - All electrical connections are correct and secure
 - All electrical leads are properly dressed and secured away from sharp edges, high-temperature components, and moving parts
 - All non-insulated electrical terminals, connectors, heaters, etc. are adequately spaced away from all metal parts and panels
 - All safety grounds (both internal and external) are correctly and securely connected
 - All panels are properly and securely reassembled

ATTENTION!!!

This service manual is intended for use by persons having electrical and mechanical training and a level of knowledge of these subjects generally considered acceptable in the appliance repair trade. Electrolux Major Appliances cannot be responsible, nor assume any liability, for injury or damage of any kind arising from the use of this manual.

SAFE SERVICING PRACTICES	2
QUICK REFERENCE SHEET	8
Serial nameplate location	8
Serial number breakdown	8
Gas electric requirement table	8
E30GF74GPS SAMPLE WIRING DIAGRAM	9
E36GF76GPS SAMPLE WIRING DIAGRAM	10
E36GF75GPS SAMPLE WIRING DIAGRAM	11
SECTION A - USE & CARE GUIDE	12
Finding information	12
Please read and save this guide	12
Important	12
Make a record for quick reference	12
Serial plate location	12
Product registration card	12
Questions	13
Important safety instructions	13
Safety precautions	13
Definitions	13
General precautions	13
Feature overview	15
Proper burner adjustments	15
Burner locations	16
Sealed burner configuration	16
Burner base, head & cap	16
Burner igniters	16
Cooktop features/surface cooking	17
Control knobs	17
Placement of burner grates	17
Flame adjustment	17
For most cooking	17
For deep fat frying	17
Surface cooking utensils	18
Using the accessory griddle (some models)	18
Using the integrated griddle	19
To grill food	19
To clean	19
Using the wok stand	19
To properly position the wok stand	20
Flat-bottom woks	20
Round-bottom woks	20
Using the simmer plate	20
Operation	20
Before cooking	20
Setting surface controls	21
Operating the control valves	21
Setting the burner flame height	22
Energy saving tips	22
Getting started	22
Before setting oven controls	22
Installing and removing oven rack supports	22
To remove the oven rack support	23
Removing and replacing oven racks	23
Arranging oven racks	23
To bake on a single rack	23

To bake on 2 racks _____	23
Baking layer cakes with 1 or 2 oven racks _____	24
Air circulation in the oven _____	24
Setting oven controls _____	24
Selector or knobs and functions _____	24
Ovan function _____	25
Standard bake _____	25
Convection cooking _____	25
Infrared broil _____	25
Baking _____	25
Oven vent _____	25
Baking problems _____	25
Baking problems, and solutions chart _____	26
Cooking instructions _____	27
Convection baking and roasting _____	27
General convection instructions for baking _____	27
To set oven for baking with the convection mode _____	27
To change the convection bake temperature _____	27
Baking problems _____	27
Convection baking and roasting _____	27
General convection instructions for roasting _____	27
To set oven for roasting with the convection mode _____	28
To change the convection mode temperature _____	28
Broiling _____	28
Preheating _____	28
To broil _____	28
Setting broil _____	29
To set the oven to broil _____	29
Broiling tips _____	29
Broiling times _____	29
Oven broiling recommendations _____	29
Broiling clean-up tips _____	30
Care and cleaning _____	30
Oven light _____	30
To replace the light bulb _____	30
Cleaning tips for range oven _____	30
Porcelain enamel oven _____	30
General cleaning _____	31
Cleaning the oven bottom _____	31
Cleaning tips for range cooktop _____	31
Cleaning stainless steel surfaces _____	32
Cleaning porcelain grates _____	32
Cleaning knobs and knob bezels _____	32
Cleaning burner bases _____	33
Cleaning burner heads or burner caps _____	33
Cleaning the burner igniters _____	33
General cleaning _____	33
Cleaning various parts of your appliance _____	33
Troubleshooting _____	35
Sample warranty _____	36
SECTION B - INSTALLATION INSTRUCTIONS _____	37
Read and save these instructions _____	37
Questions _____	37
Safety _____	37
Important safety instructions _____	37
Safety Precautions _____	37
For your safety _____	37

Preparing for installation _____	38
Verifying package contents _____	38
Gas and electric requirement table _____	38
Electrical power supply requirements _____	39
Gas and electrical rough-in _____	40
Locations _____	40
Cabinet and countertop preparation _____	41
General dimensions _____	42
Wood/composite overlay installation _____	44
Installing the anti-tip bracket _____	45
Installation steps _____	45
Installing the 36" range optional backguard _____	46
Installing the range optional backguard _____	46
Removing the oven door _____	46
Reinstalling the oven door _____	46
Grounding _____	47
Connecting range to gas supply _____	47
Installing the range _____	47
Make sure the anti-tip bracket is installed as directed _____	47
Installing the burner components _____	47
Operation _____	48
Verifying the operation _____	48
To ensure proper and safe operation _____	48
SECTION C - THEORY OF OPERATION _____	50
Gas flow _____	50
Top burner ignition and reignition system _____	53
Gas flow to the oven and broil burners _____	55
Gas flow 36" models with build-in griddle _____	55
Electrical operation of the oven and griddle burner _____	55
Oven circuit _____	56
Griddle circuit _____	57
Electrical operation of the convection fan motor _____	58
SECTION D - TROUBLESHOOTING _____	59
Electrical components will not operate _____	60
Burner flame too large and yellow _____	60
Burner flame too small _____	60
Flame goes out when the valve is turned to the simmer position _____	60
Top burners, not burning properly _____	60
One top burner, not burning properly _____	61
Top burner valve difficult to turn _____	61
Igniters do not spark when the burner knob is turned to the lite position _____	61
Igniters spark but burner does not ignite _____	61
Igniters continue to spark after burner is ignited _____	61
Oven does not operate in either bake or broil _____	62
The oven operates in broil, but not in bake _____	63
The oven operates in bake, but not in broil _____	63
Ovan calibration more than 20° off _____	63
One oven light does not work _____	63
Griddle is not operate (36 "model ranges) _____	64
Convection fan motor does not run when the switch is turned on _____	64
Ovan lights does not operate _____	64
SECTION E - TEARDOWN _____	65
Removing the top grates _____	65
Removing the simmer burner cap _____	65
Removing the simmer burner base _____	65
Removing the main burner head _____	65
Removing the main burner base _____	66

Removing the griddle cover (36" models with built-in griddle) _____	66
Removing the griddle grease tray _____	66
Removing the backguard _____	66
Removing the griddle (36 inch models with built-in griddle) _____	67
Removing the knob _____	67
Removing the knobs bezel _____	67
Removing the top burner orifice _____	68
Removing the simmer burner orifice _____	68
Releasing the control panel _____	68
Removing the control panel _____	68
Removing the oven light switch _____	69
Removing the convection fan switch _____	69
Removing the oven or griddle indicator lights _____	70
Removing the top burner valve switch _____	70
Removing the top bypass orifice _____	70
Removing the top simmer burner orifice _____	70
Removing the control panel trim _____	71
Removing the top burner valve _____	71
Removing the oven door _____	72
Removing the oven door seal _____	72
Removing oven door handle _____	73
Removing outer door panel assembly _____	73
Removing door handle studs _____	73
Removing the door hinges _____	74
Removing insulation cover plate _____	74
Removing door glass package _____	74
Removing door insulation _____	74
Removing oven rack glides _____	75
Removing oven bottom _____	75
Removing oven lights _____	75
Removing bake burner baffle _____	75
Removing the convection fan cover _____	75
Removing the convection fan blade _____	76
Removing the convection fan insulation cover _____	76
Removing the convection fan motor and mounting bracket _____	76
Removing the convection fan motor from the mounting bracket _____	77
Removing the rear panel _____	77
Removing the pressure regulator _____	77
Removing the top burner igniter module _____	78
Removing the convection fan relay _____	78
Removing the convection fan relay mounting bracket _____	78
Removing the broiler orifice shield _____	78
Removing the broiler burner seal _____	78
Removing the broiler orifice assembly _____	79
Removing the oven vent _____	79
Removing the flexible tubing between the broiler valve in the broiler orifice _____	79
Removing the broiler safety valve _____	79
Removing the broiler safety valve mounting bracket _____	80
Removing the broiler burner igniter _____	80
Removing the broiler igniter mounting bracket _____	81
Removing the broiler burner _____	81
Removing the oven vent covers _____	81
Removing the kick panel _____	82
Removing the bake burner safety valve _____	82
Removing the bake burner safety valve mounting bracket _____	83
Removing the bake burner orifice assembly and mounting bracket _____	83
Removing the bake burner orifice _____	83

Removing the bake burner igniter _____	84
Removing the bake burner _____	84
Removing the bake burner igniter ceramic wire guide _____	84
Removing the bake burner mounting bracket _____	85
Removing the bake burner side baffles _____	85
Removing the side panel front trims _____	85
Removing the body side front trim bottom bracket _____	86
Removing the body side _____	86
Removing the insulation side panels _____	86
Removing the door hinge guides _____	87
Removing the griddle orifice assembly (36 inch models with built-in griddle) _____	87
Removing the griddle orifice (36 inch models with built-in griddle) _____	88
Removing the griddle igniter _____	88
Removing the griddle igniter bracket _____	89
Removing the griddle burner _____	89
Removing the center divider (30 inch models) _____	89
Removing the drip pans _____	90
Removing the oven thermostat _____	90
Removing the simmer burner orifice assembly _____	91
Removing the top burner orifice assembly _____	91
Releasing the top burner orifice mounting plate assembly _____	92
Removing the top burner igniter _____	92
Removing the top burner orifice mounting plate assembly _____	93
Removing the main base _____	93
Removing the main base insulation shield _____	94
Removing the leveling legs _____	94

QUICK REFERENCE SHEET

1. Serial nameplate location:

On the frond framed between the oven door and kick plate.

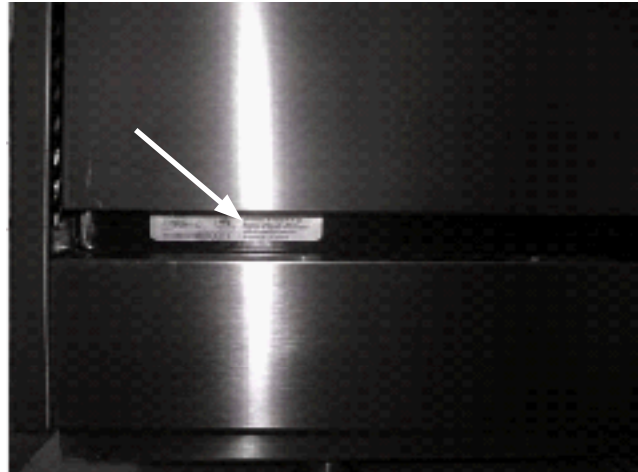

2. Serial number breakdown.

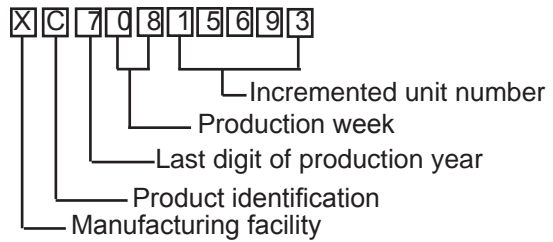

3. **GAS AND ELECTRIC REQUIREMENT TABLE**

Model No.	Electrical Circuit	Total Connected	Gas Type	Manifold Pressure Water Column Inches	Minimum Gas Supply Water Column Inches
E30GF74GPS	120 VAC 60 Hz	5A	Natural	5"	6"
E36GF75GPS	120 VAC 60 Hz	8A	Natural	5"	6"
E36GF76GPS	120 VAC 60 Hz	5A	Natural	5"	6"

4. Burner btu rating refer to serial name plate

**SAMPLE WIRING DIAGRAM ALWAYS REFER TO
THE WIRING DIAGRAM WITH THE PRODUCT**

E30GF74GPS Wire Diagram

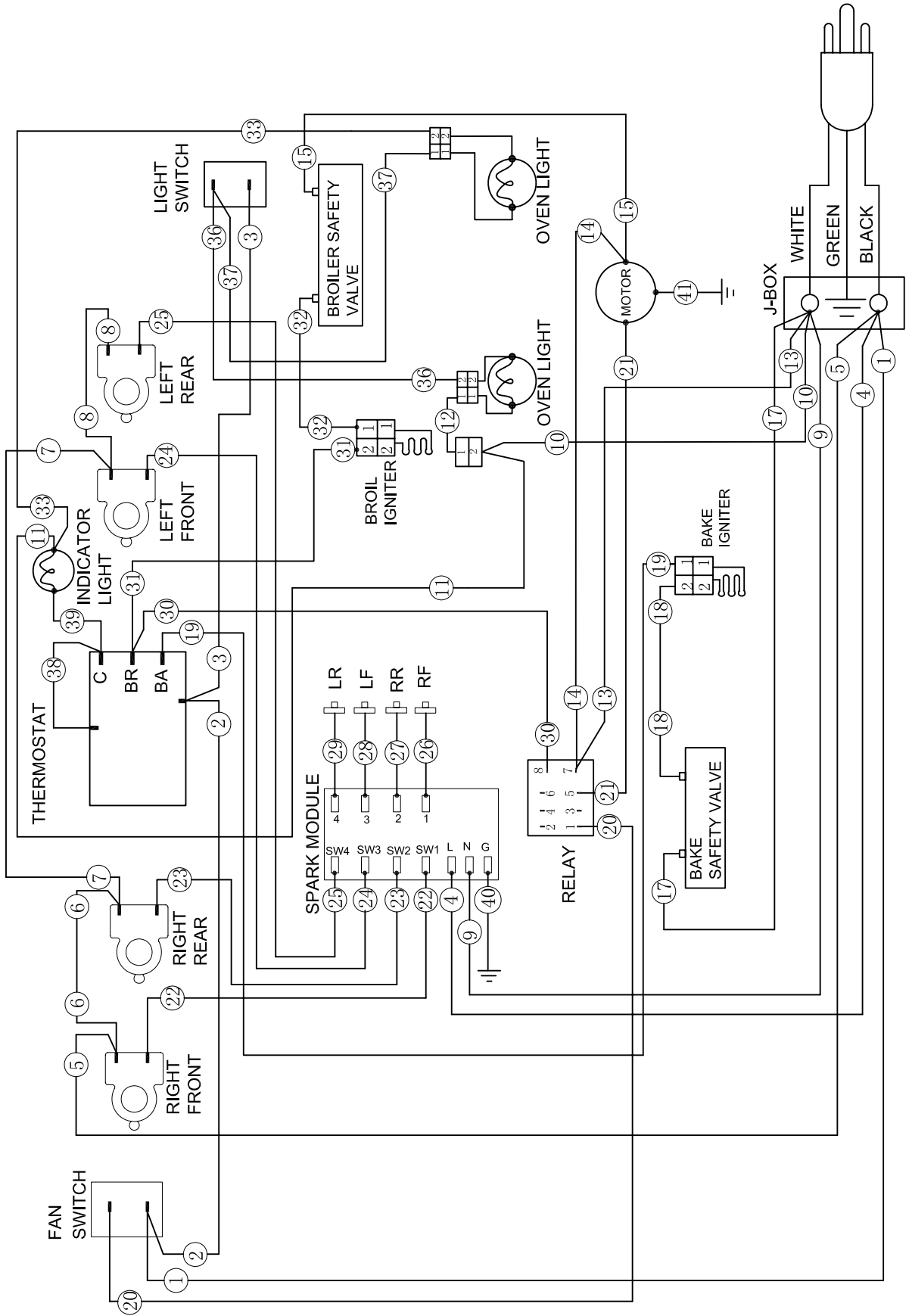

**WIRING DIAGRAM MODEL E36GF76GPS
 SAMPLE WIRING DIAGRAM ALWAYS REFER TO
 THE WIRING DIAGRAM WITH THE PRODUCT**

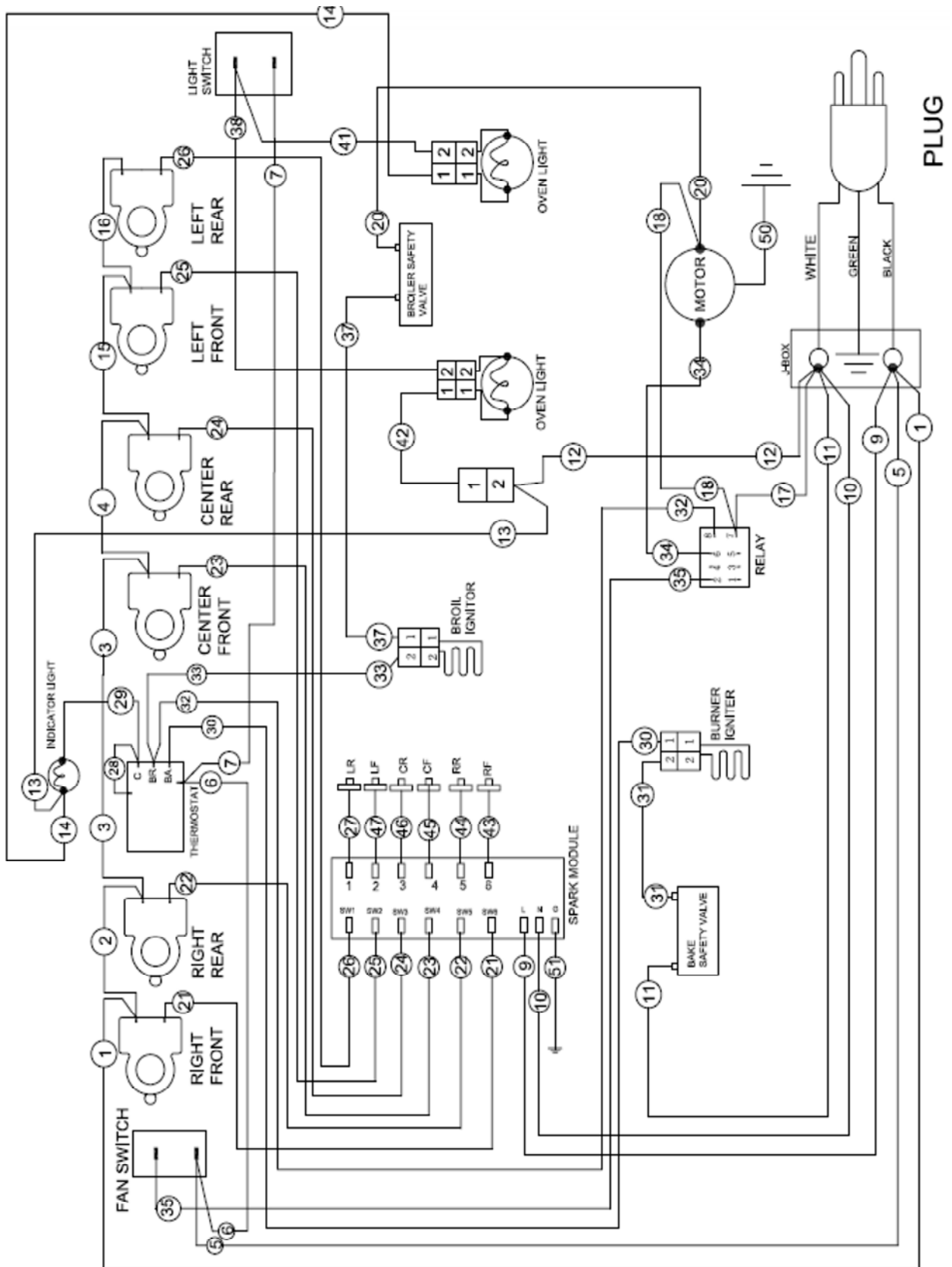

**WIRING DIAGRAM MODEL E36GF75GPS
 SAMPLE WIRING DIAGRAM ALWAYS REFER TO
 THE WIRING DIAGRAM WITH THE PRODUCT**

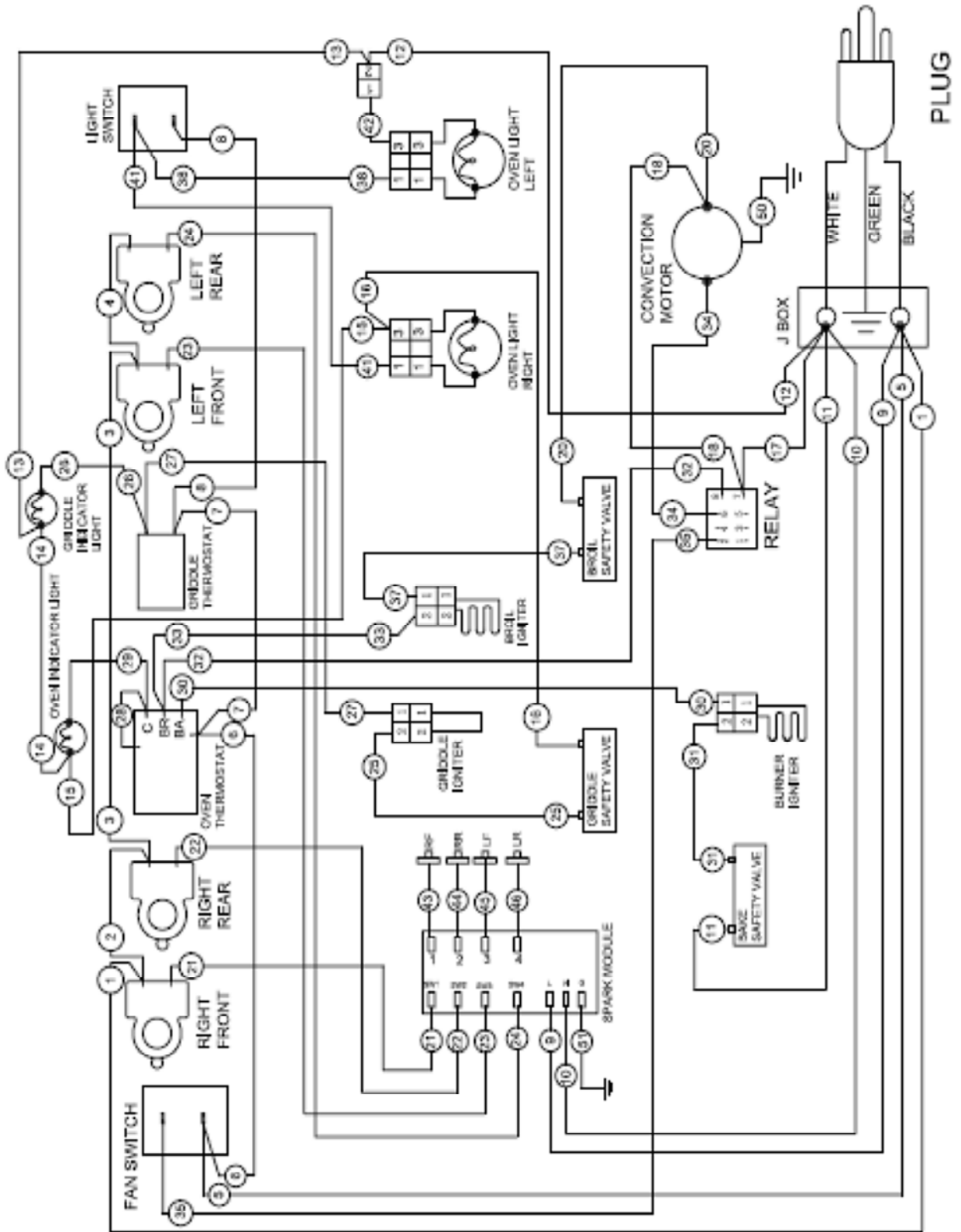

SECTION A - USE & CARE GUIDE

Finding Information

PLEASE READ AND SAVE THIS GUIDE

Thank you for choosing Electrolux, the new premium brand in home appliances. This Use & Care Guide is part of our commitment to customer satisfaction and product quality throughout the service life of your new appliance.

We view your purchase as the beginning of a relationship. To ensure our ability to continue serving you, please use this page to record key product information.

IMPORTANT

PLEASE READ all instructions completely before attempting to install or operate the appliance.

Once you have your appliance installed, we suggest you keep this manual in a safe place for future reference. Should any problems occur, refer to the Troubleshooting section of this manual. This information will help you quickly identify a problem and get it remedied. In the event you require assistance, please contact the dealer where you purchased your appliance.

MAKE A RECORD FOR QUICK REFERENCE

Whenever you call to request information or service, you will need to know your model number and serial number (Figure 1). You can find this information on the appliance's serial plate and on the product registration card.

SERIAL PLATE LOCATION

Between the oven door and range front kickplate on the left side. (See figure 1)

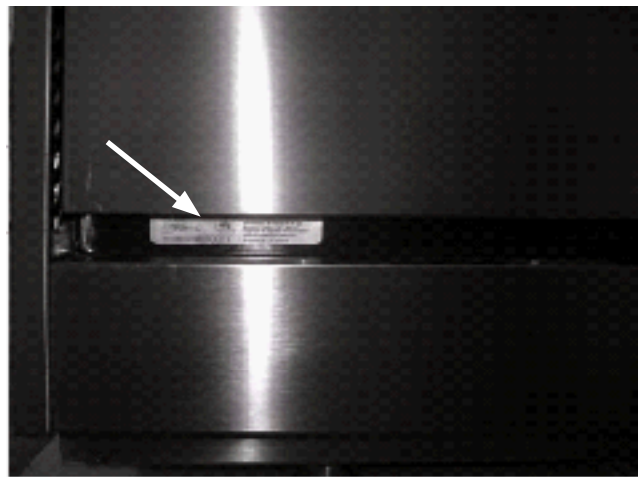

Figure 1

PRODUCT REGISTRATION CARD

The package containing this manual also includes your product registration information. Warranty coverage begins at the time your Electrolux appliance was purchased.

If you received a damaged product, immediately contact your dealer or builder. Do not install or use a damaged appliance.

NOTE: Registering your product with Electrolux enhances our ability to serve you. You can register online (at the Internet address below) or by dropping your Product Registration Card in the mail. Complete and mail the Product Registration Card as soon as possible to validate the registration date.

Please record the purchase date of your Electrolux appliance and your dealer's name, address and telephone number.

Purchase Date

Electrolux Model Number

Electrolux Serial Number

Dealer Name

Dealer Address

Dealer Telephone

Keep this manual and the sales receipt together in a safe place for further reference.

QUESTIONS

For toll-free telephone support in the U.S. and Canada: 1-877- 4ELECTROLUX (1-877-435-3287)

For online support and Internet product information: www.electroluxusa.com

IMPORTANT SAFETY INSTRUCTIONS

Safety Precautions

Do not attempt to install or operate your appliance until you have read the safety precautions in this manual. Safety items throughout this manual are labeled with a Warning or Caution based on the risk type.

Definitions



This is the safety alert symbol. It is used to alert you to potential personal injury hazards. Obey all safety messages that follow this symbol to avoid possible injury or death.



WARNING

WARNING indicates a potentially hazardous situation which, if not avoided, could result in death or serious injury.



CAUTION

CAUTION indicates a potentially hazardous situation which, if not avoided, may result in minor or moderate injury.

CAUTION

CAUTION used without the safety alert symbol indicates a potentially hazardous situation which, if not avoided, may result in property damage.

IMPORTANT

IMPORTANT Indicates installation, operation or maintenance information which is important but not hazard related.

General Precautions

IMPORTANT

- Begin by ensuring proper installation and grounding of the appliance by a qualified technician according to the accompanying Installation Instructions. Have the installer show you where the fuse or junction box is located so that you know how and where to turn off power. Also, have the installer show you the location of the gas supply. If you smell gas, do not use the appliance. Immediately turn off the gas supply at the shut off valve, disconnect electrical power to the appliance at the fuse or junction box and contact the gas supplier or qualified appliance technician.
- Ensure that the appliance is used only by those individuals who are able to operate it properly.
- Use the appliance only for cooking tasks expected of a home appliance as outlined in this manual.
- Properly clean and maintain as recommended in this manual, cleaning only the parts listed.
- Use only dry potholders to avoid steam burns when removing hot cookware.
- In the event that a burner flame goes out and gas escapes, open a window or door. Wait at least 5 minutes before attempting to use the cooktop.
- Select utensils of the proper size, material and construction for the particular type of cooking being done. Select utensils that are large enough to contain food without boil-overs or spillovers. Choose pans with easily grasped handles that will stay cool while cooking. Do not use utensils with loose handles. Avoid using pans that are too heavy to lift safely. Use cookware only for its intended purpose. Certain types of glass, ceramic, and earthenware utensils are suitable for use only in an oven and not in cooktop applications.
- When cooking, set the burner controls so that the flame heats only the bottom of the utensil and does not extend up the sides of the utensil.
- When deep fat frying, be certain that the pan is large enough to contain the desired volume of food without overflow caused by bubbling of the fat. Never leave a deep fat fryer unattended. Avoid deep fat frying of moist or frost-covered foods. Foods with high water content may cause spattering or spilling of the hot fat. Heat fat slowly and stir together any combinations of oils

and fats prior to applying heat. Utilize a deep fat frying thermometer to avoid heating the fat to temperatures above the flash point.

- Always turn pan handles to the side or back of the cooktop. Do not turn handles towards the room where they are easily hit. Handles should not extend over adjacent burners.
- Always check the positions of the control knobs to make sure the cooktop is off when you are finished cooking.
- Before performing any service, turn off the gas supply by closing the gas shut-off valve and turning off the electrical power supply.
- Always light each burner prior to placing a utensil on the burner grate. Also, turn the control knob to the "off" position before removing a utensil from the burner grate.
- Always clean the appliance cautiously. If using a damp sponge or cloth, wait until the cooktop has cooled sufficiently to prevent steam burns. Also, some cleaners can produce harmful or unpleasant fumes if applied to hot surfaces.
- Clean only those parts listed in this manual.
- Keep any ventilation filters clean to avoid grease fires.
- Always set utensils gently onto the grates and center them so that they are well balanced.
- Always keep the cooktop surface clean and dry.
- This cooktop is designed as a cooking appliance. Never use it for warming or heating a room.
- Before performing any service, turn off the gas supply by closing the gas shut-off valve and turning off electrical power supply.
- Use this appliance only for its intended use as described in this manual. Do not use corrosive chemicals or vapors with this appliance. This type of appliance is not designed for industrial or laboratory use.
- Exercise caution when opening the oven door. Let hot air or steam escape before looking or reaching into the oven.
- Position oven racks in desired locations when the oven is cool. (If a rack must be repositioned after

the oven is already hot, be certain that potholders are used.

- In the event that a burner flame goes out and gas escapes, turn off the gas control and open a window or door. Wait at least 5 minutes before attempting to use the cooktop or oven.



CAUTION

- Do not use the appliance for warming or heating the room.
- Do not leave children alone or unattended in the area where the appliance is in use. Never allow children to sit or stand on any part of the appliance. Do not let children play with the appliance.
- Do not store items of interest to children above the range. Children could be burned or injured while climbing on the appliance.
- Do not wear loose or hanging apparel while using the cooktop.
- Do not store combustible, flammable or explosive materials on the cooktop, in the oven, or in adjacent cabinets.
- Do not attempt to repair or replace any part of the appliance unless specifically recommended in literature accompanying this appliance. All other service should be referred to a qualified technician.
- Do not use water on grease fires. A violent steam explosion may result. Smother any flames with a lid, cookie sheet or flat tray. Flaming grease can be extinguished with baking soda or a multipurpose chemical or foam extinguisher.
- Do not allow potholders to touch gas burners. Do not use a towel or bulky cloth as a potholder.
- Do not block or obstruct the holes beneath the control knobs. Blocking these holes may affect burner operation and may result in a hazard.
- When using the cooktop, do not touch the grates, burner caps, burner bases, or any other parts in proximity to the flame. These components may be hot enough to cause burns.
- If the cooktop is near a window, do not use long curtains as a window treatment. They can blow

over the cooktop and create a fire hazard.

- Do not cover the burners and grates with anything except properly selected utensils. Decorative covers should not be used.
- Do not heat unopened food containers such as baby food jars and cans. Pressure buildup may cause the container to burst and cause injury.
- Do not use abrasive or caustic cleaners or detergents on this appliance, as these may cause permanent damage. Do not use aerosol cleaners, as these may be flammable or cause corrosion of metal parts.
- Do not use or attempt to use this appliance in the event of a power failure.
- Do not slide cookware across the grates. Sliding may damage the finish of the grates. Lift utensils to reposition them.

WARNING

Severe shock, or damage to the appliance may occur if the appliance is not installed by a qualified installer or electrician.

WARNING

NEVER use this appliance as a space heater to heat or warm the room. Doing so may result in carbon monoxide poisoning and overheating of the appliance.

Feature Overview

Before using your range, become familiar with the features and control panel layout. See Figure 22 for a detailed control panel layout for your model.

- | | |
|-----------------------|---------------------|
| 1. Control Panel | 2. Infrared Broiler |
| 3. Convection Fan | 4. Bake Burner |
| 5. Oven Door | 6. Oven Racks |
| 7. Oven Rack Supports | 8. Oven Rack Glides |



PROPER BURNER ADJUSTMENTS

The color of the flame is the key to proper burner adjustment. A good flame is clear, blue and hardly visible in a well-lighted room. Each cone of flame should be steady and sharply defined. Adjust or clean burner if flame is yellow-orange. To clean burner, see instructions under **General care & cleaning**.

BURNER LOCATIONS

All Electrolux Icon cooktops are equipped with sealed burners. See Figure 2 for a detailed burner layout for your model.



E36GF75GPS



E30GF74GPS



E36GF76GPS

Figure 2

SEALED BURNER CONFIGURATION

On ICON all-gas ranges, there are a total of four (4) or six (6) burners, all rated with a maximum of 15K btu. Additionally, all burners are equipped with a slow simmer setting rated at 620 btu. The knobs are grouped in twos (Figure 2).

On ICON 36" gas all-ranges (Model EGF76GPS), there is a central griddle rated at 18.5K btu. The same 15K btu burners are equipped with the low simmer settings of 620 btu on this model.

BURNER BASE, HEAD & CAPS

The burner heads spread the flame evenly around the burner perimeters. The burner heads must seat properly in the burner bases to enable proper cooktop operation. To ensure proper seating, the burner heads are keyed using a hole which aligns with the ignitor.

BURNER IGNITERS

A burner igniter is located on each gas burner base. When a control knob is rotated more than 90 degrees counterclockwise, the igniter will spark and the selected burner will ignite. Additionally, due to the automatic re-ignition feature, the igniters will spark automatically if a flame should blow out or be severely distorted by a draft or by a ventilation system. Burner igniters must always be kept clean and dry to function properly. Dirty or wet igniters will result in constant sparking, even if there is a flame present. See Figure 3.

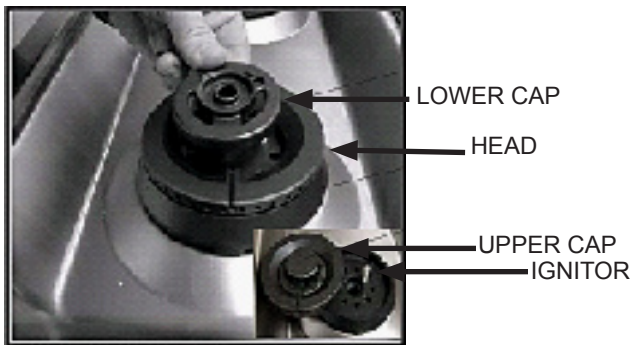

Figure 3

Cooktop Features/Surface Cooking

CONTROL KNOBS

The control knobs provided with this cooktop are designed for ease of use and longevity. The “D” shaped design of the knob shaft ensures proper orientation when reinstalling the knob. Located beneath each knob is a bezel ring that mounts to the cooktop.

PLACEMENT OF BURNER GRATES

Place grates on the porcelain coated spill tray. See Figure 4. Be sure they are located correctly inside the stainless steel frame.



Figure 4

IMPORTANT

Do not slide the grates on the stainless steel frame. Doing so can damage the surface.

FLAME ADJUSTMENT

For most cooking, start on the highest control setting

and then turn to a lower one to complete the process. Use the chart below as a guide for determining proper flame size for various types of cooking. The size and type of utensil used and the amount of food being cooked will influence the setting needed for cooking.

For deep fat frying, use a thermometer and adjust the surface control knob accordingly. If the fat is too cool, the food will absorb the fat and be greasy. If the fat is too hot, the food will brown so quickly that the center will be undercooked. Do not attempt to deep fat fry too much food at once as the food will neither brown nor cook properly.

*Flame Size	Type of Cooking
High Flame	Start most foods; bring water to a boil; pan broiling.
Medium Flame	Maintain a slow boil; thicken sauces, gravies; steam.
Low Flame	Keep foods cooking; poach; stew.

*These settings are based on using medium-weight aluminum pans with lids. Settings may vary when using other types of pans.

Never extend the flame beyond the outer edge of the utensil. A higher flame simply wastes heat and energy, and increases your risk of being burned by the flame.

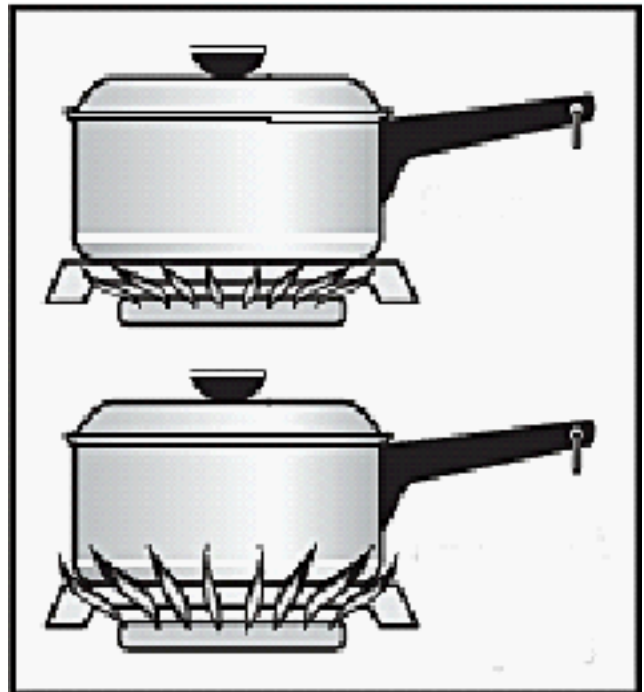

Figure 5

SURFACE COOKING UTENSILS

*GOOD



- Flat bottom and straight sides.
- Tight fitting lids.
- Weight of handle does not tilt pan. Pan is well balanced.
- Pan sizes match the amount of food to be prepared and the size of burner.
- Made of material that conducts heat well.
- Easy to clean.

* POOR

- Curved and warped pan bottoms.



- Pan overhangs cooktop by more than 2.5 cm (1”).



- Heavy handle tilts pan.



- Flame extends beyond cooktop.



Note: Always use a utensil for its intended purpose. Follow manufacturer’s instructions. Some utensils were not made to be used in the oven or on the cooktop.

USING THE ACCESSORY GRIDDLE (SOME MODELS)

Side with grill



Figure 6 Side with grill

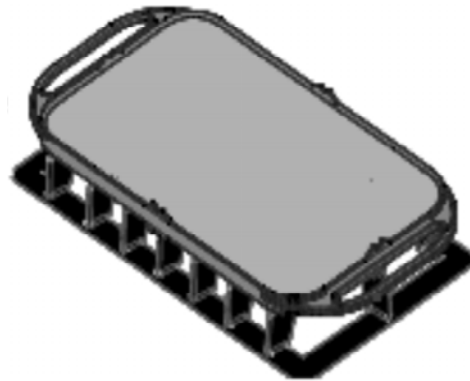

Figure 7 Flat side

The griddle is intended for direct food cooking and can be used on both sides (Figures 6 and 7). Do not use pans or other cookware on the griddle. Doing so could damage the finish. With the grate in position over the burner, set the griddle on top of the grate positioning the notches in the griddle over the grate fingers.



CAUTION

Always place the griddle on the grate before turning on the burner.

Always use potholders to remove the griddle from the grate. Allow the griddle to cool before removing. Do not set hot griddle on surfaces that cannot withstand high heat; such as countertops.

Be sure the griddle is positioned correctly and stable before use to prevent hot spills and possible burns.

USING THE INTERGRATED GRIDDLE

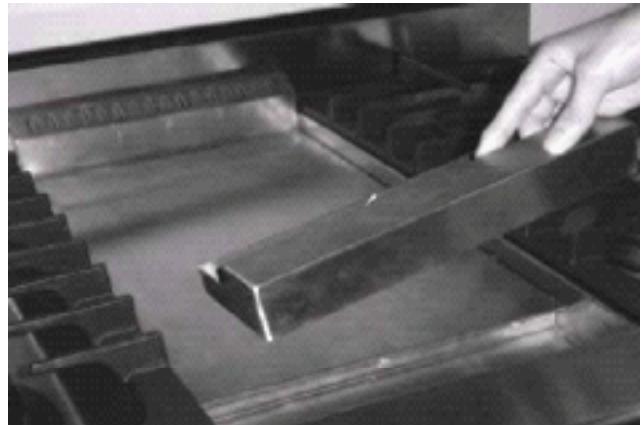
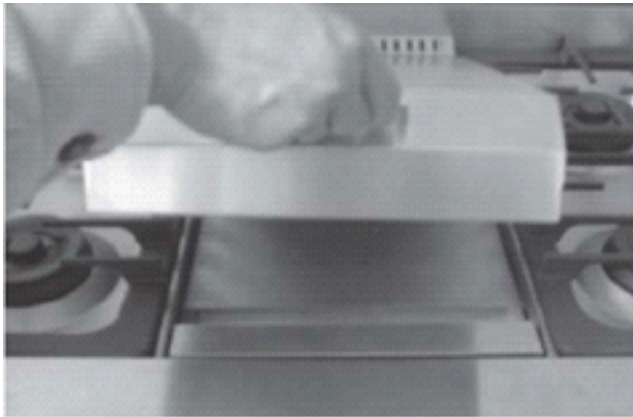
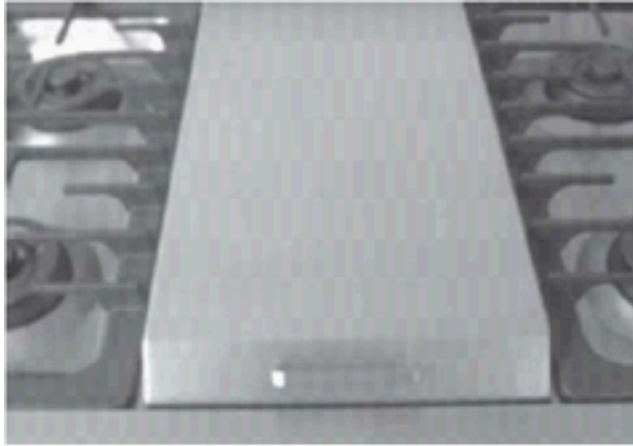

Figures 8

To Grill Food:

1. Remove grill cover.
2. Set temperature using the grill control knob and cook food directly on the flat surface of grill.
3. Replace the cover after griddle has cooled.

To Clean:

1. Allow grill to cool. Remove grease tray and dispose of grease .
2. Clean the empty tray with detergent and water using paper towels, dish cloth or sponge.

NOTE: Discoloration of the grill cooking surface is normal.

USING THE WOK STAND

The Wok Stand provided with your cooktop is designed to allow round-bottomed woks to be used. It is recommended that you use a 14 inch diameter (35.5 cm) or less Wok. Also, using the front burners with the wok stand will produce the best results. If properly positioned, the Wok Stand will not slide off the grate.

CAUTION

Always use potholders to remove the wok stand from the grate. Allow the wok stand to cool before removing. Do not set hot wok stand on surfaces that cannot withstand high heat; such as counter-tops.

Be sure the Wok Stand is positioned correctly and stable before use to prevent hot spills and possible burns.

To Properly Position the Wok Stand:

With the grate in position over the burner, set the Wok Stand on top of the grate positioning the center of the Wok Stand over the center of the cooktop grate fingers (See **Figure 10**).



Flat-bottom woks with large flat bottoms may also be used on your cooktop Surface Burner Grates without the Wok Stand. Insure the stability of the flat-bottom wok before cooking without the Wok Stand. If unstable, DO NOT use the flat-bottom wok without the Wok Stand.

Round-bottom woks (with a support ring) should NOT be used. The supporting ring was not designed for proper or stable use on the Surface Burner Grates.

CAUTION

Be sure to **ALWAYS** use the Wok Stand if the stability of the wok is uncertain. If cooking large amounts of liquid food without the Wok Stand, the wok may tip and spill over causing burns.

USING THE SIMMER PLATE

The Simmer Plate has been specifically designed for simmering and holding food at the lowest safe temperature. It can be used for cooking sauces long periods of time, or melting chocolate. With the grate in position over the burner, set the simmer plate on top of the grate, centering the plate over the grate fingers (See **Figure 11**).

Figure 11

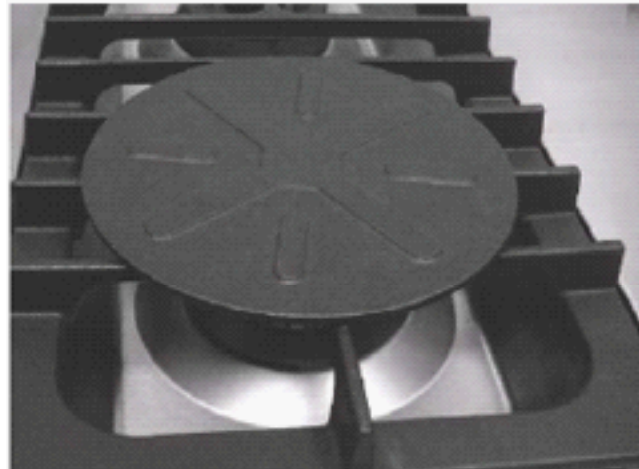

Then place the utensil on the simmer plate. The Simmer Plate is to be used by setting the burner to its lowest setting. The Simmer Plate is intended to be used for simmering only. The Simmer Plate must be removed when cooking.

CAUTION

Always place the simmer plate on the grate before turning on the burner.

Always use potholders to remove the simmer plate from the grate. Allow the simmer plate to cool before removing. Do not set hot simmer plate on surfaces that cannot withstand high heat; such as countertops.

Be sure the simmer plate is positioned correctly and stable before use to prevent hot spills and possible burns.

Operation

BEFORE COOKING

Ensure that the range has been installed by a qualified individual who has tested the operation of the cooktop and oven in accordance with the Installation Instructions. The burner rings, burner caps, grates, and knobs must be in place for the cooktop to operate properly. All cooktop components must be clean. Be certain that the gas and electrical power supplies to the range are operational.

Read this **Use and Care Manual** in its entirety prior to operating the cooktop and oven.

SETTING SURFACE CONTROLS

Your range is equipped with burners which allow high, standard, and simmer cooking.

Simmer Setting Burner: best used for simmering delicate sauces, etc.

Standard Setting Burner: used for most all surface cooking needs. Always select a utensil that is suitable for the amount and type of food being prepared. Select a flame size appropriate to the pan. Never allow flames to extend beyond the outer edge of the pan.

Your cooktop is also equipped with 240° rotation flame control valves. These valves provide enhanced control of the burner flame. Each burner lights automatically from an electric igniter when its control knob is turned counter clockwise from the "OFF" position to the "hi" position.

OPERATING THE CONTROL VALVES

To light a particular burner, press in on the corresponding control knob, then immediately rotate the knob counter clockwise from the "OFF" position to the "hi" position. **The burner igniters will spark continuously until the gas ignites on the selected burner. The igniters will stop sparking as soon as the burner ignites.**

Once the burner is lit, reduce the flame height if desired by rotating the control knob further counterclockwise, then place the utensil on the grate.



Figure 12
Burner Control Valve



WARNING

Do not touch any burner caps, burner base, burner head, or igniter while the igniters are sparking, as an electrical shock could result.

IMPORTANT

- If the gas does not ignite within four seconds, turn off the valve. Allow at least two minutes for any gas to dissipate, then repeat the lighting procedure.
- Burner igniters must always be kept clean and dry to function properly. Due to the reignition feature, dirty or wet igniters will result in constant sparking, even if there is a flame present. Additionally, igniters will spark automatically if the flame is distorted by a draft or by a cooktop ventilation system. Eliminate the draft or reduce the ventilation blower speed in this case.
- When the cooktop is cool and/or more than two burners are in use, the igniters may continue to spark if the control knob is set to the "LOW" position. This is normal until the burner warms up. The tendency to spark under these conditions can be reduced by operating the burner at a higher flame setting for a short period of time (normally 60 seconds or less), then adjusting the control knob down to the "LOW" setting. The burner will also warm up faster if a utensil is placed on the grate.
- The flame should be steady and blue in color. Foreign material in the gas line, especially in new construction, may cause an orange cooktop flame during initial operation. This will disappear with further use.
- The flame should burn evenly around the perimeter of the burner. If the flame is uneven, ensure that the burner base, heads and caps are properly positioned, then check for any foreign material in the burner ring or on the burner cap. Remove any foreign material with a straightened paper clip, wire, or needle. Do not use a toothpick to remove clogs, as it could break off. Do not damage or distort the shape of the burner ring ports.
- Never light the burners with a match or other open flame. If a burner does not ignite, refer to the Troubleshooting Guide.

CAUTION

Do not place plastic items such as salt and pepper shakers, spoon holders or plastic wrappings on top of the cooktop when it is in use. These items could melt or ignite. Potholders, towels or wood spoons could catch fire if placed too close to a flame.

SETTING THE BURNER FLAME HEIGHT

Setting the proper burner flame height for the desired cooking process and selected utensil will result in superior cooking performance, while also saving time and energy. Follow these recommendations for best results:

1. Use low or medium flame heights when cooking in utensils that are poor conductors of heat, such as glass, ceramic, and cast iron cooking vessels. Reduce the flame height until it covers approximately 1/3 of the utensil diameter. This will ensure even heating within the utensil and reduce the likelihood of burning or scorching of food.
2. Reduce the flame if it is extending beyond the bottom of the utensil. A flame that extends up the sides of the utensil is potentially dangerous, heats the utensil handle and kitchen instead of the food, and wastes energy.
3. Reduce the flame height to the minimum level necessary to perform the desired cooking process. Remember that food cooks just as quickly at a gentle boil as it does at a vigorous, rolling boil. Maintaining a higher boil than is necessary wastes energy, cooks away moisture, and causes a loss in food flavor and nutrient level.

ENERGY SAVING TIPS

- Always use utensils with flat, smooth bottoms and tight-fitting lids to retain heat and moisture.
- Minimize the amount of liquid or fat to reduce cooking times.
- Select cookware of the proper size, material and construction for the cooking process being performed.
- Adjust the flame height to fit the utensil size.
- After liquid reaches a boil, reduce the heat to maintain a simmer rather than a rolling boil.

- Use a timer rather than repeatedly removing the lid to check food.
- Thaw foods prior to cooking to reduce cooking time.

Getting Started

BEFORE SETTING OVEN CONTROLS

Installing and Removing Oven Rack Supports

ALWAYS INSTALL OVEN RACK SUPPORT BEFORE TURNING ON THE OVEN (WHEN THE OVEN IS COOL).

To install oven rack support, align and insert in the 2 rear tabs of the rack supports to the rear holes in the oven side wall. Then align the 2 front tabs of the rack support to the front holes in the oven side wall. Push in on rack supports to secure end wall.

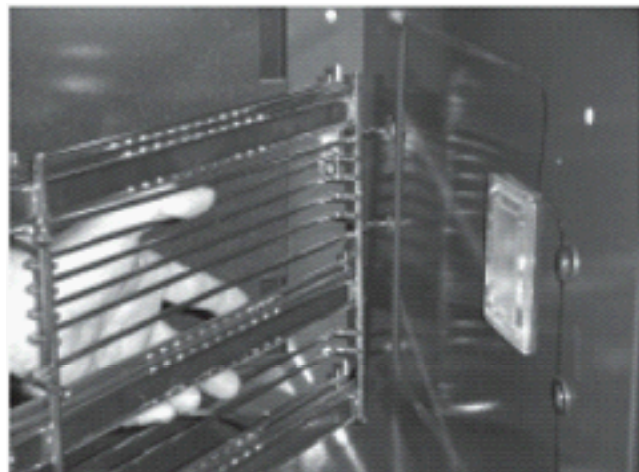

Figure 13

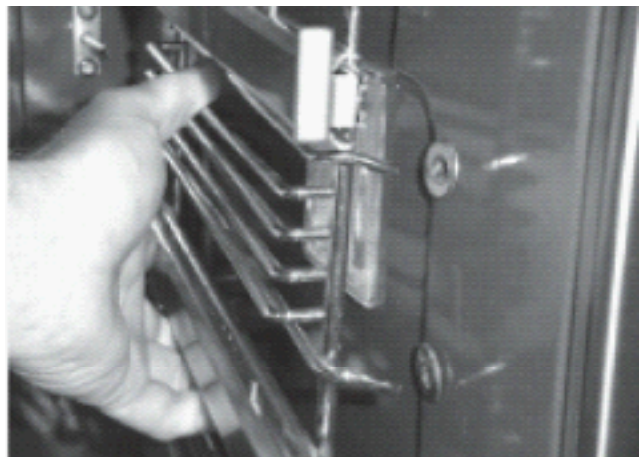

Figure 14

To remove the oven rack support for a self-clean cycle, support and lift front bottom of rack support to release front tabs. Then, rotate rack support up and out to release rear tabs. If the rack supports are not removed, the self-cleaning cycle won't start.

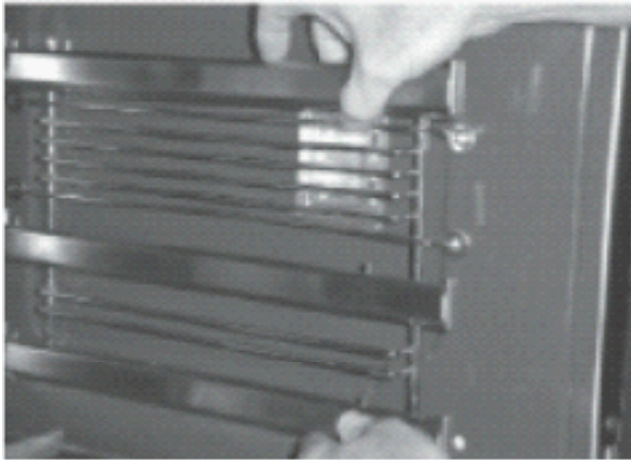

Figure 15

Removing and Replacing Oven Racks

ALWAYS ARRANGE OVEN RACKS WHEN THE OVEN IS COOL (PRIOR TO OPERATING THE OVEN).

Always use oven mitts when using the oven. **To remove an oven rack**, pull the rack forward. Lift up the rack off the oven rack glides. **To install an oven rack**, locate the two pinholes in the small plate at the front corner of the rack. Position the back of the rack on the rack glides and drop to pinholes over the pins on the rack glides.

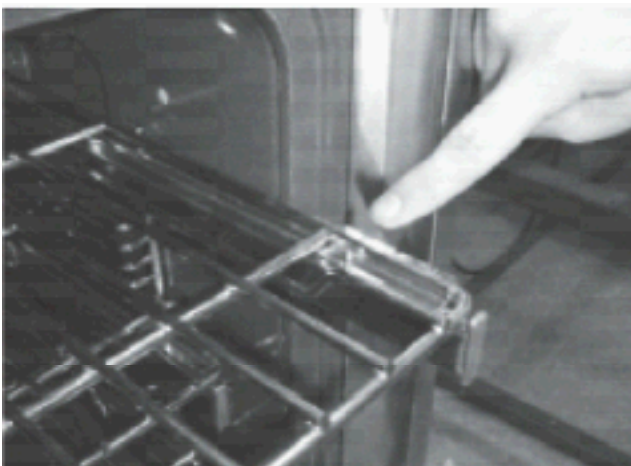

Figure 16

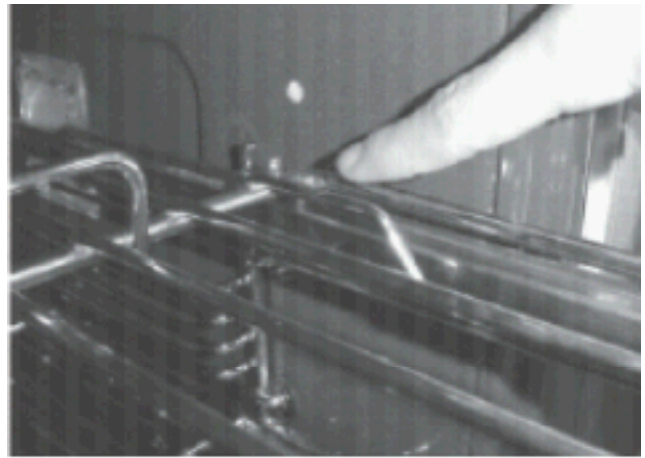

Figure 17

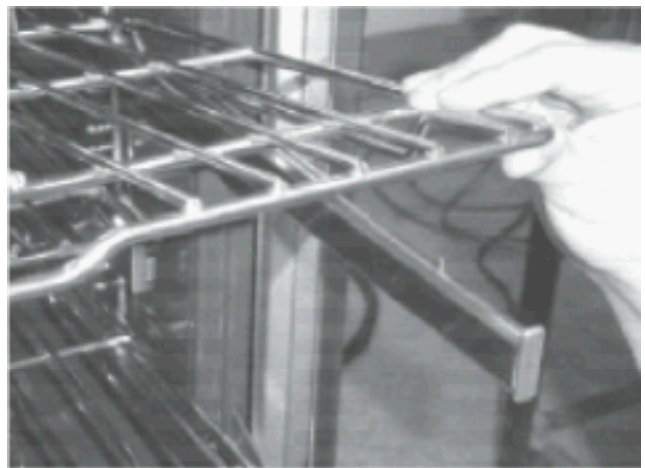

Figure 18

Arranging Oven Racks

ALWAYS ARRANGE OVEN RACKS WHEN THE OVEN IS COOL (PRIOR TO OPERATING THE OVEN). Three chrome-plated Smooth-GlideMR oven racks and one chrome plated conventional oven rack are provided with your range.

To bake on a single rack, place the rack in position 3.

To bake on 2 racks, place the racks in position 2 and 4. To bake on 3 racks, place the racks in position 1, 3, 5. (See figure 19).



Figure 19

RECOMMENDED RACK POSITIONS FOR BROILING, BAKING AND ROASTING

Food Rack	Position
Broiling meats, chicken or fish	3,4,5
Cookies, cakes, pies, muffins	2,3
Frozen pies, Angel Food cake, yeast breads, casseroles	2
Turkey, roast, ham	1

NOTE: Always use caution when removing food.

Baking Layer Cakes with 1 or 2 Oven Racks

For best results when baking cakes or cookies using 2 oven racks, place cookware on rack positions 2 and 4. (see figure 20).

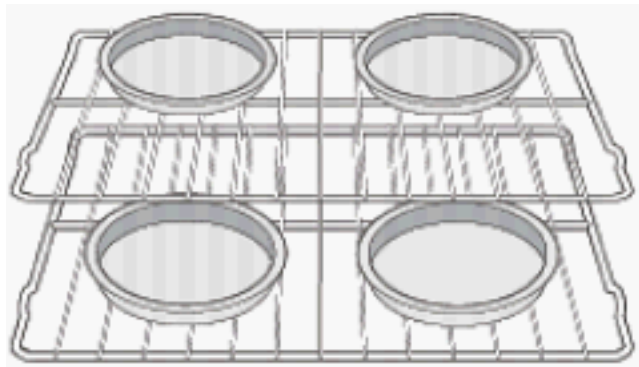

Figure 20

For best results when using a single oven rack, place cookware on rack position 3. (Fig. 21).

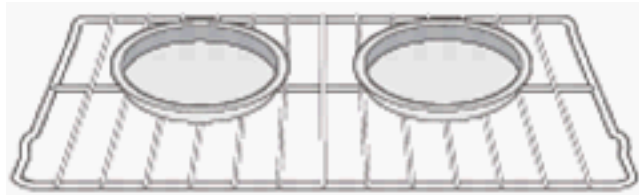

Figure 21

Air Circulation in the Oven

For best air circulation and baking results allow 2-4” (5-10cm) around the cookware for proper air circulation and be sure pans and cookware do not touch each other, the oven door, sides or back of the oven cavity. The hot air must be able to circulate around the pans and cookware in the oven for even heat to reach around the food.

Setting Oven Controls

SELECTOR KNOBS AND FUNCTIONS

Read the instructions carefully before using the oven. For satisfactory use of your oven, become familiar with the various functions of the oven as described below.



E30GF74GPS



E36GF75GPS



E36GF76GPS

OVEN FUNCTION

All oven functions are described below.

Standard Bake- With the Standard Bake function, the bottom bake burner provides conventional baking heat. Temperatures may be set from 170°F (77°C) to 500°F (260°C). Use Standard Bake for single rack baking or roasting.

Convection Cooking - With the Convection function, the convection fan in the rear of the oven circulates the heat from the bake burner, distributing the heat evenly throughout the oven cavity. Because of the evenly distributed heat, multiple rack cooking is possible. Convection cooking is faster than conventional cooking with some baked foods along with reduced temperatures. Most meats and poultry have up to 25% reduction in cook times.

Infrared Broil - The broil burner is located at the top of the oven. The burner heats the metal screen until it glows. The glowing screen produces the infrared heat, searing the outside of broiled foods and sealing in the juices. **Broiling is performed with the oven door closed.**

BAKING

This cooking mode is for normal baking, roasting or warming. The temperature control knob can be set at any temperature from 170°F (77°C) to 500°F (260°C).

To set the Bake temperature to 350°F:

1. Arrange interior oven racks to desired positions.
2. Turn "Oven" selector knob to 350°F.
3. The oven indicator light will turn on, and the oven will begin to preheat. Once the oven temperature reaches 350°F the oven indicator light will turn off. The oven indicator light will cycle on and off until the Bake selector knob is turned to the "OFF" position.

To change the baking temperature (example 350°F to 425°F):

- 1 After the oven is already been set at 350°F, and the oven temperature needs to be changed to 425°F, turn the temperature control knob to 425°F. The oven indicator light will turn off when the oven temperature reaches 425°F.



WARNING

NEVER cover any slots, holes or passages in the oven bottom or cover an entire rack with materials such as aluminum foil. Doing so blocks air flow through the oven and may cause carbon monoxide poisoning. Aluminum foil linings may trap heat, causing a fire hazard.

OVEN VENT

Do not block the duct at the rear of the range when cooking in the oven. It is important that the flow of hot air from the oven and fresh air into the oven burner never be interrupted. Avoid touching the vent openings or nearby surfaces during oven or broiler operation – they may become hot.







WARNING

FOOD SAFETY - According the United States Department of Agriculture: Do not hold foods between 40°F to 140°F more than 2 hours. Cooking raw foods below 275°F is not recommended.

BAKING PROBLEMS

For best cooking results, preheat the oven before baking cookies, breads, cakes, pies or pastries, etc. There is no need to preheat the oven for roasting meats and poultry, or baking casseroles. The cooking times and temperatures needed to bake a product may vary slightly from your previous appliance.

Baking Problems and Solutions Chart

Baking Problems	Causes	Solutions
<p>Cookies and biscuits burned on the bottom.</p> 	<ul style="list-style-type: none"> • Cookies and biscuits put into the oven before the preheating time is completed. • Oven rack overcrowded or rack position to low. • Dark pan absorbs heat too fast. 	<ul style="list-style-type: none"> • Allow oven to preheat to the selected temperature before placing food in the oven. • Choose pan sizes that will permit (2" to 4") of air space on all sides when placed in the oven. • Use a medium weight aluminum baking sheet.
<p>Cakes too dark on top or bottom.</p> 	<ul style="list-style-type: none"> • Cakes put into oven before preheating time is completed. • Rack position too high or low. • Oven too hot. 	<ul style="list-style-type: none"> • Allow oven to preheat to the selected temperature before placing food in the oven. • Use proper rack position for baking needs. • Set oven temperature 25° F. lower than recommended.
<p>Cakes not done in the center.</p> 	<ul style="list-style-type: none"> • Oven too hot. • Incorrect pan size. • Pan not centered in oven 	<ul style="list-style-type: none"> • Set oven temperature 25° F. lower than recommended. • Used pan size suggested in recipe. • Used proper rack position and place pan so there is 2" to 4" of space on all sides of pan.
<p>Cakes not level.</p> 	<ul style="list-style-type: none"> • Oven not level. • Pan too close to oven wall or rack overcrowded. • Pan warped. 	<ul style="list-style-type: none"> • Place a measuring cup filled with water on the center of the oven rack. If the water level is uneven, refer to the installation instructions for leveling the range. • Be sure to allow 2" to 4" of clearance on all sides of each pan in the oven. • Do not use pans that are dented or warped.
<p>Foods not done when cooking time is up.</p> 	<ul style="list-style-type: none"> • Oven too cool. • Oven overcrowded. • Oven door opened too frequently. 	<ul style="list-style-type: none"> • Set oven temperature 25° F. higher than suggested and bake for recommended time. • Be sure to remove all pans from the oven except the ones to be used for baking. • Open oven door only after shortest recommended baking time.

Cooking Instructions

CONVECTION BAKING AND ROASTING

As a general rule, convection baking will allow preparation of most foods at reduced temperatures for shorter periods of time, while allowing superior results.

Typically, you can reduce the standard bake temperature the recipe recommends by 25°F (approx. 15°C). In addition, the recipe's recommended cook time can also be reduced 10% to 25%.

In the convection mode, the convection fan located in the rear of the oven cavity draws air from the oven chamber, and directs the heated air back into the chamber through the convection baffle. The baffle distributes the air evenly to ensure uniform results. Temperatures may be set from 170°F (77°C) to 500°F (260°C).

General Convection Instructions for Baking

- 1 When baking with the convection mode, start by decreasing your recipe's recommended cooking temperature by 25°F. Then, decrease your recipe's recommended cooking time by 25%. Time reductions will vary depending on the amount and type of food to be cooked.
- 2 Baking pans with no sides or very low sides should be used to bake on so heated air can be allowed to circulate around the food. Food baked on a pan with a darker finish will cook faster.

To set oven for baking with the convection mode, using a recipe requiring 350°F:

1. Arrange oven racks to desired position.
2. Turn the "Oven" selector knob to 325°F.
3. The oven indicator light will turn on, and the oven will begin to preheat. Once the oven temperature reaches 325°F the oven indicator light will turn off.
4. Press fan switch to the "On" position to begin convection cooking.

The oven indicator light will cycle on and off until the "Oven" selector knob is turned to the "OFF" position.

To change the Convection Bake temperature (example 325°F to 400°F):

- 1 After the oven has already been set to 325°F, and the oven temperature needs to be changed to 400°F, turn the Bake selector knob to 400°F. When the oven temperature reaches 400°F, the oven indicator light will turn off.

Baking Problems

CONVECTION BAKING AND ROASTING

To roast meats and poultry, the Convection mode is recommended to produce meats and poultry that are deliciously seared on the outside and succulently juicy on the inside in record time.

Foods that are exceptional when prepared with the Convection mode include: beef, pork, ham, lamb, chicken, turkey and Cornish hens.

When preparing meats for convection cooking, use the broiler pan and insert which comes with your range. Placing the food on the top of the pan insert will allow the heat to circulate around the food.

General Convection Instructions for Roasting

1. When roasting with the convection mode, set the oven temperature to your recipe's recommended cooking temperature. Start by decreasing your recipe's recommended cooking time by 25%, adding more cooking time if needed for your desired Time reductions will vary depending on the size and type of food to be cooked.
2. When roasting meats, always roast meats fat side up. Always use a pan that fits the size of the food being prepared. In most cases, the broiler pan and insert can be used. No basting is required when the fat side is up. Do not add water to the pan. It will cause a steamed effect. Roasting is a dry heat process.
3. Poultry should be placed breast side up, in a shallow pan that fits the size of the food. Again, your broiler pan and insert accompanying the range can be used. Poultry can be basted with butter, margarine or oil before and during roasting.
4. When roasting with the Convection mode, pans with tall sides are not recommended. They

interfere with the circulation of heated air over the food.

5. When using a meat thermometer, insert the probe half way into the center of the thickest portion of the meat. (For poultry, insert the thermometer probe between the body and leg into the thickest part of the inner thigh) To ensure an accurate reading, the tip of the probe should not touch the bone, fat or gristle. Check the meat thermometer 2/3 of the way through the recommended roasting time. After reading the meat thermometer once, insert it 1/2 inch further, then take a second reading. If second reading registers lower than the first, continue cooking the meat.
6. Remove meats from the oven when the thermometer registers 5°F to 10°F below the desired temperature. The meat will continue to cook after removal. Allow 15 to 20 minutes after roasting in order to make carving easier.
7. The Convection mode is not recommended for meats or poultry cooked with a cooking bag, foil tent or other cover. Food cooked with these methods will produce better results when using the standard Bake mode.
8. Roasting times will always vary according to the size, shape and quality of meats and poultry. Less tender cuts of meat are best prepared in the standard Bake mode and may require moist cooking techniques. Follow your favorite cookbook recipes.
9. Reduce splatter by lining the bottom of the roasting pan with lightly crushed aluminum foil.

To set oven for roasting with the convection mode, using a recipe requiring 350°F:

1. Arrange oven racks to desired position.
2. Turn "Oven" selector knob to 350°F.
3. The oven indicator light will turn on, and the oven will begin to heat. Once the oven temperature reaches 350°F the oven indicator light will turn off.
4. Press fan switch to the "On" position to begin convection cooking. Once the oven reaches 350°F, the light will turn off. The light will cycle on and off until the "Oven" Selector Knob is turned

to the "OFF" position.

To change the Convection mode temperature (example changing 350°F a 425°F):

After the oven has already been set at 350°F, and the oven temperature needs to be changed to 425°F, turn the "Bake" control knob to 425°F. When the oven temperature reaches 425°F, the oven indicator light will turn off.

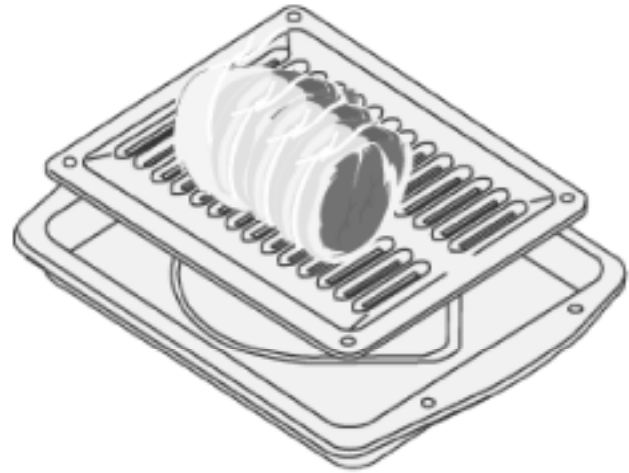

BROILING

Broiling is a method of cooking tender cuts of meat directly under the infrared broiler in the oven. Broiling in the oven is accomplished with the oven door closed. It is normal and necessary for some smoke to be present to give the food a broiled flavor.

Preheating

Preheating is suggested when searing rare steaks (Remove the broiler pan before preheating with the infrared broiler. Foods will stick on hot metal). To preheat, turn the "Oven" selector knob to the "Broil" position. Wait for the burner to become hot, usually about 2 minutes. Preheating is not necessary when broiling meat well-done.

To Broil

Broil one side until the food is browned; turn and cook on the second side. Season and serve. Always pull the rack out to the "stop" position before turning or removing food.

Setting Broil

The "Oven" selector knob controls the Broil feature. When broiling, heat radiates downward from the oven broiler for even coverage. The Broil feature temperature is 500°F (260°C).

The broil pan and insert used together allow dripping grease to drain and be kept away from the high heat of the oven broiler. **DO NOT** use the broil pan without the insert. **DO NOT cover the broil pan insert with foil.** The exposed grease could catch fire.

To set the oven to Broil:

1. Place the broiler pan insert on the broiler pan. Then place the food on the broiler pan insert. **DO NOT** use the broiler pan without the insert. **DO NOT** cover the broiler insert with foil. The exposed grease could catch fire.
2. Arrange the interior oven rack and place the broiler pan on rack. Be sure to center the broiler pan is directly under the broil burner. If preheating the broil burner first, position the broiler pan with food after

3. Turn selector knob to Broil.

The oven light will remain on until the selector knob is turned to the off position or the temperature control knob is turned to the off position.

BROILING TIPS

The broiling pan and its insert allow dripping grease to drain and be kept away from the high heat of the broiler.

NOTE

DO NOT use the broiler pan without its insert. DO NOT cover the broiler pan insert with foil. The exposed grease could ignite.

Broiling Times

Use the following table for approximate broiling times. Increase or decrease broiling times, or move the broiling pan to a different rack position to suit for doneness. If the food you are broiling is not listed in the table, follow the instructions provided in your cookbook and watch the time closely.

Oven Broiling Recommendations.

Food Item	Rack Position	Knob Setting	Cook Time		Doneness
			1st side	2nd side	
Steak 1" thick	4 or 5	"BROIL"	4:00	3:00	Rare
	4 or 5	"BROIL"	5:00	4:00	Medium
Pork Chops 3/4" thick	4 or 5	"BROIL"	6:00	4:00	Well
Chicken- Bone In	3	"BROIL"	20:00	10:00	Well
Chicken - Boneless	4 or 5	"BROIL"	6:00	4:00	Well
Fish	4 or 5	"BROIL"	13:00	n/d	Well
Shrimp	3	"BROIL"	5:00	n/d	Well
Hamburger 1" thick	3 or 4	"BROIL"	10:00	8:00	Well



CAUTION

Should an oven fire occur, turn off the oven. If the fire continues, throw baking soda on the exposed fire or use fire extinguisher. **DO NOT** put water or flour on the fire. Flour may be explosive.

Broiler Clean-Up Tips:

To make cleaning easier, line the bottom of the broiler pan with aluminum foil. DO NOT cover the broiler pan insert with foil.

To prevent grease from baking on, remove the broiler pan from the oven as soon as cooking is completed. Use hot pads because the broiler pan will be extremely hot. Pour off grease. Soak the pan in HOT, soapy water. The broiler pan and insert can be washed in your dishwasher.

Clean the broiler pan as soon as possible after each use. If necessary, use soap-filled steel wool pads. Heavy scouring may scratch the broiler pan insert.

Care and Cleaning

OVEN LIGHT

Your new range has halogen oven lights to enhance the view into the oven. The light assembly consists of a removable lens cover and 50-watt 120VAC halogen bulb, as well as a light fixture housing. Light bulb replacement is considered to be a homeowner maintenance operation.

To replace the light bulb:

1. Turn off the power at the main power supply.
2. Remove rack supports in order to access light housing.
3. Remove the lens cover from the housing by pulling straight out, using a flathead screwdriver or putty knife to carefully pry loose the lens, if needed.
4. Replace halogen bulb, taking care not to touch the bulb. If you touch the halogen bulb with your finger, body oils can shorten the life of the bulb.

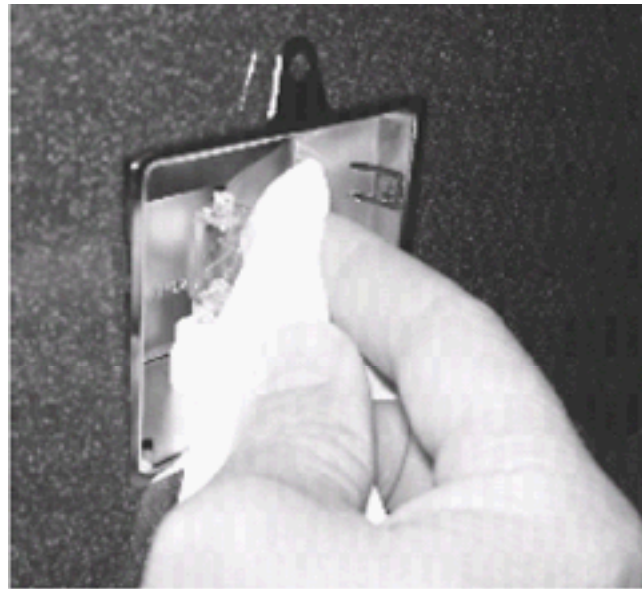

5. To replace glass shield, reverse the procedure.

Remove bulb



Replace glass shield after replacing bulb

Be sure the range is unplugged and all parts are COOL before replacing oven light.

CLEANING TIPS FOR RANGE OVEN

Porcelain Enamel Oven

The oven interior is porcelain on steel and it is safe to clean using oven cleaners.

General Cleaning

Remove soils using hot, soapy water. Do not allow food spills with a high sugar or acid content (such as milk, tomatoes, sauerkraut, fruit juices or pie filling) to remain on the surface as they may cause a dull spot even after cleaning.

To Remove Heavy Soil:

1. Allow a dish of ammonia to sit in the oven overnight or for several hours with the oven door closed. Clean softened dirt spots using hot, soapy water. Rinse well with water and a clean cloth.
2. If soil remains, use a soap-filled scouring pad or a nonabrasive cleaner. If necessary, use an oven cleaner following manufacturer's instructions. DO NOT mix ammonia with other cleaners.
3. Clean any soil from the oven frame, the door liner outside the oven door gasket and the small area at the front center of the oven bottom. Clean with hot, soapy water. Rinse well using clean water and a cloth.

Adhere to the following precautions when using oven cleaners:

1. DO NOT spray cleaner on the electrical controls or switches because it could cause a short circuit and result in sparking or fire.
2. DO NOT allow a film from the cleaner to build up on the temperature sensing bulb; it could cause the oven to heat improperly. (The bulb is located on the left interior wall of the oven.) Carefully wipe the bulb clean after each oven cleaning, being careful not to move the bulb. A change in its position could affect how the oven bakes. Avoid bending the bulb and capillary tube.
3. DO NOT spray any cleaner on the oven door trim or gasket, broiler drawer glides, handles or any exterior surfaces of the range, plastic or painted surfaces. The cleaner can damage these surfaces.

Cleaning the Oven Bottom

The oven bottom is porcelain enamel and can be removed for easier cleaning. Clean using hot, soapy

water, a mild abrasive cleanser, a soap-filled abrasive pad or oven cleaner following manufacturer's instructions.

CLEANING TIPS FOR RANGE COOKTOP

No maintenance, other than the **Care and Cleaning** identified in this **Use & Care Manual**, should be attempted by the owner/operator. All other maintenance and service must be performed by a qualified appliance technician.

WARNING

To avoid electrical shock or burns, turn off all controls and ensure the cooktop is cool before cleaning.

IMPORTANT

Do not use harsh or abrasive cleaning agents, waxes, polishes, or commercial cooktop cleaners to clean the cooktop.

Read and follow the **Care and Cleaning** instructions to ensure that proper cooktop operation and appearance will be maintained throughout the lifetime of the product. Several materials and finishes are used in the cooktop. Each material and finish must be properly cleaned according to the following recommendations. Failure to follow these recommendations may result in permanent damage to the cooktop.

Proper cleaning is necessary to maintain cooktop performance and appearance, while also ensuring safe operation. The cleaning effort necessary to maintain the cooktop varies according to the type and amount of cooking. For example, more frequent cleaning is required if the cooktop is used often for frying or other high temperature operations.

Clean the cooktop thoroughly prior to operating it the first time. For initial and everyday cleaning, use a soft cloth or sponge lightly dampened with a solution of warm water and hand dishwashing liquid to clean all components.

WARNING

- **Before cleaning the cooktop, ensure that all burners are turned off and that all components are cool enough to safely touch.**

- **After cleaning, reassemble all components before attempting to operate the cooktop.**

Recommendations for cleaning and care of specific cooktop components are summarized below:

IMPORTANT

The grates and burner caps, unlike other porcelain enamel appliances in your home, are exposed to extremely high temperatures in a matter of seconds. In addition to this extreme thermal shock, the grates are subjected to mechanical shock when utensils are placed on or slid across them. Finally, spillovers introduce foods with high acidity to all of the porcelain components. Due to these severe operating conditions, all porcelain enamel components on the cooktop will undergo an inevitable change in appearance with use. Meticulous care and cleaning will slow but not eliminate this natural and expected aging process.

Treating the porcelain components with care will slow the natural deterioration that takes place with cooktop use. Please follow these guidelines to keep the porcelain parts looking their best:

- 1 Do not use utensils having rough bottoms, as this can result in permanent damage to the top surfaces of the porcelainized grates.
- 2 Do not drop utensils onto the grates or drag heavy pots across the tops of the grates.
- 3 Set the grates into the cooktop gently. Do not drop the grates into place.
- 4 Use caution when cooking to avoid spills as much as possible. Porcelain is acid-resistant but not acid-proof, so some foods can cause permanent damage if allowed to remain on porcelain surfaces.

Daily cleaning of the grates, burner heads, burner base and burner caps is best accomplished with a soft cloth or sponge dampened in a solution of warm water and hand dishwashing liquid. Grates are dishwasher safe. Burner caps should not be cleaned in the dishwasher.

Stubborn stains may be removed by applying full-strength, all purpose cleaning sprays. (If you are unable to locate these cleaning compounds, please phone the Electrolux Customer Service Department for a referral.)

Mildly abrasive cleaners or applicators, such as soap-filled steel wool pads, may be used with extreme care on occasion to remove the most serious stains. **Exercise caution – extensive use of abrasives will eventually damage the porcelain enamel surface.**

CLEANING STAINLESS STEEL SURFACES

Clean these surfaces with the provided Stainless Steel Cleaner. Rinse and dry with a soft lint-free cloth.

IMPORTANT

If commercially available stainless steel cleaners are used, it is important to read the labels for chlorine compounds. Chlorine is a corrosive substance. If these compounds are present, rinse thoroughly and dry with a soft lint-free cloth.

Always wipe stainless steel surfaces with the grain.

CLEANING PORCELAIN GRATES

Clean the porcelain grates with a solution of mild detergent and hot water. Rinse with a soft cloth. Do not use abrasives or commercial oven cleaners.

Stubborn stains may be removed by washing the grates in a dishwasher, using normal dishwashing detergent.

IMPORTANT

Never use the cooktop surface as a cutting board.

Do not use abrasive cleaners or applicators on the cooktop.

Do not try to remove heavy spills with a sharp object such as a knife or metal spatula. Sharp objects may scratch the cooktop.

A small amount of baby oil may be applied to stainless steel tops to restore the lustre.

CLEANING KNOBS AND KNOB BEZELS

The control knobs provided with this cooktop are designed for ease of use and longevity. The “D” shaped design of the knob shaft ensures proper orientation when reinstalling the knob.

The knobs and knob bezels are made of a composite plastic. These components should be washed regularly in warm, soapy water. Hand dishwashing liquid is excellent for this task. Knobs should be removed by gently pulling them straight out and off of the valve shafts. Use caution to avoid introduction of moisture into the control panel behind the bezels. To replace knobs, align the “D-shaped” opening at the bottom of the knob with the “D-shaped” valve shaft, then carefully press the knob onto the valve.

CLEANING BURNER BASES

The base should be wiped clean using a soft cloth or sponge that has been lightly dampened with warm water and hand dishwashing liquid. Thoroughly clean and dry the igniters to prevent constant sparking of the reignition system. Refer to the **Cleaning the Burner Igniters** section for cleaning tips.

IMPORTANT

- **Turn the knobs to the “OFF” position prior to removing them from the valve stems.**
- **The cooktop should never be operated without the knobs in place.**
- **Do not soak the knobs in water or place them in the dishwasher.**
- **Do not expose the knobs to direct flame, hot utensils, or other sources of heat.**
- **Do not use abrasive or corrosive cleaners or applicators, as these could cause permanent damage.**

CLEANING BURNER HEADS OR BURNER CAPS

The burner heads spread the flame evenly around the burner perimeters. The burner heads must seat properly in the burner bases to enable proper cooktop operation.

To remove the burner head, first remove the grate, then lift off the burner cap. The burner head may then be removed from the burner base. Soak the burner ring in a warm solution of hand dishwashing liquid and water, then rinse well with clean water. Dry the burner thoroughly. The same cleaning instructions apply to the burner heads and burner caps.

Stubborn stains may be removed by applying a metal

polishing compound. (If you are unable to locate this type of polishing compound, please phone the Electrolux Customer Service Department for a referral.)

CLEANING THE BURNER IGNITERS

Under certain cooking or cleaning conditions, your cooktop igniters may become coated with or corroded by food deposits, splattered grease or cleaning agents.

This condition can cause erratic or continuous sparking. Keeping the igniters clean and dry will help to reduce this problem. To avoid unnecessary and costly service calls, the homeowner should perform periodic cleaning of the igniters.

To clean the igniters:

- 1 Be sure the burners are cool to the touch. Remove the grate, burner cap and burner heads.
- 2 Clean completely around the igniter, including over and under the edge of the metal cap and base. Use care while cleaning here. Parts of the igniter are porcelain and can be fragile.
- 3 DO NOT USE WATER when cleaning the igniters. If a liquid must be used to clean the igniter effectively, use only a small amount of rubbing alcohol.
- 4 After cleaning, reinstall the burner ring, burner cap and grate. Make sure the brass burner ring is properly seated into the burner base.
- 5 Test the burners. If erratic clicking is still present, make sure the igniter is completely dry.

GENERAL CLEANING

Cleaning Various Parts of Your Appliance

Before cleaning any part of your appliance, be sure all controls are turned OFF and the appliance is COOL. REMOVE SPILLOVERS AND HEAVY SOILINGS AS SOON AS POSSIBLE. REGULAR CLEANING WILL REDUCE THE NUMBER OF MAJOR CLEANINGS LATER.

Surfaces

How to Clean

Painted and Plastic

Body Parts and Decorative Trim.

Using a soft cloth, clean with mild dish detergent and water or a 50/50 solution of vinegar and water. Follow by rinsing the area with clean water; dry and polish with a soft cloth.

Glass cleaners may be used if sprayed on a soft cloth first. DO NOT spray liquids directly on the controls area. Do not use large amounts of water on the control panel - excess water on the control area may cause damage to the appliance.

Do not use other liquid cleaners, abrasive cleaners, scouring pads, or some paper towels - they will damage the finish

Control Panel.

Before cleaning the control panel, turn all controls OFF. Glass cleaners may be used if sprayed on a soft cloth first. DO NOT spray liquids directly on the control area. Wipe with a soft cloth or paper towel. DO NOT use abraivse cleaners or scouring pads. These can permanently damage the control panel surface.

Porcelain Enamel

Broiler Pan, Broiler Pan Insert and Cooktop Spill Tray.

Gentle scouring with a soapy scouring pad will remove most spots. Rinse with a 1:1 solution of clear water and ammonia. *If necessary*, cover difficult spots with an ammonia-soaked paper towel for 30 to 40 minutes. Rinse with clean water and a damp cloth, and then scrub with a soap filled scouring pad. Rinse and wipe dry with a clean cloth. Remove all cleaners, or the porcelain may become damaged during future heating.

Stainless Steel, Chrome

Decorative Trim, Oven Racks, Oven Rack Supports.

Clean with hot, soapy water and a dishcloth. Rinse with clean water and a cloth. Cover stubborn spots with an ammonia-soaked paper towel for 30 to 40 minutes. Rinse. Cleaners made especially for stainless steel is recommended. Be sure to rinse and remove the cleaners as bluish stains may occur during heating and cannot be removed.

Oven Racks and Rack Supports.

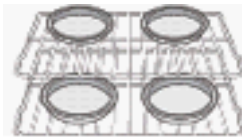

Oven racks and oven rack supports should be removed from the oven before cleaning. This will ensure thorough cleaning of the oven interior.

Oven Door.

To clean oven door, wash with hot, soapy water and a clean cloth. Do not immerse the door in water or clean the oven door gasket. DO NOT use abrasive cleaners on the inside of the oven door glass.

Oven Door Gasket.

The oven door gasket is located on the oven door and visible when the door is opened. This gasket is essential for a good seal. Care should be taken not to rub, damage or remove gasket.

Troubleshooting

Problem	Possible Causes	What to Do
Nothing works.	Oven is not connected to electrical power. Power supply is not energized.	Have oven connected to a properly sized electrical power supply by a qualified electrician. Have an electrician check power supply, including the house circuit breaker, wiring and fuses.
Top burners do not light or do not burn evenly.	Plug on range is not completely inserted in the electrical outlet.	Make sure the unit is properly connected to power supply.
Burner flames very large or yellow.	Burner bezel ports are clogged. Burner ports or burner caps are not positioned properly. Cooktop is being operated with the wrong type of gas. Regulator is not installed, is faulty, or is set for the wrong type of gas.	Clean burner bezel ring ports with straightened paper clip, needle or wire. Remove and carefully re-install burner bezel and caps. Ensure that the type of cooktop matches the natural gas supply. Check installation, replace regulator, or set regulator for proper gas supply.
Sparkling, but no flame ignition.	Gas shut-off valve is in "off" position.	Turn shut-off valve to "on" position.
Igniters spark continuously after flame ignition.	Power supply polarity is reversed. Igniters are wet or dirty.	Have polarity corrected. Dry or clean igniters.
Burner flame goes out at low setting.	Low gas supply pressure. Air intake holes around knobs are obstructed.	Contact gas company Remove obstruction.
Oven will not heat.	Oven settings are not correct.	Follow mode selection and clock settings as specified in OVEN OPERATION.
Foods over-cooked or under-cooked.	Incorrect cooking time, or temperature.	Adjust time, temperature or rack position.
"Cracking" or "popping" sound.	This is the sound of the metal heating and cooling.	This is normal.

APPLIANCE WARRANTY Your appliance is protected by this warranty

Sample warranty always refer to warranty with the product

In the USA your appliance is warranted by Electrolux home products North America. We authorize no person to change or add to our obligation under this warranty. Our obligation for service and parts under this warranty must be performed by us or an authorized Electrolux Home Products North America

	WARRANTY PERIOD	THROUGH OUR AUTHORIZED SERVICERS, WE WILL:	THE CONSUMER WILL BE RESPONSIBLE FOR:
FULL ONE-YEAR WARRANTY	One year from original purchase date	Pay all costs for repairing or replacing any part of this appliance, which proves to be defective in material or workmanship.	Cost of service calls that are listed under normal responsibility of the consumer.
LIMITED WARRANTY (Applicable to the state of Alaska)	Timed periods listed above.	All of these provisions of the full and limited warranties above and exclusions listed below apply.	Cost of the technicians travel to the home at any cost for pickup and delivery of appliance required because of service.

***NORMAL RESPONSIBILITIES OF THE CONSUMER** This warranty applies only to products in ordinary household use, and the consumer is responsible for the items listed below:

1. Proper use of the appliance in accordance with instructions provided with the product.
2. Proper installation by an authorized service or in accordance with instructions provided with the appliance in accordance with all local plumbing, electrical and/or gas codes
3. Proper connection to a grounded power supply of sufficient voltage, replacement of blown fuses, repair of loose connections or defects in the house wiring.
4. Expenses for making the appliance accessible for servicing, such as removing trim, cupboards, shelves, etc, which are not a part of the appliance when it was shipped from the factory.
5. Damages to finish after installation.
6. Replacement of light bulbs, and/or fluorescent tubes (on models with these features).

EXCLUSIONS

This warranty does not cover the following:

1. CONSEQUENTIAL OR INCIDENTAL DAMAGES SUCH AS A PROPERTY DAMAGE, AND INCIDENTAL EXPENSES RESULTING FROM ANY BREACH OF THIS WRITTEN OR ANY IMPLIED WARRANTY.
Note: Some states do not allow the exclusion or limitation of incidental or consequential damages, so this limitation or exclusion may not apply to you.
2. Service calls, which do not involve malfunction or defects in workmanship or material or for appliances not in ordinary household use. The consumer shall pay for such service calls.
3. Damages caused by service performed by servicers, other than Electrolux Home Products North America or its authorized servicers; use of parts other than genuine Electrolux Home Products parts; obtained from persons other than such servicers; or external causes such as abuse, misuse, inadequate power supply or acts of God.
4. Products with original service numbers that have been removed or altered and cannot be readily determined

IF YOU NEED SERVICE

Keep your bill of sale, delivery slip, or some other appropriate payment record. The date on the bill establishes the warranty should service be required. If service is performed, it is in your best interest to obtain and keep all receipts. This written warranty gives you specific legal rights. You may also have other rights from state to state. Service under this warranty must be obtained by contacting Electrolux Home Products

USA
1-800-944-9044
Electrolux Home
Products North
America
P.O. Box 212378
Augusta, GA. 30917

Canada
1-866-294-9911
Electrolux Home
Products North
America
802 boul. L'Ange-Gardien
L'Assomotion, Quebec

This warranty only applies in the 50 states of the USA, Puerto Rico, and Canada. Products features and specifications as described or illustrated are subject to change without notice. All warranties are made by Electrolux Home Products of North America, a division of White consolidated industries, Inc. In Canada your appliance is warranted by Electrolux, Canada, corp.

SECTION B - INSTALLATION INSTRUCTIONS

READ AND SAVE THESE INSTRUCTIONS

NOTE

Installer: Leave instructions with owner. **Owner:** Read your range Use & Care guide. It contains important safety information for operating this appliance. It also has many suggestions for getting the best results from your appliance.

Read all instructions before installing the range.

For your safety, please read and observe all safety instructions. This guide will help you anticipate all installations connections.

QUESTIONS

For toll-free telephone support in the U.S. and Canada: **1-877- 4ELECTROLUX (1-877-435-3287)**

For online support and Internet product information: **www.electroluxusa.com**

Safety

IMPORTANT SAFETY INSTRUCTIONS

Definitions



This is the safety alert symbol. It is used to alert you to potential personal injury hazards. Obey all safety messages that follow this symbol to avoid possible injury or death.



WARNING

WARNING indicates a potentially hazardous situation which, if not avoided, could result in death or serious injury.



CAUTION

CAUTION indicates a potentially hazardous situation which, if not avoided, may result in minor or moderate injury.

CAUTION

CAUTION used without the safety alert symbol indicates a potentially hazardous situation which, if not avoided, may result in property damage.

IMPORTANT

Indicates installation, operation or maintenance information which is important but not hazard related.

SAFETY PRECAUTIONS



WARNING

- **Read all instructions before using the appliance, service, or maintenance can cause personal injury or property damage. Refer to these instructions and the accompanying Use & Care Manual. For assistance or additional information, consult a qualified installer, service agency, manufacturer (dealer), or the gas supplier.**
- **For your safety:**
 - **Do not obstruct the flow of combustion and ventilation air to the unit.**
 - **Keep appliance area clear and free from combustible material, gasoline and other flammable vapors and liquids.**
 - **Do not use or attempt to use this appliance in the event of a power failure.**
- **This unit is designed as a cooking appliance. Never use it for warming or heating a room.**
- **This appliance must be installed with the gas pressure regulator supplied with it.**
- **Disconnect the electrical supply before installing or servicing the appliance.**
- **This appliance must be grounded. Connect only to a properly grounded electrical supply. Refer to “Electrical Requirements”.**
- **Install or locate this appliance only in accordance with these installation instructions.**
- **Use this appliance only for its intended use as described in this manual. Do not use corrosive chemicals or vapors in this**

appliance. This type of appliance is not designed for industrial or laboratory use.

- As with any appliance, close supervision is necessary when used by children.
- Do not operate this appliance if it has a damaged electrical cord, plug, conduit or wires, if it is not working properly, or if it has been damaged or dropped.
- This appliance should be serviced only by qualified service personnel.
- Some products, such as whole eggs, and sealed containers, such as closed glass jars, may explode and should not be heated on this cooktop.



WARNING

- Based on safety considerations, the top burner flame should be adjusted so it does not extend beyond the edge of the cooking utensil.
- If the information in this manual is not followed exactly, a fire or explosion may result causing property damage, personal injury, or death.
- What to do if you smell gas:
 - Do not try to light any appliance.
 - Do not touch any electrical switch, do not use any phone in your building.
 - Immediately call the gas supplier from a neighbor's phone.

- Follow the gas supplier's instructions.
- If you cannot reach your gas supplier, call the fire department.
- For your safety:
 - Do not store or use gasoline or other flammable vapors and liquids in the vicinity of this or any other appliance.
- Installation of this appliance must be performed by a qualified installer, service agency or the gas supplier. Contact the nearest Electrolux Authorized Servicer, call 1-877-435-3287, or contact us on the internet at www.electroluxusa.com.

Preparing for Installation

VERIFY PACKAGE CONTENTS

- Literature Pack
- Anti-Tip Bracket
- Burner Grate Pack
- Burner Rings
- Wok Ring
- Oven Racks
- Griddle (some models)
- Simmer Plate
- Broiler Pan/Insert
- Stainless Steel Cleaner
- Burner Caps

GAS AND ELECTRIC REQUIREMENT TABLE

NOTE

This range is shipped from the factory pre-set for use with natural gas. For LP conversion see the accompanying LP Conversion Kit. The electrical information in the table is also located on the serial number label on the range.

Model No.	Electrical Circuit	Total Connected	Gas Type	Manifold Pressure Water Column Inches	Minimum Gas Supply Water Column Inches
E30EF74GPS	120V 60Hz	5A	Natural	5"	6"
E30GF75GPS	120V 60Hz	8A	Natural	5"	6"
E36GF76GPS	120V 60Hz	5A	Natural	5"	6"

ELECTRICAL POWER SUPPLY REQUIREMENTS

It is the owner's responsibility to ensure that the electrical connection of this appliance is performed by a qualified electrician. The electrical installation, including minimum supply wire size and grounding, must be in accordance with the National Electric Code ANSI/NFPA 70-1993* (or latest revision) and local codes and ordinances. In Canada, electrical grounding must be in accordance with the current CSA C22.1 Canadian Electrical Code Part 1 and/or local codes.

*A copy of the standard must be obtained from:
National Fire Protection Association
1 Batterymarch Park
Quincy, Massachusetts 02269-9101

The correct voltage, frequency, and amperage must be supplied to the appliance from a separate, grounded, circuit that is protected by a properly sized circuit breaker or time delay fuse.



WARNING

If the gas or electric service provided does not meet the product specifications, do not proceed with the installation. Call the selling dealer, the gas supplier, or a licensed electrician.

NOTES

The power supply must be properly grounded. Improper grounding will result in continuous sparking of the electrodes, even after flame ignition.

If there is any doubt as to whether the power supply is properly polarized or grounded, have it checked by a qualified electrician.

Use 120V, 60Hz, and properly grounded branch circuit protected by a 15-amp or 20-amp circuit breaker or time delay fuse.

GAS AND ELECTRICAL ROUGH-IN

Locations

A manual shut valve must be installed in the gas piping, external to the appliance, for the purpose of turning on or shutting off gas to the appliance. Place the location of the range and the gas supply to allow access to the valve when the unit is installed. Access to the remote circuit breaker panel/fuse box, with the range in place, must also be allowed for in the installation. Any openings in the wall behind the appliance and in the floor under the appliance must be sealed. Both the gas supply piping and shut-off valve, and the electrical junction box/receptacle must be located so they do not interfere with the range when it is installed. In addition, the junction box must be located so the range can be removed

for service when the conduit supplied with the unit is attached to the junction box. Do not lengthen the conduit or wiring provided with the range.

NOTES

The areas shown in the illustrations, denote the location of the gas stub and the electrical junction box/receptacle. These are suggested locations. For replacement purposes, the location of the existing utilities may be utilized provided that they do not interfere with the sides or rear of the range. If installing the gas valve behind the range, verify that local building codes will permit this.

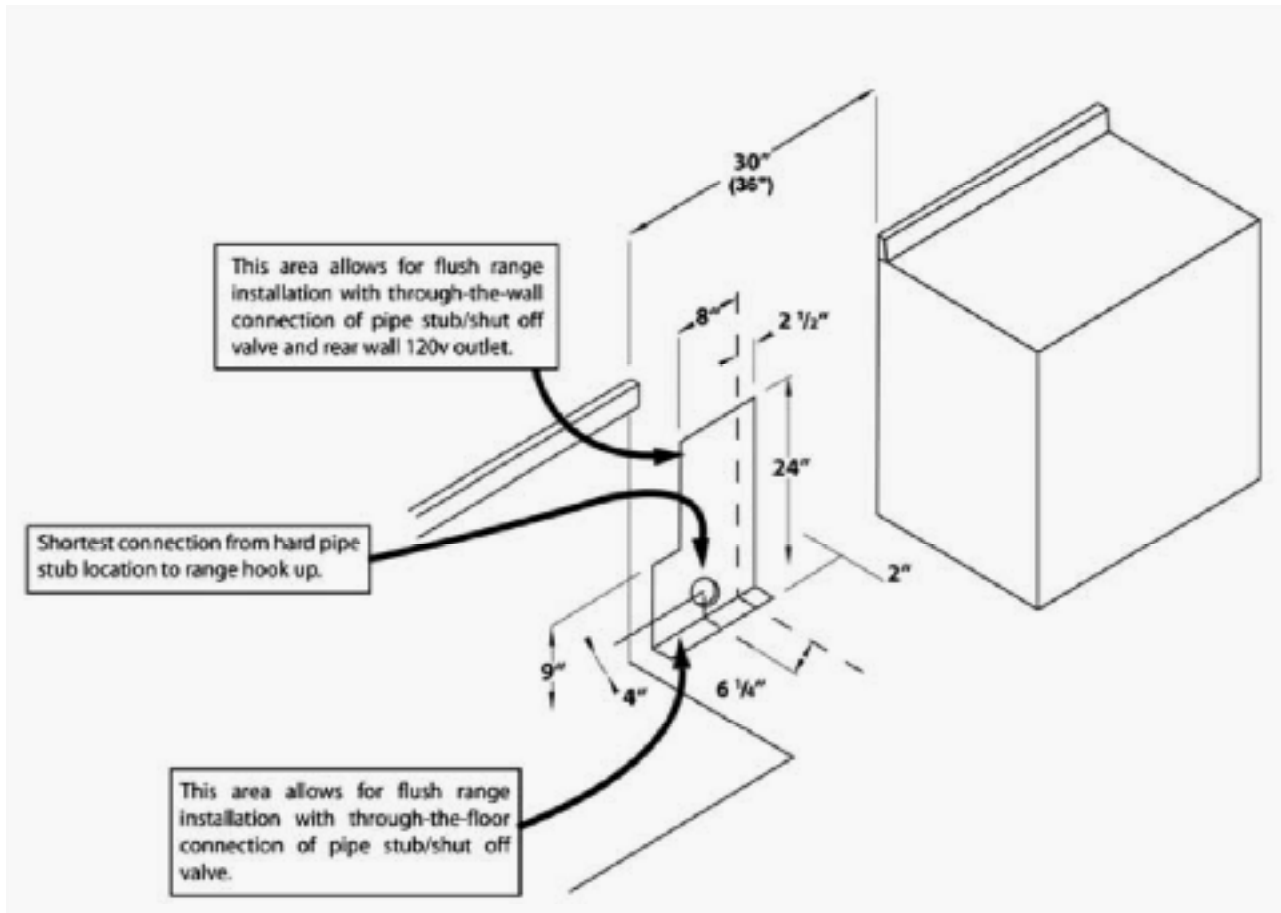

CABINET AND COUNTERTOP PREPARATION

Check your local building codes for the proper method of installation. In the absence of local codes, this appliance should be installed in accordance with the National Fuel Gas Code ANSI Z223.1/NFPA 54. In Canada, installation must conform to current Natural Gas Installation Code, CAN1-1.1-M and the local codes where applicable. This range has been design-certified according to ANSI Z21.1b-2003, latest edition. Be certain that the appliance being installed is correct for the gas service being provided. Refer to the rating label located on the kick panel and/or the table in this manual for gas supply requirements.

All dimensions shown are based on standard American cabinets, 36 inches (914mm) high at the finished countertop by 24 inches (610mm) deep, with a 25 inch (635mm) overall countertop depth. When installing the range into nonstandard cabinets, minimum clearances shown in the diagrams in this manual must be maintained.

Carefully check the location where the range is to be installed. For best performance, the range should be placed away from drafts that may be caused by doors, windows and HVAC outlets.

NOTES

- **If cabinet storage space is to be provided directly above the range, the risk of personal injury may be reduced by installing a ventilating hood that projects horizontally a minimum of 5 inches beyond the face of the cabinets.**
- **The range may be installed flush to the rear wall. We recommend installing a noncombustible material on the rear wall above the range and up to the vent hood. It is not necessary to install noncombustible materials behind the range below the countertop height.**
- **The minimum distance from the sides of the range above the countertop to combustible side walls must be at least 10 inches.**
- **All models are delivered with a 3.5" backguard from the factory. A 9" backguard is available on the E36GF75GPS AND E36GF76GPS as options.**

- **Utilities may be located: In the lower left corner of the adjacent right cabinet. (Refer to Figure 2)**

IMPORTANT

- **Contact your local building department to verify compliance with local code interpretation.**

GENERAL DIMENSIONS

Plan the installation so that the electrical connection, gas shut-off valve, and pressure regulator are accessible from the front of the cabinet.

Fig 2

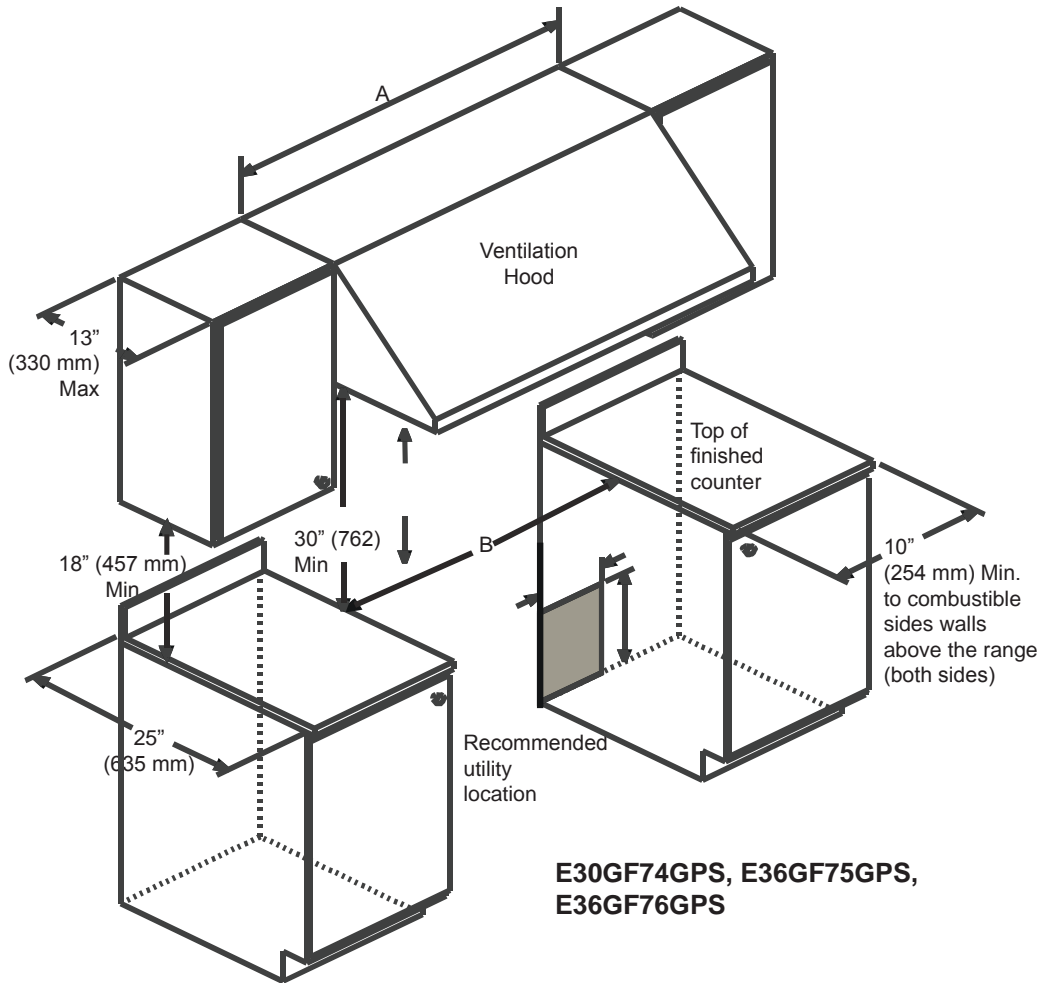

Cutout Dimensions		
Model	"A"	"B"
E30GF74 Series	30" (762 mm) Minimum Recommended	30 1/16" (764mm)
E36GF75 Series	36" (914) Minimum Recommended	36 1/16" (916 mm)
E36GF76 Series	36" (914) Minimum Recommended	36 1/16" (916 mm)

GENERAL DIMENSIONS

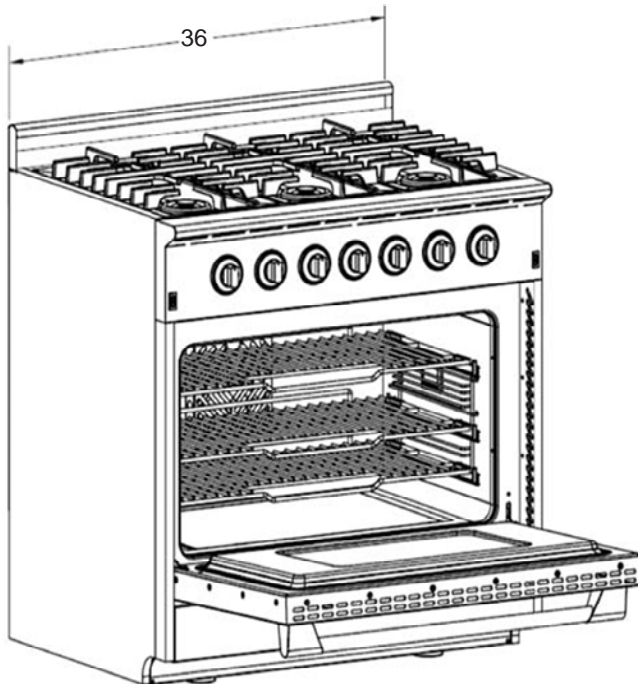
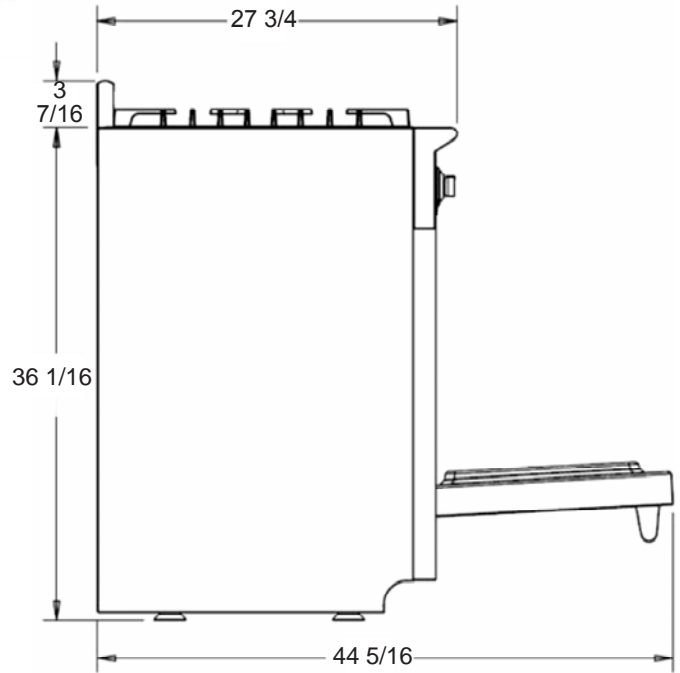
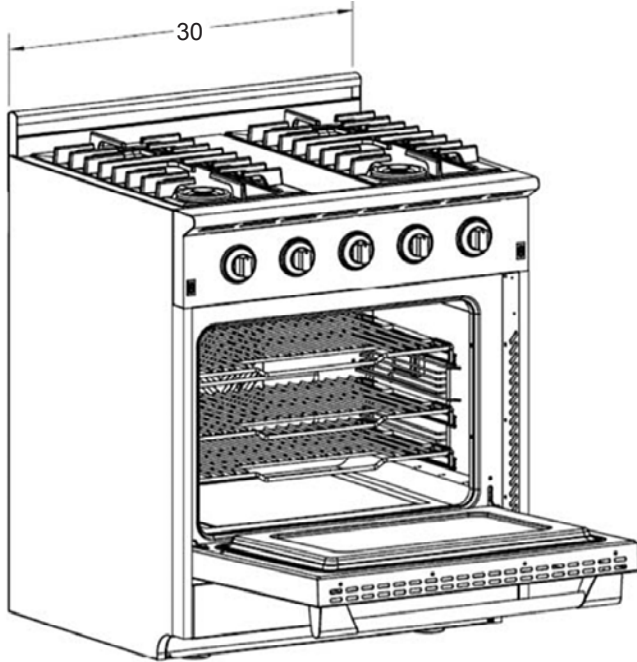

WOOD/COMPOSITE OVERLAY INSTALLATION

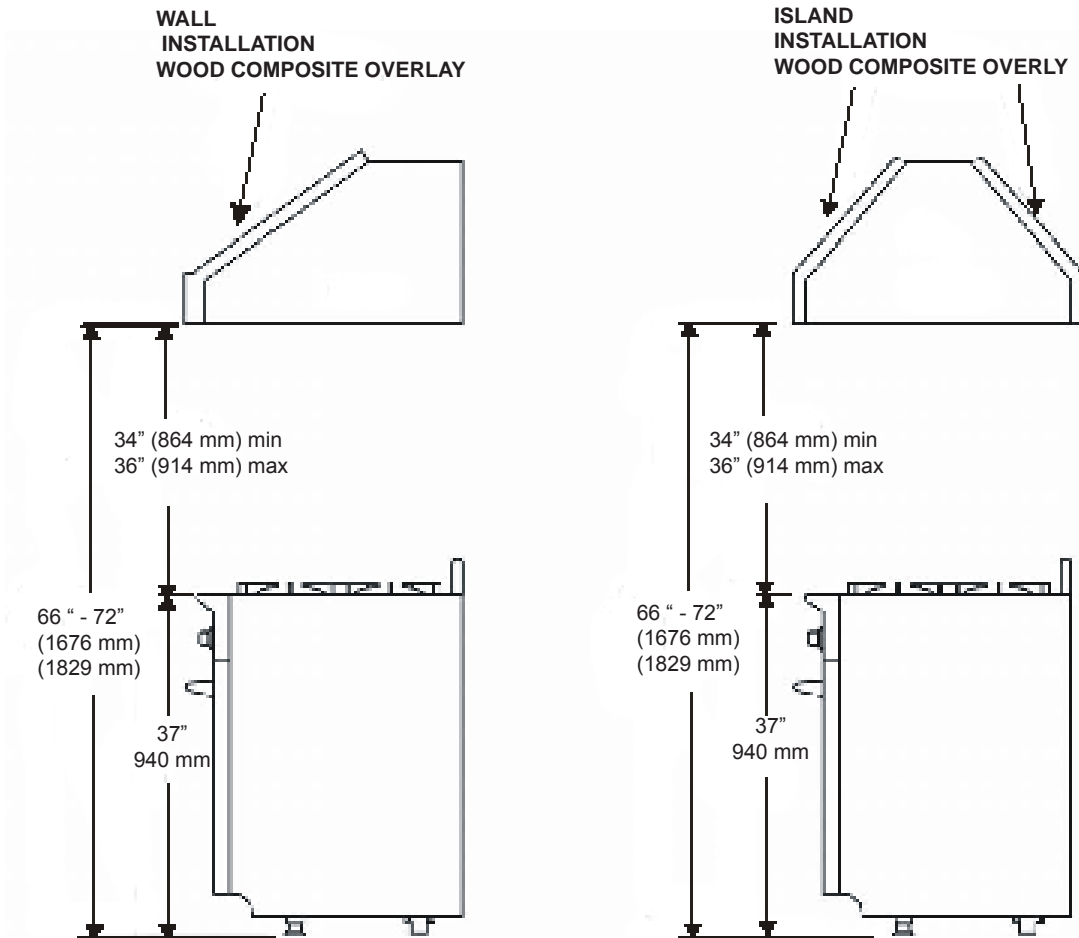

The bottom of an overhead hood should be 30" minimum to 36" above the countertop. This would typically result in the bottom of the hood being 66" to 72" above the floor. These dimensions provide safe an efficient operation of the hood.

INSTALLING THE ANTI-TIP BRACKET

Installation steps:

1. Position the range into the cabinet and mark the range's side edge line. (See Figures 1 and 2.)

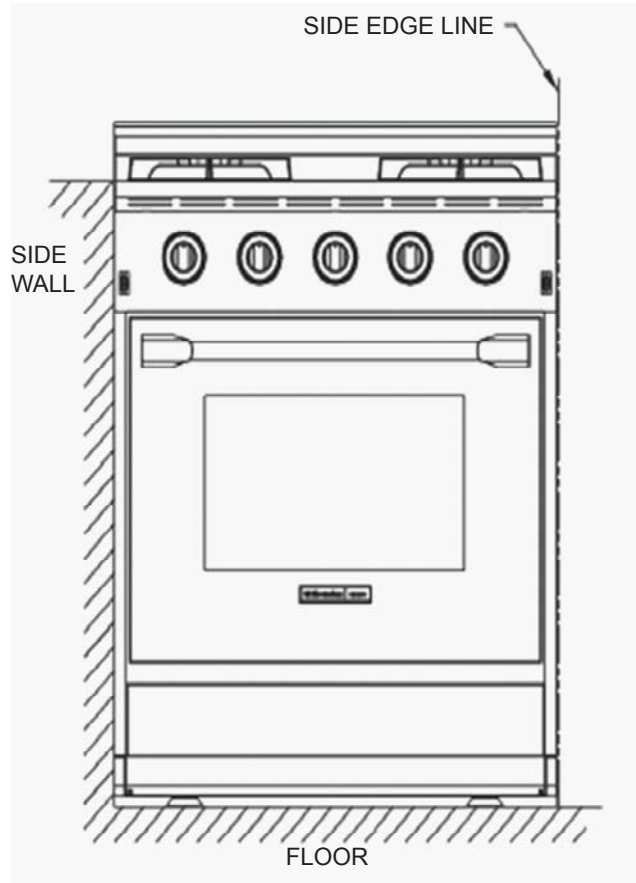

Figure 1

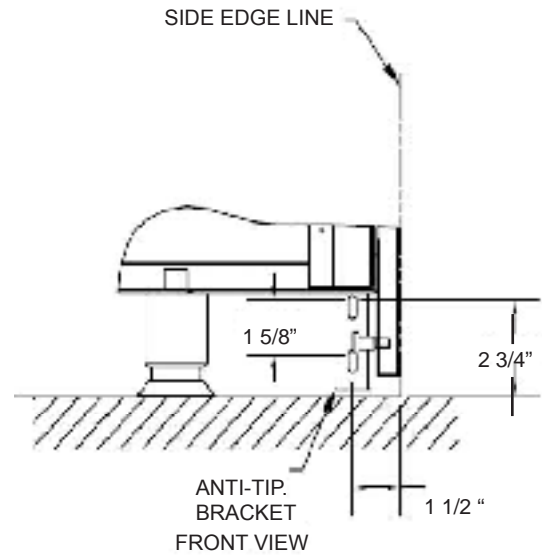

FIGURE 2

2. Mark the anti-tip wall mount bracket, as shown on figure 2:
 ** 2 1/4 inches above the floor and 1/2" from the side edge line.
 3. Use the self Screws supplied in the kit. For soft or concrete walls drill pilot holes and applies sleaze according to figure 3.
- ** Note: Increase or decrease as necessary for the range top to be flush with countertop.

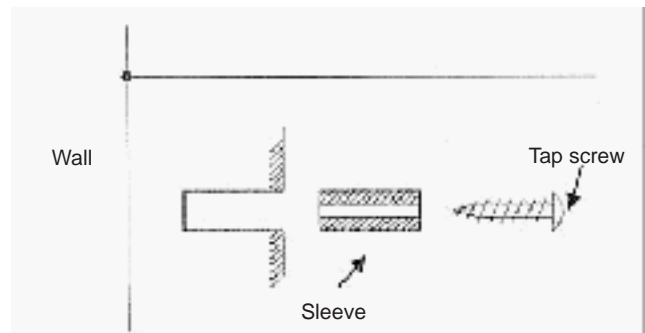

Figure 3

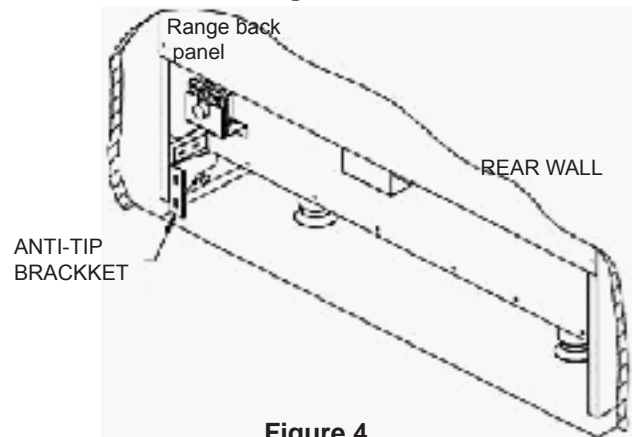
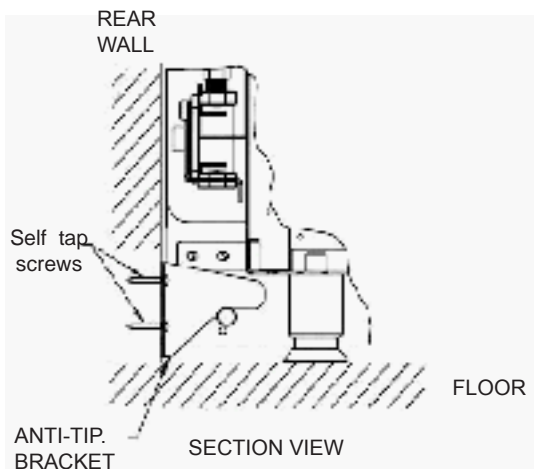

Figure 4

INSTALLING THE 36" RANGE OPTIONAL BACKGUARD

Your Electrolux IconMR range was shipped with a backguard in place. These instructions cover the installation of one of the optional backguards.

Installing the Range Optional Backguard:

WARNING

Be sure the range is not connected to gas or power before proceeding.

1. Remove existing backguard by removing 4 screws on rear of backguard (2 screws per side).
2. Remove the backguard from its box.
3. To avoid scratches, place small scraps of thin card board on the rear of the side panels where the backguard will make contact. With the assistance of at least one other person, carefully lift the backguard and place down on to the range top. Special attention should be given to the lower flange in front of the backguard, which must be fit between the stainless steel side panels.
4. Fasten the screws through the rear flange in the same location in which they were removed from factory supplied backguard.

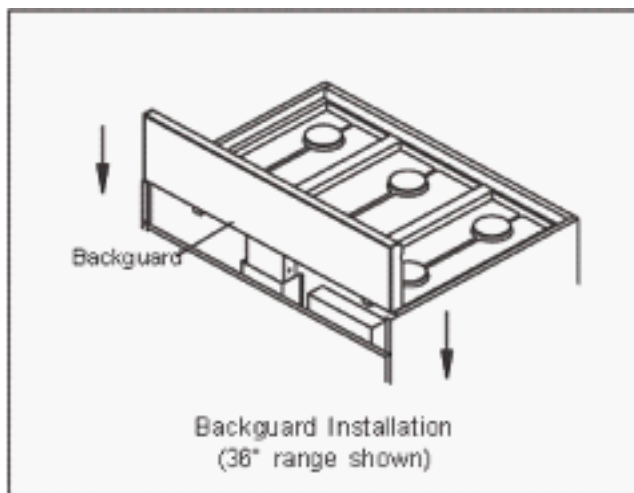

5. Connect the gas line to the regulator. Reposition and attach the access panel or the back cover if the entire back cover was removed.
6. You are now ready to continue with the range installation.

REMOVING THE OVEN DOOR

WARNING

Do not attempt to disengage the hinge catches with the door removed from the oven. The hinge springs could release causing personal injury. Do not lift or carry the oven door by the handle door.

Open the door to its fully opened position. Rotate the catch over the retaining arm on each hinge. Lift the oven door to about a 30 degree angle from the horizontal position. Pull the door away from the oven while continuing to lift.

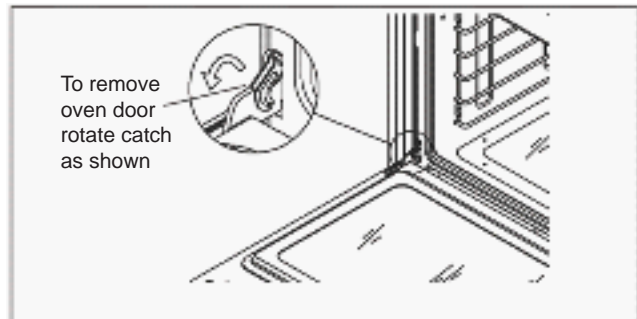

Figure 13

RE-INSTALLING THE OVEN DOOR

Grasp the oven door on opposite sides and lift it until the door hinges are aligned with the openings in the oven frame. Holding the door at about a 30 degree angle from the horizontal, slide the hinges into the openings until the bottom hinge arms drop fully into the two hinge receptacles. Lower the door to the fully opened position, and then rotate the two hinge catches toward the oven.

Open and close the door completely to ensure that it is properly installed.

Peel off the protective layer of plastic that covers the door panel.

GROUNDING

- 1 The range is equipped with a three-prong power cord (grounding plug which mates with a standard three-prong grounding wall receptacle to minimize the possibility of electrical shock hazard from the range).
- 2 Where a standard two-prong wall receptacle is encountered, it is the responsibility and obligation of the customer to have it replaced with a properly grounded three-prong wall receptacle. Do not cut or remove the grounding prong from the power cord.

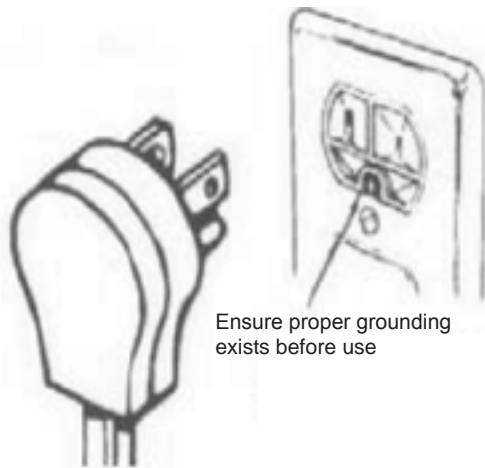

CONNECT RANGE TO GAS SUPPLY

- 1 Turn off gas.
- 2 Install a male 1/2" flare union adapter to 1/2" NPT internal thread of regulator inlet.
- 3 Connect flexible gas line connector to end union and regulator inlet.
- 4 Install the male flare union adapter on the manual shut-off valve, taking care to support the shut-off valve. Do not allow the valve to move or turn.
- 5 Position the range into the cabinet to allow connection of flexible connector at the shut-off valve.
- 6 When all connections have been made, make sure all range controls are in the "OFF" position and turn on main gas supply valve.
- 7 Use a leak detector at all joints and connections to check for leaks in the system. Do not use a flame to check for gas leaks.

The appliance must be isolated from the building's gas supply piping system by closing its individual manual shut-off valve during any pressure testing of the gas supply piping system at test pressures equal to or less than 1/2 psig (3.5kPa).

CONNECT RANGE TO GAS SUPPLY

WARNING

- Do not apply excessive pressure when tightening gas connections and fittings.
- Do not use teflon tape or plumber's putty on gas flex line connections.
- Turn all control valves to the "OFF" position. Turn on gas supply and check all lines and connections with leak detector, such as soap and water solution. Do not use flame to check for leaks. After verifying that there are no gas leaks, turn off the gas supply to the range by turning the gas shut-off valve to the "OFF" position.
- For LP installations, the LP gas tank must have its own high pressure regulator. This is in addition to the pressure regulator provided with the range.
- The maximum gas supply pressure to the regulator must never exceed 1/2 pound per square inch.

INSTALLING THE RANGE

Measure from the floor to the countertop and adjust the leveling legs as required to position the top frame at the desired height, based on the cabinet and countertop installation. Carefully slide the range into position in the cutout.

Make sure the anti-tip bracket is installed as directed

1. Slide range forward.
2. Make sure the anti-tip bracket is securely attached to the wall behind the range.
3. Safely slide the range slightly and move back against wall, making sure the pin slides under bracket.

Installing the burner components

Remove the burner bases, burner heads, burner caps,

and porcelain grates from their shipping packages. Place each burner onto its corresponding burner base, being certain that the burners align with the ignitor correctly. Set each burner cap on top of its corresponding burner ring. Place each grate onto the top frame.



WARNING

Never attempt to operate the cooktop section of the range with any of the burner rings, burner caps or grates removed.

Operation

VERIFYING THE OPERATION

Before beginning the test procedure, ensure that all cooktop control valves are in the “OFF” position, and all burner rings, burner caps, and grates are properly positioned on the top frame. Turn on the gas supply at the shut-off valve. Turn on the power supply to the range. Select a temperature of 350°F by rotating the oven selector knob to “350”. Rotate knob to the “Off” position to stop the heating process.

Test each top burner separately by pressing and turning one control knob at a time counterclockwise to the “HIGH” position. All ignitors will spark continuously, but only the burner with gas flowing to it will ignite. (It will take approximately 4 seconds for ignition to occur, at which time the ignitors will stop sparking. If ignition does not occur within 4 seconds, turn off the knob, wait for at least 2 minutes to allow any gas to dissipate, then repeat this ignition test.) The control knob can then be rotated counterclockwise from “HIGH” to “LOW” to adjust the flame height progressively.

Repeat the ignition test for all burners. When installed properly, the flame will be steady and quiet. It will also have a sharp, blue inner cone that will vary in length proportional to the burner size.



WARNING

- **The range and shut-off valve must be disconnected from the gas supply piping during any pressure testing exceeding 1/2 psi (3.5kPa).**
- **The range must be isolated from the gas supply piping by closing the shut-off valve during any pressure testing at or below 1/2 psi (3.5kPa).**

NOTES

If either the oven or cooktop does not operate properly follow these troubleshooting steps:

- Verify the power and the gas are supplied to the range.
- Check the electrical connections and gas supply to ensure the installation has been completed correctly.
- If the appliance still does not work, contact an authorized service company. Do not attempt to repair the appliance yourself. Electrolux is not responsible for service required to correct faulty installation.

TO ENSURE PROPER AND SAFE OPERATION

NOTE

REFER TO THE USE AND CARE MANUAL FOR DETAILED INSTRUCTIONS.

- Read all instructions before using this appliance. Install or locate the appliance only in accordance with the provided Installation Instructions.
- Do not attempt to adjust, repair, service, or replace any part of your appliance unless it is specifically recommended in this guide.
- Do not use the range for warming or heating the room.
- Do not leave children alone or unattended in the area where the range is in use. Never allow children to sit or stand on any part of the oven. Do not let children play with the range.
- All other servicing should be referred to a qualified service agency.
- Have the technician show you the location of the gas shut off valve and how to shut it off in an emergency situation.
- Always disconnect power to appliance before any type of servicing.
- Do not use abrasive or caustic cleaners or detergents on this appliance. They may cause permanent damage to the surface.

- When cooking, set the burner controls so that the flame heats only the bottom of the utensil and does not overlap at the sides of the utensil.
- Utensils (pots & pans) that conduct heat slowly, i.e. glass pots, should be used in conjunction with burner flames at a low or medium setting.
- Turn off all controls and wait for appliance parts to cool before touching or cleaning them.
- Do not touch the burner grates or surrounding areas until they are cool.
- Do not use water on grease fires.
- Clean appliance with caution.
- Always turn pot handles to the side or back of the range. Do not turn handles towards the area where they are easily burned. Handles should not extend over adjacent burners.
- Use range only for cooking tasks expected of a home appliance as outlined in this manual.
- When using the cooktop, do not touch the grates, burner caps, burner bases, or any other parts in proximity to the flame. These components may be hot enough to cause burns.
- Use dry potholders. Moist or damp potholders on hot surfaces may result in burns from steam. Do not let potholder touch hot surface areas. Do not use a towel or other bulky cloth.
- Do not heat unopened food containers. Build up of pressure may cause the container to explode and result in injury.
- During and after use, do not touch interior surfaces of the oven until cool.

NOTE

Prior to operating the cooktop or oven sections of the range, please read the accompanying Use and Care Manual carefully. Important safety, service and warranty information is contained within this manual.

SECTION C - THEORY OF OPERATION

Gas flow

The incoming gas flow is connected to a pressure regulator, which is mounted to the rear of the range.

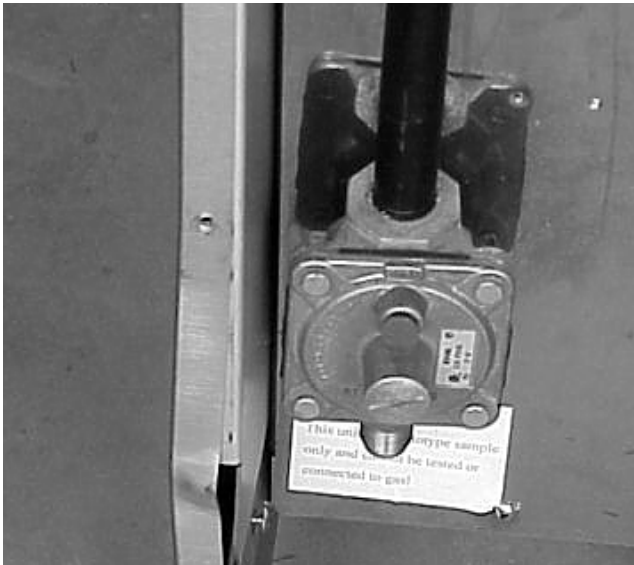

A pressure regulator is a device that maintains a constant fixed output pressure, by increasing or decreasing the gas flow in the range to match the output of the burners. The range is designed to operate on natural gas, only. The output of the regulator is set for 5 inches of water column pressure.

The pressure regulator is connected to a 1/2" pipe, which in turn is connected to the manifold pipe.

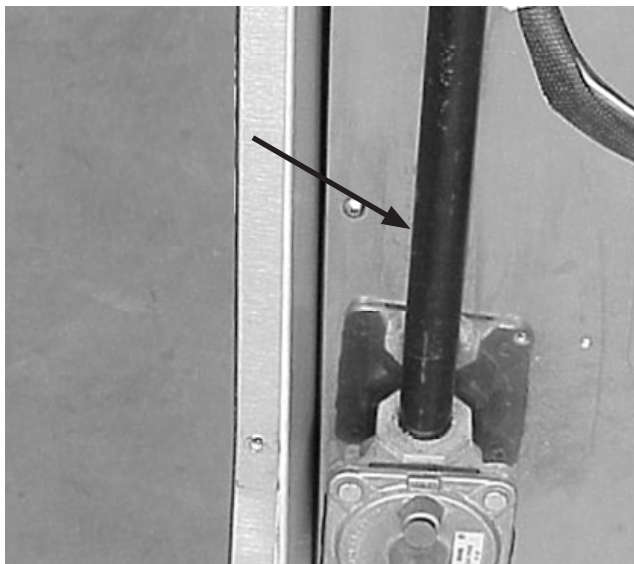

The manifold pipe is used to distribute gas to the top burner valves, oven and broil burners and the griddle.

The top burner valves are clamped to the manifold pipe and control gas flow to the main burner head orifice and the gas to the simmer burner.

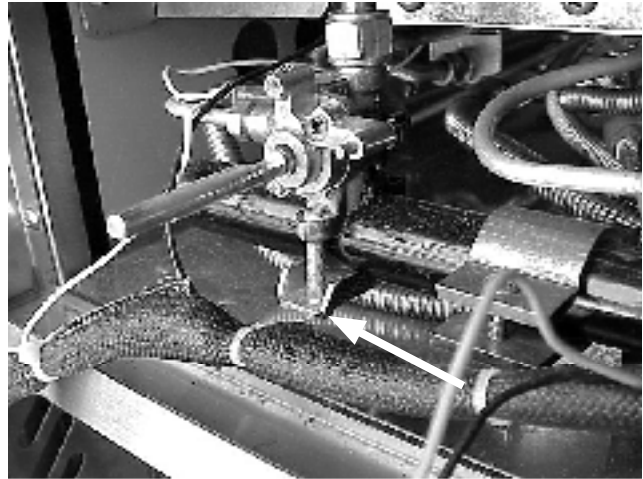

The valve is mounted to the manifold pipe so that the hole in the bottom of the valve is aligned with the hole of the manifold. This allows gas to enter into the valve.

There are two holes in the valve case. One that leads to the hole in the valve core that supplies the main gas to the top burner and one that leads to the channel in the valve core that supplies gas to the simmer and the minimum flame orifices.

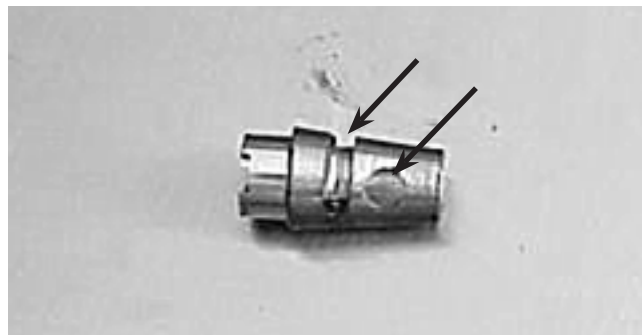

Note: The bypass and simmer burner orifices are fixed orifices, and not adjustable.

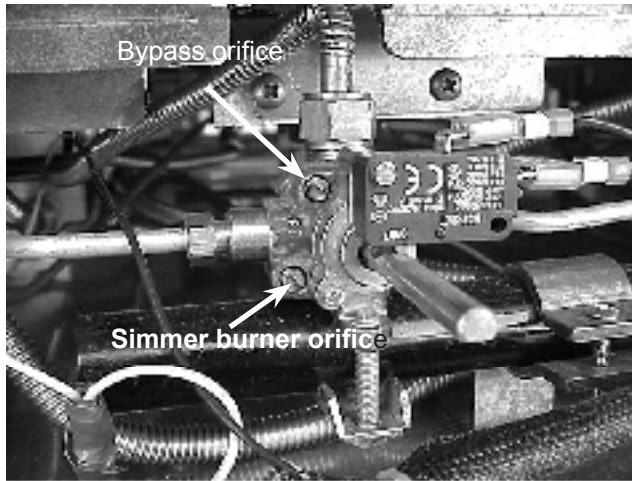

When the valve is in the off position the hollow core, in the center of the valve, prevents gas from flowing through either of the openings.

When the shaft of the valve is turned the hole and the channel in the core moves over the openings in the case of the valve. When the shaft is turned to the high position the hole and the channel in the core are completely aligned with the openings in the valve case and the maximum amount of gas is allowed to flow through the valve.

As the shaft is rotated off a high position the hole in the core is misaligned with a hole in the case and gas flow is reduced. When the valve is turned to the low position, the core seals off the hole in the case, removing the main gas supply from the burner. Gas is still allowed to flow through the channel in the core to the bypass and simmer orifices. This allows the simmer burner to operate, and the main burner to operate on minimum flame. When the valve is set to the simmer position, the core seals off the opening to the bypass orifice and the only gas that is allowed to flow is to the simmer burner.

The main gas from the valve is connected by flexible tubing to the burner orifice, mounted to a bracket underneath the drip pan. The simmer burner gas from the valve is connected by an aluminum tube to the simmer burner orifice mounted to the same bracket underneath the drip pan.

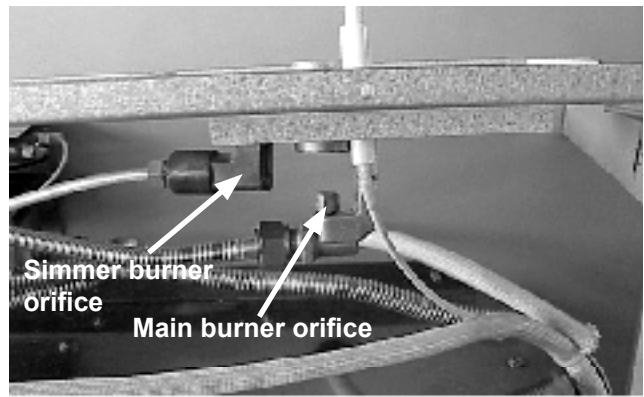

The orifice, or hole in the spud, serves two purposes; first it controls the maximum amount of gas to the burner and second it speeds up the gas flow as it enters the burner venturi.

When the main burner gas leaves the orifice it passes through the air gap between the orifice and the venturi tube. The movement of the gas through the air gap creates a vacuum, which draws air into the burner venturi, where the air and gas are mixed. For proper combustion the ratio of this mixture should be ten parts of air to one part of gas.

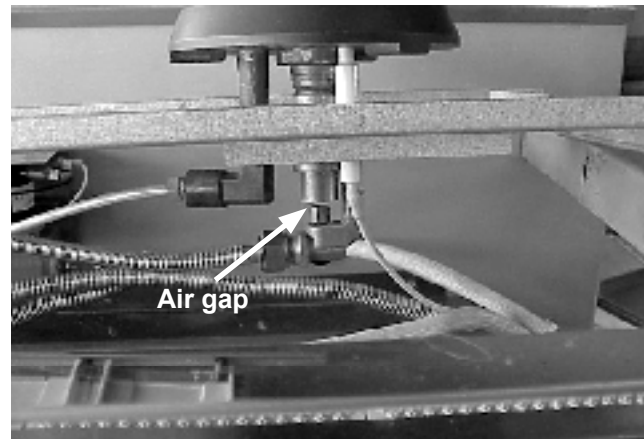

The venturi tube is screwed into the bottom of the burner base. The gas and air mixture is forced up the venturi tube into the burner head.

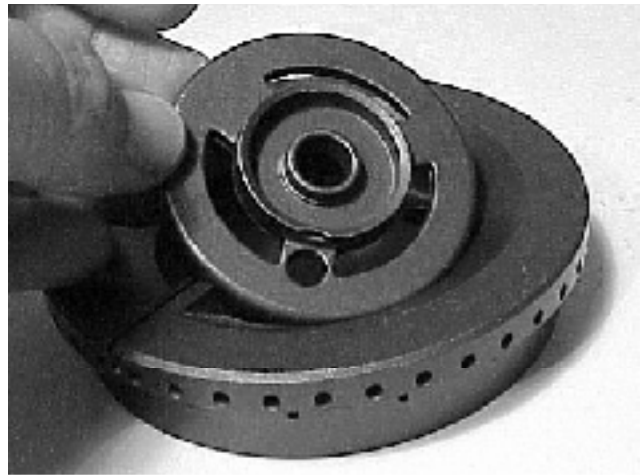

The simmer burner base has a channel that directs the gas to the hole in the center of the simmer burner base.

Inside the burner head the gas and air mixture is forced out of the burner ports to be ignited by the igniter.

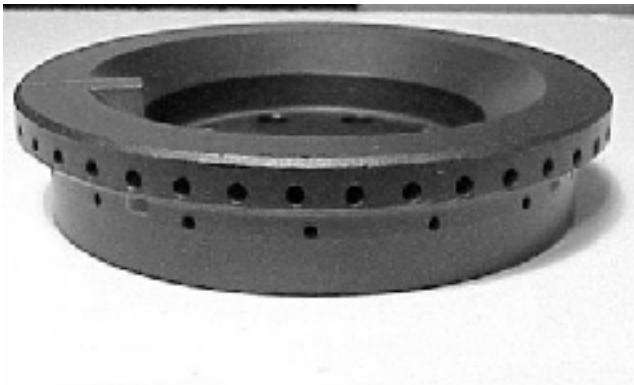

The gas for the simmer burner is injected into the tube that is formed in the bottom of the burner base. The tube directs the gas into the center of the burner head, which is covered by the simmer burner base.



The gas passes through the center hole into the simmer burner head. The gas exits the simmer burner head through the simmer burner ports.

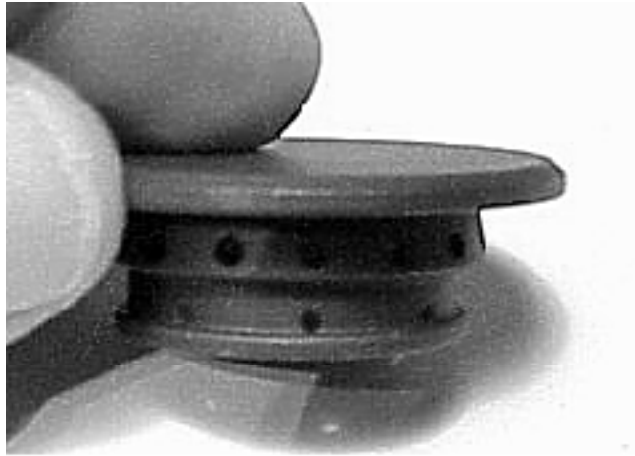

As a gas exits the simmer burner ports, it mixes with secondary air that is provided by the holes in the burner base, through the holes in the burner head and slots in the simmer burner base and forms a combustible mixture. The combustible mixture is then ignited by the igniter.

Top burner ignition and reignition system

The burner ignition and reignition system is made up of the ignition switches, that are mounted to the top burner valves,

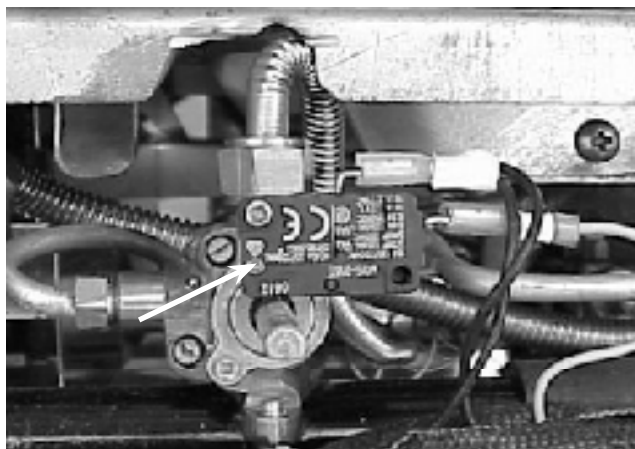

gas igniter/re-igniter module



and an igniter in each burner.

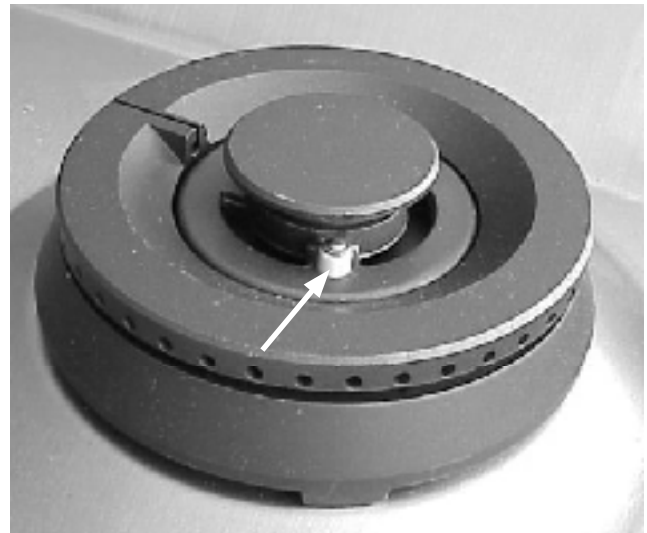

When the shaft of the valve is rotated from the off position the contacts of the igniter switch close and remain closed as long as the burner is on. This connects L1 to the module terminal for that burner. The module has two jobs; first to ignite the burner and once the burner has been ignited, to monitor the flame. When power is applied to the module, inside the module two things happened. First power is supplied to the step-up transformer, which in turn supplies power to the charging circuit and second an electrical signal is generated and applied to the igniter of the burner that is being ignited.

The output of the charging circuit is applied to all the igniters. The following explanation is how a simple ignition system works. When L1 is applied to the primary of the step-up transformer T1, the output voltage on the secondary side of transformer is increased. Since AC voltage is being applied to the transformer the ends of the transformer will change polarity every half cycle. In the drawing below, when the polarity of the transformer secondary winding is negative at the top and positive at the bottom, current flows in the circuit formed by the transformer secondary, diode D1, capacitor C1 and resistor R1. This charges C1 negative on the top and positive on the bottom. On the next half cycle, when the top of the transformer secondary winding is positive and the bottom is negative, the diode prevents current flow in the circuit and prevents the capacitor from discharging. At this point the capacitor also is prevented from discharging through the circuit formed by the capacitor, Ib1 (igniter bank one), the range chassis, Ib2 (igniter bank 2) and R1 by the dielectric of the air between the igniters and the burner heads. In this drawing the burner heads are considered part of the range chassis. The capacitor continues to charge every half cycle until the charge on the capacitor is high enough to break down the resistance of the air dielectric between the igniter tips and burner heads. At that time an electric spark occurs between all of the igniter tips and the burner heads. This allows current flow from the top of the capacitor to the Ib1, across the electrical arc into the range chassis and from the range chassis across the electrical arc into Ib2, through the resistor to the other side of the capacitor discharging the capacitor.

an electrical current. The electrical signal, sent by the module to the igniter, passes through the gas flame to the burner head. From the burner head the signal passes into the range chassis and returns to the module through the ground terminal on the module. This tells the module that flame is present on the burner. If for any reason the flame goes out, the circuit is interrupted. This tells the module to power the charging circuit and reignite the burner.

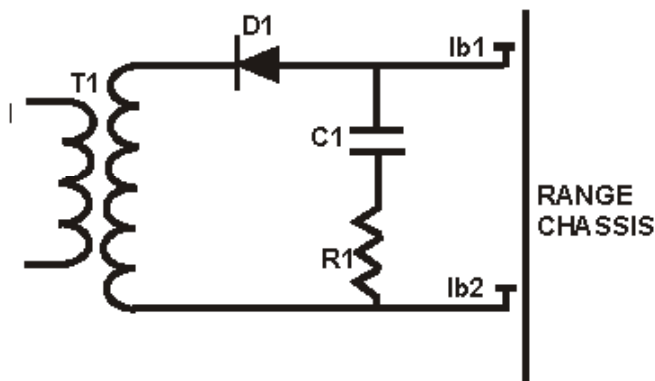

This cycle continues until the burner is ignited. The symbols Ib1 and Ib2 represents one half of the total top burner igniters each. If the range has four top burners Ib1 would represent two igniters and Ib2 would represent two igniters. The resistor R1 is placed in the circuit to slow down the charging time and control the number of sparks per second.

Once the burner has been ignited the module monitors the flames present by sending a small electrical signal to the igniter for that burner. A gas flame will conduct

Gas flow to the oven and broil burners

The gas to the oven and broil burner valves is supplied by the manifold pipe.

When gas is connected to the range gas, flows from the manifold pipe to both the oven and broiler safety valves.

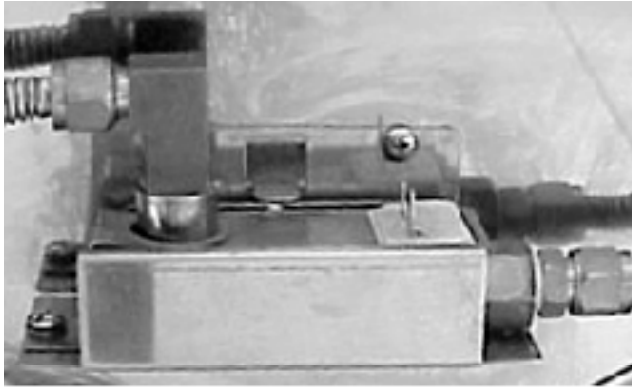

These valves are electrically operated and controlled by the oven thermostat. When a temperature is set on the thermostat the valve opens and allows gas to flow through either the oven orifice of the broiler orifice depending on which has been selected into the burner.

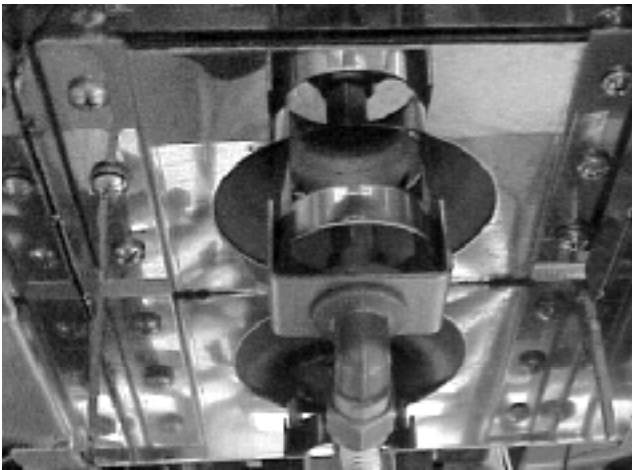

Gas flow 36" models with build-in griddle

The gas to the griddle burner valve is supplied by the manifold pipe.

When gas is connected to the range gas, flows from the manifold pipe to griddle safety valve.

The valve is electrically operated and controlled by the griddle thermostat. When a temperature is set on the thermostat the valve opens and allows gas to flow through griddle burner orifice into the burner.



Electrical operation of the oven and griddle burner

The electrical operation of the oven and griddle is made up of a thermostat,

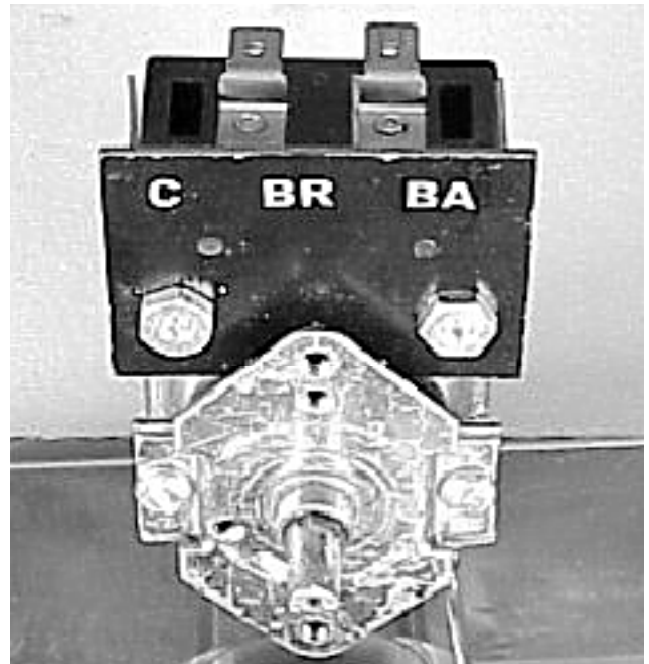

Note: Oven thermostat shown here

the silicon carbide igniter



Oven and broiler

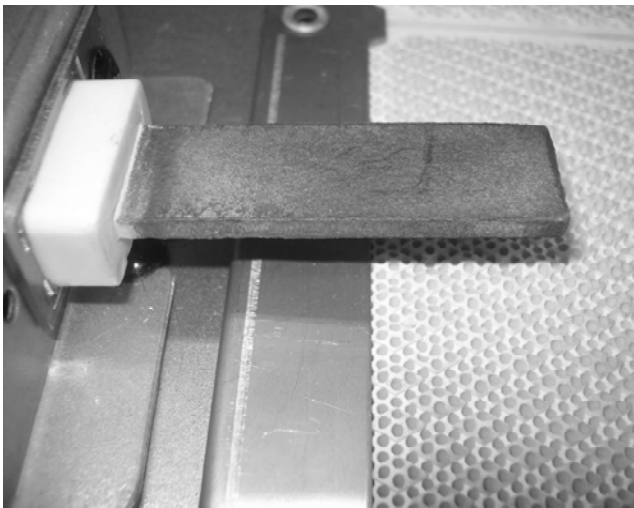

Griddle

and a current sensitive safety valve.

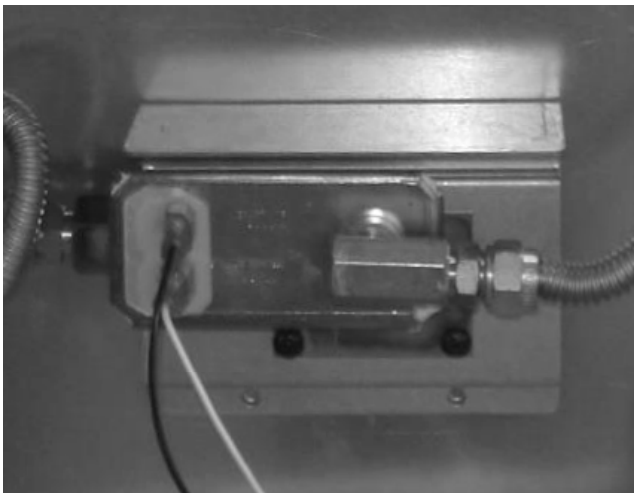

Oven circuit

When electrical power is applied to the range, power is applied to one side of the cycling contacts of the thermostat. When the thermostat dial is set to a temperature, the cycling contacts of the thermostat close and connect power to terminal C of the selector switch portion of the thermostat. With the thermostat dial set to a temperature that contacts between terminal C and terminal BA close applying power to one side of the oven burner igniter. The other side of the igniter is connected to one of the terminals of the oven safety valve. The other side of the oven safety valve is connected to neutral completing the circuit. The thermostat, igniter and oven safety valve form a series circuit. The oven igniter is a silicon carbide igniter that decreases in resistance as it heats up. The oven safety valve is a current sense of the valve that will open when the current flow in the circuit reaches 3.2 amps. At room temperature, the resistance of the oven igniter is above 50 ohms. When power is applied to the series circuit form by the thermostat, igniter and oven safety valve, the current flow in the circuit closes the igniter to heat. As the temperature of the igniter increases the resistance of the igniter decreases in the current flow in the circuit increases. When the temperature of the igniter reaches about 1800°F the current flow in the circuit increases to above 3.2 amps, which opens a safety valve allowing gas to flow into the oven burner. A combustible mixture of gas and air will ignite at 1100°F., therefore when the oven safety valve opens the gas and air mixture is ignited by the 1800° igniter.

When a thermostat dial is turned to broil the contacts between terminal C. and terminal BR. closed providing power to the broil igniter and the broil burner safety valve. The operation of the broil circuit is identical to the oven burner circuit.

Note: Terminal BR is also connected to the convection fan relay coil. When power is applied to BR. The convection fan relay activates opening the contacts that provide power to the convection fan motor. This prevents the convection fan from operating. When the broiler is being used.

Oven and broiler circuit

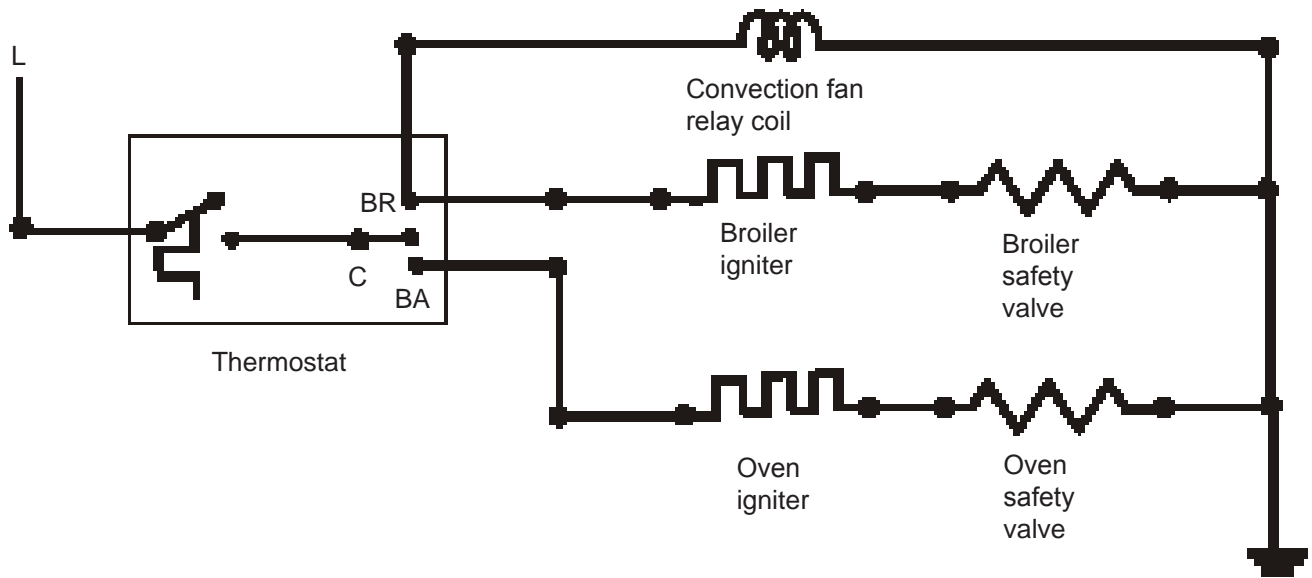

Griddle circuit

The electrical operation of the griddle circuit is the same as the oven circuit, except the thermostat does not have a selector section.

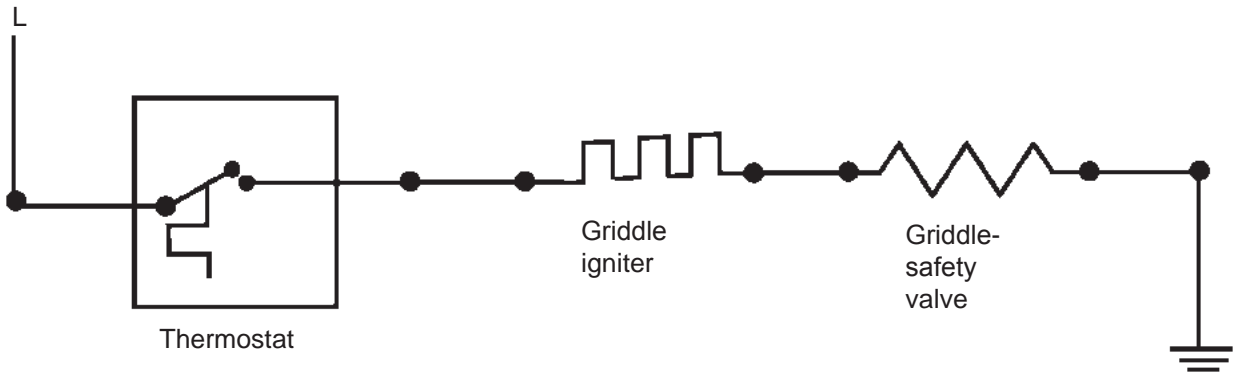

Electrical operation of the convection fan motor

and the convection fan motor.

The convection fan motor circuit is made up of the convection fan switch,

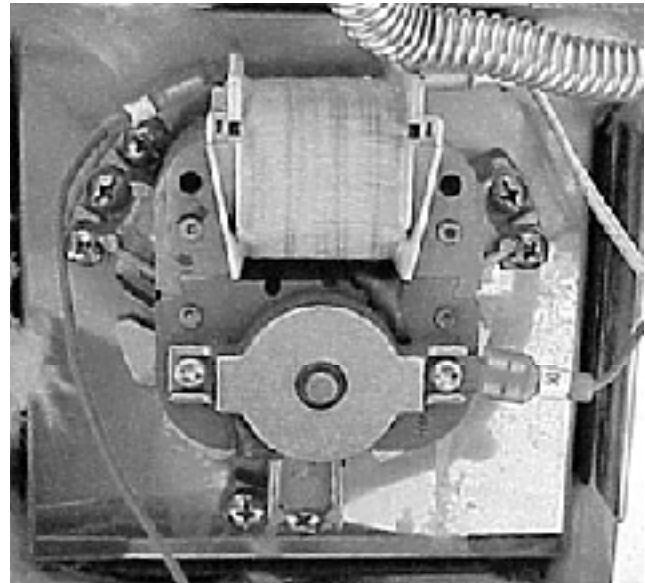

the convection fan relay

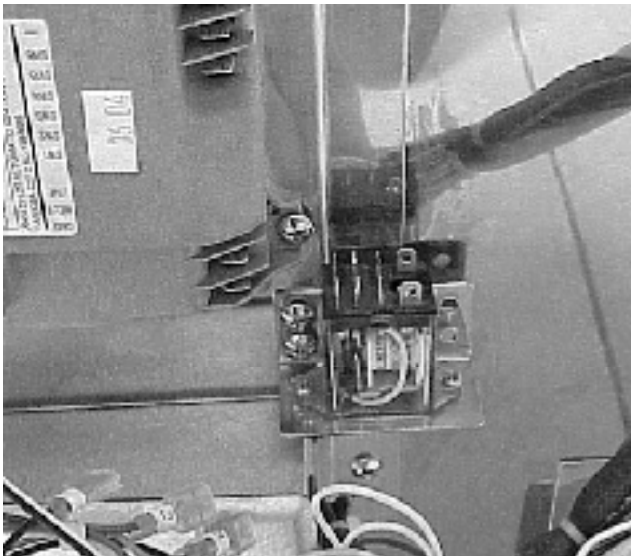

When electrical power is applied to the range, power is applied to one side of the convection fan switch. When the convection fan switch is pushed, closing the contacts of the switch, power is applied to the contacts of the convection fan motor relay. The contacts of the convection fan relay are normally closed when the relay is de-energized. From the contacts of the relay power is applied to the convection fan motor causing the fan motor to run. The convection fan relay is placed in the circuit to prevent the convection fan from operating when the broiler burner is operating.

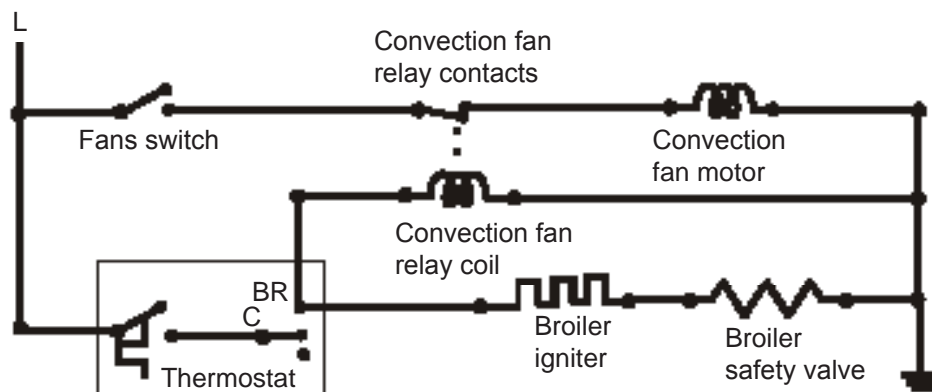

SECTION D -TROUBLESHOOTING

NOTE: Always check the wiring and pin/plug connectors before replacing any component.

Index

Electrical components will not operate. _____	60
Burner flame too large and yellow. _____	60
Burner flame too small. _____	60
Flame goes out when the valve is turned to the simmer position. _____	60
Top burners, not burning properly. _____	60
One top burner, not burning properly. _____	61
Top burner valve difficult to turn. _____	61
Igniters do not spark when the burner knob is turned to the lite position. _____	61
Igniters spark but burner does not ignite. _____	61
Igniters continue to spark after burner is ignited. _____	61
Oven does not operate in either bake or broil. _____	62
The oven operates in broil, but not in bake. _____	63
The oven operates in bake, but not in broil. _____	63
Ovan calibration more than 20° off. _____	63
One oven light does not work. _____	63
Griddle is not operate. (36 “model ranges) _____	64
Convection fan motor does not run when the switch is turned on. _____	64
Ovan lights does not operate. _____	64

FAILURE	CHECK	CORRECTION
Electrical components will not operate.	<ol style="list-style-type: none"> 1. Check fuse or circuit breaker. 2. Check for line to neutral voltage, at the range terminal block. 	<p>If defective replace the fuse or reset the circuit breaker. If good go to step (2)</p> <p>If the voltage reading is correct, there's a wiring problem in the range, check the range wiring.</p> <p>If the voltage readings are incorrect, defective house wiring or defective range power cord.</p>
Burner flames too large and yellow.	<ol style="list-style-type: none"> 1. Check gas pressure at the oven burner under flow. The pressure reading should 5 inches of water column pressure for natural. Is the pressure reading correct? 	<p>Yes, check for something blocking the air inlet to the burners.</p> <p>No, check gas supply pressure, the pressure regulator or for a restriction in the gas line.</p>
Burner flame too small.	<ol style="list-style-type: none"> 1. Check gas pressure at the oven burner under flow. The pressure reading should 5 inches of water column pressure for natural. Is the pressure correct? 	<p>Yes, restricted orifice.</p> <p>No, defective regulator or low incoming gas pressure.</p>
Flame goes out, when valve is turned to the simmer position.	<ol style="list-style-type: none"> 1. Has the simmer bypass jet been turned? 	<p>Yes, readjusts the simmer bypass jet.</p> <p>No, clean the bypass jet, and the simmer burner orifice.</p>
Top burners, not burning properly.	<ol style="list-style-type: none"> 1. Are the burner bases and heads installed correctly? 2. Check gas pressure at the oven burner under flow. The pressure reading should be 5 inches of water column pressure for natural. Is the pressure correct? 	<p>Yes, go to step (2).</p> <p>No, install burner bases in heads correctly.</p> <p>Yes, checked the burner orifices.</p> <p>No, checked gas supply pressure, the pressure regulator or for a restriction in the gas line.</p>

Note: Always check the wiring between the components

FAILURE	CHECK	CORRECTION
One top burner, not burning properly.	1. Is the burner base and head installed correctly?	Yes, go to step (2). No, install burner base and head correctly.
	2. Is the orifice, flexible tube or top burner valve restricted?	Yes, remove the restriction or replace the part.
		No, clean the burner ports
Top burner valve difficult to turn.	1. Can the valve stem be depressed far enough to unlock the valve.	Yes, replace the valve. No, check the distance between the console and the manifold pipe.
Igniters do not spark when the burner knob is turned to the lite position.	1. Does a snapping sound occur when the valve is turn to the lite position?	Yes, wires between module and igniters shorted the chassis. No, go to step (2).
	2. Measure the input voltage to one of the top burner switches. Is the reading line to neutral?	Yes, go to step (3). No, open wire between range terminal block, and switch.
	3. With the valve set to the lite position measure the output voltage of the valve switch. Is the reading line a neutral?	Yes, replace the spark module. No, replace the valve switch
Igniters spark but burner does not ignite.	1. Is the burner heads installed correctly?	Yes, go to step (2). No, install heads correctly.
	2. Lite the burner with a match. Is the flame adjusted properly?	Yes, remove and clean the heads. No, check for a restriction.
Igniters continue to spark after burner is ignited.	1. Is the flame adjusted properly?	Yes, remove and clean the heads. Check ground wire to module. Replace module. No, check for a restriction.

Note: Always check the wiring between the components

FAILURE	CHECK	CORRECTION
Oven does not operate in either bake or broil.	1. Turn the oven thermostat to a temperature. Does the oven indicator light low?	Yes, go to step (3). No, go to step (2).
	2. Measure the input voltage to the oven thermostat. Does the meter read line to neutral voltage?	Yes, go to step (3). No, open wire between range terminal block, and oven thermostat.
	3. Measure the voltage drop between terminal BA, and neutral. Does the meter read line to neutral voltage?	Yes, go to step (4). No, defective oven thermostat.
	4. Does the oven igniter glow?	Yes, go to step (6).
		No, go to step (5).
	5. Measure the voltage drop between the input terminal on the of the oven safety valve and neutral. Does the meter read line to neutral voltage, 2 to 4 VAC or zero?	Line to neutral, defective ovan safety valve.
		2 to 4 VAC, go to step (6).
		Zero, defective oven igniter.
	6. Check the oven manual shut off. Is the shut off turned on?	Yes, defective oven igniter, goto step (7).
No, turn manual shut off on.		
7. Measure the voltage drop between terminal BR, and neutral. Does the meter read line to neutral voltage?	Yes, go to step (8).	
	No, defective oven thermostat.	
8. Does the broiler igniter glow?	Yes, defective broiler igniter.	
	No, go to step (9).	
9. Measure the voltage drop between the input terminal on the of the broiler safety valve and neutral. Does the meter read line to neutral voltage?	Yes, defective broiler safety valve.	
	No, defective broiler igniter.	

Note: Always check the wiring between the components

FAILURE	CHECK	CORRECTION
The oven operates in broil, but not in bake.	1. Turn the oven thermostat dial to a temperature. Does the oven igniter glow?	Yes, defective igniter. No, go to (2).
	2. Measure the voltage drop between BA and neutral. Does the meter read line to neutral voltage.	Yes, go to (3). No, defective oven thermostat.
	3. Measure the voltage drop between the input terminal of the oven safety valve and neutral. Does the meter read line to neutral voltage.	Yes, defective bake safety valve. No, defective bake igniter.
The oven operates in bake, but not in broil.	1. Turn the oven thermostat dial to broil. Does the broil igniter glow?	Yes, defective broil igniter. No, go to step (2).
	2. Measure the voltage drop between BR and neutral. Does the meter read line to neutral voltage?	Yes, go to step (3). No, defective oven thermostat.
	3. Measure the voltage drop between the input terminal of the broil safety valve and neutral. Does the meter read line to neutral voltage?	Yes, defective broil safety valve. No, defective broil igniter.
Ovan calibration more than 20° off.	1. Is the correct knob on the oven thermostat?	Yes, replaced the thermostat. No, put the correct knob the thermostat.
	Note: On the 36 inch models. The thermostat knob and the griddle knob can be switched.	
One oven light does not work.	1. Defective light bulb or socket.	Replace a lightbulb if problem is not corrected replaces socket.

FAILURE	CHECK	CORRECTION
Griddle does not operate. (36 " model ranges)	1. Turn the griddle thermostat to a temperature. Does the griddle indicator light glow?	Yes, go to step (2). No, defective thermostat or open wire between griddle thermostat and range terminal block.
	2. Does a griddle igniter glow?	Yes, go to step (3). No, go to step (4).
	3. Is the griddle manual shut off turned on?	Yes, defective igniter. No, turn the manual shut off on.
	4. Measure the voltage drop between the input terminal of the griddle safety valve and neutral. Does the meter read line to neutral voltage.	Yes, defective griddle safety valve. No, defective griddle igniter.
Convection fan motor does not run when the switch is turned on. Note: The convection fan motor will not run if the oven thermostat is set to broil.	1. Measure the input voltage to the convection fan motor switch. Does the meter read line in neutral voltage?	Yes, go to step (2). No, open wire between convection switch and range terminal block.
	2. Turn the switch on and measure the voltage drop across the two terminals of switch. Does the meter read line a neutral voltage?	Yes, defective convection switch. No, go to step (3).
	3. Measure the voltage drop across the terminals of the convection fan motor. Does the meter read line a neutral voltage?	Yes, block fan blade or defective convection motor. No, defective convection fan relay.
Ovan lights does not operate.	1. Replace the lightbulbs. Did this correct the problem?	Yes, problem solved. No, go to step (2).
	2. Measure the voltage drop between the input terminal of the light switch and neutral. Does the meter read line to neutral voltage?	Yes, go to step (3). No, open wire between the lightswitch, and the range terminal block.
	3. Measure the voltage drop between the output terminal of the lightswitch and neutral. Does the meter read line to neutral voltage?	Yes, defective light sockets. No, defective light switch.

SECTION E - TEARDOWN

This section will describe how to remove components from the range. Unless stated, the procedure will be the same on all models. Unless stated, reverse the procedure to reinstall the component.

 **WARNING** Always remove electrical power from the range when working in an area where electrical power is present.

 **WARNING** Always turn the gas off to the range before opening any gas piping.

Note: Not all components are in all models.

Removing the top grates:

1. The top grates lift off.



Removing the simmer burner cap:

1. The simmer burner cap lift off.



Removing the simmer burner base:

1. The simmer burner base lift off.



Removing the main burner head:

1. Lift the main burner head up to clear the igniter and lift it off.



Removing the main burner base:

1. Lift the main based to clear the igniter and off.



Removing the griddle grease tray:

1. Raise the front of the griddle cover, pull the tray towards the front of the range and lift it out.



Removing the griddle cover: (36" models with built-in griddle)

1. Raise the front of the griddle cover, pull a cover forward and off.



Removing the backguard:

1. Obtain access to the rear of the range, remove the (4) screws, two at each end.

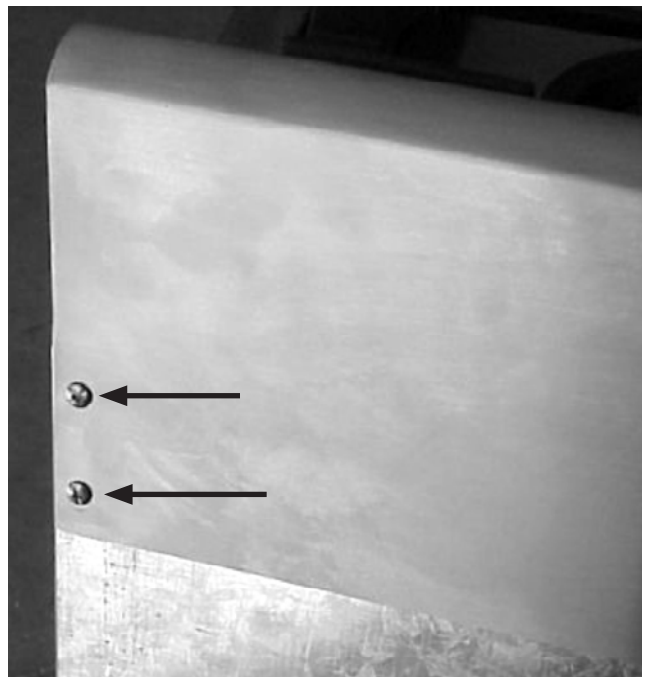

2. Pull the backguard to the rear to disengage the tabs and lift it off.



Removing the knob:

1. The shaft of the knobs are D-shaped and the knobs will pull straight off.



Removing the griddle: (36 inch models with built-in griddle)

1. Disconnect power from a range and remove the griddle cover, grease tray and the backguard.
2. Lift the front of the griddle and remove the griddle thermostat bulb from the channel in the bottom of the griddle.

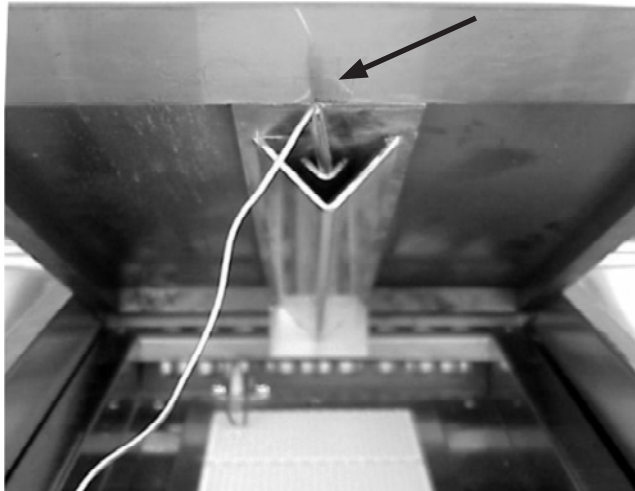

Removing the knobs bezel:

1. Remove the knob.
2. Remove the (2) screws holding the bezel to the control panel.



3. Lift the griddle off the range.

Note: The griddle is heavy.

Removing the top burner orifice:

1. Remove the burner head and base.
2. Using a 7 mm socket, turn the orifice counterclockwise and lift it out.

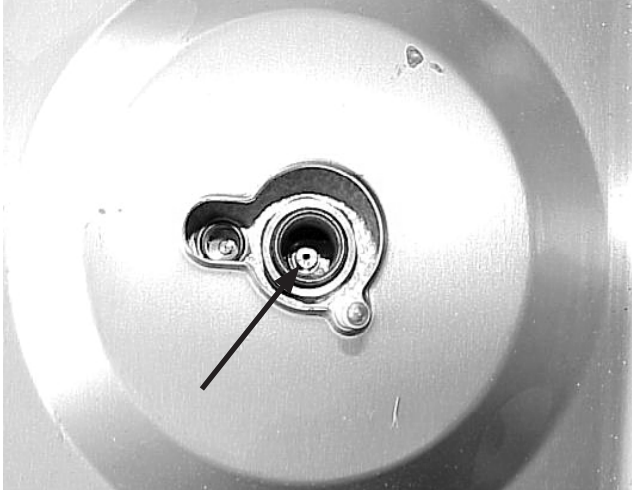

3. Remove the (3) screws holding the bottom of control panel to the front frame.

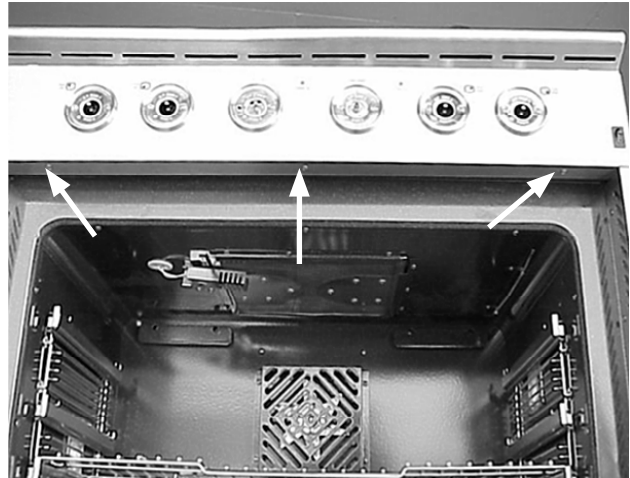

4. Allow the bottom of the control panel to swing out and drop the control panel down to release the (3) tabs at the top.

Removing the simmer burner orifice:

1. Remove the burner head and base.
2. Using a 5/32 socket, turn the orifice counterclockwise and lift it out.

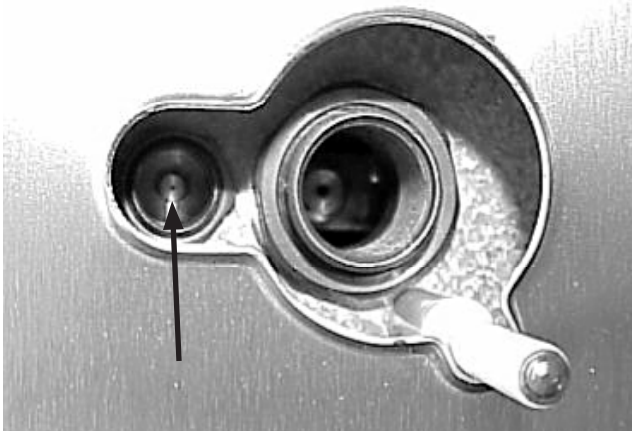

Removing the control panel:

1. Disconnect power from range and release control panel.

Releasing the control panel:

1. Disconnect power from the range and remove the knobs.
2. Open the oven door.

- Remove the (2) screws holding the oven thermostat and the (2) screws holding the griddle thermostat, if equipped, to the control panel.

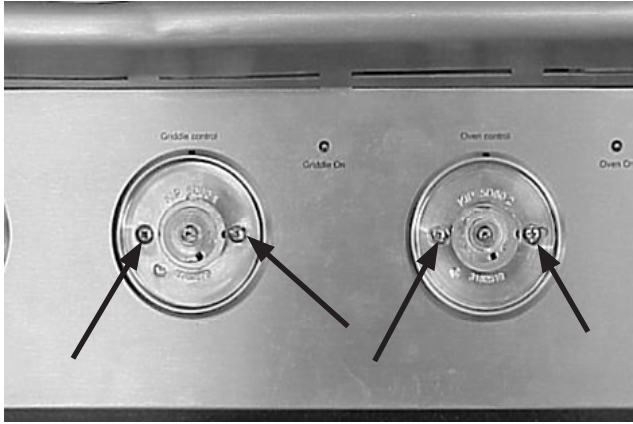

- Disconnect the indicator lights from their lenses and lift the panel off.

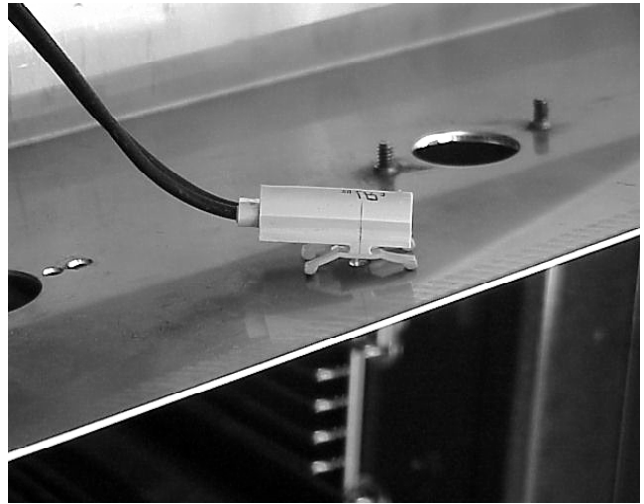

- Lift the control panel out and disconnect the wires from the convection fan switch and the oven light switch.

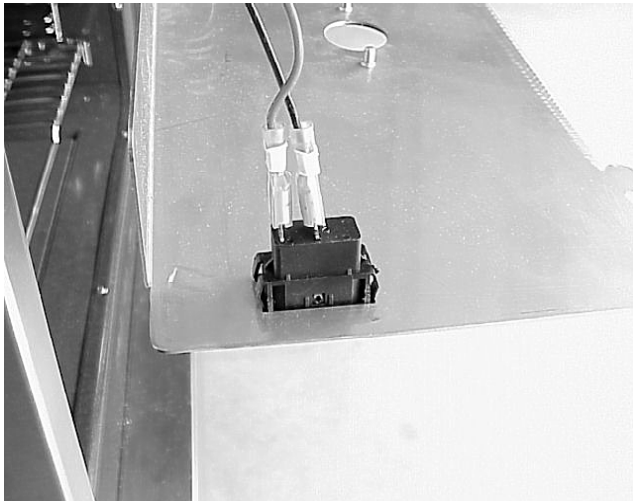

Removing the oven light switch:

- Disconnect power from range and release control panel.
- Disconnect the wires from the switch.
- Squeeze the spring-loaded tabs at the top and bottom of the switch and push the switch out of the control panel.

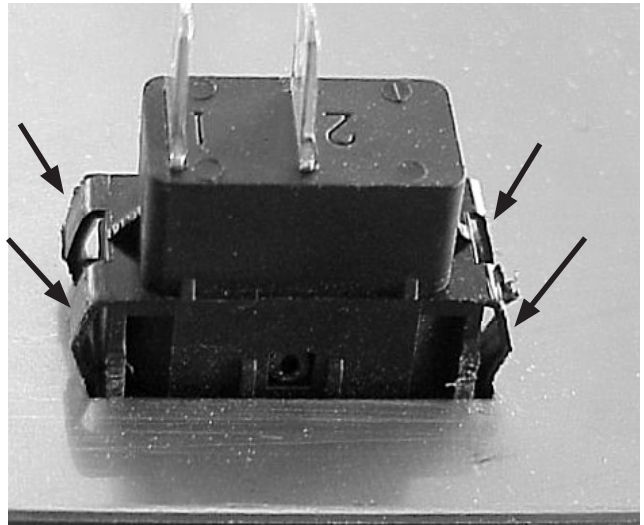

Removing the convection fan switch:

- Disconnect power from range and release control panel.
- Disconnect the wires from the switch.

3. Squeeze the spring-loaded tabs at the top and bottom of the switch and push the switch out of the control panel.

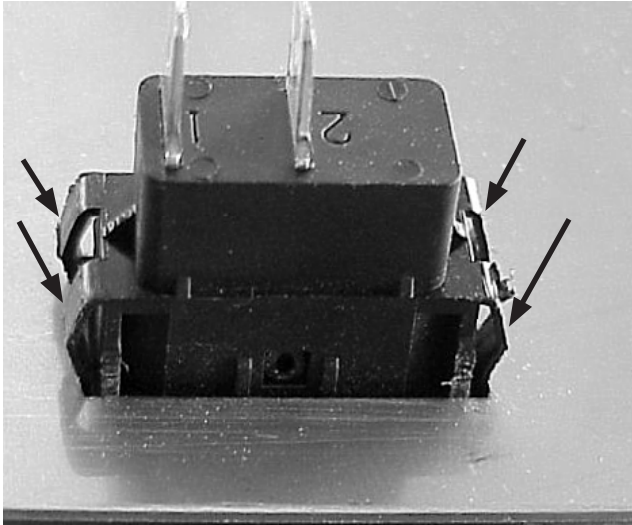

2. Disconnect the wires from the switch, remove the screw holding the wires to the valve and slide the switch forward off of the switch locating pin.

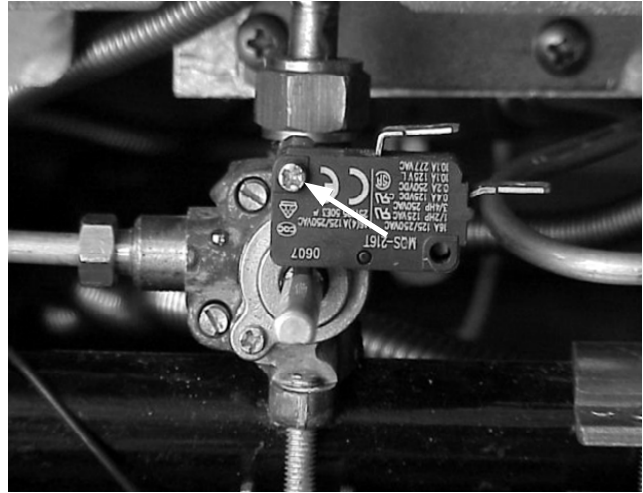

Removing the oven or griddle indicator lights:

1. Disconnect power from range and release control panel.
2. Disconnect the indicator light wires in the harness.
3. Press the light to the control panel and disengage the light from the lens.

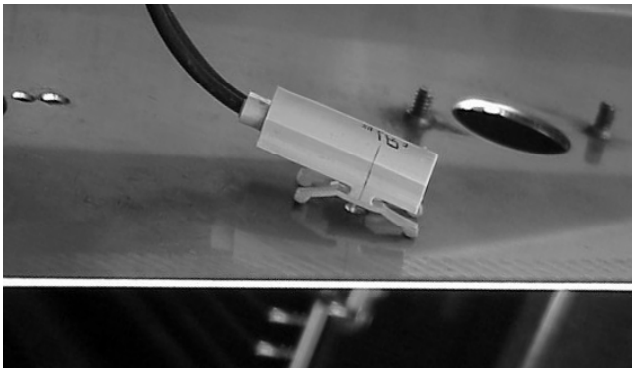

Removing the top burner valve switch:

1. Disconnect power from range and release the control panel.

Removing the top bypass orifice:

1. Disconnect power and be sure the gas valve is turned off.
2. Release the control panel.
3. Using a common screwdriver, turn the bypass orifice counterclockwise.

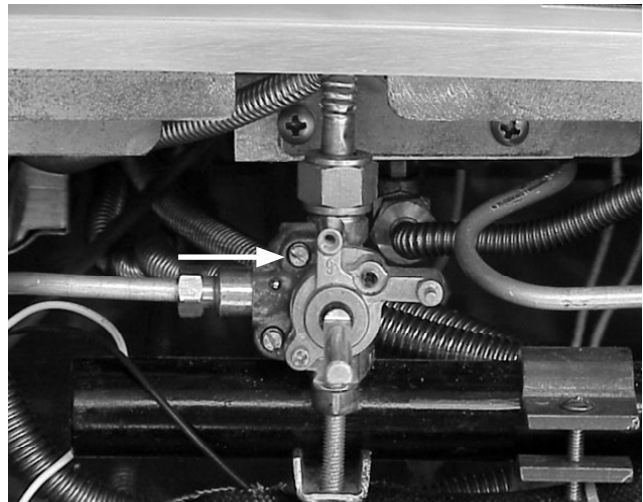

Removing the top simmer burner orifice:

1. Disconnect power and be sure the gas valve is turned off.
2. Release the control panel.

- Using a common screwdriver, turn the simmer burner orifice counterclockwise.

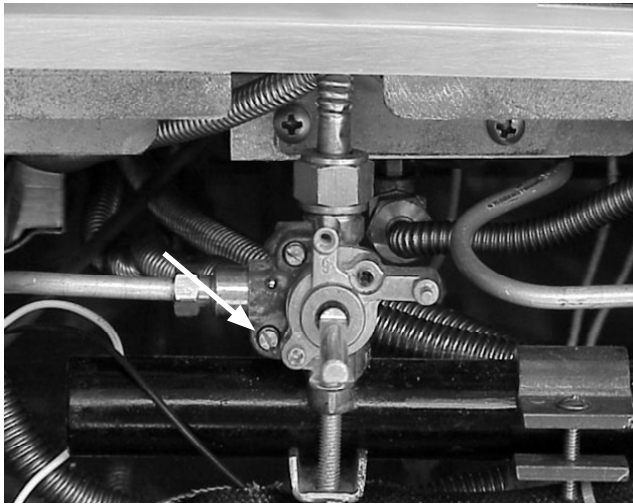

- Remove the control panel, control panel trim and the burner valve switch.

- Using a 5/8" wrench disconnect the main gas line to the burner.

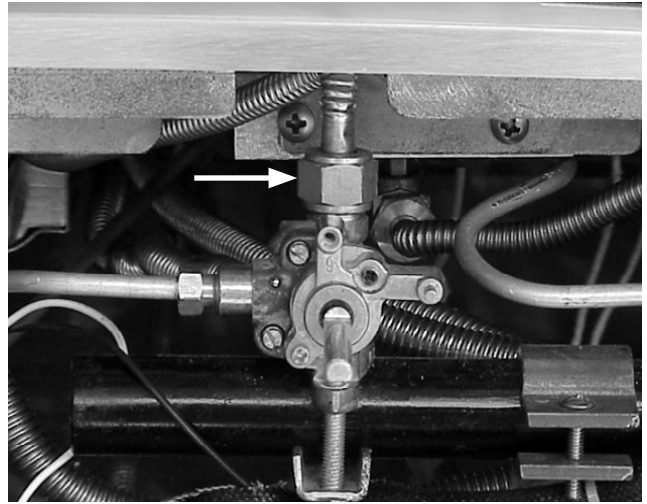

Removing the control panel trim:

- Disconnect power and remove the control panel.
- Remove the (4) screws, two on each end, and lift the trim off.



- Using a 10 mm wrench disconnect the simmer burner gas line from the valve

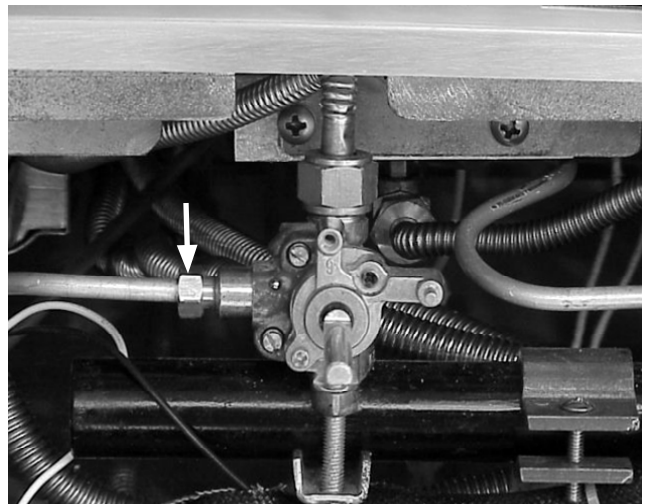

Removing the top burner valve:

- Disconnect power and turn the gas off to the range.

- Using a 5/16" wrench removes the (2) bolts clamping the valve to the manifold and lift the valve off of the manifold.

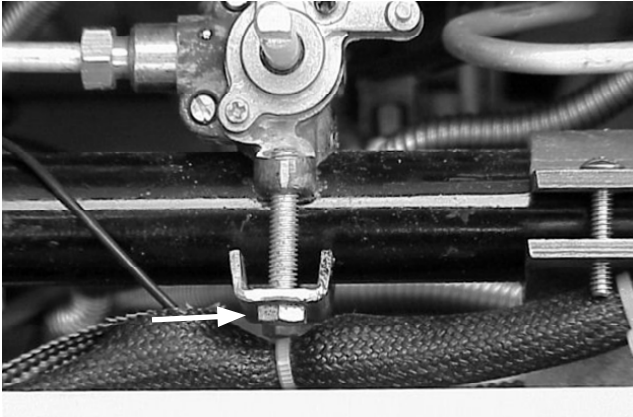

Note: Before reinstalling or replacing the valve make sure the rubber seal and locating cylinder are in place.

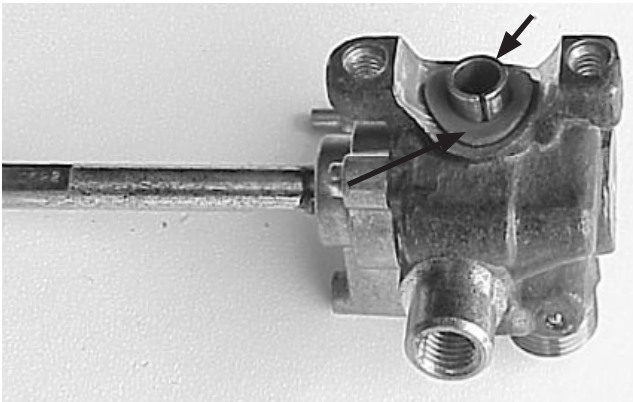

Note: When reinstalling the valve, connect the flexible tubing first, then set the valve on the manifold pipe and tighten down the clamp, then connect the simmer burner gas tube.

Removing the oven door:

- Rotate the hinge locks to the door so that when the doors is closed they will take the spring pressure off the hinges.



- Close the door until you feel, the hinges release from the guide pin and then lift out on the door.

Removing the oven door seal:

- Open the oven door.
- The oven door seal is held to the inner liner of the oven door by spring clips and can be pulled straight off.



Removing oven door handle:

1. Using a 3/32" Allen wrench remove the (4) set screws, two from the bottom of each end of the handle, and lift the handle off.

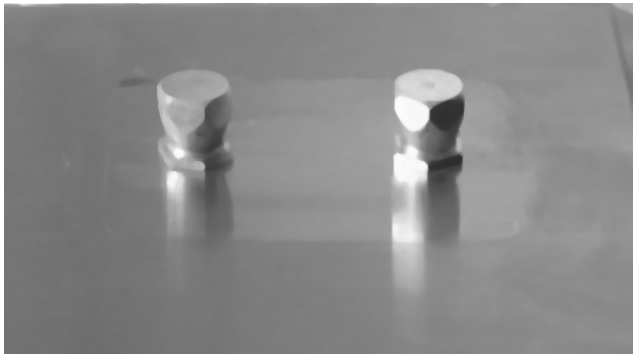
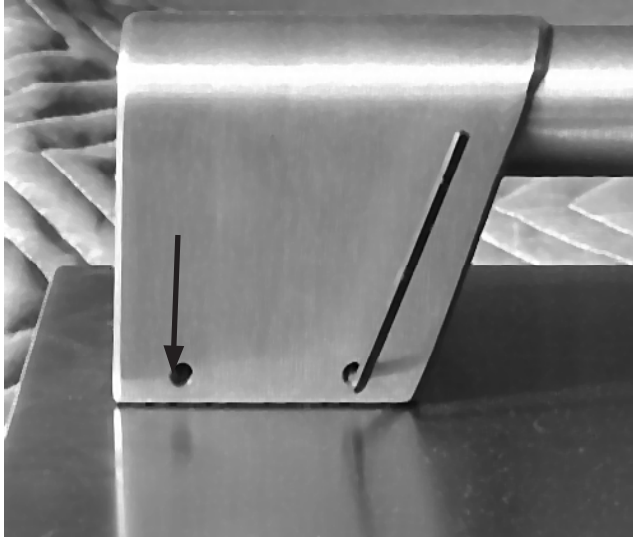

Removing outer door panel assembly:

Note: The outer door panel, outer glass and Electrolux logo are replaced as a package.

1. Remove the oven door from the range and place it face down on a soft surface.

2. Remove the (20) screws, four on each side,

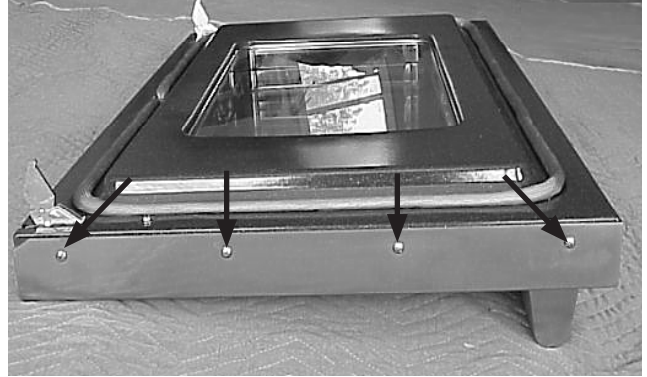

six on the top and six on the bottom,



holding the outer panels to the inner panel and lift the outer door panel package off.

Removing door handle studs:

1. Remove the outer door panel assembly.
2. Using (2), 10 mm wrenches, one to hold a stud and one to remove the nut, remove the nut and lift the stud off.

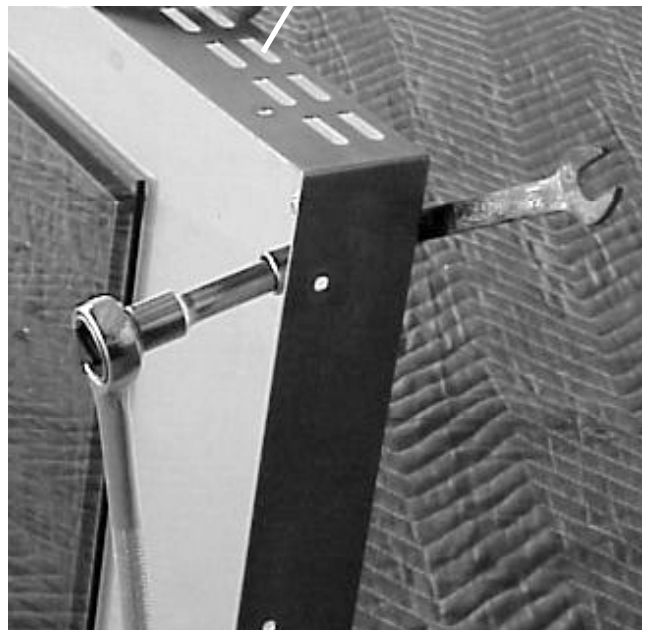

Removing the door hinges:

1. Remove the outer door panel assembly.
2. Remove the (2) screws holding the hinge to the inner door liner and slide the hinge out.

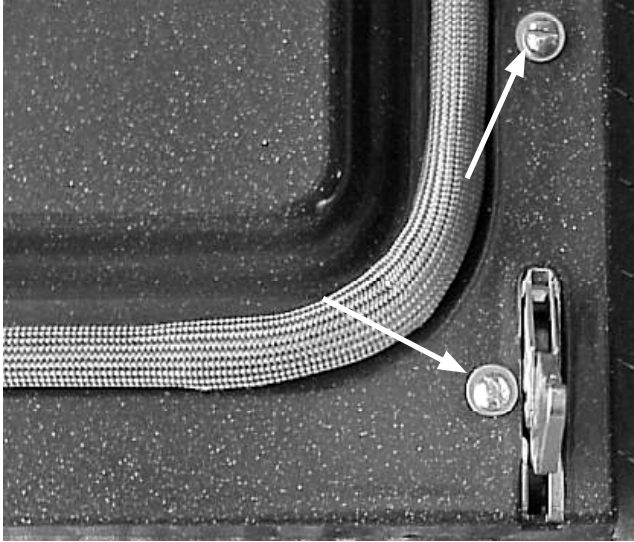

2. The glass package will lift out.



Removing door insulation:

1. Remove the outer door panel assembly and the installation cover plate.
2. The insulation will lift out.



Removing insulation cover plate:

1. Remove the outer door panel assembly.
2. Remove the (6) screws, one on each side and two at the top and the bottom, and lift the insulation cover plate off.



Removing door glass package:

1. Remove the outer door panel assembly and the installation cover plate.

Removing oven rack glides:

1. Remove the oven racks and lift up and out on the glides.

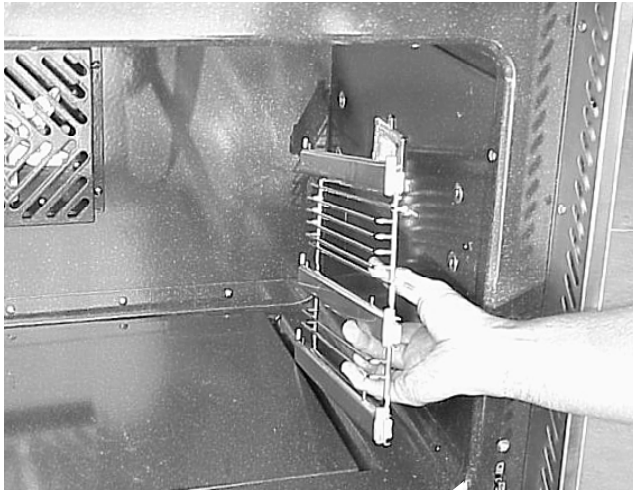

2. Pull out on the tab on the top of the light and lift the light out.



Removing oven bottom:

1. To remove the oven bottom lift the oven bottom up and out.



Removing bake burner baffle:

1. Remove the oven bottom.
2. Remove the (2) screws, holding the baffle to the bracket at the rear of the oven, lift the rear of the baffle up and slide it back to disengage the front oven frame.

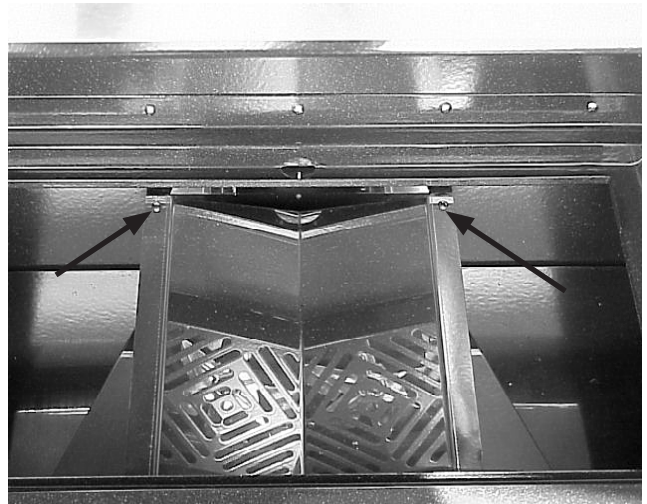

Removing oven lights:

1. Remove the oven racks and glide.

Removing the convection fan cover:

1. Remove the oven racks.

- Remove the (4) screws holding the fan cover to the rear wall of the oven and lift the cover off.

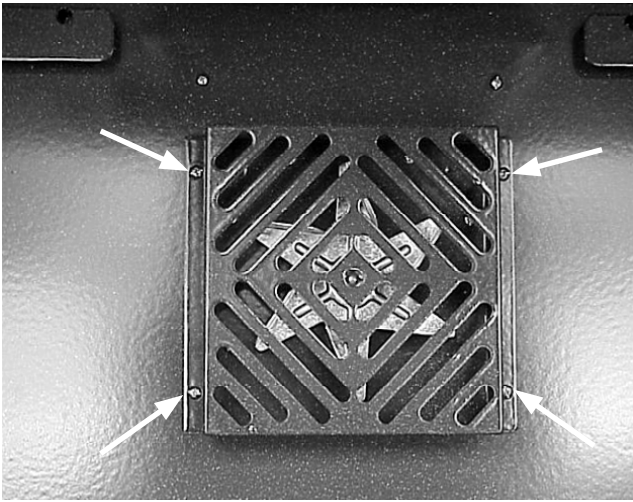

- Remove the (8) screws holding the insulation cover to the rear wall of the oven.

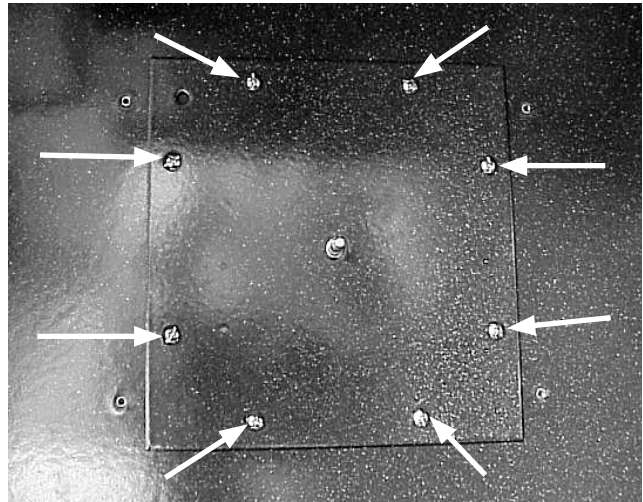

Removing the convection fan blade:

- Remove the oven racks and convection fan cover.
- Using a 13 mm wrench or socket, turn the nut clockwise while holding the fan blade.

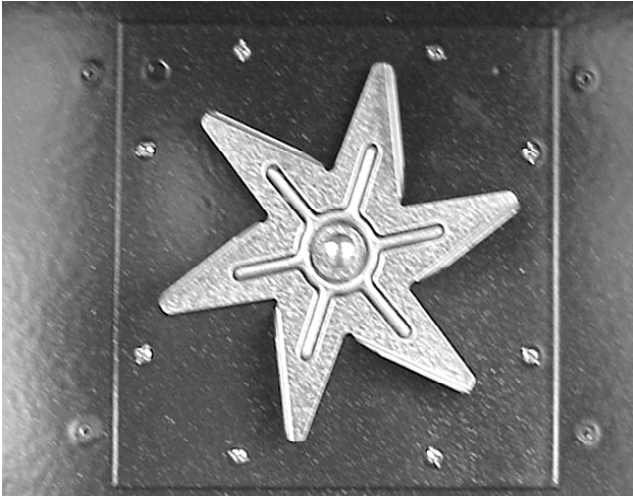

- With the nut removed the fan blade will pull straight off.

Removing the convection fan insulation cover:

- Remove the convection fan blade.

Removing the convection fan motor and mounting bracket:

- Disconnect power from a range and remove the convection fan insulation cover.

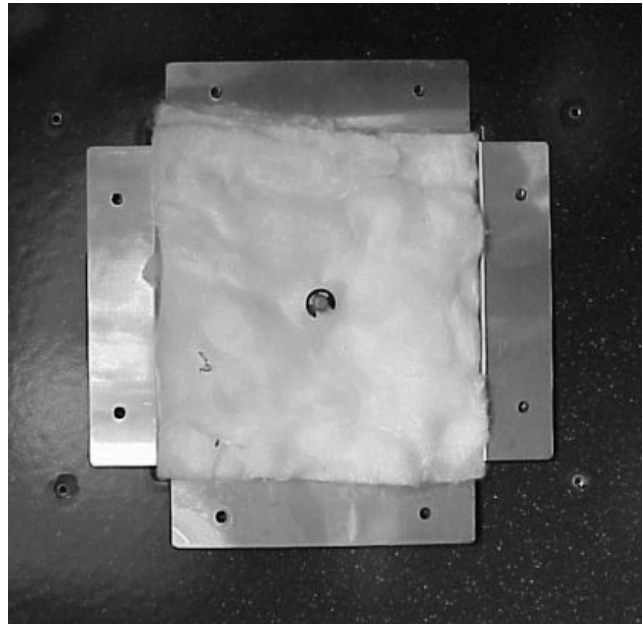

2. Pull the motor and mounting bracket into the oven and disconnect the wires to the motor.

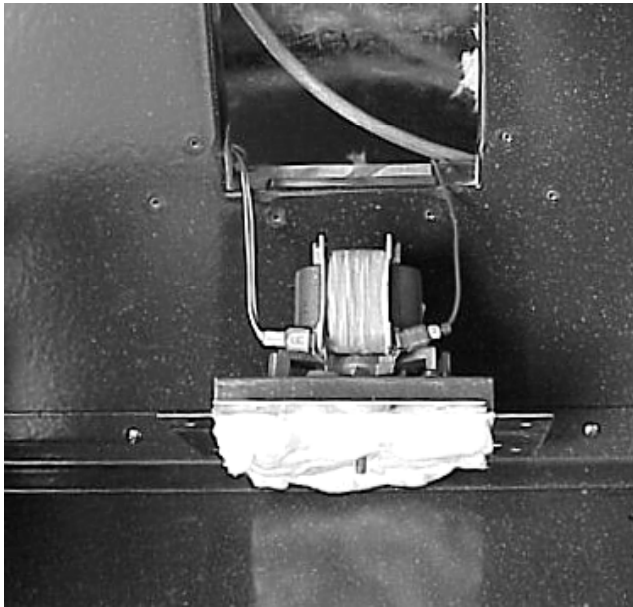

Removing the convection fan motor from the mounting bracket:

1. Disconnect power from the range, remove the fan motor and mounting bracket.
2. Remove the (7) screws holding the motor to the mounting bracket and lift the motor off.

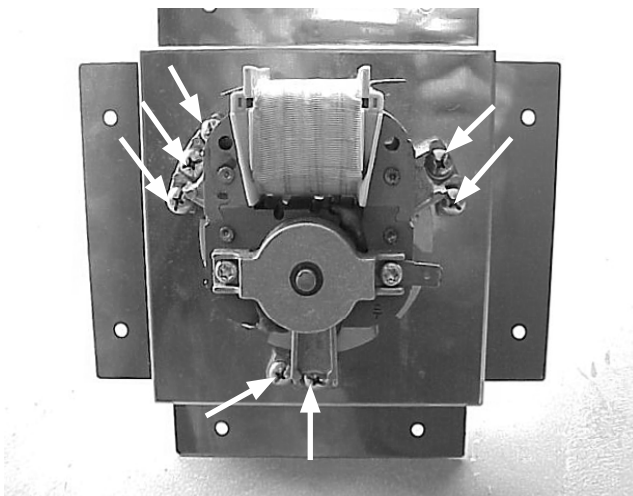

Removing the rear panel:

1. Disconnect power from the range, gain access to the rear of the range and remove the backguard.

2. Remove the (6) screws, three on each side, holding the rear panel to the range and lift the panel off.

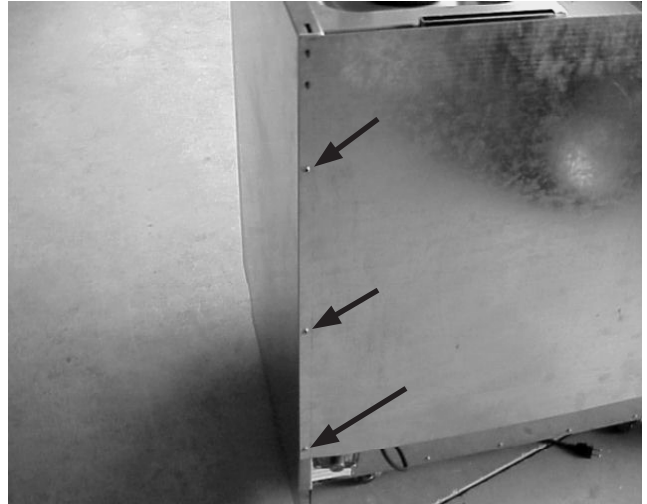

Removing the pressure regulator:

1. Turn the gas off and remove power from the range.
2. Remove the rear panel from the range and disconnect the gas line to the range.
3. Using the pair of channel locks turn the pressure regulator clockwise to disconnect it from a manifold pipe.

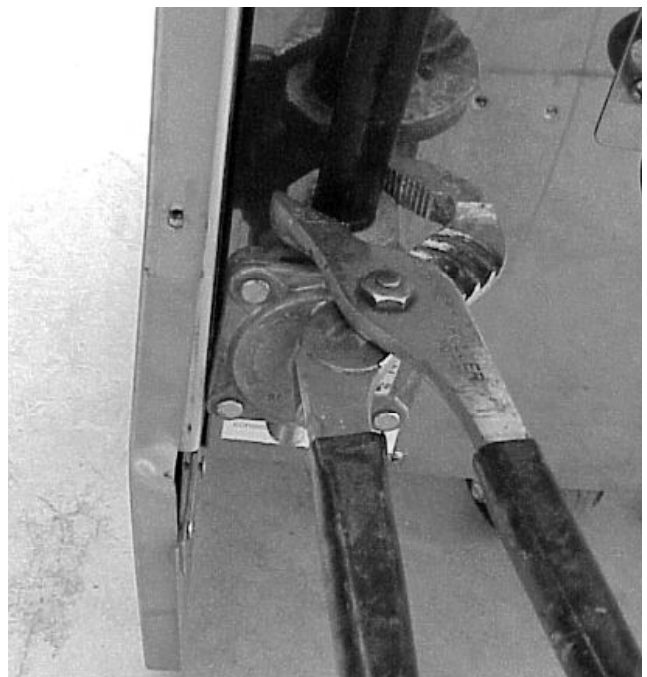

Removing the top burner igniter module:

1. Disconnect power from the range, and remove the rear panel.
2. Disconnect the wires from the module, remove the (3) screws holding the module to the rear of the range and lift the module off.

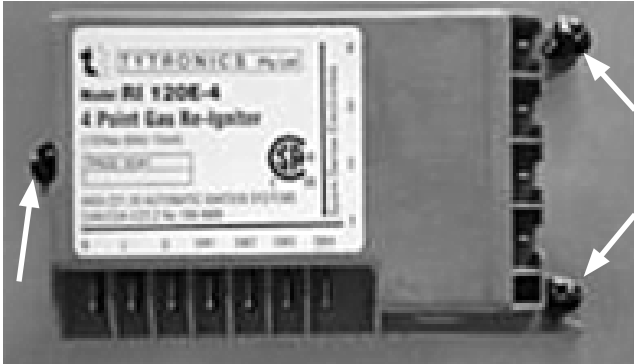

2. Remove the (2) screws holding the bracket to the rear of the range and lift the bracket out.

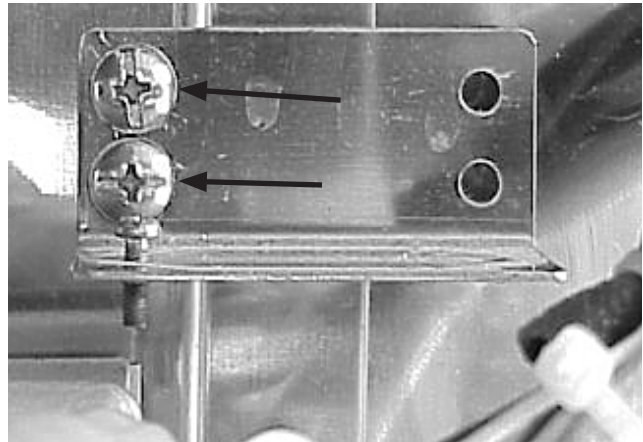

Removing the convection fan relay:

1. Disconnect power from the range, and remove the rear panel.
2. Disconnect the wires from the relay, remove the (1) screw and loosen the other holding the relay to the relay mounting bracket and slide the relay out from under the loosened screw and lift the relay out.

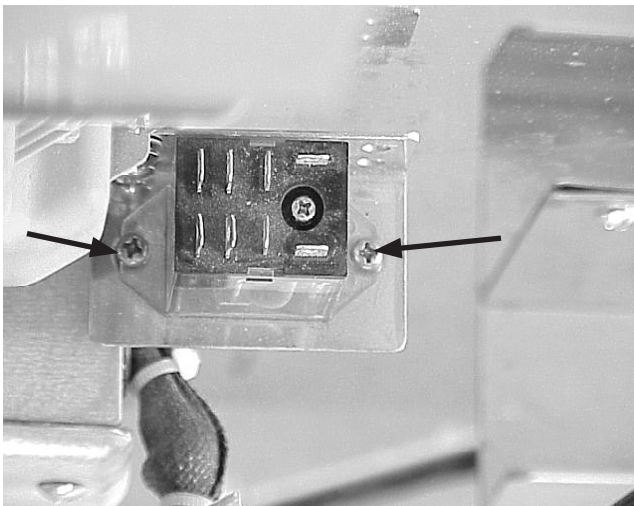

Removing the broiler orifice shield:

1. Disconnect power from the range, and remove rear panel.
2. Remove the (4) screws holding the shield to the back of the range.

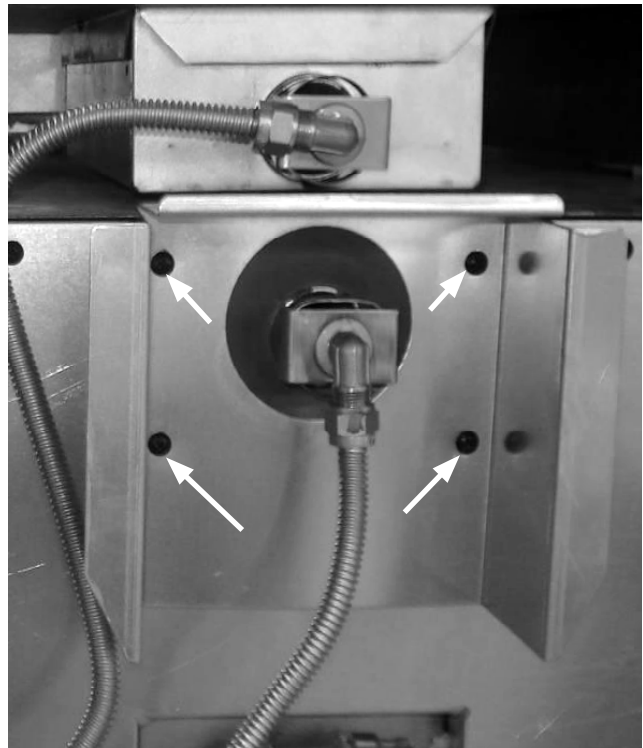

Removing the convection fan relay mounting bracket:

1. Disconnect power from the range, and remove the relay.

Removing the broiler burner seal:

1. Disconnect power from the range and remove broiler burner seal cover.

- Carefully pull the seal over the orifice assembly.

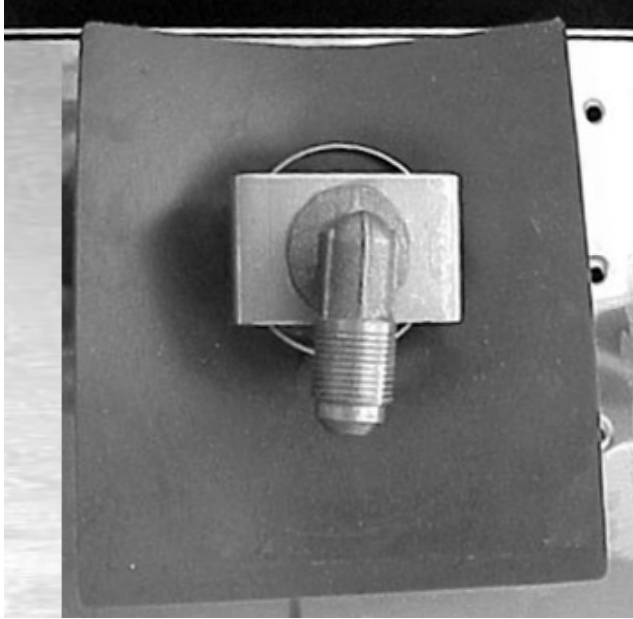

Removing the broiler orifice assembly:

- Disconnect power from the range, remove the rear panel from the range and disconnect the flex gas line from the orifice assembly.
- While holding the locking nut with a pair of needle nose pliers, turn the orifice assembly counterclockwise.

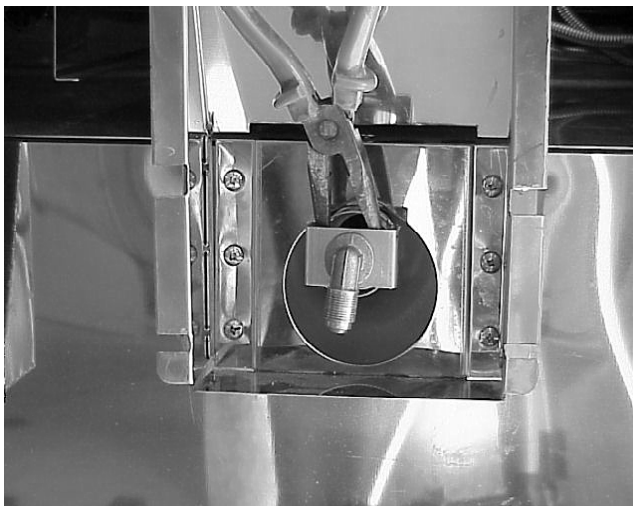

Removing the oven vent:

- Disconnect power from the range, remove the backguard, and rear panel.

- Remove the (2) screws holding the oven vent to the top brace and lift vent out.

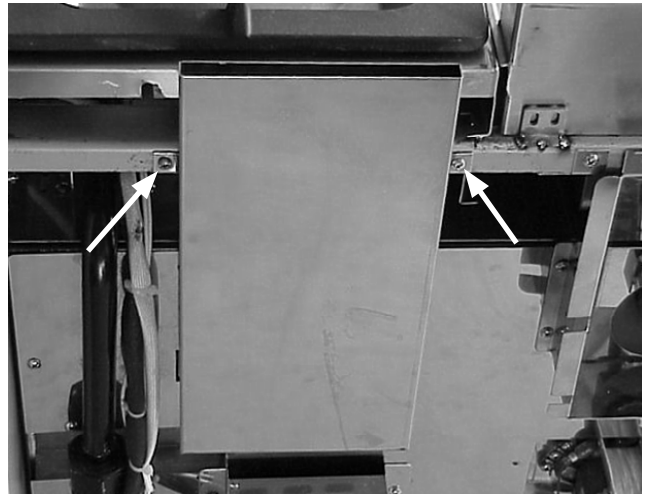

Removing the flexible tubing between the broiler valve in the broiler orifice:

- Disconnect power from the range, and remove rear panel.
- Using a 5/8 inch wrench disconnect the tubing from the orifice assembly and the broiler safety valve.

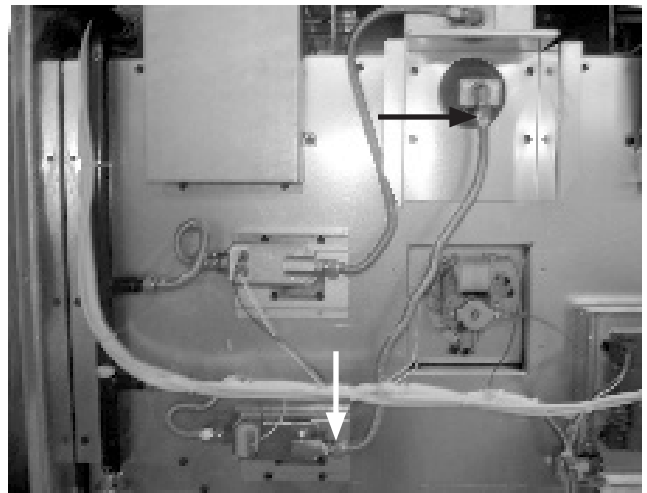

Removing the broiler safety valve:

- Disconnect power from the range, and remove rear panel.

2. Disconnect the wiring, and the incoming and outgoing tubing from the safety valve.

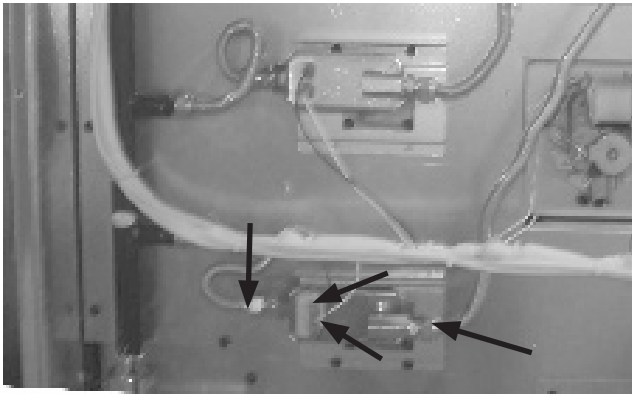

3. Remove the (2) screws locking the broiler safety valve to the broiler safety valve mounting bracket and slide the valve out of the bracket.

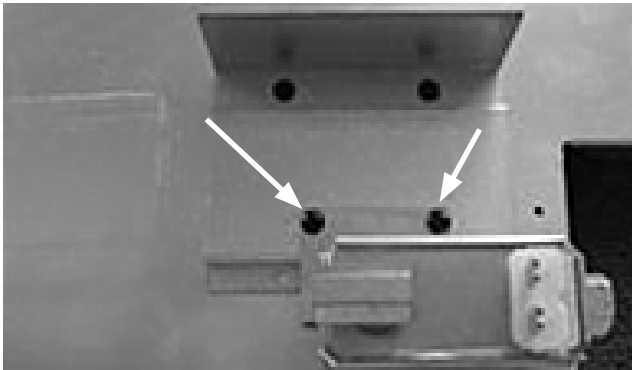

Removing the broiler safety valve mounting bracket:

1. Disconnect power from the range, and remove broiler safety valve.
2. Remove the two screws holding the bracket to the rear wall of the range and lift the bracket off.

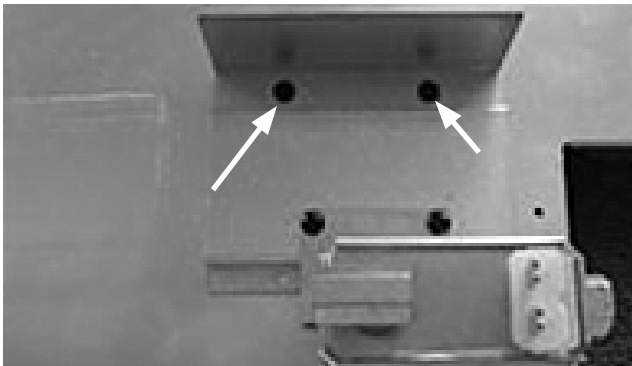

Removing the broiler burner igniter:

1. Disconnect power from the range, release the control panel and remove the oven racks.
2. Disconnect the (2) wires going to the broiler igniter.

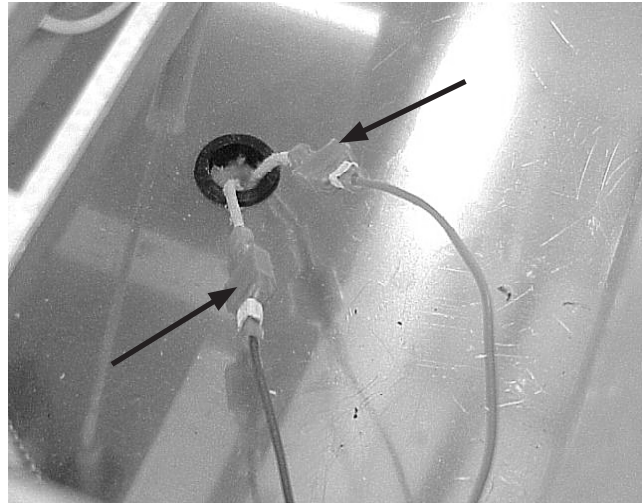

3. Pull wires down through the ceramic block into the oven.

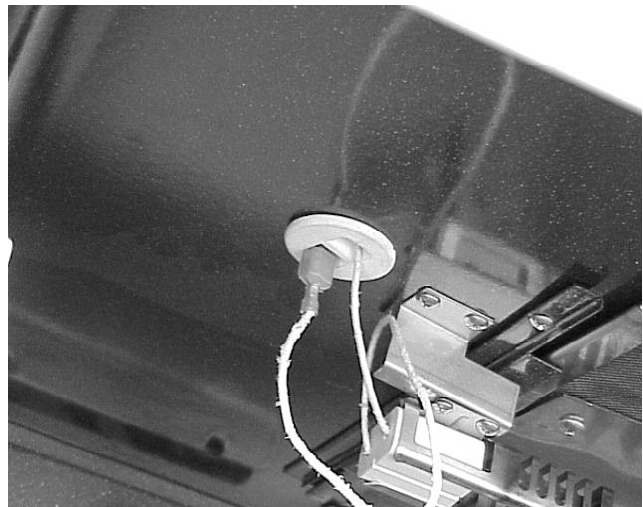

4. Remove the (2) screws holding the igniter to the bracket and lift the igniter out.

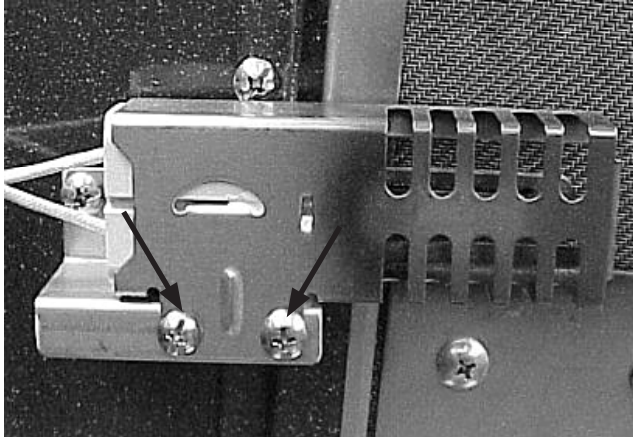

2. Remove the (2) screws holding the bracket to the oven liner and the bracket will drop down.

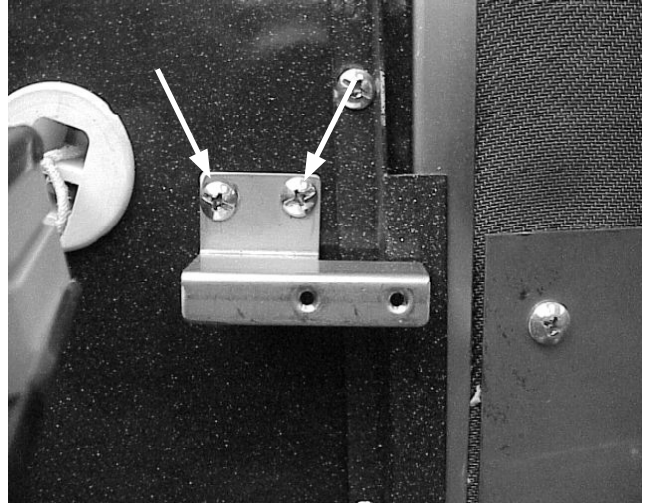

5. When reinstalling the igniter use a common screwdriver with a small blade, inserted into the bottom of the wire terminals, to guide the wires through the ceramic block and up through the installation.

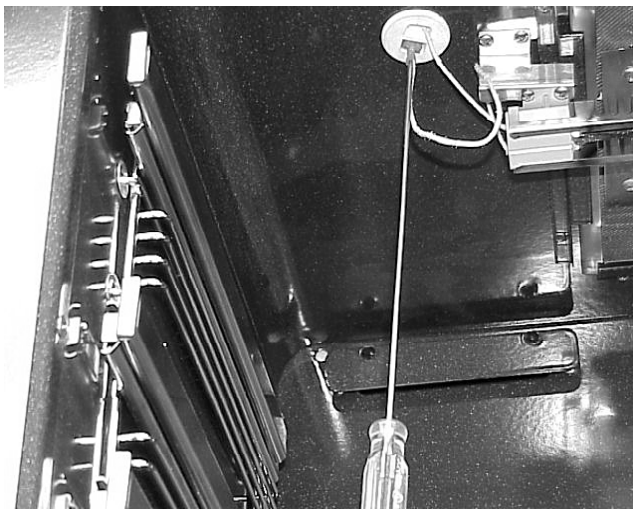

Removing the broiler burner:

1. Disconnect power from the range, remove the rear panel, drop the broiler igniter down and remove the broiler igniter bracket.
2. Disconnect the broiler orifice assembly from the broiler burner.
3. Remove the (10) screws, three on each side, two in the front and two in the rear, holding the broiler brackets in place.

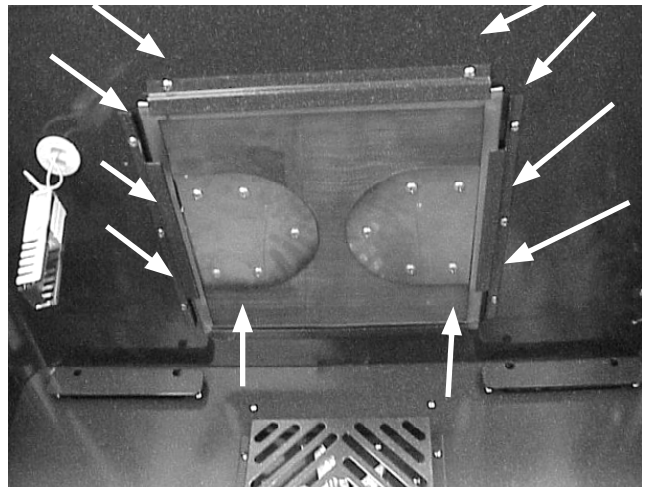

Removing the broiler igniter mounting bracket:

1. Disconnect power from the range, remove the oven racks and drop igniter down.

4. Let the front of the broiler burner drop-down and pull the burner forward and out of the oven.

Removing the oven vent covers:

1. Remove the oven racks.

2. Remove the (2) screws holding the vent cover to the rear wall of the oven and the cover will drop down.

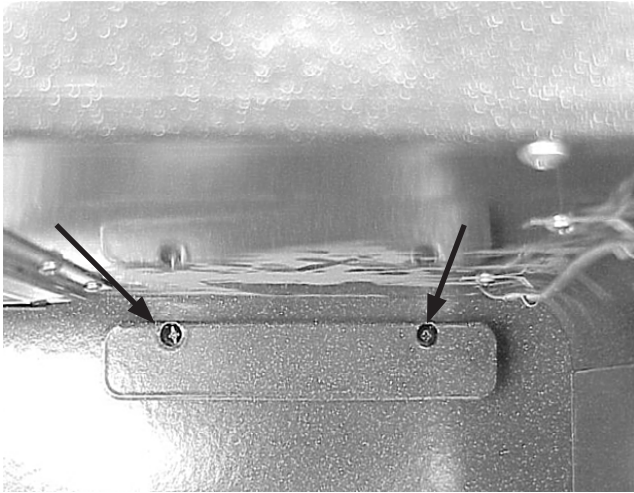

3. Pull out on the bottom of the panel and lift up to disengage the panel from the (2) shoulder bolts, one in each side trim.



Removing the kick panel:

1. Disconnect power and remove the oven of door.
2. Remove the (2) screws holding the kick panel to the range frame.



Removing the bake burner safety valve:

1. Disconnect power, turn the gas off to the oven and remove the kickplate.
2. Disconnect the wires to the safety valve, and using a 5/8" wrench, disconnect the input and output gas tubing.

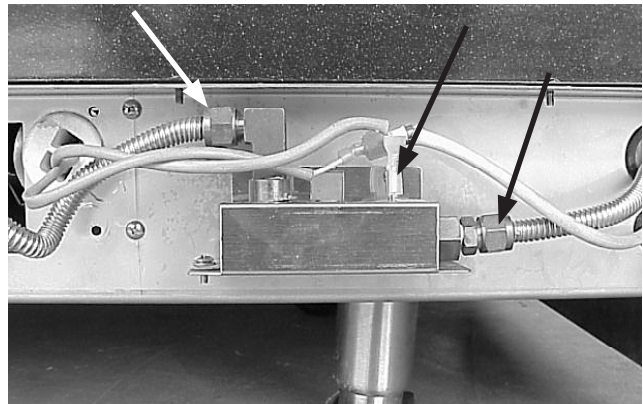

3. Remove the screw holding the valve to the valve mounting bracket and slide the valve out.

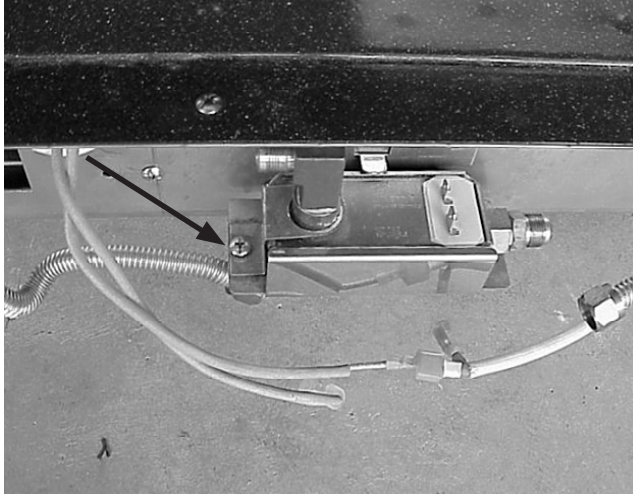

2. Using a 5/8" wrench disconnect the flexible gas line from the orifice assembly.

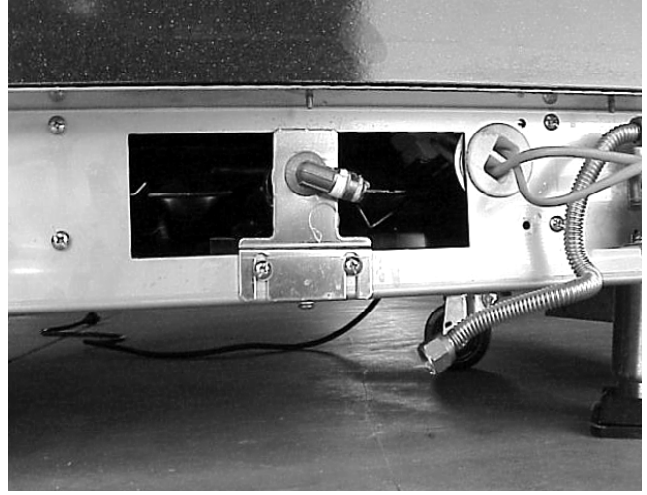

Removing the bake burner safety valve mounting bracket:

1. Disconnect power, turn the gas off to the oven and remove the kickplate.
2. Remove the bake burner safety valve from its bracket.
3. Remove the (2) screws holding the bracket to the front panel and lift the bracket off.

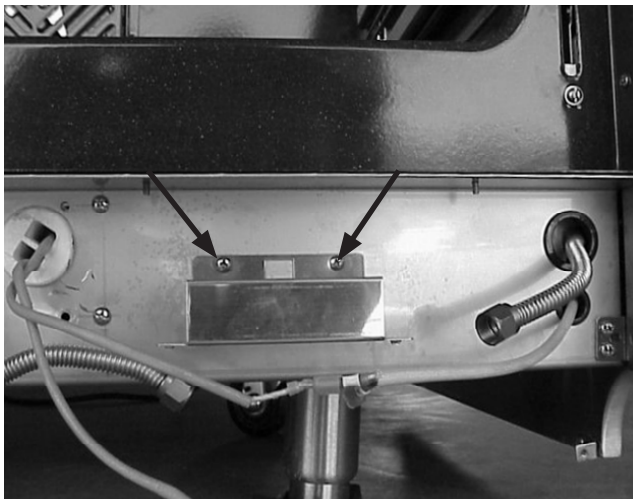

3. Remove the (2) screws holding the orifice assembly mounting bracket to the front panel and pull the orifice assembly out.

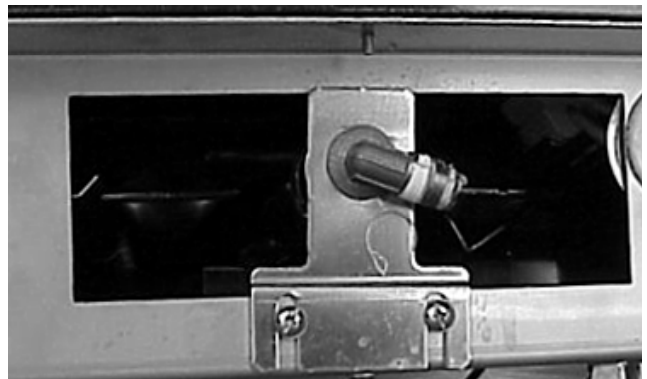

Note: When reinstalling the orifice assembly adjust the orifice assembly so that the bake burner is level.

Removing the bake burner orifice:

1. Disconnect power, and remove the kickplate.
2. Remove the orifice assembly and mounting bracket.

Removing the bake burner orifice assembly and mounting bracket:

1. Disconnect power, turn the gas off to the oven and remove the kickplate.

- Using a 10 mm wrench, turn the orifice counterclockwise.



- Remove the (2) screws holding the igniter to the bake burner and pull the igniter and wires into the oven cavity.



Removing the bake burner igniter:

- Disconnect power, and remove the kickplate.
- Disconnect the wires to the igniter.

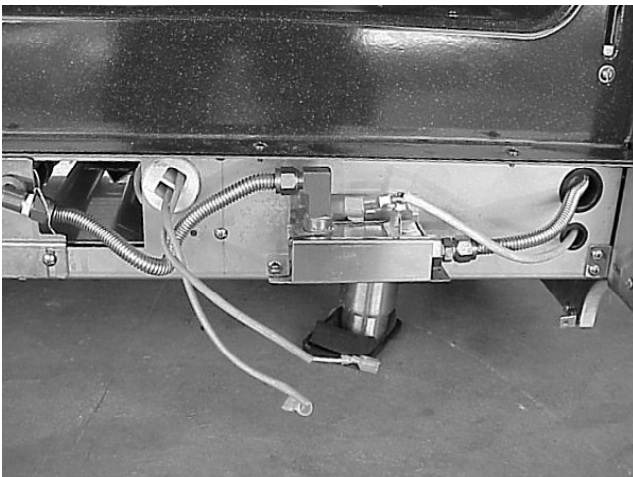

- Remove the oven bottom and the bake burner baffle.

Removing the bake burner:

- Remove the oven bottom, bake burner baffle and bake burner igniter.
- Remove the screw holding the rear of the bake burner to the burner mounting bracket and lift the burner out.

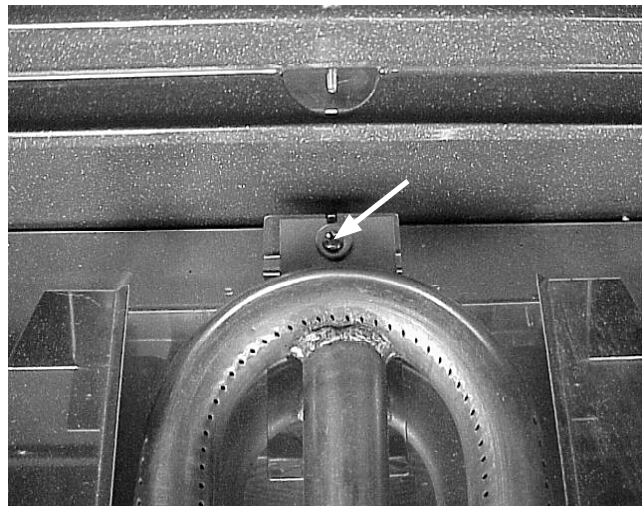

Removing the bake burner igniter ceramic wire guide:

- Disconnect power, and remove the kickplate.
- Remove the bake burner and igniter.

3. Use in a small common screwdriver remove the large C clamp and pull the ceramic block out the front.

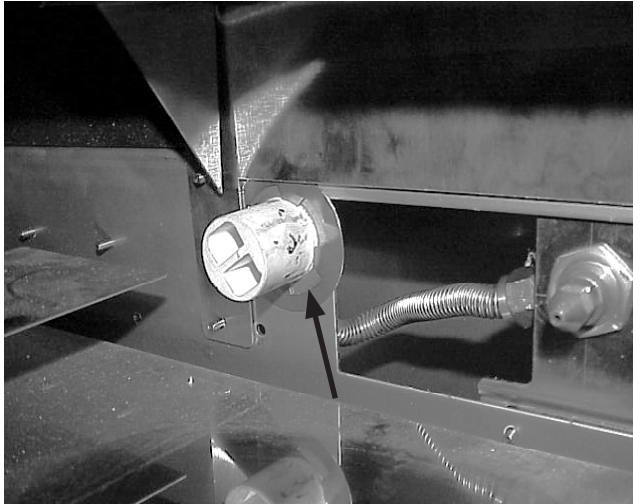

Removing the bake burner mounting bracket:

1. Remove the bake burner.
2. Remove the (2) screws holding the burner mounting bracket to the range base.

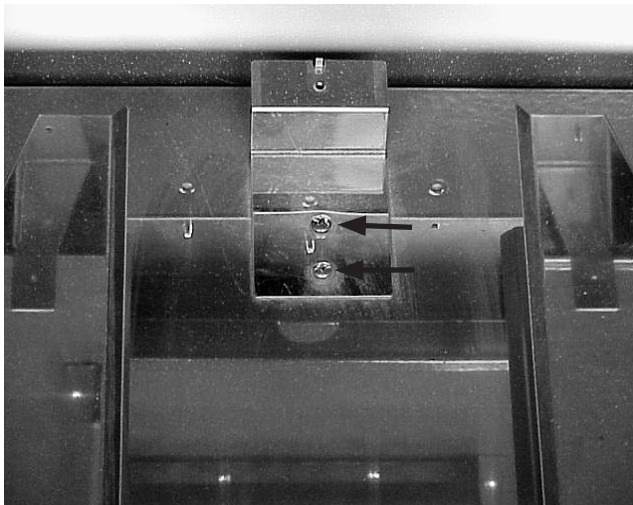

Removing the bake burner side baffles:

1. Remove the oven bottom and bake burner baffle.

2. Remove the (2) screws holding the side baffle to the range base and lift the baffle out.

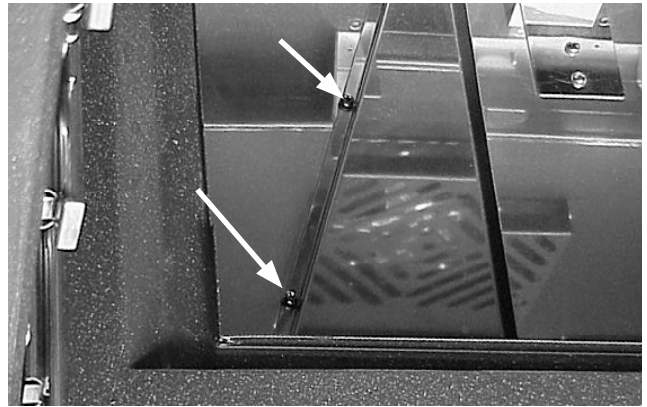

Removing the side panel front trims:

1. Remove the oven door and kickplate.
2. Remove the (4) screws holding the trim to the oven liner frame and (2) screws holding the trim to the bottom bracket.

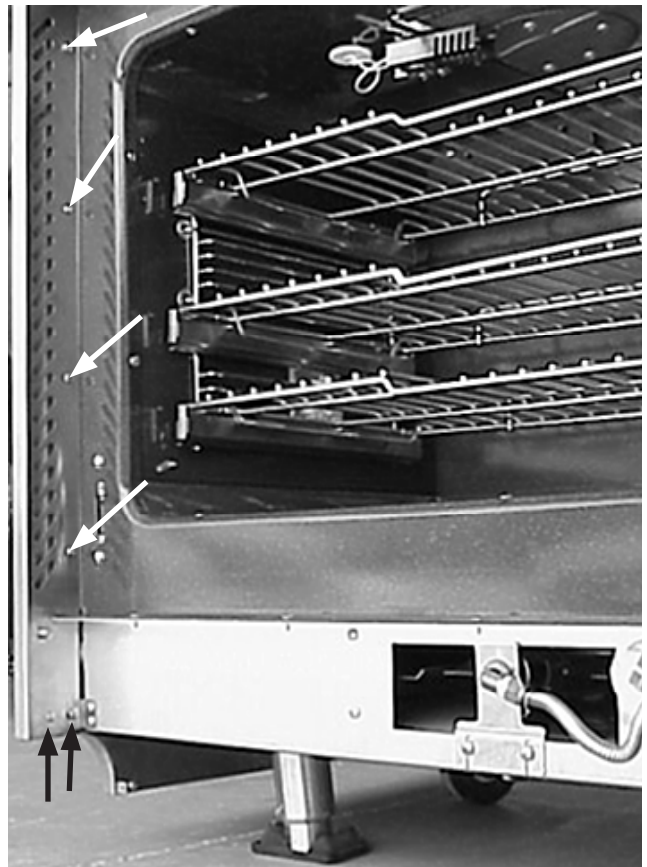

3. Pull down on the trim, to disengages the (2) shoulder bolts, and lift the trim off.

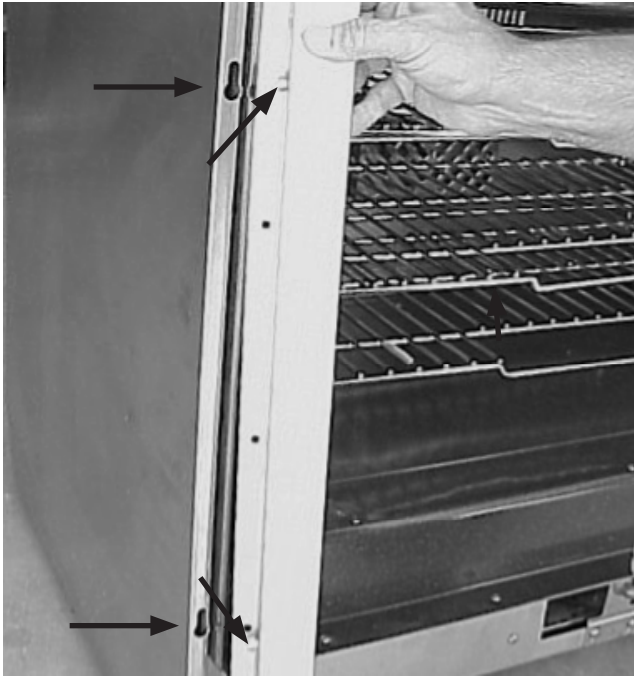

Removing the body side front trim bottom bracket:

1. Disconnect power, and remove the body side front trim.
2. Remove the (2) screws hold in the bracket to the lower front panel and lift the bracket off.

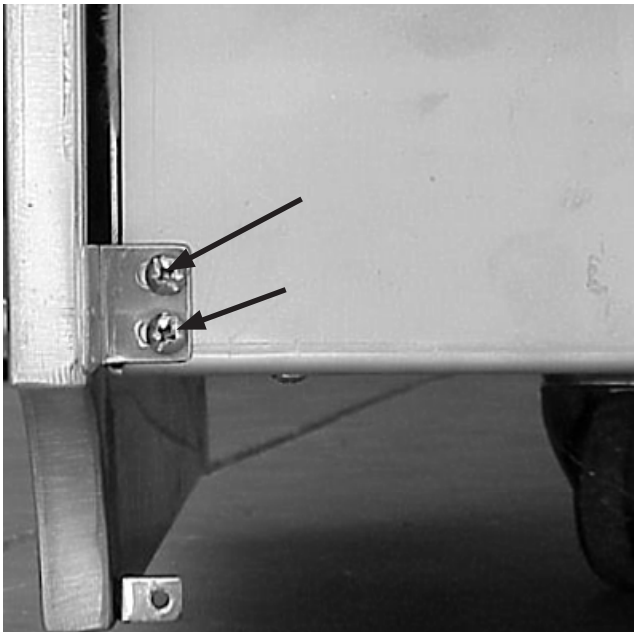

Removing the body side:

1. Disconnect power, remove the control panel trim, and the body side front trim.
2. Remove the backguard and rear panel.
3. Remove the (2) screws holding the body side to the rear bracket and lift the body side off.

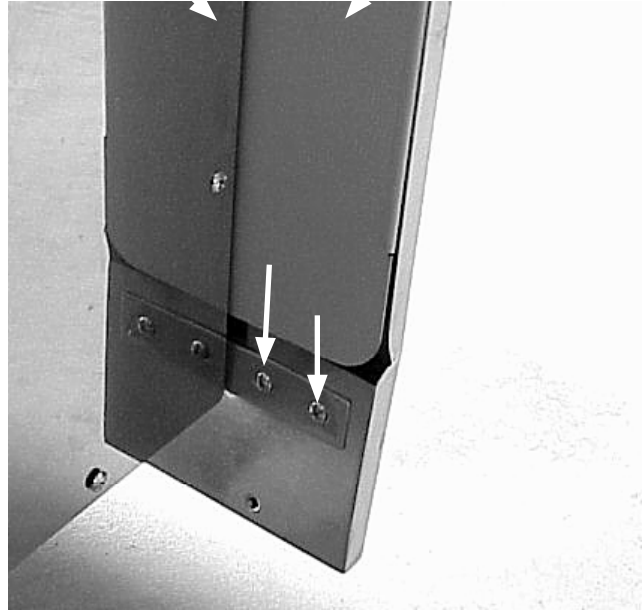

Removing the insulation side panels:

1. Disconnect power, and remove the side panel.

2. Remove the (24) screws holding insulation panel to the side of the range.

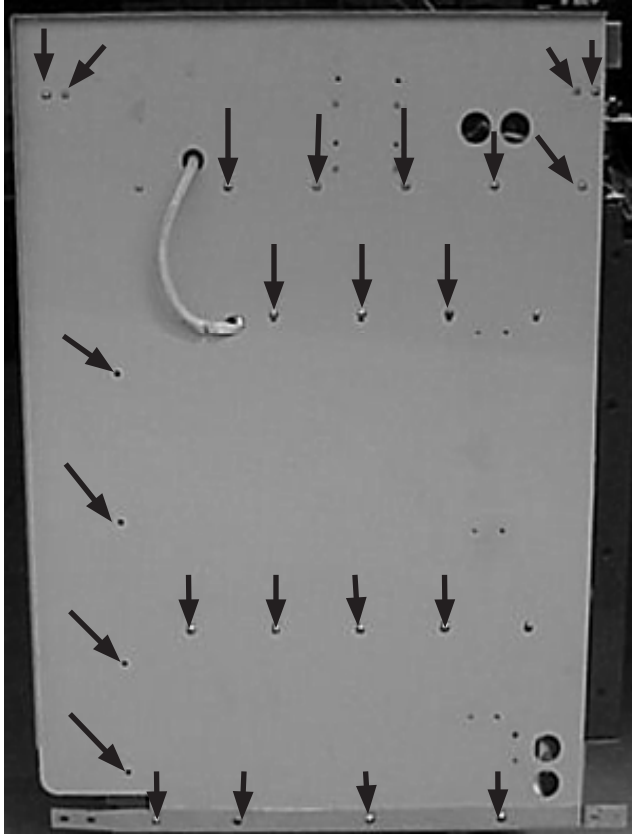

3. Lift the panel out, disconnect the wires to the oven light, pull the wire harness out of the installation panel and lift the panel off.

Removing the door hinge guides:

1. Disconnect power, and remove the insulation side panel.

2. Remove the (2) screws holding the hinge guides to the front of the oven



and lift the hinge guide out.



Removing the griddle orifice assembly: (36 inch models with built-in griddle)

1. Disconnect power, and remove the rear panel from the range.

- Using an adjustable wrench, disconnect the gas tubing from the orifice assembly.

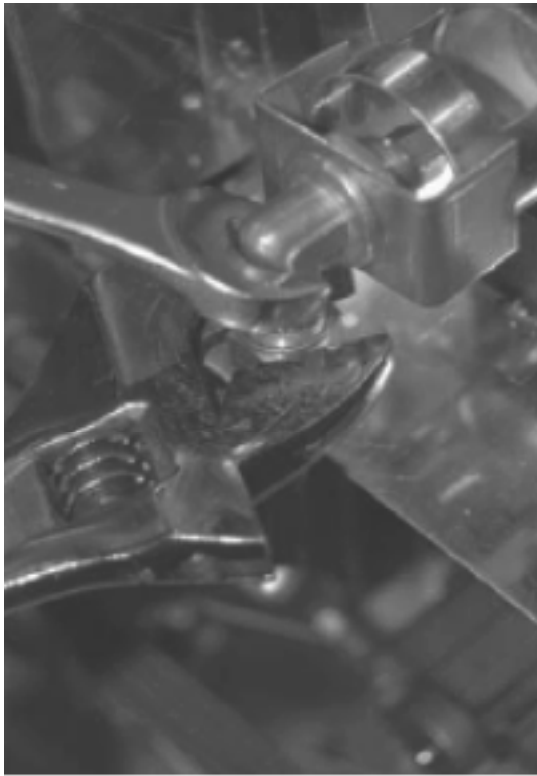

- Turn the orifice assembly counterclockwise while holding a locking nut with a pair of needle nose pliers.

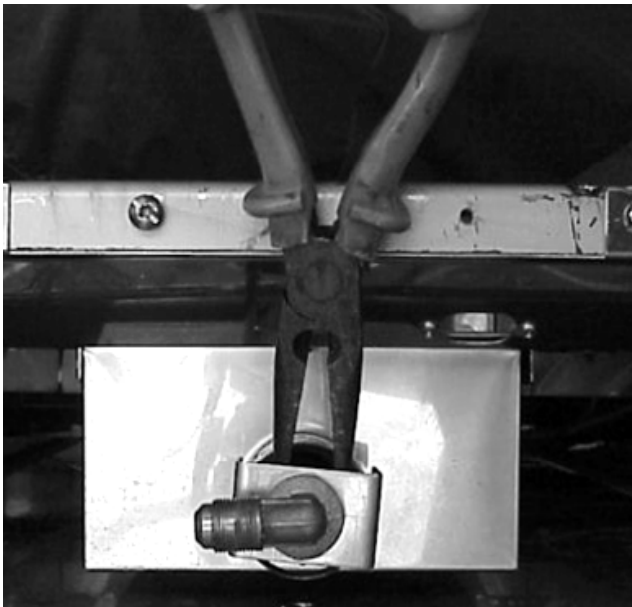

Removing the griddle orifice: (36 inch models with built-in griddle)

- Disconnect power, and remove the griddle orifice assembly.
- Using a 10 mm wrench remove the orifice from the orifice assembly.

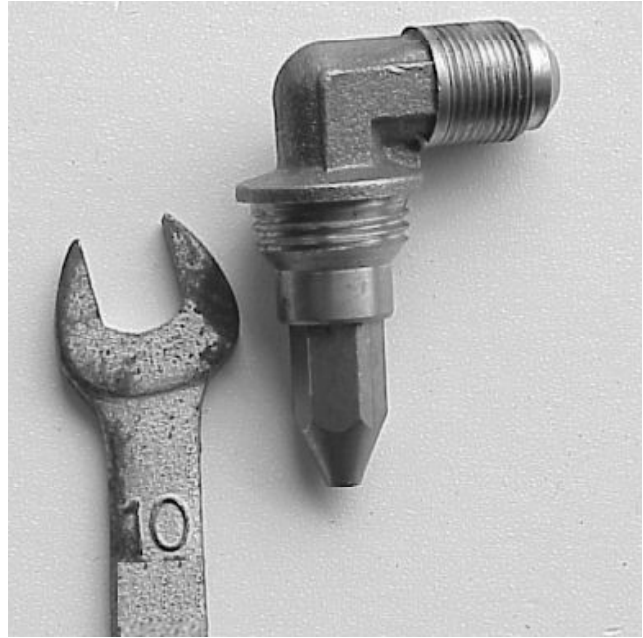

Removing the griddle igniter:

- Disconnect power, remove the griddle and the left-hand drip pan.
- Disconnect the (2) wires to the igniter.

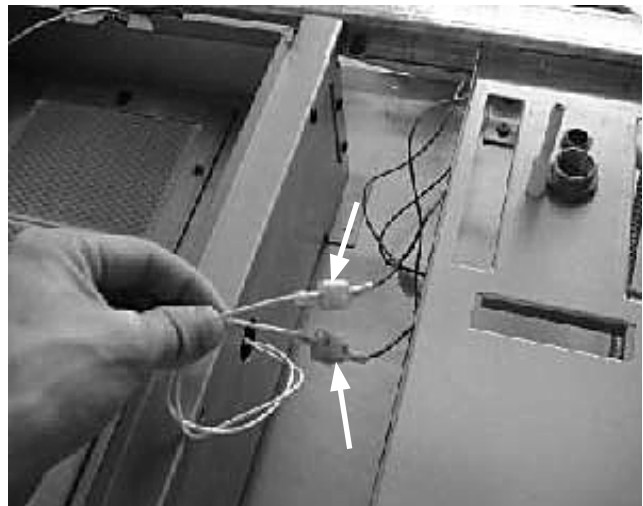

3. Removed the screw holding the igniter to igniter bracket and pull the igniter out.



2. Remove the screw holding the burner to the frame assembly.

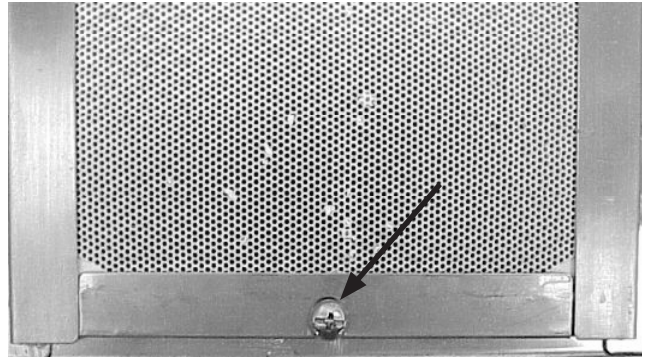

3. Lift up on the front of the burner until it clears the frame assembly, then pull the burner forward and lift it out.

Removing the griddle igniter bracket:

1. Disconnect power, and remove the griddle igniter.
2. Remove the (3) screws holding the igniter bracket to the wall of the griddle burner frame and lift the bracket out.

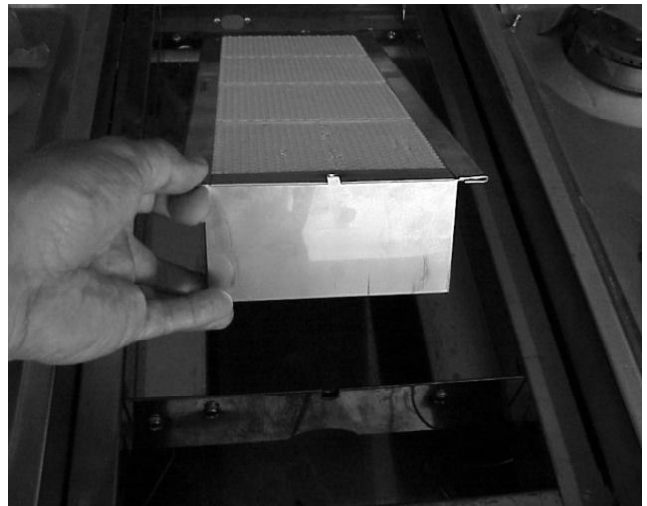
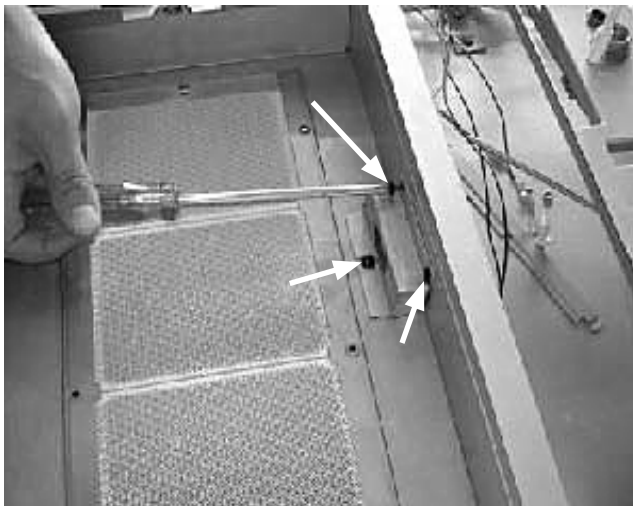

Removing the center divider: (30 inch models)

1. Disconnect power, remove the backguard.

Removing the griddle burner:

1. Disconnect power, remove the griddle igniter and disconnect the gas line to the griddle orifice assembly.

2. Lift the rear of the divider up and pull it out.



Removing the drip pans:

1. Disconnect power, and remove the backguard.
2. Remove the center divider or griddle depending on the model.
3. Pull the drip pan towards the rear of the range, then lift the side of the drip pan towards the center of the range until the pan clears the igniters and releases from the side panel.



4. Then lift the drip pan off.

Removing the oven thermostat:

1. Disconnect power, remove the right-hand drip pan and thermostat knob.

2. Release the thermostat bulb from the clips in the oven.

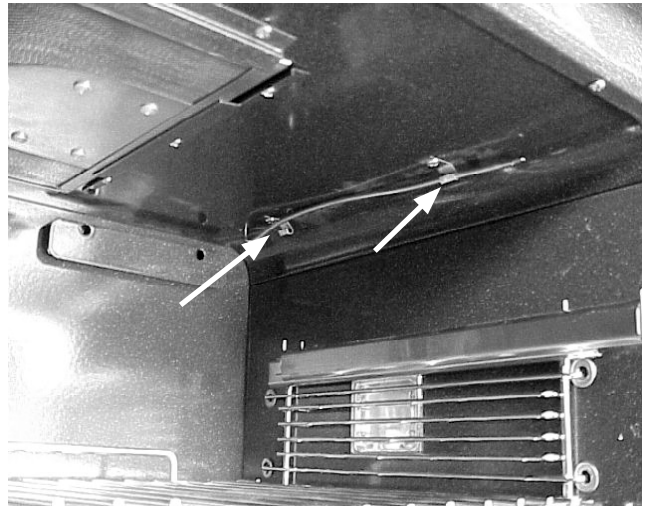

3. Pull the thermal bulb up into the burner box.

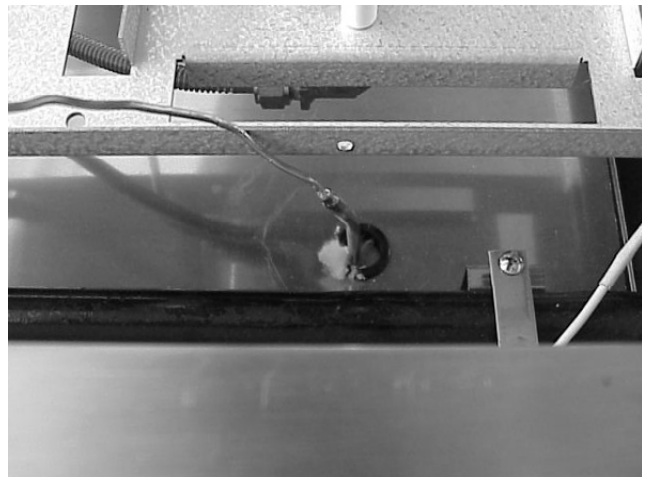

4. Disconnect the wires from the thermostat.

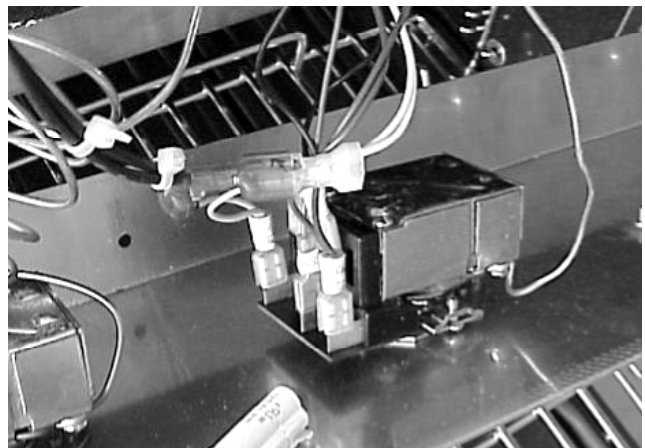

5. Remove the (2) screws holding the thermostat to the control panel and lift the thermostat out.

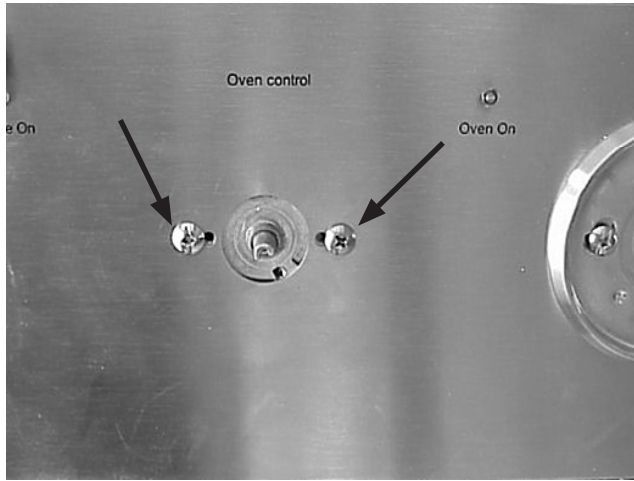

3. Using a 5/8" wrench release a locking nut and drop the orifice assembly down.

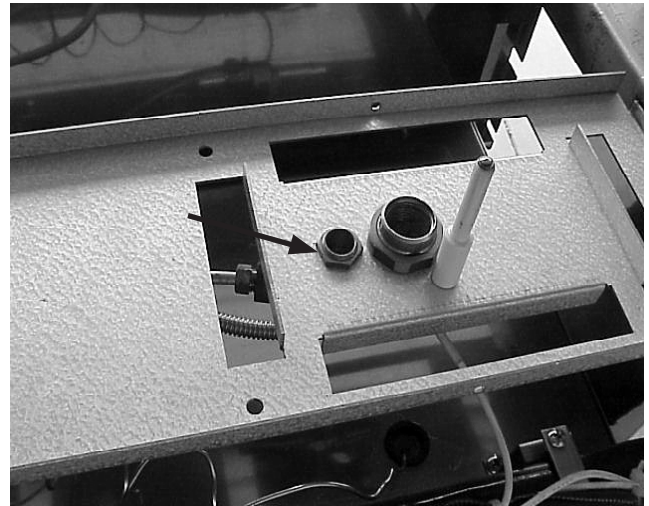

Removing the simmer burner orifice assembly:

1. Disconnect power, and remove the drip pan.
2. Using a 10 mm wrench disconnect the gas tube from the orifice assembly.

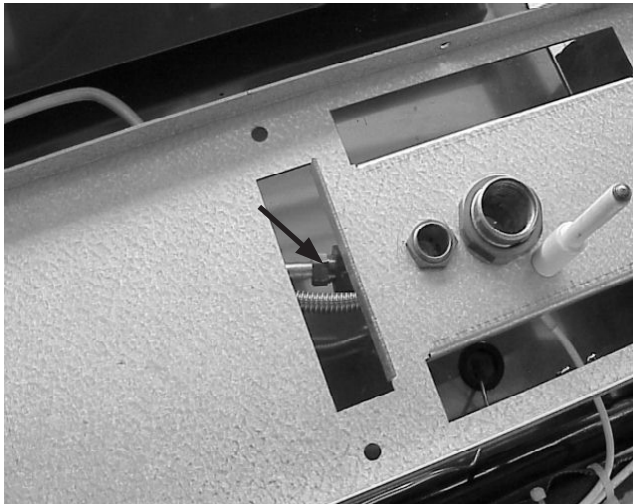

Removing the top burner orifice assembly:

1. Disconnect power, and remove the drip pan.
2. Using a 5/8" wrench disconnect the gas tube from the orifice assembly.

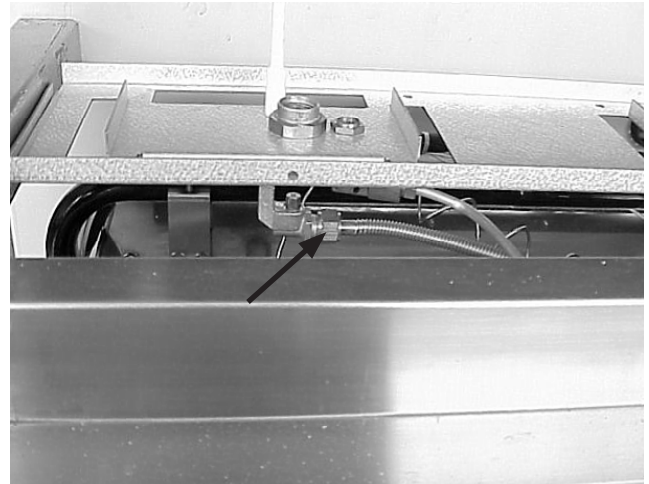

- Using a 1 1/16" wrench release, the locking nut and the orifice assembly will drop down.

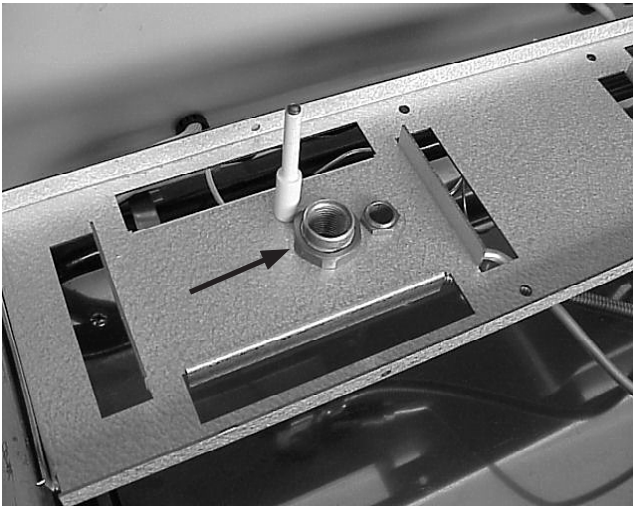

- Raise the front of the plate and pull a plate forward to disengage the two tabs in the back from the rear brace.



Releasing the top burner orifice mounting plate assembly:

- Disconnect power, and remove the drip pan.
- Remove the locking nuts on the burner orifice assemblies, and the simmer burner orifice assemblies and drop the assemblies down.
- Remove the (2) screws holding the mounting plate to the front brace.

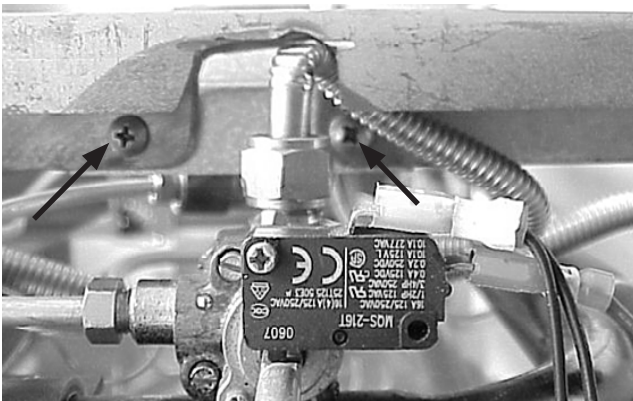

Removing the top burner igniter:

- Disconnect power, and release the top burner orifice mounting plate assembly.
- Disconnect the wire from the igniter.

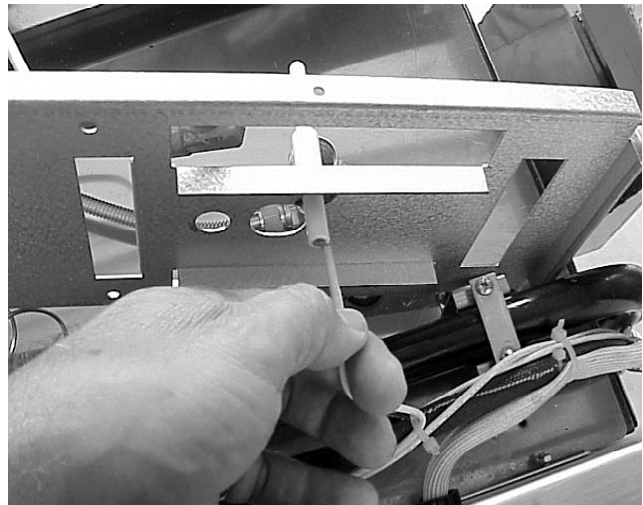

- Remove the C clamp locking the igniter to the mounting plate and lift the igniter out of the top.



- Remove the (8) screws, four on each side, holding the side wool shields to the main base.

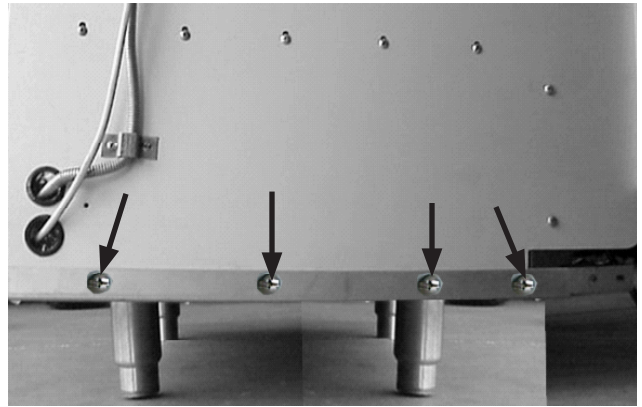

Removing the top burner orifice mounting plate assembly:

- Disconnect power, and remove the drip pan.
- Release the mounting plate assembly, remove the igniters and lift the mounting plate out.

Removing the main base:

- Disconnect power, remove the oven door, oven bottom, oven burner baffle and kickplate.
- Disconnect the gas line to the oven's safety valve and the wires from the oven igniter in the oven safety valve.
- Remove the rear panel and both body sides from the range.
- Remove the (6) screws holding the rear insulating shield to the main base.

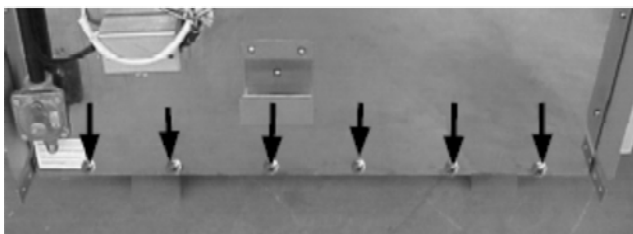

- Remove the (5) screws holding the main base to the front frame of the oven.

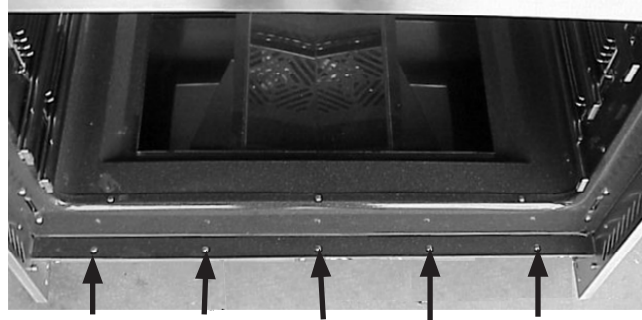

- Remove the (2) screws from the L. brackets one on each side, holding the main base insulation shield to the side of the oven frame.



8. Place the range on its back, remove the (15) screws holding the main base to the oven frame and lift the main base off.

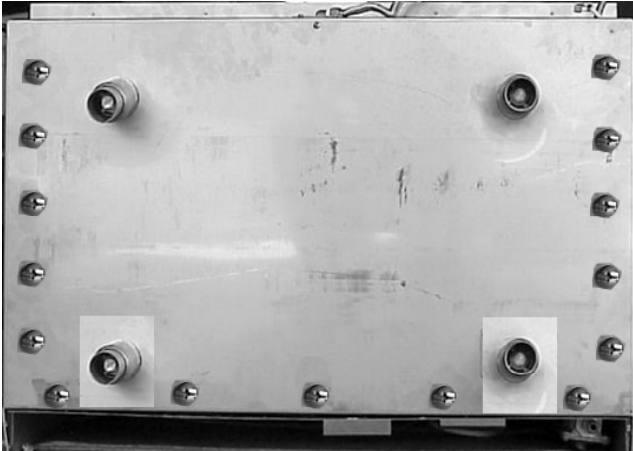

and lift the shield off.

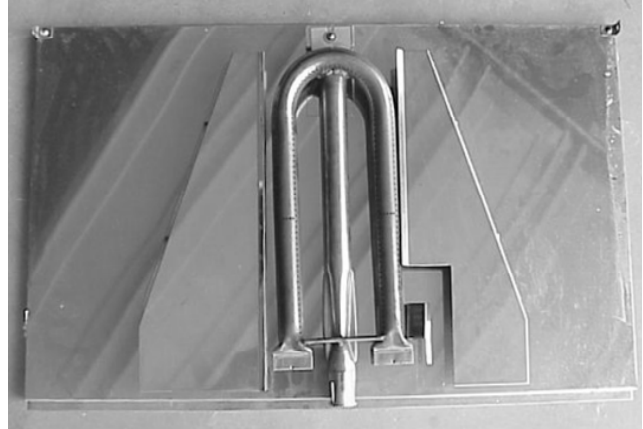

Removing the main base insulation shield:

1. Disconnect power and remove the main base.
2. Remove the screw holding insulation shield to the main base

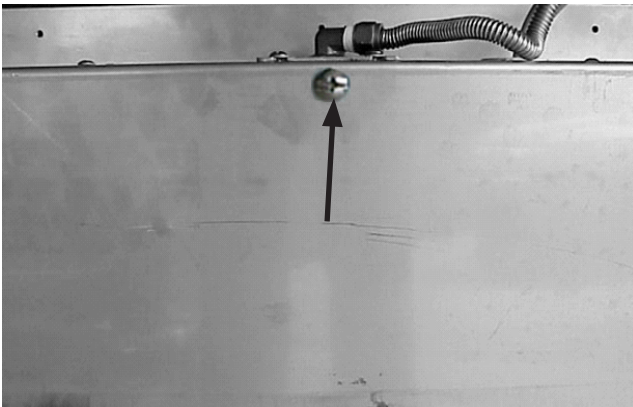

Removing the leveling legs:

1. Raise a range to take pressure off the leg.
2. Wrap the leg with a cloth to protect the finish, and use a pair of channel locks or pipe wrench to turn the upper part of the leg counterclockwise.

