

ELECTROLUX SERVICE MANUAL

S60M268E75FPS



HIGH SPEED CONVECTION MICROWAVE OVEN

MODEL

E30SO75FPSA

In the interest of user-safety the oven should be restored to its original condition and only parts identical to those specified should be used.

WARNING TO SERVICE PERSONNEL: Microwave ovens contain circuitry capable of producing very high voltage and current, contact with following parts may result in a severe, possibly fatal, electrical shock. (High Voltage Capacitor, High Voltage Power Transformer, Magnetron, High Voltage Rectifier Assembly, High Voltage Harness etc..)

TABLE OF CONTENTS

	Page
PRECAUTIONS TO BE OBSERVED BEFORE AND DURING SERVICE TO AVOID POSSIBLE EXPOSURE TO EXCESSIVE MICROWAVE ENERGY.....	INSIDE FRONT COVER
BEFORE SERVICING	INSIDE FRONT COVER
WARNING TO SERVICE PERSONNEL.....	3
MICROWAVE MEASUREMENT PROCEDURE.....	4
FOREWORD AND WARNING	5
PRODUCT SPECIFICATIONS	6
GENERAL INFORMATION.....	6
OPERATION.....	8
TROUBLESHOOTING GUIDE	15
TEST PROCEDURE	17
TOUCH CONTROL PANEL.....	28
PRECAUTIONS FOR USING LEAD-FREE SOLDER.....	32
COMPONENT REPLACEMENT AND ADJUSTMENT PROCEDURE.....	33
PICTORIAL DIAGRAM.....	41
POWER UNIT CIRCUIT	42
CPU UNIT CIRCUIT	43
PARTS LIST	44
PACKING AND ACCESSORIES	49

This document has been published to be used for after sales service only. The contents are subject to change without notice.

ELECTROLUX HOME PRODUCTS, INC.

P. O. Box 212378, Augusta, GA, 30917

800•944•9044

PRECAUTIONS TO BE OBSERVED BEFORE AND DURING SERVICING TO AVOID POSSIBLE EXPOSURE TO EXCESSIVE MICROWAVE ENERGY

- (a) Do not operate or allow the oven to be operated with the door open.
- (b) Make the following safety checks on all ovens to be serviced before activating the magnetron or other microwave source, and make repairs as necessary: (1) interlock operation, (2) proper door closing, (3) seal and sealing surfaces (arcing, wear, and other damage), (4) damage to or loosening of hinges and latches, (5) evidence of dropping or abuse.
- (c) Before turning on microwave power for any service test or inspection within the microwave generating compartments, check the magnetron, wave guide or transmission line, and cavity for proper alignment, integrity, and connections.
- (d) Any defective or misadjusted components in the interlock, monitor, door seal, and microwave generation and transmission systems shall be repaired, replaced, or adjusted by procedures described in this manual before the oven is released to the owner.
- (e) A microwave leakage check to verify compliance with the Federal Performance Standard should be performed on each oven prior to release to the owner.

BEFORE SERVICING

Before servicing an operative unit, perform a microwave emission check as per the Microwave Measurement Procedure outlined in this service manual.

If microwave emissions level is in excess of the specified limit, contact ELECTROLUX HOME PRODUCTS, INC. immediately.

If the unit operates with the door open, service person should 1) tell the user not to operate the oven and 2) contact ELECTROLUX HOME PRODUCTS, INC. and Food and Drug Administration's Center for Devices and Radiological Health immediately.

Service personnel should inform ELECTROLUX HOME PRODUCTS, INC. of any certified unit found with emissions in excess of $4\text{mW}/\text{cm}^2$. The owner of the unit should be instructed not to use the unit until the oven has been brought into compliance.

WARNING TO SERVICE PERSONNEL

Microwave ovens contain circuitry capable of producing very high voltage and current, contact with following parts may result in a severe, possibly fatal, electrical shock.

(Example)

High Voltage Capacitor, High Voltage Power Transformer, Magnetron, High Voltage Rectifier Assembly, High Voltage Harness etc..

Read the Service Manual carefully and follow all instructions.

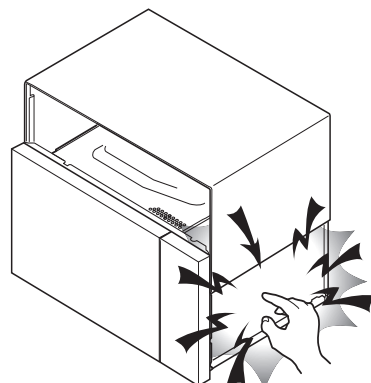

**Don't Touch !
Danger High Voltage**

Before Servicing



1. Disconnect the power supply cord, and then remove outer case.
2. Open the door and block it open.
3. Discharge high voltage capacitor.

**WARNING: RISK OF ELECTRIC SHOCK.
DISCHARGE THE HIGH-VOLTAGE
CAPACITOR BEFORE SERVICING.**

The high-voltage capacitor remains charged about 60 seconds after the oven has been switched off. Wait for 60 seconds and then short-circuit the connection of the high-voltage capacitor (that is the connecting lead of the high-voltage rectifier) against the chassis with the use of an insulated screwdriver.

Whenever troubleshooting is performed the power supply must be disconnected. It may, in some cases, be necessary to connect the power supply after the outer case has been removed, in this event,

1. Disconnect the power supply cord, and then remove outer case.
2. Open the door and block it open.
3. Discharge high voltage capacitor.
4. Disconnect the leads to the primary of the power transformer.
5. Ensure that the leads remain isolated from other components and oven chassis by using insulation tape.
6. After that procedure, reconnect the power supply cord.

When the testing is completed,

1. Disconnect the power supply cord, and then remove outer case.
2. Open the door and block it open.
3. Discharge high voltage capacitor.
4. Reconnect the leads to the primary of the power transformer.
5. Reinstall the outer case (cabinet).
6. Reconnect the power supply cord after the outer case is installed.
7. Run the oven and check all functions.

After repairing

1. Reconnect all leads removed from components during testing.
2. Reinstall the outer case (cabinet).
3. Reconnect the power supply cord after the outer case is installed.
4. Run the oven and check all functions.

Microwave ovens should not be run empty. To test for the presence of microwave energy within a cavity, place a cup of cold water on the oven turntable, close the door and set the power to HIGH and set the microwave timer for two (2) minutes. When the two minutes has elapsed (timer at zero) carefully check that the water is now hot. If the water remains cold carry out **Before Servicing** procedure and re-examine the connections to the component being tested.

When all service work is completed and the oven is fully assembled, the microwave power output should be checked and a microwave leakage test should be carried out.

MICROWAVE MEASUREMENT PROCEDURE

A. Requirements:

- 1) Microwave leakage limit (Power density limit): The power density of microwave radiation emitted by a microwave oven should not exceed $1\text{mW}/\text{cm}^2$ at any point 5cm or more from the external surface of the oven, measured prior to acquisition by a purchaser, and thereafter (through the useful life of the oven), $5\text{mW}/\text{cm}^2$ at any point 5cm or more from the external surface of the oven.
- 2) Safety interlock switches: Primary interlock relay and door sensing switch shall prevent microwave radiation emission in excess of the requirement as above mentioned, secondary interlock switch shall prevent microwave radiation emission in excess of $5\text{mW}/\text{cm}^2$ at any point 5cm or more from the external surface of the oven.

B. Preparation for testing:

Before beginning the actual measurement of leakage, proceed as follows:

- 1) Make sure that the actual instrument is operating normally as specified in its instruction booklet.

Important:

Survey instruments that comply with the requirement for instrumentation as prescribed by the performance standard for microwave ovens, 21 CFR 1030.10(c)(3)(i), must be used for testing.

- 2) Place the oven tray in the oven cavity.
- 3) Place the load of $275\pm 15\text{ ml}$ (9.8 oz) of tap water initially at $20\pm 5^\circ\text{C}$ (68°F) in the center of the oven cavity. The water container shall be a low form of 600 ml (20 oz) beaker with an inside diameter of approx. 8.5 cm (3-1/2 in.) and made of an electrically nonconductive material such as glass or plastic. The placing of this standard load in the oven is important not only to protect the oven, but also to insure that any leakage is measured accurately.
- 4) Set the cooking control on Full Power Cooking Mode.
- 5) Close the door and select a cook cycle of several minutes. If the water begins to boil before the survey is completed, replace it with 275 ml of cool water.

C. Leakage test:

Closed-door leakage test (microwave measurement)

- 1) Grasp the probe of the survey instrument and hold it perpendicular to the gap between the door and the body of the oven.
- 2) Move the probe slowly, not faster than 1 in./sec. (2.5 cm/sec.) along the gap, watching for the maximum indication on the meter.
- 3) Check for leakage at the door screen, sheet metal seams and other accessible positions where the continuity of the metal has been breached (eg., around the switches, indicator, and vents). While testing for leakage around the door pull the door away from the front of the oven as far as is permitted by the closed latch assembly.
- 4) Measure carefully at the point of highest leakage and make sure that the highest leakage is no greater than $4\text{mW}/\text{cm}^2$, and that the secondary interlock switch does turn the oven OFF before any door movement.

SERVICE MANUAL

ELECTROLUX

MICROWAVE OVEN

E30SO75FPSA

FOREWORD

This Manual has been prepared to provide Electrolux Home Products

Service Personnel with Operation and Service Information for the ELECTROLUX HIGH SPEED MICROWAVE OVEN, E30SO75FPSA.

It is recommended that service personnel carefully study the entire text of this manual so that they will be qualified to render satisfactory customer service.

Check the interlock switches and the door seal carefully. Special attention should be given to avoid electrical shock and microwave radiation hazard.

WARNING

Never operate the oven until the following points are ensured.

- (A) The door is tightly closed.
- (B) The door brackets and hinges are not defective.
- (C) The door packing is not damaged.
- (D) The door is not deformed or warped.
- (E) There is not any other visible damage with the oven.

Servicing and repair work must be carried out only by trained service personnel.

DANGER

Certain initial parts are intentionally not grounded and present a risk of electrical shock only during servicing. Service personnel - Do not contact the following parts while the appliance is energized;
High Voltage Capacitor, Power Transformer, Magnetron, High Voltage Rectifier Assembly, High Voltage Harness;
If provided, Vent Hood, Fan assembly, Cooling Fan Motor.

All the parts marked “*” on parts list are used at voltages more than 250V.

Removal of the outer wrap gives access to voltage above 250V.

All the parts marked “ ” on parts list may cause undue microwave exposure, by themselves, or when they are damaged, loosened or removed.

PRODUCT DESCRIPTION

GENERAL INFORMATION

OPERATION

TROUBLESHOOTING GUIDE
AND TEST PROCEDURE

TOUCH CONTROL PANEL

COMPONENT REPLACEMENT AND
ADJUSTMENT PROCEDURE

WIRING DIAGRAM

PARTS LIST

ELECTROLUX HOME PRODUCTS, INC.

SPECIFICATION

ITEM	DESCRIPTION
Power Requirements Cooking)	240 Volts 7.9 Amperes (Microwave) / 14.2 Amperes (Convection)/ 12.8 Amperes (Speed 60 Hertz / Single phase, 3 wire grounded
Power Output	1000 watts (IEC Test Procedure) Operating frequency of 2450MHz
Top Heater Power Output	1500 Watts
Side Heater Power Output	1200 Watts
Case Dimensions	Width 30" Height 22-7/8" Depth 26-7/32"
Cooking Cavity Dimensions (1.1 Cubic Feet)	Width 16-1/8" Height 8-3/8" Depth 13-5/8"
Control Complement	Touch Control System Timer (0 - 99 min. 99 seconds) Microwave Power for Variable Cooking Repetition Rate; HIGH POWER Full power throughout the cooking time 90 PERCENT approx. 90% of Full Power 80 PERCENT approx. 80% of Full Power 70 PERCENT approx. 70% of Full Power 60 PERCENT approx. 60% of Full Power 50 PERCENT approx. 50% of Full Power 40 PERCENT approx. 40% of Full Power 30 PERCENT approx. 30% of Full Power 20 PERCENT approx. 20% of Full Power 10 PERCENT approx. 10% of Full Power 0 PERCENT No power throughout the cooking time Convection Temperature for Variable Cooking CONVECTION 100 - 450°F Temp. control HELP pad, Add a Minute pad, SPEED GRILL pad, SPEED ROAST pad SPEED BAKE pad, PREHEAT pad, CONVECTION pad, REHEAT pad, POPCORN pad COOK pad, DEFROST pad, BASIC COOK pad, RECIPES pad UP / DOWN pads, ENTER pad, Number and temperature selection pads, TIMER / CLOCK pad, STOP/CLEAR pad, POWER LEVEL pad, START pad
Oven Cavity Light	Yes
Safety Standard	UL Listed FCC Authorized DHHS Rules, CFR, Title 21, Chapter 1, Subchapter J Canadian Standards Association.

GENERAL INFORMATION

GROUNDING INSTRUCTIONS

This appliance must be grounded. This oven is equipped with a cord having a grounding wire with a grounding plug. It must be plugged into a wall receptacle that is properly installed and grounded in accordance with the National Electrical Code and local codes and ordinances. In the event of an electrical short circuit, grounding reduces risk of electric shock by providing an escape wire for the electric current.

WARNING – Improper use of the grounding plug can result in a risk of electric shock.

Electrical Requirements

The electrical requirements are a 240 volt 60 Hz, AC only, 15 amp. protected electrical supply. It is recommended that a separate circuit serving only this appliance be provided. The 240 volt circuit is absolutely necessary for optimum cooking performance. The oven is equipped with a 3-prong grounding plug. It must be plugged into a wall receptacle that is properly installed and grounded.

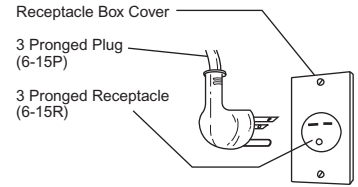

Extension Cord

If it is necessary to use an extension cord, use only a 3-wire extension cord that has a 3-blade grounding plug and a 3-slot receptacle that will accept the plug on the high speed oven. The marked rating of the extension cord should be AC 240 volt, 15 amp. or more. Be careful not to drape the cord over the countertop or table where it can be pulled on by children or tripped over accidentally.

OVEN DIAGRAM

CAUTION: DO NOT UNDER ANY CIRCUMSTANCES CUT OR REMOVE THE ROUND GROUNDING PRONG FROM THIS PLUG.

- 1 Door handle
To open the door, pull the handle down and forward. Never hold the door handle when moving the oven.
- 2 Oven door with see-through window
- 3 Safety door latches
The oven will not operate unless the door is securely closed.
- 4 Door hinges
- 5 Door seals and sealing surfaces
- 6 Turntable motor shaft
- 7 Removable turntable support
Carefully place the turntable support in the center of the oven floor. After cooking, always clean the turntable support, especially around the rollers. These must be free from food splashes and grease. Built-up splashes or grease may overheat and cause arcing, begin to smoke or catch fire.
- 8 Removable turntable
Place the turntable on the turntable support securely. The turntable will rotate clockwise or counterclockwise. Only remove for cleaning.
- 9 Ventilation openings
- 10 Oven light
It will light when oven is operating or door is open.
- 11 Waveguide cover: DO NOT REMOVE.
- 12 Auto-Touch control panel
- 13 Time display: 99 minutes, 99 seconds
- 14 Convection air openings
- 15 Removable low rack
- 16 Removable high rack
- 17 Splash guard
- 18 Ventilation cover: DO NOT

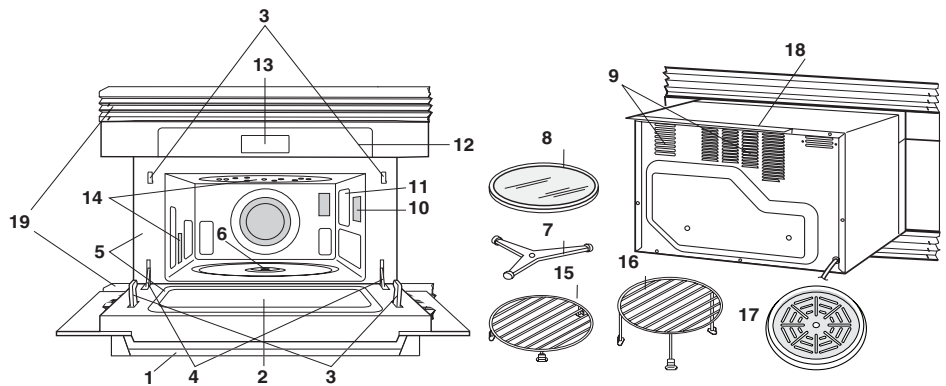

TOUCH CONTROL PANEL

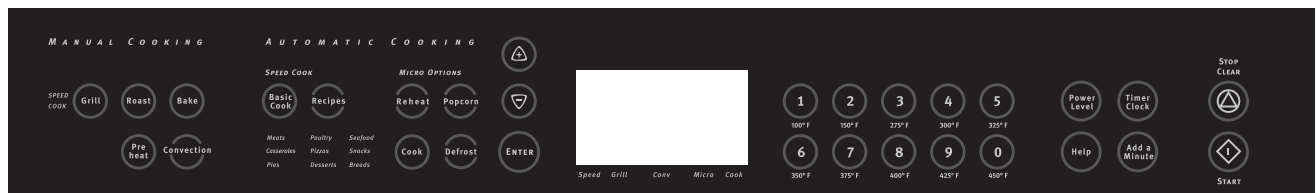

OPERATION

DESCRIPTION OF OPERATING SEQUENCE

The following is a description of component functions during oven operation.

OFF CONDITION

Closing the door activates the door sensing switch and secondary interlock switch. (In this condition, the monitor switch contacts are opened.)

When oven is plugged in, 240 volts A.C. is supplied to the control unit. **(Figure O-1)**.

1. The display will show "WELCOME TOUCH CLEAR AND TOUCH CLOCK".

To set any program or set the clock, you must first touch the STOP/CLEAR pad. The display will clear, and " : " will appear.

NOTE: When the door is opened, the oven lamp comes on.

2. A signal is input to the control unit, energizing the coil of shut-off relay (RY-4). RY4 contacts close, completing a circuit to the damper motor. The damper motor now operates moving the damper to the open position, thereby closing the contacts of the damper switch inputs a signal to the control unit. The coil of relay RY-4 is de-energized, opening its contacts, thereby turning off the damper motor.

MICROWAVE COOKING CONDITION

Program desired cooking time Variable Cooking Control by touching the NUMBER pads and the power level pad. When the START pad is touched, the following operations occur:

1. The contacts of relays are closed and components connected to the relays are turned on as follows.

(For details, refer to Figure O-2)

RELAY	CONNECTED COMPONENTS
RY-1	Oven lamp/Turntable motor
RY-2	Power transformer
RY-3	Convection motor
RY-4	Damper motor
RY-5	Fan motor
RY-6	Convection motor

2. 240 volts A.C. is supplied to the primary winding of the power transformer and is converted to about 3.3 volts A.C. output on the filament winding, and approximately 2300 volts A.C. on the high voltage winding.
3. The filament winding voltage heats the magnetron filament and the H.V. winding voltage is sent to a voltage doubler circuit.
4. The microwave energy produced by the magnetron is channelled through the waveguide into the cavity feed-box, and then into the cavity where the food is placed to be cooked.
5. Upon completion of the cooking time, the power transformer, oven lamp, etc. are turned off, and the generation of microwave energy is stopped. The oven will revert to the OFF condition.
6. When the door is opened during a cook cycle, monitor

switch, door sensing switch, relay (RY1), the primary interlock relay (RY2) and the secondary interlock switch are activated with the following results. The circuits to the turntable motor, the cooling fan motor, and the high voltage components are de-energized, the oven lamp remains on, and the digital read-out displays the time still remaining in the cook cycle when the door was opened.

7. The monitor switch is electrically monitoring the operation of the primary interlock relay (RY2) and the secondary interlock switch and is mechanically associated with the door so that it will function in the following sequence.

(1) When the door opens from a closed position, the primary interlock relay (RY2) and the secondary interlock switch open their contacts. And contacts of the relay (RY1) remain closed. Then the monitor switch contacts close.

(2) When the door is closed from the open position, the monitor switch contacts first open, and then the contacts of the secondary interlock switch close. And contacts of the relay (RY1) open.

If the primary interlock relay (RY2) and the secondary interlock switch fail with their contacts closed when the door is opened, the closing of the monitor switch contacts will form a short circuit through the monitor fuse, relay (RY1), primary interlock relay (RY2) and the secondary interlock switch, causing the monitor fuse to blow.

POWER LEVEL P-0 TO P-90 COOKING

When Variable Cooking Power is programmed, the 240 volts A.C. is supplied to the power transformer intermittently through the contacts of relay (RY-2). RY-2 is operated by the control unit within an varying time base. Microwave power operation is as follows:

VARI-MODE	ON TIME	OFF TIME
HIGH POWER (100% power)	32 sec.	0 sec.
90 PERCENT (approx. 90% power)	30 sec.	2 sec.
80 PERCENT (approx. 80% power)	26 sec.	6 sec.
70 PERCENT (approx. 70% power)	24 sec.	8 sec.
60 PERCENT (approx. 60% power)	22 sec.	10 sec.
50 PERCENT (approx. 50% power)	18 sec.	14 sec.
40 PERCENT (approx. 40% power)	16 sec.	16 sec.
30 PERCENT (approx. 30% power)	12 sec.	20 sec.
20 PERCENT (approx. 20% power)	8 sec.	24 sec.
10 PERCENT (approx. 10% power)	6 sec.	26 sec.
0 PERCENT (0% power)	0 sec.	32 sec.

Note: The ON/OFF time ratio does not correspond with the percentage of microwave power, because approx. 3 seconds are needed for heating of the magnetron filament.

CONVECTION COOKING CONDITION

PREHEATING CONDITION

Program desired convection temperature by touching the PREHEAT pad and the Temperature pad. When the START pad is touched, the following operations occur: **(Figure O-3)**

1. The coil of shut-off relays (RY1, RY3 and RY5) are energized, the oven lamp, cooling fan motor, turntable motor and convection motor are turned on.
2. The coil of relay (RY4) is energized by the control unit. The damper is moved to the closed position, closing the damper switch contacts. The closing of the damper switch contacts sends a signal to the LSI on the control unit de-energizing the relay (RY4) and opening the circuit to the damper motor.
3. The solid-state relays are energized by the control unit and the main supply voltage is applied to the top and side heating elements.
4. When the oven temperature reaches the selected preheat temperature, the following operations occur:
 - 4-1 The solid-state relays are de-energized by the control unit temperature circuit and thermistor, opening the circuit to the heating elements.
 - 4-2. The oven will continue to function for 30 minutes, turning the heating elements on and off, as needed to maintain the selected preheat temperature. The oven will shutdown completely after 30 minutes

CONVECTION COOKING CONDITION

Touch the CONVECTION pad first and then touch the Temperature pad. And program desired cooking time by touching the Number pads. When the START pad is touched, the following operations occur: **(Figure O-3)**

1. The numbers on the digital read-out start to count down to zero.
2. The oven lamp, turntable motor, cooling fan motor and convection motor are energized.
3. The damper is moved to the closed position.
4. The solid-state relays are energized (if the cavity temperature is lower than the selected temperature) and the main supply voltage is applied to the heating elements to return to the selected cooking temperature.
5. Upon completion of the cooking time, the audible signal will sound, and oven lamp, turntable motor, cooling fan motor and convection motor are de-energized. At the end of the convection cycle, if the cavity air temperature is above 230°F, the circuit to RY5 will be maintained (by the thermistor circuit) to continue operation of the cooling fan motor until the temperature drops below 195°F, at which time the relay will be de-energized, turning off the fan motor. Relay RY3 will however, open as soon as the convection cycle has ended, turning off the convection fan motor.
6. At the end of the convection cook cycle, if the cavity air temperature is below 250°F, shut-off relay (RY4) is energized turning on the damper motor. The damper is returned to the open position, closing the damper switch contacts which send a signal to the control unit, de-energizing shut-off relay (RY4).

NOTE: When "Preheat" and "Convection" is programmed continuously, after preheat, the heating elements operate as follows.

When one of 100°F to 375°F is selected, for the first 1 minute, the top and side heating elements are not energized. When one of 400°F to 450°F is selected, for the first 2 minutes, the top and side heating elements are not energized.

SPEED BAKE COOKING

Touch the BAKE pad and then enter cooking time. When the start pad is touched, following operations occur;

(Figure O-3)

1. The contacts of the relays RY1, RY3 and RY5 are closed, and the oven lamp, turntable motor, convection motor and fan motors are energized.

NOTE :The rotate direction of the convection motor is the same as one of the convection cooking.

2. The damper is moved to the closed position.
3. The solid-state relays are energized and the main supply voltage is applied to the top and side heating elements.

NOTE :After cooking, the operation of the fan motors, damper motor is the same as one of the convection cooking.

SPEED GRILL COOKING

Touch the GRILL pad and then enter cooking time. When the start pad is touched, following operations occur;

(Figure O-4)

1. The contacts of the relays RY1, RY3, RY5 and RY6 are closed, and the oven lamp, turntable motor, convection motor and fan motors are energized.

NOTE :The rotate direction of the convection motor is reverse to one of the convection cooking by the relay RY6.

2. The damper is moved to the closed position.
3. The solid-state relays are energized and the main supply voltage is applied to the top and side heating elements.

NOTE :After cooking, the operation of the fan motors, damper motor is the same as one of the convection cooking.

SPEED ROAST COOKING

Touch the ROAST pad and then enter cooking time. When the start pad is touched, following operations occur;

(Figure O-5)

1. The contacts of the relays RY1, RY3 and RY5 are closed, and the oven lamp, turntable motor, convection motor and fan motors are energized.

NOTE :The rotate direction of the convection motor is the same as one of the convection cooking for the first time. But for the last 15 minutes, the direction is reverse by the relay RY6.

2. The damper is moved to the closed position.
3. The solid-state relays and relay RY2 are energized alternately, and the main supply voltage is applied to the top and side heating elements and the power transformer alternately.

NOTE :After cooking, the operation of the fan motors, damper motor is the same as one of the convection cooking.

SPEED COOKING OF AUTOMATIC COOKING

(BASIC COOK, RECIPES)

Speed cooking of Automatic cooking will automatically compute the oven temperature, microwave power and cooking time. And the oven will cook according to the special cooking sequence.

MICROWAVE OPTIONS OF AUTOMATIC COOKING

(REHEAT, POPCORN, COOK, DEFROST)

Microwave options of Automatic cooking will automatically compute the microwave power, cooking time or defrosting time. And the oven will cook according to the special cooking sequence.

FIRE SENSING FEATURE (MICROWAVE MODE)

This model incorporates a sensing feature which will stop the oven's operation if there is a fire in the oven cavity during microwave cooking. This fire sensing feature will operate when the microwave power level is set to 80% or more. This is accomplished by the LSI repeatedly measuring the voltage across the temperature measurement circuit (thermistor) during its 32-seconds time base comparing the obtained voltage measurements. If the most recent voltage measured is 300 mV greater than the previous voltage measured, the LSI judges it as a fire in the oven cavity and switches off the relays to the power transformer, fan motor and convection motor. The LSI also stops counting down and closes the damper door so that no fresh air will enter the oven cavity.

Operation

Please refer to the timing diagrams below.

1. The fire sensing will start after 30 minutes when the oven is started.
2. The thermistor operates within a 32-seconds time

base and it is energized for three (3) seconds and off for 29 seconds. Two (2) seconds after the thermistor is energized, the voltage across the temperature measurement circuit is sampled by the LSI and twenty five (25) seconds after the thermistor is cut off the LSI turns on the convection fan for three (3) seconds.

3. The above procedure is repeated. If the difference between the first voltage measured (in step 1) and the voltage measured when the procedure is repeated (step 2) is greater than 300 mV the LSI makes the judgment that there is a fire in the oven cavity and will switch off the relays to the power transformer, fan motor and convection motor. The LSI also stops counting down and closes the damper door so that no fresh air will enter the oven cavity.

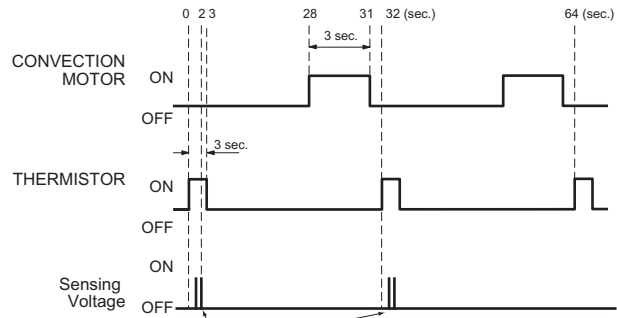

Sensing the voltage across temperature measurement circuit.

SCHEMATIC DIAGRAM

SCHEMATIC
NOTE: CONDITION OF OVEN
1. DOOR CLOSED.
2. CLOCK APPEARS ON DISPLAY.

NOTE: "★" indicates components with potential above 250V.

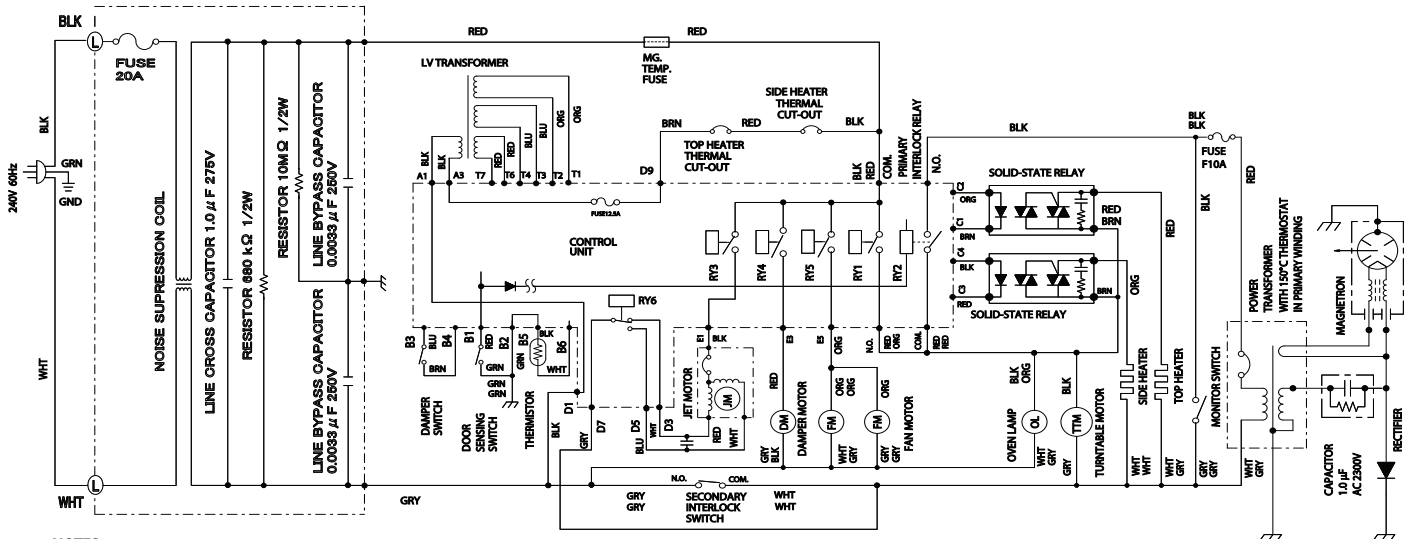

NOTES:

1. Circuits / Wire Colors subject to change without notice.

Figure O-1. Oven Schematic-OFF Condition

SCHEMATIC
 NOTE: CONDITION OF OVEN
 1. DOOR CLOSED.
 2. COOKING TIME PROGRAMMED.
 3. "START" PAD TOUCHED.

NOTE: "★" indicates components with potential above 250V.

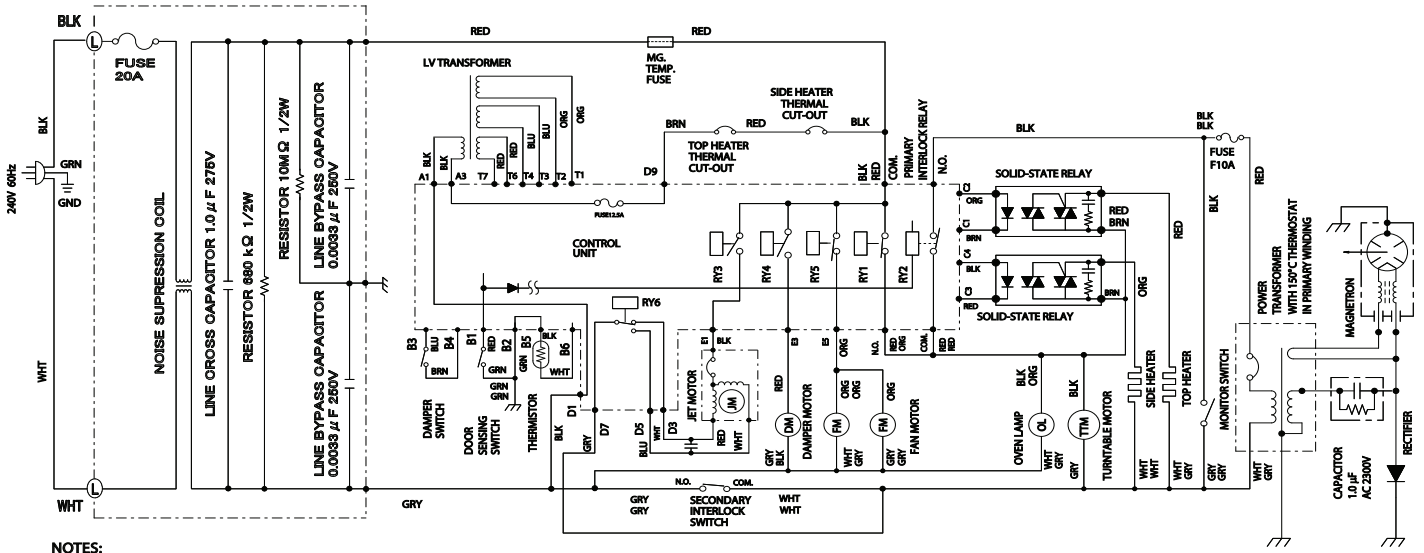

NOTES:

1. Circuits / Wire Colors subject to change without notice.

Figure O-2. Oven Schematic-Microwave Cooking Condition

SCHEMATIC (CONVECTION)
 NOTE: CONDITION OF OVEN
 1. DOOR CLOSED.
 2. CONVECTION PAD TOUCHED.
 3. DESIRED TEMPERATURE SELECTED.
 4. COOKING TIME PROGRAMMED.
 5. "START" PAD TOUCHED.

SCHEMATIC (SPEED REHEAT)
 NOTE: CONDITION OF OVEN
 1. DOOR CLOSED.
 2. REHEAT PAD TOUCHED.
 3. DESIRED TEMPERATURE SELECTED.
 4. COOKING TIME PROGRAMMED.
 5. "START" PAD TOUCHED.

SCHEMATIC (SPED BAKED)
 NOTE: CONDITION OF OVEN
 1. DOOR CLOSED.
 2. BAKED PAD TOUCHED.
 3. COOKING TIME PROGRAMMED.
 4. "START" PAD TOUCHED.

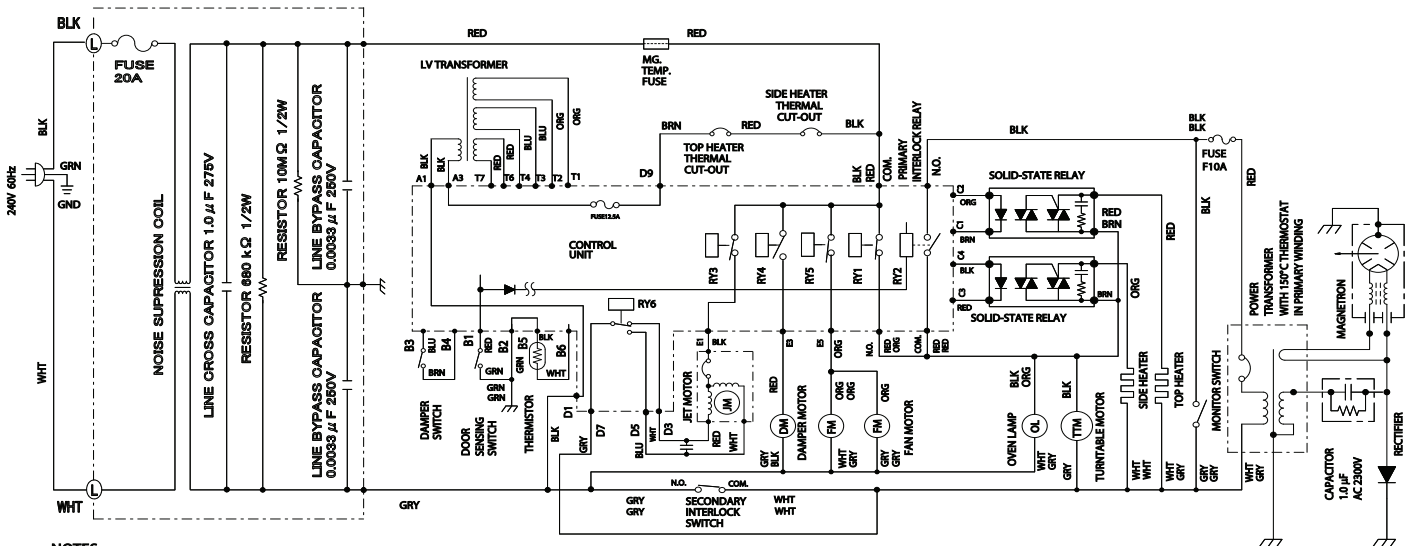

NOTES:

1. Circuits / Wire Colors subject to change without notice.

Figure O-3. Oven Schematic-Convection, Reheat, Speed Bake Cooking Condition

SCHEMATIC
 NOTE: CONDITION OF OVEN
 1. DOOR CLOSED.
 2. GRILL PAD TOUCHED.
 3. COOKING TIME PROGRAMMED.
 4. "START" PAD TOUCHED.

NOTE: "★" indicates components with potential above 250V.

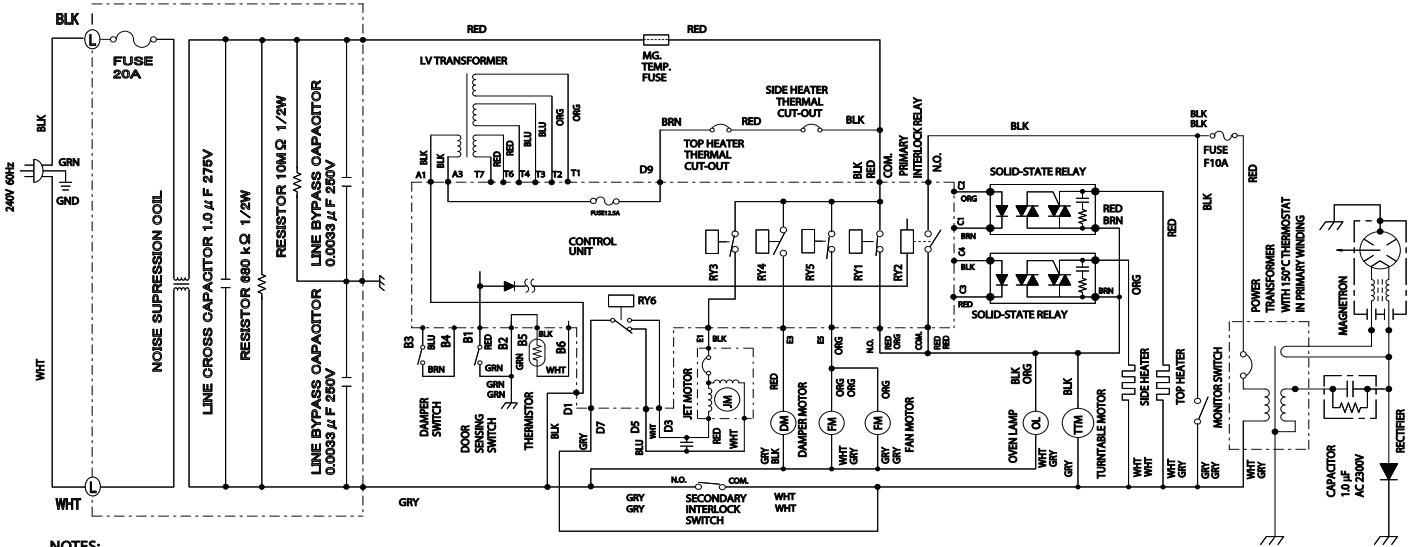

NOTES:
 1. Circuits / Wire Colors subject to change without notice.

Figure O-4. Oven Schematic-Speed Grill Cooking Condition

SCHEMATIC
 NOTE: CONDITION OF OVEN
 1. DOOR CLOSED.
 2. ROAST PAD TOUCHED.
 3. COOKING TIME PROGRAMMED.

NOTE: The solid-state relays and relay RY2 are energized alternately.
 For last 15 minutes, the contacts of relay RY6 will contact D5.

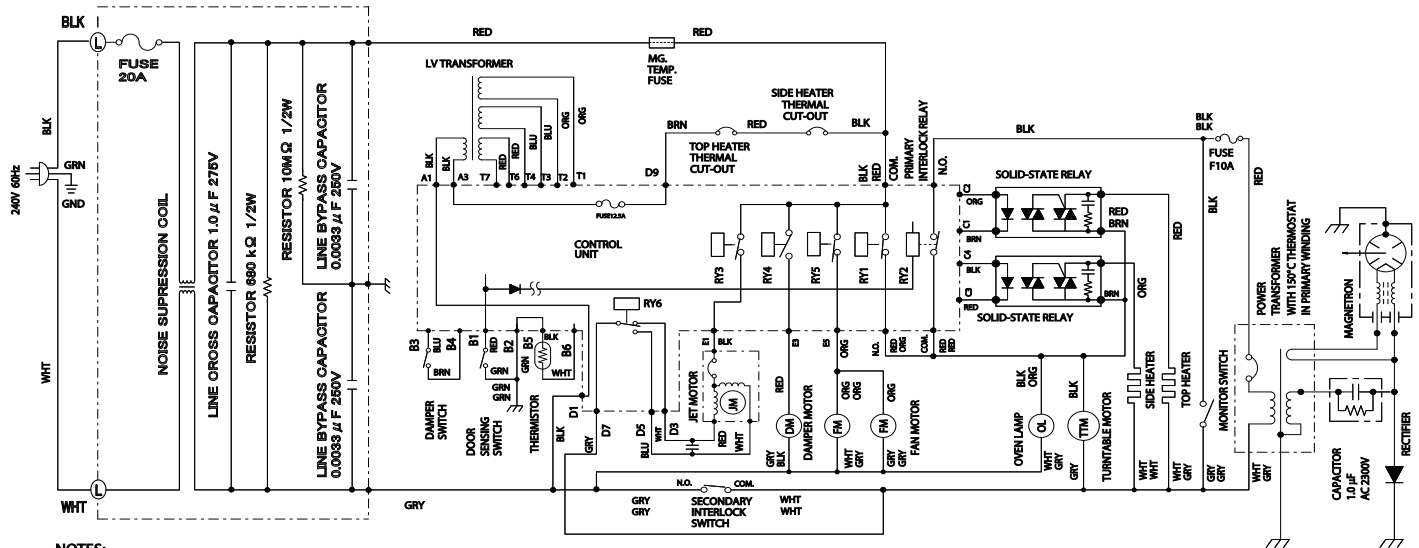

NOTES:
 1. Circuits / Wire Colors subject to change without notice.

Figure O-5. Oven Schematic-Speed Roast Cooking Condition

DESCRIPTION AND FUNCTION OF COMPONENTS

DOOR OPEN MECHANISM

The door is opened by pulling the door handle down and forward, referring to the figure D-1. When the door handle is pulled down, the latch heads are moved upward. And then when the door handle is pulled forward, the latch heads are released from the latch hooks right and left. Now, the door will open.

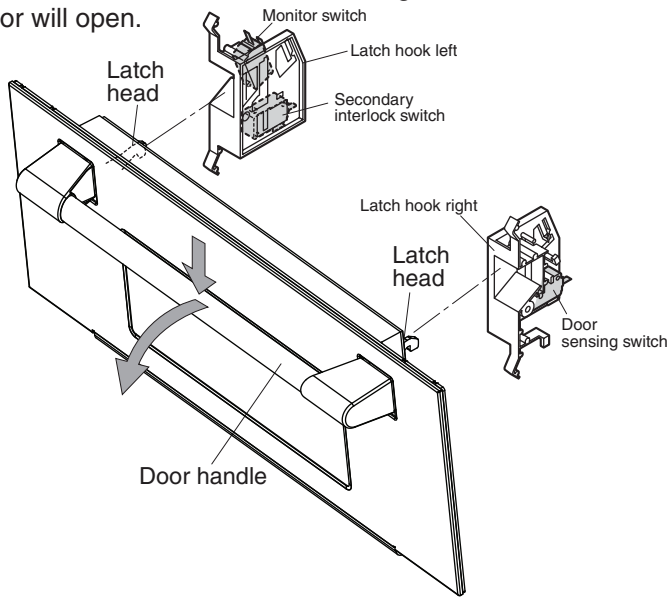

Figure D-1. Door Open Mechanism

DOOR SENSING AND SECONDARY INTERLOCK SWITCHES

The door sensing switch in the primary interlock system is mounted in the lower position on the latch hook right, the secondary interlock switch is mounted in the lower position on the latch hook left. They are activated by the latch heads on the door. When the door is opened, the switches interrupt the circuit to all components except for the oven lamp. A cook cycle cannot take place until the door is firmly closed thereby activating both interlock switches. The primary interlock system consists of the door sensing switch and primary interlock relay located on the control circuit board.

MONITOR SWITCH

The monitor switch is mounted on the upper position of latch hook left. It is activated (the contacts opened) by the left latch head while the door is closed. The switch is intended to render the oven inoperative by means of blowing the monitor fuse when the contacts of the primary interlock relay and secondary interlock switch fail to open when the door is opened.

Functions:

1. When the door is opened, the monitor switch contact close (to the ON condition) due to their being normally closed. At this time the door sensing and secondary interlock switches are in the OFF condition (contacts open) due to their being normally open contact switches.
2. As the door goes to a closed position, the monitor switch contacts are first opened and then the door sensing switch and the secondary interlock switch contacts close. (On opening the door, each of these switches operate inversely.)

3. If the door is opened, and the primary interlock relay and secondary interlock switch contacts fail to open, the monitor fuse blows simultaneously with closing of the monitor switch contacts.

CAUTION: BEFORE REPLACING A BLOWN MONITOR FUSE TEST THE DOOR SENSING SWITCH, PRIMARY INTERLOCK RELAY, SECONDARY INTERLOCK SWITCH AND MONITOR SWITCH FOR PROPER OPERATION. (REFER TO CHAPTER "TEST PROCEDURE").

NOTE: MONITOR FUSE AND MONITOR SWITCH ARE REPLACED AS AN ASSEMBLY.

THERMISTOR

The thermistor is a negative temperature coefficient type. The temperature in the oven cavity is detected through the resistance of the thermistor, and then the control unit causes the heater relay to operate, thus the current to the heating elements is turned ON/OFF. If the convection cooking or some cooking modes which use the top / side heating elements is started and the oven temperature does not rise above 100°F (37.8°C), the control unit will stop the oven after 10 minutes. In this case, the thermistor may be opened.

MAGNETRON TEMPERATURE FUSE.

The temperature fuse located on the waveguide flange is designed to prevent damage to the magnetron if an over heated condition develops in the magnetron due to cooling fan failure, obstructed air guide, dirty or blocked air intake, etc.

Under normal operation, the temperature fuse remains closed. However, when abnormally high temperatures are reached within the magnetron, the temperature fuse will remain open at 302°F (150°C) causing the oven to shut down.

TOP HEATER THERMAL CUT-OUT

The thermal cut-out located on the thermal cover upper is designed to prevent damage to the top heating element unit if an over heated condition develops in the top heating element unit due to convection fan failure, thermistor failure, obstructed air ducts, dirty or blocked air intake, etc.

Under normal operation, the thermal cut-out remains closed. However, when abnormally high temperature are reached within the top heating element unit, the thermal cut-out will open at 338°F (170°C) causing the oven to shut down. When the thermal cut-out has cooled, the thermal cut-out closes at 311°F (155°C).

SIDE HEATER THERMAL CUT-OUT

The thermal cut-out located on the thermal cover left is designed to prevent damage to the side heating element unit if an over heated condition develops in the top heating element unit due to convection fan failure, thermistor failure, obstructed air ducts, dirty or blocked air intake, etc.

Under normal operation, the thermal cut-out remains closed. However, when abnormally high temperature are reached within the side heating element unit, the thermal cut-out

will open at 302°F (150°C) causing the oven to shut down. When the thermal cut-out has cooled, the thermal cut-out closes at 266°F (130°C).

TOP HEATING ELEMENT

The top heating element is located at the top of the oven cavity. It is intended to heat air driven by the convection fan. The heated air is kept in the oven and force-circulated and reheated by the top heating element.

SIDE HEATING ELEMENT

The side heating element is located at the left side of the oven cavity. It is intended to heat air driven by the convection fan. The heated air is kept in the oven and force-circulated and reheated by the top heating element.

TURNTABLE MOTOR

The turntable motor rotates the turntable located in the bottom of the oven cavity, so that the food on the turntable is cooked evenly during cooking. The turntable may turn in either direction.

FAN MOTOR (MAGNETRON SIDE)

The fan motor drives a blade which draws external cool air. This cool air is directed through the air vents surrounding the magnetron and cools the magnetron. This air is channelled through the oven cavity to remove steam and vapors given off from the heating foods. It is then exhausted through the exhausting air vents at the oven cavity.

FAN MOTOR (POWER TRANSFORMER SIDE)

The fan motor drives a blade which draws external cool air. This cool air is directed through the air vents surrounding the power transformer and cools the power transformer. This air is channelled through the oven cavity to remove steam and vapors given off from the heating foods. It is then exhausted through the exhausting air vents at the oven cavity.

CONVECTION COOKING SYSTEM

This oven is designed with a hot air heating system where food is not directly heated by the heating element, but is heated by forced circulation of the hot air produced by the heating elements. The air heated by the heating elements is circulated through the convection passage provided on the outer casing of the oven cavity by means of the convection fan which is driven by the convection motor. It then enters the inside of the oven through the vent holes provided on the top and left sides of the oven. Next, the hot air heats the food on the turntable and leaves the oven cavity through the vent in the center of the oven cavity back side wall. Without leaving the oven, this hot air is reheated by the heating elements, passes through the convection passage and enters the inside of the oven cavity again, in a continuing cycle. In this way, the hot air circulates inside the oven cavity to raise its temperature and, at the same time, comes into contact with the food being cooked. When the temperature inside the oven cavity reaches the selected temperature, the heating elements are de-energized. When the temperature inside the oven cavity drops below the selected temperature, the heating elements are energized again. In this way, the inside of the oven cavity is maintained at approximately the

selected temperature. When the convection time reaches 0, the heating elements are de-energized and the convection fan stops operating and the oven shuts off.

Flow of hot air:

The rotation direction of the convection motor is controlled by relay RY6. When the convection fan rotates clockwise, the hot air from the oven cavity left side wall blows stronger than one from the oven cavity top wall. (This mode is called "Convection mode".) When the convection fan rotates counterclockwise, the hot air from the oven cavity top wall blows stronger than one from the oven cavity left side wall. (This mode is called "JET mode".)

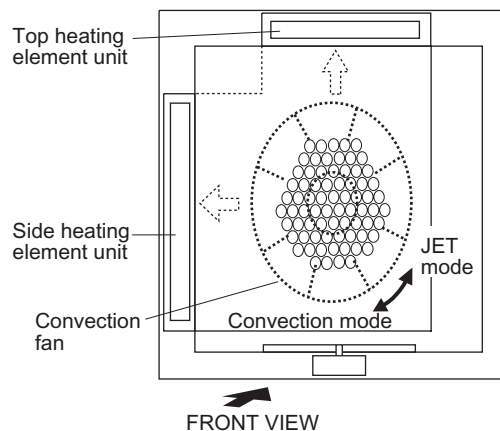

Figure D-2. Rotation direction of convection fan

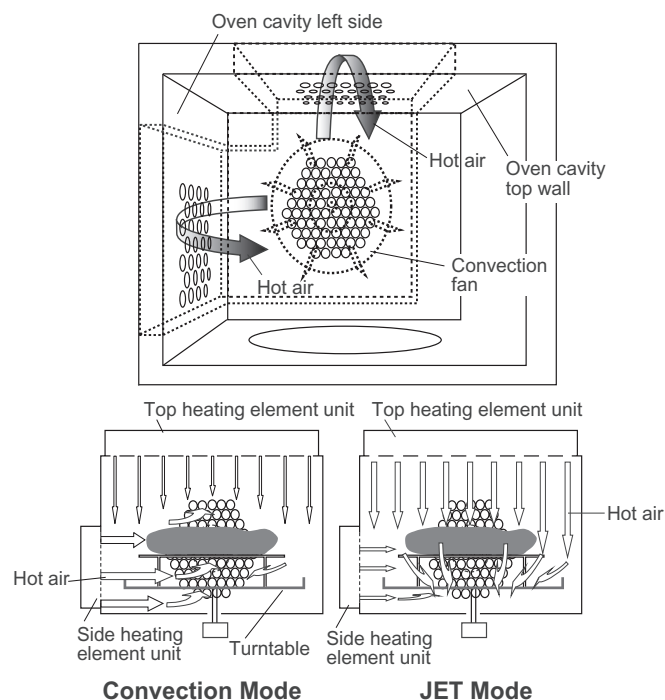

Figure D-3. Flow of hot air

DAMPER OPEN-CLOSE MECHANISM

Usually, the damper is in the open position except during convection cooking, reheat, speed grill, speed roast, speed bake, or all cooking modes which use the top / side heating elements. Damper position is set automatically by damper motor, damper switch, motor cam and damper shaft. These components are operated by a signal that judges if microwave cooking, convection cooking operation or other cooking

operation is selected by the control unit.

Microwave Cooking:

Damper is in the open position, because a portion of cooling air is channelled through the cavity to remove steam and vapors given off from the heating foods. It is then exhausted at the top of the oven cavity into a condensation compartment.

Convection, Preheat, Speed Grill, Speed Roast, Speed Bake, or all cooking modes which use the top / side heating elements:

Damper is in the closed position, so that no hot air will be allowed to leak out the oven cavity.

Damper Operation

1. When power supply cord is plugged in:
 - 1-1. When power supply cord is plugged in, a signal is sensed in the control unit, and operates shut-off relay (RY4).
 - 1-2. Contacts of shut-off relay (RY4) close, the damper motor is energized, opening the damper door.
 - 1-3. When the damper is moved to the open position by the damper cam the damper switch is opened (OFF

position).

- 1-4. The signal from damper switch is re-sensed in the control unit and shut-off relay (RY4) is turned off.
- 1-5. The 240 volts A.C. to the damper motor is removed and the motor turns off.
2. When oven is microwave cooking: Damper is in the open position.
3. When oven is convection cooking:
 - 3-1. Damper motor is energized by touching the convection, temperature and START pads.
 - 3-2. When damper is in the closed position (damper switch is ON), its signal is sensed by the control unit, and shut-off relay (RY4) is de-energized.
 - 3-3. The damper is held in the closed position during the convection cooking operation.
 - 3-4. At the end of the convection cooking, if the cavity air temperature is below 250°F, shut-off relay (RY4) is energized, and the damper is returned to the open position.

NOTE: If the damper door is not in the proper position, closed during convection or open during microwave, the control unit will stop oven

TROUBLESHOOTING GUIDE

Never touch any part in the circuit with your hand or an uninsulated tool while the power supply is connected.

When troubleshooting the microwave oven, it is helpful to follow the Sequence of Operation in performing the checks. Many of the possible causes of trouble will require that a specific test be performed. These tests are given a procedure letter which will be found in the "Test Procedure "section.

IMPORTANT: If the oven becomes inoperative because of a blown monitor fuse, check the monitor switch, relay (RY1) primary interlock relay (RY2), door sensing switch and secondary interlock switch before replacing the monitor fuse. If the monitor fuse is replaced, the monitor switch must also be replaced. Use part FFS-BA033WRKZ as an assembly.

IMPORTANT: Whenever troubleshooting is performed with the power supply cord disconnected. It may in, some cases, be necessary to connect the power supply cord after the outer case has been removed, in this event,

1. Disconnect the power supply cord
2. Remove the outer case cabinet, referring to "OUTER CASE CABINET REMOVAL".
3. Open the door and block it open.
4. Discharge high voltage capacitor.
5. Remove the back plate from the oven, referring to "BACK PLATE REMOVAL".
6. Disconnect the leads to the primary of the power transformer.
7. Ensure that the leads remain isolated from other components and oven chassis by using insulation tape.
8. After that procedure, reconnect the power supply cord.

When the testing is completed

1. Disconnect the power supply cord, and then remove outer case.
2. Open the door and block it open.
3. Discharge high voltage capacitor.
4. Reconnect all leads removed from components during testing.
5. Reinstall the outer case (cabinet) and the back plate.

TEST PROCEDURE	CONDITION	OFF CONDITION			COOKING CONDITION			(MICROWAVE)			(CONVECTION, SPEED BAKE/GRILL/ROAST)									
	PROBLEM	Home fuse blows when power cord is plugged into wall receptacle.	Monitor fuse blows when power cord is plugged into wall receptacle	88:88 does not appear in display when power cord is first plugged into wall receptacle.	Display does not operate properly when STOP/CLEAR pad is touched. (The time of day should appear on the display with beep sound.)	Oven lamp does not light with door opened.	Oven lamp does not light in cook cycle. (It light when door is opened).	Cooking cycle runs 1 minute then shuts down.	Oven lamp light, but turntable motor does not operate.	Turntable motor operates normally but cooling fan motor does not operate.	Oven does not go into a cook cycle, when START pad is touched.	Low or no power is produced during microwave cooking (The food is heated incompletely or not heated at all)	Extremely uneven heating is produced in oven load (food).	Function of variable cooking does not operate properly except HIGH power.	Function of DEFROST does not operate properly.	Oven does not go into cook cycle when START pad is touched.	Heating elements do not heat.	Temperature in the oven cavity is lower or higher than preset.	Convection cycle runs for 10 minutes then shuts down.	Convection motor does not operate of all or properly.
POSSIBLE CAUSE AND DEFECTIVE PARTS																				
A	MAGNETRON										○									
B	POWER TRANSFORMER										○									
C	H.V. RECTIFIER ASSEMBLY										○									
D	HIGH VOLTAGE CAPACITOR										○									
E	SECONDARY INTERLOCK SWITCH									○										
F	PRIMARY INTERLOCK SYSTEM				○	○				○						○	○			
G	MONITOR SWITCH	○																		
H	MONITOR FUSE			○																
J	MAGNETRON TEMPERATURE FUSE			○																
K	THERMAL CUT-OUT (TOP)			○																
M	TOP HEATING ELEMENT																○	○		
O	THERMISTOR																○	○	○	
P	DAMPER MOTOR							○										○	○	
Q	DAMPER SWITCH							○										○	○	
U	TOUCH CONTROL PANEL			○	○	○	○	○	○	○	○	○	○	○	○	○	○	○	○	○
V	TACT SWITCH				○	○	○	○	○	○	○	○	○	○	○	○	○	○	○	○
W	RELAY RY-1	○								○										
W	RELAY RY-2	○									○		○							
W	RELAY RY-3																	○		○
W	RELAY RY-4							○												
W	RELAY RY-5								○											
W	RELAY RY-6																			○
Y	DEFROST													○						
Z	FUSE1 ON PWB.			○																
X	SOLID-STATE RELAY (TOP)																○	○		
X	SOLID-STATE RELAY (SIDE)																○	○		
Replace	OVEN LAMP						○													
Replace	FAN MOTOR (MAGNETRON)								○											
Replace	TURNTABLE MOTOR							○				○								
S	CONVECTION MOTOR																	○		○
Check	LOOSE WIRING	○	○	○	○	○	○	○	○	○	○	○	○	○	○	○	○	○	○	○
Check	SHORTED IN POWER CORD	○																		
Check	NO POWER AT OUTLET			○																
Check	LOW VOLTAGE			○														○		
L	THERMAL CUT OUT (SIDE)			○																
N	SIDE HEATING ELEMENT															○	○			
Replace	FAN MOTOR (POWER TRANSFORMER)								○											
U	LV TRANSFORMER			○																
I	FUSE F10A										○									
R	CONVECTION MOTOR CAPACITOR																	○		○

TEST PROCEDURES

PROCEDURE LETTER	COMPONENT TEST
A	<p data-bbox="354 218 748 239">MAGNETRON ASSEMBLY TEST</p> <ol data-bbox="354 247 1537 653" style="list-style-type: none"> 1. Disconnect the power supply cord. 2. Remove the outer case cabinet, referring to “OUTER CASE CABINET REMOVAL”. 3. Open the oven door and block it open. 4. Discharge the high voltage capacitor. 5. Remove the back plate from the oven, referring to “BACK PLATE REMOVAL”. 6. To test for an open filament, isolate the magnetron from the high voltage circuit. A continuity check across the magnetron filament leads should indicate less than 1 ohm. 7. To test for a shorted magnetron, connect the ohmmeter leads between the magnetron filament leads and chassis ground. This test should indicate an infinite resistance. If there is little or no resistance the magnetron is grounded and must be replaced. 8. Reconnect all leads removed from components during testing. 9. Reinstall the outer case (cabinet). 10. Reconnect the power supply cord after the outer case is installed. 11. Run the oven and check all functions. <p data-bbox="354 674 719 695">MICROWAVE OUTPUT POWER</p> <p data-bbox="354 703 1537 758">The following test procedure should be carried out with the microwave oven in a fully assembled condition (outer case fitted).</p> <p data-bbox="354 779 1537 833">HIGH VOLTAGES ARE PRESENT DURING THE COOK CYCLE, SO EXTREME CAUTION SHOULD BE OBSERVED.</p> <p data-bbox="354 854 1537 993">Power output of the magnetron can be measured by performing a water temperature rise test. This test should only be used if above tests do not indicate a faulty magnetron and there is no defect in the following components or wiring: silicon rectifier, high voltage capacitor and power transformer. This test will require a 16 ounce (453cc) measuring cup and an accurate mercury thermometer or thermocouple type temperature tester. For accurate results, the following procedure must be followed carefully:</p> <ol data-bbox="354 1014 1537 1522" style="list-style-type: none"> 1. Fill the measuring cup with 16 oz. (453cc) of tap water and measure the temperature of the water with a thermometer or thermocouple temperature tester. Stir the thermometer or thermocouple through the water until the temperature stabilizes. Record the temperature of the water. 2. Place the cup of water in the oven. Operate oven at HIGH POWER (100%) selecting more than 60 seconds cook time. Allow the water to heat for 60 seconds, measuring with a stop watch, second hand of a watch or the digital read-out countdown. 3. Remove the cup from the oven and again measure the temperature, making sure to stir the thermometer or thermocouple through the water until the maximum temperature is recorded. 4. Subtract the cold water temperature from the hot water temperature. The normal result should be 29.5 to 54.9°F(16.4 to 30.5°C) rise in temperature. If the water temperatures are accurately measured and tested for the required time period the test results will indicate if the magnetron tube has low power output (low rise in water temperature) which would extend cooking time or high power output (high rise in water temperature) which would reduce cooking time. Because cooking time can be adjusted to compensate for power output, the magnetron tube assembly should be replaced only if the water temperature rise test indicates a power output well beyond the normal limits. The test is only accurate if the power supply line voltage is 240 volts and the oven cavity is clean.
B	<p data-bbox="354 1581 737 1602">POWER TRANSFORMER TEST</p> <ol data-bbox="354 1610 1537 2016" style="list-style-type: none"> 1. Disconnect the power supply cord. 2. Remove the outer case cabinet, referring to “OUTER CASE CABINET REMOVAL”. 3. Open the oven door and block it open. 4. Discharge the high voltage capacitor. 5. Remove the back plate from the oven, referring to “BACK PLATE REMOVAL”. 6. Disconnect the primary input terminals and measure the resistance of the transformer with an ohmmeter. Check for continuity of the coils with an ohmmeter. On the R x 1 scale, the resistance of the primary coil should be approximately 1.3 ohms and the resistance of the high voltage coil should be approximately 75 ohms; the resistance of the filament coil should be less than 1 ohm. 7. Also, the power transformer has the thermostat in the primary coil. Measure the resistance of the primary coil. The resistance of the primary coil should be above resistance unless the temperature of the thermostat in the primary coil reaches approximately 320°F (160°C). The thermostat resets automatically at 221°F(105°C). If an ohmmeter indicates an open circuit under normal condition, replace the power transformer because the primary coil (thermostat) has opened. An open primary coil (thermostat) indicates

TEST PROCEDURES

**PROCEDURE
LETTER**
COMPONENT TEST

overheating of the power transformer. Check for restricted air flow to the power transformer, especially the fan motor (power transformer side).

8. Reconnect all leads removed from components during testing.
9. Reinstall the outer case (cabinet) and the back plate.
10. Reconnect the power supply cord after the outer case and the back plate are installed.
11. Run the oven and check all functions.

(HIGH VOLTAGES ARE PRESENT AT THE HIGH VOLTAGE TERMINAL, SO DO NOT ATTEMPT TO MEASURE THE FILAMENT AND HIGH VOLTAGE.)

C
HIGH VOLTAGE RECTIFIER TEST

1. Disconnect the power supply cord.
2. Remove the outer case cabinet, referring to "OUTER CASE CABINET REMOVAL".
3. Open the oven door and block it open.
4. Discharge the high voltage capacitor.
5. Remove the back plate from the oven, referring to "BACK PLATE REMOVAL".
6. Isolate the rectifier from the circuit. Using the highest ohm scale of the meter, read the resistance across the terminals and observe, reverse the leads to the rectifier terminals and observe meter reading. If a short is indicated in both directions, or if an infinite resistance is read in both directions, the rectifier is probably defective and should be replaced.
7. Reconnect all leads removed from components during testing.
8. Reinstall the outer case (cabinet) and back plate.
9. Reconnect the power supply cord after the outer case and the back plate are installed.
10. Run the oven and check all functions.

NOTE: Be sure to use an ohmmeter that will supply a forward bias voltage of more than 6.3 volts.

D
HIGH VOLTAGE CAPACITOR TEST

1. Disconnect the power supply cord.
 2. Remove the outer case cabinet, referring to "OUTER CASE CABINET REMOVAL".
 3. Open the oven door and block it open.
 4. Discharge the high voltage capacitor.
 5. Remove the back plate from the oven, referring to "BACK PLATE REMOVAL".
 6. If the capacitor is open, no high voltage will be available to the magnetron. Disconnect input leads and check for short or open between the terminals using an ohmmeter.
Checking with a high ohm scale, if the high voltage capacitor is normal, the meter will indicate continuity for a short time and should indicate an open circuit once the capacitor is charged. If the above is not the case, check the capacitor with an ohmmeter to see if it is shorted between either of the terminals and case. If it is shorted, replace the capacitor.
 7. Reconnect all leads removed from components during testing.
 8. Reinstall the outer case (cabinet) and the back plate.
 9. Reconnect the power supply cord after the outer case and the back plate are installed.
 10. Run the oven and check all functions.
-

E
SECONDARY INTERLOCK SWITCH TEST

1. Disconnect the power supply cord.
2. Remove the outer case cabinet, referring to "OUTER CASE CABINET REMOVAL".
3. Open the oven door and block it open.
4. Discharge the high voltage capacitor.
5. Isolate the switch and connect the ohmmeter to the common (COM.) and normally open (NO) terminal of the switch. The meter should indicate an open circuit with the door open and a closed circuit with the door closed. If improper operation is indicated, replace the secondary interlock switch.
6. Reconnect all leads removed from components during testing.
7. Reinstall the outer case (cabinet).
8. Reconnect the power supply cord after the outer case is installed.
9. Run the oven and check all functions.

TEST PROCEDURES

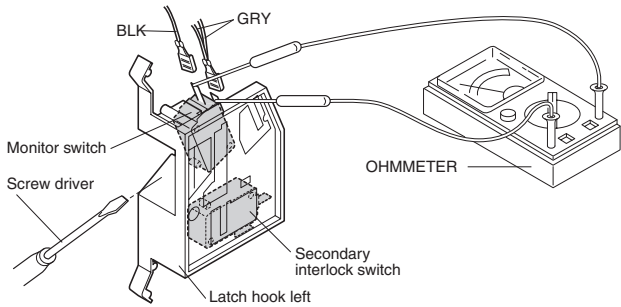
PROCEDURE LETTER	COMPONENT TEST
F	<p><u>PRIMARY INTERLOCK SYSTEM TEST</u></p> <p><u>DOOR SENSING SWITCH</u></p> <ol style="list-style-type: none"> 1. Disconnect the power supply cord, and then remove outer case. 2. Open the door and block it open. 3. Discharge high voltage capacitor. 4. Isolate the switch and connect the ohmmeter to the common (COM.) and normally open (NO) terminal of the switch. The meter should indicate an open circuit with the door open and a closed circuit with the door closed. If improper operation is indicated, replace the door sensing switch. 5. Reconnect all leads removed from components during testing. 6. Reinstall the outer case (cabinet). 7. Reconnect the power supply cord after the outer case is installed. 8. Run the oven and check all functions. <p>NOTE: If the door sensing switch contacts fail in the open position and the door is closed, the turntable motor and oven light will be activated by RY1.</p> <p><u>PRIMARY INTERLOCK RELAY (RY2)</u></p> <ol style="list-style-type: none"> 1. Disconnect the power supply cord, and then remove outer case. 2. Open the door and block it open. 3. Discharge high voltage capacitor. 4. Disconnect two (2) wire leads from the male tab terminals of the Primary Interlock Relay (RY2). Check the state of the relay contacts using an ohmmeter. The relay contacts should be open. If the relay contacts are closed, replace the circuit board entirely or the relay itself. 5. Reconnect all leads removed from components during testing. 6. Reinstall the outer case (cabinet). 7. Reconnect the power supply cord after the outer case is installed. 8. Run the oven and check all functions.
G	<p><u>MONITOR SWITCH</u></p> <ol style="list-style-type: none"> 1. Disconnect the power supply cord, and then remove outer case. 2. Open the door and block it open. 3. Discharge high voltage capacitor. 4. Before performing this test, make sure that the secondary interlock switch and the primary interlock relay are operating properly, according to the above Switch Test Procedure. Disconnect the wire lead from the monitor switch (COM) terminal. Check the monitor switch operation by using the ohmmeter as follows. When the door is open, the meter should indicate a closed circuit. When the monitor switch actuator is pushed by a screw driver through the lower latch hole on the front plate of the oven cavity with the door opened (in this condition the plunger of the monitor switch is pushed in), the meter should indicate an open circuit. If improper operation is indicated, the switch may be defective. After testing the monitor switch, reconnect the wire lead to the monitor switch (COM) terminal and check the continuity of the monitor circuit. 5. Reconnect all leads removed from components during testing. 6. Reinstall the outer case (cabinet). 7. Reconnect the power supply cord after the outer case is installed. 8. Run the oven and check all functions.
	 <p>The diagram illustrates the internal wiring and mechanical components of the oven door assembly. A screwdriver is used to actuate the monitor switch through a latch hole. The monitor switch is connected to a secondary interlock switch, and an ohmmeter is used to test the continuity of the circuit. Labels include: BLK, GRY, Monitor switch, Screw driver, Latch hook left, and OHMMETER.</p>
H	<p><u>BLOWN MONITOR FUSE</u></p> <ol style="list-style-type: none"> 1. Disconnect the power supply cord, and then remove outer case. 2. Open the door and block it open. 3. Discharge high voltage capacitor. 4. If the monitor fuse is blown when the door is opened, check the primary interlock relay, secondary interlock switch and monitor switch according to the "TEST PROCEDURE" for those switches before replacing the blown monitor fuse.

CAUTION: BEFORE REPLACING A BLOWN MONITOR FUSE, TEST THE PRIMARY INTERLOCK

TEST PROCEDURES

**PROCEDURE
LETTER**
COMPONENT TEST

RELAY, SECONDARY INTERLOCK SWITCH, DOOR SENSING SWITCH AND MONITOR SWITCH FOR PROPER OPERATION.

If the monitor fuse is blown by improper switch operation, the monitor fuse and monitor switch must be replaced with "monitor fuse and monitor switch assembly", even if the monitor switch operates normally. The monitor fuse and monitor switch assembly is comprised of a 20 ampere fuse and switch.

5. Reconnect all leads removed from components during testing.
 6. Reinstall the outer case (cabinet).
 7. Reconnect the power supply cord after the outer case is installed.
 8. Run the oven and check all functions.
-

I BLOWN FUSE F10A

1. Disconnect the power supply cord.
2. Remove the outer case cabinet, referring to "OUTER CASE CABINET REMOVAL".
3. Open the oven door and block it open.
4. Discharge the high voltage capacitor.
5. Remove the back plate from the oven, referring to "BACK PLATE REMOVAL".
6. If the monitor fuse is blown, there could be short or ground in high voltage rectifier, magnetron, power transformer, high voltage capacitor or high voltage wire. Check them and replace the defective parts or repair the wire harness.
7. Reconnect all leads removed from components during testing.
8. Reinstall the outer case (cabinet) and the back plate.
7. Reconnect the power supply cord after the outer case and back plate are installed.
8. Run the oven and check all functions.

CAUTION: ONLY REPLACE FUSE F10A WITH CORRECT VALUE REPLACEMENT.

J MAGNETRON TEMPERATURE FUSE TEST

1. Disconnect the power supply cord, and then remove outer case.
2. Open the door and block it open.
3. Discharge high voltage capacitor.
4. A continuity check across the temperature fuse terminals should indicate a closed circuit unless the temperature of the magnetron reaches approximately 302°F(150°C). An open temperature fuse indicates overheating of the magnetron. Check for restricted air flow to the magnetron, especially the cooling duct and cooling fan.
5. Reconnect all leads removed from components during testing.
6. Reinstall the outer case (cabinet).
7. Reconnect the power supply cord after the outer case is installed.
8. Run the oven and check all functions.

CAUTION: IF THE TEMPERATURE FUSE INDICATES AN OPEN CIRCUIT AT ROOM TEMPERATURE, REPLACE TEMPERATURE FUSE.

K THERMAL CUT-OUT (TOP HEATER) TEST

1. Disconnect the power supply cord, and then remove outer case.
2. Open the door and block it open.
3. Discharge high voltage capacitor.
4. A continuity check across the thermal cut-out terminals should indicate a closed circuit unless the temperature of the thermal cut-out reaches approximately 338°F(170°C). The thermal cut-out resets automatically at approximately 311°F(155°C). If thermal cut-out has opened under normal condition, replace the same item as in the parts list.
An open thermal cut-out indicates overheating of the top heating element unit. Check for restricted air flow to the top heat element unit through the vent holes of the oven cavity, especially the heater duct upper and convection fan.
5. Reconnect all leads removed from components during testing.
6. Reinstall the outer case (cabinet).
7. Reconnect the power supply cord after the outer case is installed.
8. Run the oven and check all functions.

TEST PROCEDURES

**PROCEDURE
LETTER**
COMPONENT TEST

CAUTION: IF THE THERMAL CUT-OUT INDICATES AN OPEN CIRCUIT AT ROOM TEMPERATURE, REPLACE THERMAL CUT-OUT.

L THERMAL CUT-OUT (SIDE HEATER) TEST

1. Disconnect the power supply cord, and then remove outer case.
2. Open the door and block it open.
3. Discharge high voltage capacitor.
4. A continuity check across the thermal cut-out terminals should indicate a closed circuit unless the temperature of the thermal cut-out reaches approximately 302°F(150°C). The thermal cut-out resets automatically at approximately 266°F(130°C). If thermal cut-out has opened under normal condition, replace the same item as in the parts list.
An open thermal cut-out indicates overheating of the side heating element unit. Check for restricted air flow to the side heat element unit through the vent holes of the oven cavity, especially the heater duct left and convection fan.
5. Reconnect all leads removed from components during testing.
6. Reinstall the outer case (cabinet).
7. Reconnect the power supply cord after the outer case is installed.
8. Run the oven and check all functions.

CAUTION: IF THE THERMAL CUT-OUT INDICATES AN OPEN CIRCUIT AT ROOM TEMPERATURE, REPLACE THERMAL CUT-OUT.

M TOP HEATING ELEMENT TEST

1. Disconnect the power supply cord, and then remove outer case.
 2. Open the door and block it open.
 3. Discharge high voltage capacitor.
 4. Make sure the heating element is fully cooled and test as follows;
 - a. Disconnect wire leads from the heating element and measure the resistance with an ohmmeter. On the R x 1 scale, the resistance between the heating element terminals should be approximately 32.7Ω.
 - b. Disconnect wire leads from the heating element and measure the insulation resistance with 500V - 100MΩ insulation resistance meter. The insulation resistance between heating element terminal and cavity should be more than 0.5MΩ.
 5. If the meter does not indicate above resistance, replace the top heating element.
 6. Reconnect all leads removed from components during testing.
 7. Reinstall the outer case (cabinet).
 8. Reconnect the power supply cord after the outer case is installed.
 9. Run the oven and check all functions.
-

N SIDE HEATING ELEMENT TEST

1. Disconnect the power supply cord, and then remove outer case.
 2. Open the door and block it open.
 3. Discharge high voltage capacitor.
 4. Make sure the heating element is fully cooled and test as follows;
 - a. Disconnect wire leads from the heating element and measure the resistance with an ohmmeter. On the R x 1 scale, the resistance between the heating element terminals should be approximately 46.5 Ω.
 - b. Disconnect wire leads from the heating element and measure the insulation resistance with 500V - 100MΩ insulation resistance meter. The insulation resistance between heating element terminal and cavity should be more than 0.5MΩ.
 5. If the meter does not indicate above resistance, replace the top heating element.
 6. Reconnect all leads removed from components during testing.
 7. Reinstall the outer case (cabinet).
 8. Reconnect the power supply cord after the outer case is installed.
 9. Run the oven and check all functions.
-

O THERMISTOR TEST

1. Disconnect the power supply cord.
2. Remove the outer case cabinet, referring to "OUTER CASE CABINET REMOVAL".
3. Open the oven door and block it open.

TEST PROCEDURES

PROCEDURE LETTER

COMPONENT TEST

4. Discharge the high voltage capacitor.
5. Remove the back plate from the oven, referring to "BACK PLATE REMOVAL".
6. Disconnect connector-E from the control unit. Measure the resistance of the thermistor with an ohmmeter. Connect the ohmmeter leads to Pin No's B-5 and B-6.

Room Temperature	Resistance
68°F(20°C) - 86°F(30°C)	Approx. 360 kΩ - 152 KΩ

7. If the meter does not indicate above resistance, replace the thermistor.
8. Reconnect all leads removed from components during testing.
9. Reinstall the outer case (cabinet).
10. Reconnect the power supply cord after the outer case is installed.
11. Run the oven and check all functions.

P

DAMPER MOTOR TEST

When the power cord is plugged into the wall receptacle and 240 volts A.C. is supplied to the damper motor, the motor operates until the damper is opened and the damper switch closes. Then the damper motor stops operation.

If the damper motor does not operate, check for A.C. voltage with a voltmeter at the motor.

1. Disconnect the power supply cord.
2. Remove the outer case cabinet, referring to "OUTER CASE CABINET REMOVAL".
3. Open the oven door and block it open.
4. Discharge the high voltage capacitor.
5. Remove the back plate from the oven, referring to "BACK PLATE REMOVAL".
6. Disconnect the leads to the primary of the power transformer.
7. Ensure that the leads remain isolated from other components and oven chassis by using insulation tape.
8. Disconnect the wire leads of motor and connect the meter leads to the wire leads of main wire harness.
9. Reconnect the power cord into the wall receptacle.
10. If 240 volts A.C. is indicated at the wire leads, replace the motor and if 240 volts A.C. is not indicated, check the wire harness and control unit.
11. Disconnect the power supply cord.
12. Open the door and block it open.
13. Discharge high voltage capacitor.
14. Reconnect all leads removed from components during testing.
15. Reinstall the outer case (cabinet) and the back plate.
16. Reconnect the power supply cord after the outer case and the back plate are installed.
17. Run the oven and check all functions.

Q

DAMPER SWITCH TEST

1. Disconnect the power supply cord, and then remove outer case.
2. Open the door and block it open.
3. Discharge high voltage capacitor.
4. Disconnect the leads to the primary of the power transformer.
5. Ensure that the leads remain isolated from other components and oven chassis by using insulation tape.
6. Disconnect the wire leads from the switch terminals and connect ohmmeter leads to the common (COM.) and normally open (N.O.) terminals of the switch.
- 6-1. When switch actuator is pushed by the damper motor cam, the meter should be indicated a closed circuit.
- 6-2. When power cord is plugged into the wall receptacle, the damper motor operates and damper cam will start to rotate. When the switch actuator is released, the meter should be indicated an open circuit.
7. If improper operation is indicated, replace the damper switch.
8. Disconnect the power supply cord, and then remove outer case.
9. Open the door and block it open.
10. Discharge high voltage capacitor.
11. Reconnect all leads removed from components during testing.
12. Reinstall the outer case (cabinet).
13. Reconnect the power supply cord after the outer case is installed.
14. Run the oven and check all functions.

TEST PROCEDURES

PROCEDURE LETTER	COMPONENT TEST
R	<p><u>CONVECTION MOTOR CAPACITOR TEST</u></p> <ol style="list-style-type: none"> 1. Disconnect the power supply cord, and then remove outer case. 2. Open the door and block it open. 3. Discharge high voltage capacitor. 4. Disconnect input leads and check for short or open between the terminals using an ohmmeter. Checking with a high ohm scale, if the capacitor is normal, the meter will indicate continuity for a short time and should indicate an open circuit once the capacitor is charged. If the above is not the case, check the capacitor with an ohmmeter to see if it is shorted between the terminals. If it is shorted, replace the capacitor. 5. Reconnect all leads removed from components during testing. 6. Reinstall the outer case (cabinet) and the back plate. 7. Reconnect the power supply cord after the outer case and the back plate are installed. 8. Run the oven and check all functions.
S	<p><u>CONVECTION MOTOR TEST</u></p> <ol style="list-style-type: none"> 1. Disconnect the power supply cord. 2. Remove the outer case cabinet, referring to "OUTER CASE CABINET REMOVAL". 3. Open the oven door and block it open. 4. Remove the back plate from the oven, referring to "BACK PLATE REMOVAL". 5. Disconnect the 3-pin connector of the convection motor from the main wire harness. 6. Measure the resistance of the convection motor with an ohmmeter. The resistance of the main coil, across the black and the red wires, should be approximately 130 ohms. The resistance of the sub coil, across the black and the white wires, should be approximately 140 ohms. 7. Also, the convection motor has the thermal cut-out in it. Measure the resistance of the main coil (or the sub coil). The resistance across the black and the red wires (or across the black and the white wires) should be above resistance unless the temperature of the thermal cut-out reaches approximately 266°F (130°C). The thermal cut-out resets automatically at 212°F (100°C). If an ohmmeter indicates an open circuit under normal condition, replace the convection motor because the thermal cut-out has opened. An open thermal cut-out indicates overheating of the convection motor. Check for restricted air flow to the convection motor or a lock of the convection fan, especially the fan motor (power transformer side). 8. Reconnect all leads removed from components during testing. 9. Reinstall the outer case (cabinet) and the back plate. 10. Reconnect the power supply cord after the outer case and the back plate are installed. 11. Run the oven and check all functions.
T	<p><u>CHECKING TEMPERATURE IN THE CONVECTION MODE</u></p> <p>The following test procedure should be carried out with the microwave oven in a fully assembled condition (outer case fitted).</p> <p>It is difficult to measure the exact temperature in the convection oven. An accurate thermocouple type temperature tester must be used. A low priced bi-metal type thermometer is not reliable or accurate. The temperature should be checked with outer case cabinet installed, approx. 5 minutes after preheat temperature is reached (audible signal sounds four times). The temperature experienced may be approx. 30½F more or less than indicated on the display, however, in most cases the food cooking results will be satisfactory.</p> <p>Difference in power supply voltage will also affect the oven temperature. The Household power supply voltage may sometimes become lower than the rated voltage (240 V) and cause under-cooking. If the power supply voltage is 10% lower than the rated voltage, longer cooking time is required by 10% to 20%.</p>
U	<p><u>TOUCH CONTROL PANEL ASSEMBLY TEST</u></p> <p>The touch control panel consists of circuits including semiconductors such as LSI, ICs, etc. Therefore, unlike conventional microwave ovens, proper maintenance cannot be performed with only a voltmeter and ohmmeter.</p>

TEST PROCEDURES

PROCEDURE LETTER

COMPONENT TEST

In this service manual, troubleshooting by unit replacement is described according to the symptoms indicated.

Before testing,

- 1) Disconnect the power supply cord, and then remove outer case.
- 2) Open the door and block it open.
- 3) Discharge high voltage capacitor.
- 4) Disconnect the leads to the primary of the power transformer.
- 5) Ensure that these leads remain isolated from other components and oven chassis by using insulation tape.

1. Key Unit Panel

NOTE ;

- 1) Re-install the outer case (cabinet).
- 2) Reconnect the power supply cord after the outer case is installed.
- 3) Run the oven and check all functions.

The following symptoms indicate a defective Key Unit Panel.

- a) When touching the pads, a certain pad produces no signal at all.
- b) When touching a number pad, two figures or more are displayed.
- c) When touching the pads, sometimes a pad produces no signal.

If the Key Unit Panel is defective.

- 1) Disconnect the power supply cord, and then remove outer case.
- 2) Open the door and block it open.
- 3) Discharge high voltage capacitor.
- 4) Replace the tact switch.
- 5) Reconnect all leads removed from components during testing.
- 6) Re-install the outer case (cabinet).
- 7) Reconnect the power supply cord after the outer case is installed.
- 8) Run the oven and check all functions.

2. Control Unit

The following symptoms indicate a defective control unit.

2-1 In connection with pads.

- a) When touching the pads, a certain group of pads do not produce a signal.
- b) When touching the pads, no pads produce a signal.

2-2 In connection with indicators

- a) At a certain digit, all or some segments do not light up.
- b) At a certain digit, brightness is low.
- c) Only one indicator does not light.
- d) The corresponding segments of all digits do not light up; or they continue to light up.
- e) Wrong figure appears.
- f) A certain group of indicators do not light up.
- g) The figure of all digits flicker.

2-3 Other possible problems caused by defective control unit.

- a) Buzzer does not sound or continues to sound.
- b) Clock does not operate properly.
- c) Cooking is not possible.

When testing is completed,

- 1) Disconnect the power supply cord, and then remove outer case.
- 2) Open the door and block it open.
- 3) Discharge high voltage capacitor.
- 4) Reconnect all leads removed from components during testing.
- 5) Re-install the outer case (cabinet).
- 6) Reconnect the power supply cord after the outer case is installed.
- 7) Run the oven and check all functions.

TEST PROCEDURES

PROCEDURE LETTER	COMPONENT TEST
V	<u>RELAY TEST</u>

1. Disconnect the power supply cord, and then remove outer case.
2. Open the door and block it open.
3. Discharge high voltage capacitor.
4. Disconnect the leads to the primary of the power transformer.
5. Ensure that these leads remain isolated from other components and oven chassis by using insulation tape.
6. After that procedure, re-connect the power supply cord.
7. Remove the outer case and check voltage between Pin Nos. 1 and 9 of the 5 pin connector (CN-D) on the control unit with an A.C. voltmeter. The meter should indicate 240 volts, if not check oven circuit.

Shut-off, Cook and Heater Relays Test

These relays are operated by D.C. voltage

Check voltage at the relay coil with a D.C. voltmeter during the microwave cooking operation, speed grill, speed roast, speed bake, or convection cooking condition.

DC. voltage indicated Defective relay.

DC. voltage not indicated Check diode which is connected to the relay coil. If diode is good, control unit is defective.

RELAY SYMBOL	OPERATIONAL VOLTAGE	CONNECTED COMPONENTS
RY1	Approx. 27.0V D.C.	Oven lamp / Turntable motor
RY2 (COOK)	Approx. 25.0V D.C.	Power transformer
RY3	Approx. 25.0V D.C.	Convection motor
RY4	Approx. 25.0V D.C.	Damper motor
RY5	Approx. 25.0V D.C.	Fan motor
RY6	Approx. 25.0V D.C.	Convection motor

8. Disconnect the power supply cord, and then remove outer case.
9. Open the door and block it open.
10. Discharge high voltage capacitor.
11. Reconnect all leads removed from components during testing.
12. Re-install the outer case (cabinet).
13. Reconnect the power supply cord after the outer case is installed.
14. Run the oven and check all functions.

W **SOLID-STATE RELAY TEST**

1. Disconnect the power supply and then remove outer case.
2. Open the door and block it open.
3. Discharge high voltage capacitor.
4. Disconnect the wire leads from the solid-state relay.
5. Measure the resistance between the terminals as described in the following table, with an ohmmeter.

Terminals	Resistance
Between 1 and 2	Approx. 50M Ω
Between 3 and 4	Approx. 1.3M Ω

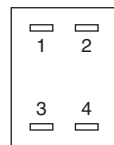

Solid-state relay

6. If the meter does not indicate above resistance, replace the solid-state relay.
7. Reconnect all leads removed from components during testing.
8. Re-install the outer case (cabinet).
9. Reconnect the power supply cord after the outer case is installed.

X **DEFROST TEST**

WARNING : The oven should be fully assembled before following procedure.

- (1) Place one cup of water in the center of the turntable tray in the oven cavity.
- (2) Close the door, touch the Compu Defrost pad and select " Steaks/Chops " by touching Up/Down

TEST PROCEDURES

PROCEDURE LETTER

COMPONENT TEST

- arrows. And touch the number pad 5. And then touch the start pad.
- (3) The oven is in Defrost cooking condition.
- (4) The oven will operate as follows.

WEIGHT	1ST STAGE		2ND STAGE		3RD STAGE	
	LEVEL	TIME	LEVEL	TIME	LEVEL	TIME
Steaks/Chops						
0.5lbs	70%	17sec.	60%	30sec.	30%	45sec.

- (5) If improper operation is indicated, the control unit is probably defective and should be checked.

Y

PROCEDURES TO BE TAKEN WHEN THE FUSE 1 ON THE PRINTED WIRING BOARD (PWB) IS OPEN.

To protect the electronic circuits, this model is provided with a fuse added to the primary on the PWB.

1. Fuse 1 check and repairs.
 - 1) Disconnect the power supply cord, and then remove outer case.
 - 2) Open the door and block it open.
 - 3) Discharge high voltage capacitor.
 - 4) If the Fuse 1 is blown, replace it.
 - 5) Make a visual inspection of the varistor. Check for burned damage and examine the transformer with a tester for the presence of layer short-circuit (check the primary coil resistance which is approximately $275\Omega \pm 10\%$). If any abnormal condition is detected, replace the defective parts.
 - 6) Reconnect all leads removed from components during testing.
 - 7) Re-install the outer case (cabinet).
 - 8) Reconnect the power supply cord after the outer case is installed.
 - 9) Run the oven and check all functions.
2. Follow the troubleshooting guide given below, if indicator does not light up after above check and repairs are finished.
 - 1) Disconnect the power supply cord, and then remove outer case.
 - 2) Open the door and block it open.
 - 3) Discharge high voltage capacitor.
 - 4) Disconnect the leads to the primary of the power transformer.
 - 5) Ensure that these leads remain isolated from other components and oven chassis by using insulation tape.
 - 6) After that procedure, re-connect the power supply cord.
 - 7) Follow the troubleshooting guide given below for repair.

STEPS	OCCURRENCE	CAUSE OR CORRECTION
1	The rated AC voltage is not present to power terminal of CPU connector (CN-D).	Check supply voltage and oven power cord.
2	The rated AC voltage is present at primary side of low voltage transformer.	Low voltage transformer or secondary circuit defective. Check and repair.

- 8) Disconnect the power supply cord, and then remove outer case.
- 9) Open the door and block it open.
- 10) Discharge high voltage capacitor.
- 11) Reconnect all leads removed from components during testing.
- 12) Re-install the outer case (cabinet).
- 13) Reconnect the power supply cord after the outer case is installed.
- 14) Run the oven and check all functions.

TEST PROCEDURES

**PROCEDURE
LETTER**

COMPONENT TEST

Z NOISE FILTER TEST

1. Disconnect the power supply cord, and then remove outer case.
2. Open the door and block it open.
3. Discharge high voltage capacitor.
4. Disconnect the leads to the primary of the power transformer.
5. Using an ohm-meter, check between the terminals as described in the following table:

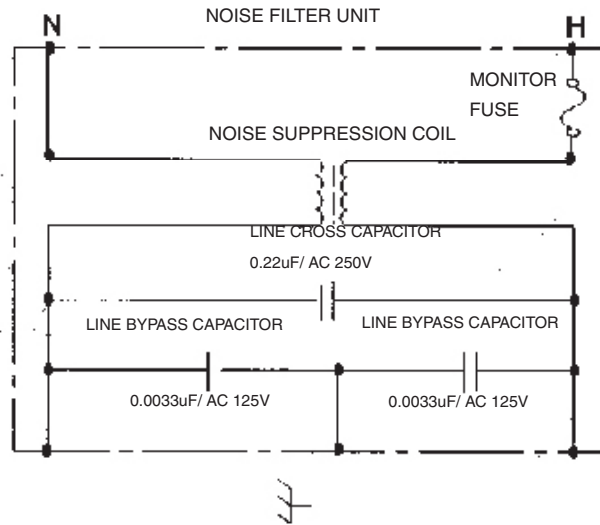

MEASURING POINT	INDICATION OF OHM-METER
Between N and H	Open Circuit
Between terminal N and GRY	Short Circuit
Between terminal H and RED	Short Circuit

If incorrect readings are obtained, replace the noise filter.

6. Reconnect all leads removed from components during testing.
7. Re-install the outer case (cabinet).
8. Reconnect the power supply cord after the outer case is installed.
9. Run the oven and check all functions.

TOUCH CONTROL PANEL DIAGRAM

The touch control section consists of the following units as shown in the touch control panel circuit.

- (1) Backlight LED function
- (2) LED function.
- (3) KEY function

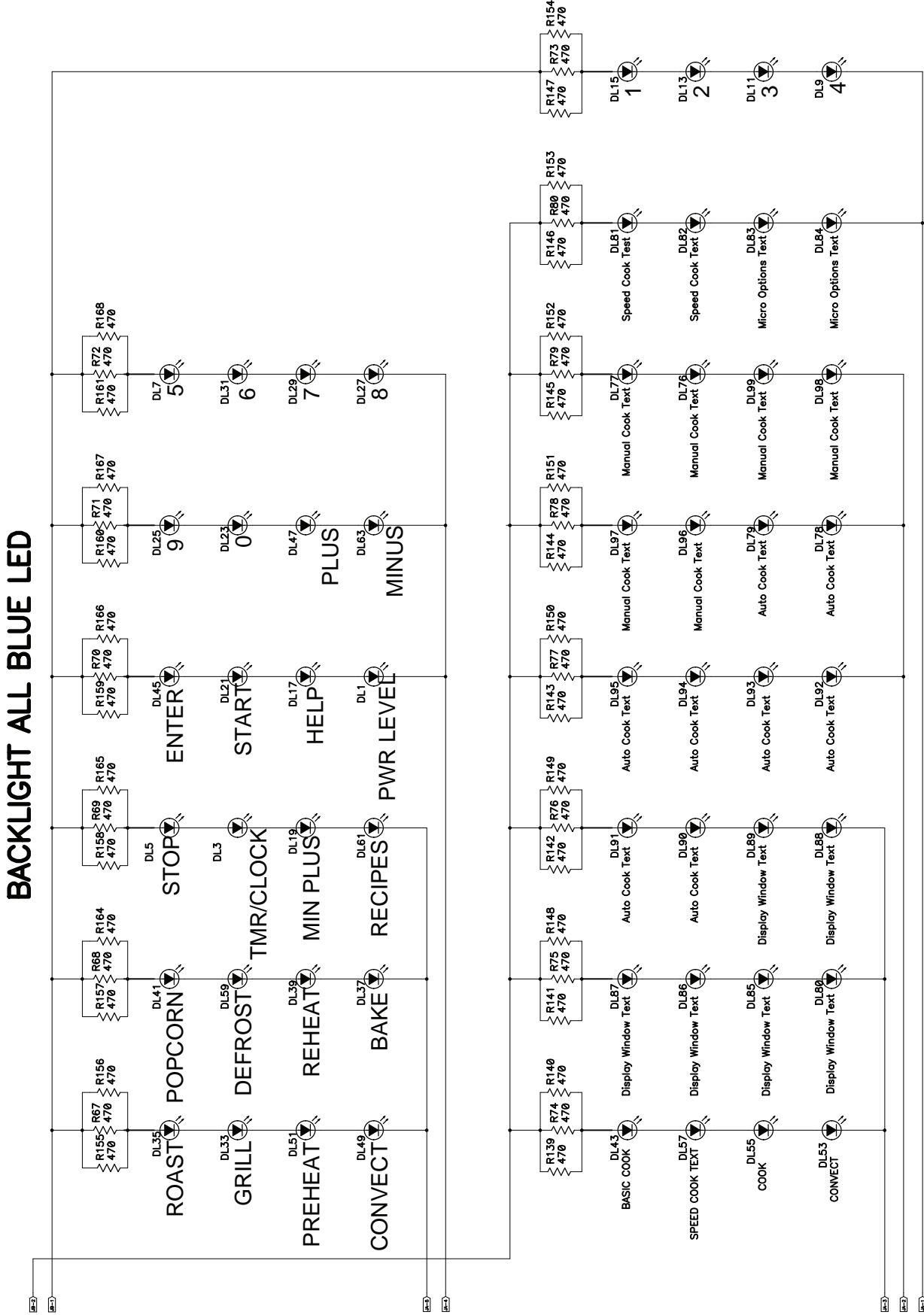

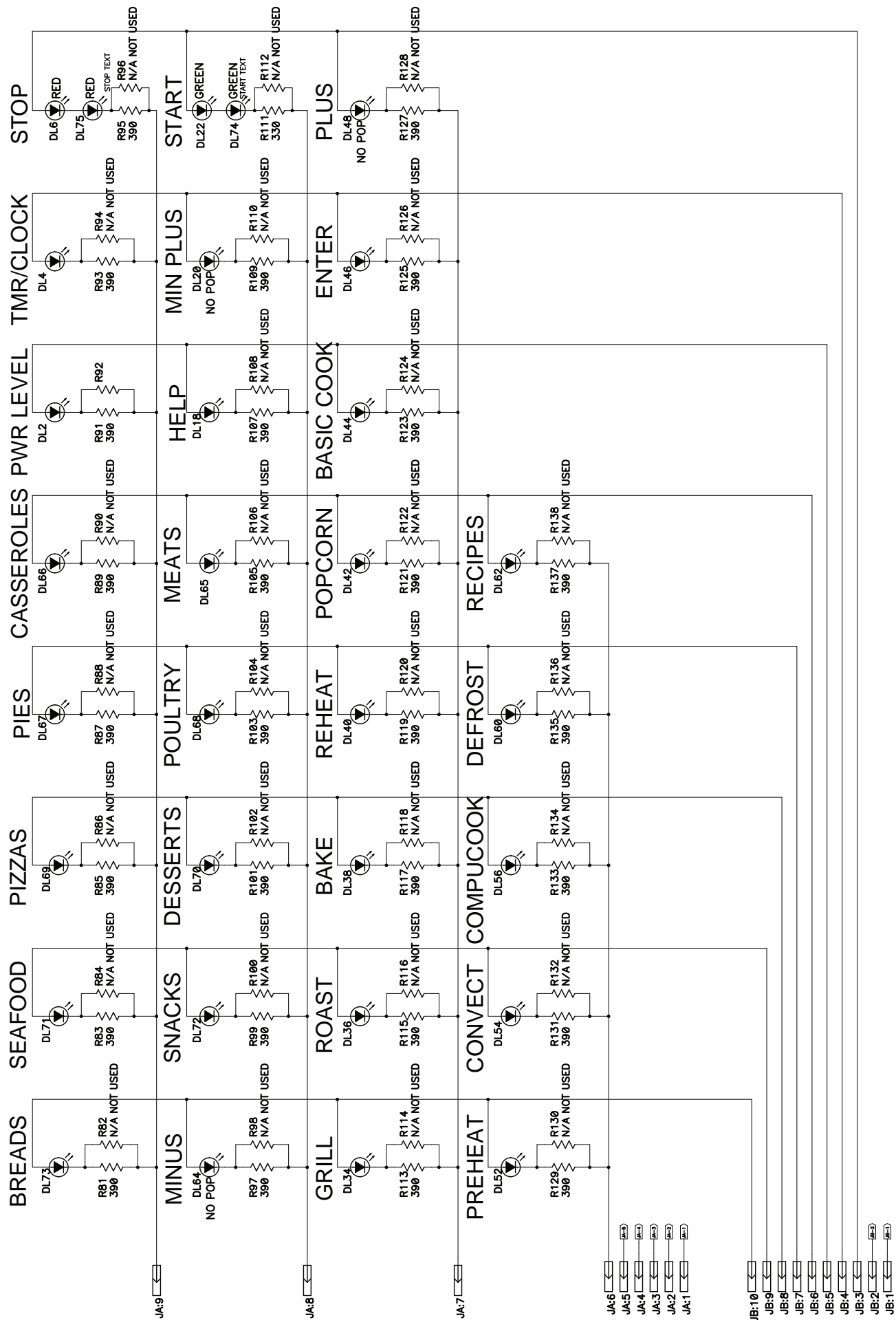

FUNCTION LED – ALL BLUE EXCEPT Start & Cancel

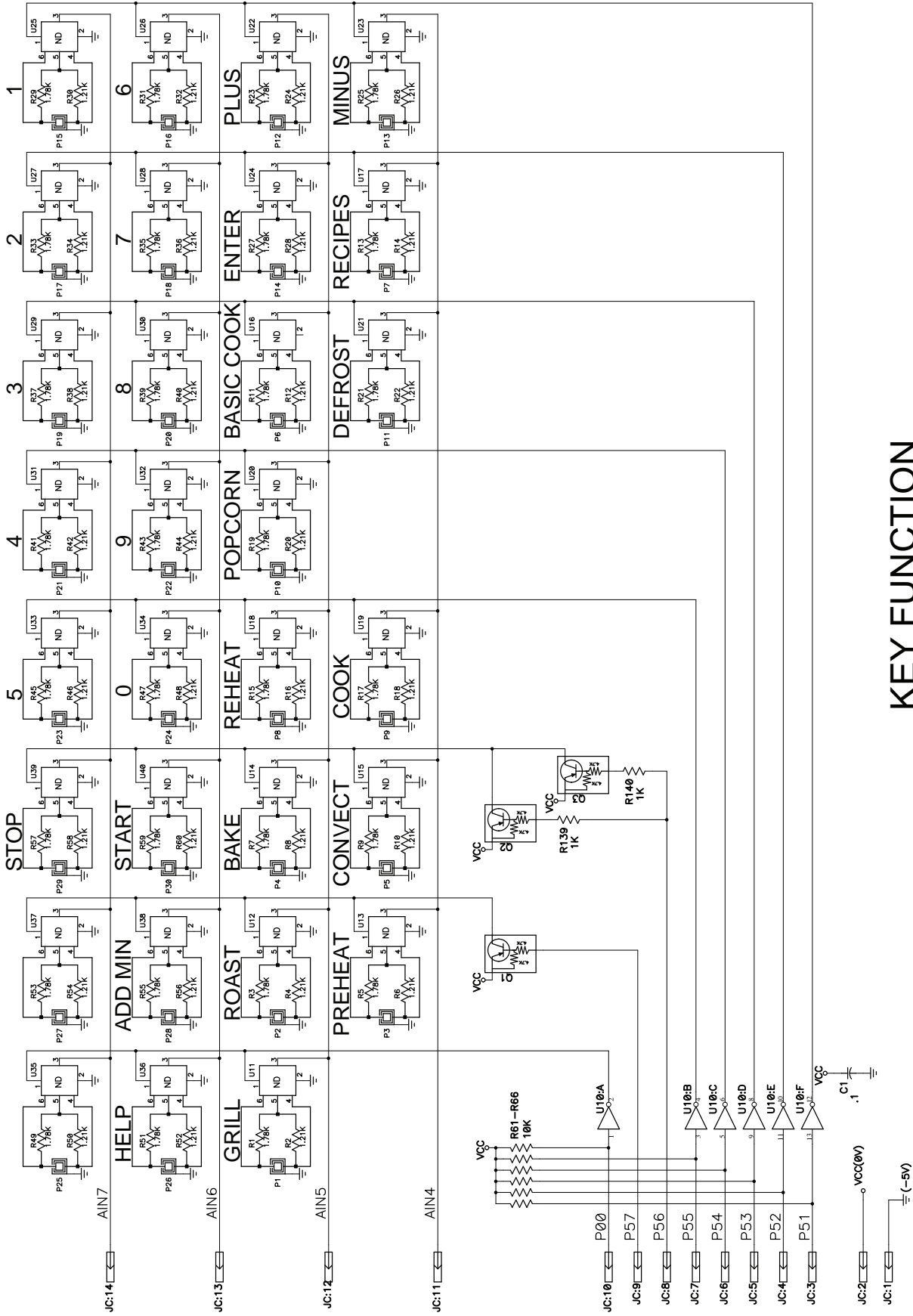

KEY FUNCTION

TOUCH CONTROL PANEL SERVICING

1. Precautions for Handling Electronic Components

This unit uses CMOS LSI in the integral part of the circuits. When handling these parts, the following precautions should be strictly followed. CMOS LSI have extremely high impedance at its input and output terminals. For this reason, it is easily influenced by the surrounding high voltage power source, static electricity charge in clothes, etc. and sometimes it is not fully protected by the built-in protection circuit. In order to protect CMOS LSI.

- 1) When storing and transporting, thoroughly wrap them in aluminium foil. Also wrap all PW boards containing them in aluminium foil.
- 2) When soldering, ground the technician as shown in the figure and use grounded soldering iron and work table.

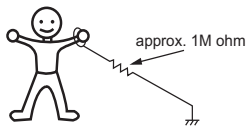

2. Shapes of Electronic Components



Regulator

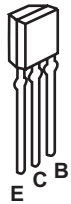

Transistor
DTA123ES
DTA143ES
DTD143ES
KRA101M
KRA117M
KRA223M
KRC101M
KRC243M

3. Servicing of Touch Control Panel

We describe the procedures to permit servicing of the touch control panel of the microwave oven and the precautions you must take when doing so. To perform the servicing, power to the touch control panel is available either from the power line of the oven itself or from an external power source.

(1) Servicing the touch control panel with power supply of the oven:

CAUTION:

THE HIGH VOLTAGE TRANSFORMER OF THE MICROWAVE OVEN IS STILL LIVE DURING SERVICING AND PRESENTS A HAZARD.

Therefore, before checking the performance of the touch control panel,

- 1) Disconnect the power supply cord, and then remove outer case.
- 2) Open the door and block it open.
- 3) Discharge high voltage capacitor.
- 4) Disconnect the leads to the primary of the power transformer.
- 5) Ensure that these leads remain isolated from other components and oven chassis by using insulation tape.
- 6) After that procedure, re-connect the power supply cord. After checking the performance of the touch control panel,
 - 1) Disconnect the power supply cord.
 - 2) Open the door and block it open.
 - 3) Re-connect the leads to the primary of the power transformer.
 - 4) Re-install the outer case (cabinet).

5) Re-connect the power supply cord after the outer case is installed.

6) Run the oven and check all functions.

- A. On some models, the power supply cord between the touch control panel and the oven itself is so short that the two can't be separated. For those models, check and repair all the controls (sensor-related ones included) of the touch control panel while keeping it connected to the oven.
- B. On some models, the power supply cord between the touch control panel and the oven proper is long enough that they may be separated from each other. For those models, it is possible to check and repair the controls of the touch control panel while keeping it apart from the oven proper; in this case you must short both ends of the door sensing switch (on PWB) of the touch control panel with a jumper, which activates an operational state that is equivalent to the oven door being closed. As for the sensor-related controls of the touch control panel, checking them is possible if dummy resistor(s) with resistance equal to that of the controls are used.

(2) Servicing the touch control panel with power supply from an external power source:

Disconnect the touch control panel completely from the oven proper, and short both ends of the door sensing switch (on PWB) of the touch control panel, which activates an operational state that is equivalent to the oven door being closed. Connect an external power source to the power input terminal of the touch control panel, then it is possible to check and repair the controls of the touch control panel it is also possible to check the sensor-related controls of the touch control panel by using the dummy resistor(s).

4. Servicing Tools

Tools required to service the touch control panel assembly.

- 1) Soldering iron: 60W
(It is recommended to use a soldering iron with a grounding terminal.)
- 2) Oscilloscope: Single beam, frequency range: DC-10MHz type or more advanced model.
- 3) Others: Hand tools

5. Other Precautions

- 1) Before turning on the power source of the control unit, remove the aluminium foil applied for preventing static electricity.
- 2) Connect the connectors of the key unit to the control unit being sure that the lead wires are not twisted.
- 3) After aluminium foil is removed, be careful that abnormal voltage due to static electricity etc. is not applied to the input or output terminals.
- 4) Attach connectors, electrolytic capacitors, etc. to PWB, making sure that all connections are tight.
- 5) Be sure to use specified components where high precision is required.

PRECAUTIONS FOR USING LEAD-FREE SOLDER

1. Employing lead-free solder

“Main PWB” of this model employs lead-free solder. The LF symbol indicates lead-free solder, and is attached on the PWBs and service manuals. The alphabetical character following LF shows the type of lead-free solder.

Example:



Indicates lead-free solder of tin, silver and copper.

2. Using lead-free wire solder

When fixing the PWB soldered with the lead-free solder, apply lead-free wire solder. Repairing with conventional lead wire solder may cause damage or accident due to cracks.

As the melting point of lead-free solder (Sn-Ag-Cu) is higher than the lead wire solder by 40°C, we recommend you to use a dedicated soldering bit.

3. Soldering

As the melting point of lead-free solder (Sn-Ag-Cu) is about 220°C which is higher than the conventional lead solder by 40°C, and as it has poor solder wettability, you may be apt to keep the soldering bit in contact with the PWB for extended period of time. However, since the land may be peeled off or the maximum heat-resistance temperature of parts may be exceeded, remove the bit from the PWB as soon as you confirm the steady soldering condition.

Lead-free solder contains more tin, and the end of the soldering bit may be easily corroded. Make sure to turn on and off the power of the bit as required.

If a different type of solder stays on the tip of the soldering bit, it is alloyed with lead-free solder. Clean the bit after every use of it.

When the tip of the soldering bit is blackened during use, file it with steel wool or fine sandpaper.

COMPONENT REPLACEMENT AND ADJUSTMENT PROCEDURE

WARNING AGAINST HIGH VOLTAGE:

Microwave ovens contain circuitry capable of producing very high voltage and current, contact with following parts may result in severe, possibly fatal, electric shock.

(Example)

High Voltage Capacitor, Power Transformer, Magnetron, High Voltage Rectifier Assembly, High Voltage Harness etc..

WARNING: Avoid possible exposure to microwave energy. Please follow the instructions below before operating the oven.

1. Disconnect the power supply cord.
2. Make sure that a definite "click" can be heard when the microwave oven door is unlatched. (Pull down the door handle in a closed position with one hand, then push the door with the other, this causes the latch leads to rise, it is then possible to hear a "click" as the door switches operate.)
3. Visually check the door and cavity face plate for damage (dents, cracks, signs of arcing etc.).
2. Door hinge, support or latch hook is damaged.
3. The door gasket or seal is damaged.
4. The door is bent or warped.
5. There are defective parts in the door interlock system.
6. There are defective parts in the microwave generating and transmission assembly.
7. There is visible damage to the oven.

Carry out any remedial work that is necessary before operating the oven.

Do not operate the oven if any of the following conditions exist;

1. Door does not close firmly.

Do not operate the oven:

1. Without the RF gasket (Magnetron).
2. If the wave guide or oven cavity are not intact.
3. If the door is not closed.
4. If the outer case (cabinet) is not fitted.

WARNING FOR WIRING

To prevent an electric shock, take the following precautions.

1. Before wiring,
 - 1) Disconnect the power supply cord.
 - 2) Open the door block it open.
 - 3) Discharge the high voltage capacitor and wait for 60 seconds.
2. Don't let the wire leads touch to the following parts;
 - 1) High voltage parts:
Magnetron, Power transformer, High voltage capacitor and High voltage rectifier assembly.
 - 2) Hot parts:
Oven lamp, Magnetron, Power transformer, Oven cavity and Heating element.
 - 3) Sharp edge:
Bottom plate, Oven cavity, Waveguide flange, Chassis support and other metallic plate.
 - 4) Moveable parts (to prevent a fault)
Fan blade, Fan motor, Switch, Door cam, Convection motor, Convection fan, Turntable motor, Damper motor, Damper door assembly.
3. Do not catch the wire leads in the outer case cabinet.
4. Insert the positive lock connector until its pin is locked and make sure that the wire leads do not come off even if the wire leads are pulled.
5. To prevent an error function, connect the wire leads correctly, referring to the Pictorial Diagram.

Please refer to 'OVEN PARTS, CABINET PARTS, CONTROL PANEL PARTS, DOOR PARTS', when carrying out any of the following removal procedures:

OUTER CASE REMOVAL

1. Disconnect the power supply cord.
2. Open the oven door and block it open.
3. Remove the two (2) special screws from the lower portion of the back plate using a T20H Torx type or GTXH20-100 screw driver.
4. Remove the four (4) screws holding the upper side of the outer case cabinet to the back plate.
5. Remove the four (4) screws holding the right and left sides of the outer case cabinet to the bottom plate.
6. Slide the entire outer case cabinet back out about 1 inch (3cm) to free it from retaining clips on the oven cavity front plate.
7. Lift entire outer case cabinet from the unit.

CAUTION

1. DISCONNECT THE OVEN FROM THE POWER SUPPLY BEFORE REMOVING THE OUTER CASE CABINET.
2. DISCHARGE THE HIGH VOLTAGE CAPACITOR BEFORE TOUCHING ANY OVEN COMPONENTS OR WIRING.

NOTE

When replacing the outer case cabinet, the two (2) special Torx screws must be reinstalled in the same locations.

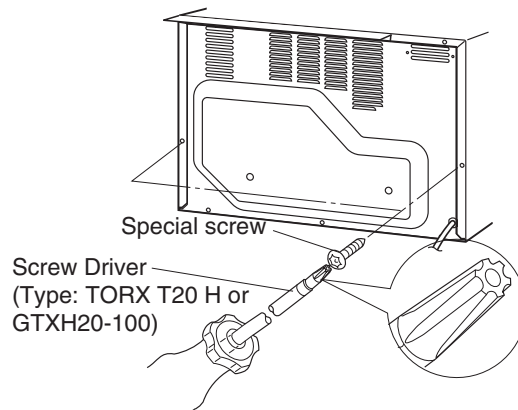
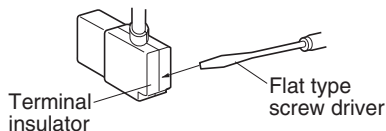

Figure C-1. Special screw position

TERMINAL INSULATOR REPLACEMENT

1. Open covers of the terminal insulator by using small flat type screw driver.
2. Remove the receptacle from the terminal insulator.
3. Now, the terminal insulator is free.

Installation

1. Insert the receptacle into terminal insulator.
2. Close covers of the terminal insulator, as shown illustrated below

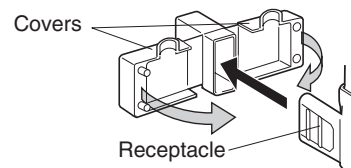

POWER SUPPLY CORD REPLACEMENT

Removal

1. Disconnect the power supply cord.
2. Remove the outer case cabinet, referring to "OUTER CASE CABINET REMOVAL".
3. Open the oven door and block it open.
4. Discharge the high voltage capacitor.
5. Remove the one (1) screw holding the green wire of the power supply cord to the bottom plate.
6. Disconnect the black wire of the power supply cord from the fuse holder, and the white wire from the main wire harness.
7. Nip the cord bushing with bushing pliers and release it from the hole of the back plate.
8. Remove the cord bushing from the power supply cord, and the power supply cord from the back plate.
9. Now, the power supply cord is free.

Reinstall

1. Reinstall the cord bushing to the power supply cord.
2. Insert the power supply cord with the cord bushing into the hole of the back plate.
3. Hold the green wire of the power supply cord to the bottom plate with the one (1) screw.
4. Reconnect the black wire of the power supply cord to the fuse holder, referring to the pictorial diagram.
5. Reconnect the white wire of the power supply cord to the main wire harness, referring to the pictorial diagram.
6. Reinstall the outer case cabinet and check that the oven is operating properly.

BACK PLATE REMOVAL

1. Disconnect the power supply cord.
2. Remove the outer case cabinet, referring to "OUTER CASE CABINET REMOVAL".
3. Open the oven door and block it open.
4. Discharge the high voltage capacitor.
5. Remove the one (1) screw holding the green wire of the power supply cord to the bottom plate.
6. Disconnect the black wire of the power supply cord from the fuse holder, and the white wire from the main wire harness.

7. Remove the three (3) screws holding the back plate to the bottom plate.
8. Remove the two (2) screws holding the right and left chassis supports to the back plate.
9. Release the tabs of the chassis supports from the back plate.
10. Now, the back plate is free.

POWER TRANSFORMER REMOVAL

1. Disconnect the power supply cord.
2. Remove the outer case cabinet, referring to "OUTER CASE CABINET REMOVAL".
3. Open the oven door and block it open.
4. Discharge the high voltage capacitor.
5. Remove the back plate from the oven, referring to "BACK PLATE REMOVAL".

6. Disconnect the main wire harness from the power transformer.
7. Disconnect the high voltage wire and filament leads of the power transformer from the high voltage capacitor and the magnetron.
8. Remove the two (2) screws holding the transformer

- mounting angle to the bottom plate from under the bottom plate.
- Remove the two (2) screws holding the transformer mounting angle to the bottom plate from the top of the bottom plate.
 - Remove the four (4) screws holding the power transformer to the transformer mounting angle.
 - Now, the power transformer is free.

MAGNETRON REMOVAL

- Disconnect the power supply cord.
- Remove the outer case cabinet, referring to "OUTER CASE CABINET REMOVAL".
- Open the oven door and block it open.
- Discharge the high voltage capacitor.
- Remove the back plate from the oven, referring to "BACK PLATE REMOVAL".
- Disconnect the high voltage wire of the high voltage rectifier assembly from the magnetron.
- Disconnect the filament wire of the power transformer from the magnetron.
- Remove the two (2) screws holding the magnetron guide to the magnetron and remove it.
- Disconnect the wire leads and the connector from the solid-state relay.
- Release the main wire harness from the hole of the magnetron separator and the hook of the fan motor.
- Remove the three (3) screws holding the magnetron separator to the bottom plate and the thermal cover back.
- Remove the magnetron separator from the oven.
- Carefully remove the four (4) screws holding the magnetron to the waveguide. When removing the screws, hold the magnetron to prevent it from falling.
- Remove the magnetron from the unit with care so the magnetron tube should not be hit by any metal object around the tube.

CAUTION: WHEN REPLACING THE MAGNETRON, BE SURE THE R.F. GASKET IS IN PLACE AND THE MAGNETRON MOUNTING SCREWS ARE TIGHTENED SECURELY.

HIGH VOLTAGE CAPACITOR AND HIGH VOLTAGE RECTIFIER ASSEMBLY REMOVAL

- Disconnect the power supply cord.
- Remove the outer case cabinet, referring to "OUTER CASE CABINET REMOVAL".
- Open the oven door and block it open.
- Discharge the high voltage capacitor.
- Remove the back plate from the oven, referring to "BACK PLATE REMOVAL".
- Disconnect the high voltage wire of the high voltage rectifier assembly from the magnetron.
- Disconnect the high voltage wire and the filament lead of the power transformer from the high voltage capacitor.
- Remove the one (1) screw holding the capacitor holder to the fan motor mounting angle.
- Remove the one (1) screw holding the high voltage rectifier assembly to the capacitor holder.
- Disconnect the high voltage rectifier assembly from the high voltage capacitor.
- Now, the high voltage rectifier assembly is free, and also the high voltage capacitor is free.

CAUTION: WHEN REPLACING THE HIGH VOLTAGE RECTIFIER ASSEMBLY, THE GROUND SIDE TERMINAL MUST BE SECURED FIRMLY WITH A GROUNDING SCREW.

FAN MOTOR REMOVAL

POWER TRANSFORMER SIDE

- Disconnect the power supply cord.
- Remove the outer case cabinet, referring to "OUTER CASE CABINET REMOVAL".
- Open the oven door and block it open.
- Discharge the high voltage capacitor.
- Remove the back plate from the oven, referring to "BACK PLATE REMOVAL".
- Remove the one (1) screw holding the capacitor holder to the fan motor mounting angle. And remove the capacitor holder from the fan motor mounting angle.
- Disconnect the wire leads from the fan motor.
- Remove the four (4) screws holding the fan motor mounting angle to the bottom plate and the thermal cover back.
- Remove the three (3) screws holding the fan motor to the fan motor mounting angle.
- Now, the fan motor is free.

MAGNETRON SIDE REMOVAL

- Disconnect the power supply cord.
- Remove the outer case cabinet, referring to "OUTER CASE CABINET REMOVAL".
- Open the oven door and block it open.
- Discharge the high voltage capacitor.
- Remove the back plate from the oven, referring to "BACK PLATE REMOVAL".
- Disconnect the wire leads from the fan motor.
- Disconnect the connector of the main wire harness from the connector of the thermistor.
- Release the main wire harness from the hole of the magnetron separator and the hook of the fan motor.
- Remove the three (3) screws holding the magnetron separator to the bottom plate and the thermal cover back.
- Remove the magnetron separator from the oven.
- Remove the one (1) screw holding the fan motor to the bottom plate.
- Now, the fan motor is free.

SOLID-STATE RELAY (MAGNETRON SIDE) REMOVAL

1. Disconnect the power supply cord.
2. Remove the outer case cabinet, referring to "OUTER CASE CABINET REMOVAL".
3. Open the oven door and block it open.
4. Discharge the high voltage capacitor.
5. Remove the back plate from the oven, referring to "BACK PLATE REMOVAL".
6. Disconnect the wire leads and the connector from the solid-state relay.
7. Release the main wire harness from the hole of the magnetron separator.
8. Remove the three (3) screws holding the magnetron separator to the bottom plate and the thermal cover back.
9. Remove the magnetron separator from the oven.
10. Remove the two (2) screws holding the solid-state relay to the magnetron separator.
11. Now, the solid-state relay is free.

DAMPER MOTOR AND DAMPER SWITCH REMOVAL

1. Disconnect the power supply cord.
2. Remove the outer case cabinet, referring to "OUTER CASE CABINET REMOVAL".
3. Open the oven door and block it open.
4. Discharge the high voltage capacitor.
5. Remove the back plate from the oven, referring to "BACK PLATE REMOVAL".
6. Remove the one (1) screw holding the right chassis support to the oven cavity front plate.
7. Disconnect the wire leads from the damper motor.
8. Remove the two (2) screws holding the damper motor to the motor mounting angle.
9. Now, the damper motor is free.
10. Disconnect the wire leads from the damper switch.
11. Remove the two (2) screws holding the motor mounting angle to the damper duct assembly.
12. Remove the one (1) screw holding the damper switch to the motor mounting angle.
13. Now, the damper switch is free.

HEATER DUCT LEFT ASSEMBLY, HEATER DUCT UPPER ASSEMBLY AND CONVECTION DUCT ASSEMBLY REMOVAL

1. Disconnect the power supply cord.
2. Remove the outer case cabinet, referring to "OUTER CASE CABINET REMOVAL".
3. Open the oven door and block it open.
4. Discharge the high voltage capacitor.
5. Remove the back plate from the oven, referring to "BACK PLATE REMOVAL".
6. Remove the door assembly from the oven, referring to "DOOR REPLACEMENT", and remove the door springs, the door cam right and the door cam left.
7. Remove the power transformer, magnetron, magnetron separator, high voltage capacitor assembly, fan motor (power transformer side) with fan mounting angle, and fan motor (magnetron side), referring to their removal procedures.
8. Disconnect the wire leads from all electrical parts except for the turntable motor, monitor switch, secondary interlock switch and door sensing switch.
9. Remove the two (2) screws holding the latch hook right and latch hook left from the oven cavity front plate.
10. Remove the two (2) screws holding the right and left chassis supports to the oven cavity front plate.
11. Remove the two (2) screws holding the exhaust duct to the oven cavity. And remove it.
12. Remove the one (1) screw holding the damper duct assembly to the oven cavity from inside of the oven cavity.
13. Remove the two (2) screws holding the damper duct assembly to the thermal cover upper and the waveguide.
14. Remove the damper duct assembly from the oven.
15. Remove the two (2) screws holding the separator left to the thermal cover upper. And remove it.
16. Disconnect the connector of the touch control transformer from the power unit.
17. Remove the one (1) screw holding the touch control transformer to the bottom plate. And remove it.
18. Remove the two (2) screws holding the PWB mounting angle to the bottom plate.
19. Remove the PWB mounting angle with the power unit from the bottom plate.
20. Remove the three (3) screws holding the thermal cover left to the heater duct left.
21. Remove the one (1) screw holding the thermal cover left to the thermal cover upper.
22. Straighten the three (3) tabs holding the thermal cover left to the oven cavity, and remove the thermal cover left and the thermal insulation left from the oven cavity.
23. Remove the two (2) screws holding the thermal cover upper to the heater duct upper.
24. Straighten the four (4) tabs holding the thermal cover upper to the oven cavity, and remove the thermal cover upper and the thermal insulation upper from the oven cavity.
25. Straighten the two (2) tabs holding the thermal insulation upper, and remove it.
26. Remove the fourteen (14) screws holding the heater duct left to the oven cavity and the convection duct.
27. Remove the heater duct left assembly from the oven cavity.
28. Now, the heater duct left assembly is free.
29. Remove the two (2) screws holding the convection motor

mounting angle to the bottom plate from under the bottom plate.

30. Remove the thirteen (13) screws holding the convection duct to the oven cavity and the heater duct upper.
31. Remove the convection duct assembly from the oven

cavity.

32. Now, the convection duct assembly is free.
33. Remove the nine (9) screws holding the heater duct upper to the oven cavity.
34. Remove the heater duct upper from the oven cavity.
35. Now, the heater duct upper assembly is free.

SIDE HEATING ELEMENT REMOVAL

1. Disconnect the power supply cord.
2. Remove the outer case cabinet, referring to "OUTER CASE CABINET REMOVAL".
3. Open the oven door and block it open.
4. Discharge the high voltage capacitor.
5. Remove the back plate from the oven, referring to "BACK PLATE REMOVAL".
6. Remove the heater duct left assembly from the oven cavity, referring to "HEATER DUCT LEFT ASSEMBLY, HEATER

DUCT UPPER ASSEMBLY AND CONVECTION DUCT ASSEMBLY REMOVAL

7. Remove the one (1) screw holding the heater mounting angle B to the heater duct left.
8. Remove the two (2) nuts holding the side heating element to the heater duct left.
9. Now, the side heating element is free.

CONVECTION MOTOR REMOVAL

1. Disconnect the power supply cord.
2. Remove the outer case cabinet, referring to "OUTER CASE CABINET REMOVAL".
3. Open the oven door and block it open.
4. Discharge the high voltage capacitor.
5. Remove the back plate from the oven, referring to "BACK PLATE REMOVAL".
6. Remove the convection duct assembly from the oven cavity, referring to "HEATER DUCT LEFT ASSEMBLY, HEATER DUCT UPPER ASSEMBLY AND CONVECTION DUCT ASSEMBLY REMOVAL

7. Loosen the one (1) screw holding the convection fan assembly to the convection fan motor shaft with a hexagon key wrench, and remove the convection fan.
8. Remove the four (4) screws holding the convection motor mounting angle to the convection duct.
9. Remove the six (6) screws holding the convection motor to the convection motor mounting angle.
10. Remove the convection motor from the convection motor mounting angle.
11. Now, the convection motor is free.

TOP HEATING ELEMENT REMOVAL

1. Disconnect the power supply cord.
2. Remove the outer case cabinet, referring to "OUTER CASE CABINET REMOVAL".
3. Open the oven door and block it open.
4. Discharge the high voltage capacitor.
5. Remove the back plate from the oven, referring to "BACK PLATE REMOVAL".
6. Remove the heater duct left assembly from the oven cavity, referring to "HEATER DUCT LEFT ASSEMBLY, HEATER

DUCT UPPER ASSEMBLY AND CONVECTION DUCT ASSEMBLY REMOVAL

7. Remove the one (1) screw holding the heater mounting angle A to the heater duct upper.
8. Remove the two (2) nuts holding the top heating element to the heater duct upper.
9. Now, the top heating element is free.

TURNTABLE MOTOR REMOVAL

1. Disconnect the power supply cord.
2. Wait for 60 seconds to discharge the high voltage capacitor.
3. Remove the turntable tray and the turntable support from the oven cavity.
4. Lay the oven on its backside.
5. Remove the turntable motor cover by snipping off the material in four corners.
6. Where the corners have been snipped off, bend corner areas flat. No sharp edges must be evident after removal of the turntable motor.

7. Disconnect the wire leads from the turntable motor.
8. Remove the one (1) screw holding the turntable motor to the oven cavity bottom plate.
9. Now, the turntable motor is free.
10. After replacement, use the one (1) screw to fit the turntable motor cover.

DOOR SENSING SWITCH, SECONDARY INTERLOCK SWITCH AND MONITOR SWITCH REPLACEMENT

Removal

1. Disconnect the power supply cord.

2. Remove the outer case cabinet, referring to "OUTER CASE CABINET REMOVAL".

3. Open the oven door and block it open.
4. Discharge the high voltage capacitor.
5. Disconnect the wire leads from the switch.
6. Remove the one (1) screw holding the latch hook (right or left) to the oven cavity front plate, and release the latch hook (right or left).
7. Keep pushing the stopper tub holding the switch to the latch hook (right or left) and revolve the switch on the pole.
8. Remove the switch from the latch hook (right or left).
9. Now, the switch is free.

Reinstallation

1. Reinstall the switch in its place. The door sensing switch is in the lower position of the latch hook right. The secondary interlock switch is in the lower position of the latch hook left. And the monitor switch is in the upper position of the latch hook left.
2. Hold the latch hook (right or left) to the oven cavity front plate with the one (1) screw.

3. Reconnect the wire leads to the switch.
4. Make sure that the monitor switch is operating properly and check continuity of the monitor circuit. Refer to chapter "Test Procedure" and "Adjustment procedure."

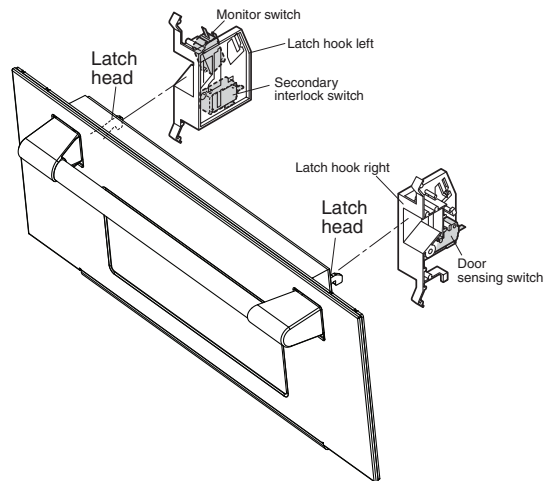

Figure C-2. Switches

DOOR SENSING SWITCH, SECONDARY INTERLOCK SWITCH AND MONITOR SWITCH ADJUSTMENT

If the door sensing switch, secondary interlock switch and monitor switch do not operate properly due to a misadjustment, the following adjustment should be made.

1. Disconnect the power supply cord.
2. Remove the outer case cabinet, referring to "OUTER CASE CABINET REMOVAL".
3. Open the oven door and block it open.
4. Discharge the high voltage capacitor.
5. Loosen each one (1) screw holding the latch hook right and the latch hook left to the oven cavity front plate.
6. With door closed, adjust the latch hook right and the latch hook left by moving them back and forth, and up and down. In and out play of the door allowed by the latch hook right and the latch hook left should be less than 0.5 mm. The vertical position of the latch hook right and the latch hook left should be adjusted so that the door sensing switch and the secondary interlock switch are activated with the door closed. The horizontal position of the latch hook right and the latch hook left should be adjusted so that the plunger of the monitor switch is pressed with the door closed.
7. Secure the screws firmly.
8. Check all of the switches operation. If any switch has not activated with the door closed, loosen the screws and adjust the position of the latch hook right and the latch hook left.

After adjustment, check the following.

1. In and out play of the door remains less than 0.5 mm when in the latched position. First check the position of the latch hook right, pushing and pulling right portion of the door toward the oven face. Then check the position

of the latch hook left, pushing and pulling left portion of the door toward the oven face. Both results (play in the door) should be less than 0.5 mm.

2. The door sensing switch and the secondary interlock switch interrupt the circuit before the door can be opened.
3. The monitor switch contacts close when the door is opened.
4. Reinstall the outer case cabinet and check for microwave leakage around the door with an approved microwave survey meter. (Refer to Microwave Measurement Procedure.)

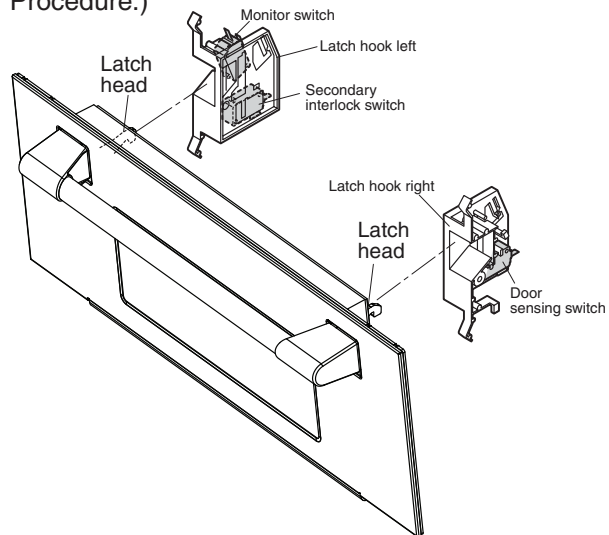

Figure C-3. Latch Switch Adjustment

DOOR REPLACEMENT AND ADJUSTMENT

Door assembly removal

1. Disconnect the power supply cord.
2. Remove the outer case cabinet, referring to "OUTER

CASE CABINET REMOVAL".

3. Open the oven door and block it open.
4. Discharge the high voltage capacitor.

5. Close the door.
6. Remove the two (2) door springs from the door cam right, oven hinge right, door cam left and oven hinge left.
7. Release the door cams right and left from the right and left door cam pins of the door.
8. Remove the door cams right and left from the oven cavity front plate.
9. Open the door assembly at an angle of more than 90½ with the oven cavity front plate.
10. To release the right and left door hinge pins of the door assembly from the oven hinges right and left, slide the door assembly leftward. When removing the door assembly, hold the door assembly to prevent it from falling.
11. Now, the door assembly is free.

NOTE: When the individual parts are replaced, refer to “Door Disassembly”

Door assembly reinstallation

1. On reinstalling the door assembly, insert the oven hinges right and left into the right and left door hinge pins.
2. Insert and hook the door cams right and left to the right and left door cam pins.
3. Reinstall the two (2) door springs between the door cams and the oven hinges right and left.

NOTE: After any service to the door;

(A) Make sure that the door sensing switch and the secondary interlock switch are operating properly. (Refer to chapter “Test Procedure”.)

(B) An approved microwave survey meter should be used to assure compliance with proper microwave radiation emission limitation standards.

Door adjustment

When removing and/or loosening the oven hinges such as in door replacement, the following adjustment criteria are taken.

Door adjustment is performed with the door properly installed and closed and while the oven hinges are loose.

1. Loosen the screws holding the oven hinge right and the oven hinge left to the bottom plate with screwdriver.
2. Adjust the door by moving it so that the door is parallel with the oven cavity front plate lines (right and left side lines) and the door latch heads pass through the latch holes correctly.
3. Tighten the screws holding the oven hinge right and the oven hinge left to the bottom plate.

After adjustment, make sure of the following:

1. The door latch heads smoothly catch the latch hooks through latch holes and the latch heads goes through center of latch holes.

2. The door is positioned with its face pressed toward oven cavity front plate.
3. Reinstall the outer case cabinet and check for microwave leakage around the door with an approved microwave survey meter. (Refer to Microwave Measurement Procedure.)

NOTE: The door on a microwave oven is designed to act as an electronic seal preventing the leakage of microwave energy from the oven cavity during cook cycle. This function does not require that the door be airtight, moisture (condensation)-tight or light-tight. Therefore, occasional appearance of moisture, light or sensing of gentle warm air movement around the oven door is not abnormal and do not of themselves indicate a leakage of microwave energy from the oven cavity. If such were the case, your oven could not be equipped with a vent, the very purpose of which is exhaust the vapor-laden air from the oven cavity.

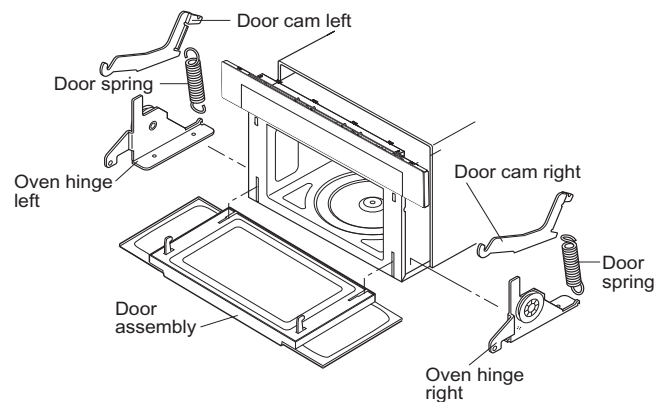

Figure C-4(a). Door Replacement

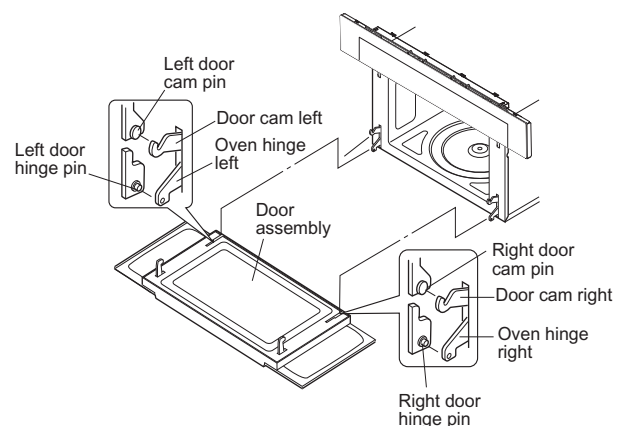

Figure C-4(b). Door Replacement

DOOR DISASSEMBLY

1. Disconnect the power supply cord.
2. Remove the outer case cabinet, referring to “OUTER CASE CABINET REMOVAL”.
3. Open the oven door and block it open.
4. Discharge the high voltage capacitor.
5. Remove the door assembly, referring to “Door Replacement”.

6. Place the door assembly on a soft cloth with latch heads facing up.

NOTE: As the engaging parts of the choke cover and the door panel assembly are provided at 16 places, do not force any particular part.

7. Replacement of the door components are as follows:

CHOKE COVER

8. Insert a putty knife (thickness of about 0.5 mm) into the gap between the choke cover and the door panel assembly as shown in Figure C-5.
9. Lift up the choke cover.
10. Now, the choke cover is free from the door panel assembly.

NOTE: When carrying out any repair to the door, do not bend or warp the slit choke (tabs on the door panel assembly) to prevent microwave leakage.

DOOR HANDLE ASSEMBLY

11. Remove the two (2) screws holding the door handle assembly to the door panel assembly through the door frame.
12. Now, the door handle is free.

DOOR PANEL ASSEMBLY, LATCH HEAD R AND LATCH HEAD L

13. Remove the fourteen (14) screws holding the door panel assembly to the door frame.
14. Remove the door panel assembly from the door frame.
15. Remove the one (1) screw holding the latch head R to the door panel assembly.
16. Remove the latch spring R from the latch head R and the handle lever.
17. Now, the latch head R is free.
18. Remove the one (1) screw holding the latch head L to the door panel assembly.
19. Remove the latch spring L from the latch head L and the handle lever.
20. Now, the latch head L is free.
21. Release the two (2) handle springs from the two (2)

handle levers.

22. Pull out the two (2) handle pins from the two (2) handle levers.
23. Remove the two (2) handle levers from the door panel.
24. Now, the door panel is free.

MIDDLE DOOR GLASS

25. Remove the two (2) screws holding the glass mounting angle B to the door frame.
26. Remove the middle door glass from the door frame.
27. Now, the middle door glass is free.

FRONT DOOR GLASS

28. Remove each two (2) screws holding the two glass mounting angles A to the door frame.
29. Remove the two (2) glass mounting angles A from the door frame.
30. To release the two (2) tabs holding the lower end of the front door glass, slide the front door glass upward.
31. Release the three (3) tabs holding the upper end of the front door glass and remove the front door glass from the door frame.
32. Now, the front door glass is free.

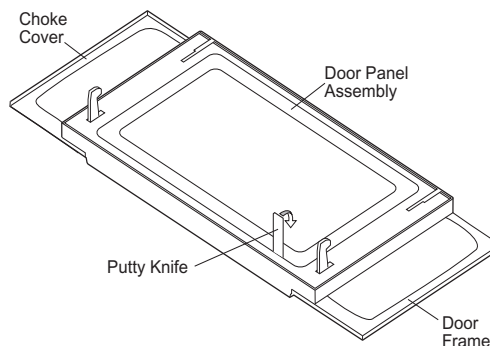

Figure C-5. Door Disassembly

CONTROL PANEL ASSEMBLY AND CPU UNIT REMOVAL

Control panel assembly

1. Disconnect the power supply cord.
2. Remove the outer case cabinet, referring to "OUTER CASE CABINET REMOVAL".
3. Open the oven door and block it open.
4. Discharge the high voltage capacitor.
5. Disconnect the 9-pin & 14-pin harness from the connectors CN-J and CN-H on the power unit.
6. Remove the four (4) screws holding the control panel assembly to the oven cavity front plate.
7. Insert a flat edge screw driver or similar object to release the Locking Tabs on bottom of Panel angle (Fig. C-6).
8. Slide the control panel assembly leftward to release the eight (6) tabs of the control panel assembly from the oven cavity front plate.
9. Now, the control panel assembly is free.

CPU unit

10. Disconnect the 14-pin (CNK), 9-pin (CNL) & 10-pin (CNM) harness from the connectors. CN-J and CN-H on the power unit.
11. Remove the eight (8) screws holding the CPU unit to the panel sub assembly.
12. Now, the CPU unit is free.

NOTE: After the panel angle is removed from the panel sub assembly, it can be found that the bottom side of the panel sub assembly is melted and transformed by heat. But it is not abnormal and no problem to use the oven.

Reassembling note: When reassembling the Control Panel assembly, be sure and lock the (Locking Tabs) back into place to prevent any gaps.

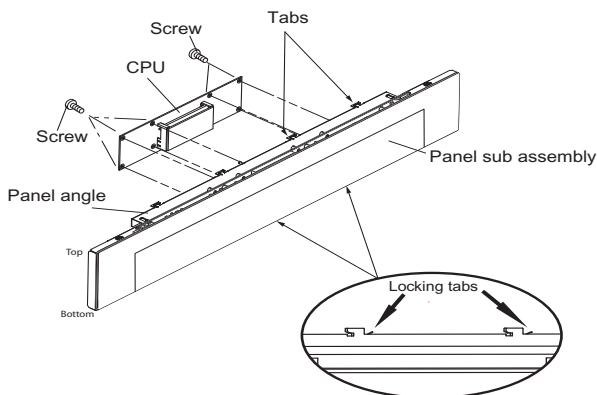

Figure C-6. Panel Angle Removal

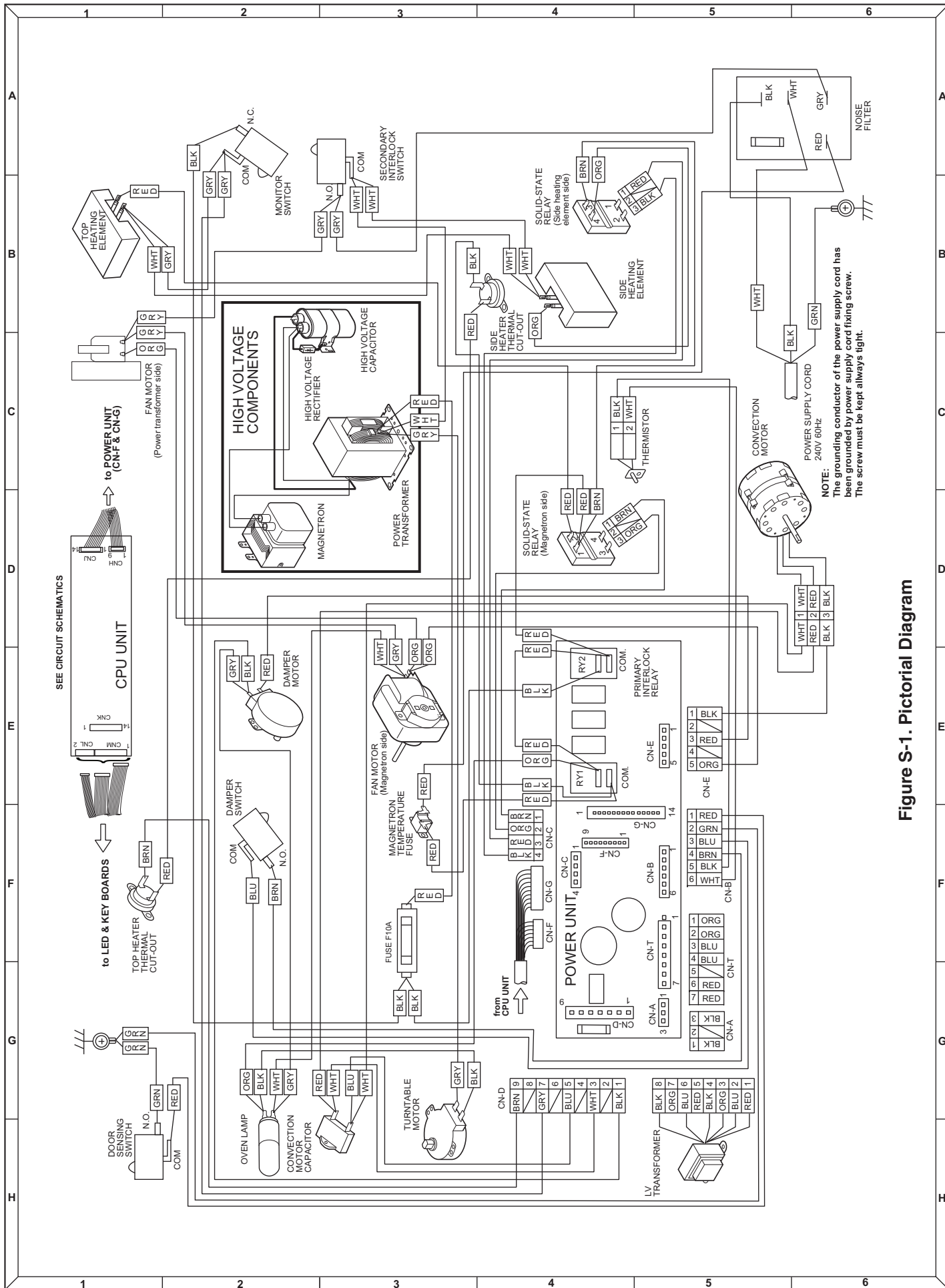

Figure S-1. Pictorial Diagram

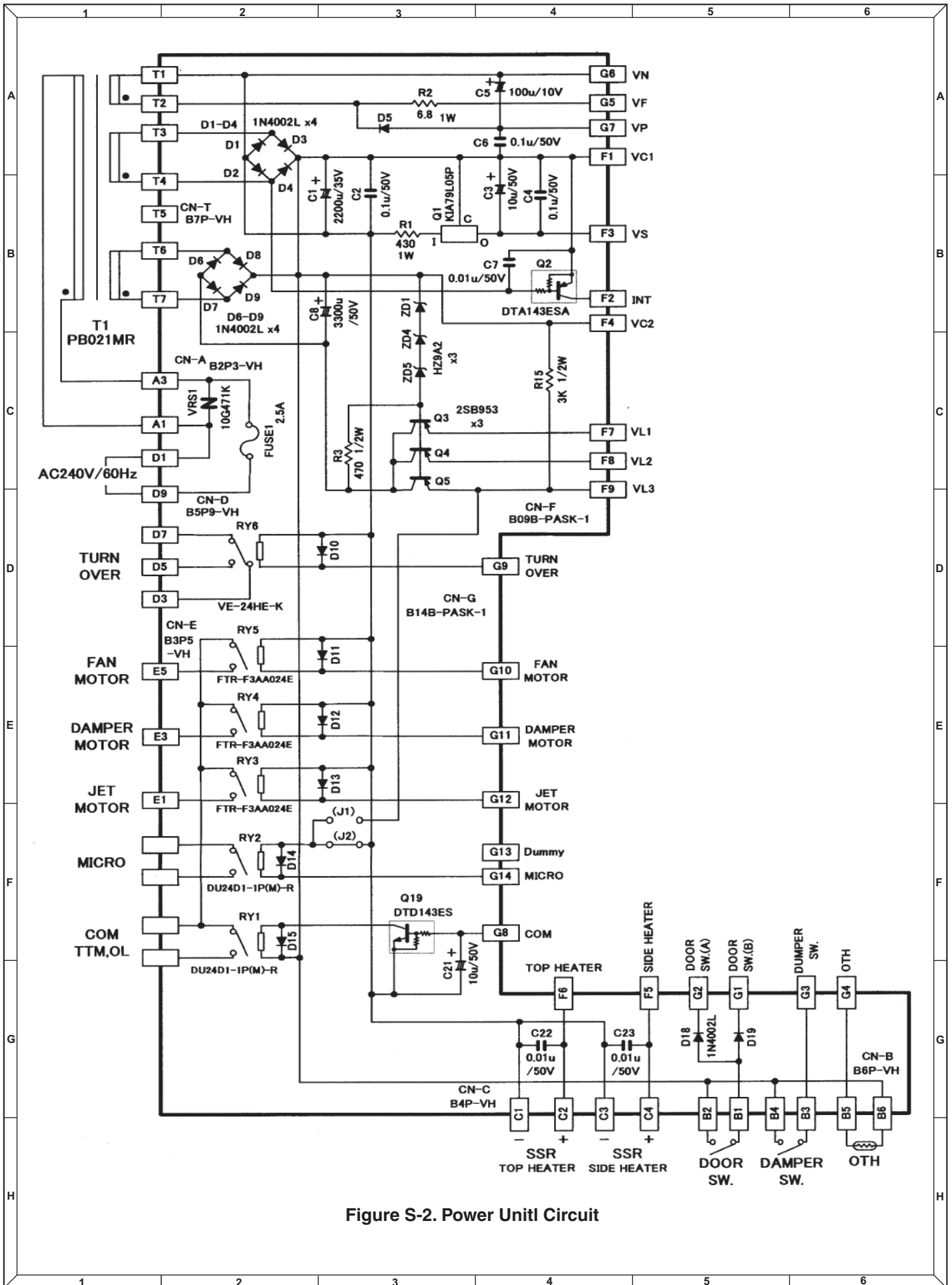

Figure S-2. Power Unit Circuit

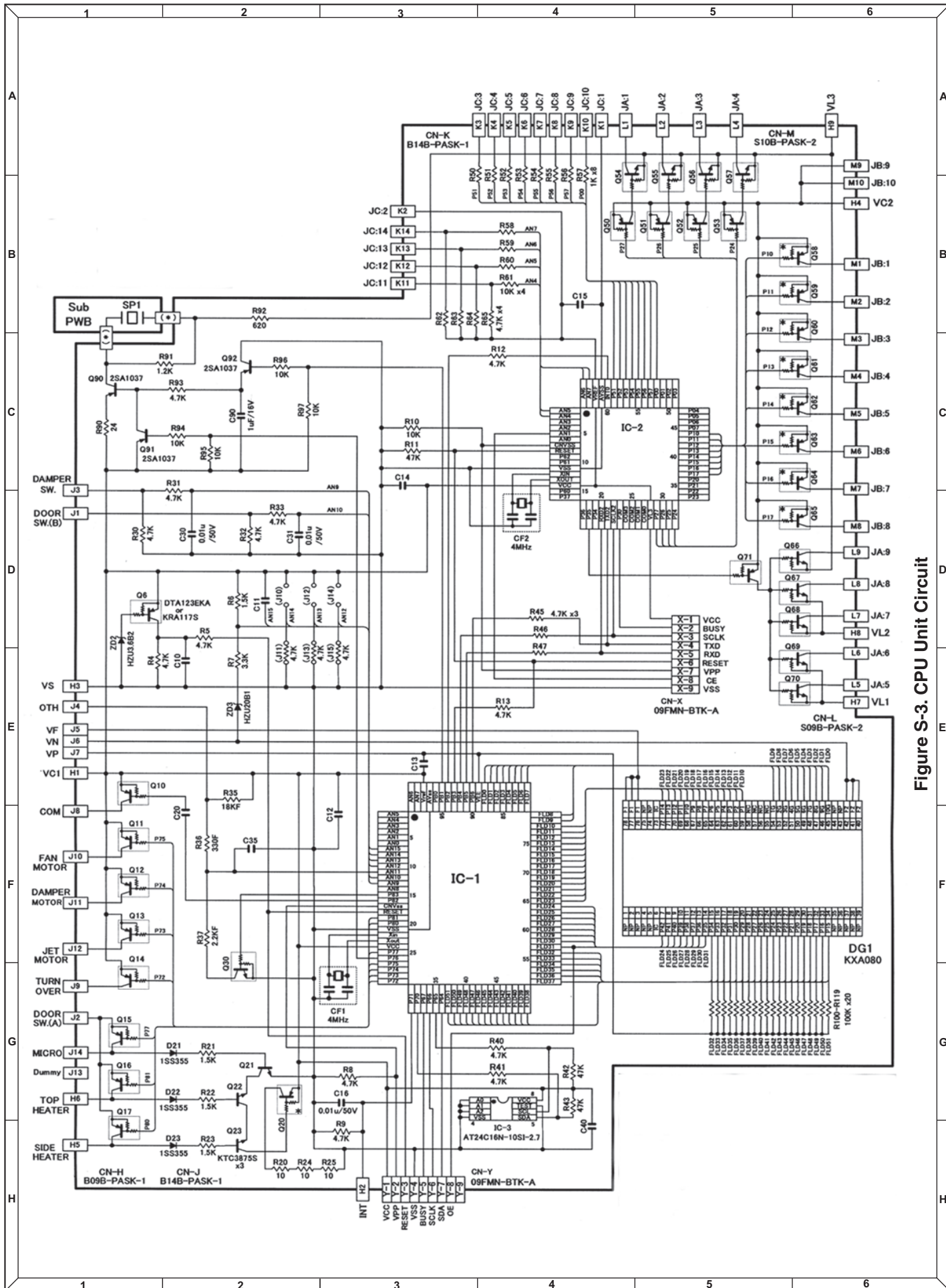

Figure S-3. CPU Unit Circuit

PARTS LIST

**Note: The parts marked "Δ" may cause undue microwave exposure.
The parts marked "*" are used in voltage more than 250V.**

REF. NO.	PART NO.	DESCRIPTION	
QTY			
ELECTRICAL PARTS			
1	QSW-MA085WRE0	Secondary interlock/door sensing/damper switch	3
2	RMOTDA191WRE0	Damper motor	1
3	RHET-A263WRZZ	Top heating element	1
4	RHET-A257WREZ	Side heating element	1
5	FH-HZA053WRE0	Thermistor	1
6	RMOTCA018WREZ	Convection motor	1
7	RMOTDA189WRE0	Turntable motor	1
8	FMOTEA459WRKZ	Fan motor assy	2
9	FACDDA113WREZ	Power supply cord	1
* 10	FH-DZA104WRKZ	High voltage rectifier assy	1
* 11	RC-QZA235WRE0	High voltage capacitor	1
* 12	FFS-BA033WRKZ	Monitor fuse 20A and monitor switch (V-5220Q) assembly	1
13	VHRG3NE22TL-1	Solid-state relay	2
14	QFS-CA026WRZZ	Fuse F10A	1
15	QFS-TA014WRE0	Temperature fuse 302°F (MG)	1
16	QFSHDA019WRE0	Fuse holder	1
17	RC-QZA324WRZZ	convection motor capacitor	1
18	RLMPTA083WRZZ	Oven lamp	1
19	RTHM-A109WRE0	Thermal cut out 338°F(Top heater) 338°F OFF 311°F ON	1
20	RTHM-A110WRE0	Thermal cut out 302°F(Side heater) 302°F OFF 266°F ON	1
* 21	RTRN-A678WRZZ	Power transformer	1
22	RTRNPB021MRE0	LV transformer	1
23	RV-MZA294WRE0	Magnetron	1
24	FPWBFA370WRKZ	Noise filter	1
CABINET PARTS			
25	GCABDA104WRPZ	Back plate	1
26	GDAI-A356WRWZ	Bottom plate	1
27	GLEGPA092WREZ	Leg	2
28	GCABUA976WRPZ	Outer case cabinet	1
CONTROL PANEL PARTS			
29	DPWFBFB139MRU0	Power unit (located on bottom plate)	1
30	DPWFBFB138MRU0	CPU unit	1
31	FUNTKB465MRK0	Key unit	1
32	LX-CZB033MRE0	Special screw	6
OVEN PARTS			
33	FDUC-A371WRKZ	Damper duct assembly	1
34	PZETEA084WRFZ	PWB mounting angle	1
35	LANGQA571WRPZ	Motor mounting angle	1
36	MCAMPA102WRFZ	Damper cam	1
37	NSFTTA143WREZ	Damper shaft	1
38	PCUSGA604WREZ	Damper cushion	1
39	PFTA-A033WRWZ	Damper	1
40	LANG-A097WRPZ	Catalyst angle	3
41	LANGFA242WRPZ	Heater mounting angle A	1
42	PDUC-A821WRTZ	Heater duct upper	1
43	PFIL-A020WREZ	Catalyst	3
44	LANGFA260WRPZ	Heater mounting angle B	1
45	PDUC-A822WRTZ	Heater duct left	1
46	FANGTA167WRKZ	Coupling assembly	1
47	FDUC-A369WRKZ	Exhaust duct	1
48	FFANMA016WRKZ	Convection fan assembly	1
49	LANGFA243WRPZ	Convection motor mounting angle	1
50	PDUC-A825WRPZ	Convection duct	1
51	PFPF-A229WREZ	Thermal insulator back	1
52	PREFHA072WRWZ	Thermal cover back	1
53	PSKR-A388WRWZ	Divide plate A	1
54	PSKR-A389WRWZ	Divide plate B	1
55	*****	Oven cavity (Not replaceable part)	1
56	LANG-A095WRPZ	Turntable mounting angle	1
57	LANGQA569WRPZ	Separator left	1
58	LANGQA590WRWZ	Lamp mounting angle	1
59	PSKR-A387WRPZ	Magnetron separator	1
60	PCUSUA601WREZ	Cushion	1

REF. NO.	PART NO.	DESCRIPTION	QTY
61	PCUSGA603WREZ	Cushion	2
62	PFPF-A225WRPZ	Thermal insulation L	1
63	PSKR-A377WRFZ	Rear separator	1
64	PFPF-A227WRPZ	Thermal insulation Upper	1
65	PFPF-A228WRPZ	Thermal insulation Bottom	1
66	PGLSPA579WRZZ	Lamp glass	1
67	PPACGA189WREZ	Silcon packing	1
68	PREFHA069WRPZ	Thermal cover Upper	1
69	PREFHA078WRWZ	Thermal cover Left	1
70	PREFHA071WRPZ	Thermal cover D	1
71	LANGQA572WRPZ	Fan motor mounting angle	1
72	LBNDKA158WRPZ	Capacitor holder	1
73	FHNG-A305WRYZ	Oven hinge Left	1
74	FHNG-A306WRYZ	Oven hinge Right	1
75	PHOK-A125WRFZ	Latch hook Right	1
76	PHOK-A126WRFZ	Latch hook Left	1
77	PDUC-B151MRP0	Top duct	1
78	LANG-A096WRPZ	Transformer mounting angle	1
79	LANGFA241WRWZ	Chassis support	2
80	LANGKB019WRWZ	Magnetron guide	1
81	MCAMPA115WRMZ	Door cam Left	1
82	MCAMPA116WRMZ	Door cam Right	1
83	MSPRTB027MRE0	Door spring	2
84	PCOVPA379WREZ	Waveguide cover	1
85	PCUSGA602WREZ	Cushion	1
86	HDECAB283MRT0	Vent extrusion	2
87	PCUSGA584WREZ	Cushion	2
88	PCUSUA589WREZ	Cushion	1
89	FDUC-B074MRK0	Bottom duct	1
90	PCUSUA591WREZ	Cushion	1
91	PCUSUA592WREZ	Cuhsion	2
92	PCOVPA389WREZ	Edge cover	3
93	PCUSUA614WREZ	Cushion	1
94	PCUSUA609WREZ	Cushion	1
95	PCUSUA610WREZ	Cushion	1
96	PCUSUA611WREZ	Cushion	1
97	PCUSUA612WREZ	Cushion	1
98	PCUSUA613WREZ	Cushion	1
99	LANGQA581WRPZ	Noise unit angle	1
100	HDECAB282MRT0	Side trim R	1
101	HDECAB281MRT0	Side trim L	1

DOOR PARTS

102	CDORFB437MRK0	Door assy	1
103	FHNDPB022MRK0	Door handle	1
104	LX-BZ0139WRE0	Screw	2
105	GCOVHA439WRFZ	Choke cover	1
106	LBRC-B009MRC0	Handle adapter left	1
107	LBRC-B010MRC0	Handle adapter right	1
108	LSTPPA224WREZ	Latch head Right	1
109	LSTPPA225WREZ	Latch head Left	1
110	MSPRCB002MRE0	Handle spring	2
111	MLEVFA089WRWZ	Handle lever	2
112	MSPRCA137WREZ	Latch spring Right	1
113	MSPRCA138WREZ	Latch spring Left	1
114	XEPS740P08000	Screw : 4mm x 8mm	14
115	XHTS740P10000	Screw : 4mm x 20mm	4
116	LPIN-A179WREZ	Handle pin	2

MISCELLANEOUS

117	FAMI-A120WRYZ	High rack assembly	1
118	FAMI-A121WRYZ	Low rack assembly	1
119	FROLPA105WRYZ	Turntable support	1
120	NTNT-A113WRHZ	Turntable tray	1
121	PSLD-A030WRHZ	Splash guard	1
122	TCADCB018MRR0	Cook book	1
123	TINSEB424MRR0	Instruction book	1
124	TINSEB470MRR0	User & care guide	1
125	FW-VZC055WREZ	Main wire harness	1
126	FW-VZB920WREZ	Thermistor harness	1
127	LBSHCA012WRE0	Cord bushing	1
128	LHLDWA012WRE0	Purse lock L	1
129	TCAUAB050MRR0	Monitor caution	1
130	TCAUAB048MRR0	DHHS caution label	1

REF. NO.	PART NO.	DESCRIPTION	Q'TY
131	TCAUHB008MRR0	User caution label	1
132	PZET-A011WRE0	Thermal insulator	1
133	LHLDWA029WRE0	Cord holder	1
134	LHLDWA013WRE0	Purse lock LL	1
135	*****	Shipping side angel L (Not replaceable part)	1
136	*****	Shipping side angel R (Not replaceable part)	1
137	FDUC-B080MRK0	Back duct	1
138	TCAUAB060MRR0	NHW caution label	1
139	TCAUHB014MRR0	French user caution label	1
140	TCAUSB012MRR0	BIK-height caution label	1

SCREWS, NUTS, WASHERS AND OTHER

141	XNEUW40-32000	Nut : 4mm x 3.2mm	4
142	XOTWW40P08000	Screw : 4 mm x 8 mm	55
143	XBTS740P06000	Screw : 4 mm x 6 mm	6
144	XHPS740P08K00	Screw : 4 mm x 8 mm	12
145	XHTS740P08RV0	Screw : 4mm x 8mm	4
146	XOPS740P08000	Screw : 4mm x 8mm	4
147	XOTS740P08000	Screw : 4mm x 8mm	5
148	XOTS740P12000	Screw : 4mm x 12mm	65
149	LX-CZA070WRE0	Special screw (Torx tamper proof screw)	2
150	PCUSUA237WRP0	Cushion	1
151	LX-EZA060WREZ	Special screw	4
152	XONSC40P10000	Screw	1
153	XHTS740P08000	Screw : 4mm x 8mm	3
154	LX-BZA144WREZ	Special screw	3
155	XOTS740P12RV0	Screw : 4mm x 12mm	1
156	LX-BZA143WREZ	Special screw	1
157	XEPS740P08000	Screw : 3 mm x 10 mm	1
158	XFPSD30P10000	Screw : 3 mm x 10 mm	11
159	LX-CZ0052WRE0	Special screw	1
160	XCPS740P08000	Screw : 4mm x 8mm	2
161	XCPD40P08000	Screw : 3mm x 14mm	2
162	LANGTB124MRP0	Clip retainer	2
163	CFZK-B766MRK0	Anti-tip bracket assy	2
164	TMAPCB102MRR0	Schematic	1
165	PCUSGA627WRPZ	Cushion	1
166	GCOVHA462WRPZ	Lamp cover	1
167	PCUSGA626WRPZ	Cushion	1
168	PCUSUA616WREZ	Cushion	1

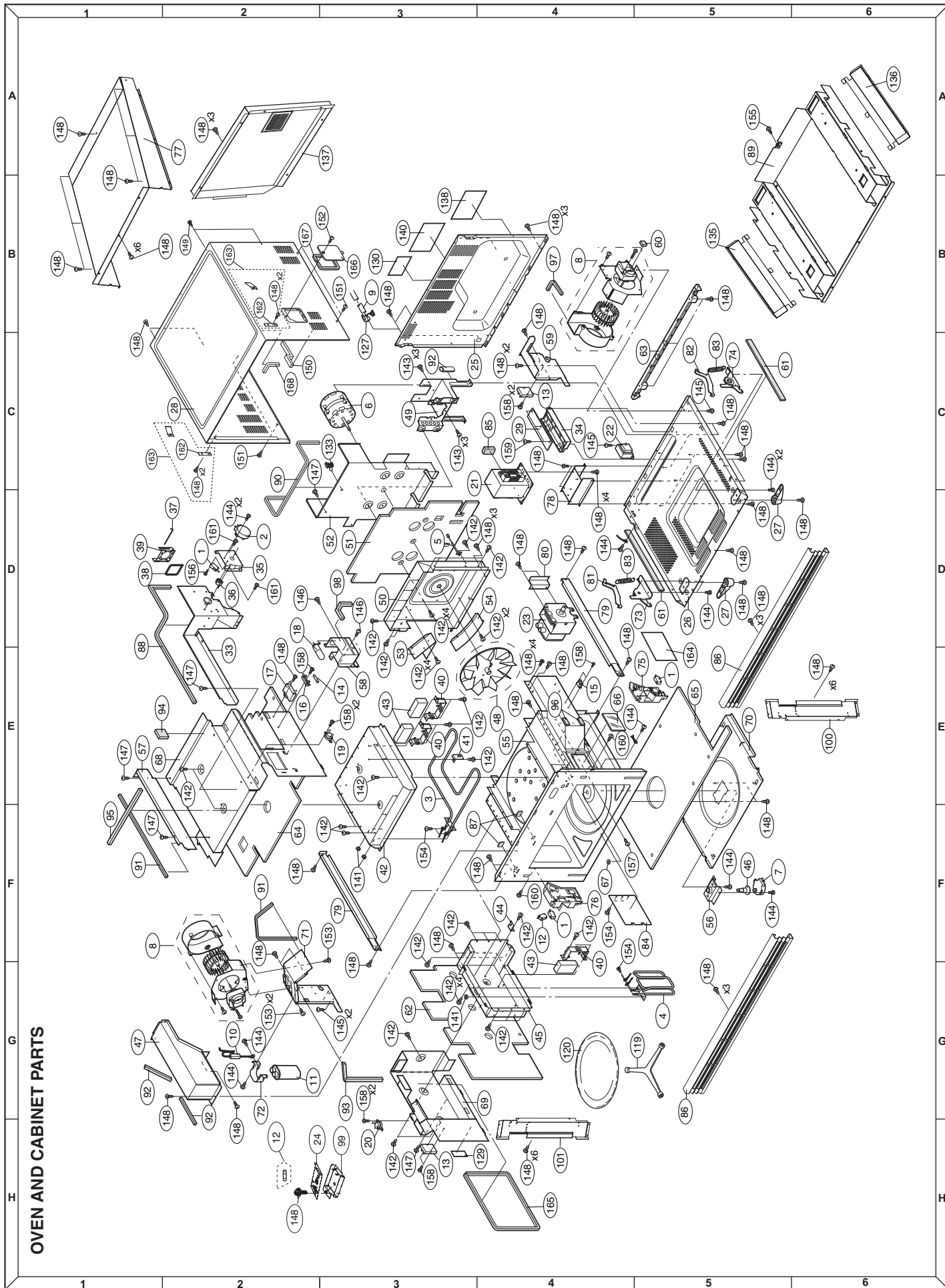

OVEN AND CABINET PARTS

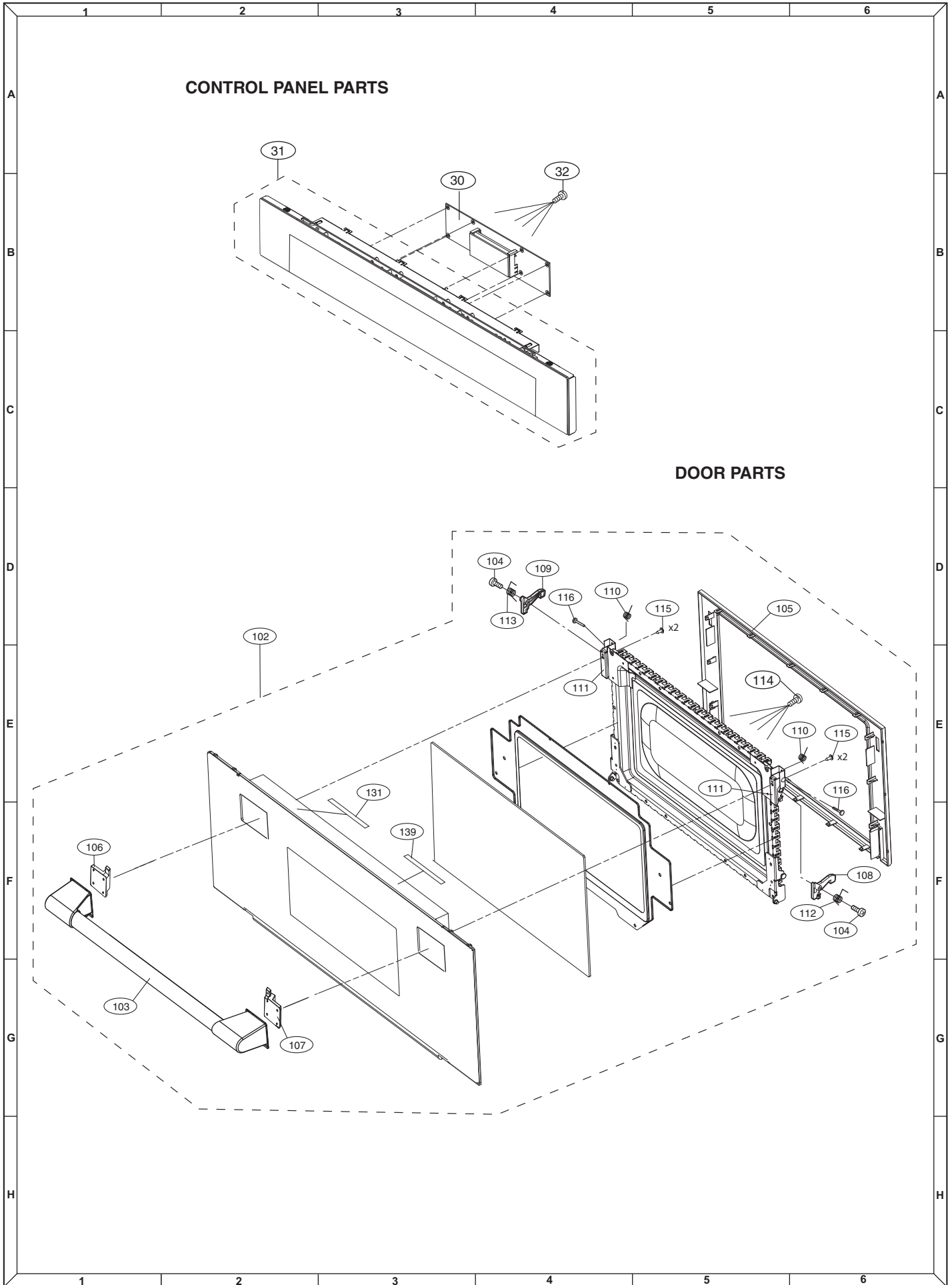

MISCELLANEOUS

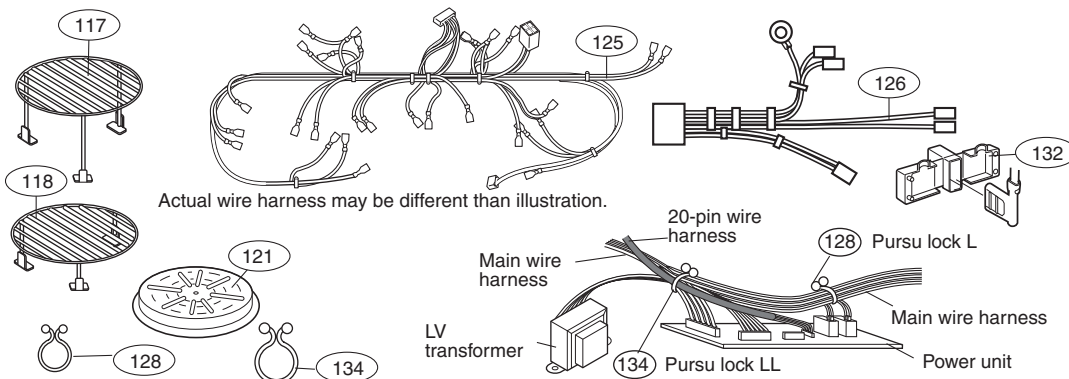

POSITION OF PURSE LOCK

PACKING AND ACCESSORIES

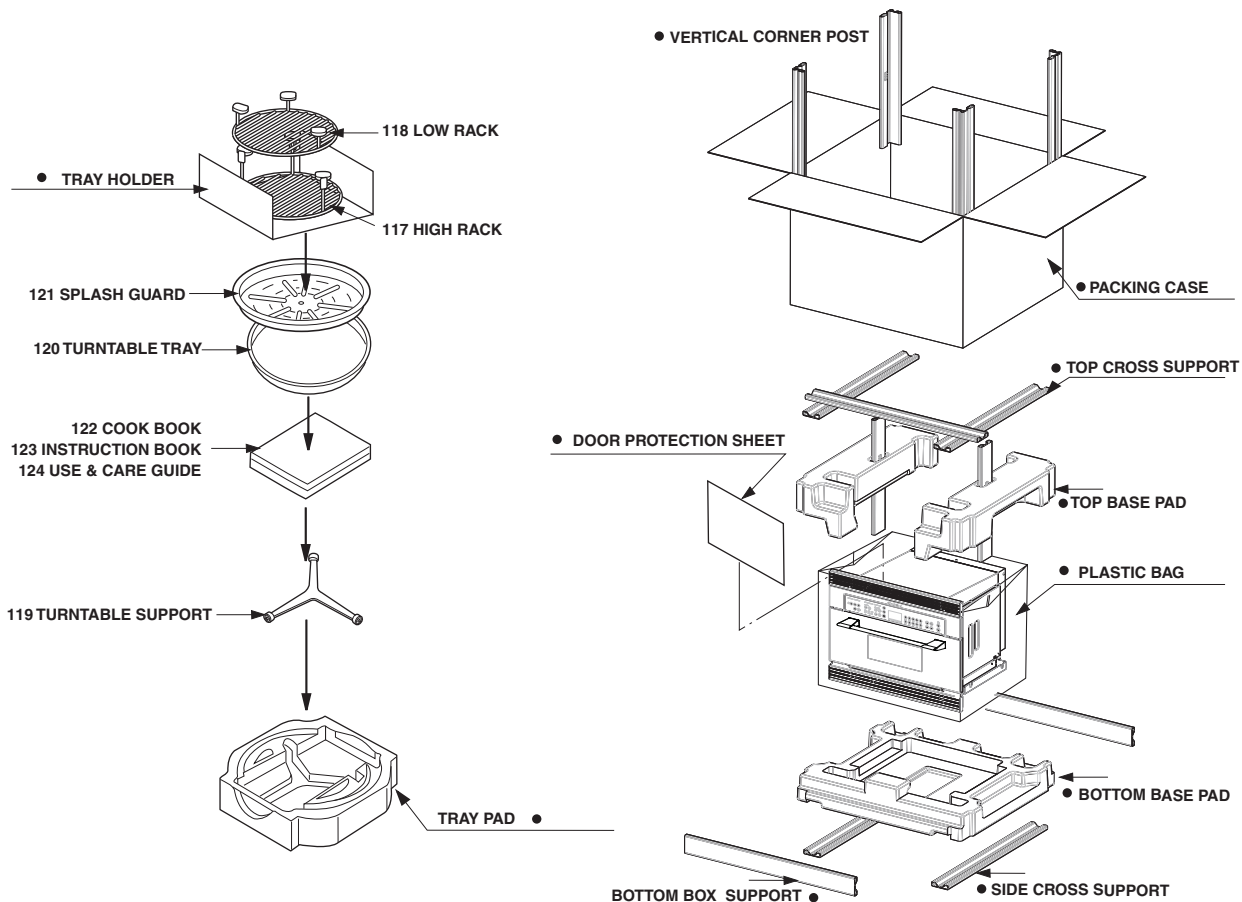

● Not replaceable items.

NOTES:

NOTES:

ELECTROLUX

COPYRIGHT © 2006 BY ELECTROLUX HOME PRODUCTS, INC.

ALL RIGHTS RESERVED.

No part of this publication may be reproduced, stored in retrieval systems, or transmitted in any form or by any means, electronic, mechanical, photocopying, recording, or otherwise, without prior written permission of the publisher.