

Technical Service Manual

Over The Range Microwave Oven



Models

EI30MH55GBA
EI30MH55GBB

EI30MH55GSA
EI30MH55GSB

EI30MH55GWA
EI30MH55GWB

EI30MH55GZA
EI30MH55GZB



Section 1

Basic Information

This Manual has been prepared to provide Electrolux Service Personnel with Operation and Service Information for following Electrolux Microwave Ovens:

EI30MH55GBA, EI30MH55GSA, EI30MH55GWA, EI30MH55GGB, EI30MH55GSB & EI30MH55GWB

Table of Contents

Section 1 Basic Information	1-1	Stirrer Motors Replacement	4-10
Table of Contents	1-2	Stirrer Fan Assembly Installation	4-10
Safe Servicing Practices	1-2	Hood Lamp Sockets Removal	4-10
Warnings and Safety Information	1-3	Oven Lamp and Lamp Socket Removal	4-11
Precautions To Be Observed Before And During Servicing To Avoid Possible Exposure To Excessive Microwave Energy	1-5	Positive Lock ® Connector (No-Case Type)	4-11
Before Servicing	1-5	Control Panel Assembly, Control Unit and Key Unit Removal	4-11
Danger Caution High Voltage Before Servicing	1-5	Humidity Sensor Removal	4-12
Servicing the Inverter Unit	1-6	Noise Filter Removal	4-12
Microwave Measurement Procedure	1-7	Table Tray Assembly Removal	4-12
Product Specification	1-8	Stop Switch, Primary Interlock Switch, Secondary Interlock Switch and Monitor Switch	4-13
Grounding Instructions	1-9	Stop Switch, Primary Interlock Switch, Secondary Interlock Switch and Monitor Switch Adjustment	4-14
Oven Diagram	1-10	Door Replacement	4-15
Section 2 Operation	2-1	Section 5 Wire Diagrams	5-1
Operating Sequence Description	2-2	Pictorial Diagram	5-2
Hot Air Exhaust Ventilation Methods	2-4	Power Unit Circuit	5-3
Oven Schematic-Off Condition	2-5	LSI Unit Circuit	5-4
Oven Schematic-Cooking Condition	2-5	Printed Wiring Board	5-5
Component Descriptions	2-6	Component Descriptions	2-6
Touch Control Panel Operation	2-7	Touch Control Panel Operation	2-7
Description of LSI	2-8	Description of LSI	2-8
Humidity Sensor Circuit	2-11	Humidity Sensor Circuit	2-11
Section 3 Troubleshooting and Testing	3-1	Section 6 Parts List	6-1
Troubleshooting Guide	3-2	Parts List	6-2
Troubleshooting Guide Chart	3-3	Oven Parts Exploded View	6-4
Test Procedures	3-4	Cabinet Parts Exploded View	6-5
 		Door Parts Exploded View	6-6
Section 4 Component Teardown	4-1	Packing and Accessories	6-7
Servicing	4-2		
Precautions for Using Lead-Free Solder	4-3		
Warnings	4-4		
Hood Louver Removal	4-6		
Outer Case Removal	4-6		
Hood Fan Motor Removal	4-6		
Magnetron Removal	4-7		
Hood Fan Thermal Cut-out Removal	4-7		
Oven Thermal Cut-out Removal	4-7		
Inverter Unit and Fan Motor Replacement	4-8		
Method for Removing Fan Blade	4-9		
Method for Installing Fan Blade	4-9		

Safe Servicing Practices

Avoid personal injury and/or property damage by observing important Safe Servicing Practices. Following are some limited examples of safe practices:

1. DO NOT attempt a product repair if you have any doubts as to your ability to complete the repair in a safe and satisfactory manner.
2. Always Use The Correct Replacement Parts as indicated in the parts documentation. Substitutions may defeat compliance with Safety Standards Set For Home Appliances. Do not exceed maximum recommended wattage on light bulb replacements. Doing so could blow fuses and/or damage transformers.
3. Before servicing or moving an appliance:
 - Remove power cord from the electrical outlet, trip circuit breaker to the OFF position, or remove fuse.
4. Never interfere with the proper operation of any safety device.
5. Use ONLY REPLACEMENT PARTS CATALOGED FOR THIS APPLIANCE. Substitutions may defeat compliance with Safety Standards Set For Home Appliances.
6. GROUNDING: The standard color coding for safety ground wires is GREEN, or GREEN with YELLOW STRIPES. Ground leads are not to be used as current carrying conductors. It is EXTREMELY important that the service technician reestablish all safety grounds prior to completion of service. Failure to do so will create a hazard.
7. Prior to returning the product to service, ensure that:
 - All electrical connections are correct and secure.
 - All electrical leads are properly dressed and secured away from sharp edges, high-temperature components, and moving parts.
 - All non-insulated electrical terminals, connectors, heaters, etc. are adequately spaced away from all metal parts and panels.
 - All safety grounds (both internal and external) are correctly and securely connected.
 - All panels are properly and securely reassembled.

© 2008 Electrolux Home Products, Inc.

WARNING

CERTAIN INITIAL PARTS ARE INTENTIONALLY NOT GROUNDED AND PRESENT A RISK OF ELECTRICAL SHOCK ONLY DURING SERVICING. SERVICE PERSONNEL - DO NOT CONTACT THE FOLLOWING PARTS WHILE THE APPLIANCE IS ENERGIZED;

INVERTER UNIT, HIGH VOLTAGE POWER TRANSFORMER, HIGH VOLTAGE RECTIFIER, HEAT SINK, MAGNETRON, HIGH VOLTAGE HARNESS ETC.;

IF PROVIDED, VENT HOOD, FAN ASSEMBLY, COOLING FAN MOTOR.

ALL THE PARTS MARKED “*” ON PARTS LIST ARE USED AT VOLTAGES MORE THAN 250V.

REMOVAL OF THE OUTER WRAPPER GIVES ACCESS TO VOLTAGE ABOVE 250V.

ALL THE PARTS MARKED “Δ” ON PARTS LIST MAY CAUSE UNDUE MICROWAVE EXPOSURE, BY THEMSELVES, OR WHEN THEY ARE DAMAGED, LOOSENED OR REMOVED.

WARNING

THIS SERVICE MANUAL IS INTENDED FOR USE BY PERSONS HAVING ELECTRICAL AND MECHANICAL TRAINING AND A LEVEL OF KNOWLEDGE OF THESE SUBJECTS GENERALLY CONSIDERED ACCEPTABLE IN THE APPLIANCE REPAIR TRADE. ELECTROLUX HOME PRODUCTS CANNOT BE RESPONSIBLE, NOR ASSUME ANY LIABILITY, FOR INJURY OR DAMAGE OF ANY KIND ARISING FROM THE USE OF THIS MANUAL.

WARNING

NEVER OPERATE THE OVEN UNTIL THE FOLLOWING POINTS ARE ENSURED.

(A) THE DOOR IS TIGHTLY CLOSED.

(B) THE DOOR BRACKETS AND HINGES ARE NOT DEFECTIVE.

(C) THE DOOR PACKING IS NOT DAMAGED.

(D) THE DOOR IS NOT DEFORMED OR WARPED.

(E) THERE IS NO OTHER VISIBLE DAMAGE WITH THE OVEN.

SERVICING AND REPAIR WORK MUST BE CARRIED OUT ONLY BY TRAINED SERVICE PERSONNEL.

Precautions To Be Observed Before And During Servicing To Avoid Possible Exposure To Excessive Microwave Energy

- (a) Do not operate or allow the oven to be operated with the door open.
- (b) Make the following safety checks on all ovens to be serviced before activating the magnetron or other microwave source, and make repairs as necessary: (1) interlock operation, (2) proper door closing, (3) seal and sealing surfaces (arcing, wear, and other damage), (4) damage to or loosening of hinges and latches, (5) evidence of dropping or abuse.
- (c) Before turning on microwave power for any service test or inspection within the microwave generating compartments, check the magnetron, wave guide or transmission line, and cavity for proper alignment, integrity, and connections.
- (d) Any defective or misadjusted components in the interlock, monitor, door seal, and microwave generation and transmission systems shall be repaired, replaced, or adjusted by procedures described in this manual before the oven is released to the owner.
- (e) A microwave leakage check to verify compliance with the Federal Performance Standard should be performed on each oven prior to release to the owner.

Before Servicing

Before servicing an operative unit, perform a microwave emission check as per the Microwave Measurement Procedure outlined in this service manual.

If microwave emissions level is in excess of the specified limit, contact Electrolux HOME PRODUCTS, INC. immediately.

If the unit operates with the door open, service person should 1) tell the user not to operate the oven and 2) contact Electrolux HOME PRODUCTS, INC. and Food and Drug Administration's Center for Devices and Radiological Health immediately.

Service personnel should inform Electrolux HOME PRODUCTS, INC. of any certified unit found with emissions in excess of 4mW/cm². The owner of the unit should be instructed not to use the unit until the oven has been brought into compliance.

Danger Caution HIGH VOLTAGE

Do not energize a microwave oven with the outer case cabinet removed, because a microwave oven generates High Voltage in the circuit.

If you intend to operate the oven employing the high frequency switching power converter circuit, you should take special precautions to avoid an electrical shock hazard.

The high voltage transformer and high voltage diode have energized high voltage potential approx. 8 KV.

The aluminum heat sink is connected to the switching power transistor collector pole, and has an energized high voltage potential of approx. 650V peak.

DO NOT ACCESS THE HIGH VOLTAGE TRANSFORMER , HIGH VOLTAGE DIODE AND HEAT SINK WHEN THE POWER SUPPLY IS CONNECTED TO AN ELECTRICAL OUTLET.

WARNING

MICROWAVE OVENS CONTAIN CIRCUITRY CAPABLE OF PRODUCING VERY HIGH VOLTAGE AND CURRENT, CONTACT WITH FOLLOWING PARTS MAY RESULT IN A SEVERE, POSSIBLY FATAL, ELECTRICAL SHOCK.

(EXAMPLE)

INVERTER UNIT THAT INCLUDES HIGH VOLTAGE POWER TRANSFORMER, HIGH VOLTAGE RECTIFIER, HEAT SINK ETC., AND MAGNETRON, HIGH VOLTAGE HARNESS ETC..

READ THE SERVICE MANUAL CAREFULLY AND FOLLOW ALL INSTRUCTIONS.

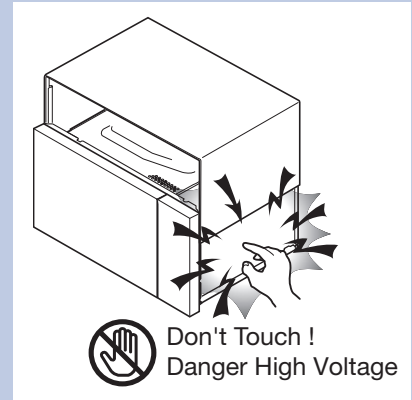

Before Servicing

1. Disconnect the power supply cord , and then remove outer case.
2. Open the door and block it open.

Whenever troubleshooting is performed the power supply must be disconnected. It may, in some cases, be necessary to connect the power supply after the outer case has been removed, in this event:

1. Disconnect the power supply cord, and then remove outer case.
2. Open the door and block it open.
3. Disconnect the leads to the primary of the inverter unit.
4. Ensure that these leads remain isolated from other components and oven chassis by using insulation tape.
5. After that procedure, reconnect the power supply cord.

When the testing is completed,

1. Disconnect the power supply cord, and then remove outer case.
2. Open the door and block it open.
3. Reconnect the leads to the primary of the inverter unit.
4. Reinstall the outer case (cabinet).
5. Reconnect the power supply cord after the outer case is installed.
6. Run the oven and check all functions.

After repairing

1. Reconnect all leads removed from components during testing.
2. Reinstall the outer case (cabinet).
3. Reconnect the power supply cord after the outer case is installed.
4. Run the oven and check all functions.
Microwave ovens should not be run empty. To test for the presence of microwave energy within a cavity, place a cup of cold water on the oven turntable, close the door and set the power to HIGH and set the microwave timer for two (2) minutes. When the two minutes has elapsed (timer at zero) carefully check that the water is now hot. If the water remains cold carry out Before Servicing procedure and re-examine the connections to the component being tested.

Servicing the Inverter Unit

WARNING

THIS INVERTER UNIT CONTAINS CIRCUITRY CAPABLE OF PRODUCING HIGH VOLTAGE AND HIGH CURRENT. CONTACT WITH ANY PART OF THE HIGH VOLTAGE WILL RESULT IN ELECTROCUTION. DO NOT ACCESS ANY PARTS OF INVERTER UNIT WITH POWER SUPPLY CONNECTED. DO NOT OPERATE INVERTER UNIT ITSELF. IT IS DANGEROUS BECAUSE THIS UNIT CONTAINS HIGH VOLTAGE COMPONENTS.

Microwave Measurement Procedure

A. Requirements:

- 1) Microwave leakage limit (Power density limit): The power density of microwave radiation emitted by a microwave oven should not exceed 1 mW/cm² at any point 5cm or more from the external surface of the oven, measured prior to acquisition by a purchaser, and thereafter (through the useful life of the oven), 5 mW/cm² at any point 5cm or more from the external surface of the oven.
- 2) Safety interlock switches: Primary interlock switch shall prevent microwave radiation emission in excess of the requirement as above mentioned, secondary interlock switch shall prevent microwave radiation emission in excess of 5 mW/cm² at any point 5cm or more from the external surface of the oven.

B. Preparation for testing:

Before beginning the actual measurement of leakage, proceed as follows:

- 1) Make sure that the actual instrument is operating normally as specified in its instruction booklet.
Important:
Survey instruments that comply with the requirement for instrumentation as prescribed by the performance standard for microwave ovens, 21 CFR 1030.10(c)(3)(i), must be used for testing.
- 2) Place the oven tray in the oven cavity.
- 3) Place the load of 275±15 ml (9.8 oz) of tap water initially at 20±5C (68±5F) in the center of the oven cavity. The water container shall be a low form of 600 ml (20 oz) beaker with an inside diameter of approx. 8.5 cm (3-1/2 in.) and made of an electrically nonconductive material such as glass or plastic. The placing of this standard load in the oven is important not only to protect the oven, but also to insure that any leakage is measured accurately.
- 4) Set the cooking control on Full Power Cooking Mode
- 5) Close the door and select a cook cycle of several minutes. If the water begins to boil before the survey is completed, replace it with 275 ml of cool water.

C. Leakage test:

Closed-door leakage test (microwave measurement)

- 1) Grasp the probe of the survey instrument and hold it perpendicular to the gap between the door and the body of the oven.
- 2) Move the probe slowly, not faster than 1 in./sec. (2.5 cm/sec.) along the gap, watching for the maximum indication on the meter.
- 3) Check for leakage at the door screen, sheet metal seams and other accessible positions where the continuity of the metal has been breached (eg., around the switches, indicator, and vents).
While testing for leakage around the door pull the door away from the front of the oven as far as is permitted by the closed latch assembly.
- 4) Measure carefully at the point of highest leakage and make sure that the highest leakage is no greater than 4mW/cm², and that the primary interlock switch and secondary interlock switch do turn the oven OFF before any door movement.

NOTE: After servicing, record data on service invoice and microwave leakage report.

Product Specification

Item	Description
Power Requirements	120 Volts / 12 Amperes 60 Hertz Single phase, 3 wire grounded
Power Output	1200 watts (IEC TEST PROCEDURE) Operating frequency of 2450MHz
Case Dimensions	Width 29-15/16" Height 17" Depth 15- 9/16"
Cooking Cavity Dimensions 2.1 Cubic Feet	Width 22-9/16" Height 10-9/16" Depth 15"
Hood lamp	2 bulbs, 20W x 2, Incandescent light bulbs
Hood fan	Approx. High - 300 C.F.M. / Low - 270 C.F.M.
Control Complement	Touch Control System Clock (1:00 - 12:59) Timer (0 - 99 min. 99 seconds) Microwave Power for Variable Cooking Repetition Rate; P-HI Full power throughout the cooking time P-90 approx. 90% of Full Power P-80 approx. 80% of Full Power P-70 approx. 70% of Full Power P-60 approx. 60% of Full Power P-50 approx. 50% of Full Power P-40 approx. 40% of Full Power P-30 approx. 30% of Full Power P-20 approx. 20% of Full Power P-10 approx. 10% of Full Power P-0 No power throughout the cooking time Quick Breakfast, Express Lunch, Dinner Recipes, Popcorn, Reheat, Soften, Melt, Warm, Keep Warm, Cook, Defrost, Power Level, Number selection pads, Power Level pad, Timer/Clock pad, Stop/Clear pad, User Pref, Start Add a Minute pad, Light, Fan
Oven Cavity Light	20W x 1 Incandescent light bulb
Safety Standard	UL Listed FCC Authorized DHHS Rules, CFR, Title 21, Chapter 1, Subchapter J Canadian Standards Association Health CANADA, Industry Canada
Weight	Approx. 44 lbs.

Grounding Instructions

This oven is equipped with a three prong grounding plug. It must be plugged into a wall receptacle that is properly installed and grounded in accordance with the National Electrical Code and local codes and ordinances.

In the event of an electrical short circuit, grounding reduces the risk of electric shock by providing an escape wire for the electric current.

WARNING

IMPROPER USE OF THE GROUNDING PLUG CAN RESULT IN A RISK OF ELECTRIC SHOCK.

Electrical Requirements

The oven is equipped with a 3-prong grounding plug. **DO NOT UNDER ANY CIRCUMSTANCES CUT OR REMOVE THE GROUNDING PIN FROM THE PLUG.** The power supply cord and plug must be connected to a separate 120 Volt AC, 60 Hz, 15 Amp or more dedicated line, using a grounded receptacle. The receptacle should be located inside the cabinet directly above the Microwave Oven/Hood system mounting location.

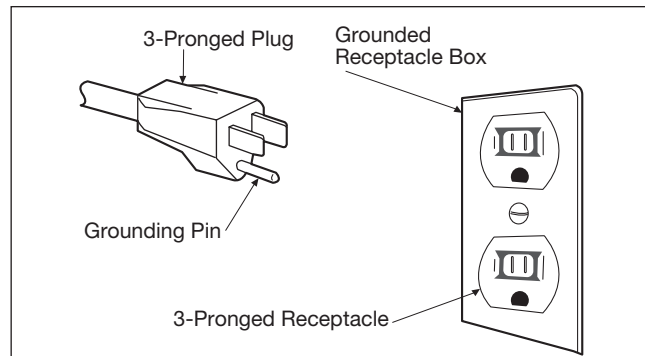
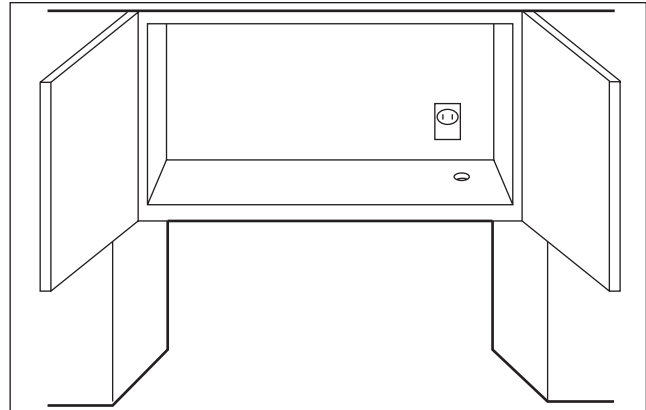

Oven Diagram

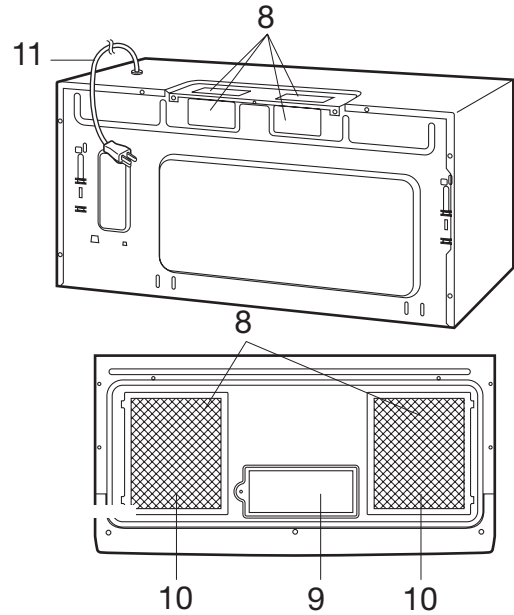
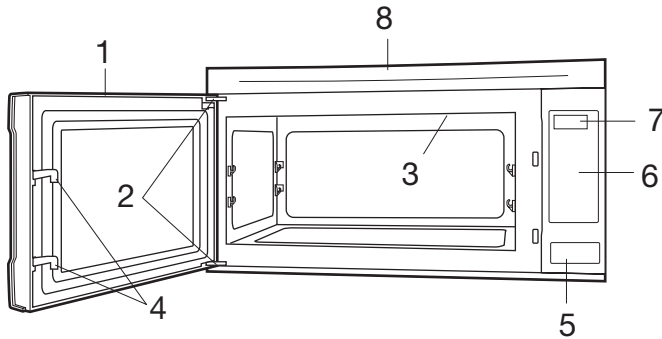

1. Oven door with see-through window.
2. Door hinges.
3. Oven lamp.
It will light when oven is operating or door is open.
4. Door latches.
The oven will not operate unless the door is securely closed.
5. One touch door open button
6. Auto-Touch control panel.
7. Timer display: Digital display, 99 minutes 00 seconds.
8. Ventilation openings.
9. Light Cover.
10. Grease filters.
11. Power supply cord



NOTE: Some one-touch cooking features such as "ADD A MINUTE" are disabled after three minutes when the oven is not in use. These features are automatically enabled when the door is opened and closed or the STOP/CLEAR pad is pressed.

Section 2

Operation

Operating Sequence Description

The following is a description of component functions during oven operation.

OFF CONDITION

Closing the door activates the stop switch, primary interlock switch and secondary interlock switch. (In this condition, the monitor switch contacts are opened.) When oven is plugged in, 120 volts A.C. is supplied to the control unit. (Figure O-1).

1. The display will show "Enjoy your oven, press clear and press clock". To set any program or set the clock, you must first touch the STOP/CLEAR button. The display will clear, and " : " appears.

COOKING CONDITION

Program desired cooking time touching the NUMBER pads. When the START button is touched, the following operations occur:

1. The contacts of relays are closed and components connected to the relays are turned on as follows. (For details, refer to Figure O-2)

RELAY	CONNECTED COMPONENTS
RY1	Oven lamp / Fan motor / Stirrer motor
RY3, RY4	Hood fan motor

2. 120 volts A.C. is supplied to the inverter unit and is converted in order to power of the magnetron by the high frequency switching power circuit. The frequency is approx. 33-45 KHz.
3. The filament winding voltage of H.V. transformer heats the magnetron filament and H.V. winding gives a high voltage approx. 2 KV to activate a voltage doubler circuit. Then approx. 4KV peak voltage power is supplied to the magnetron cathode terminal.
4. The microwave energy produced by the magnetron is channeled through the waveguide into the cavity feedbox, and then into the cavity where the food is placed to be cooked.
5. Upon completion of the cooking time, the inverter unit, oven lamp, etc. are turned off, and the generation of microwave energy is stopped. The oven will revert to the OFF condition.

6. When the door is opened during a cook cycle, the monitor switch, stop switch, secondary interlock switch and primary interlock switch are activated with the following results. The circuits to the stirrer motor, the cooling fan motor, the turntable motor, and the inverter unit are de-energized, and the touch screen displays the time still remaining in the cook cycle when the door was opened.
7. The monitor switch is electrically monitoring the operation of the secondary interlock switch and primary interlock switch and is mechanically associated with the door so that it will function in the following sequence.
 - (1) When the door opens from a closed position, the primary interlock switch and secondary interlock switch open their contacts, and then the monitor switch contacts close. And contacts of the relay (RY1) remain closed.
 - (2) When the door is closed from the open position, the monitor switch contacts first open and the stop switch contacts open, and then the contacts of the secondary interlock switch and primary interlock switch close. And contacts of the relay (RY1) open.

If the secondary interlock switch and primary interlock switch fail with their contacts closed when the door is opened, the closing of the monitor switch contacts will form a short circuit through the monitor fuse, secondary interlock switch, primary interlock switch and relay (RY1) causing the monitor fuse to blow.

VARIABLE COOKING

When Variable Cooking Power is programmed, the 120 volts A.C. is supplied to the inverter unit which is operated by the control unit. Microwave power operation is as follows:

The oven can be set for any of 11 power levels: 0% to 100%(HIGH). The variable cooking power less than 40% is programmed at the ratio of ON time and OFF time within 32 sec./ cycle time base.

Connection between power setting and ON/OFF time of inverter unit.

OUTPUT POWER SETTING	ON TIME	OFF TIME
Power 100%		
Power 90%		
Power 80%		
Power 70%		Continue operation
Power 60%		
Power 50%		
Power 40%	26 sec.	6 sec.
Power 30%	22 sec.	10 sec.
Power 20%	16 sec.	16 sec.
Power 10%	8 sec.	24 sec.
Power 0%	0 sec.	32 sec.

NOTE: The ON/OFF time ratio does not correspond with the percentage of microwave power, because approx. 3 seconds are needed for heating of the magnetron filament.

SENSOR COOKING CONDITION

Using the Sensor cooking function the food is cooked without figuring time, power level or quantity. When the oven senses enough steam from the food, it relays the information to its microprocessor which will calculate the remaining cooking time and power level needed for best results. When the food is cooked, water vapor is developed. The sensor "senses" the vapor and its resistance increases gradually. When the resistance reaches the value set according to the menu, supplementary cooking is started. The time of supplementary cooking is determined by experiment with each food category and input into the LSI.

An example of how the sensor works:
(BAKED POTATOES)



1. Potatoes at room temperature. Vapor is emitted very slowly.

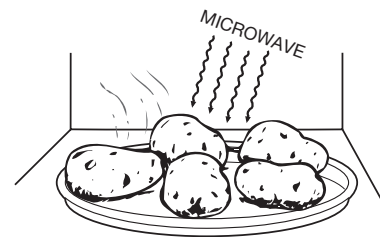

2. Heat Potatoes. Moisture and humidity is emitted rapidly. You can smell the aroma as it cooks.

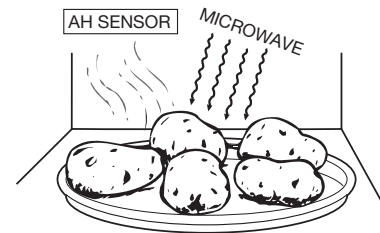

3. Sensor detects moisture and humidity and calculates cooking time and variable power.

Cooking Sequence.

1. Operate the oven in sensor cooking mode by referring to the operation manual.

NOTE: The oven should not be operated on SENSOR immediately after plugging in the unit. Wait two minutes before cooking on SENSOR.

2. The coil of shut-off relay (RY-1) is energized, the turntable motor, oven lamp and cooling fan motor are turned on, but the inverter unit is not turned on.
3. After about 32 seconds, the cook relay (RY-2) is energized. The power transformer is turned on, microwave energy is produced and first stage is started. The 32 seconds is the cooling time required to remove any vapor from the oven cavity and sensor.

NOTE: During this first stage, do not open the door or touch STOP/CLEAR pad.

4. When the sensor detects the vapor emitted from the food, the display switches over to the remaining cooking time and the timer counts down to zero. At this time, the door may be opened to stir, turn, or season food.
5. When the timer reaches zero, an audible signal sounds. The shut-off relay is de-energized and the inverter unit, oven lamp, etc. are turned off.
6. Opening the door or touching the STOP/CLEAR pad, the time of day will reappear on the display and the oven will revert to an OFF condition.

Hot Air Exhaust Ventilation Methods

1. VERTICAL VENTING

For this venting method, hot air rising from the conventional range below is drawn in by the hood fan motor through the grease filters at the right and left sides of the base cover, up through the right and left sides of the oven cavity, then discharged vertically at rear center top of the oven, into the customer's vent system.

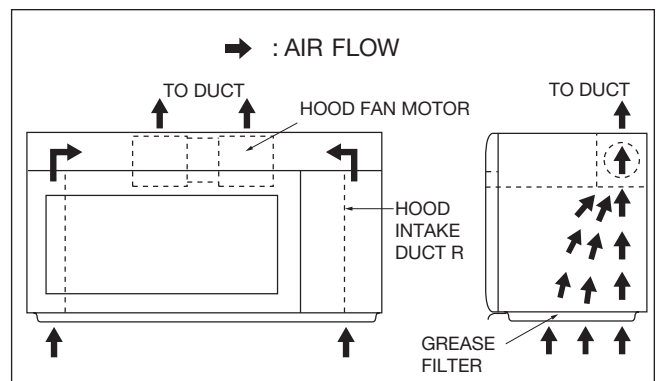

2. HORIZONTAL VENTING

The air handling is the same as VERTICAL VENTING except that the final air discharge is directed horizontally out from the top rear of the oven into the customer's vent system.

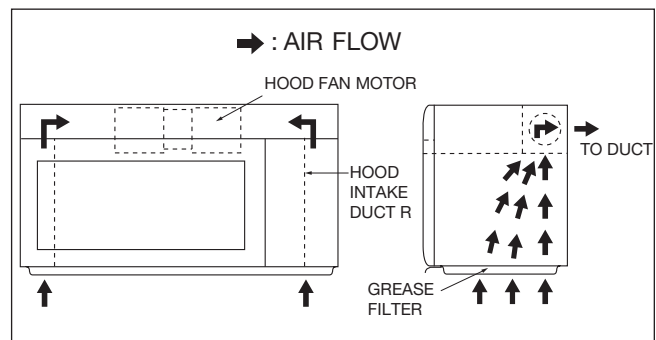

3. RE-CIRCULATION (INSIDE VENTING)

The air handling is the same as VERTICAL VENTING except that the final air discharge is directed horizontally through the upper front of the oven into the kitchen. In this case, the accessory charcoal filter RK-260 must be provided to filter the air before it leaves the oven.

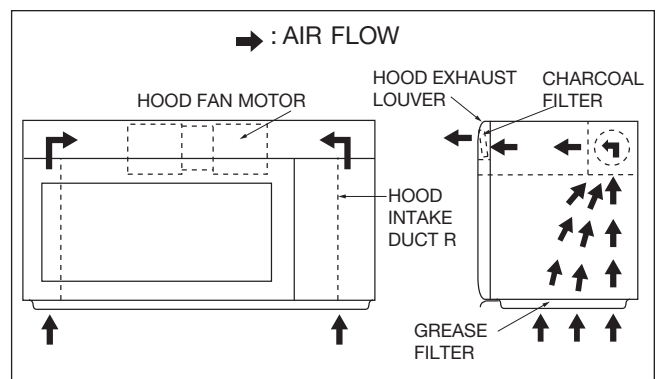

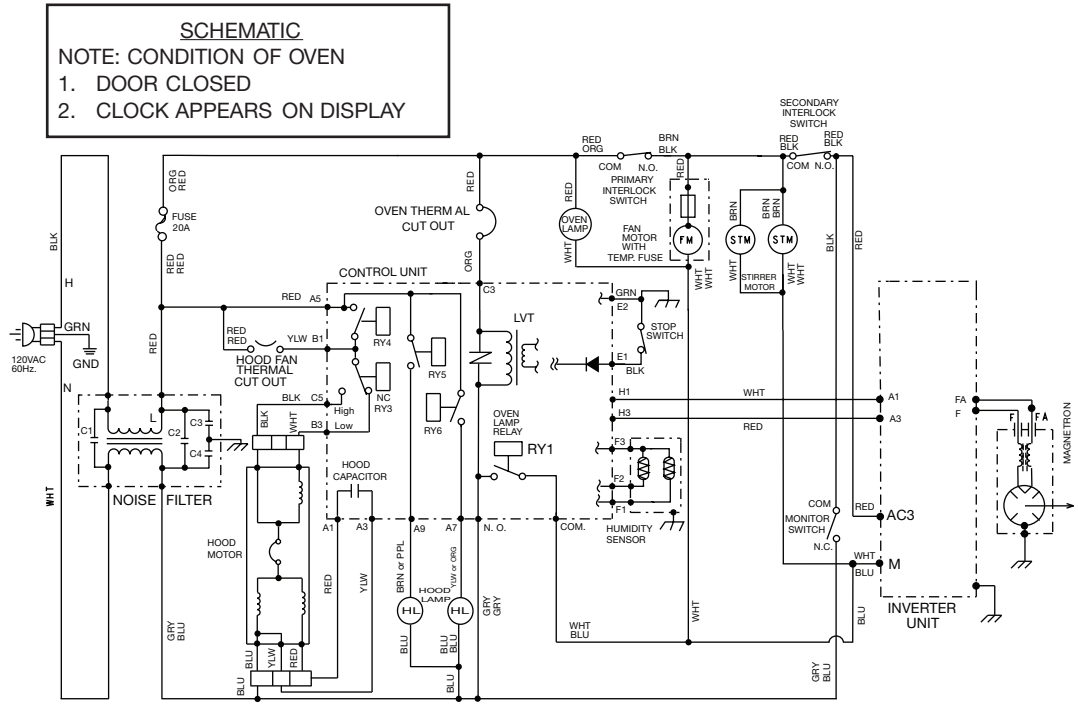

- NOTES:
1. Circuits / Wire Colors subject to change without notice.
 2. Terminal that located to the right side on the lamp socket's back view must be connected to neutral wire.
 3. Only certain models use the absolute humidity sensor

Figure O-1. Oven Schematic-Off Condition

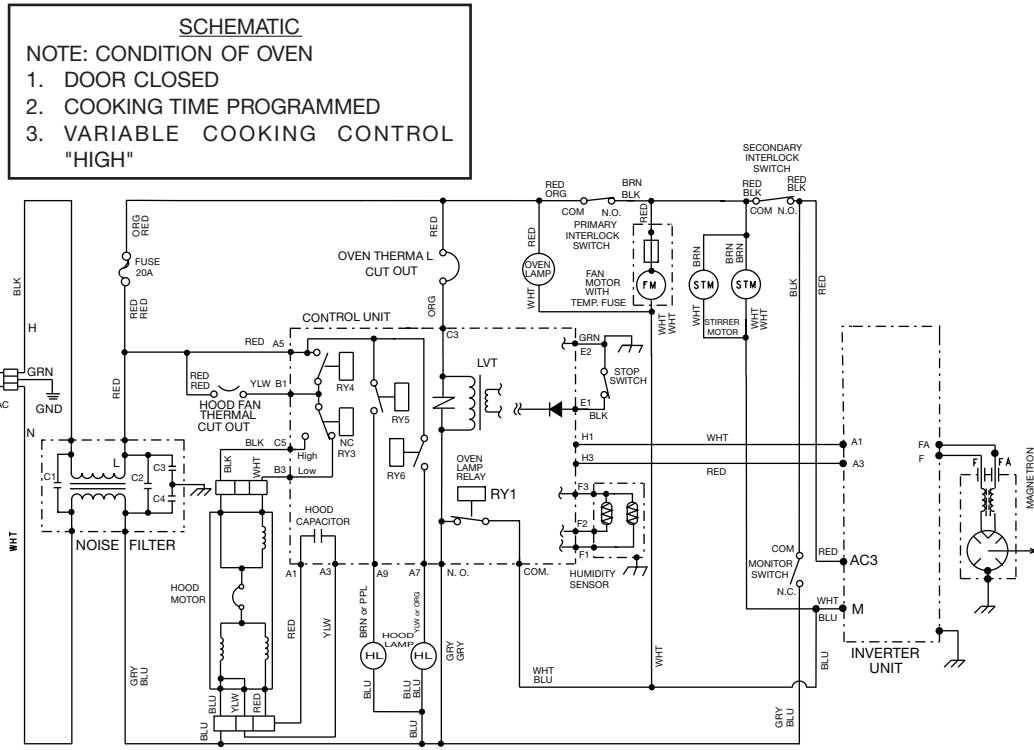

- NOTES:
1. Circuits / Wire Colors subject to change without notice.
 2. Terminal that located to the right side on the lamp socket's back view must be connected to neutral wire.
 3. Only certain models use the absolute humidity sensor

Figure O-2. Oven Schematic-Cooking Condition

Component Descriptions

DOOR OPEN MECHANISM

The door is opened by pushing the open button on the control panel, refer to the Figure D-1. When the open button is pushed, the open button pushes up the open lever, and then the open lever pushes up the latch head. The latch heads are moved upward and released from latch hook. Now the door will open.

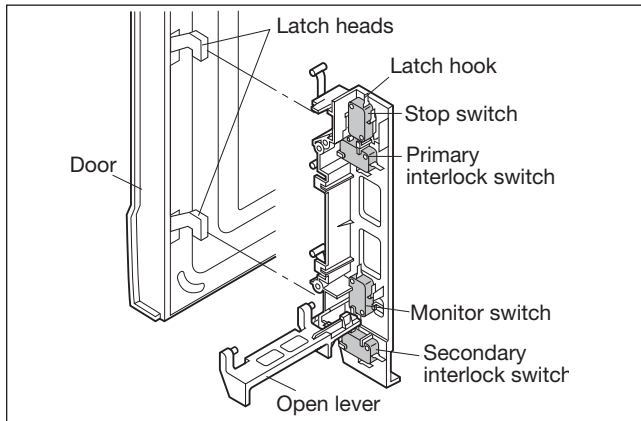

Figure D-1. Door Open Mechanism

STOP, PRIMARY INTERLOCK AND SECONDARY INTERLOCK SWITCHES

The secondary interlock switch is mounted in the lower position of the latch hook and the stop switch is mounted in the upper position of the latch hook. The primary interlock switch is also in the upper position of the latch hook. They are activated by the latch heads on the door. When the door is opened, the switches interrupt the circuit to all components.

A cook cycle cannot take place until the door is firmly closed thereby activating both interlock switches.

MONITOR SWITCH

The monitor switch is activated (the contacts opened) by the latch head on the door while the door is closed. The switch is intended to render the oven inoperative by means of blowing the monitor fuse when the contacts of the primary interlock switch and secondary interlock switch fail to open when the door is opened.

Functions:

1. When the door is opened, the monitor switch contact close (to the ON condition) due to their being normally, closed. At this time the primary interlock switch and secondary interlock switch are in the OFF condition (contacts open) due to

their being normally open contact switches. And the contacts of relay (RY1) are in the ON condition (contacts close).

2. As the door goes to a closed position, the monitor switch contacts are first opened and the stop switch contacts close, and then the primary interlock switch and the secondary interlock switch contacts close. (On opening the door, each of these switches operate inversely.)
3. If the door is opened, and the primary interlock switch and secondary interlock switch contacts fail to open, the monitor fuse blows simultaneously with closing of the monitor switch contacts.

CAUTION: Before replacing a blown monitor fuse, test the stop switch, primary and secondary interlock switch and monitor switch for proper operation.

NOTE: Monitor fuse and switch are replaced as an assembly

THERMAL CUT-OUT (HOOD)

This thermal cut-out located on the right base plate. It is designed to automatically turn on the hood fan motor whenever the hot air rising from the conventional range below causes the temperature at the thermal cut-out to rise to 140F (60C) or higher, thus removing this hot air from around microwave oven. When the temperature around the thermal cut-out drops to 113F (45C) or lower, the thermal cut-out shuts off the hood fan motor.

THERMAL CUT-OUT (OVEN)

This thermal cut-out is located on the top of the oven cavity. It is designed to prevent damage to the oven unit if the food in the oven catches fire due to overheating produced by improper setting of cooking time or failure of control unit. Under normal operation, the thermal cut-out remains closed. However, the thermal cut-out will open at 293F (145C) causing the oven to shut down.

COOLING FAN MOTOR

The cooling fan motor drives a blade which draws external cool air. This cool air is directed through the air vanes surrounding the magnetron and cools the magnetron. This air is channeled through the oven cavity to remove steam and vapors given off from the heating foods. It is then exhausted through the exhausting air vents at the oven cavity.

HOOD FAN MOTOR

The hood fan motor is a two-speed, single-phase, double pole induction type, requiring a hood fan capacitor. It is located outside the upper rear part of the oven cavity, is to remove, from around the oven, hot air rising from the conventional electric or gas range over which it is installed. This air is then expelled either vertically or horizontally through the customer supplied duct system, or discharged back into the kitchen.

STIRRER MOTOR

The stirrer motors drive the stirrer fans to stir the microwave radiation from the waveguide.

HOOD LAMP

The hood lamps are mounted at the hood lamp angle. The hood lamps can be turned off and on by touching the Light Options pad. And also the brightness can be varied to high or low by touching the Light Options pad.

Touch Control Panel Operation

The touch control section consists of the following units as shown in the touch control panel circuit.

- (1) Key Unit
- (2) Control Unit (The Control unit consists of LSI Unit and Power Unit)

The principal functions of these units and the signals communicated among them are explained below.

Key Unit

The key unit is composed of a matrix, signals generated in the LSI are sent to the key unit through P20, P21, P22, P23, P24, P25, P26 and P27. When a key pad is touched, a signal is completed through the key unit and passed back to the LSI through P43, P44, P45 and P46 to perform the function that was requested.

Control Unit

Control unit consists of LSI, power source circuit, synchronizing signal circuit, reset circuit, buzzer circuit, relay circuit indicator circuit, back light circuit and humidity sensor circuit.

- 1) LSI
This LSI controls the key strobe signal, relay driving signal for oven function and indicator signal.
- 2) Power Source Circuit
This circuit generates voltages necessary for the control unit from the AC line voltage. In addition, the synchronizing signal is available in order to compose a basic standard time in the clock circuit.

Symbol	Voltage	Application
VC	-5.0V	LSI(IC1)

- 3) Synchronizing Signal Circuit
The power source synchronizing signal is available in order to compose a basic standard time in the clock circuit. It incorporates a very small error because it works on commercial frequency.
- 4) Reset Circuit
A circuit to generate a signals which resetting the LSI to the initial state when power is applied.
- 5) Buzzer Circuit
The buzzer is responds to signals from the LSI to emit audible sounds (key touch sound and completion sound).
- 6) Stop Switch
A switch to inform the LSI if the door is open or closed.
- 7) Relay Circuit
To drive the inverter unit, fan motor, stirrer motor, hood motor, and light the oven lamp and hood lamp.
- 8) Indicator Circuit
This circuit consists of 25 segments and 4 common electrodes using a Light Crystal Display.
- 9) Back Light Circuit
A circuit to drive the back light (Light emitting diodes LD1-LD5).
- 10) Humidity Sensor Circuit
This circuit detects moisture of the cooking food to allow its automatic cooking.
- 11) Inverter Unit Control Circuit
This is the circuit to control inverter unit.

Description of LSI

LSI

The I/O signal of the LSI is detailed in the following table.

Pin No.	Signal	I/O	Description
1-2	VL2-VL1	IN	<u>Power source voltage input terminal.</u> Standard voltage for LCD.
3-5	AN7-AN5	IN	<u>Terminal to change cooking input according to the Model.</u> By using the A/D converter contained in the LSI, DC voltage in accordance with the Model in operation is applied to set up its cooking constant.
6	AN4	IN	<u>Temperature measurement input: MAGNETRON THERMISTOR.</u> By inputting DC voltage corresponding to the temperature detected by the thermistor, this input is converted into temperature by the A/D converter built into the LSI.
7	AN3	OUT	Back light circuit (Light emitting diodes) driving signal.
8	AN2	IN	<u>To input signal which communicates the door open/close information to LSI.</u> Door close "H" level signal (0V). Door open "L" level signal (-5V).
9	AN1	IN	<u>Humidity sensor input f</u> This input is an analog input terminal from the humidity sensor circuit, and connected to the A/D converter built into the LSI.
10	AN0	IN	Used for initial balancing of the bridge circuit (humidity sensor). This input is an analog input terminal from the humidity sensor circuit, and connected to the A/D converter built into the LSI
11	P57	OUT	<u>Oven lamp, fan motor stirrer motor and inverter unit driving signal</u> To turn on and off shut off relay (RY 1). The square waveform voltage is delivered to the RY 1 driving circuit.
12	P56	OUT	<u>Signal to sound buzzer (2.0 kHz).</u> A: key touch sound. B: Completion sound.
13	P50	OUT	Terminal not used.
14-18	P54-P50	OUT	Used for initial balancing of the bridge circuit (humidity sensor)
19	P47	OUT	<u>Power level data output signal for inverter unit.</u> The power level will be decided by the time ratio of T1 and T2.
20	P46	IN	<u>Signal coming from touch key.</u> When either G1 line on key matrix is touched, a corresponding signal out of P20 - P27 will be input into P46. When no key is touched, the signal is held at "H" level.
21	P45	IN	<u>Signal similar to P46.</u> When either G2 line on key matrix is touched, a corresponding signal will be input into P45.
22	P44	IN	<u>Signal similar to P46.</u> When either G3 line on key matrix is touched, a corresponding signal will be input into P44.
23	P43	IN	<u>Signal similar to P46.</u> When either G4 line on key matrix is touched, a corresponding signal will be input into P43.
24	INT0	IN	<u>Signal synchronized with commercial power source frequency.</u> This is the basic timing for time processing of LSI.

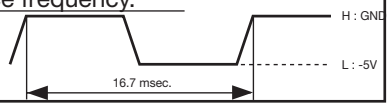
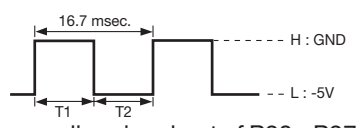
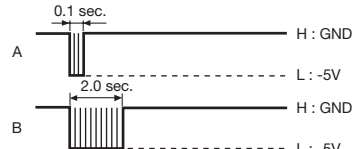
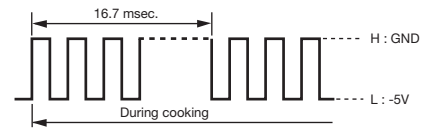

Pin No.	Signal	I/O	Description	
25	P41	OUT	Terminal not used.	
26	P40	IN	Connected to GND through the pull-down resistor.	
27	RESET	IN	<u>Auto clear terminal.</u> Signal is input to reset the LSI to the initial state when power is applied.	
28	P71	OUT	Clock signal is output to a memory IC (IC3).	
29	P70	OUT	Data signal is output to a memory IC (IC3).	
30	XIN	IN	<u>Internal clock oscillation frequency input setting.</u> The internal clock frequency is set by inserting the ceramic filter oscillation circuit with respect to XOUT terminal.	
31	XOUT	OUT	<u>Internal clock oscillation frequency control output.</u> Output to control oscillation input of XIN.	
32	VSS	IN	<u>Power source voltage: -5.0V.</u> VC voltage of power source circuit input.	
33	P27	OUT	<u>Key strobe signal.</u> Signal applied to touch-key section. A pulse signal is input to P43-P46 terminal while one of G5 line keys on key matrix is touched.	
34	P26	OUT	<u>Key strobe signal.</u> Signal applied to touch-key section. A pulse signal is input to P43-P46 terminal while one of G6 line keys on key matrix is touched.	
35	P25	OUT	<u>Key strobe signal.</u> Signal applied to touch-key section. A pulse signal is input to P43-P46 terminal while one of G7 line keys on key matrix is touched.	
36	P24	OUT	<u>Key strobe signal.</u> Signal applied to touch-key section. A pulse signal is input to P43-P46 terminal while one of G8 line keys on key matrix is touched.	
37	P23	OUT	<u>Key strobe signal.</u> Signal applied to touch-key section. A pulse signal is input to P43-P46 terminal while one of G9 line keys on key matrix is touched.	
38	P22	OUT	<u>Key strobe signal.</u> Signal applied to touch-key section. A pulse signal is input to P43-P46 terminal while one of G10 line keys on key matrix is touched.	
39	P21	OUT	<u>Key strobe signal.</u> Signal applied to touch-key section. A pulse signal is input to P43-P46 terminal while one of G11 line keys on key matrix is touched.	
40	P20	OUT	<u>Key strobe signal.</u> Signal applied to touch-key section. A pulse signal is input to P43-P46 terminal while one of G12 line keys on key matrix is touched.	
41	P17	OUT	<u>Hood lamp driving signal.</u> To turn on and off relay(RY6). "L" level: During Hood lamp ON. "H" level: During Hood lamp OFF.	
42	P16	OUT	<u>Hood lamp driving signal.</u> To turn on and off relay(RY5). "L" level: During Hood lamp ON. "H" level: During Hood lamp OFF.	
	43	P15	OUT <u>Hood motor high / low driving signal.</u> To turn on and off relay(RY3). "L" level: During Hood motor high. "H" level: During Hood motor low.	
	44	P14	OUT <u>Hood motor driving signal.</u> To turn on and off relay(RY4). "L" level: During Hood motor on. "H" level: During Hood motor OFF.	
45-46	P13-P12	OUT	Terminal not used.	

Pin No.	Signal	I/O	Description																																																								
47	SEG25	OUT	Terminal not used.																																																								
48-72	SEG24-SEG0	OUT	<p>Segment data signal. Connected to LCD.</p> <p>The relation between signals are as follows:</p> <table border="0"> <thead> <tr> <th>LSI signal (Pin No.)</th> <th>LCD (Pin No.)</th> <th>LSI signal (Pin No.)</th> <th>LCD (Pin No.)</th> </tr> </thead> <tbody> <tr> <td>SEG 24 (48)-----</td> <td>SEG 24 (29)</td> <td>SEG 11 (61)-----</td> <td>SEG 11 (16)</td> </tr> <tr> <td>SEG 23 (49)-----</td> <td>SEG 23 (28)</td> <td>SEG 10 (62)-----</td> <td>SEG 10 (15)</td> </tr> <tr> <td>SEG 22 (50)-----</td> <td>SEG 22 (27)</td> <td>SEG 9 (63)-----</td> <td>SEG 9 (14)</td> </tr> <tr> <td>SEG 21 (51)-----</td> <td>SEG 21 (26)</td> <td>SEG 8 (64)-----</td> <td>SEG 8 (13)</td> </tr> <tr> <td>SEG 20 (52)-----</td> <td>SEG 20 (25)</td> <td>SEG 7 (65)-----</td> <td>SEG 7 (12)</td> </tr> <tr> <td>SEG 19 (53)-----</td> <td>SEG 19 (24)</td> <td>SEG 6 (66)-----</td> <td>SEG 6 (11)</td> </tr> <tr> <td>SEG 18 (54)-----</td> <td>SEG 18 (23)</td> <td>SEG 5 (67)-----</td> <td>SEG 5 (10)</td> </tr> <tr> <td>SEG 17 (55)-----</td> <td>SEG 17 (22)</td> <td>SEG 4 (68)-----</td> <td>SEG 4 (9)</td> </tr> <tr> <td>SEG 16 (56)-----</td> <td>SEG 16 (21)</td> <td>SEG 3 (69)-----</td> <td>SEG 3 (8)</td> </tr> <tr> <td>SEG 15 (57)-----</td> <td>SEG 15 (20)</td> <td>SEG 2 (70)-----</td> <td>SEG 2 (7)</td> </tr> <tr> <td>SEG 14 (58)-----</td> <td>SEG 14 (19)</td> <td>SEG 1 (71)-----</td> <td>SEG 1 (6)</td> </tr> <tr> <td>SEG 13 (59)-----</td> <td>SEG 13 (18)</td> <td>SEG 0 (72)-----</td> <td>SEG 0 (5)</td> </tr> <tr> <td>SEG 12 (60)-----</td> <td>SEG 12 (17)</td> <td></td> <td></td> </tr> </tbody> </table>	LSI signal (Pin No.)	LCD (Pin No.)	LSI signal (Pin No.)	LCD (Pin No.)	SEG 24 (48)-----	SEG 24 (29)	SEG 11 (61)-----	SEG 11 (16)	SEG 23 (49)-----	SEG 23 (28)	SEG 10 (62)-----	SEG 10 (15)	SEG 22 (50)-----	SEG 22 (27)	SEG 9 (63)-----	SEG 9 (14)	SEG 21 (51)-----	SEG 21 (26)	SEG 8 (64)-----	SEG 8 (13)	SEG 20 (52)-----	SEG 20 (25)	SEG 7 (65)-----	SEG 7 (12)	SEG 19 (53)-----	SEG 19 (24)	SEG 6 (66)-----	SEG 6 (11)	SEG 18 (54)-----	SEG 18 (23)	SEG 5 (67)-----	SEG 5 (10)	SEG 17 (55)-----	SEG 17 (22)	SEG 4 (68)-----	SEG 4 (9)	SEG 16 (56)-----	SEG 16 (21)	SEG 3 (69)-----	SEG 3 (8)	SEG 15 (57)-----	SEG 15 (20)	SEG 2 (70)-----	SEG 2 (7)	SEG 14 (58)-----	SEG 14 (19)	SEG 1 (71)-----	SEG 1 (6)	SEG 13 (59)-----	SEG 13 (18)	SEG 0 (72)-----	SEG 0 (5)	SEG 12 (60)-----	SEG 12 (17)		
LSI signal (Pin No.)	LCD (Pin No.)	LSI signal (Pin No.)	LCD (Pin No.)																																																								
SEG 24 (48)-----	SEG 24 (29)	SEG 11 (61)-----	SEG 11 (16)																																																								
SEG 23 (49)-----	SEG 23 (28)	SEG 10 (62)-----	SEG 10 (15)																																																								
SEG 22 (50)-----	SEG 22 (27)	SEG 9 (63)-----	SEG 9 (14)																																																								
SEG 21 (51)-----	SEG 21 (26)	SEG 8 (64)-----	SEG 8 (13)																																																								
SEG 20 (52)-----	SEG 20 (25)	SEG 7 (65)-----	SEG 7 (12)																																																								
SEG 19 (53)-----	SEG 19 (24)	SEG 6 (66)-----	SEG 6 (11)																																																								
SEG 18 (54)-----	SEG 18 (23)	SEG 5 (67)-----	SEG 5 (10)																																																								
SEG 17 (55)-----	SEG 17 (22)	SEG 4 (68)-----	SEG 4 (9)																																																								
SEG 16 (56)-----	SEG 16 (21)	SEG 3 (69)-----	SEG 3 (8)																																																								
SEG 15 (57)-----	SEG 15 (20)	SEG 2 (70)-----	SEG 2 (7)																																																								
SEG 14 (58)-----	SEG 14 (19)	SEG 1 (71)-----	SEG 1 (6)																																																								
SEG 13 (59)-----	SEG 13 (18)	SEG 0 (72)-----	SEG 0 (5)																																																								
SEG 12 (60)-----	SEG 12 (17)																																																										
73/74	VCC/VREF	IN	Connected to GND.																																																								
75	AVSS	IN	Connected to VC.																																																								
76	COM3	OUT	Common data signal. Connected to LCD signal COM4.																																																								
77	COM2	OUT	Common data signal. Connected to LCD signal COM3.																																																								
78	COM1	OUT	Common data signal. Connected to LCD signal COM2.																																																								
79	COM0	OUT	Common data signal. Connected to LCD signal COM1.																																																								
80	VL3	IN	Power source voltage input terminal.																																																								

Humidity Sensor Circuit

(1) Structure of Humidity Sensor

The humidity sensor includes two thermistors as shown in the illustration. One thermistor is housed in the closed vessel filled with dry air while another in the open vessel. Each sensor is provided with the protective cover made of metal mesh to be protected from the external airflow.

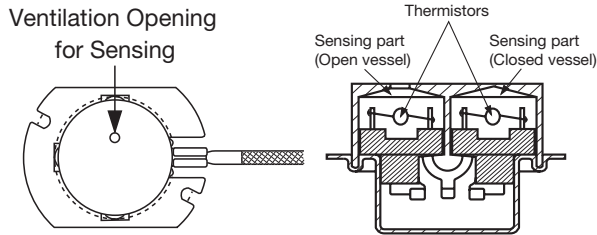

(2) Operational Principle of Humidity Sensor

The figure below shows the basic structure of a humidity sensor. A bridge circuit is formed by two thermistors and two resistors (R1 and R2). The output of the bridge circuit is to be amplified by the operational amplifier.

Each thermistor is supplied with a current to keep it heated at about 150C (302F), the resultant heat is dissipated in the air and if the two thermistors are placed in different humidity conditions they show different degrees of heat conductivity leading to a potential difference between them causing an output voltage from the bridge circuit, the intensity of which is increased as the absolute humidity of the air increases. Since the output is very minute, it is amplified by the operational amplifier.

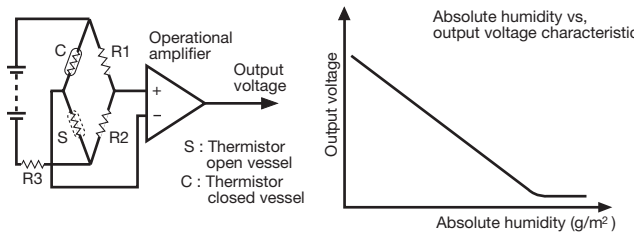

(3) Detector Circuit of Humidity Sensor Circuit

This detector circuit is used to detect the output voltage of the humidity circuit to allow the LSI to control sensor cooking of the unit. When the unit is set in the sensor cooking mode, 16 seconds clearing cycle occurs than the detector circuit starts to function and the LSI observes the initial voltage available at its AN1 terminal. With this voltage given, the switches SW1 to SW5 in the LSI are turned on in such a way as to change the resistance values in parallel with R98 ~ R102. Changing the resistance values results in that there is the same potential at both F-3 terminal of the humidity sensor and AN0 terminal of the LSI. The voltage of AN1 terminal will indicate about 2.5V. This initial balancing is set up about 16 seconds after the unit is put in the Sensor Cooking mode.

As the sensor cooking proceeds, the food is heated to generate moisture by which the resistance balance of the bridge circuit is deviated to increase the voltage available at AN1 terminal of the LSI. Then the LSI observes that voltage at AN1 terminal and compares it with its initial value, and when the comparison rate reaches the preset value (fixed for each menu to be cooked), the LSI causes the unit to stop sensor cooking; thereafter, the unit goes in the next operation automatically. When the LSI starts to detect the initial voltage at AN1 terminal 16 seconds after the unit has been put in the Sensor Cooking mode, if it is not possible to balance the bridge circuit due to disconnection of the humidity sensor, ERROR will appear on the display and cooking is stopped.

1) Humidity sensor circuit

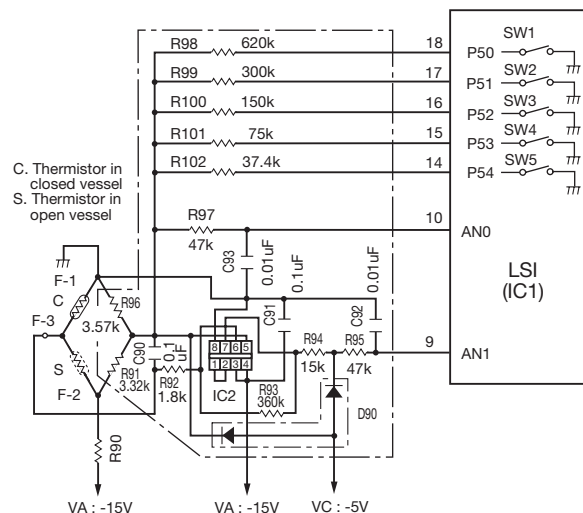

Section 3

Troubleshooting Guide

Troubleshooting Guide

When troubleshooting the microwave oven, it is helpful to follow the Sequence of Operation in performing the checks. Many of the possible causes of trouble will require that a specific test be performed. These tests are given a procedure letter which will be found in the "Test Procedure" section.

IMPORTANT: If the oven becomes inoperative because of a blown monitor fuse, check the monitor switch, relay (RY1) primary interlock switch and secondary interlock switch before replacing the monitor fuse. If monitor fuse is replaced, the monitor switch must also be replaced. Use part FFS-BA016/KIT as an assembly.

IMPORTANT: Whenever troubleshooting is performed with the power supply cord disconnected. It may in some cases, be necessary to connect the power supply cord after the outer case has been removed, in this event:

1. Disconnect the power supply cord, and then remove outer case.
2. Open the door and block it open.
3. Disconnect the leads to the primary of the inverter unit.
4. Ensure that the leads remain isolated from other components and oven chassis by using insulation tape.
5. After that procedure, reconnect the power supply cord.

When the testing is completed:

1. Disconnect the power supply cord, and then remove outer case.
2. Open the door and block it open.
3. Reconnect all leads removed from components during testing.
4. Reinstall the outer case (cabinet).
5. Reconnect the power supply cord after the outer case is installed.
6. Run the oven and check all functions.

Test Procedures

Procedure Letter	Component Test
<p style="text-align: center;">A</p>	<p>MAGNETRON ASSEMBLY TEST</p> <ol style="list-style-type: none"> 1. Disconnect the power supply cord, and then remove outer case. 2. Open the door and block it open. 3. To test for an open filament, isolate the magnetron from the high voltage circuit. A continuity check across the magnetron filament leads should indicate less than 1 ohm. 4. To test for a shorted magnetron, connect the ohmmeter leads between the magnetron filament leads and chassis ground. This test should indicate an infinite resistance. If there is little or no resistance the magnetron is grounded and must be replaced. 5. Reconnect all leads removed from components during testing. 6. Reinstall the outer case (cabinet). 7. Reconnect the power supply cord after the outer case is installed. 8. Run the oven and check all functions. <p>MICROWAVE OUTPUT POWER</p> <p>The following test procedure should be carried out with the microwave oven in a fully assembled condition (outer case fitted).</p> <p>HIGH VOLTAGES ARE PRESENT DURING THE COOK CYCLE, SO EXTREME CAUTION SHOULD BE OBSERVED.</p> <p>Power output of the magnetron can be measured by performing a water temperature rise test. This test should only be used if above tests do not indicate a faulty magnetron and there is no defect in the following components or wiring: inverter unit. This test will require a 16 ounce (453cc) measuring cup and an accurate mercury thermometer or thermocouple type temperature tester. For accurate results, the following procedure must be followed carefully:</p> <ol style="list-style-type: none"> 1. Fill the measuring cup with 1 6 oz. (453cc) of tap water and measure the temperature of the water with a thermometer or thermocouple temperature tester. Stir the thermometer or thermocouple through the water until the temperature stabilizes. Record the temperature of the water. 2. Place the cup of water in the oven. Operate oven at POWER 10(HIGH) selecting more than 60 seconds cook time. Allow the water to heat for 60 seconds, measuring with a stop watch, second hand of a watch or the digital read-out countdown. 3. Remove cup from oven and again measure the temperature, making sure to stir the thermometer or thermocouple through the water until the maximum temperature is recorded. 4. Subtract the cold water temperature from the hot water temperature. The normal result should be 39.2 to 63F(21.8 to 35C) rise in temperature. If the water temperatures are accurately measured and tested for the required time period the test results will indicate if the magnetron tube has low power output (low rise in water temperature) which would extend cooking time or high power output (high rise in water temperature) which would reduce cooking time. Because cooking time can be adjusted to compensate for power output, the magnetron tube assembly should be replaced only if the water temperature rise test indicates a power output well beyond the normal limits. The test is only accurate if the power supply line voltage is 120 volts and the oven cavity is clean.

Procedure Letter	Component Test
<p>B</p>	<p>INVERTER UNIT TEST</p> <p>WARNING: DO NOT TOUCH THE COMPONENTS OF THE INVERTER UNIT WHILE INVERTER UNIT IS ENERGIZED. IT IS DANGEROUS BECAUSE THIS HAS HIGH VOLTAGE COMPONENTS.</p> <p>CAUTION: Do not operate inverter unit by itself . CAUTION: Do not connect the oven to wall outlet without the outer case installed.</p> <p>Before checking the inverter unit, carry out the following 4 steps.</p> <ol style="list-style-type: none"> 1. Disconnect the power supply cord, and then remove outer case. 2. Open the door and block it open. 3. Make sure that the wire leads and the connectors are connected correctly to the inverter unit, control unit and magnetron. <p>Chart for checking the defective inverter unit:</p> <pre> graph TD A[No power at full power output cooking] --> B[Magnetron is defective.] B -- YES --> C[Exchange the magnetron.] B -- NO --> D[Exchange the Inverter unit] E[Blown monitor fuse] --> F[The secondary interlock switch, primary interlock switch and the monitor switch are operating properly.] F -- NO --> G[Check the switches according to the switch Test Procedure] F -- YES --> H[Exchange the Inverter unit] </pre>
<p>C</p>	<p>OVEN THERMAL CUT-OUT TEST</p> <ol style="list-style-type: none"> 1. Disconnect the power supply cord, and then remove outer case. 2. Open the door and block it open. 3. A continuity check across the thermal cut-out terminals should indicate a closed circuit unless the temperature of the thermal cut-out reaches approximately 293F(145C). An open thermal cut-out indicates overheating of the oven, exchange the oven thermal cut-out and check inside of oven cavity and for improper setting of cooking time or operation of control unit. Check for restricted air flow through the vent holes of the oven cavity, especially the cooling fan and air guide. 4. Reconnect all leads removed from components during testing. 5. Reinstall the outer case (cabinet). 6. Reconnect the power supply cord after the outer case is installed. 7. Run the oven and check all functions. <p>CAUTION: IF THE THERMAL CUT-OUT INDICATES AN OPEN CIRCUIT AT ROOM TEMPERATURE, REPLACE THERMAL CUT-OUT.</p>

Procedure Letter	Component Test
<p>D</p>	<p>PRIMARY INTERLOCK SWITCH AND SECONDARY INTERLOCK SWITCH TEST</p> <ol style="list-style-type: none"> 1. Disconnect the power supply cord, and then remove outer case. 2. Open the door and block it open. 3. Isolate the switch and connect the ohmmeter to the common (COM.) and normally open (NO) terminal of the switch. The meter should indicate an open circuit with the door open and a closed circuit with the door closed. If improper operation is indicated, replace the primary interlock switch or secondary interlock switch. 4. Reconnect all leads removed from components during testing. 5. Reinstall the outer case (cabinet). 6. Reconnect the power supply cord after the outer case is installed. 7. Run the oven and check all functions.
<p>E</p>	<p>STOP SWITCH TEST</p> <ol style="list-style-type: none"> 1. Disconnect the power supply cord, and then remove outer case. 2. Open the door and block it open. 3. Isolate switch and connect the ohmmeter to the common (COM.) and normally open (NO) terminal of the switch. The meter should indicate an open circuit with door open and a closed circuit with door closed. If improper operation is indicated, replace the stop switch. 4. Reconnect all leads removed from components during testing. 5. Reinstall the outer case (cabinet). 6. Reconnect the power supply cord after the outer case is installed. 7. Run the oven and check all functions. <p>NOTE: If the stop switch contacts fail in the open position and the door is closed, the cooling fan motor, stirrer motor and oven light will be activated by RY1.</p>
<p>F</p>	<p>MONITOR SWITCH TEST</p> <ol style="list-style-type: none"> 1. Disconnect the power supply cord, and then remove outer case. 2. Open the door and block it open. 3. Before performing this test, make sure that the secondary interlock switch and the primary interlock switch are operating properly, according to the above Switch Test Procedure. Disconnect the wire lead from the monitor switch (COM) terminal. Check the monitor switch operation by using the ohmmeter as follows. When the door is open, the meter should indicate a closed circuit. When the monitor switch actuator is pushed by a screw driver through the lower latch hole on the front plate of the oven cavity with the door opened (in this condition the plunger of the monitor switch is pushed in), the meter should indicate an open circuit. If improper operation is indicated, the switch may be defective. After testing the monitor switch, reconnect the wire lead to the monitor switch (COM) terminal and check the continuity of the monitor circuit. 4. Reconnect all leads removed from components during testing. 5. Reinstall the outer case (cabinet). 6. Reconnect the power supply cord after the outer case is installed. 7. Run the oven and check all functions.

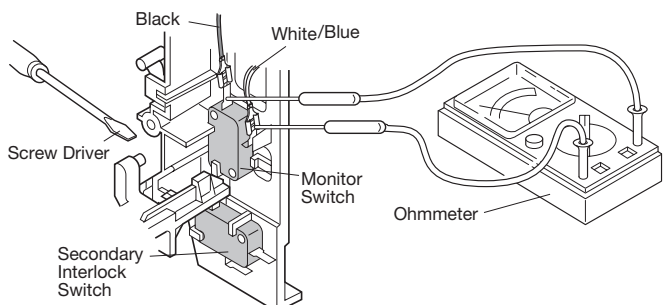

Procedure Letter	Component Test
<p>G</p>	<p>BLOWN MONITOR FUSE TEST</p> <ol style="list-style-type: none"> 1. Disconnect the power supply cord, and then remove outer case. 2. Open the door and block it open. 3. If the monitor fuse is blown when the door is opened, check the primary interlock switch, secondary interlock switch and monitor switch according to the "TEST PROCEDURE" for those switches before replacing the blown monitor fuse. <p>CAUTION: BEFORE REPLACING A BLOWN MONITOR FUSE, TEST THE PRIMARY INTERLOCK SWITCH, SECONDARY INTERLOCK SWITCH AND MONITOR SWITCH FOR PROPER OPERATION.</p> <p>If the monitor fuse is blown by improper switch operation, the monitor fuse and monitor switch must be replaced with "monitor fuse and monitor switch assembly" part number FFS-BA016/KIT, even if the monitor switch operates normally. The monitor fuse and monitor switch assembly is comprised of a 20 ampere fuse and switch.</p> <ol style="list-style-type: none"> 5. Reconnect all leads removed from components during testing. 6. Reinstall the outer case (cabinet). 7. Reconnect the power supply cord after the outer case is installed. 8. Run the oven and check all functions.
<p>H</p>	<p>HOOD THERMAL CUT-OUT TEST</p> <ol style="list-style-type: none"> 1. Disconnect the power supply cord, and then remove outer case. 2. Open the door and block it open. 3. A continuity check across the thermal cut-out terminals should indicate an open circuit unless the temperature of the thermal cut-out reaches approximately 140 F(60 C) or more. At that temperature, the contacts will close. The thermal cut-out opens automatically at approximately 113 F(45 C). 4. Reconnect all leads removed from components during testing. 5. Reinstall the outer case (cabinet). 6. Reconnect the power supply cord after the outer case is installed. 7. Run the oven and check all functions.

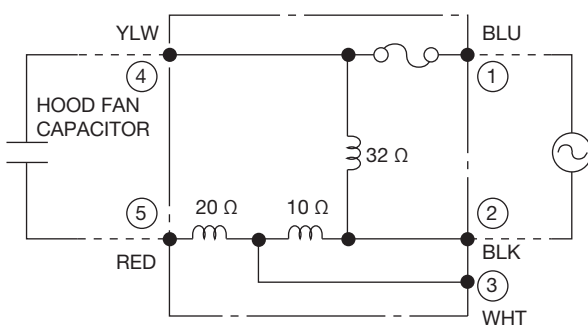
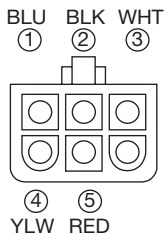
Procedure Letter	Component Test
<p>I</p>	<p>HOOD FAN MOTOR TEST</p> <ol style="list-style-type: none"> 1. Disconnect the power supply cord, and then remove outer case. 2. Open the door and block it open. 3. If the motor does not turn, touch the FAN HI/LO pad once (set hood fan motor power "HIGH") and check voltage between pins "1" and "2" (Blue and Black wires) of the 6 pin connector. If 1 20 Volts appear and the hood capacitor is good, replace the hood fan assembly. If 1 20 Volts does not appear, check the motor circuit. The resistance values of motor terminals are as follows in the chart below: 4. Reconnect all leads removed from components during testing. 5. Reinstall the outer case (cabinet). 6. Reconnect the power supply cord after the outer case is installed. 7. Run the oven and check all functions. <div style="text-align: right; margin-right: 100px;"> <p>Resistance between;</p> <p>BLU (1) AND YLW (4) = 0 Ω (Shorted)</p> <p>BLK (2) AND YLW (4) = 32 Ω</p> <p>BLU (1) AND BLK (2) = 32 Ω</p> <p>BLK (2) AND WHT (3) = 10 Ω</p> <p>WHT (3) AND RED (5) = 20 Ω</p> </div>  <div style="text-align: right; margin-right: 100px;">  <p>6-PIN CONNECTOR OF HOOD FAN MOTOR</p> </div>
<p>J</p>	<p>TOUCH CONTROL PANEL ASSEMBLY TEST</p> <p>The touch control panel consists of circuits including semiconductors such as LSI, ICs, etc. Therefore, unlike conventional microwave ovens, proper maintenance cannot be performed with only a voltmeter and ohmmeter. In this service manual, the touch control panel assembly is divided into two units, Control Unit and Key Unit, and also the Control Unit is divided into two units, LSI Unit and Power Unit, and troubleshooting by unit replacement is described according to the symptoms indicated.</p> <p>Before testing,</p> <ol style="list-style-type: none"> 1. Disconnect the power supply cord, and then remove outer case. Refer to procedure of "HOOD LOUVER REMOVAL", "REMOVAL OF OVEN FROM WALL " and " OUTER CASE REMOVAL". 2. Open the door and block it open. 3. Remove seven (7) screws holding the hood intake duct R to the oven cavity top plate, oven cavity flange, fun duct, magnetron duct and the base plate R. Remove the hood intake duct R. 4. Disconnect the leads to the primary of the inverter unit. 5. Ensure that these leads remain isolated from other components and oven chassis by using insulation tape.

Procedure Letter	Component Test
J	<p>1. Key Unit.</p> <p>NOTE:</p> <ol style="list-style-type: none"> 1. Check key unit ribbon connection before replacement. 2. Re-install the hood intake duct R with seven (7) screws. 3. Re-install the outer case (cabinet). 4. Reconnect the power supply cord after the outer case is installed. 5. Run the oven and check all functions. <p>The following symptoms indicate a defective key unit.</p> <ol style="list-style-type: none"> a) When touching the pads, a certain pad produces no signal at all. b) When touching a number pad, two figures or more are displayed. c) When touching the pads, sometimes a pad produces no signal. <p>If the key unit is defective.</p> <ol style="list-style-type: none"> 1. Disconnect the power supply cord, and then remove outer case. 2. Open the door and block it open. 3. Replace the key unit. 4. Reconnect all leads removed from components during testing. 5. Re-install the outer case (cabinet). 6. Reconnect the power supply cord after the outer case is installed. 7. Run the oven and check all functions. <p>2. Control Unit.</p> <p>The following symptoms indicate a defective control unit. Before replacing the control unit, perform the Key unit test (Procedure K) to determine if control unit is faulty.</p> <p>2-1 In connection with pads.</p> <ol style="list-style-type: none"> a) When touching the pads, a certain group of pads do not produce a signal. b) When touching the pads, no pads produce a signal. <p>2-2 In connection with indicators</p> <ol style="list-style-type: none"> a) At a certain digit, all or some segments do not light up. b) At a certain digit, brightness is low. c) Only one indicator does not light. d) The corresponding segments of all digits do not light up; or they continue to light up. e) Wrong figure appears. f) A certain group of indicators do not light up. g) The figure of all digits flicker. <p>2-3 Other possible problems caused by defective control unit.</p> <ol style="list-style-type: none"> a) Buzzer does not sound or continues to sound. b) Clock does not operate properly. c) Cooking is not possible. <p>When testing is completed,</p> <ol style="list-style-type: none"> 1. Disconnect the power supply cord. 2. Open the door and block it open. 3. Reconnect all leads removed from components during testing. 4. Re-install the hood intake duct R. 5. Re-install the outer case (cabinet). 6. Reconnect the power supply cord after the outer case is installed. 7. Run the oven and check all functions.

Procedure Letter	Component Test
<p>K</p>	<p>KEY UNIT TEST</p> <ol style="list-style-type: none"> 1. Disconnect the power supply cord. 2. Open the door and block it open. 3. Remove the control panel assembly. 4. If the display fails to clear when the STOP/CLEAR pad is depressed, first verify the flat ribbon cable is making good contact, verify that the stop switch operates properly; that is the contacts are closed when the door is closed and open when the door is open. If the stop switch is good, disconnect the flat ribbon cable that connects the key unit to the control unit and make sure the stop switch is closed (either close the door or short the stop switch connector). Use the Key unit matrix indicated on the control panel schematic and place a jumper wire between the pins that correspond to the STOP/CLEAR pad making momentary contact. If the control unit responds by clearing with a beep the key unit is faulty and must be replaced. If the control unit does not respond, it is faulty and must be replaced. If a specific pad does not respond, the above method may be used (after clearing the control unit) to determine if the control unit or key pad is at fault. 5. Reconnect all leads removed from components during testing. 6. Re-install the control panel assembly. 7. Reconnect the power supply cord. 8. Run the oven and check all functions. <div style="text-align: center;"> </div>
<p>L</p>	<p>RELAY TEST</p> <ol style="list-style-type: none"> 1. Disconnect the power supply cord, and then remove outer case. Refer to procedure of “HOOD LOUVER REMOVAL”, “REMOVAL OF OVEN FROM WALL ” and “ OUTER CASE REMOVAL”. 2. Open the door and block it open. 3. Remove the hood intake duct R. 4. Disconnect the leads to the primary of the inverter unit. 5. Ensure that these leads remain isolated from other components and oven chassis by using insulation tape. 6. After that procedure, re-connect the power supply cord.

Procedure Letter	Component Test																		
<p>L</p>	<p>8. Check voltage between the Pin No. 3 of the 3 pin connector (C) and the normal open terminal of the relay RY1 on the control unit with an A.C. voltmeter. The meter should indicate 120 volts, if not check oven circuit. RY1, RY3, RY4, RY5 and RY6 Relay Test: These relays are operated by D.C. voltage Check voltage at the relay coil with a D.C. voltmeter during the microwave cooking operation. DC. voltage indicated.....Defective relay. DC. voltage not indicatedCheck diode which is connected to the relay coil. If diode is good, control unit is defective.</p> <table border="1" data-bbox="354 615 1425 814"> <thead> <tr> <th>RELAY SYMBOL</th> <th>OPERATIONAL VOLTAGE</th> <th>CONNECTED COMPONENTS</th> </tr> </thead> <tbody> <tr> <td>RY1</td> <td>Approx. 25.0V D.C.</td> <td>Inverter unit/ Oven lamp/ Fan motor/Stirrer motor</td> </tr> <tr> <td>RY3</td> <td>Approx. 25.0V D.C.</td> <td>Hood motor (High/ Low selection)</td> </tr> <tr> <td>RY4</td> <td>Approx. 25.0V D.C.</td> <td>Hood motor</td> </tr> <tr> <td>RY5</td> <td>Approx. 25.0V D.C.</td> <td>Hood lamp</td> </tr> <tr> <td>RY6</td> <td>Approx. 25.0V D.C.</td> <td>Hood lamp</td> </tr> </tbody> </table> <p>9. Disconnect the power supply cord. 10. Open the door and block it open. 11. Reconnect all leads removed from components during testing. 12. Re-install the hood intake duct R. 13. Re-install the outer case (cabinet). 14. Reconnect the power supply cord after the outer case is installed.</p>	RELAY SYMBOL	OPERATIONAL VOLTAGE	CONNECTED COMPONENTS	RY1	Approx. 25.0V D.C.	Inverter unit/ Oven lamp/ Fan motor/Stirrer motor	RY3	Approx. 25.0V D.C.	Hood motor (High/ Low selection)	RY4	Approx. 25.0V D.C.	Hood motor	RY5	Approx. 25.0V D.C.	Hood lamp	RY6	Approx. 25.0V D.C.	Hood lamp
RELAY SYMBOL	OPERATIONAL VOLTAGE	CONNECTED COMPONENTS																	
RY1	Approx. 25.0V D.C.	Inverter unit/ Oven lamp/ Fan motor/Stirrer motor																	
RY3	Approx. 25.0V D.C.	Hood motor (High/ Low selection)																	
RY4	Approx. 25.0V D.C.	Hood motor																	
RY5	Approx. 25.0V D.C.	Hood lamp																	
RY6	Approx. 25.0V D.C.	Hood lamp																	
<p>M</p>	<p>DEFROST TEST</p> <p>1. Open the door. 2. Place one cup of water in the center of the turntable tray in the oven cavity. 3. Touch the "DEFROST" pad once. And then touch the number pad " 2 ". 4. Touch the number pad " 5 ". 5. Close the door. 6. Touch the " START " button. 7. The oven is in Easy defrost cooking condition. 8. The oven will operate as follows.</p> <table border="1" data-bbox="354 1459 982 1577"> <thead> <tr> <th rowspan="2">Menu</th> <th colspan="2">1ST STAGE</th> <th colspan="2">2ND STAGE</th> </tr> <tr> <th>LEVEL</th> <th>TIME</th> <th>LEVEL</th> <th>TIME</th> </tr> </thead> <tbody> <tr> <td>0.5lbs</td> <td>40%</td> <td>57sec.</td> <td>40%</td> <td>22sec.</td> </tr> </tbody> </table> <p>9. If improper operation is indicated, the control unit is probably defective and should be checked.</p>	Menu	1ST STAGE		2ND STAGE		LEVEL	TIME	LEVEL	TIME	0.5lbs	40%	57sec.	40%	22sec.				
Menu	1ST STAGE		2ND STAGE																
	LEVEL	TIME	LEVEL	TIME															
0.5lbs	40%	57sec.	40%	22sec.															

Procedure Letter	Component Test																			
N	<p>FOIL PATTERN ON THE PRINTED WIRING BOARD TEST</p> <p>To protect the electronic circuits, this model is provided with a fine foil pattern added to the primary on the PWB, this foil pattern acts as a fuse.</p> <p>1. Foil pattern check and repairs.</p> <ol style="list-style-type: none"> 1) Disconnect the power supply cord. 2) Open the door and block it open. 3) Remove the control unit, referring to the procedure of “ CONTROL PANEL ASSEMBLY, CONTROL UNIT AND KEY UNIT REMOVAL ”. 4) Follow the troubleshooting guide given below for repair. <table border="1" data-bbox="365 625 1474 730"> <thead> <tr> <th>STEPS</th> <th>OCCURRENCE</th> <th>CAUSE OR CORRECTION</th> </tr> </thead> <tbody> <tr> <td>1</td> <td>Only pattern at “a” is broken.</td> <td>*Insert jumper wire J1 and solder.</td> </tr> <tr> <td>2</td> <td>Pattern at “a” and “b” are broken.</td> <td>*Insert the coil RCILF2003YAZZ between “c” and “d”.</td> </tr> </tbody> </table> <p>5) Make a visual inspection of the varistor. Check for burned damage and examine the transformer with a tester for the presence of layer short circuit (check the primary coil resistance which is approximately $160\Omega \pm 10\%$). If any abnormal condition is detected, replace the control unit.</p> <p>6) Reconnect all leads removed from components during testing.</p> <p>7) Re-install the control unit to the control panel and re-install the control panel to the oven.</p> <p>8) Reconnect the power supply cord.</p> <p>9) Run the oven and check all functions.</p> <p>2. Follow the troubleshooting guide given below, if indicator does not light up after above check and repairs are finished.</p> <ol style="list-style-type: none"> 1) Disconnect the power supply cord, and then remove outer case. Refer to procedure of “HOOD LOUVER REMOVAL”, “REMOVAL OF OVEN FROM wall ” and “OUTER CASE REMOVAL”. 2) Open the door and block it open. 3) Remove the hood intake duct R. 4) Disconnect the leads to the primary of the inverter unit. 5) Ensure that these leads remain isolated from other components and oven chassis by using insulation tape. 6) After that procedure, re-connect the power supply cord. 7) Follow the troubleshooting guide given below for repair. <table border="1" data-bbox="357 1732 1466 1921"> <thead> <tr> <th>STEPS</th> <th>OCCURRENCE</th> <th>CAUSE OR CORRECTION</th> </tr> </thead> <tbody> <tr> <td>1</td> <td>The rated AC voltage is not present between the Pin No. 3 of the 3 pin connector (C) and the normal open terminal of the relay RY1.</td> <td>Check supply voltage and oven power cord.</td> </tr> <tr> <td>2</td> <td>The rated AC voltage is present at primary side of low voltage transformer.</td> <td>Low voltage transformer or secondary circuit defective. Check and replace the control unit.</td> </tr> </tbody> </table>		STEPS	OCCURRENCE	CAUSE OR CORRECTION	1	Only pattern at “a” is broken.	*Insert jumper wire J1 and solder.	2	Pattern at “a” and “b” are broken.	*Insert the coil RCILF2003YAZZ between “c” and “d”.	STEPS	OCCURRENCE	CAUSE OR CORRECTION	1	The rated AC voltage is not present between the Pin No. 3 of the 3 pin connector (C) and the normal open terminal of the relay RY1.	Check supply voltage and oven power cord.	2	The rated AC voltage is present at primary side of low voltage transformer.	Low voltage transformer or secondary circuit defective. Check and replace the control unit.
STEPS	OCCURRENCE	CAUSE OR CORRECTION																		
1	Only pattern at “a” is broken.	*Insert jumper wire J1 and solder.																		
2	Pattern at “a” and “b” are broken.	*Insert the coil RCILF2003YAZZ between “c” and “d”.																		
STEPS	OCCURRENCE	CAUSE OR CORRECTION																		
1	The rated AC voltage is not present between the Pin No. 3 of the 3 pin connector (C) and the normal open terminal of the relay RY1.	Check supply voltage and oven power cord.																		
2	The rated AC voltage is present at primary side of low voltage transformer.	Low voltage transformer or secondary circuit defective. Check and replace the control unit.																		

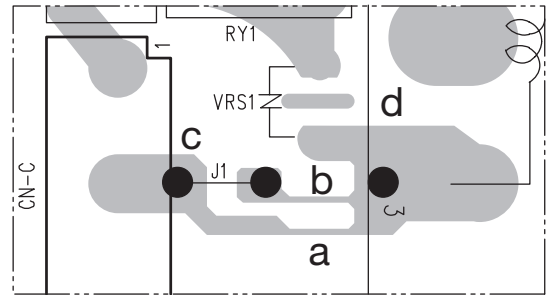

Procedure Letter	Component Test
N	9) Disconnect the power supply cord. 10) Open the door and block it open. 11) Reconnect all leads removed from components during testing. 12) Re-install the hood intake duct R. 13) Re-install the outer case (cabinet). 14) Reconnect the power supply cord after the outer case is installed. 15) Run the oven and check all functions.
O	<p>HUMIDITY SENSOR TEST</p> <p>Checking the initial sensor cooking condition WARNING : The oven should be fully assembled before following procedure.</p> <ol style="list-style-type: none"> (1) The oven should be plugged in at least two minutes before sensor cooking. (2) Room temperature should not exceed 95 F (35 C). (3) The unit should not be installed in any area where heat and steam are generated. The unit should not be installed, for example, next to a conventional surface unit. Refer to the "INSTALLATION INSTRUCTIONS" of the operation manual. (4) Exhaust vents are provided on the back of the unit for proper cooling and air flow in the cavity. To permit adequate ventilation, be sure to install so as not to block these vents. There should be some space for air circulation. (5) Be sure the exterior of the cooking container and the interior of the oven are dry. Wipe off any moisture with a dry cloth or paper towel. (6) The Sensor works with food at normal storage temperature. For example, chicken pieces would be at refrigerator temperature and canned soup at room temperature. (7) Avoid using aerosol sprays or cleaning solvents near oven while using Sensor settings. The sensor will detect vapor given off by the spray and turn off before food is properly cooked. (8) If the sensor has not detected the vapor of the food, ERROR will appear and the oven will shut off. <p>Water load cooking test WARNING : The oven should be fully assembled before following procedure. Make sure the oven has been plugged in at least two minutes before checking sensor cook operation. The cabinet should be installed and screws tightened.</p> <ol style="list-style-type: none"> (1) Fill approximately 200 milliliters (7.2 oz) of tap water in a 1000 milliliter measuring cup. (2) Place the container on the center of tray in the oven cavity. (3) Close the door. (4) Touch the TIMER/CLOCK once, the POWER LEVEL pad twice, the START pad once, the number pad 1 once and the number pad 4 once. Now, the oven is in the sensor cooking condition, and " AH20 ", " SENSOR " and " COOK " will appear in the display. (5) The oven will operate for the first 32 seconds, without generating microwave energy. <p>NOTE: ERROR will appear if the door is opened or STOP/CLEAR pad is touched during first stage of sensor cooking.</p> <ol style="list-style-type: none"> (6) After approximately 32 seconds, microwave energy is produced. If ERROR is displayed or the oven does not turn off, replace the humidity sensor or check the control unit, refer to explanation below. If the oven stops after 5 minutes and ERROR is displayed, the humidity sensor is normal. Check other parts except the Humidity sensor.

Procedure Letter	Component Test
<p>O</p>	<p>TESTING METHOD FOR HUMIDITY SENSOR AND/OR CONTROL UNIT</p> <p>To determine if the sensor is defective, the simplest method is to replace it with a new replacement sensor.</p> <ol style="list-style-type: none"> (1) Disconnect the power supply cord, and then remove outer case. Refer to procedure of “HOOD LOUVER REMOVAL”, “REMOVAL OF OVEN FROM wall ” and “OUTER CASE REMOVAL”. (2) Open the door and block it open. (3) Remove the humidity sensor. (4) Install the new humidity sensor. (5) Reconnect all leads removed from components during testing. (6) Re-install the outer case (cabinet). (7) Reconnect the power supply cord after the outer case is installed. (8) Reconnect the oven to the power supply and check the sensor cook operation as follows: <ol style="list-style-type: none"> 8-1. Fill approximately 200 milliliters (7.2 oz) of tap water in a 1000 milliliter measuring cup. 8-2. Place the container on the center of tray in the oven cavity. 8-3. Close the door. 8-4. Touch the TIMER/CLOCK pad once, the POWER LEVEL pad twice, the START pad once, the number pad 1 once and the number pad 4 once. 8-5. The control panel is in automatic Sensor operation. 8-6. The oven turns off automatically, and the time for detecting moisture will be displayed. <p>If new sensor dose not operate properly, the problem is with the control unit, and refer to explanation below.</p> <p>CHECKING CONTROL UNIT</p> <ol style="list-style-type: none"> (1) Disconnect the power supply cord, and then remove outer case. Refer to procedure of “HOOD LOUVER REMOVAL”, “REMOVAL OF OVEN FROM wall ” and “OUTER CASE REMOVAL”. (2) Open the door and block it open. (3) Disconnect the sensor connector that is mounted to control panel. (4) Then connect the dummy resistor circuit (see fig.) to the sensor connector of control panel. (5) Disconnect the leads to the primary of the inverter unit. (6) Ensure that these leads remain isolated from other components and oven chassis by using insulation tape. (7) After that procedure, re-connect the power supply cord. (8) Check the sensor cook operation proceed as follows: <ol style="list-style-type: none"> 8-1. Touch the TIMER/CLOCK pad once, the POWER LEVEL pad twice, the START pad once and the number pad 1 once and the number pad 4 once. 8-2. The control panel is in the sensor cooking operation. 8-3. After approximately 65 seconds, push plunger of select switch for more than 3 seconds. This condition is same as judgement by humidity sensor. 8-4. After approximately 3 seconds, the display shows “ X X . X X ” which is the time for detecting moisture. <p>If the above is not the case, the control unit is probably defective. If the above is proper, the humidity sensor is probably defective.</p>

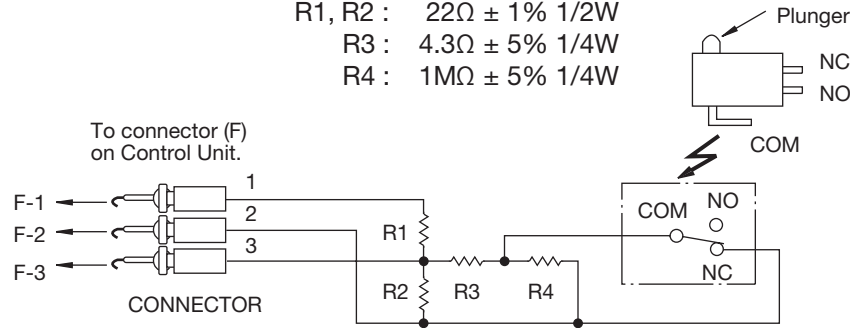
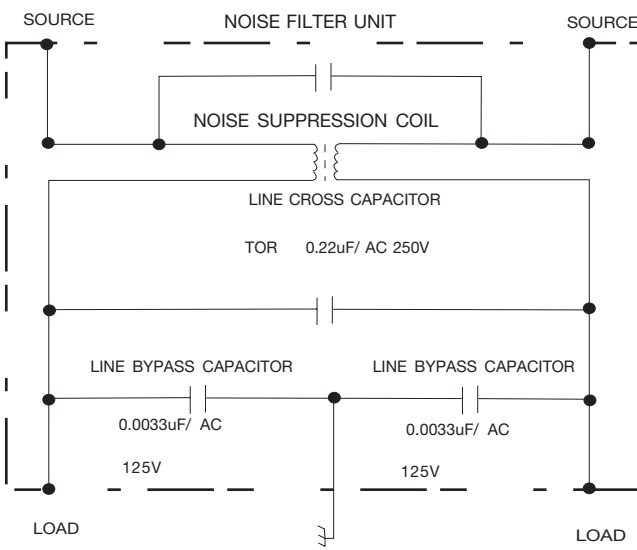
Procedure Letter	Component Test								
<p>O</p>	<p>(10) Disconnect the power supply cord, and then remove outer case. (11) Open the door and block it open. (12) Disconnect the dummy resistor circuit from the sensor connector of control panel. (13) Carry out necessary repair. (14) Reconnect all leads removed from components during testing and repairing. (15) Re-install the outer case (cabinet). (16) Reconnect the power supply cord after the outer case is installed. Run the oven and check all functions. (17) Carry out "Water load cooking test" again and ensure that the oven works properly.</p> <p style="text-align: center;"> R1, R2 : $22\Omega \pm 1\%$ 1/2W R3 : $4.3\Omega \pm 5\%$ 1/4W R4 : $1M\Omega \pm 5\%$ 1/4W </p>  <p style="text-align: center;">Sensor Dummy Resistor Circuit</p>								
<p>P</p>	<p>NOISE FILTER TEST</p> <ol style="list-style-type: none"> Disconnect the power supply cord, and then remove outer case. Open the door and block it open. Disconnect the leads to the primary of the power transformer. Using an ohm-meter, check between the terminals as described in the following table on the right: Reconnect all leads removed from components during testing. Re-install the outer case (cabinet). Reconnect the power supply cord after the outer case is installed. Run the oven and check all functions.  <table border="1" data-bbox="820 1753 1437 1921"> <thead> <tr> <th colspan="2">MEASURING POINT</th> </tr> </thead> <tbody> <tr> <td>Between source and source</td> <td>Open</td> </tr> <tr> <td>Between terminal source and load</td> <td>Short Circuit</td> </tr> <tr> <td>Between terminal source and load</td> <td>Short Circuit</td> </tr> </tbody> </table>	MEASURING POINT		Between source and source	Open	Between terminal source and load	Short Circuit	Between terminal source and load	Short Circuit
MEASURING POINT									
Between source and source	Open								
Between terminal source and load	Short Circuit								
Between terminal source and load	Short Circuit								

Section 4

Component Teardown

Servicing

1. Precautions for Handling Electronic Components

This unit uses CMOS LSI in the integral part of the circuits. When handling these parts, the following precautions should be strictly followed. CMOS LSI have extremely high impedance at its input and output terminals. For this reason, it is easily influenced by the surrounding high voltage power source, static electricity charge in clothes, etc. and sometimes it is not fully protected by the built-in protection circuit.

In order to protect CMOS LSI.

- 1) When storing and transporting, thoroughly wrap them in aluminum foil. Also wrap all PW boards containing them in aluminum foil.
- 2) When soldering, ground the technician as shown in the figure and use grounded soldering iron and work table.

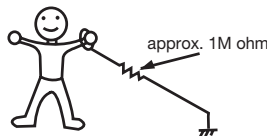

2. Servicing of Touch Control Panel

We describe the procedures to permit servicing of the touch control panel of the microwave oven and the precautions you must take when doing so. To perform the servicing, power to the touch control panel is available either from the power line of the oven itself or from an external power source.

- (1) Servicing the touch control panel with power supply of the oven:

CAUTION:

THE HIGH VOLTAGE PARTS OF THE MICROWAVE OVEN IS STILL LIVE DURING SERVICING AND PRESENTS A HAZARD.

Therefore, before checking the performance of the touch control panel,

- 1) Disconnect the power supply cord, and then remove outer case.
- 2) Open the door and block it open.
- 3) Disconnect the leads to the primary of the power transformer.
- 4) Ensure that these leads remain isolated from other components and oven chassis by using insulation tape.
- 5) After that procedure, re-connect the power supply cord.

After checking the performance of the touch control panel,

- 1) Disconnect the power supply cord.
 - 2) Open the door and block it open.
 - 3) Re-connect the leads to the primary of the inverter unit.
 - 4) Re-install the outer case (cabinet).
 - 5) Re-connect the power supply cord after the outer case is installed.
 - 6) Run the oven and check all functions.
- A. On some models, the power supply cord between the touch control panel and the oven itself is so short that the two can't be separated. For those models, check and repair all the controls (sensor-related ones included) of the touch control panel while keeping it connected to the oven.
- B. On some models, the power supply cord between the touch control panel and the oven proper is long enough that they may be separated from each other. For those models, it is possible to check and repair the controls of the touch control panel while keeping it apart from the oven proper; in this case you must short both ends of the door sensing switch (on PWB) of the touch control panel with a jumper, which activates an operational state that is equivalent to the oven door being closed. As for the sensor related controls of the touch control panel, checking them is possible if dummy resistor(s) with resistance equal to that of the controls are used.
- (2) Servicing the touch control panel with power supply from an external power source:
Disconnect the touch control panel completely from the oven proper, and short both ends of the door sensing switch (on PWB) of the touch control panel, which activates an operational state that is equivalent to the oven door being closed. Connect an external power source to the power input terminal of the touch control panel, then it is possible to check and repair the controls of the touch control panel it is also possible to check the sensor-related controls of the touch control panel by using the dummy resistor(s).

3. Servicing Tools

Tools required to service the touch control panel assembly.

- 1) Soldering iron: 30W
(It is recommended to use a soldering iron with a grounding terminal.)
- 2) Oscilloscope: Single beam, frequency range: DC-10MHz type or more advanced model.
- 3) Others: Hand tools

4. Other Precautions

- 1) Before turning on the power source of the control unit, remove the aluminum foil applied for preventing static electricity.
- 2) Connect the connectors of the key unit to the control unit being sure that the lead wires are not twisted.
- 3) After aluminum foil is removed, be careful that abnormal voltage due to static electricity etc. is not applied to the input or output terminals.
- 4) Attach connectors to PWB, making sure that all connections are tight.
- 5) Be sure to use specified components where high precision is required.

3. Soldering

As the melting point of lead-free solder (Sn-Ag-Cu) is higher and has poorer wettability, (flow), to prevent damage to the land of the PWB, extreme care should be taken not to leave the bit in contact with the PWB for an extended period of time. Remove the bit as soon as a good flow is achieved. The high content of tin in lead free solder will cause premature corrosion of the bit. To reduce wear on the bit, reduce the temperature or turn off the iron when it is not required.

Leaving different types of solder on the bit will cause contamination of the different alloys, which will alter their characteristics, making good soldering more difficult. It will be necessary to clean and replace bits more often when using lead-free solder. To reduce bit wear, care should be taken to clean the bit thoroughly after each use.

Precautions for Using Lead-Free Solder

1. Employing lead-free solder

The "Control unit PWB and Inverter unit PWB" of this model employs lead-free solder. This is indicated by the "LF" symbol printed on the PWB and in the service manual. The suffix letter indicates the alloy type of the solder.

Example:

LFa
Sn-Ag-Cu

Indicates lead-free solder of tin, silver and copper.

2. Using lead-free wire solder

When repairing a PWB with the "LF" symbol, only lead-free solder should be used. (Using normal tin/lead alloy solder may result in cold soldered joints and damage to printed patterns.) As the melting point of lead-free solder is approximately 40 C higher than tin/lead alloy solder, it is recommend that a dedicated bit is used, and that the iron temperature is adjusted accordingly.

 **WARNING**

HIGH VOLTAGE

MICROWAVE OVENS CONTAIN CIRCUITRY CAPABLE OF PRODUCING VERY HIGH VOLTAGE AND CURRENT, CONTACT WITH FOLLOWING PARTS MAY RESULT IN SEVERE, POSSIBLY FATAL, ELECTRIC SHOCK.

(EXAMPLE)

MAGNETRON, INVERTER UNIT, HIGH VOLTAGE HARNESS ETC..

 **WARNING**

AVOID POSSIBLE EXPOSURE TO MICROWAVE ENERGY. PLEASE FOLLOW THE INSTRUCTIONS BELOW BEFORE OPERATING THE OVEN.

1. DISCONNECT THE POWER SUPPLY CORD.
2. MAKE SURE THAT A DEFINITE "CLICK" CAN BE HEARD WHEN THE MICROWAVE OVEN DOOR IS UNLATCHED. (HOLD THE DOOR IN A CLOSED POSITION WITH ONE HAND, THEN PUSH THE DOOR OPEN BUTTON WITH THE OTHER, THIS CAUSES THE LATCH LEADS TO RISE, IT IS THEN POSSIBLE TO HEAR A "CLICK" AS THE DOOR SWITCHES OPERATE.)
3. VISUALLY CHECK THE DOOR AND CAVITY FACE PLATE FOR DAMAGE (DENTS, CRACKS, SIGNS OF ARCING ETC.).

CARRY OUT ANY REMEDIAL WORK THAT IS NECESSARY BEFORE OPERATING THE OVEN. DO NOT OPERATE THE OVEN IF ANY OF THE FOLLOWING CONDITIONS EXIST;

1. DOOR DOES NOT CLOSE FIRMLY.
2. DOOR HINGE, SUPPORT OR LATCH HOOK IS DAMAGED.
3. THE DOOR GASKET OR SEAL IS DAMAGED.
4. THE DOOR IS BENT OR WARPED.
5. THERE ARE DEFECTIVE PARTS IN THE DOOR INTERLOCK SYSTEM.
6. THERE ARE DEFECTIVE PARTS IN THE MICROWAVE GENERATING AND TRANSMISSION ASSEMBLY.
7. THERE IS VISIBLE DAMAGE TO THE OVEN.

DO NOT OPERATE THE OVEN:

1. WITHOUT THE RF GASKET (MAGNETRON).
2. IF THE WAVE GUIDE OR OVEN CAVITY ARE NOT INTACT.
3. IF THE DOOR IS NOT CLOSED.
4. IF THE OUTER CASE (CABINET) IS NOT FITTED.

WARNING

TO PREVENT AN ELECTRIC SHOCK, TAKE THE FOLLOWING PRECAUTIONS.

- 1. BEFORE WIRING,**
 - 1) DISCONNECT THE POWER SUPPLY CORD.**
 - 2) OPEN THE DOOR BLOCK IT OPEN.**
- 2. DON'T LET THE WIRE LEADS TOUCH TO THE FOLLOWING PARTS;**
 - 1) HIGH VOLTAGE PARTS:
MAGNETRON AND INVERTER UNIT.**
 - 2) HOT PARTS:
OVEN LAMP, HOOD LAMPS, MAGNETRON, INVERTER UNIT AND OVEN CAVITY.**
 - 3) SHARP EDGE: ALL PARTS
(BOTTOM PLATE, OVEN CAVITY, WAVEGUIDE FLANGE, CHASSIS SUPPORT AND OTHER METALLIC PLATE.)**
 - 4) MOVABLE PARTS (TO PREVENT A FAULT)
FAN BLADE, FAN MOTOR, SWITCH, OPEN LEVER, OPEN BUTTON, STIRRER MOTORS, STIRRER FANS, DOOR PARTS.**
- 3. DO NOT CATCH THE WIRE LEADS IN THE OUTER CASE CABINET.**
- 4. INSERT THE POSITIVE LOCK CONNECTOR UNTIL ITS PIN IS LOCKED AND MAKE SURE THAT THE WIRE LEADS DO NOT COME OFF EVEN IF THE WIRE LEADS ARE PULLED.**
- 5. TO PREVENT AN ERROR FUNCTION, CONNECT THE WIRE LEADS CORRECTLY, REFERRING TO THE PICTORIAL DIAGRAM.**

Please refer to 'OVEN PARTS, CABINET PARTS, CONTROL PANEL PARTS, DOOR PARTS', when carrying out any of the following removal procedures:

THE FOLLOWING ADJUSTMENTS OR COMPONENT REPLACEMENT CAN BE PERFORMED WITHOUT REMOVING THE OVEN FROM THE WALL

1. Oven lamp, hood lamps, hood lamp sockets, grease filter and charcoal filter.
2. Base cover, hood lamp glass assembly, bottom sash.
3. Stirrer motors.
4. Hood louver.
5. Control panel assembly or components.
6. Table tray assembly
7. Stirrer fan
8. Antenna plate assembly
9. Control unit

Hood Louver Removal

1. Disconnect the power supply cord.
2. Open the door and block it open.
3. Remove the three (3) screws holding the hood louver to the oven cavity front face plate and the outer case screw at the top middle.
4. Pull the hood louver from the oven cavity by pushing the right and left tabs of the hood louver to remove.
5. Now, the hood louver is free.

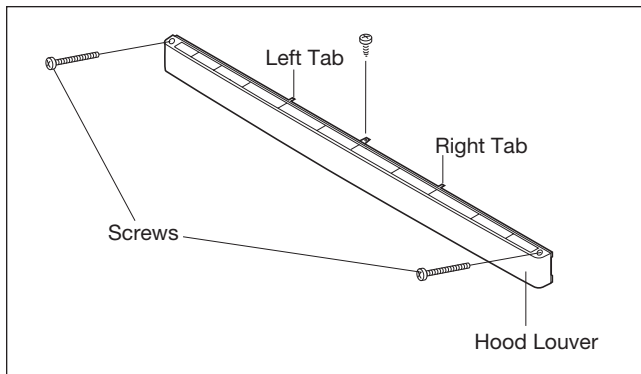

Removal of Oven From Wall

1. Disconnect the power supply cord, and uncoil the power supply cord.
2. If the exhaust damper assembly is installed, remove the one (1) screw holding the exhaust damper assembly to the rear stay, and remove the exhaust damper assembly by sliding it backward.
3. Remove the two (2) bottom mounting plate screws holding the oven to the base plate.
4. While supporting the front of the oven, remove two (2) tapping screws from the outer case and release the oven from the unit mounting plate.
5. Pull the power cord out of the wall cabinet and remove the oven.
6. The oven is now free and can be placed on the work surface selected for servicing the oven.
7. Installation is the reverse of this procedure.

Outer Case Removal

Remove the oven from the wall, referring to "Removal of oven from wall " and proceed as follows:

1. Disconnect the power supply cord.
2. Open the door and block it open.
3. Remove five (5) screws holding the rear stay to the outer case cabinet, hood fan motor or the oven, and remove it.
4. Remove the six (6) screws from the rear of the outer case cabinet and one (1) screw at front.
5. Slide the outer case cabinet back about 1 inch (3 cm) to free it from retaining clips on the cavity face plate.
6. Disconnect the three (3) pin connector of the power supply cord from the wiring harness and remove the power supply cord together with the outer case.
7. Nip the cord bushing with bushing pliers and release it from the outer case cabinet.
8. Remove the cord bushing and the power supply cord from the outer case cabinet.
9. Now, the power supply cord or the outer case cabinet is free.

CAUTION

Disconnect oven from power supply before removing outer case.

Hood Fan Motor Removal

1. Disconnect the power supply cord and remove the oven from wall and remove outer case. (Refer to procedure of "Removal of Oven from Wall" and "Outer Case Removal")
2. Open the door and block it open.
3. Disconnect the 6-pin connector of the hood fan motor from the main wire harness located at the right edge of the oven cavity top plate and release the snap band from the hood duct.
4. Remove the hood fan motor from the oven cavity top plate by lifting it up.
5. Now, the hood fan motor is free.

Magnetron Removal

1. Disconnect the power supply cord and remove the oven from wall and remove outer case. (Refer to procedure of "Removal of Oven from Wall" and "Outer Case Removal")
2. Open the door and block it open.
3. Remove the seven (7) screws holding the hood intake duct R to the oven cavity top plate, the oven cavity front flange, the fan duct and magnetron duct. Remove the hood intake duct R.
4. Disconnect the high voltage wire from the magnetron.
5. Release the two (2) tabs of the fan duct from the base plate R.
6. Remove the magnetron duct from the oven cavity, by releasing the tab of the magnetron duct from the base plate R.
7. Remove the grease filter (right side one) from the base cover.
8. Carefully remove four (4) mounting screws holding the magnetron to waveguide. When removing the screws hold the magnetron to prevent it from falling.
9. Remove the magnetron from the unit with care so the magnetron tube should not be hit by any metal object around the tube.

CAUTION

When replacing the magnetron, be sure the R.F. Gasket is in place and mounting screws are tightened securely.

Hood Fan Thermal Cut-out Removal

1. Disconnect the power supply cord and remove the oven from wall and remove outer case. (Refer to procedure of "Removal of Oven from Wall" and "Outer Case Removal")
2. Open the door and block it open.
3. Remove the seven (7) screws holding the hood intake duct R to the oven cavity top plate, the oven cavity front flange, the fan duct and magnetron duct. And remove the hood intake duct R.
4. Disconnect the wire leads from the hood fan thermal cut-out.
5. Remove one (1) screw holding the thermal cut-out to the flange of base plate R.
6. Remove the hood fan thermal cut-out from the base plate R.
7. Now, the hood fan thermal cut-out is free.

Oven Thermal Cut-out Removal

1. Disconnect the power supply cord and remove the oven from wall and remove outer case. (Refer to procedure of "Removal of Oven from Wall" and "Outer Case Removal")
2. Open the door and block it open.
3. Disconnect the wire leads from the oven thermal cutout.
4. Remove the oven thermal cut-out from the holder at the oven cavity top plate.
5. Now, the oven thermal cut-out is free.

Inverter Unit and Fan Motor Replacement

Removal

1. Disconnect the power supply cord and remove the oven from wall and remove outer case. (Refer to procedure of "Removal of Oven from Wall" and "Outer Case Removal")
2. Open the door and block it open.
3. Remove the seven (7) screws holding the hood intake duct R to the oven cavity top plate, the oven cavity front flange, the fan duct and magnetron duct.
4. Remove the hood intake duct R.
5. Disconnect the main wire harness and the stop/pwm wire harness from the inverter unit.
6. Disconnect the high voltage wire from the magnetron.
7. Disconnect the wire leads from the fan motor.
8. Disconnect the green wire (grounding wire) from the fan duct.
9. Disconnect the connector between the main wire harness and the hood fan motor.
10. Release the two (2) connectors of the main wire harness from the oven cavity top plate.
11. Disconnect the main wire harness from the oven lamp harness.
12. Disconnect the wire leads from the fuse holder.
13. Remove the one (1) screw holding the hood duct R to the oven cavity top plate.
14. Remove the hood duct R from the oven cavity top plate.
15. Remove the one (1) screw holding the fan duct to the oven cavity top plate.
16. Remove the fan duct with the inverter unit and the fan motor from the oven.
17. Remove the three (3) screws holding the inverter unit to the fan duct.
18. Disconnect the high voltage wire from the inverter unit.
19. Now, the inverter unit is free.
20. Remove the fan blade from the fan motor shaft. Refer to "METHOD FOR REMOVING FAN BLADE".
21. Remove the two (2) screws holding the fan motor to the fan duct.
22. Now, the fan motor is free.

Reinstallation

1. Install the fan motor to the fan duct with the two (2) screws.
2. Install the fan blade to the fan motor shaft. Refer to "METHOD FOR INSTALLING FAN BLADE".
3. Now, the fan motor should be installed.
4. Install the inverter unit to the fan duct with the two (2) screws XOTSD40P12000 (4mm x 12mm).
5. Ground the inverter unit to the fan duct with the one (1) screw XHTSD40P08RV0 (4mm x 8mm with a washer).
6. Install the fan duct (assembly) to the oven cavity top plate with the one (1) screw.
7. Install the hood duct R to the oven cavity top plate with the one (1) screw.
8. Reinstall the two connectors of the main wire harness into the holes in the oven cavity top plate.
9. Reconnect all wire leads and connectors to the inverter unit, fan motor, magnetron, fuse holder and fan duct, referring to the pictorial diagram.
10. Reconnect the connectors between the main wire harness and the oven lamp harness, referring to the pictorial diagram.
11. Reconnect the connector of the hood fan motor to the main wire harness, referring to the pictorial diagram.
12. Reinstall the wire leads to the hole of the fan duct.
13. Reinstall the hood intake duct R to the oven cavity top plate, oven cavity front flange, fan duct, base plate R and magnetron duct with the seven (7) screws.
14. Refer to the procedures of "OUTER CASE REMOVAL". And reverse their procedures. And reinstall the outer case cabinet.

Method for Removing Fan Blade

1. Hold the edge of the rotor of the fan motor by using a pair of groove joint pliers.

CAUTION

Make sure that any pieces do not enter the gap between the rotor and the stator of the fan motor because the rotor is easily shaven by pliers and metal pieces may be produced.

- * Do not touch the pliers to the coil of the fan motor because the coil may be cut or damaged.
- * Do not disfigure the bracket by touching with the pliers.

2. Remove the fan blade from the shaft of the fan motor by pulling and rotating the fan blade with your hand.
3. Now, the fan blade will be free.

CAUTION

Do not reuse the removed fan blade because the hole (for shaft) may be larger than normal.

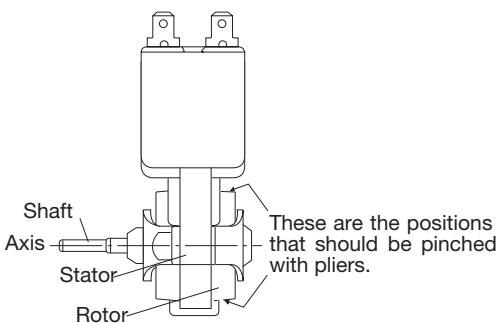
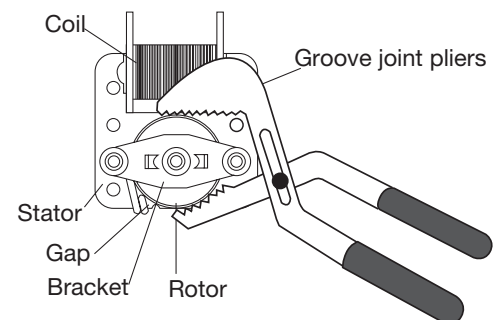

Method for Installing Fan Blade

1. Hold the center of the bracket which supports the shaft of the fan motor on the flat table.
2. Install the fan blade to the shaft of fan motor by pushing the fan blade with a small, light weight, ball peen hammer or rubber mallet.

CAUTION

- * Do not hit the fan blade with excessive force when installing because the bracket may be disfigured.
- * Make sure that the fan blade rotates smooth after installation.
- * Make sure that the axis of the shaft is not slanted.

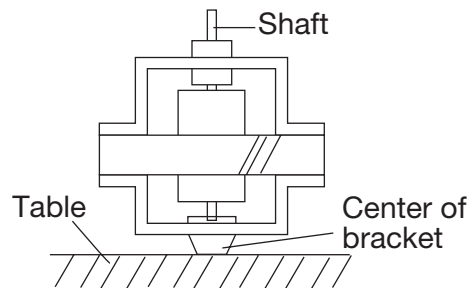

Stirrer Motors Replacement

Removal

1. Disconnect the power supply cord.
2. Open the door and block it open.
3. Remove the five (5) screws holding the bottom sash to the base cover.
4. Remove the three (3) screws holding the base cover to the oven cavity front face plate.
5. Open the base cover.

Stirrer motor (left one)

6. Disconnect the wire leads from the stirrer motor (left one).
7. Remove the two (2) screws holding the stirrer motor to the oven cavity.
8. Now, the stirrer motor (left one) is free.

Stirrer motor (right one)

6. Disconnect the wire leads from the stirrer motor (right one).
7. Remove the two (2) screws holding the motor mounting angle to the oven cavity.
8. Remove the two (2) screws holding the stirrer motor to the motor mounting angle.
9. Now, the stirrer motor (right one) is free.

Reinstallation

1. Insert a putty knife into the gap between the table tray assembly and the oven cavity front plate. And remove the table tray assembly from the oven cavity.
2. Install the stirrer motor (left one) to the oven cavity with the two (2) screws.
3. Reconnect the wire lead to the stirrer motor (left one), referring to the pictorial diagram.
4. Make sure that the stirrer motor gear, stirrer shaft assembly and shield spring are installed to the motor mounting angle.
5. Install the stirrer motor (right one) to the motor mounting angle with the two (2) screws.
6. Install the motor mounting angle to the oven cavity with the two (2) screws.
7. Reconnect the wire leads to the stirrer motor (right one), referring to the pictorial diagram.
8. Reinstall the two (2) stirrer fans to the two (2) stirrer shafts.
9. Reinstall the table tray assembly to the oven cavity.

Stirrer Fan Assembly Installation

1. Make sure that the stirrer fan faces upside, as shown in the following figure. The upside of the stirrer fan is engraved with the part number.
2. Install the three stirrer spacers to the stirrer fan, as shown in the following figure.
3. Install the stirrer fan to the stirrer shaft.

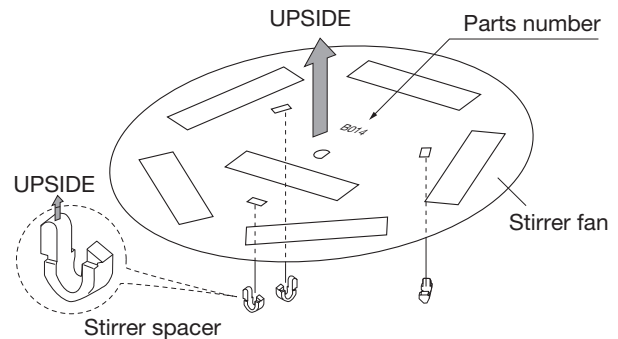

Hood Lamp Sockets Removal

1. Disconnect the power supply cord.
2. Open the door and block it open.
3. Remove the five (5) screws holding the bottom sash to the base cover.
4. Remove the three (3) screws holding the base cover to the oven cavity front face plate.
5. Open the base cover.
6. Screw the hood lamp off from the lamp socket.
7. Disconnect the wire leads from the lamp socket.
8. Push the tab holding the lamp socket to the hood lamp mount.
9. Remove the lamp socket from the hood lamp mount.
10. Now, the lamp socket is free.

Oven Lamp and Lamp Socket Removal

1. Disconnect the power supply cord.
2. Open the door and block it open.
3. Remove one (1) screw holding the hood duct R to the oven cavity top plate.
4. Release the hood duct R from the oven cavity top plate by lifting it up.
5. Disconnect the wire leads from the lamp socket.
6. Remove the oven lamp angle from the hood duct R by pushing the two (2) tabs holding the oven lamp angle..
7. Screw the oven lamp off from the lamp socket.
8. Now, the oven lamp is free.
9. Remove the lamp socket from the oven lamp angle by pushing the tab holding the lamp socket.
10. Now, the oven lamp socket is free.

Positive Lock ® Connector (No-Case Type) Removal

1. Disconnect the power supply cord and remove the oven from wall and remove outer case. (Refer to procedure of "Removal of Oven from Wall" and "Outer Case Removal")
2. Open the door and block it open.
3. Push the lever of positive lock ® connector.
4. Pull down on the positive lock ® connector.

CAUTION

When connecting the positive lock ® connectors to the terminals, install the positive lock ® so that the lever faces you.

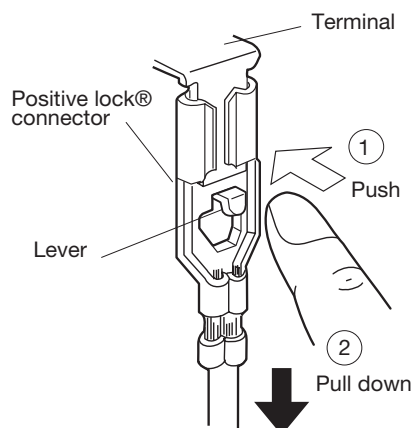

Control Panel Assembly, Control Unit and Key Unit Removal

1. Disconnect the power supply cord.
2. Open the door and block it open.
3. Remove three (3) screws holding the hood louver to oven cavity front face plate.
4. Remove the hood louver from the oven by pushing the right and left tabs of the hood louver. (Refer to procedure of "HOOD LOUVER REMOVAL")
5. Remove one (1) screw holding the control panel to the oven cavity front face plate.
6. Release the control panel from the oven cavity front face plate by lifting it up.
7. Disconnect the wire leads from the relay.
8. Disconnect all connectors from the control unit.
9. Remove the control panel assembly from the oven.
10. Now, the control panel assembly is free.
11. Disconnect the connector CN-G from the control unit.
12. Remove three (3) screws holding the control unit to the key fixing angle.
13. Release the two (2) tabs holding the control unit to the key fixing plate.
14. Now, the control unit is free.
15. Remove the one (1) screw holding the key fixing angle to the control panel.
16. Release the seven (7) tabs holding the key fixing angle to the control panel.
17. Remove the key fixing angle from the control panel.
18. Remove the key unit from the key fixing angle.
19. Now, the key unit is free.

NOTES FOR KEY UNIT REPLACEMENT

1. Do not reuse the torn key unit because the performance of the adhesive becomes weak.
2. Before attaching a new key unit, wipe off remaining adhesive on the key fixing angle surfaces completely with a soft cloth soaked in alcohol.
3. When attaching the key unit to the key fixing angle, adjust the upper edge and right edge of the key unit to the correct position of key fixing angle.
4. Stick the key unit firmly to the key fixing angle by rubbing with soft cloth not to scratch.

Humidity Sensor Removal

1. Disconnect the power supply cord and remove the oven from wall and remove outer case. (Refer to procedure of "Removal of Oven from Wall" and "Outer Case Removal")
2. Open the door and block it open.
3. Remove seven (7) screws holding the hood intake duct R to the oven cavity top plate, the oven cavity front flange, fan duct, base plate R, and magnetron duct. And remove the hood intake duct R.
4. Disconnect the connector CN-F of humidity sensor from the control unit.
5. Remove the two (2) screws and one (1) washer holding the humidity sensor to the hood duct L.
6. Release the wire lead of humidity sensor from the holes of the hood ducts L and R.
7. Now, the humidity sensor is free.

NOTE: When the humidity sensor is reinstalled, the wire tie of the humidity sensor should be positioned through the hole of the oven cavity top plate (right).

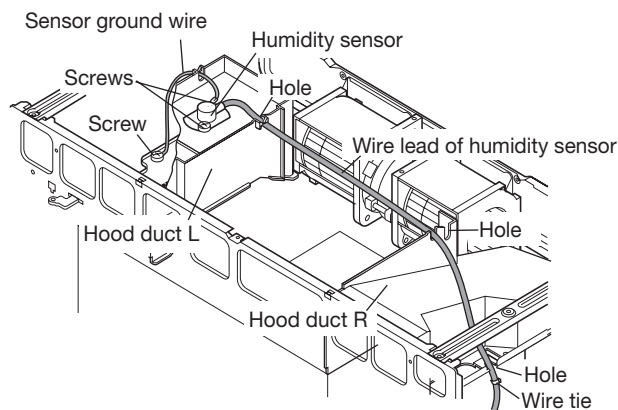

This illustration is under the condition which hood intake duct R is removed.

Noise Filter Removal

1. Disconnect the power supply cord and remove the oven from wall and remove outer case.
2. Open the door and block it open.
3. Disconnect the wire leads from the terminals of the noise filter .
4. Remove one (1) screw mounted into the noise filter and chassis support.
5. Now the noise filter is free.

Table Tray Assembly Removal

Removal

1. Open the door and block it open.
2. Insert a putty knife into the gap between the table tray assembly and the oven cavity front plate. And lift up the front edge of the table tray assembly.
3. Remove the table tray assembly from the oven cavity.
4. Now, the table tray assembly is free.

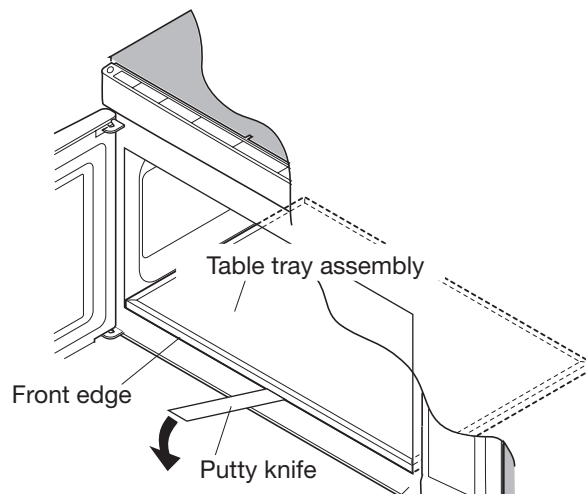

Reinstallation

1. Remove the two (2) stirrer fans.
2. Clean the oven cavity bottom plate and /or under the antenna plate assembly by a vacuum cleaner.
3. Reinstall the two (2) stirrer fans to the stirrer shafts.
4. Make sure that the flat edge of the table tray assembly faces front. And place the table tray assembly into the oven cavity.
5. At first, insert the front edge of the table tray assembly into the oven cavity. And then push the rear edge of the table tray assembly.

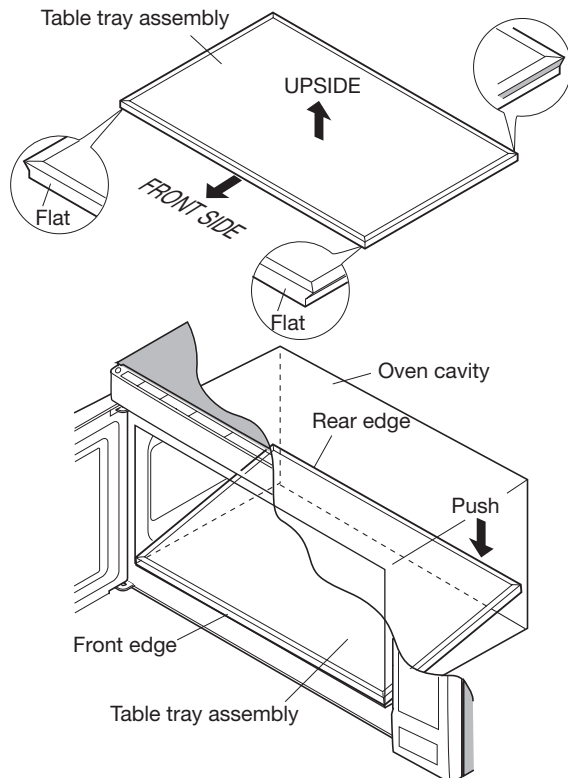

Stop Switch, Primary Interlock Switch, Secondary Interlock Switch and Monitor Switch

1. Disconnect the power supply cord and remove the oven from wall and remove outer case. (Refer to procedure of "Removal of Oven from Wall" and "Outer Case Removal")
2. Open the door and block it open.
3. Remove seven (7) screws holding the hood intake duct R to the oven cavity top plate, the oven cavity front flange, fan duct, base plate R, and magnetron duct. And remove the hood intake duct R.
4. Remove the control panel assembly, referring to the procedure of "CONTROL PANEL ASSEMBLY CONTROL UNIT AND KEY UNIT REMOVAL".
5. Remove the two (2) screws holding the latch hook to the oven cavity front flange.
6. Remove the latch hook from the oven cavity front flange.
7. Disconnect the wire leads of each switch.
8. Remove each switch from the latch hook by pushing the one (1) stopper tab holding each switch.
9. Now, each switch is free.

Re-install

1. Re-install each switch in its place. The secondary interlock switch is in the lower position, stop switch is in the upper position and the primary interlock switch is in the upper position under the stop switch. And the monitor switch is in the middle position.
2. Re-connect wire leads to each switch. Refer to pictorial diagram.
3. Secure the latch hook (with two (2) mounting screws) to oven cavity front flange.
4. Make sure that the monitor switch is operating properly and check continuity of the monitor circuit. Refer to chapter "Test Procedure" and "Adjustment procedure".

Stop Switch, Primary Interlock Switch, Secondary Interlock Switch and Monitor Switch Adjustment

1. Disconnect the power supply cord and remove the oven from wall and remove outer case. (Refer to procedure of "Removal of Oven from Wall" and "Outer Case Removal")
2. Open the door and block it open.
3. Remove seven (7) screws holding the hood intake duct R to the oven cavity top plate, the oven cavity front flange, fan duct, base plate R, and magnetron duct. And remove the hood intake duct R.
4. Remove the control panel assembly, referring to the procedure of "CONTROL PANEL ASSEMBLY CONTROL UNIT AND KEY UNIT REMOVAL".
5. Remove the two (2) screws holding the latch hook to the oven cavity front flange.
6. With door closed, adjust latch hook by moving it back and forth, and up and down. In and out play of the door allowed by the upper and lower position of the latch hook should be less than 0.5mm. The vertical position of the latch hook should be adjusted so that the secondary interlock switch and primary interlock switch are activated with the door closed. The horizontal position of the latch hook should be adjusted so that the monitor switch and stop switch are activated with the door closed.
7. Secure the screws with washers firmly.
8. Check all of the switches operation. If any switch has not activated with the door closed, loosen screw and adjust the latch hook position.

After adjustment, check the following:

1. In and out play of door remains less than 0.5mm when in the latched position. First check upper position of latch hook, pushing and pulling upper portion of door toward the oven face. Then check lower portion of the latch hook, pushing and pulling lower portion of the door toward the oven face. Both results (play in the door) should be less than 0.5mm.
2. The secondary interlock switch and primary interlock switch interrupt the circuit before the door can be opened.
3. Monitor switch contacts close when door is opened.
4. Stop switch contacts open when door is opened.
5. Re-install outer case and check for microwave leakage around door with an approved microwave survey meter. (Refer to Microwave Measurement Procedure.) the latch hook position.

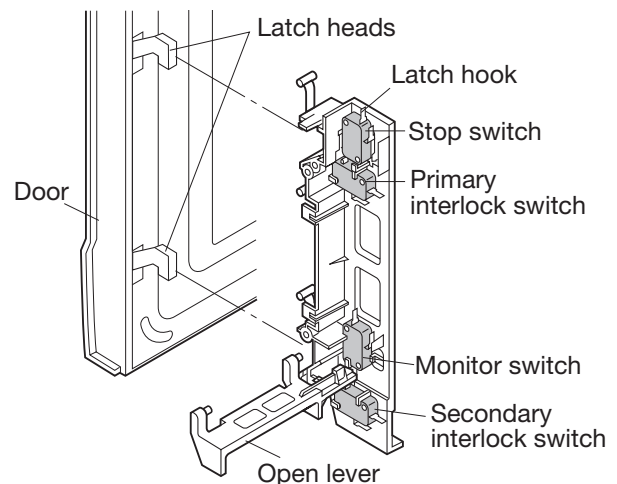

Figure C-1. Latch Switch Adjustments

Door Replacement

1. Disconnect the power supply cord.
2. Open the door and block it open.
3. Remove the three (3) screws holding the hood louver to the oven cavity front face plate.
4. Remove the hood louver from the oven cavity by pushing the right and left tabs of the hood louver. (Refer to the procedure of "HOOD LOUVER REMOVAL".)
5. Insert a putty knife (thickness of about 0.5mm) into the gap A between the door stopper and the choke cover as shown in Figure C-3 to free engaging parts.
6. Lift up the door stopper.
7. Now, the door stopper is free from the door assembly.
8. Lift up the door assembly to release the upper and lower door hinge pins from the upper and lower oven hinges.
9. Now, the door assembly is free.

NOTE: When the individual parts are replaced, refer to "Door Disassembly".

Door Assembly Re-install

1. On re-installing door, insert the lower oven hinge to lower door hinge pin.
2. Insert the upper oven hinge to the upper door hinge pin.
3. Shut the door (close the contacts of interlock switches).
4. Make sure upper and lower oven hinges are inserted into the upper and lower door hinge pins.
5. Make sure the door is parallel with oven face lines (left and upper side lines) and door latch heads pass through latch holes correctly.
6. Re-install the door stopper to the door assembly.
7. Re-install the hood louver to the oven cavity front face plate with the three (3) screws.

NOTE: After any service to the door:

- (A) Make sure that stop switch primary interlock switch, secondary interlock switch and monitor switch are operating properly. (Refer to chapter "Test Procedures".)
- (B) An approved microwave survey meter should be used to assure compliance with proper microwave radiation emission limitation standards.

After any servicing, make sure of the following :

1. Door latch heads smoothly catch latch hook through latch holes and that latch head goes through center of latch hole.
2. Deviation of door alignment from horizontal line of cavity face plate is to be less than 1.0mm.
3. Door is positioned with its face pressed toward cavity face plate.
4. Re-install outer case and check for microwave leakage around door with an approved microwave survey meter. (Refer to Microwave Measurement Procedure.)

NOTE: The door on a microwave oven is designed to act as an electronic seal preventing the leakage of microwave energy from oven cavity during cook cycle. This function does not require that the door be air-tight, moisture (condensation)-tight or light-tight. Therefore, occasional appearance of moisture, light or sensing of gentle warm air movement around oven door is not abnormal and do not of themselves indicate a leakage of microwave energy from oven cavity.

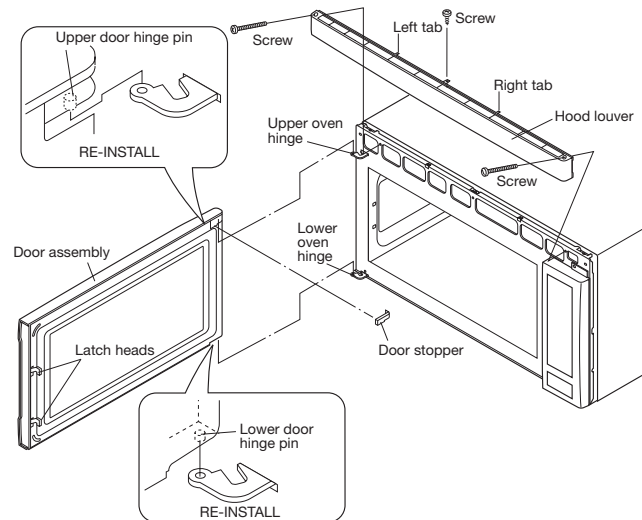

Figure C-2. Door Replacement and Adjustment

Section 5

Wiring Diagrams

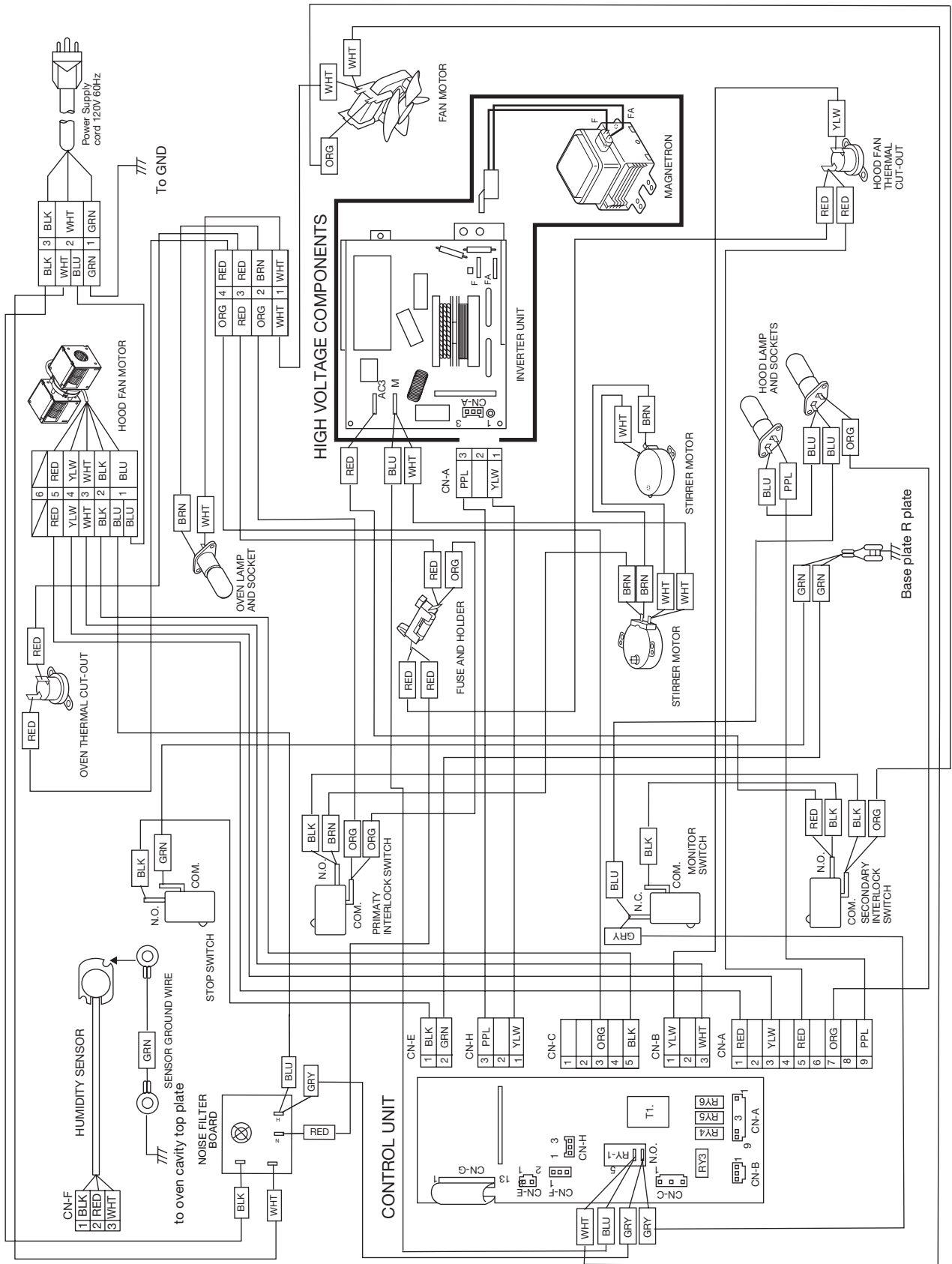

Figure S-1. Pictorial Diagram

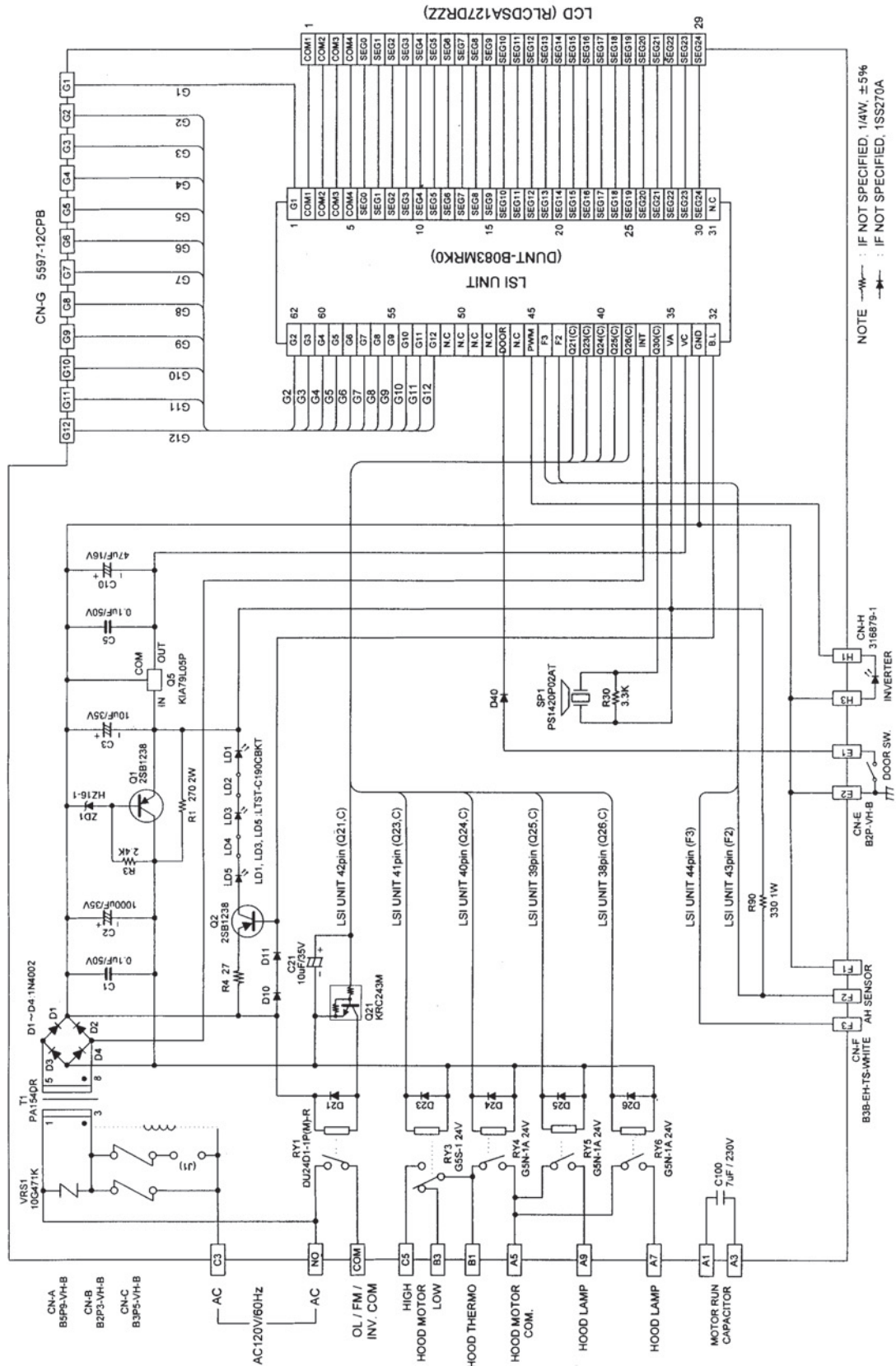

Figure S-2b. Power Unit Circuit

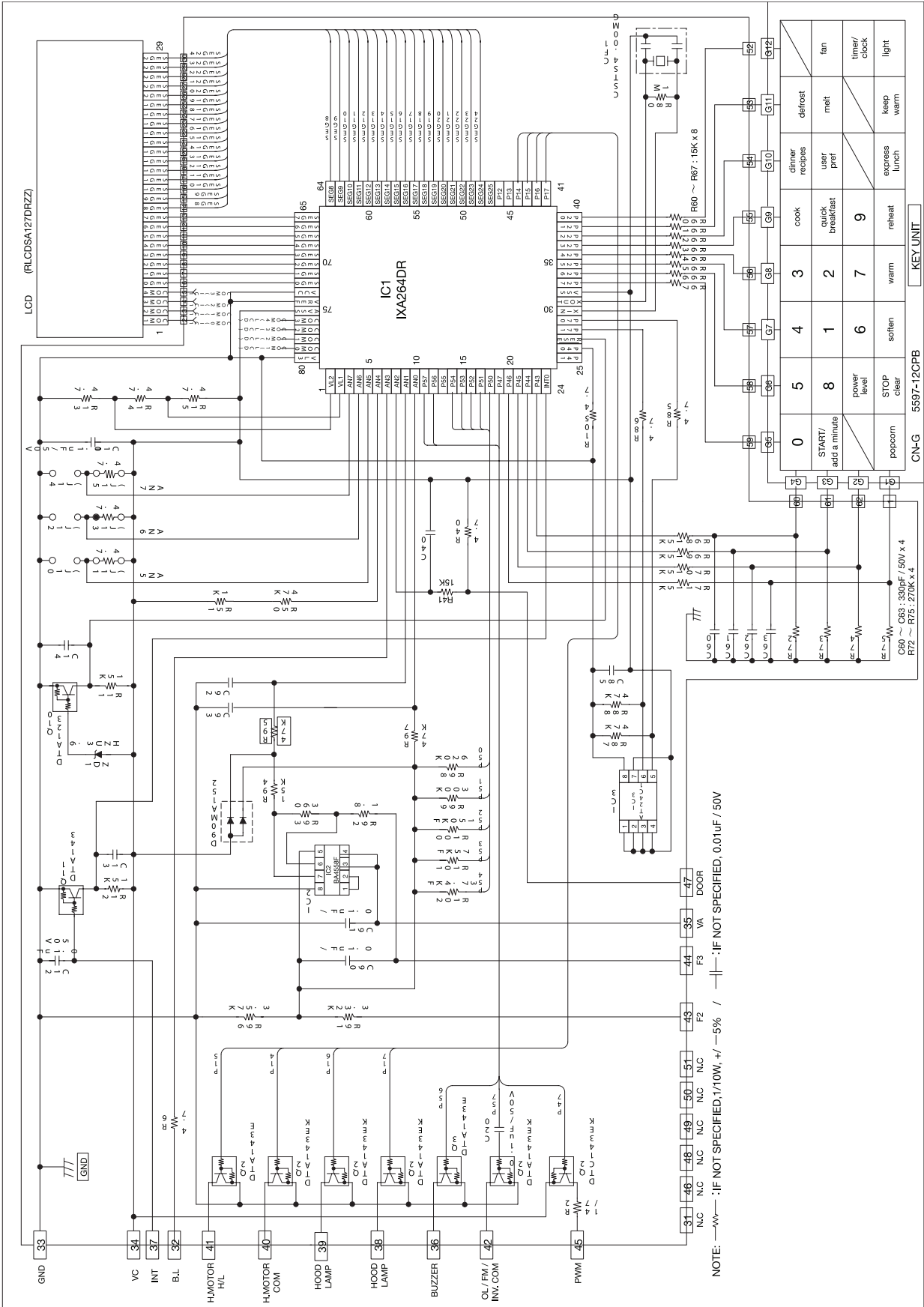

Figure S-3b. LSI Unit Circuit

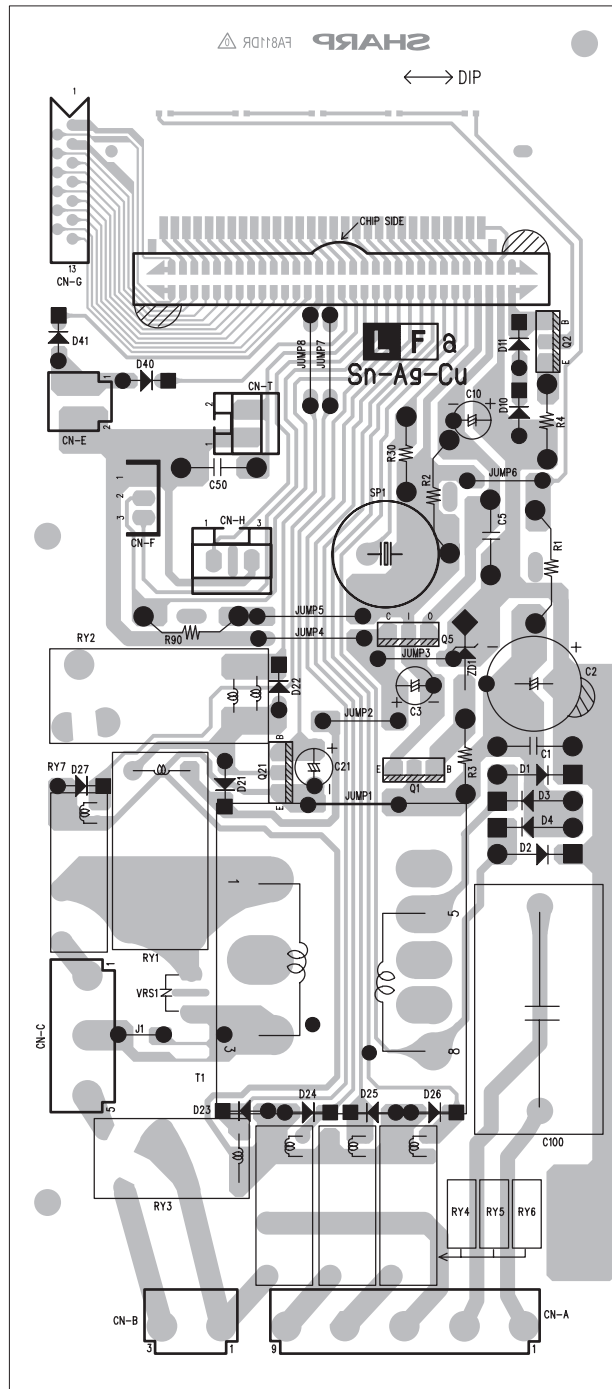

Figure S-4. Printed Wiring Board

Section 6

Parts List

Note: The parts marked " Δ" may cause undue microwave exposure.
 The parts marked "*" are used in voltage more than 250V.

REF. NO.		DESCRIPTION	Q'TY
ELECTRIC PARTS			
* Δ*	1	Inverter unit	1
	2	Magnetron	1
	3	Power supply cord	1
	4	Stirrer motor	2
	5	Thermal cut-out (Oven) Open at 145 °C	1
	6	Thermal cut-out (Hood fan) N.O. Close at 60C Open at 45 °C	1
	7	Lamp socket	3
	8	Oven lamp and hood lamps	3
	9	Fuse holder	1
	10	Primary interlock/ Secondary interlock/ stop switches	3
	11	Monitor switch (V-16G-2C25) with fuse (20A) assembly	1
	12	Hood fan motor	1
	13	Fan motor	1
	14	Humidity sensor	1
	15	Noise filter	1
CABINET PARTS			
	16	Rear stay	1
	17	Hood louver	1
	18	Base plate R	1
	19	Deflector	1
	20	Outer case cabinet	1
	21	Schematic diagram	1
	22	Hood lamp glass assembly	1
	23	Base cover	1
CONTROL PANEL PARTS			
	24	Control unit	1
	25	Screw; 3mm x 8mm	3
	26	Key fixing angle	1
	27	Control panel frame assy	1
	28	Open button assy	1
	29	Button spring	1
OVEN PARTS			
	30	Door stopper	1
	31	Chassis support	2
	32	Table tray assembly	1
	33	Stirrer fan assembly	2
	34	Magnetron duct	1
	35	Open lever	1
	36	Oven cavity (Not replaceable part)	1
	37	Shield spring	1
	38	Latch hook	1
	39	Unit mounting plate assembly	1
	40	Fan blade	1
	41	Cord bushing	1
	42	Part no longer used	2
	43	Hood intake duct R	1

REF. NO.		DESCRIPTION	Q'TY
44		Hood lamp mount	1
45		Part no longer used	2
46		Distribution plate assembly	1
47		Hood duct R	1
48		Hood duct L	1
49		Fan duct	1
50		Orifice	1
51		Left stirrer shaft	1
52		Stirrer motor gear	1
53		Motor mounting angle	1
54		Stirrer shaft assembly	1
55		Rack holder front	4
56		Left rear rack holder	2
57		Right rear rack holder	2
58		Center duct	1
59		Oven lamp angle	1
60		Lamp filter	1
61		Unit angle	1

DOOR PARTS

62		Door assembly	1
63		Sealer film	1
64		Latch head	1
65		Latch spring	1
66		Choke cover	1
67		Screw : 4mm x 8mm	4

MISCELLANEOUS

68		Installation material assembly	1
69		Grommet	1
70		Toggle screw	4
71		Screw : 5mm x 60mm	2
72		Screw : 4mm x 12mm	8
73		Screw : 5mm x 35mm	6
74		Washer	2
75		Rack	1
76		Operation manual	1
77		Top and Wall template	1
78		Oven lamp harness	1
79		High voltage wire assembly	1
80		Stop/ PWM wire harness	1
81		DHHS service caution label	2
82		Monitor caution label	1
83		DHHS/GRD/CAUTION label	1
84		Charcoal filter	1
85		Grease filter	2
86		Exhaust damper assembly	1
87		Sensor ground wire	1
88		Part no longer used	2
89		Main wire harness	1
90		NHW caution	1
91		Harness ferrite	1
92		Harness ferrite	1
93		Installation instructions	1

SCREWS,NUTS AND WASHERS

94		Screw : 5mm x 8mm	4
95		Screw : 4mm x 12mm	41
96		Screw : 4mm x 8mm	4
97		Special screw	2
98		Special screw	2
99		Screw : 3mm x 8mm	9

Oven Parts

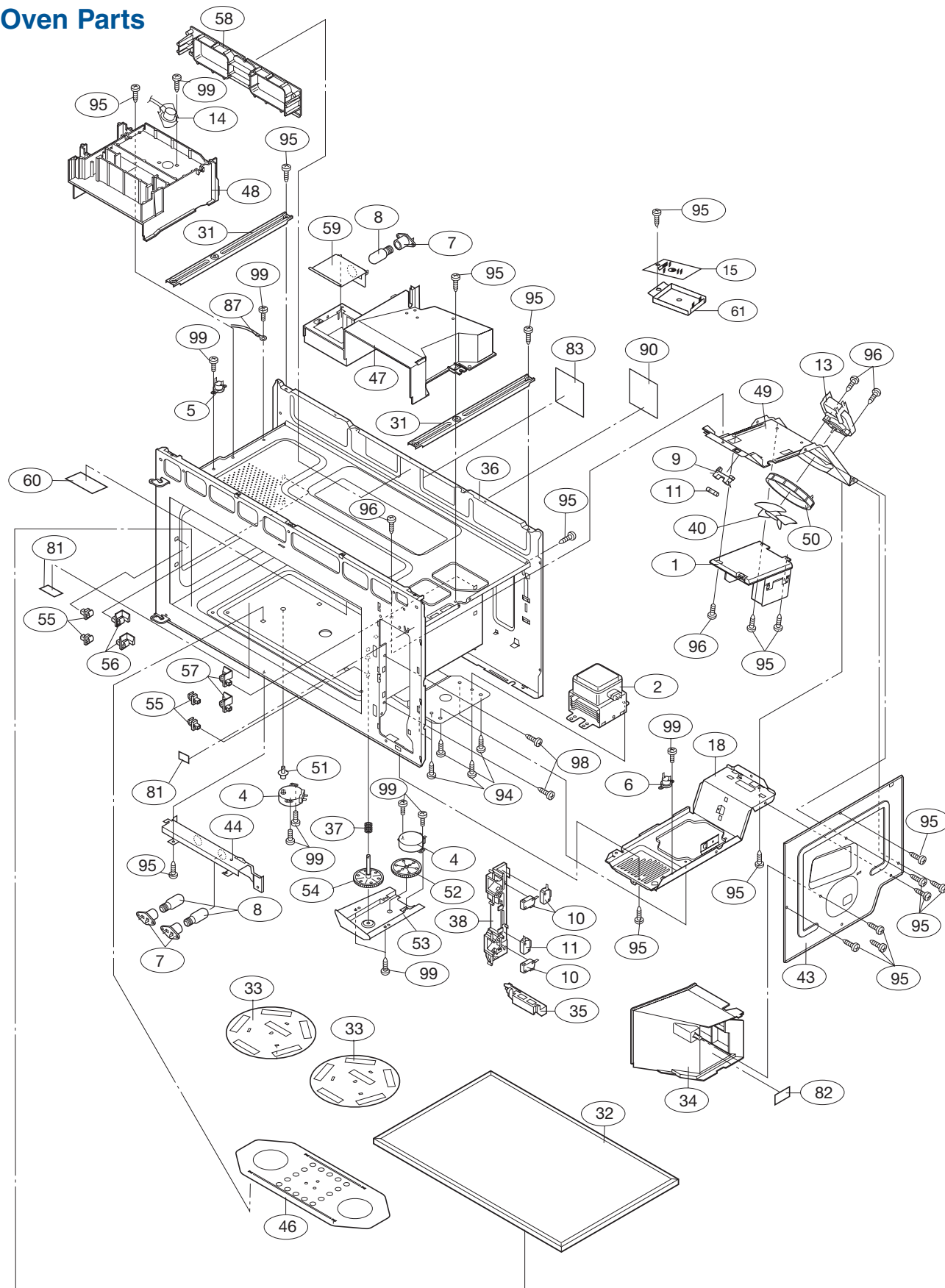

Cabinet Parts

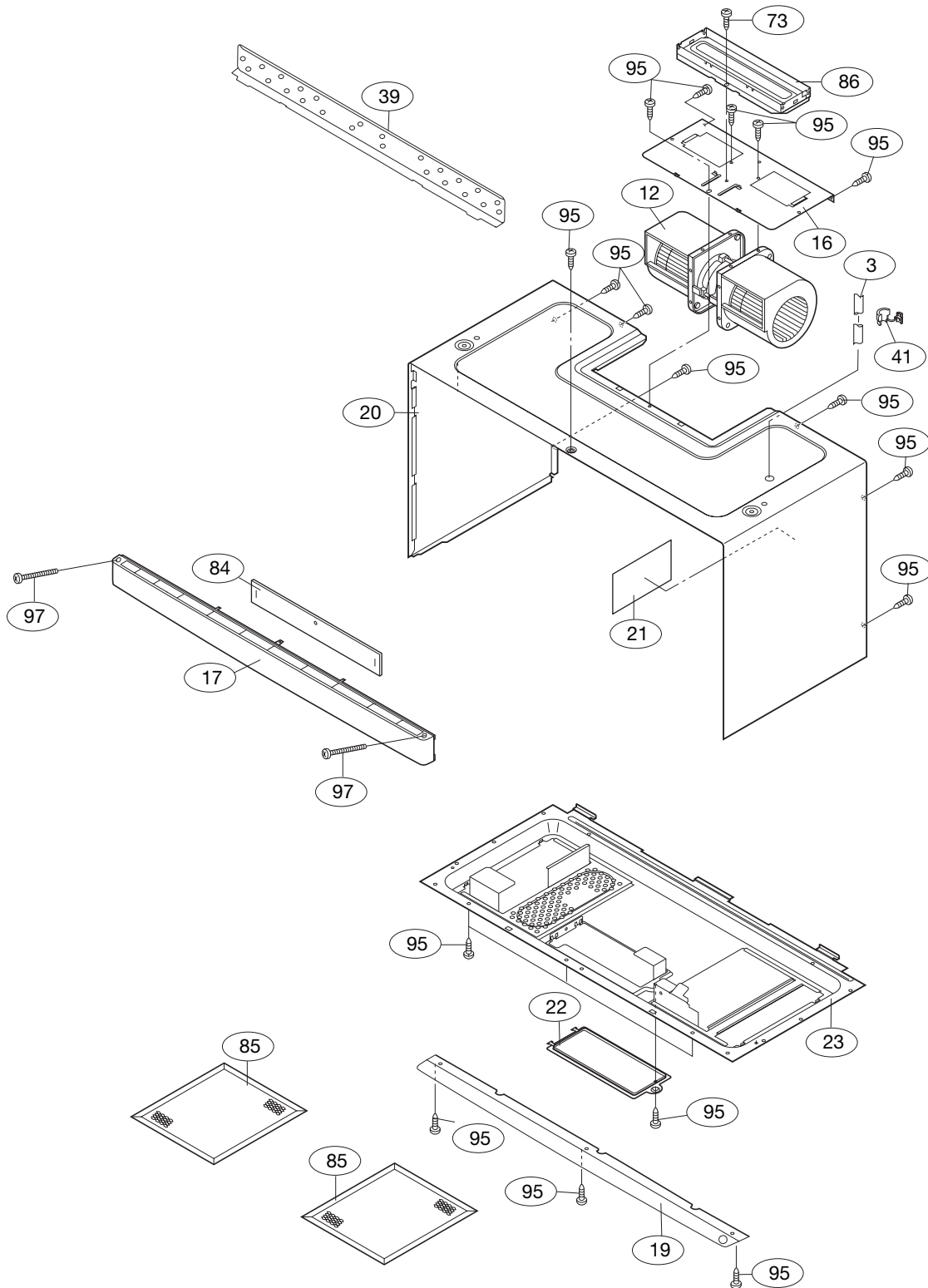

Door Parts

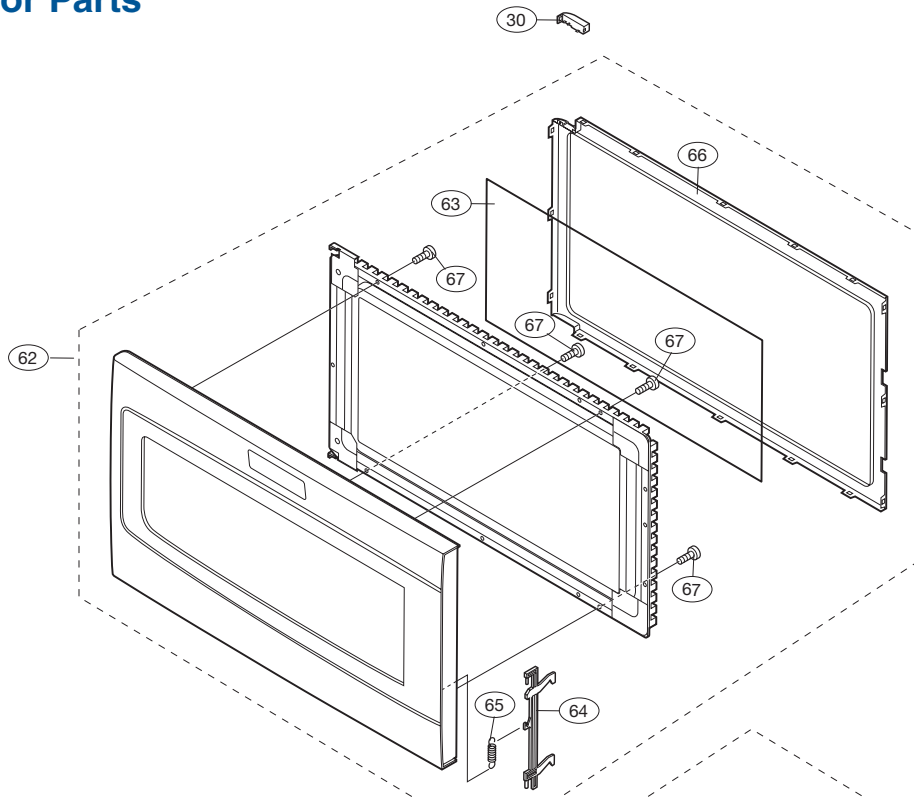

CONTROL PANEL PARTS

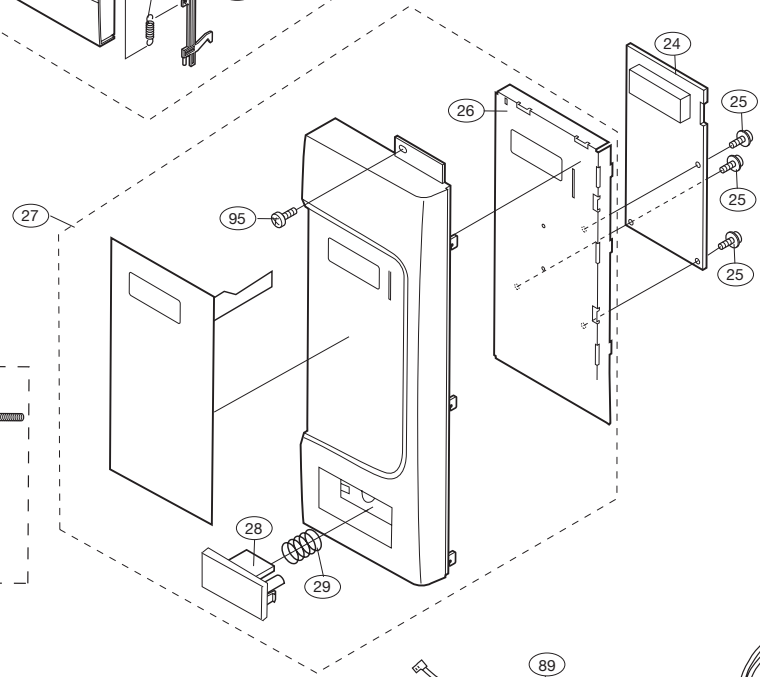

MISCELLANEOUS

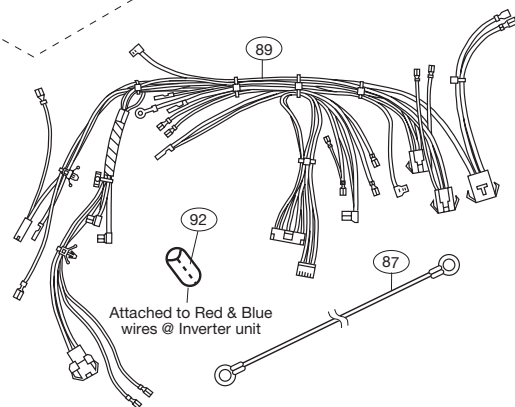
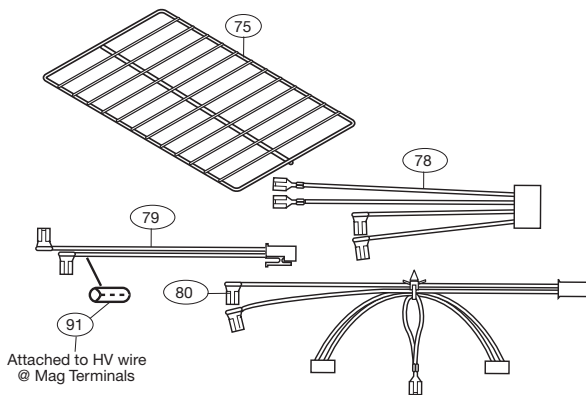
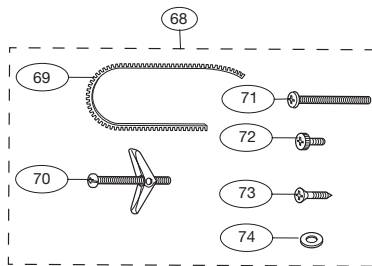

Packing and Accessories

