



# TECHNICAL SERVICE GUIDE

## GE & HOTPOINT "1993" Electric Ranges (30" Free-Standing)

### GE Models

JBS02 S1    JBP20GS1  
JBS03GS1    JBP22 S1  
JBS12GS1    JBP23GS1  
JBS16GS1    JBP25GS1  
JBS17GS1    JBP45GS1  
JBS26 S1    JBP45WS1  
JBP19GS1    JBP48GS1  
JBP21GS1    JBP56GS1  
JBP22GES1  
JBP24GS1  
JBP26GS1  
JBP45AS1  
JBP46GS1  
JBP55GS1  
JBP58GS1  
JBS03 S1  
JBS06GS1  
JBS16 S1  
JBC17GS1  
JBS18GS1  
JBS27GS1

### HOTPOINT Models

RB524 S1  
RB525 S1  
RB525GS1  
RB526 S1  
RB532GS1  
RB536 S1  
RB632GS1  
RB633 S1  
RB636 S1

# G. E. & HOTPOINT

## 1993 ELECTRIC RANGE (30" FREE-STANDING)

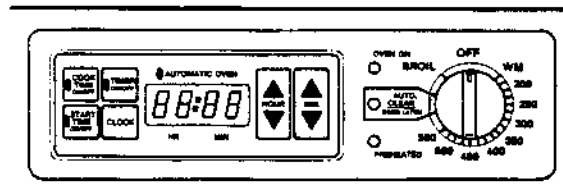

**QUICK SET - 3**

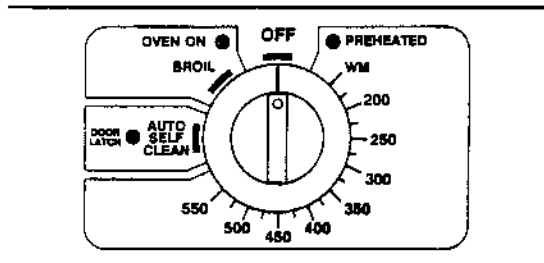

**QUICK SET - 1**

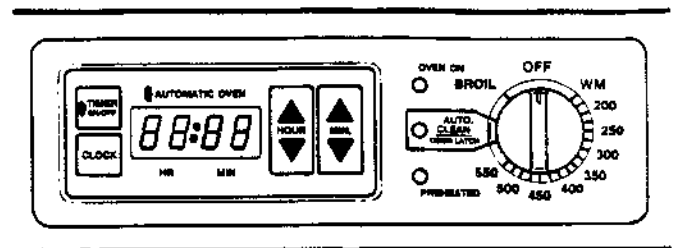

**QUICK SET - 2**

**QUICK SET - 1, 2 & 3  
ELECTRONIC CONTROLS**

**&**

**NEW FULL GLASS DOORS**

# 1993 GE & HOTPOINT 30" FREE-STANDING ELECTRIC RANGES

The new 1993 GE & Hotpoint 30" Free-Standing Electric consist of a 3 New Quick Set Self-Clean Controls and a redesigned Door Assembly.

MODEL NO.	OVEN CONTROL SYSTEM & CIRCUIT TYPE CLOCK / TIMER	KILOWATT RATING	OVEN DOOR TYPE	SURFACE UNITS (PLUG-IN)	
<b>GE MODELS-STANDARD OVENS WITH FIXED COOKTOPS</b>					
JBS02 S1	<u>SINGLE LINE BREAK</u>	DUAL RATED  (240V) 9.8KW  (208) 7.4KW	PAINTED / SOLID	1 - 8" UNIT & 3 - 6" UNITS WITH CHROME DRIP PANS	
JBS03 S1	<u>THERMOSTAT</u>		PAINTED / SOLID		
JBS03GS1	<u>NO CLOCK / TIMER</u>		BK GLASS / SOLID		
JBS06GS1			WH GLASS / SOLID		
JBS12GS1			BG GLASS / SOLID		
JBS16 S1	<u>THERMOSTAT</u>		(208) 7.4KW		PAINTED / WINDOW
JBS16GS1	<u>CLOCK W / MIN. TIMER</u>				BK GLASS/ WINDOW
<b>HPT MODELS-STD &amp; CONTIN CLEAN WITH FIXED COOKTOP</b>					
RB524 S1	<u>SINGLE LINE BREAK</u>	DUAL RATED  (240V) 9.8KW  (208) 7.4KW	PAINTED / SOLID	1 - 8" UNIT & 3 - 6" UNITS WITH CHROME DRIP PANS	
RB525 S1	<u>THERMOSTAT</u>		PAINTED / SOLID		
RB525GS1	<u>NO CLOCK / TIMER</u>		BK GLASS / SOLID		
RB526 S1			PAINTED / SOLID		
RB532GS1			BK GLASS / SOLID		
RB632GS1	<u>THERMOSTAT</u>		(208) 7.4KW		BK GLASS / SOLID
RB633GS1	<u>CLOCK W / MIN. TIMER</u>				WH GLASS / SOLID
<b>GE MODELS- STD &amp; CONTIN CLEAN WITH LIFT UP COOKTOP</b>					
JBS17GS1	<u>SINGLE LINE BREAK</u>	DUAL RATED	BK GLASS/WINDOW	2 - 8" UNITS & 2 - 6" UNITS WITH CHROME DRIP PANS	
JBC17GS1	<u>THERMOSTAT</u>	(240V) 10.8KW	BK GLASS/WINDOW		
JBS18GS1	<u>CLOCK W / MIN. TIMER</u>	(208) 8.1KW	WH GLASS WINDOW		
JBS26 S1	<b>DLB - SELECTOR SW. / T'STAT, CLOCK/OVEN CONTROL</b>	DUAL RATED (240V) 11.7KW (208V) 8.5KW	PAINTED / WINDOW		
JBS27GS1	<u>SINGLE LINE BREAK</u> <u>THERMOSTAT</u> <u>CLOCK W / MIN. TIMER</u>	DUAL RATED (240V) 10.8KW (208) 8.1KW	WH GLASS/WINDOW	2 - 8" UNITS & 2 - 6" UNITS WITH PORCEL. DRIP PANS	
<b>HPT MODELS- STD &amp; CONTIN CLEAN WITH LIFT UP COOKTOP</b>					
RB536 S1	<b>DLB - SELECTOR SW. / T'STAT, CLOCK/OVEN CONTROL</b>	DUAL RATED (240V) 11.7KW (208V) 8.5KW	PAINTED/ WINDOW	2 - 8" UNITS & 2 - 6" UNITS WITH CHROME DRIP PANS	
RB636 S1			PAINTED/ WINDOW		

MODEL NO.	OVEN CONTROL SYSTEM & CIRCUIT TYPE CLOCK / TIMER	KW ATT RATING	OVEN DOOR TYPE	SURFACE UNITS (PLUG-IN)
<b>GE MODELS-SELF CLEAN OVENS WITH FIXED COOKTOPS</b>				
JBP19G S1	<b><u>SINGLE LINE BREAK QUICK-SET-1 CONTROL</u></b>	DUAL RATED  (240V) 10.8KW  (208) 8.1KW	BK GLASS / SOLID	1 - 8" UNIT & 3 - 6" UNITS WITH CHROME DRIP PANS
JBP20G S1	<b><u>SINGLE LINE BREAK QUICK-SET-1 CONTROL WITH CLOCK/TIMER</u></b>		BK GLASS / SOLID	
JBP22 S1	<b>DLB - SELECTOR SW. / T'STAT, CLOCK/OVEN CONTROL</b>		PAINTED / SOLID	
JBP22GES1	<b><u>SINGLE LINE BREAK QUICK-SET-3 CONTROL</u></b>		BK GLASS/SOLID	
<b>GE MODELS-SELF CLEAN OVENS WITH LIFT UP COOKTOP</b>				
JBP21G S1	<b><u>SINGLE LINE BREAK QUICK-SET-2 CONTROL</u></b>	DUAL RATED  (240V) 10.8KW  (208) 8.1KW	BK GLASS/SOLID	2 - 8" UNITS & 2 - 6" UNITS WITH PORCELAIN DRIP PANS
JBP23G S1	<b>DLB - SELECTOR SW. / T'STAT, CLOCK/OVEN CONTROL</b>		WH GLASS/SOLID	
JBP24G S1	<b><u>SINGLE LINE BREAK QUICK SET - 3 CONTROL</u></b>		BK GLASS/SOLID	
JBP25G S1			WH GLASS/SOLID	
JBP26G S1			BK GLASS/WINDOW	
JBP45G S1			BG LARGE/WINDOW	
JBP45A S1			AG LARGE/WINDOW	
JBP45W S1			WG LARGE/WINDOW	
JBP46G S1			WG LARGE/WINDOW	
JBP48G S1			BG LARGE/WINDOW	
JBP55G S1			<b><u>ERCII CONTROL</u></b>	
JBP56G S1		WG LARGE/WINDOW		
JBP58G S1		BG LARGE/WINDOW		

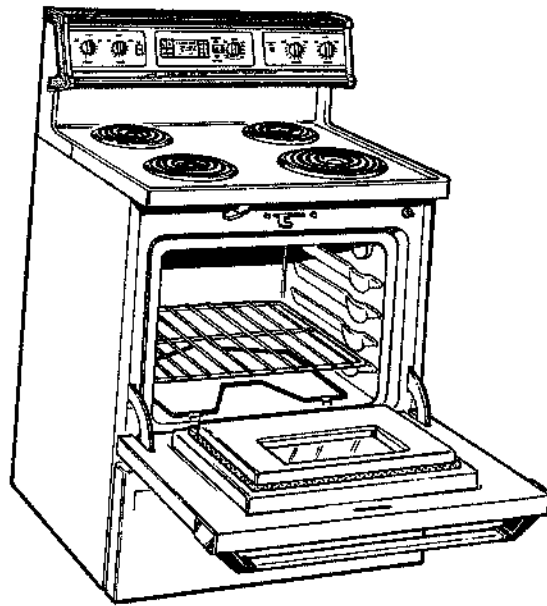

QUICK SET - 3

- J BP22GES1
- J BP24G S1
- J BP25G S1
- J BP26G S1
- J BP45G S1
- J BP45A S1
- J BP45W S1
- J BP46G S1
- J BP48G S1

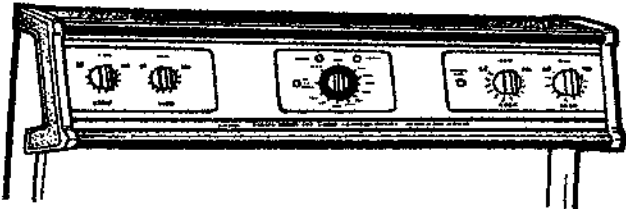

QUICK SET - 1

J BP19G S1

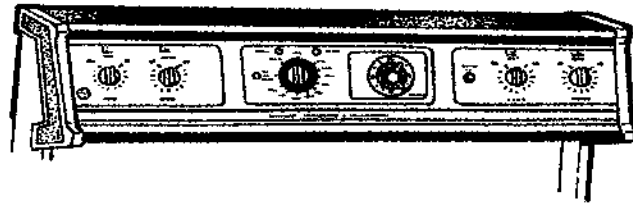

QUICK SET - 1 WITH ANALOG - 1  
CLOCK/TIMER

J BP20G S1



QUICK SET - 2

J BP21G S1

**RATING PLATE:**

The Rating Plate is located on the Panel Filler behind the storage drawer or kick panel.

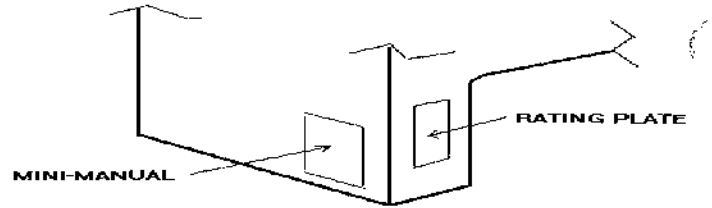

**MINI-MANUAL / SCHEMATIC WIRING DIAGRAM:**

The Mini-Manual is located in the drawer area either on the left or right side of lower body.

**CONTROL SYSTEMS**

Three new Range Control Systems have been developed for the GE 30" Electric Free Standing Self Clean Ranges. The controls are referred to as QUICK SET 1, 2, & 3 by Marketing and T08 Versions "A", "B" & "C" (or VA Controls) by Engineering. The basic Electronic Control and Sensor system replace the Analog-3 Clock/Timer, Selector Switch, Thermostat and Thermal Limit Switch. Oven functions can be selected by rotating the knob to the desired Bake Temperature or Broil Setting.

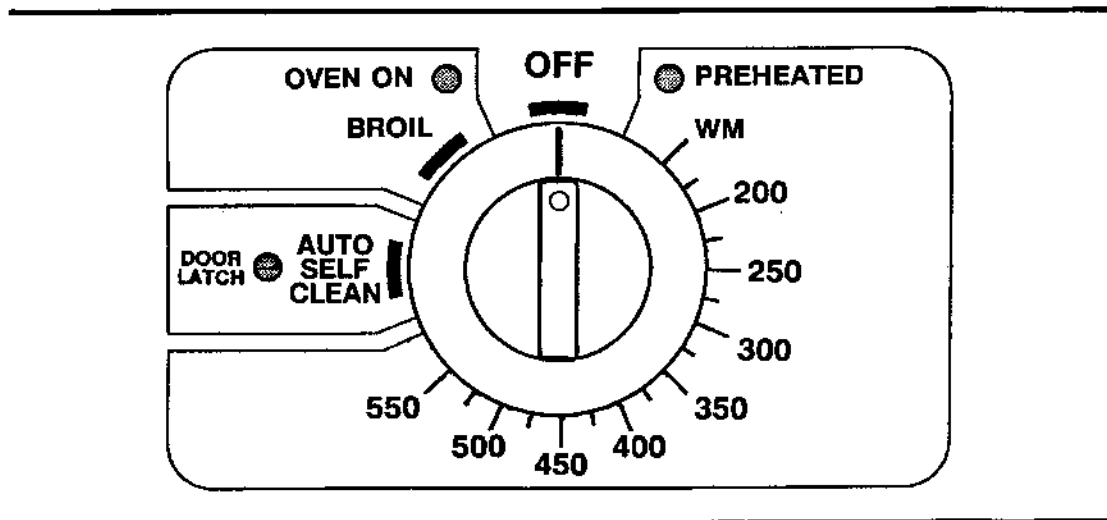

**QS-1 or Version "A"**

Oven control only, consists of a Selector Knob for choosing Bake, Broil or Clean modes (does not contain time of day clock or timer).

30" ELECTRIC FREE-STANDING

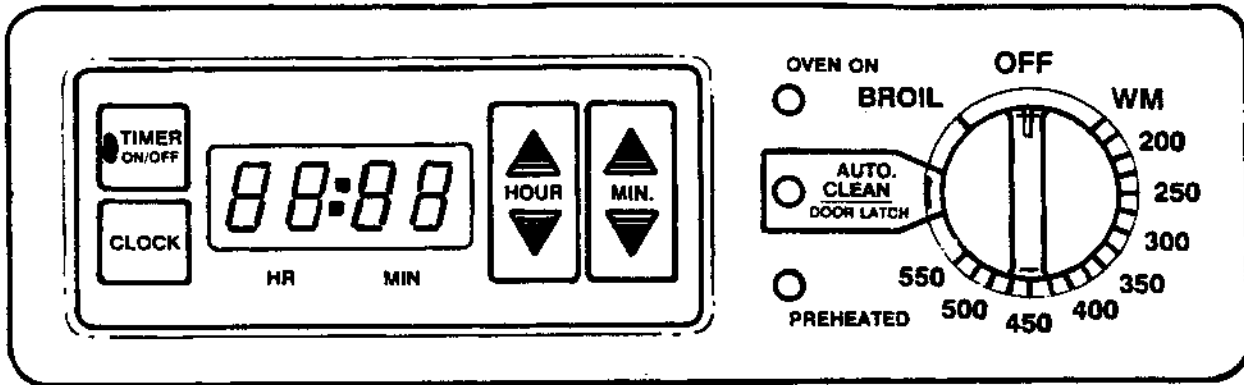

QS-2 or Version "B"

Oven control system consists of a Selector Knob for choosing Bake, Broil or Clean modes and electronic time of day clock and timer (No oven control timing functions).

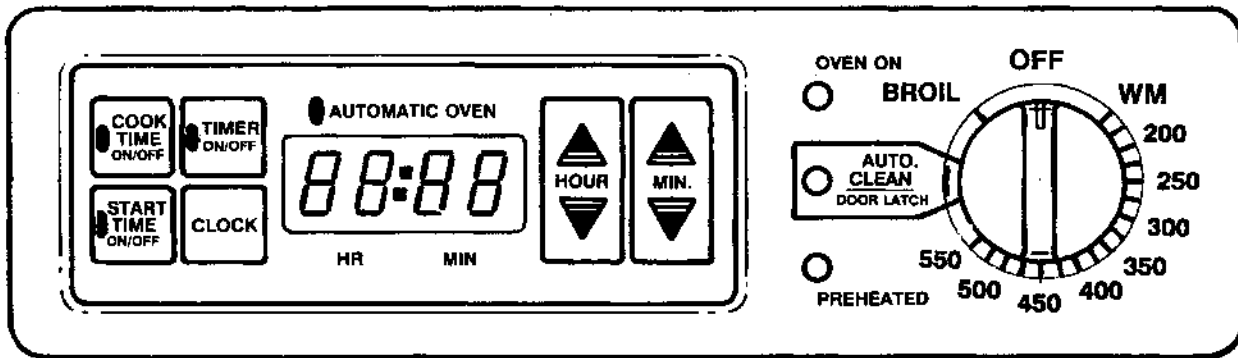

QS-3 or Version "C"

Complete oven control system including automatic oven timed functions (time bake, delay start & stop). Control consists of a Selector Knob for choosing Bake, Broil or Clean modes a electronic clock and timer along with Cook Time and Start Time Pads.

30" ELECTRIC FREE-STANDING

**CONTROL OPERATION:**

The oven heating is controlled by a function knob. The knob has a 360° rotation with détentes at the clean, broil and at the lowest and highest bake settings. If the knob is set in the dead spaces between détentes the oven will not operate.

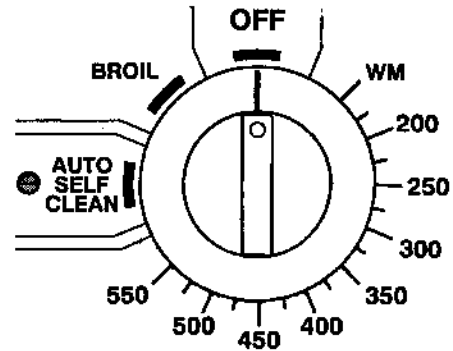

**POWER UP OR AFTER POWER FAILURE:**

**Quick Set - 1**

Control does not have a display thus eliminating any visual indication of power up or power failure except when the Select Knob is in any position except "OFF". The "ON" LED would light in those cases.

**QUICK SET - 2 & 3**

Display will flash "PF" until the clock is set or a heating function is selected. When a heating function is selected before setting the clock the display will blank out. When display blanks out press the clock pad and set the time of day.

**INCREASE / DECREASE PADS:**  
**QUICK SET - 2 & 3**

Each control has two Increase / Decrease Pads to aide in the selection of time in hours and minutes.

- Hour Pad used for selecting time in one hour intervals.
- Minute Pad for selecting time in minutes.

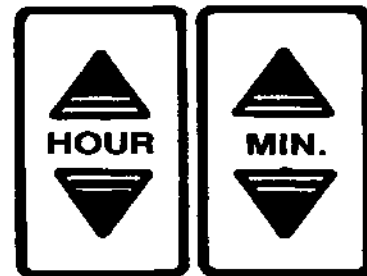

**TO SET CLOCK:**  
**QUICK SET - 2 & 3**

- Touch Clock Pad
- Touch Hour pad to Select Time in hours
- Press minute Pad to select correct time of day.
- Touch Clock Pad

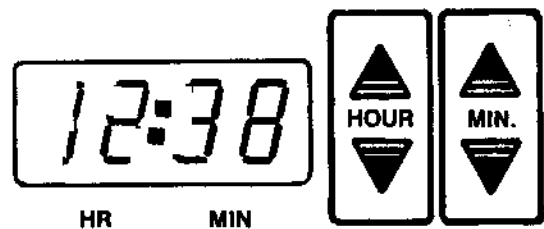



## BAKE OPERATION QUICK SET - 1, 2 & 3

**To Bake:**

1. Rotate Select Knob to desired temperature setting.
2. " ON " light comes on and the unit begins its sequence cycle.
3. After oven reaches selected temperature the Preheat Light will come on and remain on for the balance of the Bake Operation.

**NOTE:** Quick Set - 2 & 3 Controls will also give six (6) short beeps when pre-selected temperature is reached.

During the BAKE OPERATION both the Bake & Broil heating elements are used. The control cycles relays to supply power to either the bake or broil unit. Both units can never be on at the same time.

### SEQUENCE CYCLE

Each complete sequence cycle is 111 seconds, Bake Unit "ON" 90 seconds followed by Broil Unit "ON" 19 seconds with a 1 second delay between switching from one unit to the other.

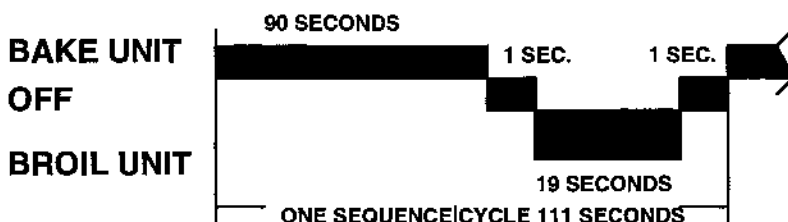

**NOTE:** Sequence cycle starts during the preheat phase and continues throughout the bake mode of operation.

- When the oven has reached its pre-selected temperature and cycles "OFF", the next heat cycle will start where the previous cycle left off.  
Example - Oven cycles "OFF" 45 seconds into the sequence cycle (bake unit), when the oven calls for heat the bake unit will come on for 45 seconds and then switch to the broil unit.

### BAKE OPERATION

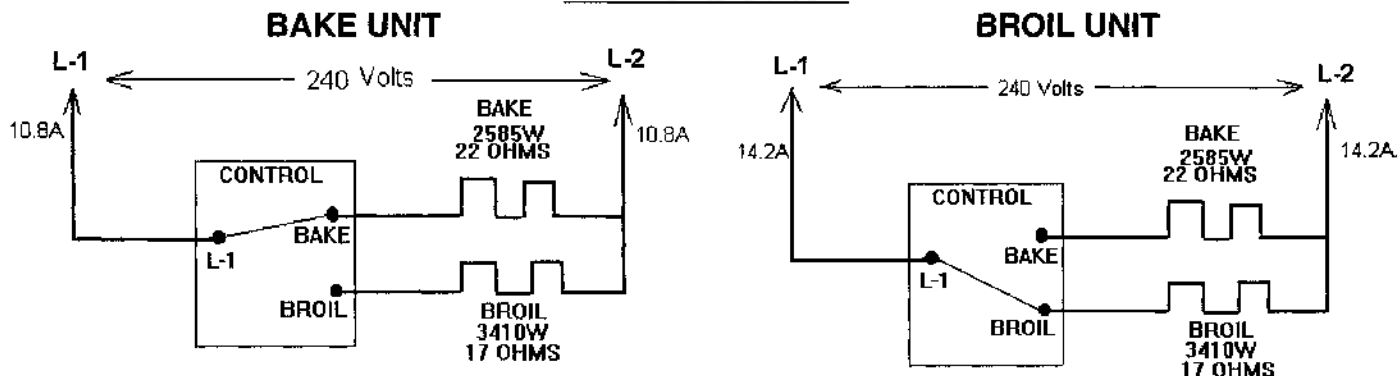

### BROIL OPERATION QUICK SET - 1, 2 & 3

#### To Broil:

1. Open Oven Door to Broil Stop.
2. Rotate Knob to Broil détente.
3. "ON" light comes on until oven is turned "OFF".

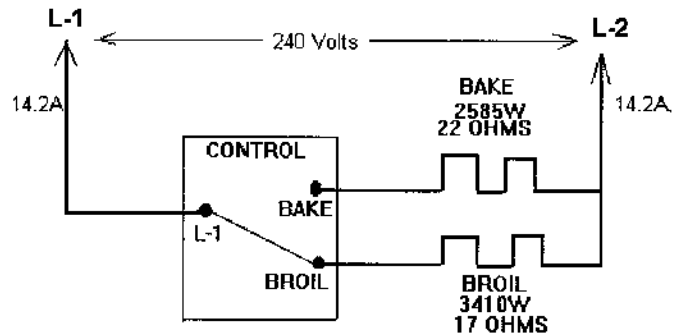

### CLEAN OPERATION QUICK SET - 1 & 2

1. Move latch handle as far to the right as it will go.



2. Rotate Knob to the Clean détente.

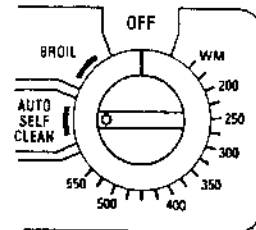

3. Door Latched Light and "ON" Light comes on.

The Clean Time is preset for a total of 4 hours and 20 minutes which includes a 50 minute cool down. (The Clean Time is Automatically set for 4hrs. and 20 mins. and can not be changed). Both the "ON" Light and Door Latched Light will stay on for the complete 4 hours and 20 minutes. At the conclusion of the Clean Cycle the latch and on lights will flash until the Select Knob is set to the off position and door is unlatched. The control will not let the bake or broil modes operate if the door is latched (latch light will flash).

### SEQUENCE CYCLE

During the initial heat up period the Broil Unit only is used until the oven reaches approximately 700° F. then it will begin a similar sequence cycle pattern as the bake mode. Each complete sequence cycle is 107 seconds, Bake Unit "ON" 90 seconds followed by Broil Unit "ON" 15 seconds with a 1 second delay between switching from one unit to the other.

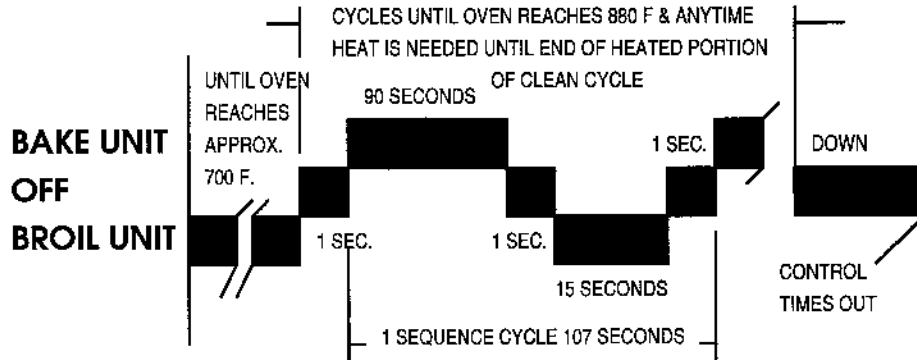

When the oven has reached its clean temperature and cycles "OFF", the next heat cycle will start where the previous cycle left off.

#### BAKE UNIT OPERATION

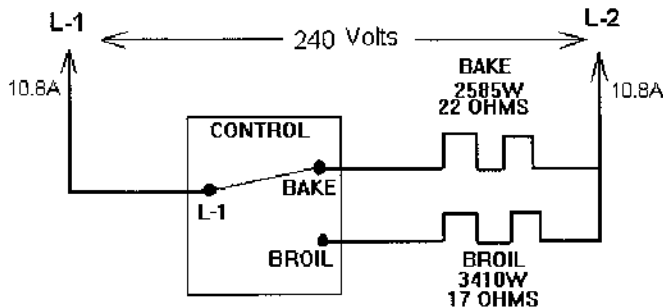

#### BROIL UNIT OPERATION

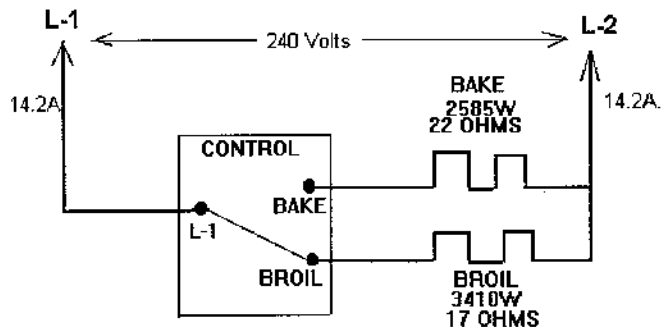

### QUICK SET- 3

Quick Set - 3 Control operates the same as Quick Set - 1 & 2 except clean time can be changed and the control can be programmed for a delayed start time.

#### Clean Operation:

1. Latch Door and rotate Knob to Clean Position.
2. Display shows 4 Hrs. & 20 Mins. and Door Latched and Oven On lights are "ON".
3. Display then counts down to zero.

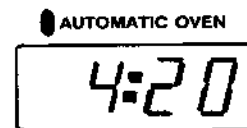

30" ELECTRIC FREE-STANDING (CLEAN OPERATION CONTINUED)

**NOTE:**

Clean time can be varied between 3 Hrs. and 5 Hrs. & 59 Mins. by using the HOUR or MINUTE Increase / Decrease Pads.

When the Clean Cycle has timed out the DOOR LATCHED & Oven ON lights will flash until the Select Knob is turned to "OFF" position.

**COOK TIME & START TIME (Quick Set - 3 Only)**

These Pads are used for either Time Bake or Delay Start for Clean.

1. Press Start Time pad and then use Hour and Minute pads to select when oven is to start.
2. Press Cook Time if you want control length of the cooking operation.



OVEN CONTROL CALIBRATION:

**QUICK SET - 1 Bake Temperature Adjustment:**

1. Turn Select Knob to "OFF" and remove.
2. The oven temperature can be increase or decrease 20° by pressing and holding either the button by the +20° or -20°. The following lights will flash when the temperature change has been recognized:
  - **Preheat Light** - Oven Adjusted 20°F Hotter than Normal.
  - **Door Latch Light** - Oven Adjusted 20°F Cooler than Normal.
  - **Oven On Light** - Factory Setting (Nominal).
  - When the button is released the light will stop flashing and the new temperature is set.

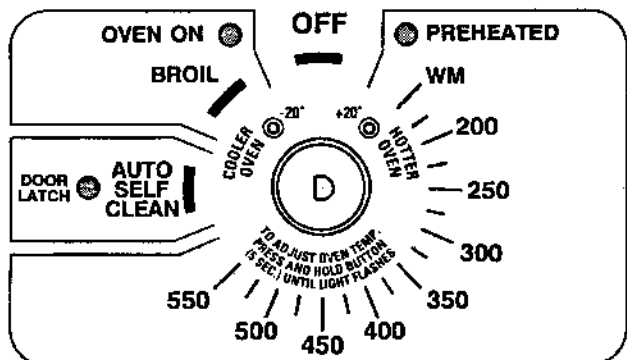

**NOTE:**





To determine if the oven temperature has been increase or decreased, Press and Hold the opposite adjustment button from the direction you wish to adjust oven temperature and observe which light comes on.

Example: You want to increase oven temperature - Press the Cooler Oven Button. If Door Latch Light comes on the temperature has not been previously changed. If the Oven On Light comes on the oven temperature has been previously increased.

**QUICK SET - 2 & 3 Bake Temperature Adjustment:**

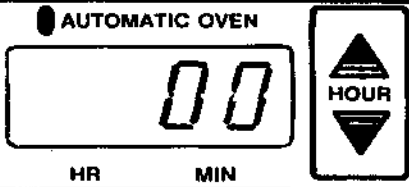
The Bake Temperature can be adjusted by  $\pm 35^{\circ}\text{F}$  in  $5^{\circ}$  increments.

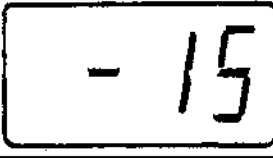
To Adjust Oven Bake Temperature:

<p>1. Press and hold both the <b>INCREASE</b> and <b>DECREASE HOUR</b> Pads for about 4 seconds. Display will change from time of day to show 00.</p>	
<p>2. Raise or lower oven temperature by using the Hour Increase/Decrease Pads.</p>	
<p>3. Using the up HOUR Pad arrow will increase temperature in <math>5^{\circ}</math> increments up to <math>35^{\circ}</math>. The display will show the temperature without a + sign.</p>	
<p>4. Using the down HOUR Pad arrow will decrease temperature in <math>5^{\circ}</math> increments up to <math>35^{\circ}</math>. The temperature will be displayed with a - sign in front of the number.</p>	
<p>5. Approx. 5 seconds after temperature is changed the display will return to time of day and oven is ready for use.</p>	

**DÉTENTE - SPRING & CAM**

Each control contains a Spring and Cam mounted to the shaft of the rotary switch on the control. Their purpose is to provide a positive to the control as it is rotated from one mode of operation to another. **The spring and cam do not come with replacement controls.**

To Remove Cam & Spring:

1. Rotate knob to warm position and pull knob off.
2. Gentle pull cam off shaft.
3. Remove spring mounting nut and lift spring off.

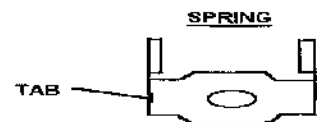
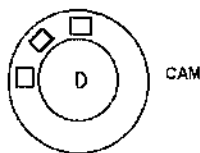

**NOTE:** The control will function without the cam & spring.

**QUICK SET 1, 2 & 3 CONTROL SYSTEM**

The back of the Quick Set Controls contain 2 relays, control transformer, sensor connector, latch switch connector and four terminals (L-1, N, Bake & Broil). The smart board is physically larger on QS-1 & 2 because of the display.

**QUICK SET-1**

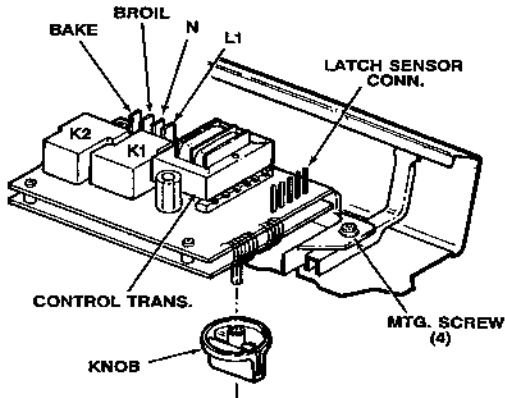

**QUICK SET 2 & 3**

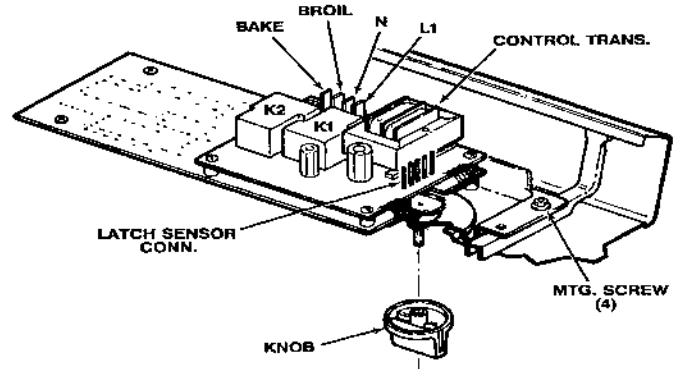

**CONTROL VOLTAGES:**

NOTE: All Quick Set Controls have **Single Line Break**.

The following voltages must be present on the control board with the Select Knob in the "OFF" position.

TERMINALS	VOLTAGE
L-1 to N	120 volts (all the time) control transformer
L-1 to BAKE	240 volts (Knob in "OFF" position)
L-1 to BROIL	240 volts (Knob in "OFF" position)

**Static Tape:** On the face of the control running from the shaft of the switch over to the mounting flange is a piece of metal tape. The purpose of the tape is to ground the shaft of the control to guard against static discharge which can damage the circuit boards.

**SENSOR & LOCK CIRCUIT**

SENSOR CIRCUIT	TO CHECK SENSOR CIRCUIT:
The Sensor Circuit consists of: <ul style="list-style-type: none"> <li>• Sensor</li> <li>• Sensor Wiring and Connector</li> </ul>	1. Disconnect Power to Range and unplug sensor. 2. Measure resistance of Sensor - $15\Omega$ at $75^{\circ}$ F. room temperature. (Voltage at terminals on control measures 5.0 VDC.)

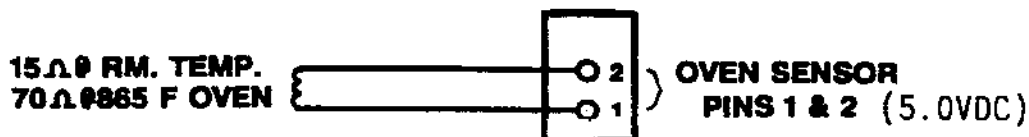

### FLASHING LIGHT CODES

LIGHT	MEANING
<b>Preheat Light Flashing</b> - with control knob in any position except "OFF"	Shorted / open Sensor or Sensor Circuit Shorted to range frame.
<b>Door Latch Light Flashing</b>	<ul style="list-style-type: none"> <li>Control set to cooking mode with door locked</li> <li>Control set to clean with door unlocked.</li> </ul>
<b>Oven On and Door Latch Light Flashing</b>	The clean cycle has timed out and Select Knob has not been turned to "OFF" and door unlatched.

### DOOR LATCH MECHANISM

The Latch Mechanism is thermally operated. When the latch handle is moved to the clean position the latch hook engages into a slot in the oven door.

As the clean cycle progresses the increasing oven temperature causes the bi-metal coil on the latch mechanism to expand. This expansion causes a cam to rotate into the path of the latch mechanism thus locking it into position.

The door locks up when the oven has reached a temperature of between 560° and 600° F and will remain locked until the oven has dropped to around 520° F.

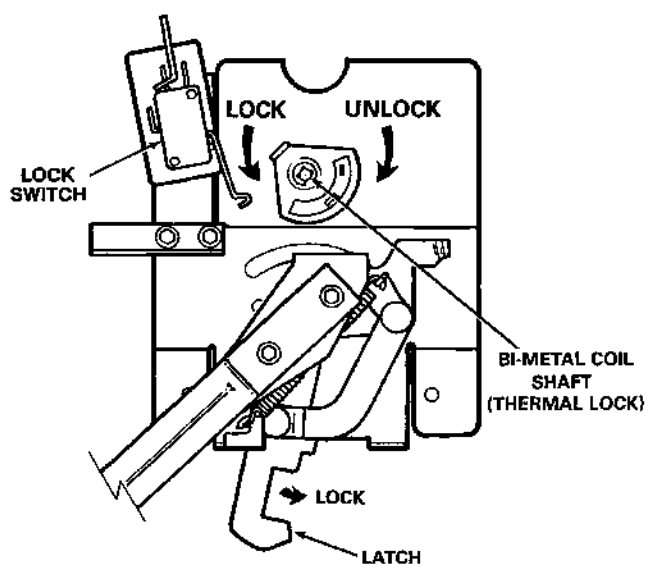

**NOTE:** The door can be unlocked by manually rotating the Latch Arm Stop on the back of the latch in the unlock direction as shown in the above illustration and moving the latch handle to the unlock position.

**NOTE:** When installing new latch make sure that the Latch Arm Stop is Rotated Fully to the Unlocked Position.

### DOOR LOCK CIRCUIT

The Lock Switch is located on the back left of the Latch Mechanism. The switch connects to Pins 1 & 3 on the control board.

Ohm Meter Test

Door Unlatched Pins 1 & 3  $\infty \Omega$ .

Door Latched Pins 1 & 3  $0 \Omega$ .

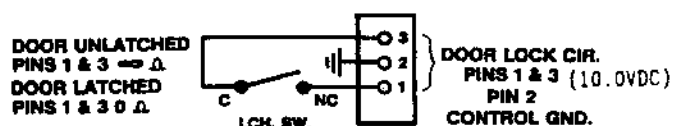

## OVEN DOORS

The 30" Free-Standing Electric Range Full Glass Door has been redesigned with the primary changes being in the area of the Door Handle, Handle End Caps, Vent Trim and Door Trim. The oven door consists of two major subassemblies; Outer Panel Assembly and Inner Panel and Liner Assembly. The unique feature about the new door is the strength of the door handle assemble. The Door Assembly can be separated into its two subassemblies by removing four (4) screws at the bottom flange and the two (2) handle screws.

### STANDARD / CONTINUOUS CLEAN FULL GLASS DOORS TWO TYPES

#### FULL GLASS SOLID DOOR

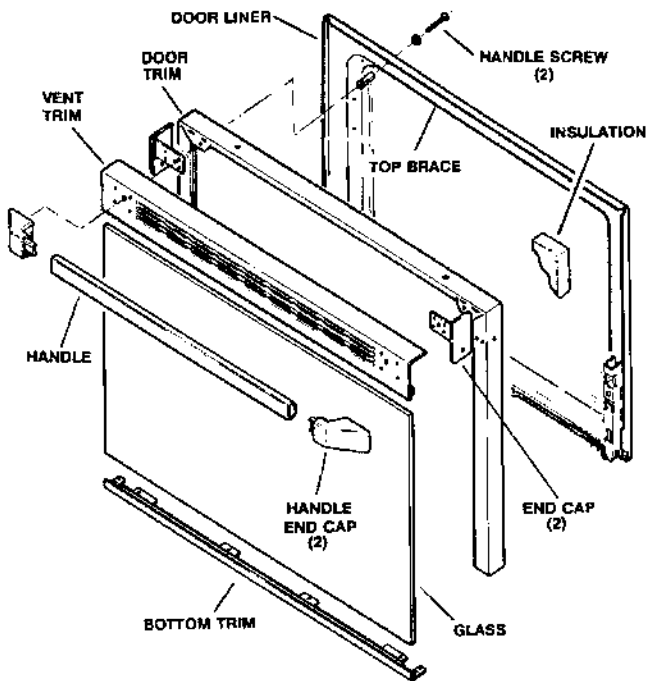

#### FULL GLASS WINDOW DOOR

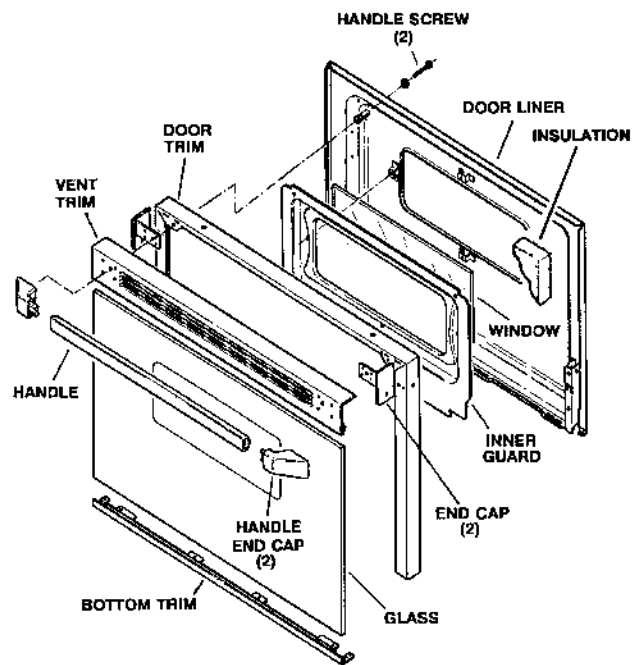

### GLASS REPLACEMENT

Remove eight (8) screws from bottom trim and slide glass out.

### HANDLE, END CAP & VENT TRIM REPLACEMENT

1. To remove handle - remove 2 screws (1 from each side) mounting handle end caps.
2. To remove vent trim - (4 screws) 2 securing vent trim to door trim and 2 mounting side end caps.

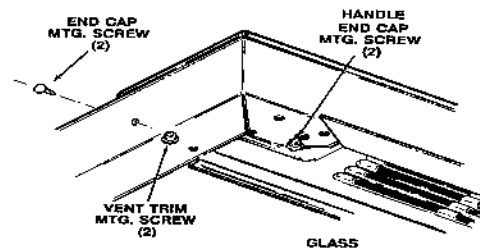



## SELF CLEAN FULL GLASS DOOR TWO TYPES

### FULL GLASS SOLID DOOR

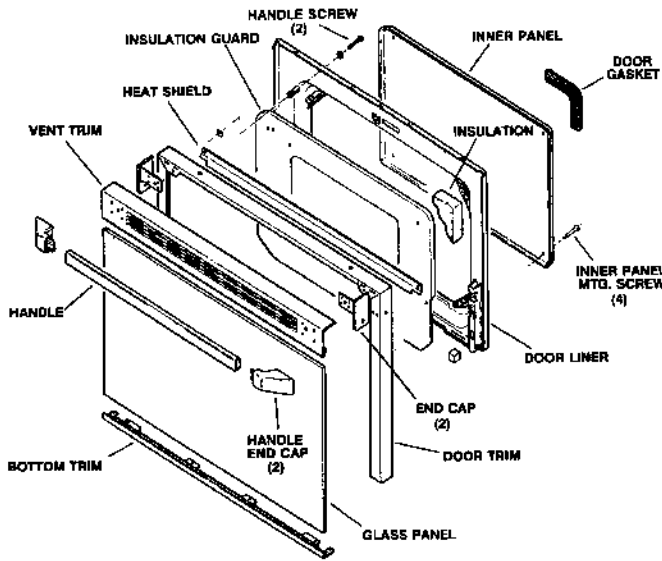

### FULL GLASS WINDOW DOOR

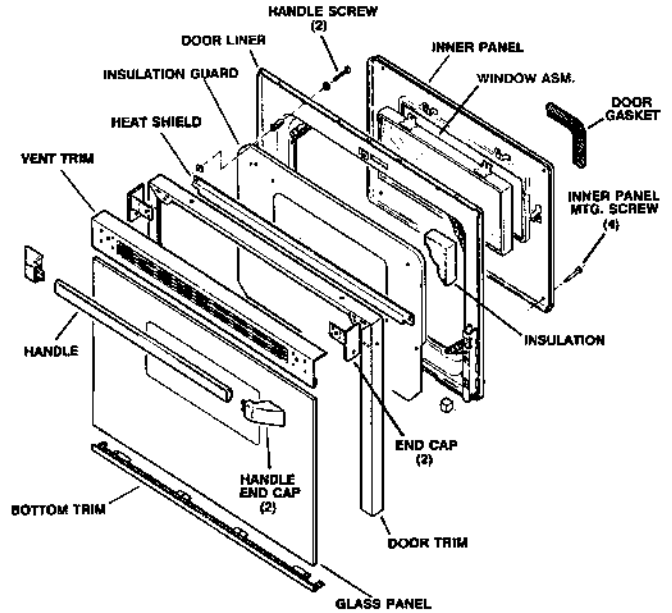

**NOTE:** Doors with Large Viewing Window also contain a piece of reflective foil across the top inside of the glass.

### GLASS REPLACEMENT

Remove eight (8) screws from bottom trim and slide glass out.

### HANDLE, END CAP & VENT TRIM REPLACEMENT

1. To remove handle - remove 2 screws (1 from each side) mounting handle end caps.
2. To remove vent trim - (4 screws) 2 securing vent trim to door trim and 2 mounting side end caps.

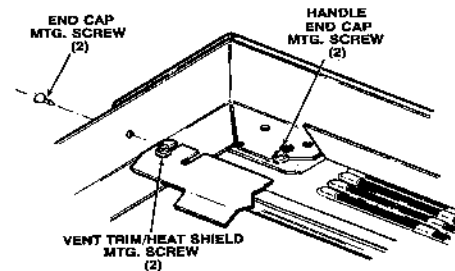

**MINI-MANUAL / SCHEMATIC WIRING DIAGRAM INDEX**

MODEL NO.	PUB NO.	SHEET NO.	PAGE NO.
J BS16 S1, J BS16G S1, J BS17G S1, JBC17G S1, J BS18G S1, JBS27G S1	31-1423	617	17
J BS02 S1, J BS03 S1, J BS03G S1, JBC06G S1, R B524 S1, R B525 S1, R B525G S1, R B526 S1	31-1424	618	18
J BS26 S1	31-1425	619	19
R B536 S1	31-1426	620	20
J BP55G S1, JBP56W S1, JBP58G S1	31-1427	621	21
J BP19 S1, J BP21G S1, J BP22GES1, J BP24G S1, J BP25G S1, J BP26G S1, J BP45G S1, J BP45A S1, J BP45W S1, J BP46G S1, J BP48G S1	31-1428	622	22
J BS12 G S1, R B532G S1, R B632G S1	31-1429	623	23
J BP22 S1, J BP23G S1	31-1430	624	24
J BP20G S1	31-1442	625	25

# SCHEMATIC DIAGRAM

DWG. NO. 164D8656P001

## WARNING

POWER MUST BE DISCONNECTED  
BEFORE SERVICING THIS APPLIANCE

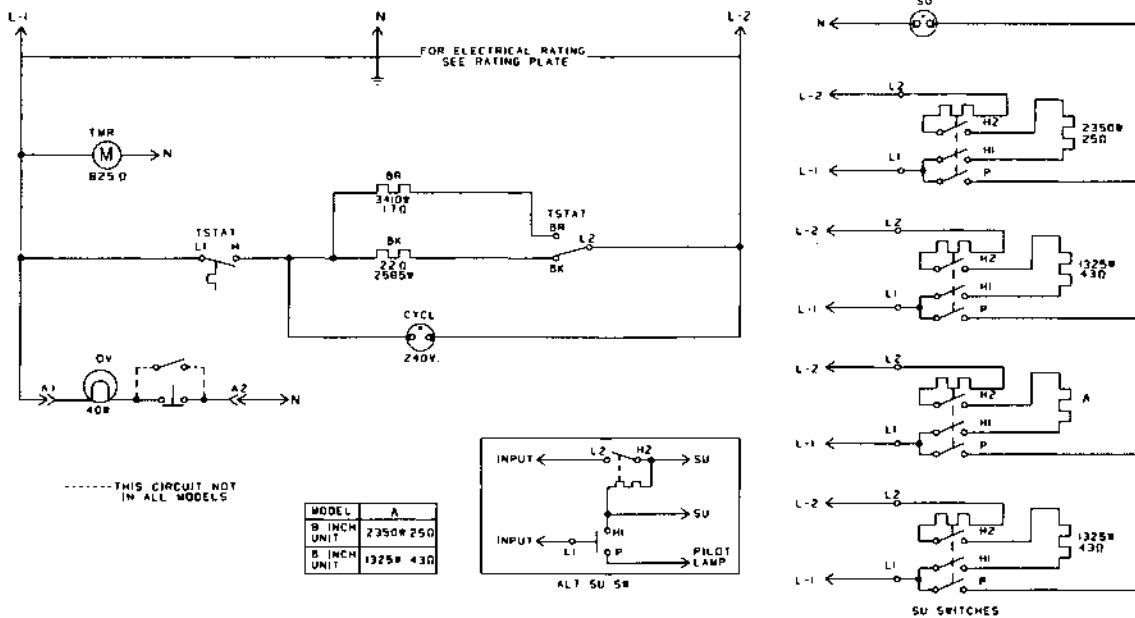

# WIRING DIAGRAM

164D8001 SH 19

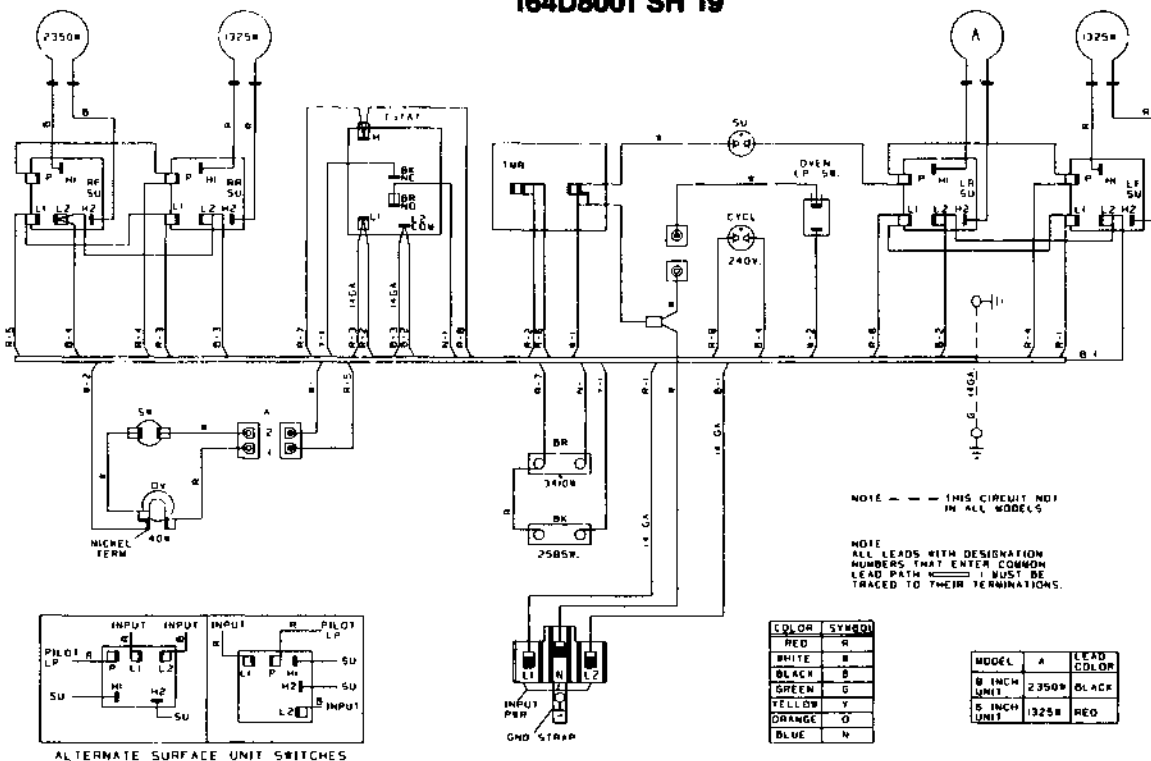

NOTE: FOR SERVICE REPLACEMENT USE 16 GA. 150°C WIRE EXCEPT AS INDIVIDUALLY NOTED ON LEADS. ALL 150°C WIRE COLOR DESIGNATED BY HASH MARK.

# SCHEMATIC DIAGRAM

DWG. NO. 164D8641P001

**WARNING**  
**POWER MUST BE DISCONNECTED**  
**BEFORE SERVICING THIS APPLIANCE**

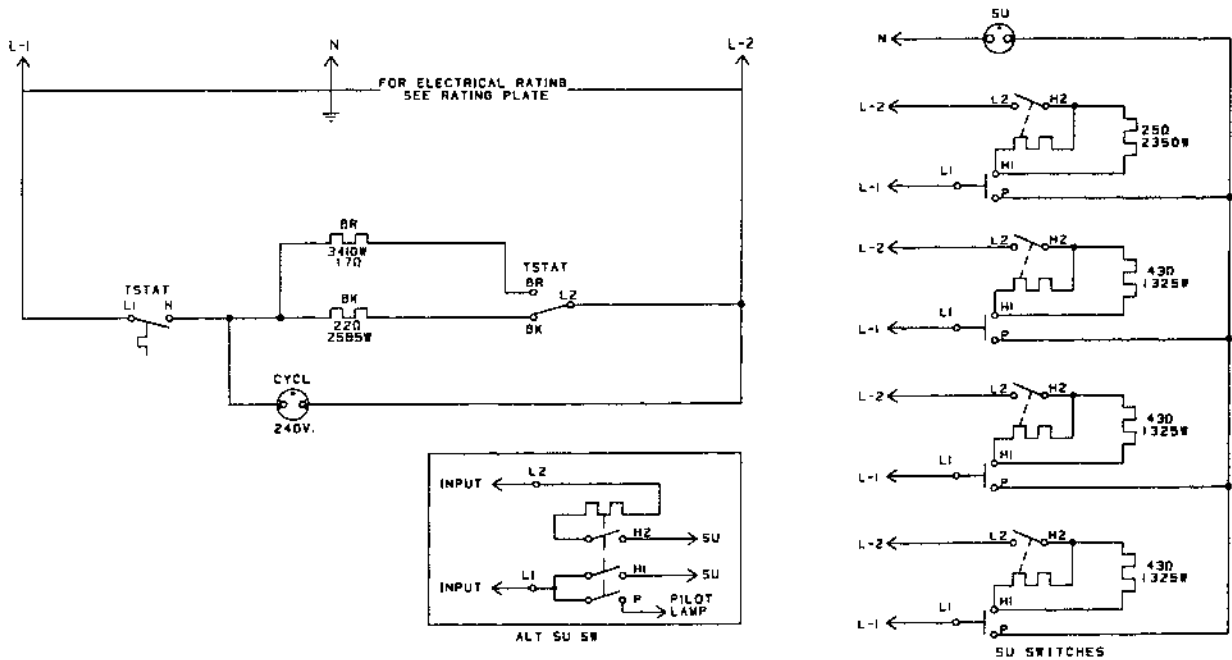

# WIRING DIAGRAM

164D8001 SH 16

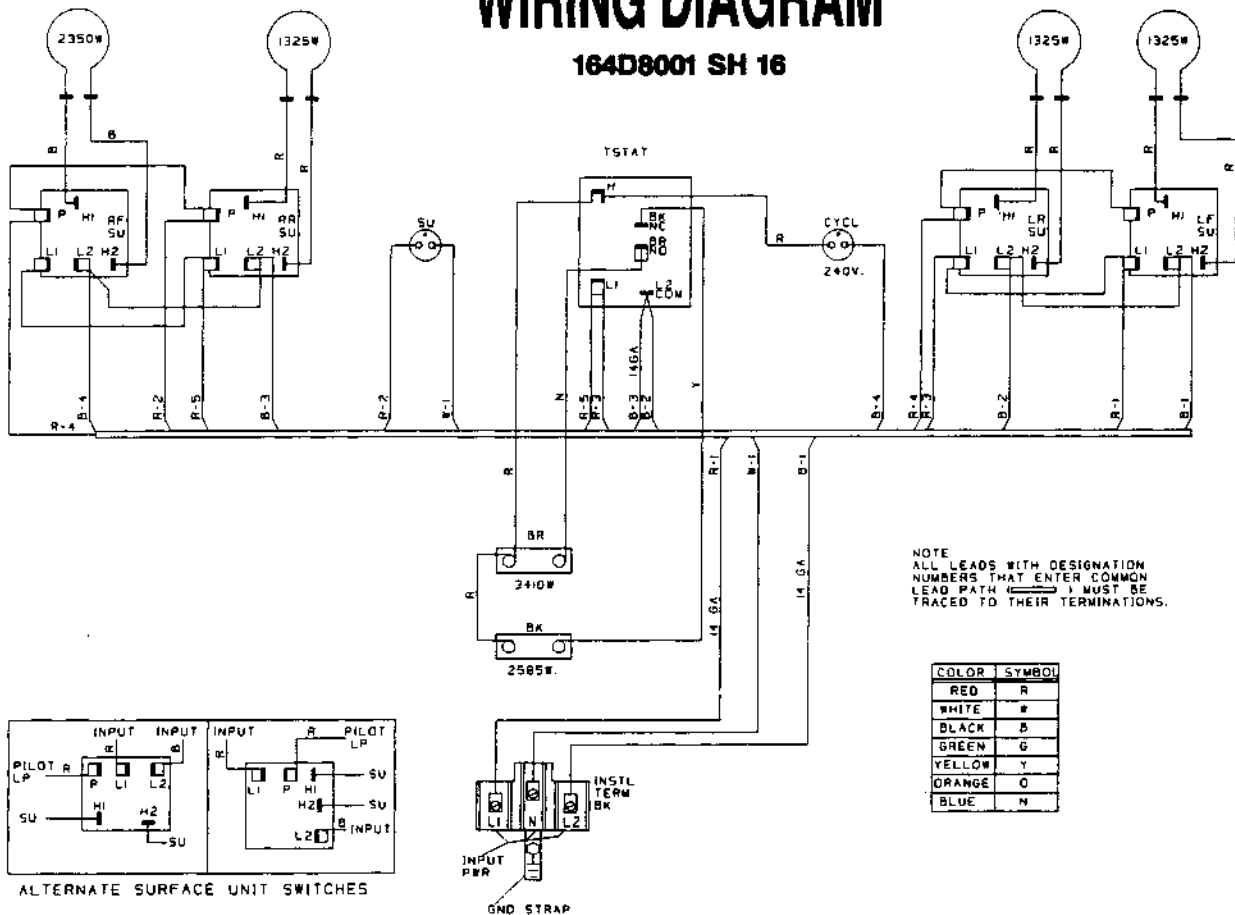

**NOTE: FOR SERVICE REPLACEMENT USE 16 GA. 150°C WIRE EXCEPT AS INDIVIDUALLY NOTED ON LEADS. ALL 150°C WIRE COLOR DESIGNATED BY HASH MARK.**

# SCHEMATIC DIAGRAM

DWG. NO. 164D8657P001

**WARNING**  
POWER MUST BE DISCONNECTED  
BEFORE SERVICING THIS APPLIANCE

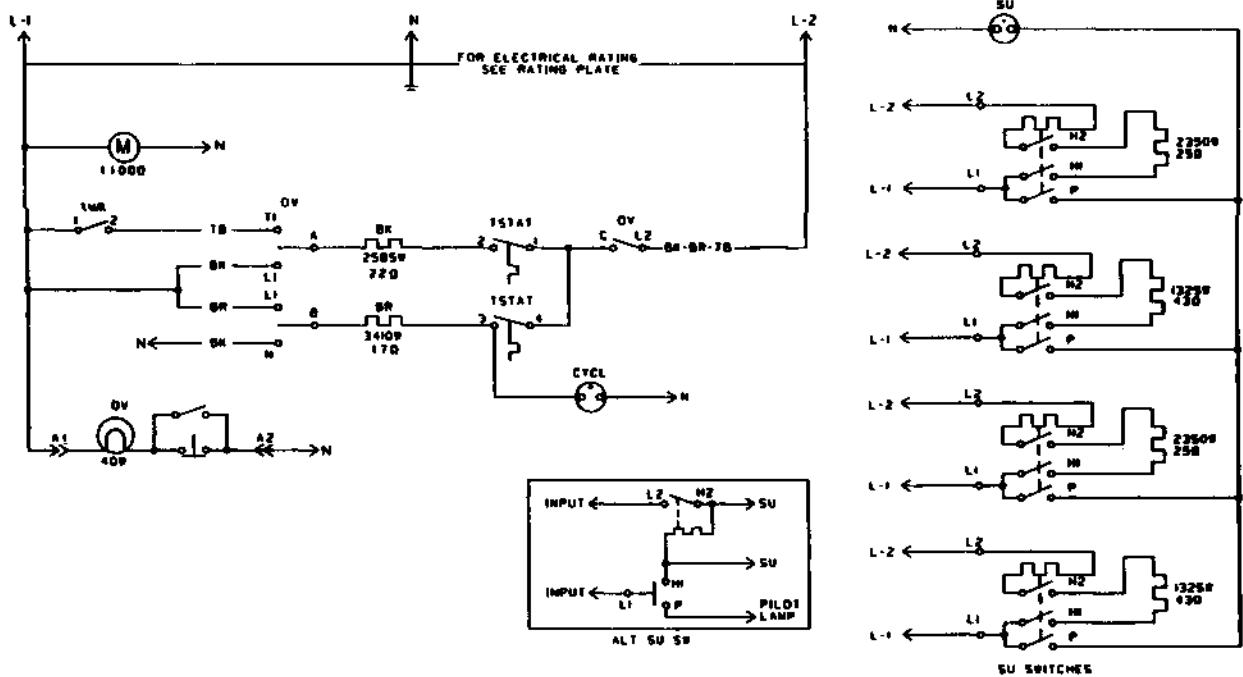

# WIRING DIAGRAM

164D8001 SH 20

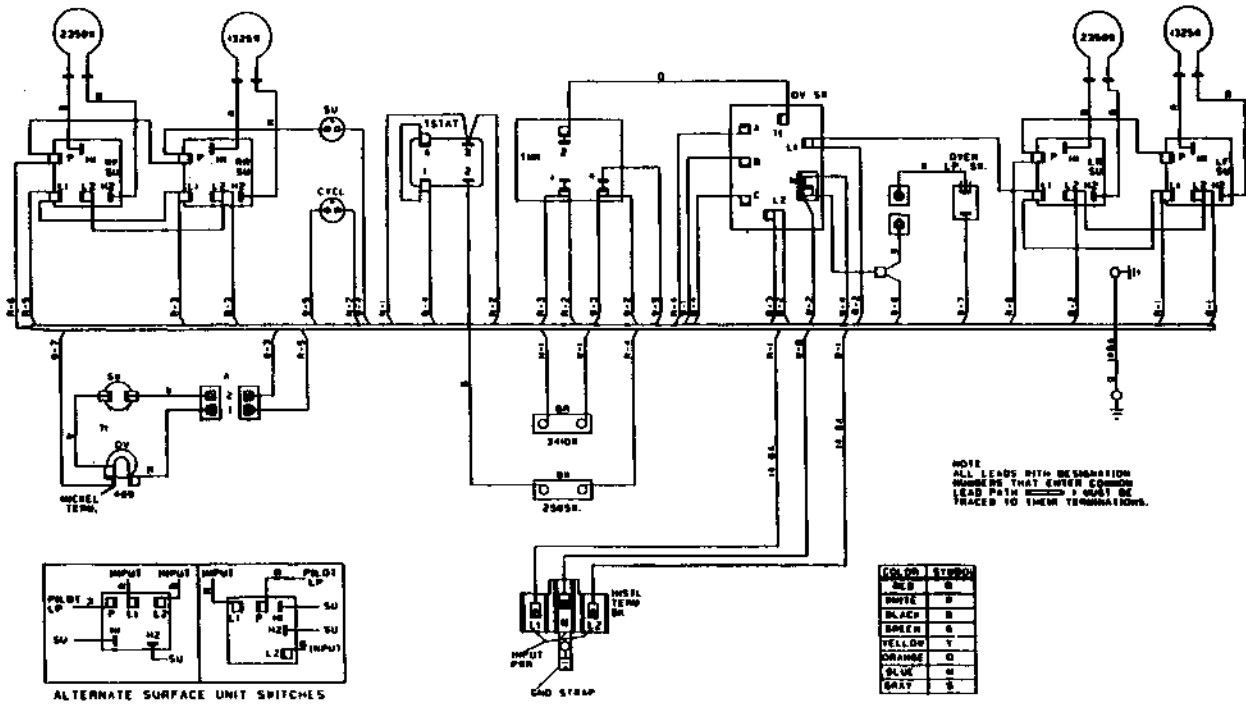

NOTE: FOR SERVICE REPLACEMENT USE 16 GA. 150°C WIRE EXCEPT AS INDIVIDUALLY NOTED ON LEADS. ALL 150°C WIRE COLOR DESIGNATED BY HASH MARK.

# SCHEMATIC DIAGRAM

DWG. NO. 164D8657P001

**WARNING**  
POWER MUST BE DISCONNECTED  
BEFORE SERVICING THIS APPLIANCE

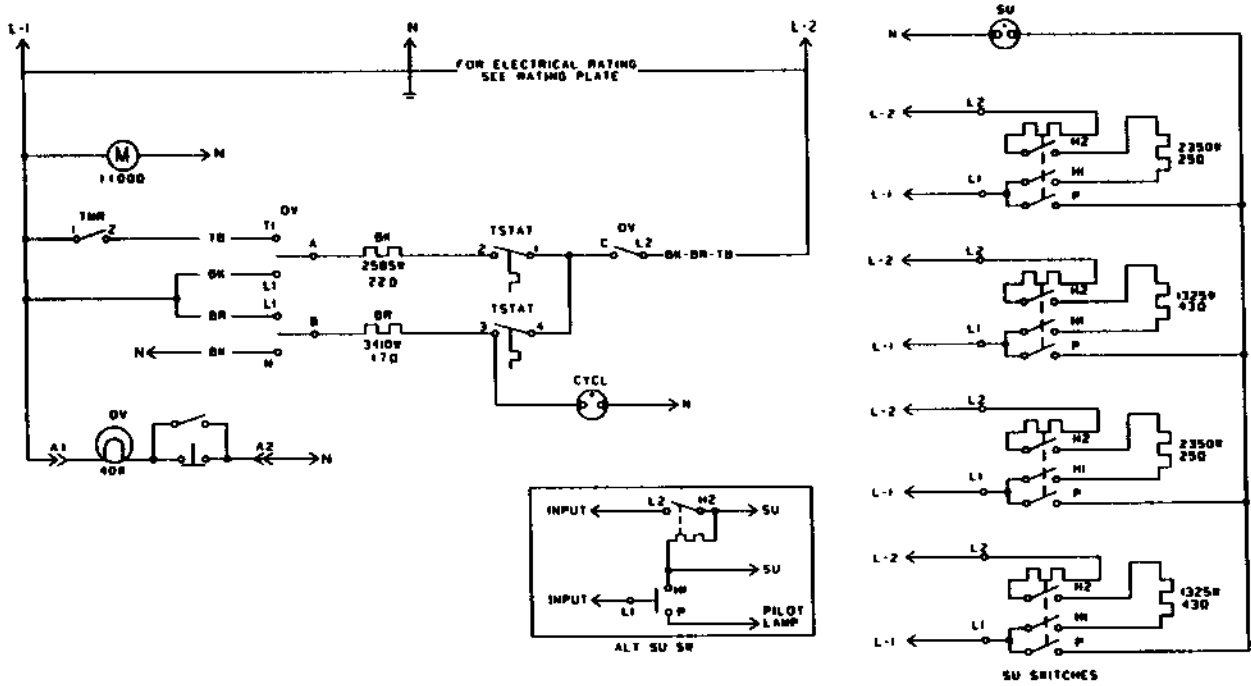

# WIRING DIAGRAM

164D8001 SH 21

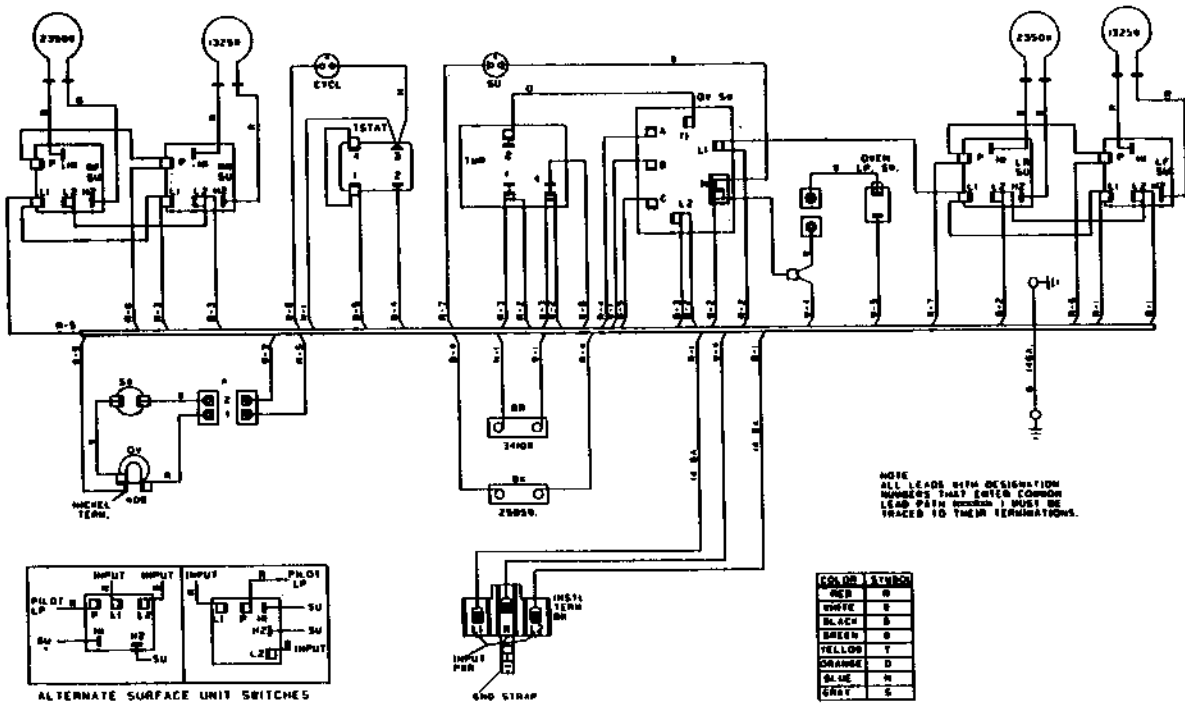

NOTE: FOR SERVICE REPLACEMENT USE 16 GA. 150°C WIRE EXCEPT AS INDIVIDUALLY NOTED ON LEADS. ALL 150°C WIRE COLOR DESIGNATED BY HASH MARK.

# SCHEMATIC DIAGRAM

**WARNING**  
POWER MUST BE DISCONNECTED  
BEFORE SERVICING THIS APPLIANCE

164D8654P001

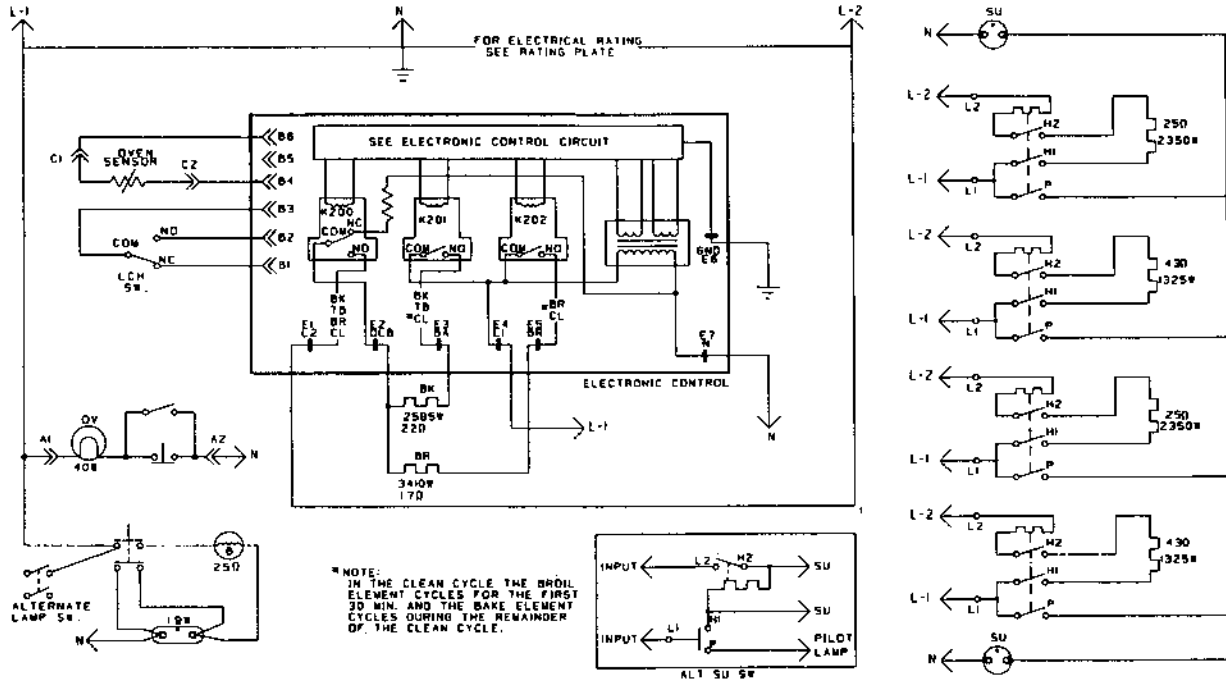

# WIRING DIAGRAM

**WARNING**  
POWER MUST BE DISCONNECTED  
BEFORE SERVICING THIS APPLIANCE

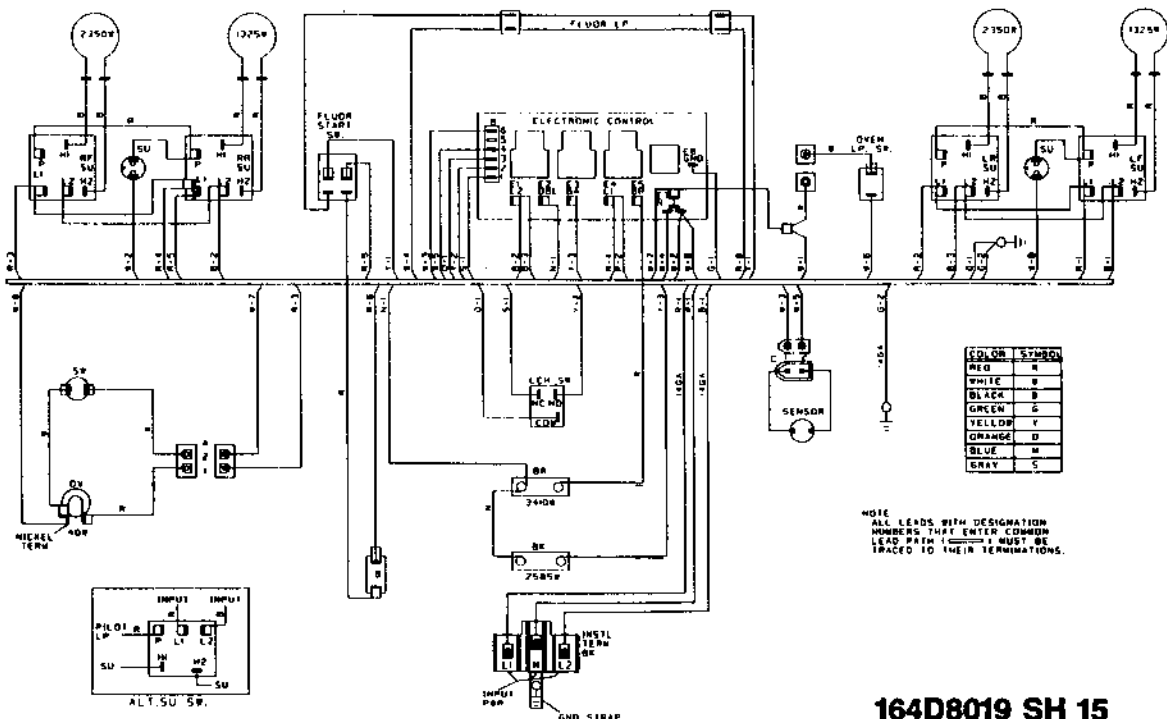

164D8019 SH 15

**NOTE: FOR SERVICE REPLACEMENT USE 16 GA. 150°C WIRE EXCEPT AS INDIVIDUALLY NOTED ON LEADS. ALL 150°C WIRE COLOR DESIGNATED BY HASH MARK.**

# SCHEMATIC DIAGRAM

**WARNING**  
POWER MUST BE DISCONNECTED  
BEFORE SERVICING THIS APPLIANCE

164D8653P001

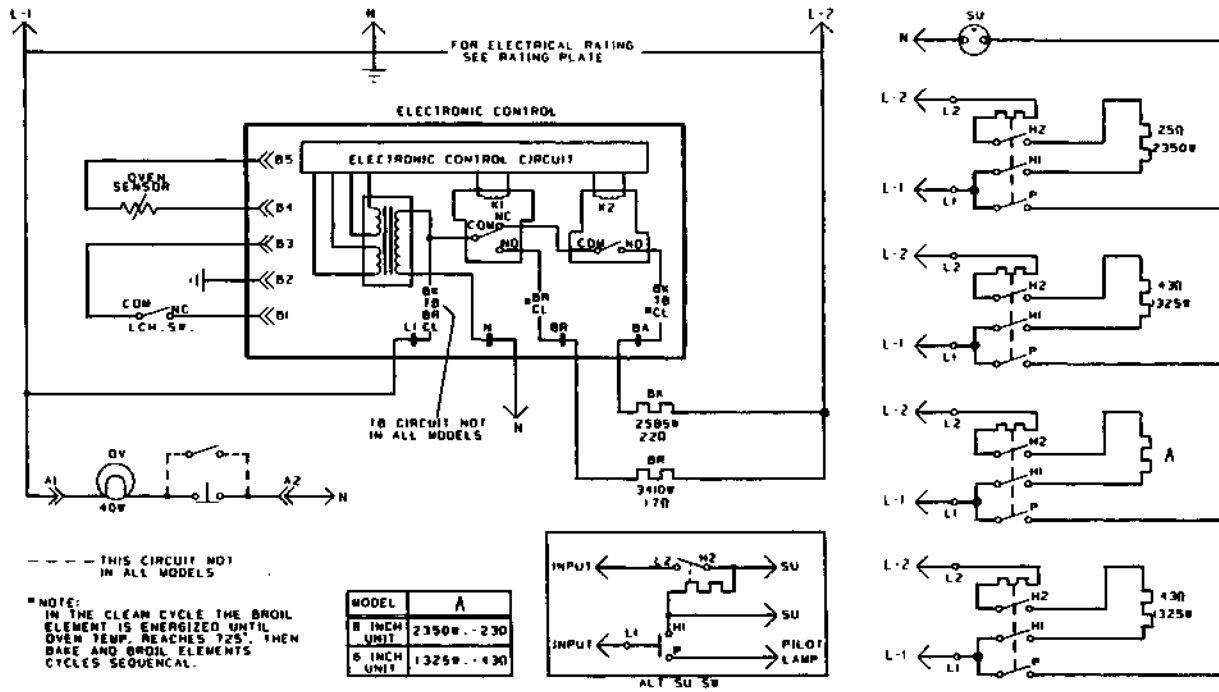

# WIRING DIAGRAM

**WARNING**  
POWER MUST BE DISCONNECTED  
BEFORE SERVICING THIS APPLIANCE

164D8019 SHEET 14

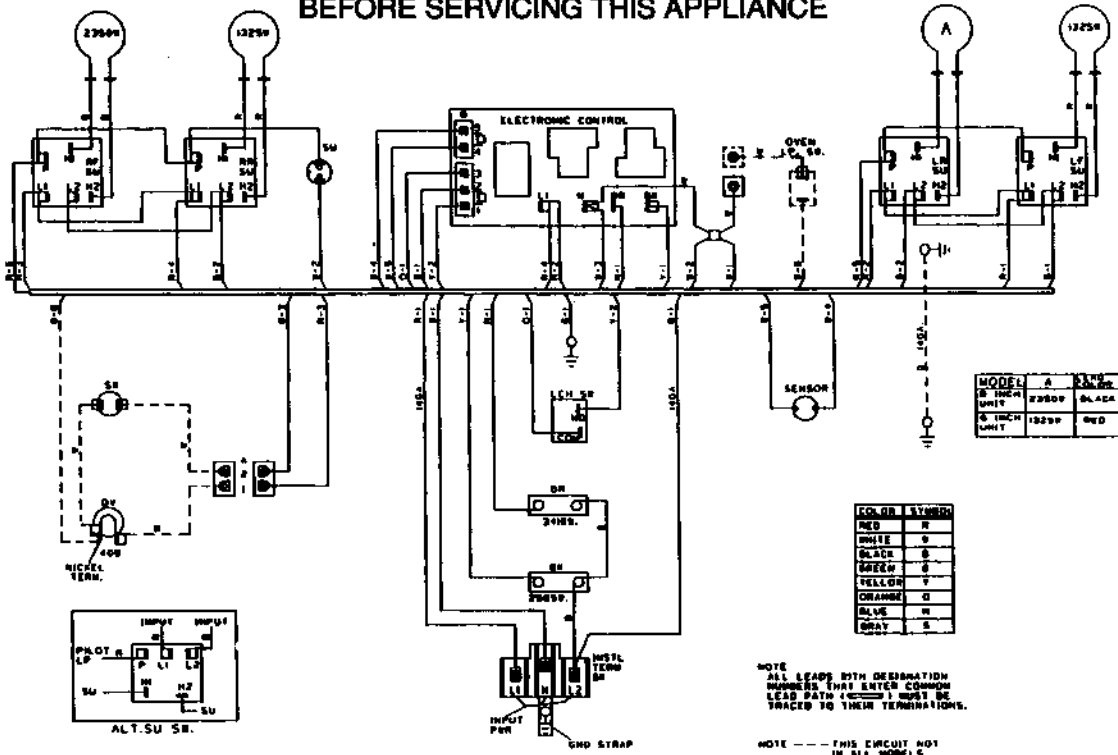



# SCHEMATIC DIAGRAM

DWG. NO. 164D8640P001

**WARNING**  
POWER MUST BE DISCONNECTED  
BEFORE SERVICING THIS APPLIANCE

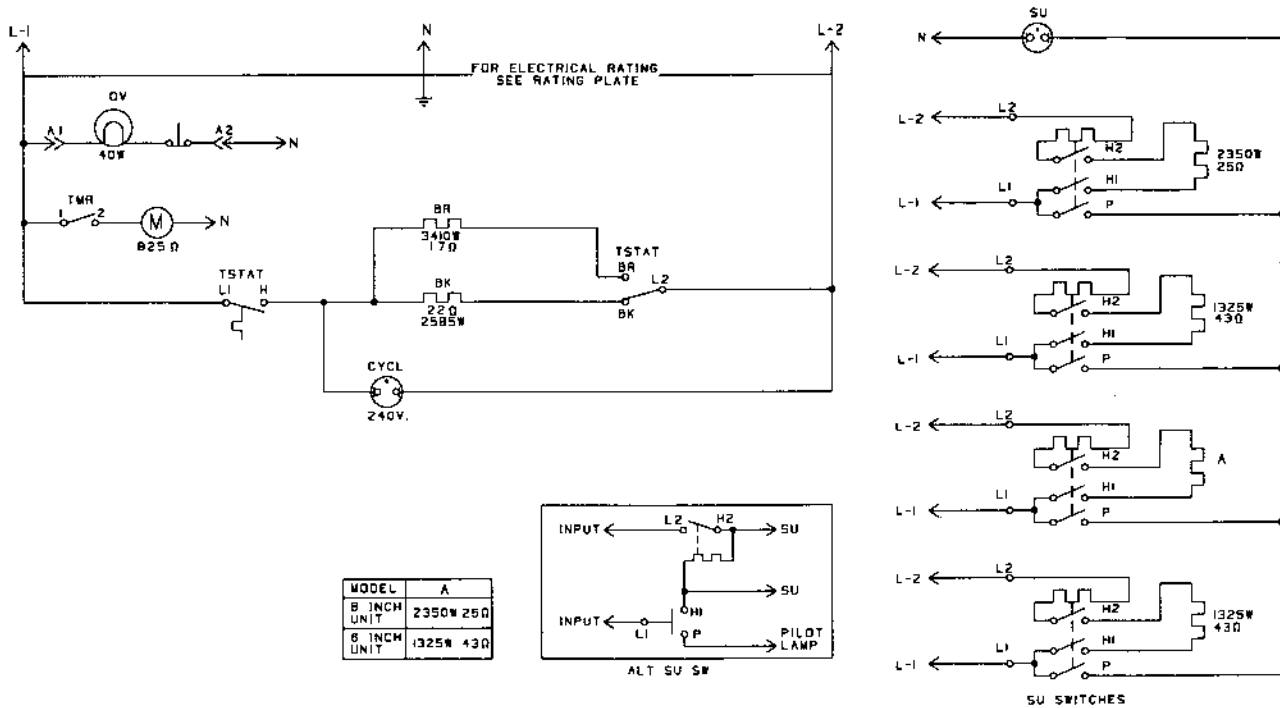

# WIRING DIAGRAM

164D8001 SH 15

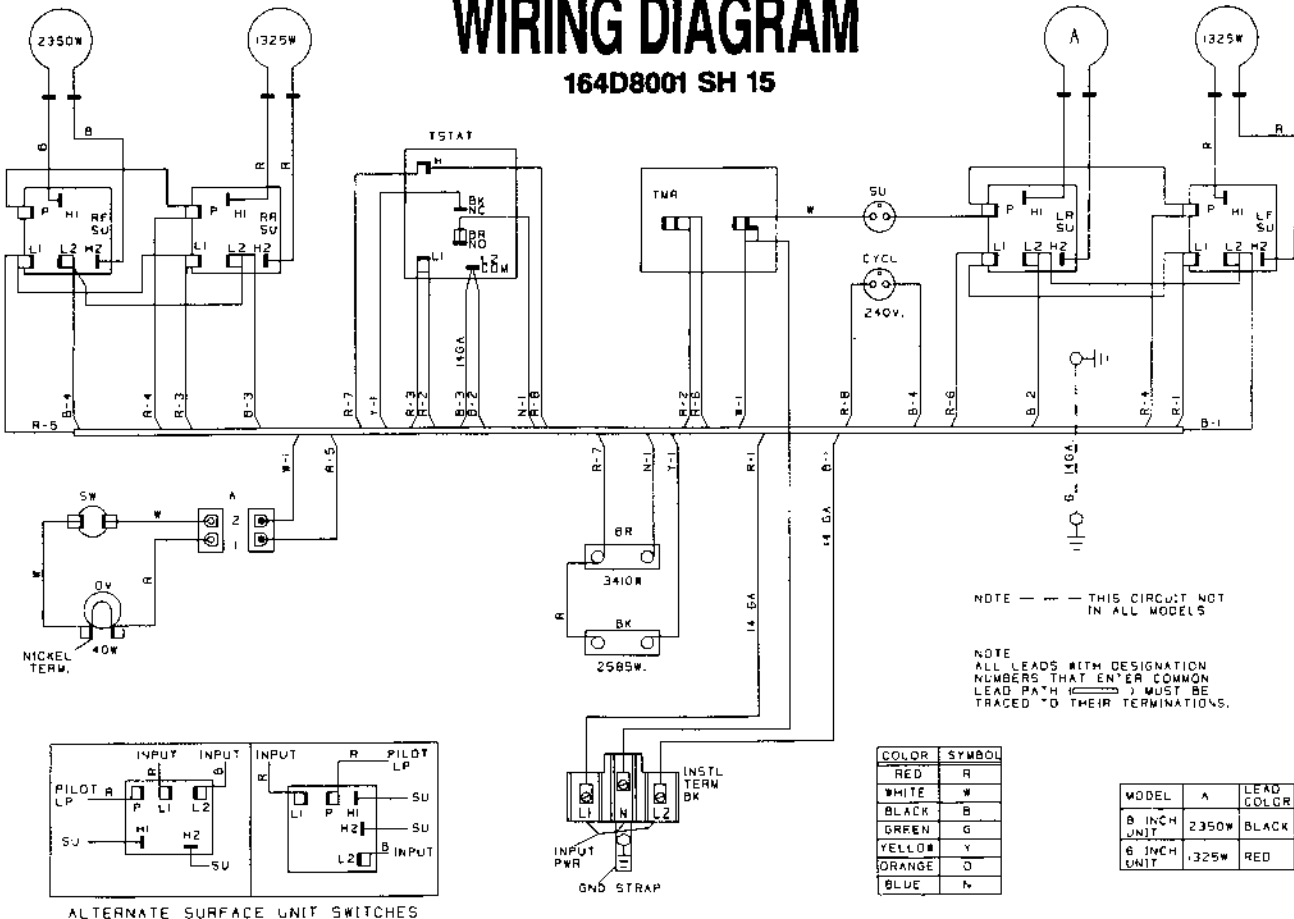

**NOTE: FOR SERVICE REPLACEMENT USE 16 GA. 150°C WIRE EXCEPT AS INDIVIDUALLY NOTED ON LEADS. ALL 150°C WIRE COLOR DESIGNATED BY HASH MARK.**

# SCHEMATIC DIAGRAM

164D8652P001

**WARNING**  
POWER MUST BE DISCONNECTED  
BEFORE SERVICING THIS APPLIANCE

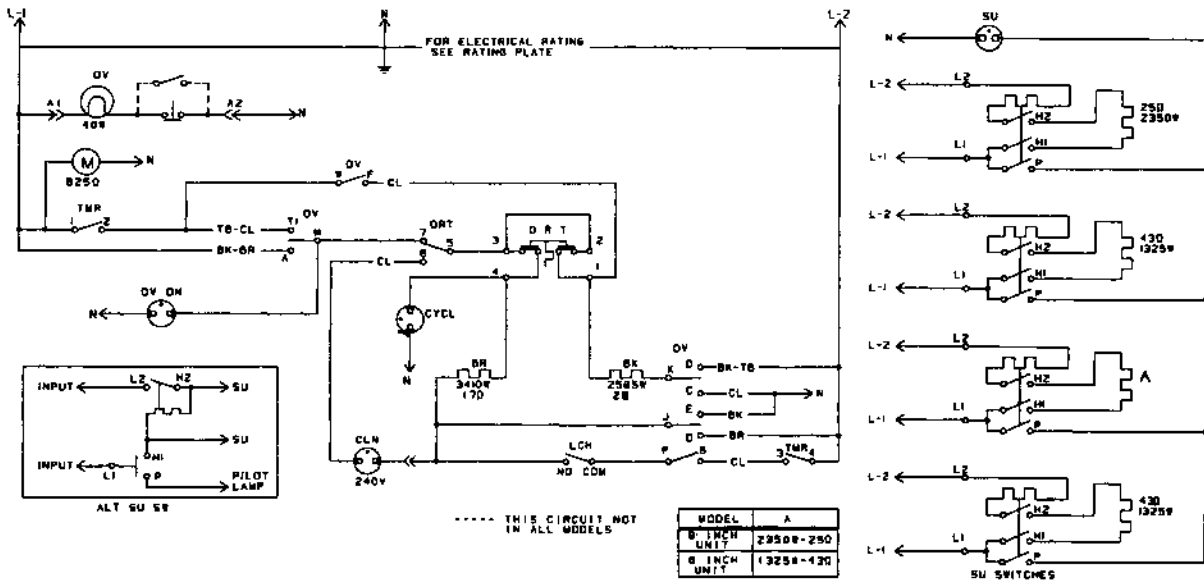

# WIRING DIAGRAM

164D8019 SH 17

**WARNING**  
POWER MUST BE DISCONNECTED  
BEFORE SERVICING THIS APPLIANCE

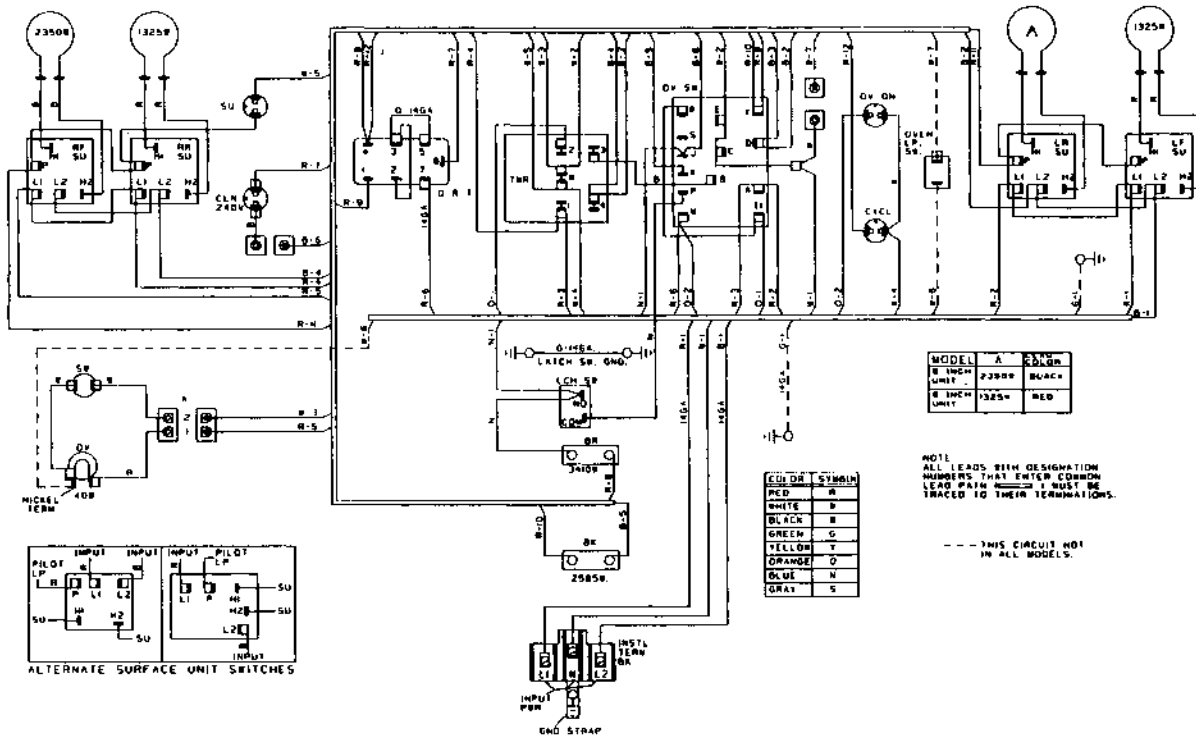

**NOTE: FOR SERVICE REPLACEMENT USE 16 GA. 150°C WIRE EXCEPT AS INDIVIDUALLY NOTED ON LEADS. ALL 150°C WIRE COLOR DESIGNATED BY HASH MARK.**

# SCHEMATIC DIAGRAM

164D8655P001

**WARNING**  
POWER MUST BE DISCONNECTED  
BEFORE SERVICING THIS APPLIANCE

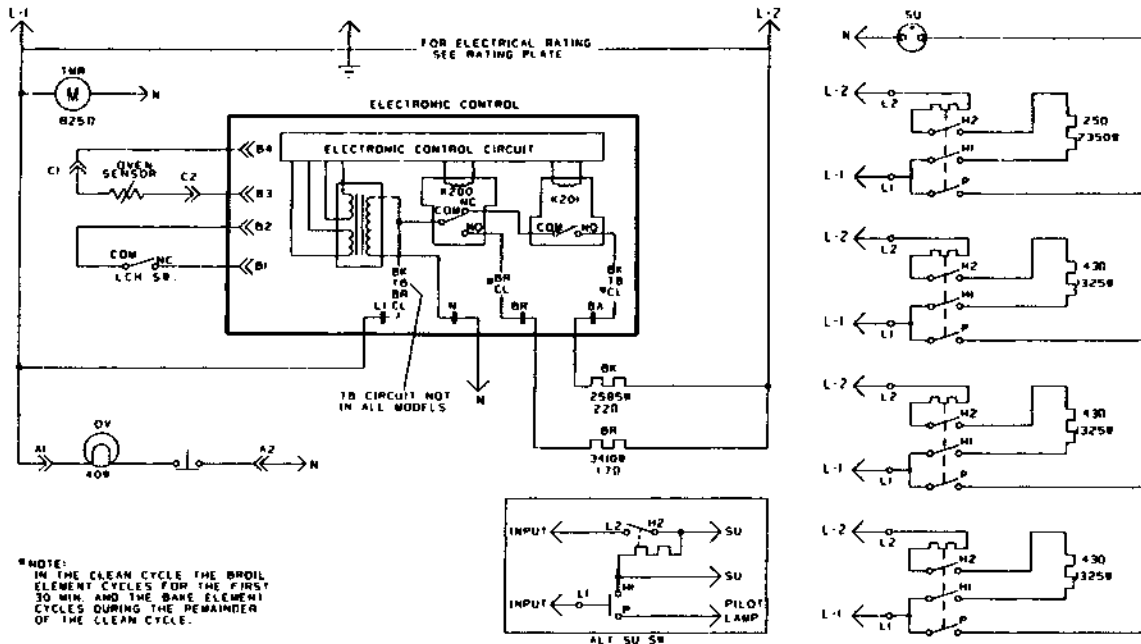

# WIRING DIAGRAM

164D8019 SH 16

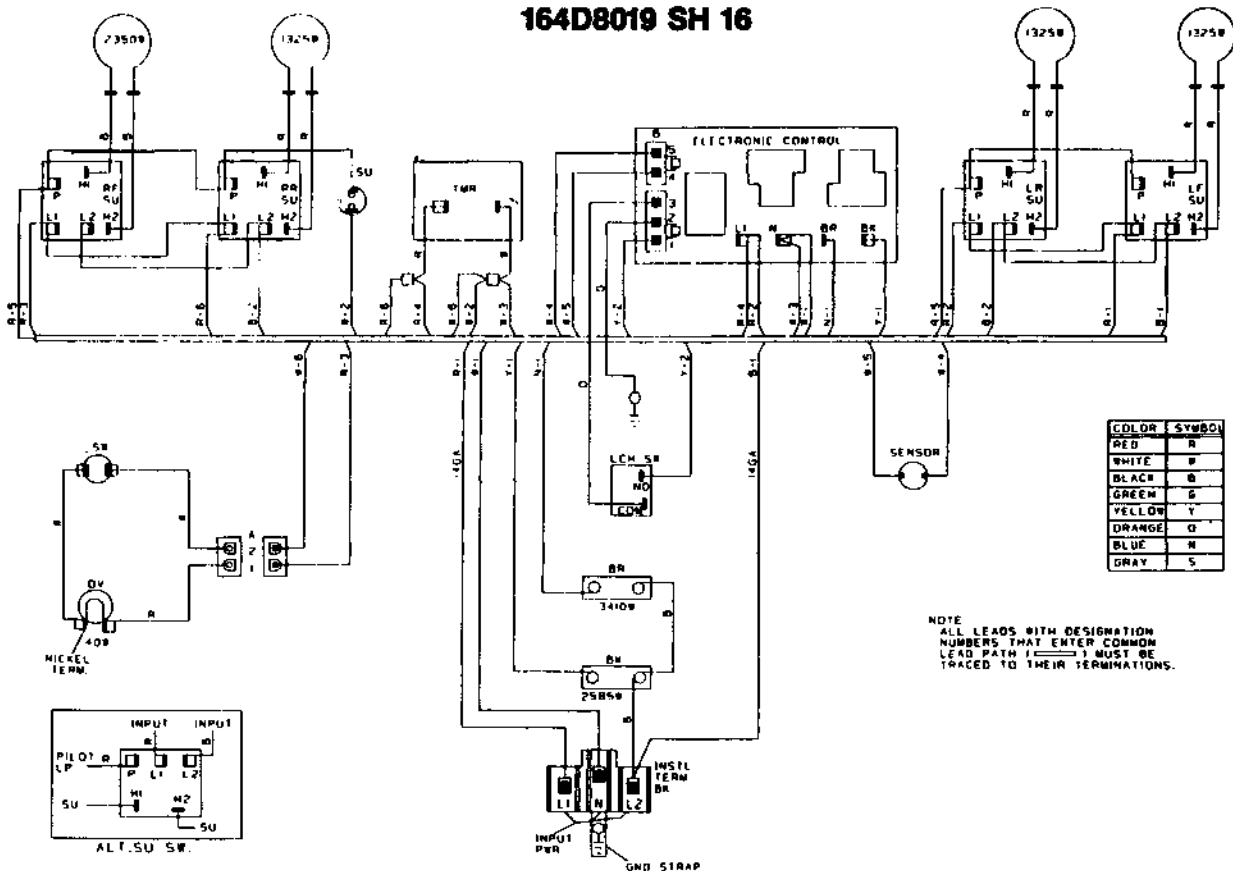

**NOTE: FOR SERVICE REPLACEMENT USE 16 GA. 150°C WIRE EXCEPT AS INDIVIDUALLY NOTED ON LEADS. ALL 150°C WIRE COLOR DESIGNATED BY HASH MARK.**