



GE Appliances

# TECHNICIAN'S MANUAL

G.E. & PROFILE  
30" BUILT-IN WALL OVENS

G.E. MODELS  
JTP13GT1  
JTP14WT1

PROFILE MODELS  
JTP16GT1  
JTP17WT1  
JTP18WT1

REF94  
Pub. No. 31-20105



## 30" Built - In Wall Oven

# Contents

1. Model Families	page no. 1
2. Convection Accessories	Page no. 2
3. Rating Plate / Mini-Manual	Page no. 3
4. Installation	page no. 3
5. Air Flow	page no. 4
6. Oven Door Assembly	page no. 5
7. Door Hinges	page no. 7
8. Control Panel Access	page no. 8
9. ERCII Control Operation	page no. 9
10. ERCII Control System	page no. 12
11. ERC Convection Control Operation	page no. 15
12. ERC Convection Control System	page no. 19
13. Convection Bake & Fan Assembly Access	page no. 24
14. Mortorized Door Lock System	page no. 25
15. Thermal Limit Switches	page no. 26
16. Schematic / Wiring Diagrams	page no. 28

# 30" Built - In Wall Oven Series

A new 30" Built - In Wall Oven with flush look design went into production during the summer of 1994. There will be both a GE model family and a Profile model family. These models will replace the current 30" wall ovens (model nos. JTP10 & JTP11).

## GE Model Family

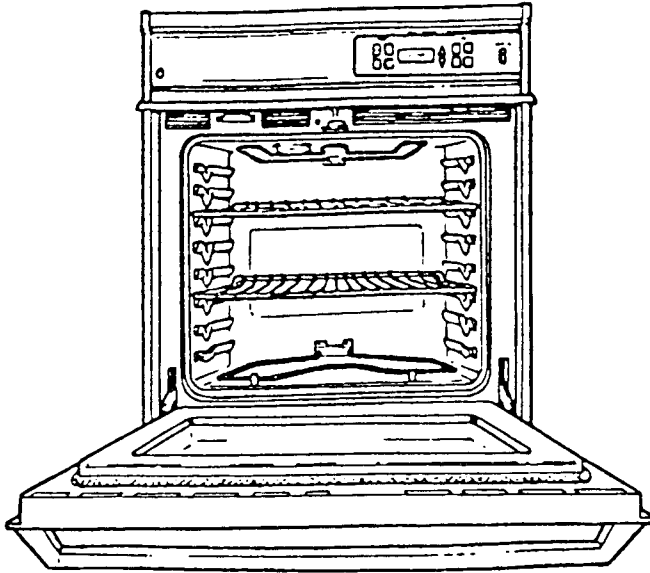

### Features:

- ERCII Self Clean Range Control
- Motorized Door Lock System
- 4.2 cubic foot oven cavity
- 3600 Watt Broil Unit
- 2585 Watt Bake Unit
- Full Glass Large View Window Door
- Six (6) Oven Shelf Positions
- Installs in Wall or Under Countertop
- Calrod, Gas or Radiant Cooktops can be installed above ovens.

### Model Nos.

JTP13GT1 - Black on Black  
JTP14WT1 - White on White

### Features:

- Electronic Self Clean Range Control With Convection Bake and Roast.
- Food Temperature Probe
- Motorized Lock Motor
- 3.8 Cubic Foot Oven Cavity
- 2500 Watt Convection Bake Unit
- 3600 Watt Broil Unit
- 2585 Watt Bake Unit
- Full Glass Large View Window Door
- Soft Touch Door Handle
- Seven (7) Shelf Positions
- Installs in Wall or Under Countertop
- Calrod, Gas or Radiant Cooktops can be installed above ovens.

## Profile Model Family

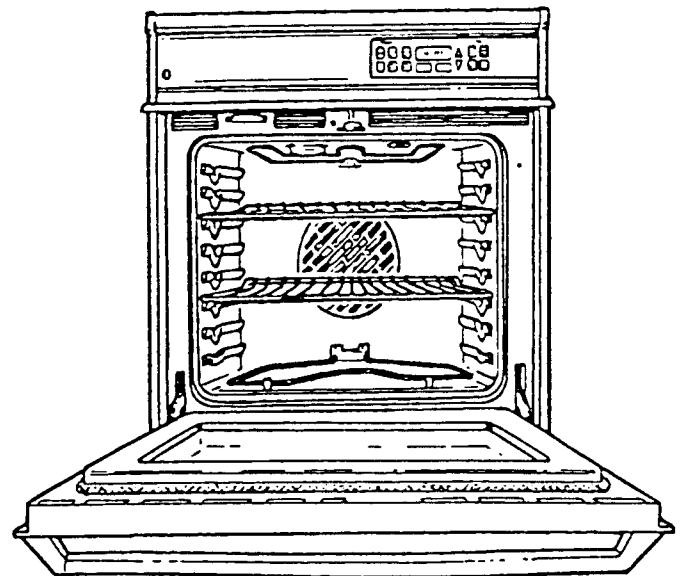

### Model Nos.

JTP16GT1 - Black on Black  
JTP17WT1 - White on White  
JTP18AT1 - Almond on Almond

### Convection Oven Accessories:

#### 7 Shelf Positions:

Convection models come with three shelves. Additional shelves can be ordered in 2 shelf kits (Pub No. 3-A014).

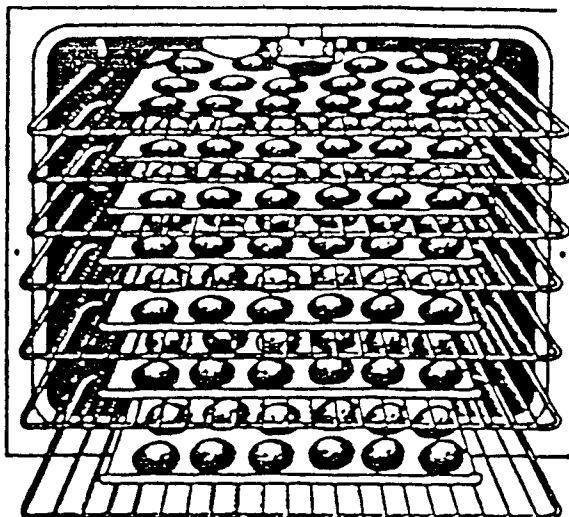
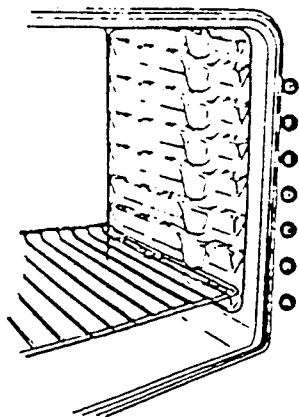

1 to 7 shelf convection baking is possible.

#### Oven Shelf Removal and Replacement:

To Remove Oven Shelf - pull forward and tilt up the front to clear raised extension on rear of shelf.

To Replace Oven Shelf - place the shelf on the desired shelf support (curved extension of shelf) facing up and toward rear of oven. Tilt up front of shelf and push toward back of oven until it goes past the bump on the oven shelf support.

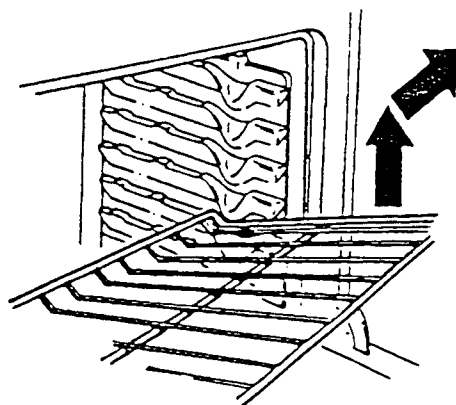

#### Convection Roasting Rack:

The Roasting Rack is designed to fit on top of the broiler pan and grid. This permits the heated air to circulate under the meat and increase the browning on the underside of the meat or poultry.

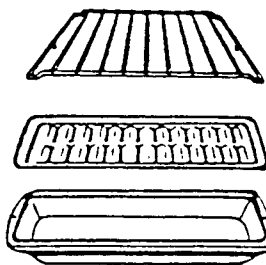

#### Temperature Probe:

Convection Profile models come with the temperature probe feature. The Probe Outlet is located on the top right front of the oven cavity.

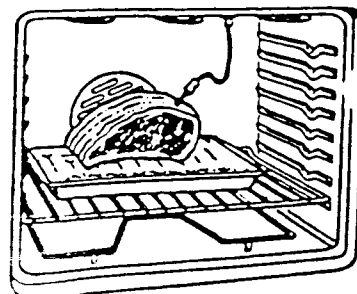

## 30" Built - In Wall Oven

### Rating Plate and Mini - Manual / Schematic Wiring Diagram Locations:

- Rating Plate is located on the LOWER LEFT corner of the front frame behind oven door.
- Mini-Manual is located on rear wall of component compartment behind control.

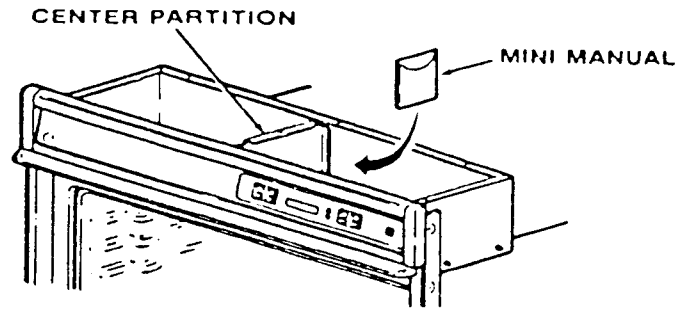

### Installation:

The oven can be either installed into a wall cabinet or mounted underneath a countertop. When installed below a countertop either a GE 30" or 36" Calrod, Gas or Radiant Cooktop can be mounted above it.

### To Remove From Installation:

1. Disconnect Power and remove oven door.
2. Remove lower trim by Pushing Up and then Pulling Forward.
3. Remove 4 screws from oven front frame.
4. Pull the oven forward.
5. Reinstall in reverse order.

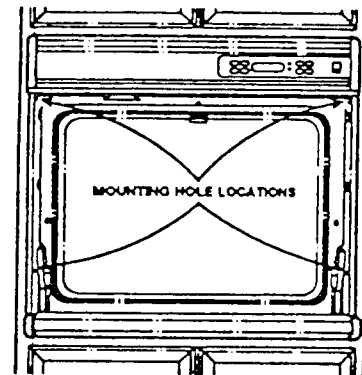
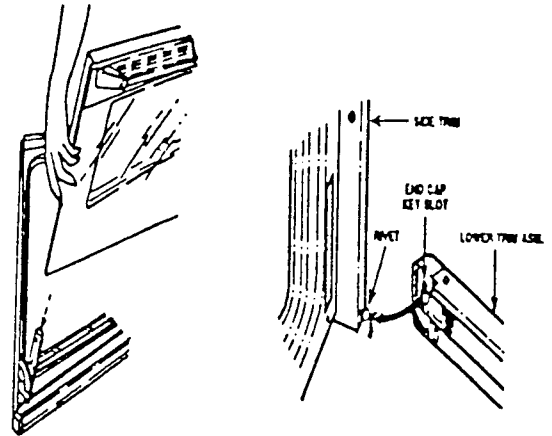

### Types of Installations:

#### Wall-Mount or Cabinet Installation Single Oven (in inches)

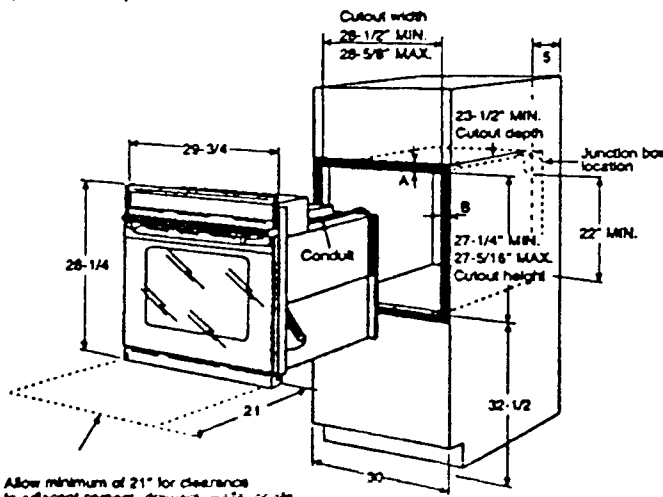

Allow minimum of 21" for clearance to adjacent cabinet, drawers, etc.

A- Allow 1" overlap of oven over top and bottom edges of cutout

B- Allow 1/16" for overlap of oven over side edges of cutout

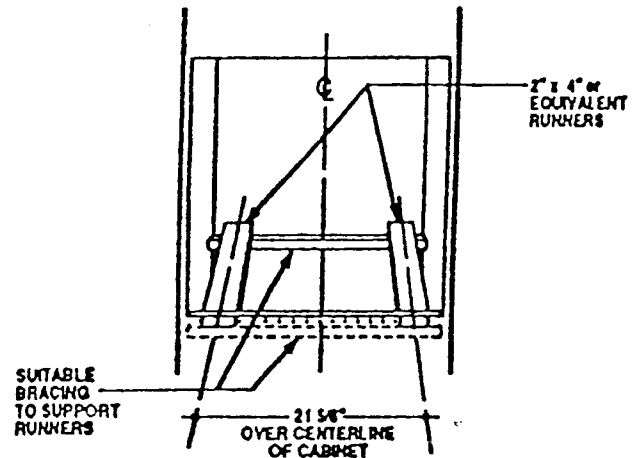

MUST SUPPORT 150 LBS.

**Undercounter Installation for Gas or Electric Cooktops (in inches)**

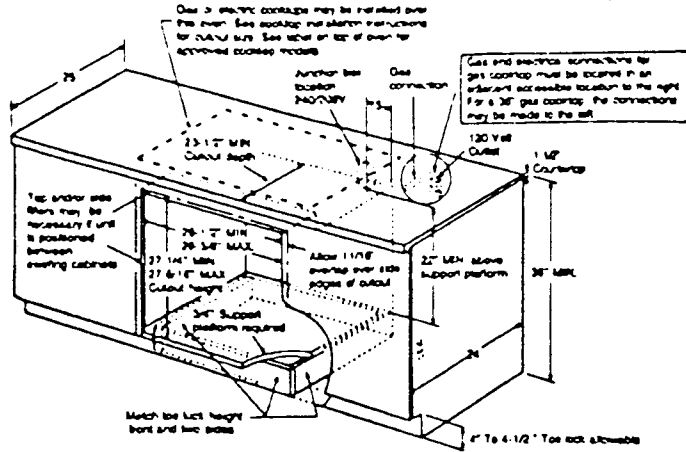

**Installation Information:**

Before installing, consult installation instructions packed with product.

Note: Oven is rated for use with under the following cooktops:

- GE 30" and 36" electric coil and 30" radiant cooktops
- GE 30" and 36" gas radiant and sealed burner cooktops

Note: Gas or electric cooktops may be installed over this oven. See cooktop installation instructions for cutout size. See label on back of oven for approved cooktop models.

**Optional Custom Installation for 30" Radiant Cook Only (in inches)**

This installation is to achieve minimum gap between bottom of counter and control panel.  
Note: For this installation, the bottom trim will not be flush with a typical 4" toe kick.

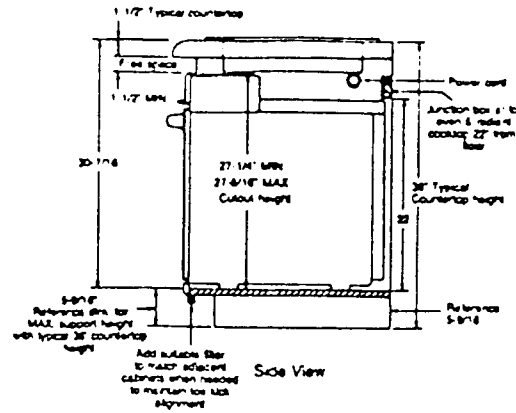

**Installation with Gas Cooktop (in inches)**

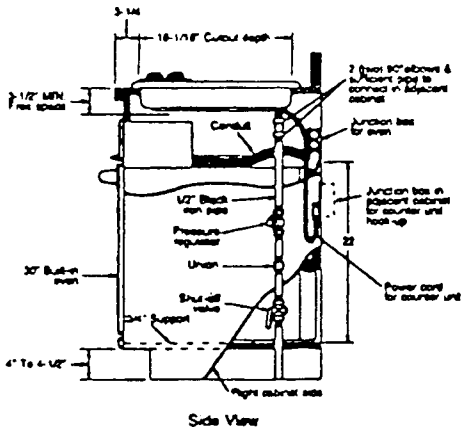

**Installation Information:**

Before installing, consult installation instructions [Pub. No. 31-1152 (JTP18AT/17WT/16GT/14WT/13GT)] packed with product for current dimensional data and for alternate installation options.

**Component Compartment Air Flow:**

The component compartment contains two (2) fans for cooling the components located on the rear wall of the component compartment. Fan blades pull air in from the back of the unit and circulate it in the component area. The air is then exhausted out through the louvers just below the control panel assembly. The air then travels either above the top of the door or through slots in the area above the inner door panel and exits out behind the door handle.

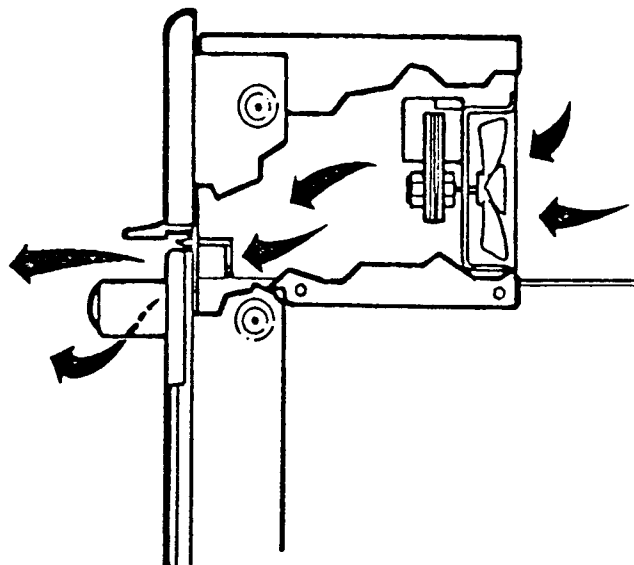

## 30" Built - In Wall Oven

### Oven Door:

The door assembly can be broken down into two basic assemblies: (1) Outer assembly that consists of door handle, outer glass, bottom trim and frame. (2) Inner assembly that is made up of inner panel, gasket, glass panels (3) and vent.

### To Replace Outer Glass Panel:

1. Open door to first stop and lift off hinges.
2. Remove 6 screws from bottom trim and lift off.
3. Slide glass out from under vent trim and lift off.
4. Reassemble in reverse order.

### To Replace Door Handle, Top Trim or Frame:

1. Open door to first stop and lift off hinges.
  2. Remove 4 screws from bottom trim (do not remove two 2 outside screws).
  3. Remove 4 screws from side trim (2 on each side). Leave top screws on each side.
  4. Remove two screws that mounts the \*door handle and heat deflector. The end caps can also be removed by sliding out.
  5. To replace the vent trim the two screws on the side trim must be removed.
  6. Reassemble in reverse order.
- \* NOTE: Door handle on JTP16, 17 & 18 is a one piece soft touch handle.

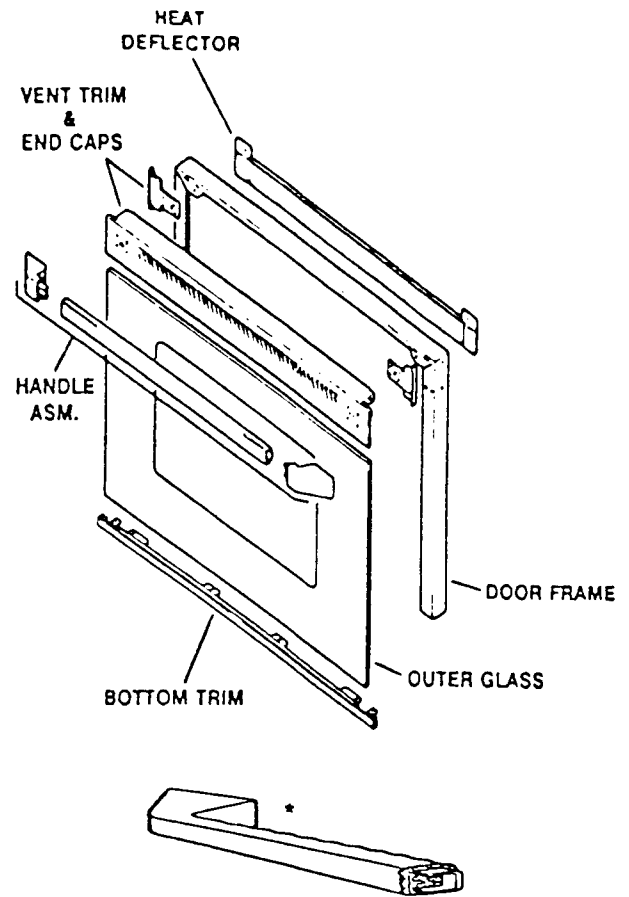

### To Replace Middle and Inner Glass:

1. Separate door into two assemblies (Inner and Outer).  
(Middle Glass Access)
2. Remove two screws from inner door assembly that mounts one of the middle glass retainers. Middle glass can then be pulled out of other retainer.  
**Note:** Middle Glass does not have any reflective coating.  
(Inner Glass Access)
3. Remove six screws mounting Insulation Retainer and lift off.
4. Remove four strips of Insulation from around Inner Window Assembly.
5. Remove the four screws and mounting clips from inner panel. Inner Glass and frame can then be removed.  
**Note:** Both Inner Glass Panes have Reflective Coating on both sides of the glass.
6. Reassembly in reverse order.

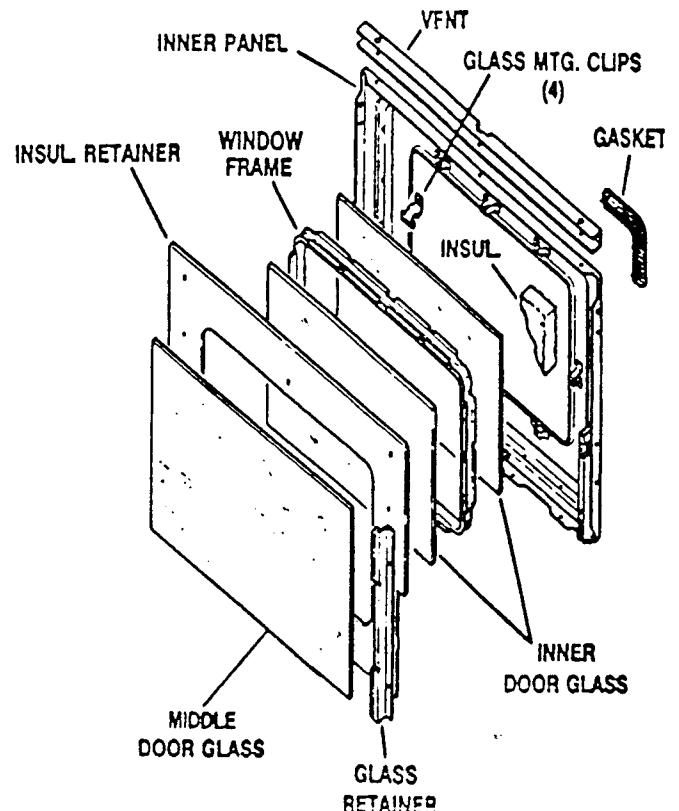

Oven Door Gasket:

The Gasket forms a seal around the front edge of the oven liner and the inner door panel except for approximately a six inch opening at the center bottom. The gasket is attached to the inner door panel by a chain of spring clips.

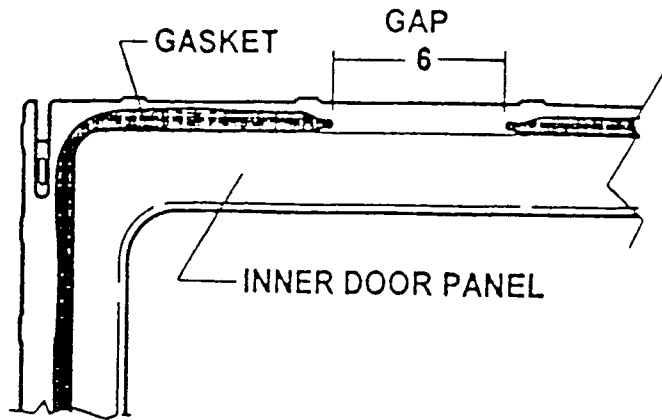

To Remove Door Gasket:

1. Open door to Broil Stop position and lift off range. Lay door face down on a flat protected surface.
2. Pull ends of gasket out of the slots at the bottom of the door.
3. Finish removing gasket by placing finger under gasket beside the clip and pull straight up.

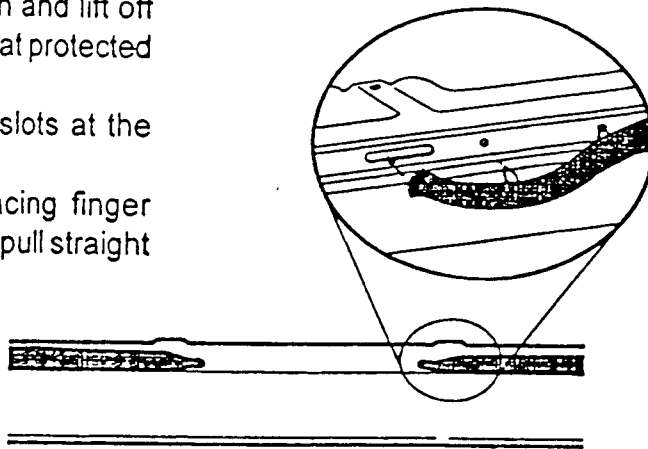

To Install Gasket:

1. Locate the center clip of the gasket.
  2. Place finger on top of spring clip and press into center top hole in inner door panel.
- Note: Gasket will go on better if folded up at 90° beside the clip being inserted.
3. Continue this process all the way around inner panel until all clips have been inserted.
  4. With small screw driver tuck loose ends of gasket into slots at the center bottom of door panel.
  5. After gasket has been installed, wipe finger around outer perimeter of gasket pressing it up against side of inner panel.

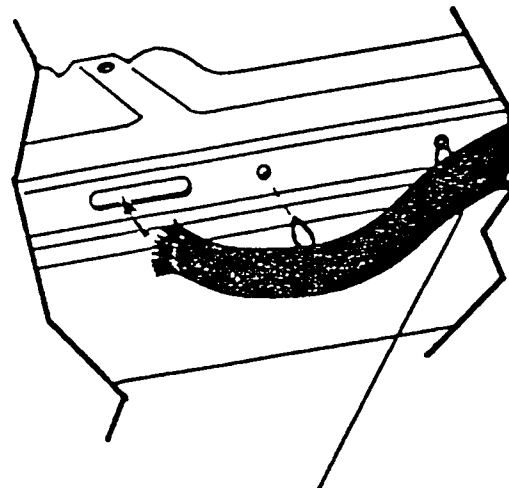

**BEND GASKET 90 DEGREES  
BESIDE CLIP & PRESS DOWN**



## 0" Built - In Wall Oven

### Door Hinge Assemblies:

The door hinge comes as a complete assembly. The hinges come as a left or right hinge and will be stamped with either a "L" or "R". The spring on the hinges is also mounted differently. For the hinges to operate properly the hinge arms should be perpendicular to the front frame and parallel to each other.

The right hinge has the hook of the spring turned down at the top and turned away from the oven cavity at the bottom. The left hinge has the spring hook turned down at the top and turned away from the oven cavity.

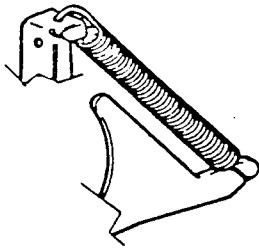

Left Hinge

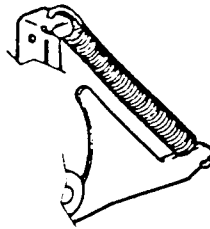

Right Hinge

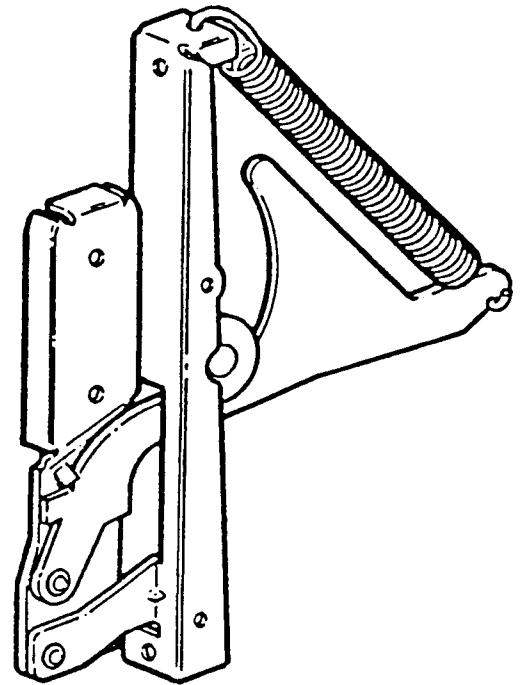

DOOR HINGE ASM.

### Door Hinge Replacement:

1. Open door to first stop and lift door off by firmly grasping on each side and pulling straight up. Be careful not to let the hinge arms snap back on your fingers.
2. Remove four screws mounting oven in wall and slide forward approximately 6". Take necessary precautions to insure that oven does not slip forward.
3. Remove the 2 lower side trim screws and the two screws that mount the hinge to the front frame.
4. Grasp the hinge from the rear and rotate bottom of hinge towards the rear of the oven and while guiding the hinge arm through the slot in the front frame.
5. Reinstall in reverse order.

**Note:** Make sure hinge arms are parallel with each other and perpendicular to front frame. (If not this may cause the hinge to bind on the receiving channel of the door.)

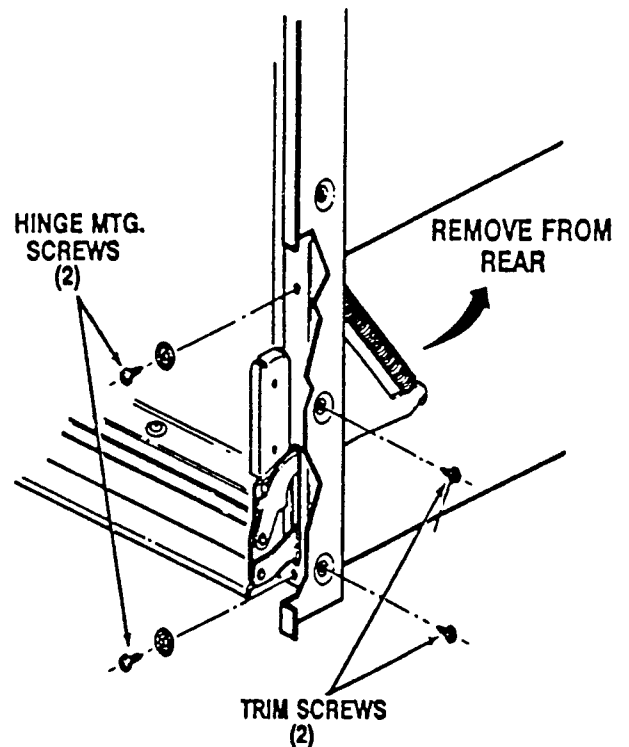

**Control Panel:**

Two basic control panel assemblies exist - ERCII series which consist of the control, key panel, end caps, eyebrow and oven light switch, the other series contains the ERC Convection control, key panel, eyebrow and end caps. Each series also come in different colors.

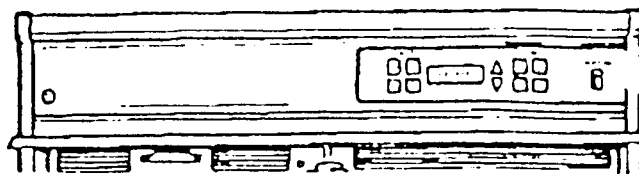

ERCII Control Panel

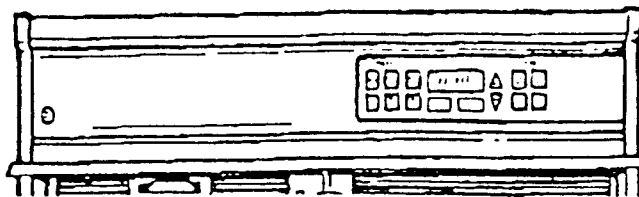

ERC Convection Control Panel

With control panel in service position it provides easy access to fan motor assemblies, fan thermal switch assemblies, oven light socket, control, control transformer on convection models, lock motor assembly and fan on thermal limit switch.

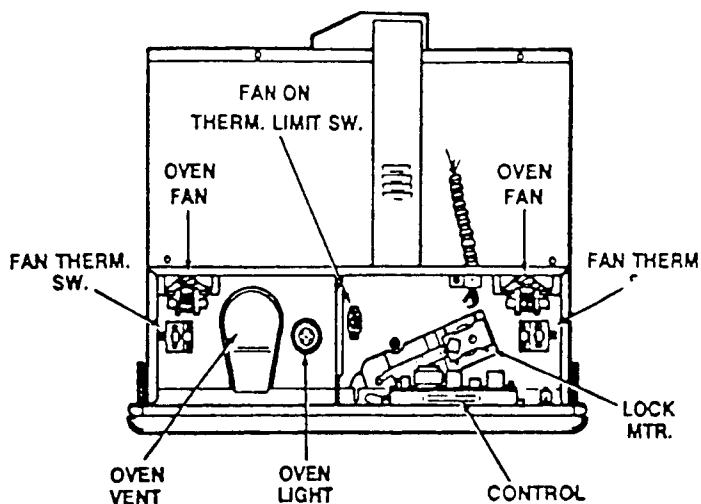

**Control Panel Access:**

1. Disconnect POWER and open oven door.
2. Remove 3 screws from across bottom of control panel.
3. Push up on control panel assembly to release mounting rivets on top corners of end caps.
4. Reinstall in reverse order.

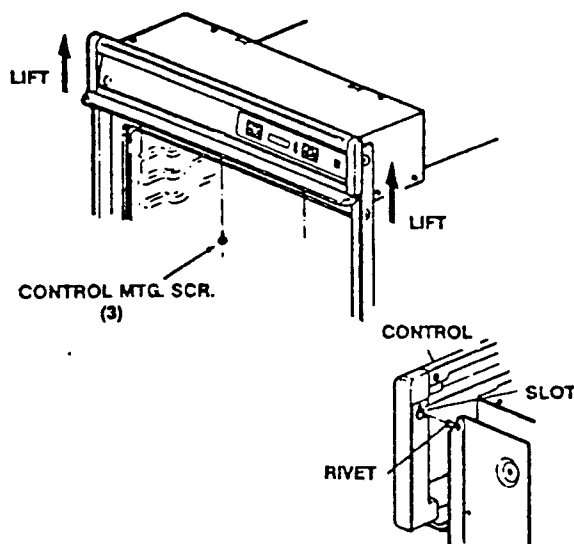

**Oven Controls:**

Two types of electronic controls will be used on the 30" wall ovens.

- ERCII Control with motorized door lock system is used on the GE models.
- ERC Convection Oven Control with motorized door lock system is used on the Profile Line.

**ERCII with Motorized Lock System:**

The control system consists of the Control, Sensor, Sensor Circuit, Lock Motor Assembly, Lock Motor Circuit, Fans and Fan Thermal Switches.

**ERCII Control Operation:**

Power Up or After Power Failure:

All segments of the display will light for about five seconds, then the last set time of day will flash in display until the clock is set or another function is used.

+ / - (Increase / Decrease) Pads:

The following outlines the functions of the + / - (increase / decrease) pads:

- Used to select - time, temperature, start / stop times, HI / LO Broil, Etc.
- + / - (Increase / Decrease) pads will not function unless one of the program pads are touched first.
- The only pads on the control that do not have an audible tone when touched.
- Used to initiate programs - if not touched within 30 seconds control will default back to time of day.

To Set Clock:

- Touch Clock Pad
- Press + / - pad to select correct time of day.

To Set Timer:

- Press Timer pad
- Press + / - pad to select desired time.

**Note:** To stop timer or turn timer off, Press and hold timer pad.

Last minute will count down in seconds.

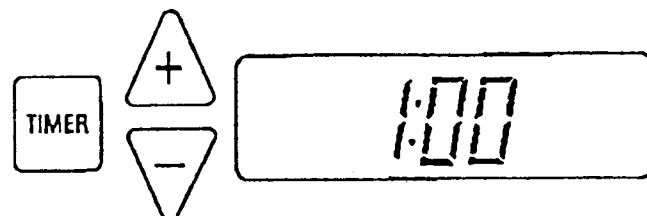
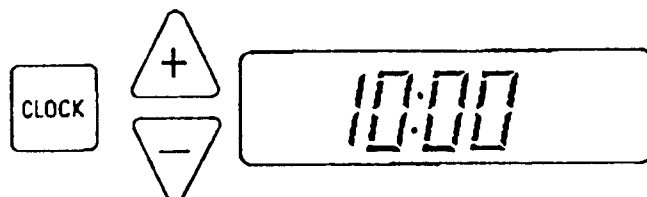
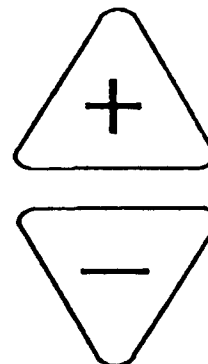
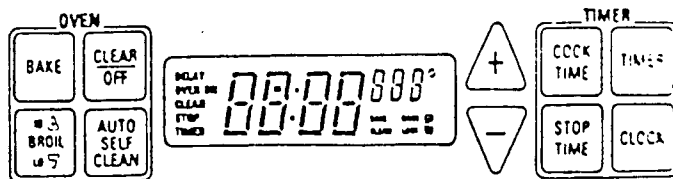

## 30" Built - In Wall Oven

### End of Cycle Tone:

At the "End" of a cycle the control will "BEEP" 3 times followed by a single tone every 6 seconds until cancelled or another function is selected.

The tone every 6 seconds can be eliminated by pressing and holding the CLEAR / OFF pad for 10 seconds. To return tone repeat above step

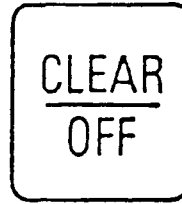

### Bake Operation:

- Touch Bake Pad.
  - \* Control will "BEEP", \_\_\_° and SET Bake will appear in Display.
- Press Increase /Decrease Pad.
  - \* Previous bake temperature will be displayed.
  - \* At initial power up or after power failure 170°F will be displayed.
- Select desired temperature using Increase / Decrease pads. After about 5 seconds the bake relay will close and display will show 100° and ON.

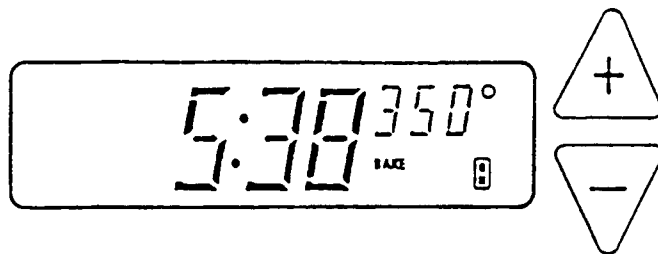
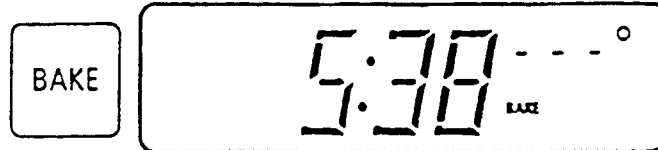

### Time Bake Operation:

- Touch COOK TIME pad
  - \* 0HR:00 and oven time will flash
- Press Increase or Decrease Pad for desired length of baking time.
- Touch BAKE pad and select desired temperature.
  - \* Same procedure as bake.

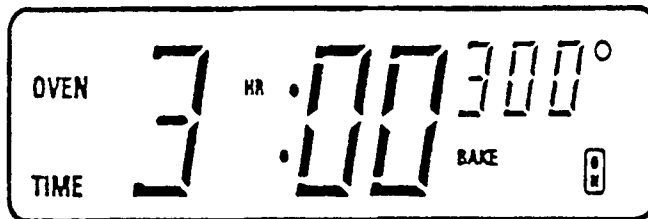

### Delayed Bake Operation:

- Touch COOK TIME pad and select length of cooking time
- Press STOP TIME pad
  - \* Stop Time will flash in display.
- Press Increase / Decrease pad until desired stop time appears in display.
- Touch Bake and select Temperature.
  - \* Same procedure as bake.

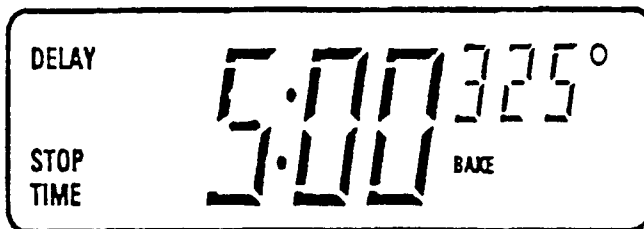



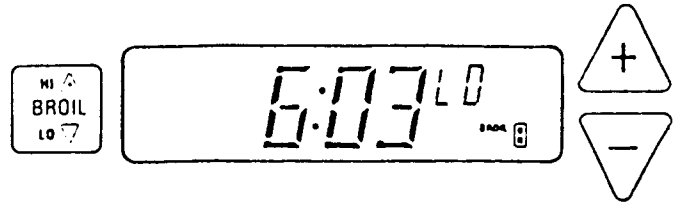

## 30" Built - In Wall Oven

### Broil Operation:

- Open door to broil stop.
- Touch BROIL pad.
  - --- with the word Broil will appear in display.
- Press + pad for Lo Broil (450°F).  
Press + pad again for Hi Broil (550°F).
- LO or HI along with Broil and "ON" will be displayed.

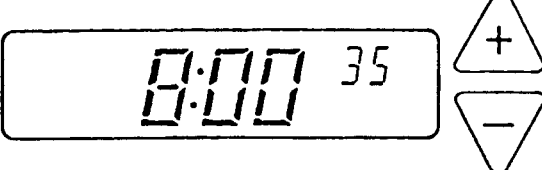

### Bake Temperature Calibration:

<p>The bake temperature can be adjusted by <math>\pm 35^{\circ}\text{F}</math>. from the factory setting. <u>To Adjust The Bake Temperature:</u></p>	
<p>1. Press Bake Pad.</p>	
<p>2. Select any temperature above 500°F. by pressing the + Pad.</p>	
<p>3. <b>Immediately</b> Press and <b>Hold Bake Pad</b> until "00" or previously entered temperature is displayed.</p>	
<p>4. Press the + or - Pad to change the oven temperature +35° or -35° in 5° steps.</p>	
<p>5. Press Clear / Off pad to return to normal operation.</p>	

### Clean Operation:

1. Touch CLEAN pad
  - --- CLEAN TIME flashes in display.
2. Press + or - pad.
  - CLEAN TIME and 3HR: 00 will be displayed and door will lock.

**NOTE:** Clean time can be varied between 2 and 4 hours in 5 minute intervals.

When clean cycle is complete and oven has cooled door will unlock.

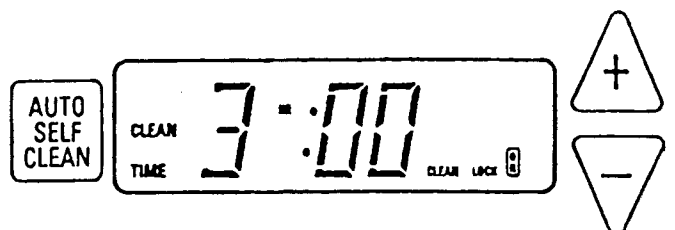

**ERCII Control System:**

The control system is made up of the following components: Single line break control, key panel assembly, sensor and sensor circuit and lock motor assembly and circuit.

**Control:**

The control contains the bake and broil relays, control transformer, lock motor relay, sensor & lock motor connector along with a series of 1/4" terminals for connecting power to the control and heating units.

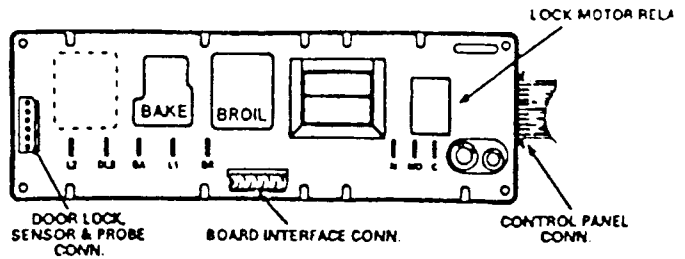

**Control Voltages:**

Terminals	Voltage and Mode of Operation
L1 - N	120 VAC all the time
L1 - BA L1 - BR	240 VAC when oven is not calling for heat (Bake & Broil Relay contacts open)
C - N NO - C	120 VAC all the time 120 VAC when locking or unlocking

**NOTE:** A cooking or cleaning mode of operation must be selected before the relay contacts will operate.

Voltage must be present across terminals L1 to N for the control to operate.

**Oven Circuits:**

**BAKE & TIME BAKE**

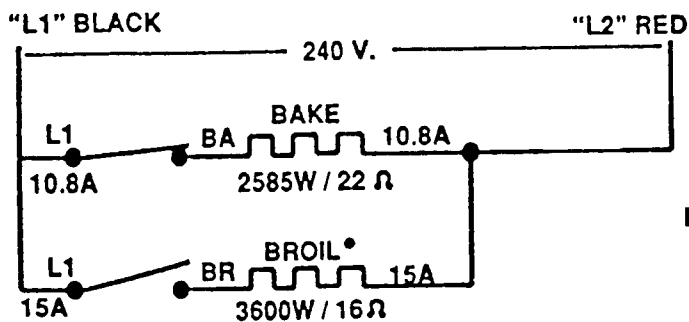

APPROXIMATELY 25% ON-TIME IN BAKE.

- Bake and Broil units cannot be on at same time.
- BAKE ONLY during (pre-heat) cycle.

**BROIL & CLEAN- (FIRST 30 MINS. OR 750°F)**

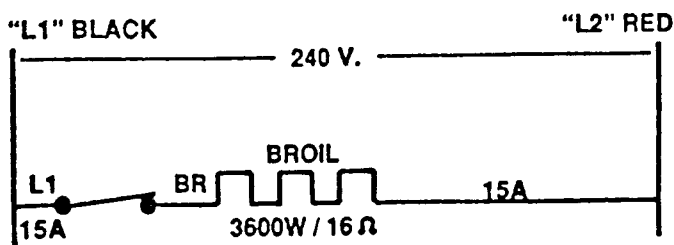

**Bake Mode**

Sequence Cycling of Bake & Broil Units  
After Initial Preheat Cycle

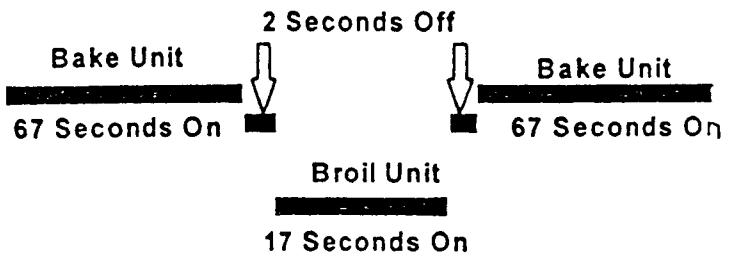

**BALANCE OF CLEAN CYCLE**

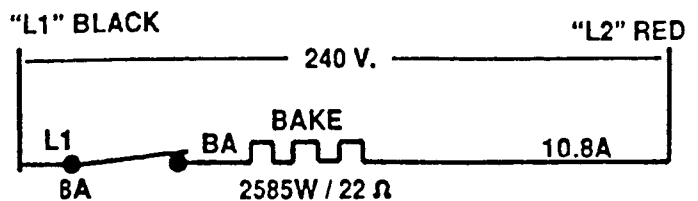

## 30" Built - In Wall Oven

### Key Panel:

The key panel is connected to the control by a ribbon connector. The control will sound a tone when any of the pads are depressed except for the +/- pads.

To help isolate a problem to either the control or key panel, depress each pad on the key panel and observe the following:

- Bake, Broil, Clean, Timer, Clock, Stop Time, and Cook Time Modes - Audible tone plus display showing mode of operation selected.
- Clear / Off - Audible tone and display shows time of day.
- +/- Pads - No audible tone. Can only be used after another function pad has been selected.

If some of the pads work and some don't, the problem is probably with the key panel. To verify that the key panel is the problem check the connector for proper insertion of the ribbon cable and perform the Ohm Test. If the ohmmeter reads  $\infty \Omega$  when depressing the pad or shows some resistance without depressing the pad the key panel is bad.

### Ohmmeter Test:

Set ohmmeter on scale that will read approximately  $500 \Omega$ . Connect leads to ribbon cable as indicated in chart for each function. Depress function pad. Meter should read less than  $\infty \Omega$  if the switch contact is working.

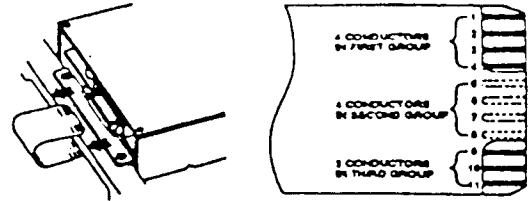

FUNCTION	CONDUCTORS	OHMS
DOWN ARROW	1 TO 2	0 TO 150
UP ARROW	1 TO 3	0 TO 150
BROIL	4 TO 5	0 TO 80
CLEAN	4 TO 6	0 TO 80
BAKE	4 TO 9	0 TO 80
COOK TIME	8 TO 5	0 TO 150
STOP TIME	8 TO 6	0 TO 150
CLOCK	8 TO 7	0 TO 150
TIMER	8 TO 9	0 TO 150
CLEAR/OFF	10 TO 11	0 TO 150

### Oven Sensor and Sensor Circuit:

The control monitors the oven temperature through the oven temperature sensor. The sensor on these models is located on the rear oven wall just right of center just below the broil unit.

### Oven Sensor and Door Switch Ohmmeter Test:

(See "Motorized Door Lock Operation" for door switch function explanation.)

Disconnect power to range. Make resistance measurement from side of sensor & lock switch connector with exposed terminals.

Circuit	Terminals	Ohms
Oven Sensor	4 to 6	*1100 @ Room Temp. 2600 @ Clean Temp.
Door Unlatched	3 to 1	0
Door Latched	3 to 2	0

### SENSOR AND LOCK SWITCH CONNECTOR

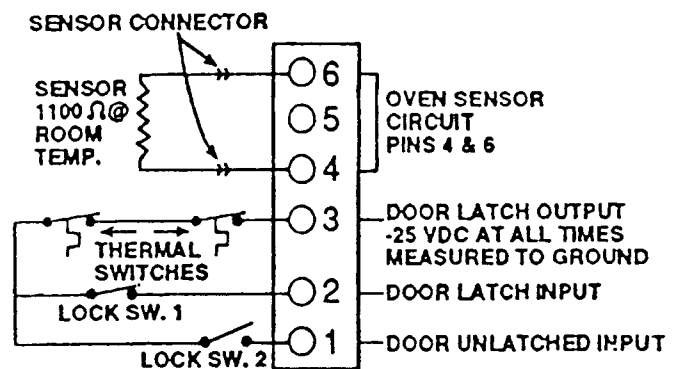

- If abnormal reading is observed, remove sensor from oven and check at disconnect block

## ERC FAILURE CODES

FAILURE CODE	MEANING	CORRECTION
-F1- -F7-	Stuck Key	Determine if problem is with the Key Panel or the Control by: 1. Pushing CLEAR / OFF pad 2. Disconnecting Ribbon Cable from control and waiting at least 32 seconds see if Code reoccurs. If code reoccurs, problem is in the Control. If code does not reoccur the problem is with the key panel.
-F2-	Oven Over Temperature Exceeded 590° with door in unlocked position or 990° with door locked Remember: ERC measures resistance of sensor circuit, not actual oven temp. During Clean Operation	If actual over temperature condition did occurred: <ul style="list-style-type: none"> <li>Look for welded relay contacts.</li> </ul> If over temperature condition did not occur: <ul style="list-style-type: none"> <li>Look for a high resistance connection or any other cause of high resistance in the sensor circuit.</li> <li>Open thermal switch( self - resetting) located on floor of component compartment . Switch is normally closed and will open if area overheats due to inoperative cooling fan. Check Fan Operation.</li> <li>Both Lock Sw. #1 and #2 closed at same time.</li> </ul>
-F3- -F4-	Open Sensor Circuit or Shorted Sensor Circuit	1. Measure Sensor Circuit Resistance at Sensor / Lock Switch connector plug at ERC (should read approx. 1100Ω @ room temp.). Measure lead to lead and each lead to chassis ground. 2. Measure resistance directly across sensor (pull sensor leads into oven approx. 10" and cut leads at crimp connection and check sensor resistance). <ul style="list-style-type: none"> <li>Both sensor leads shorted to ground.</li> <li>Cut or pinched sensor harness wire.</li> <li>Loss of contact within sensor harness connector at back of oven or ERC.</li> </ul> If Circuit Appears Normal: (approx. 1100Ω) <ul style="list-style-type: none"> <li>Reinstall sensor disconnect plug on ERC and measure sensor resistance from connector pin solder joints on back of ERC circuit board. If circuit is open problem is in the connector plug. Remove terminals from connector block and bend them to restore contact pressure.</li> </ul>
-F8- -FF-	Component failure within ERC affecting temperature processing circuits	Replace Control
-F9-	Problem with Door lock circuit such as pinched wire between ERC & door lock switch (lock switch # 1).	Check wiring and test operation of switch

NOTE: Connections can be intermittent due to a corrosive build up between the connection to the terminals, by being bent by the insertion of a probe, ETC.



## 30" Built - In Wall Oven

### ERC Convection Oven Control with Motorized Lock System:

The Convection Electronic Touch Control is SIMILAR to ERCII control used on 30" built - in wall oven. The control system consists of the Electronic Control, Key Panel, Sensor and Sensor circuit, Motorized Door Latch Mechanism, and Door Lock Circuit. The control has the following features:

BAKE, BROIL (HI & LO), CONVECTION BAKE, CONVECTION ROAST, COOK TIME, STOP TIME, TEMPERATURE PROBE, CHILD LOCKOUT, CLOCK AND TIMER.

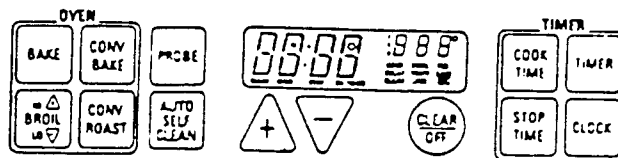

### Control Operation:

#### Power Up or After Power Failure:

All segments of the display will light for about 5 seconds, then last set time of day will flash in display until the clock is set or another function is used.

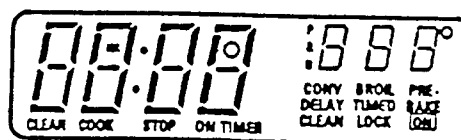

#### + / - (Increase / Decrease) Pads:

The following outlines the functions of the pads:

- Used to select Time, Temperature, Start & Stop Times, HI/LO Broil, etc.
- Pads will not function unless one of the program pads are touched first.
- No audible tone when touched.
- Used to initiate programs. If not touched within 20 seconds after program selection will default to time of day.

**NOTE:** + / - pad speed can be changed by pressing and holding + / - and timer pads for 2 to 3 seconds. A number between 1 & 5 will be displayed. 1 being slowest and 5 being fastest.

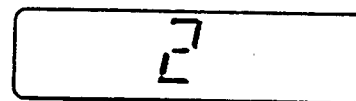
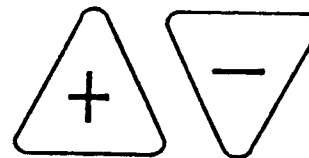

#### To Set Clock:

1. Touch Clock pad
2. Press + / - pad to set time of day.
3. Press clock pad again to lock numbers in or they will automatically lock in after one minute.

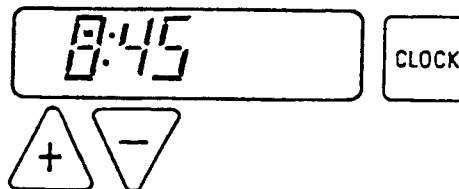

## 30" Built - In Wall Oven

### To Set Timer:

The Timer does not control any oven operations. Maximum Timer setting 9 hours and 55 minutes.

1. Touch Timer pad
2. Press + / - pads to select desired time.  
Timer will automatically start.

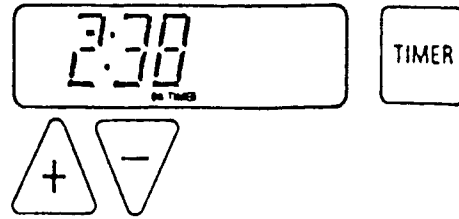

When the Timer reaches the last minute during the count down the display will change to seconds and a single beep will sound. At the end of the cycle the timer will signal and change to 00. Press timer pad or clear off pad to return to time of day.

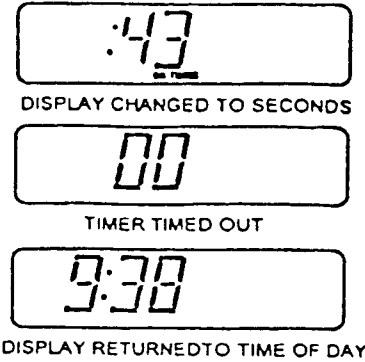

### END OF CYCLE TONE:

At the "END" of a cycle the control will "BEEP" 3 times followed by a signal tone every six seconds until canceled.

The tone every six seconds can be eliminated by pushing and holding the CLEAR / OFF pad for 10 seconds.



### CHILD LOCKOUT FEATURE:

The Control Has The Provision To Lock The Control Panel To Prevent The Oven From Being Used.

To Lock Control Panel - Press and hold + / - pads along with STOP TIME pad for approximately 2 seconds. The word "OFF" will appear in display and then disappear. Anytime a oven function pad is pressed the word "OFF" will appear in display.

Repeat above procedure to unlock control.

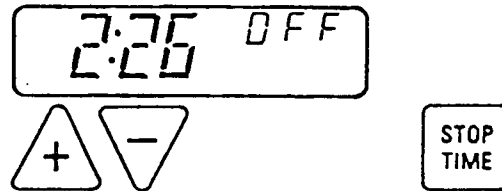

### BAKE OPERATION:

1. Touch Bake Pad.
  - Control will "BEEP", \_\_\_° and SET Bake will appear in Display.
2. Press + / - Pad.
  - Previous bake temperature will be displayed.
  - At initial power up or after power failure 170°F will be displayed.



## 30" Built - In Wall Oven

3. Select desired temperature using Increase / Decrease pads.
  - After about 5 seconds the bake relay will close and display will show 100° and ON.

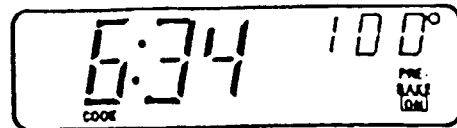

### TO TIME BAKE:

1. Touch COOK TIME pad
  - 0HR:00 and oven on time will flash
2. Press + or - Pad for desired length of baking time.
3. Touch BAKE pad and select desired temperature.
  - Same procedure as bake.



### TO SET DELAY START:

1. Touch COOK TIME pad and select length of cooking time
2. Press STOP TIME pad
  - Stop Time will flash in display.
3. Press + / - pad until desired stop time appears in display.
4. Touch Bake and select Temperature.
  - Same procedure as bake.

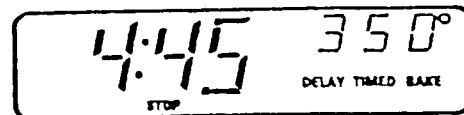

### TEMPERATURE PROBE OPERATION:

1. Plug Probe into receptacle.
2. Touch PROBE PAD.
  - SET PROBE —° will appear in display.
3. Press + / - pad and select probe temperature.
  - Display will show "LO" until 100°F probe temperature is reached.
  - Control will track temperature until set temperature is reached.
  - Oven will signal and turn "OFF".
4. Touch Bake pad and select oven temperature.

Probe Temperature Range is 100° to 200°F.



### TO BROIL:

1. Open door to broil stop.
2. Touch BROIL pad.
  - SET — with the word broil will appear in display.
3. Press + pad for HI (550°F) or - pad for LO (450°F) Broil.
  - LO or HI and "ON" will be displayed.



## 30" Built - In Wall Oven

### BAKE TEMPERATURE CALIBRATION:

The bake temperature can be adjusted by  $\pm 35^{\circ}$  F. from the factory setting.

#### To Adjust The Bake Temperature:

1. Press BAKE pad.



2. Select any temperature above  $500^{\circ}$  F. by pressing the + pad.

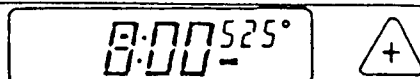

3. Immediately Press and Hold BAKE pad until "00" or previously entered temperature is displayed.



4. Press the + or - pad to change the oven temperature  $+35^{\circ}$  or  $-35^{\circ}$  in  $5^{\circ}$  steps.

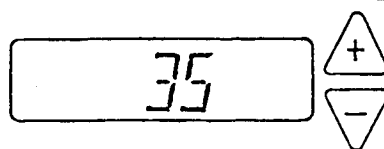

5. Press CLEAR / OFF pad to return to normal operation.



### Clean Operation:

1. Touch CLEAN pad

- --- SET CLEAN TIME in display.

2. Press + / - pad.

- CLEAN and 3HR: 00 will be displayed and door will lock.

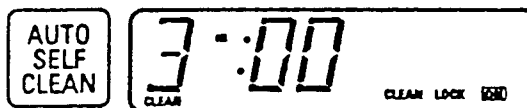

**NOTE:** Clean time can be varied between 2 and 4 hours in 5 minute intervals.

3. When the word lock disappears from the display the door will unlock.

### CONVECTION COOKING:

Convection cooking is the movement of heated air in the oven cavity. This is accomplished by a fan mounted on the rear wall of the oven cavity. This fan operates anytime one of the convection cooking modes is selected and the oven door is closed. This provides for a more even heat distribution during the cooking operations. As a result of even heat distribution food browns more evenly and temperatures can be reduced by as much as  $25^{\circ}$ F for some foods. Cooking times of more than 15 minutes do not require preheating of the oven.

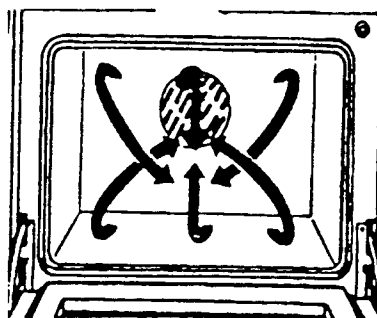

## 30" Built - In Wall Oven

### When To Use Convection Bake Or Convection Roast:

#### CONVECTION BAKE

- Ideal for bake foods when more than one shelf is being used.
- Large quantities of baked foods.
- Cookies, biscuits, muffins cupcakes, ETC.

#### CONVECTION ROAST

- Large tender cuts of meat uncovered.
- Roasting pans with low sides to allow air movement around food.

#### TO CONVECTION BAKE:

1. Place the food in the oven making sure pans do not touch.
2. Touch Convection Bake Pad.
  - SET ---° and CONV BAKE will appear in Display.
3. Touch + or - Pad.
  - Previously baking temperature will appear.

**NOTE:** At initial power up or after power failure 170°F will be displayed.

4. Select desired temperature using + or - Pad.
5. "ON" appears in display. After 25 to 30 seconds the word SET will disappear from display and Selected Temperature will change to oven temperature and begin rising in 5° increments until selected temperature is reached. Display will show 100°F until oven reaches 100°F.



#### CONVECTION ROAST:

1. Place the food in the oven making sure pans do not touch.
2. Touch Convection Roast Pad.
  - SET ---° and CONV will appear in Display.
3. Same procedure as Convection Bake.

#### CONVECTION OVEN CONTROL SYSTEM:

The oven control system consists of Key Panel Assembly, Relay and Control Board Assembly, Control Transformer, Sensor, Sensor Circuit, Lock Motor and Lock Circuit.

# 30" Built - In Wall Oven

## Control:

The Oven Control is made up of the smart board and relay board mounted in a housing. The Relay Board consists of 6 relays, (Bake, Broil, Conv Bake, Lock Motor, Conv Fan and Oven Light), a series of 1/4" terminals, Control Transformer Connector and Sensor, Meat Probe and Lock switch Connector along with Key Panel Ribbon Connector.

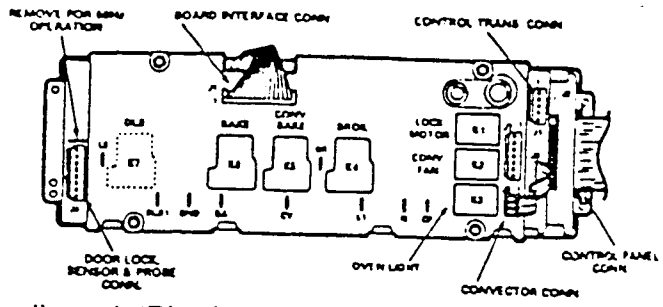

**NOTE:** Convection Connector must be properly aligned (Pin 1 to Pin 1) to avoid damage to control.

## CONTROL VOLTAGES:

Terminals / Connector	Voltage and Mode of Operation
L1 to BA *	240 VAC when oven is not calling for heat
L1 to BR *	240 VAC when oven is not calling for heat
L1 to CV *	240 VAC When Oven Is Not Calling For Heat
L1 to CF **	Approx. 120 VAC with oven door closed
Lock Motor Connector J7 Pin 1 to N	120 VAC when lock motor is locking or unlocking.
Oven Light Connector J7 Pin 7 to N	Oven Light is on any time relay is closed or oven door is open.

\* **NOTE:** If 0 or 120 VAC is read, press CLEAR / OFF and recheck. If 240 VAC is not present check BA to N, BR to N and CV to N (should read 120VAC). If 120 VAC is not present check wiring. \*\*If 120 VAC is not present check door frame switch.

## CONTROL TRANSFORMER:

The Control Transformer is a separate component from the electronic control and is mounted on the lower left center of the range body back (Near bake unit terminals). The Primary and Secondary voltages, coil resistance and connector pins are shown in the diagram.

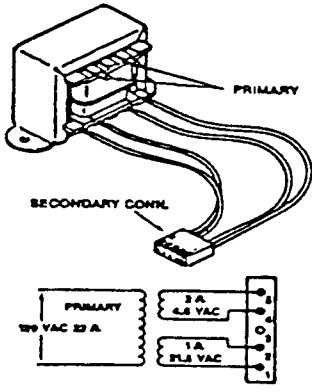

30" Built - In Wall Oven

Oven Circuits:

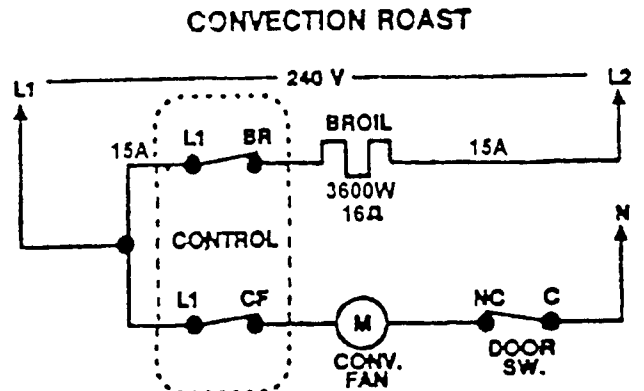
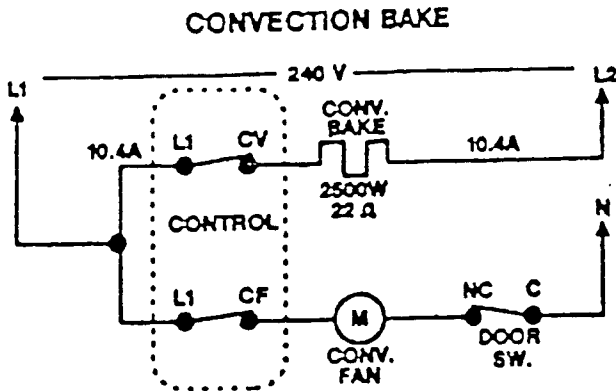
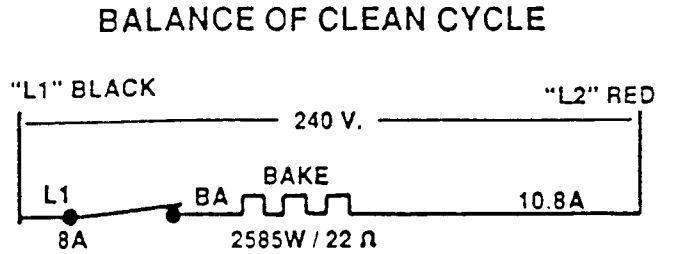
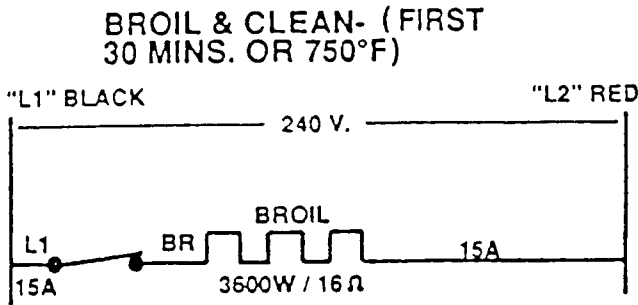
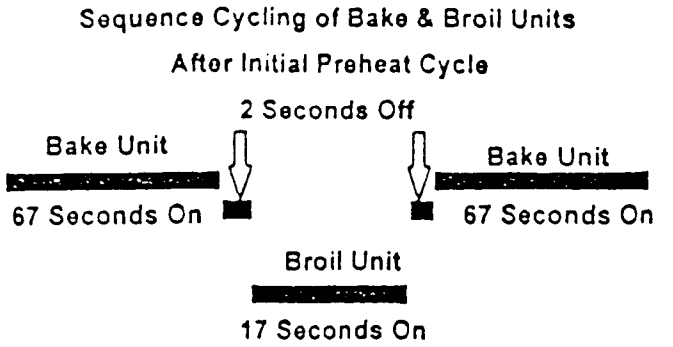
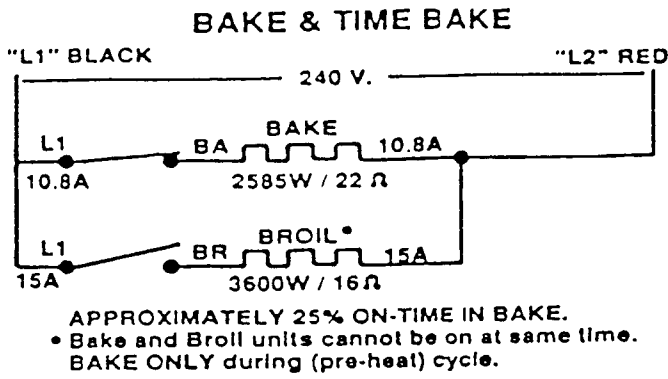

**Key Panel:**

The key panel is connected to the control by a ribbon connector. The control will sound a tone when any of the pads are depressed except for the +/- pads.

To help isolate a problem to either the control or key panel, depress each pad on the key panel and observe the following:

- Bake, Broil, Convection Bake, Convection Roast, Clean, Timer, Clock, Stop Time, and Cook Time Modes - Audible tone plus display showing mode of operation selected.
- Clear / Off - Audible tone and display shows time of day.
- Probe - Audible tone if probe has been plugged in and probe pad is depressed.
- Oven Light - When oven light pad is depressed the only sound will be the relay operation.
- +/- Pads - No audible tone. Can only be used after another function pad has been selected.

If some of the pads work and some don't, the problem is probably with the key panel. To verify that the key panel is the problem check the connector for proper insertion of the ribbon cable and perform the Ohm Test. If the ohmmeter reads  $\infty \Omega$  when depressing the pad or shows some resistance without depressing the pad the key panel is bad.

**Ohmmeter Test:**

Set ohmmeter on scale that will read approximately  $500\Omega$ . Connect leads to ribbon cable as indicated in chart for each function. Depress function pad. Meter should read less than  $\infty \Omega$  if the switch contact is working.

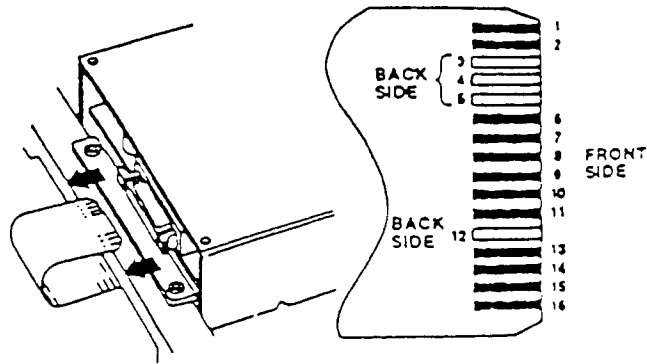

FUNCTION	CONDUCTORS	FUNCTION	CONDUCTORS
BAKE	3 - 8	TIMER	3 - 9
BROIL	4 - 8	CLOCK	4 -
CLEAN	5 - 8	STOP TIME	5 - 9
CLEAR/OFF	1 - 12	COOK TIME	6 - 9
CONV. BAKE	6 - 8	OVEN LIGHT	5 - 10
CONV. ROAST	7 - 8	DOWN ARROW	16 - 15
PROBE	3 - 10	UP ARROW	16 - 14

**Oven Sensor and Sensor Circuit:**

The control monitors the oven temperature through the oven temperature sensor. The sensor on these models is located on the rear oven wall just right of center just below the broil unit.

**Oven Sensor & Door Switch Ohmmeter Test:**

(See "Motorized Door Lock Operation" for door switch function explanation.)

Disconnect power to range. Make resistance measurement from side of sensor & lock switch connector with exposed terminals.

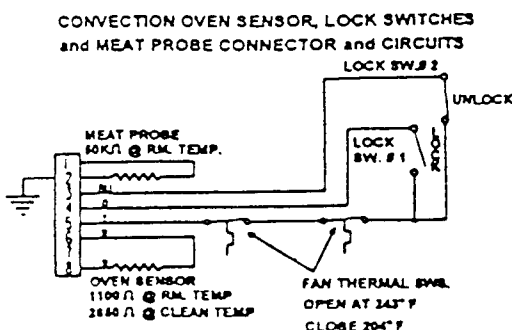

Circuit	Terminals	Ohms
Oven Sensor	6 to 8	*1100 @ Room. Temp. 2600 @ Clean Temp.
Door Unlatched	3 to 5	0
Door Latched	4 to 5	0

\*If abnormal reading is observed, remove sensor and check at disconnect block.



## 30 Built - In Wall Oven

FAILURE CODE	MEANING	CORRECTION
-F1- -F7-	Stuck Key	Determine if problem is with the Key Panel or the Control by 1. Pushing CLEAR / OFF pad 2. Disconnecting Ribbon Cable from control and waiting at least 32 seconds see if Code reoccurs. If code reoccurs, problem is in the Control If code does not reoccur the problem is with the key panel
-F2-	Oven Over Temperature Exceeded 590° with door in unlocked position or 990° with door locked Remember: ERC measures resistance of sensor circuit, not actual oven temp. During Clean Operation	If actual over temperature condition did occurred. • Look for welded relay contacts. If over temperature condition did not occur: • Look for a high resistance connection or any other cause of high resistance in the sensor circuit.  • Open thermal switch( self - resetting) located on floor of component compartment . Switch is normally closed and will open if area overheats due to inoperative cooling fan. Check Fan Operation. • Both Lock Sw. #1 and #2 closed at same time.
-F3- -F4-	Open Sensor Circuit or Shorted Sensor Circuit	1. Measure Sensor Circuit Resistance at Sensor / Lock Switch connector plug at ERC (should read approx. 1100W @ room temp.). Measure lead to lead and each lead to chassis ground. 2. Measure resistance directly across sensor (pull sensor leads into oven approx. 10" and cut leads at crimp connection and check sensor resistance). • Both sensor leads shorted to ground. • Cut or pinched sensor harness wire. • Loss of contact within sensor harness connector at back of oven or ERC. If Circuit Appears Normal: (approx. 1100W) • Reinstall sensor disconnect plug on ERC and measure sensor resistance from connector pin solder joints on back of ERC circuit board. If circuit is open problem is in the connector plug. Remove terminals from connector block and bend them to restore contact pressure.
-F8- -FF-	Component failure within ERC affecting temperature processing circuits	Replace Control
-F9-	Problem with Door lock circuit such as pinched wire between ERC & door lock switch (lock switch # 1).	Check wiring and test operation of switch
-Fd-	Shorted Meat Probe	Make the following checks: • Make sure J4 Plug is plugged in correct direction and connected to ERC. • Check wiring and probe receptacle for short.

NOTE: Connections can be intermittent due to a corrosive build up between the connection to the terminals, by being bent by the insertion of a probe, ETC.

## 30" Built - In Wall Oven

### Convection Bake Element & Fan Assembly:

The convection Bake Element and Fan Assembly are located on the back wall of the oven liner behind convection bake / fan cover.

### To Access Convection Bake Element & Fan Blade:

1. Disconnect Power To the Oven, remove oven door and oven racks.
2. Remove 4 screws mounting panel to rear wall (2 on each side) and pull forward.

### To Remove Convection Bake Element:

Remove three screws mounting element to back wall and pull forward and disconnect leads.

### To Service Fan Motor:

Fan blade must be removed from inside oven. Remove oven from installation, and remove back cover.

**Note:** When servicing bake unit, broil unit or sensor convection fan cover must be removed.

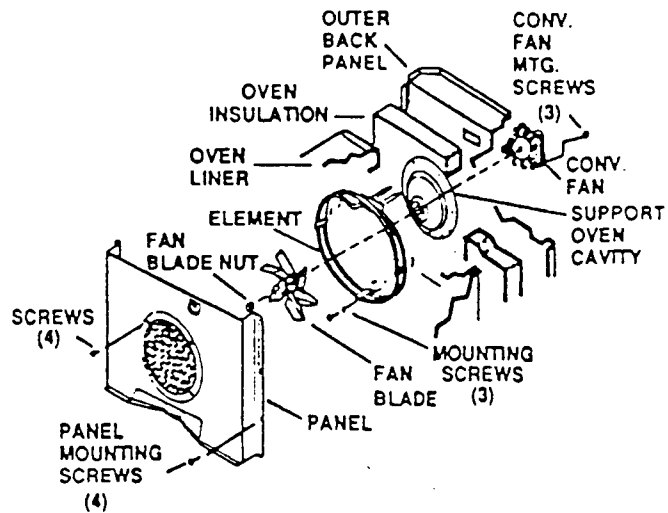

# 30" Built - In Wall Oven

## Motorized Door Lock:

The motorized door lock assembly is located on top right side of oven just below the control. The assembly consists of a lock motor cam and switch assembly, lock hook, and mounting plate.

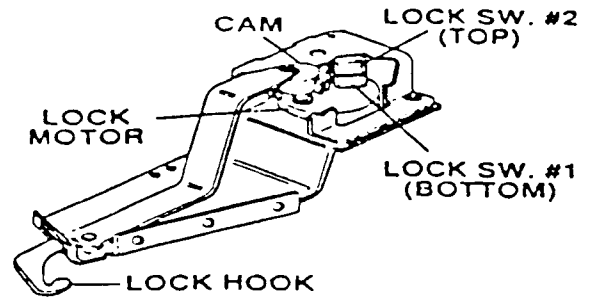

## Motorized Door Lock Operation:

The lock motor is energized when the control is set for Clean and Clean Time selected. The lock relay contacts will close and complete the circuit that supplies the voltage (120VAC) to the lock motor. The motor turns the cam that pulls the hook into the lock position (Hook enters slot in door to prevent the door from being opened).

**NOTE:** Display of Control will flash "DOOR" if the door switch is in the "C" to "NC" position.

DOOR LOCKING / OR UNLOCKING

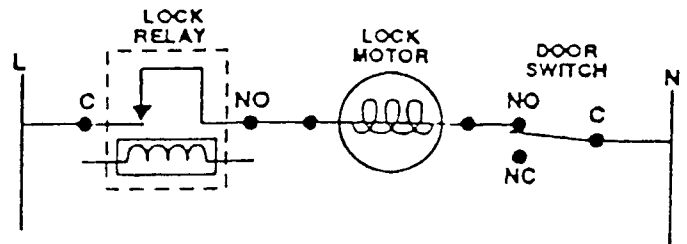

ALL OTHER MODES WITH DOOR CLOSED

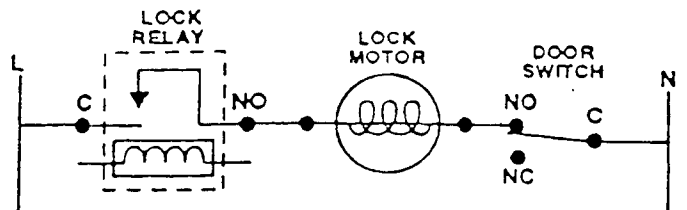

The word "LOCK" will flash on and off in the display while the lock motor is in motion. When the door is locked the word "LOCK" remains illuminated in the display.

**Cam** - The cam on the motor performs two functions:

- Positions the lock hook in the door to prevent opening during clean operation.
- Operates the two lock switches which tells the the control if the door is locked and ready for clean operation.

**Note:** When door is either being locked or unlocked both switches 1 & 2 will be in the open position.

UNLOCKED

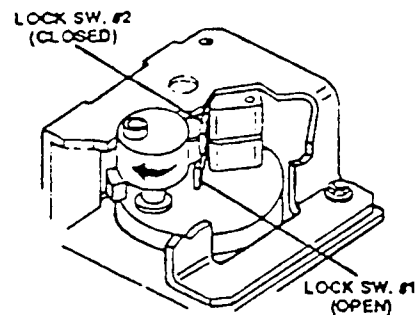

LOCK SW. CIRCUIT

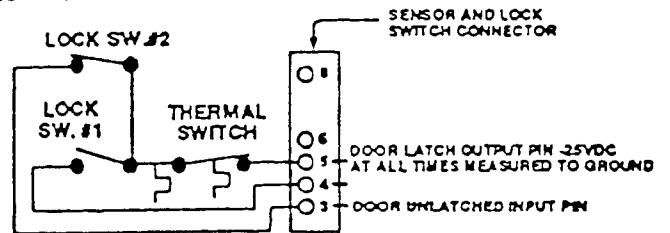

LOCKED

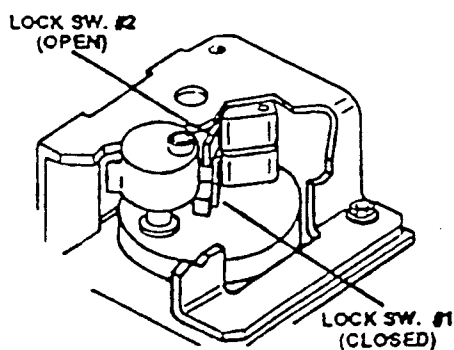

LOCK SW. CIRCUIT

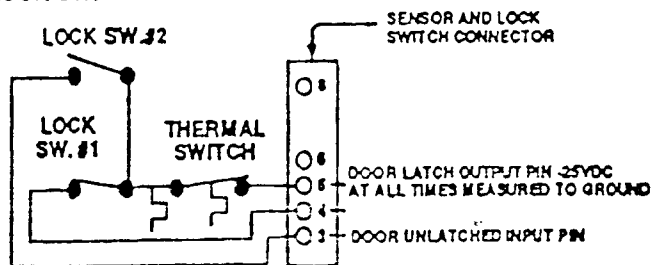

Fan Thermal Switches:

Two fan thermal switch assemblies are located on the floor of the component compartment (one in front of each fan motor). The assemblies consist of a thermal limit switch, resistor and an aluminum plate. If one of the fans fails to operate or perform correctly, the resistor will heat the plate and open the limit switch and turn the oven off.

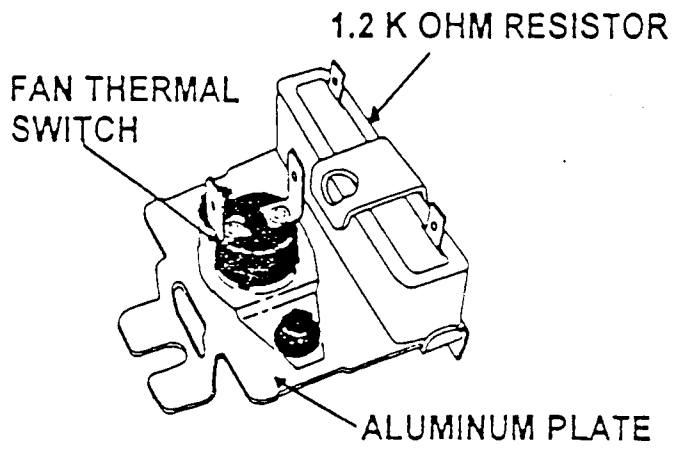
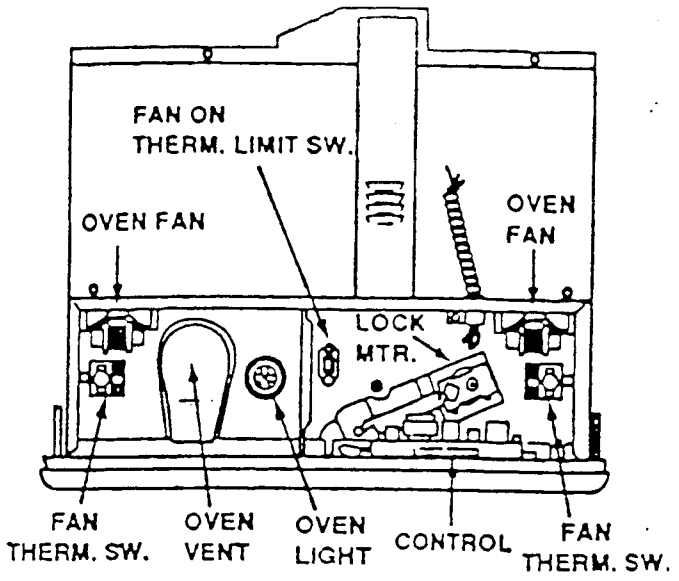

Fan On Thermal Limit Switch:

The fan switch is a resetable type located on the floor of the component compartment. The switch will turn the fan on in any mode of operation when it detects a temperature above 132°F. The fan will turn off once it has cooled below 120°F.

The two 1.2KΩ resistors are wired parallel with the two fan motors. The fan operation keeps the resistors from heating up the aluminum plate and opening one of the fan thermal switches. The fan thermal switches are wired in with the lock motor switches. The Fan Thermal Switches opens at 243°F and closes when temperatures cool below 205°F.

LOCK SW. CIRCUIT

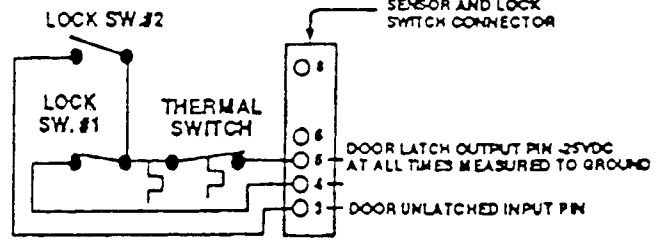

If the fan thermal switch opens during:

- 1 Oven Temperature Below 600°F.
  - a. Bake or Broil - the heating element will cycle "OFF", the lock motor will run and the word lock will appear in display along with the cooking function and temperature. "ON" will disappear from display.
    - If the thermal switch closes while the lock motor is in the unlocking phase of operation the unit will resume cooking.
    - If the thermal switch closes while the lock motor is in the locking phase of operation the program will be cancelled and return to time of day.
  - b. Clean Mode - Program is cancelled when thermal switch opens.

- 2 Oven Temperature Above 600°F
 

Any mode of operation control will go to F-2 failure code. When this condition exists check the fan operation (look for obstructions), inspect oven installation (make sure grill areas are not blocked), oven insulation and lock circuit.

Notes

# SCHEMATIC DIAGRAM

## WARNING

POWER MUST BE DISCONNECTED  
BEFORE SERVICING THE APPLIANCE

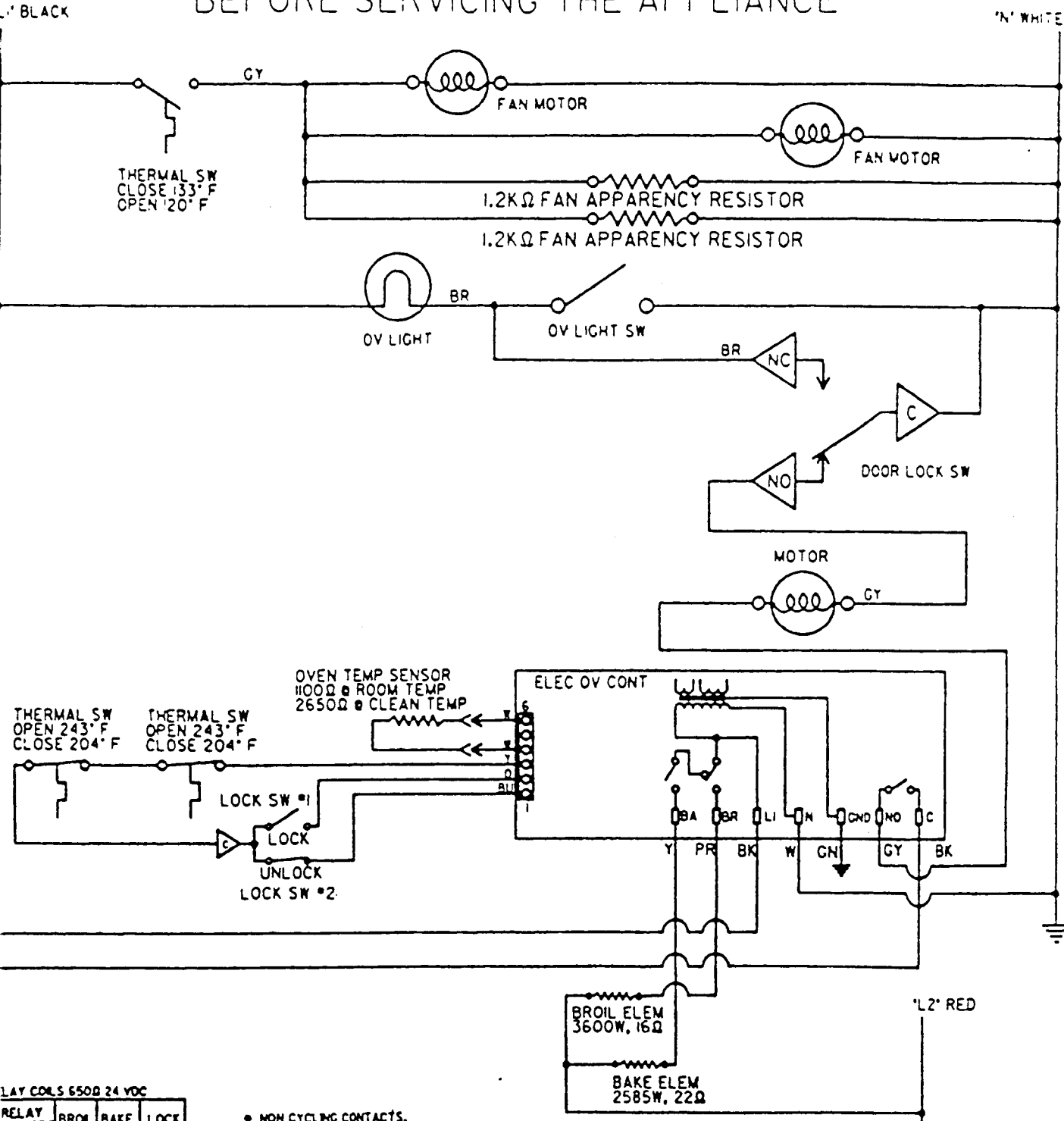

LAY COILS 650D 24 YOC

RELAY CONTACTS MADE	BROIL LI-BR	BAKE LI-BA	LOCK E8-E9
OFF			
BAKE	••	••	
BROIL	••		
CLEAN	•••	•••	X

- NON CYCLING CONTACTS.
- CYCLING CONTACTS.
- IN THE CLEAN CYCLE, BROIL ELEMENT CYCLES FOR THE FIRST 30 MINUTES AND BAKE ELEMENT CYCLES DURING THE REMAINDER OF THE CLEAN CYCLE.
- X CONTACTS MADE AT BEGINNING AND END OF CLEAN CYCLE ONLY.

DOOR	DOOR SW	
	C	NC
OPEN		X
CLOSED	X	
LOCKED	X	

X-CLOSED

# SCHEMATIC DIAGRAM

## WARNING

POWER MUST BE DISCONNECTED BEFORE SERVICING THE APPLIANCE

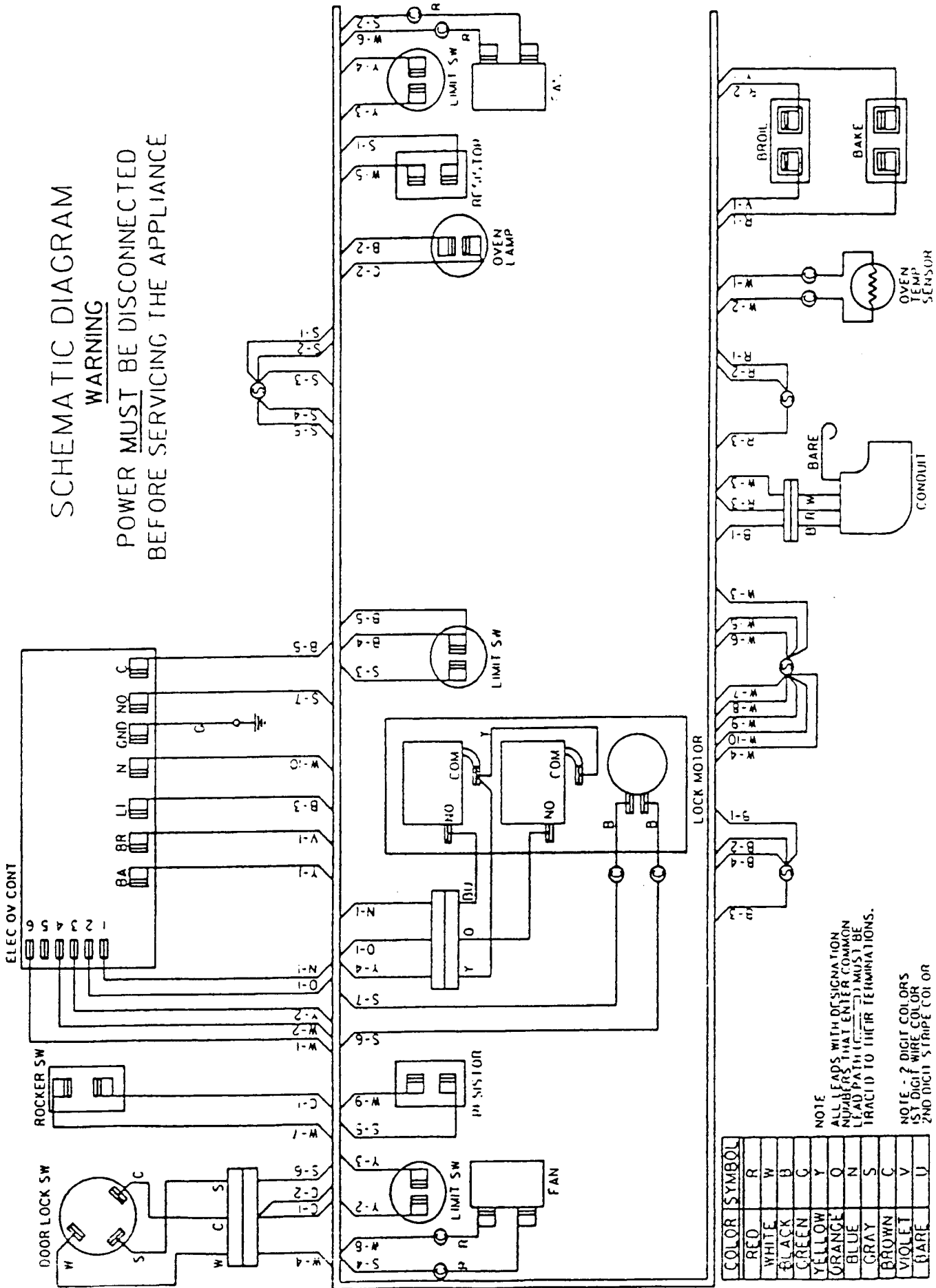

NOTE  
ALL LEADS WITH DESIGNATION NUMBERS THAT ENTER COMMON LEAD PATHS MUST BE TRACED TO THEIR TERMINATIONS.

NOTE - 2 DIGIT COLORS  
1ST DIGIT WIRE COLOR  
2ND DIGIT STRIPE COLOR

COLOR	SYMBOL
RED	R
WHITE	W
BLACK	B
GREEN	G
YELLOW	Y
ORANGE	O
BLUE	N
GRAY	S
BROWN	C
VIOLET	V
NARE	U

30" Built - In Wall Oven

JTP16GT1  
JTP17WT1  
JTP18AT1

# SCHEMATIC DIAGRAM

## WARNING

POWER MUST BE DISCONNECTED BEFORE SERVICING THE APPLIANCE

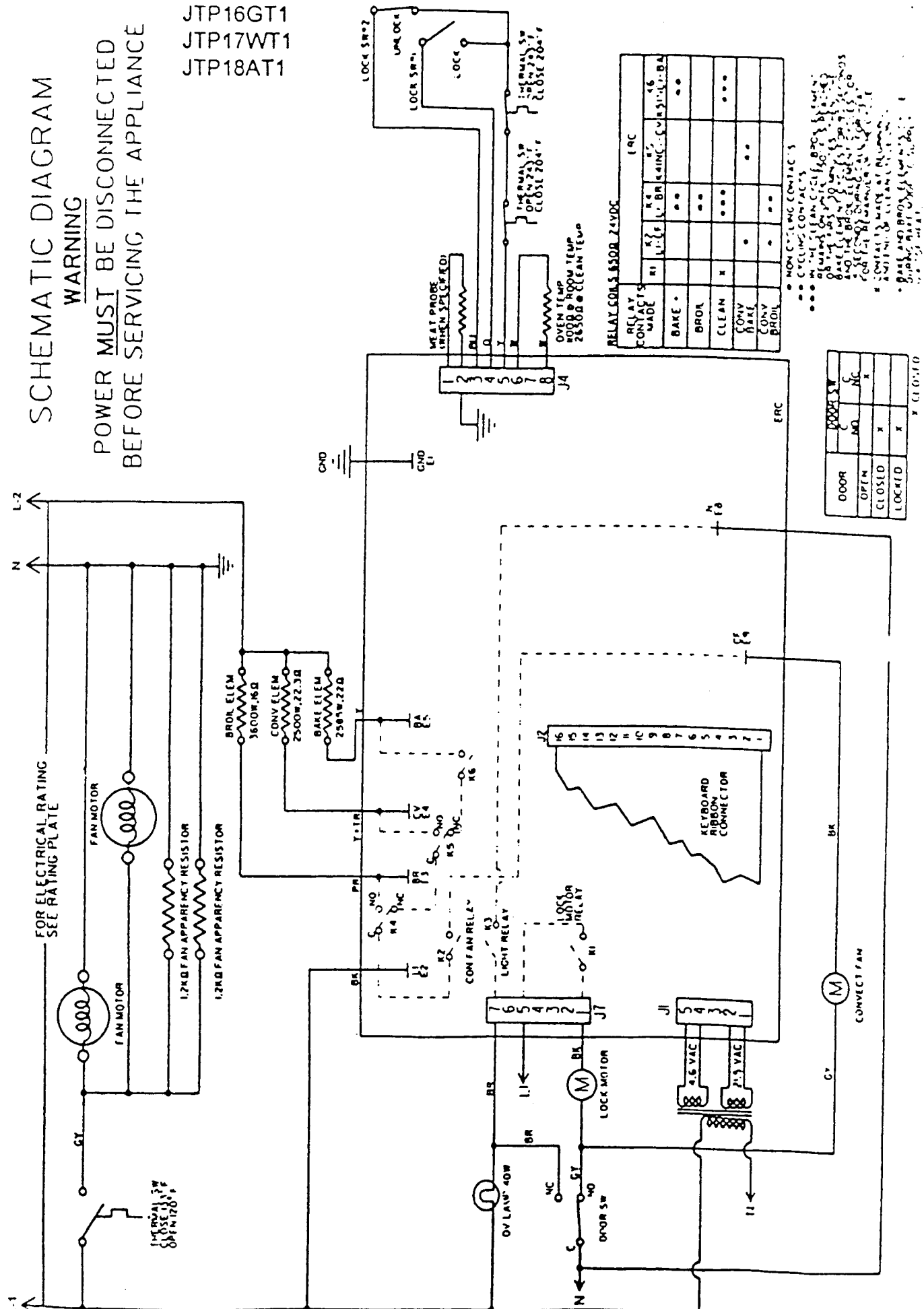

NON CYCLING CONTACTS  
 .. CYCLING CONTACTS  
 .. THE CLEAN CYCLE BPCS SYSTEM  
 OBSERVE THE BPCS SYSTEM  
 BAKE, BROIL, CONV, CLEAN, BAKE  
 AND CONVECTION BAKE  
 FUNCTIONS ALL USE THIS  
 CONTACTS MAKE AT ALL TIMES  
 AND MAKE AT CLEAN CYCLE  
 BAKE AND BROIL FUNCTIONS  
 MAKE AT CLEAN CYCLE BAKE

	DOOR SW	NC
DOOR OPEN	X	
DOOR CLOSED	X	
LOCKED	X	

ERC



30" Built - In Wall Oven  
 JTP16GT1  
 JTP17WT1  
 JTP18AT1

# WIRING DIAGRAM

## WARNING

POWER MUST BE DISCONNECTED  
 BEFORE SERVICING THE APPLIANCE

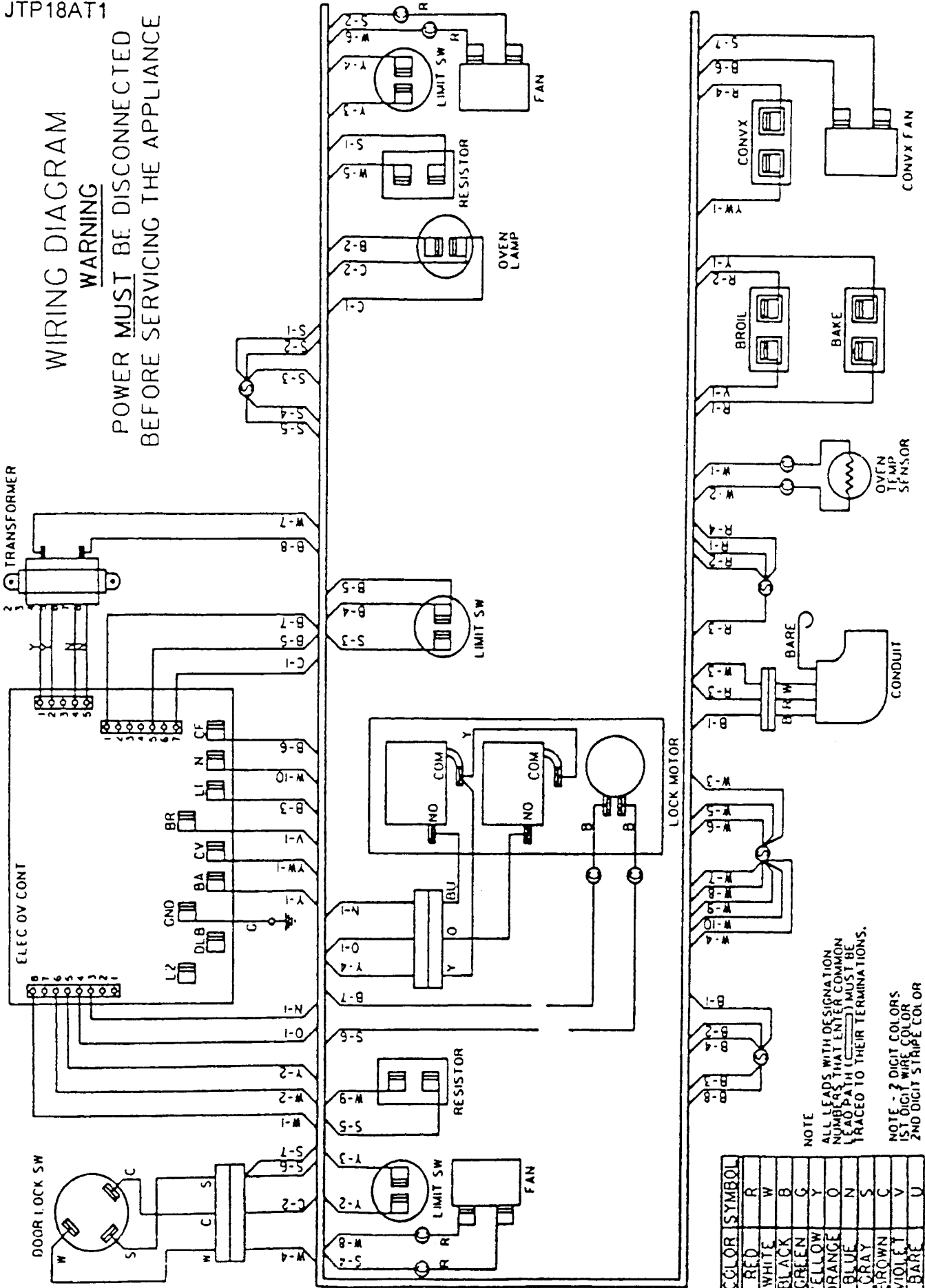

COLOR	SYMBOL
RED	R
WHITE	W
BLACK	B
GREEN	G
YELLOW	Y
ORANGE	O
BLUE	N
GRAY	S
BROWN	C
VIOLET	V
BARE	U

NOTE  
 ALL LEADS WITH DESIGNATION  
 NUMBER 1 THAT ENTER A COMMON  
 LEAD OR COMMON LEAD MUST BE  
 TRACED TO THEIR TERMINATIONS.

NOTE - 3 DIGIT COLORS  
 1ST DIGIT WIRE COLOR  
 2ND DIGIT STRIPE COLOR

