

Service

This manual is to be used by qualified appliance technicians only. Maytag does not assume any responsibility for property damage or personal injury for improper service procedures done by an unqualified person.

Gas Cooktops

This Base Manual covers general information
Refer to individual Technical Sheet
for information on specific models

This manual includes, but is
not limited to the following:

JGD8348CDP
JGC8430BDB/Q/S/W
JGC8645BDB/Q/S/W
JGCP430CDP
JGCP636CDP
JGCP648CDP

Important Information

Pride and workmanship go into every product to provide our customers with quality products. It is possible, however, that during its lifetime a product may require service. Products should be serviced only by a qualified service technician who is familiar with the safety procedures required in the repair and who is equipped with the proper tools, parts, testing instruments and the appropriate service information. **IT IS THE TECHNICIANS RESPONSIBILITY TO REVIEW ALL APPROPRIATE SERVICE INFORMATION BEFORE BEGINNING REPAIRS.**

Important Notices for Servicers and Consumers



WARNING

To avoid risk of severe personal injury or death, disconnect power before working/servicing on appliance to avoid electrical shock.

To locate an authorized servicer, please consult your telephone book or the dealer from whom you purchased this product. For further assistance, please contact:

Customer Service Support Center

CAIR Center

<u>Web Site</u>	<u>Telephone Number</u>
WWW.JENNAIR.COM	1-800-536-6247
CAIR Center in Canada	1-800-688-2002

Recognize Safety Symbols, Words, and Labels



DANGER

DANGER—Immediate hazards which **WILL** result in severe personal injury or death.



WARNING

WARNING—Hazards or unsafe practices which **COULD** result in severe personal injury or death.



CAUTION

CAUTION—Hazards or unsafe practices which **COULD** result in minor personal injury, product or property damage.

Table of Contents

Important Information	2	Disassembly Procedures for Models Listed	18
Safety Information	4	JGD8348CDP	
Safety Practices for Servicer	5	JGCP430ADP	
Servicing	5	JGCP636ADP	
Before Installing	5	JGCP648ADP	
Receiving Cooktop	5	Main Top Removal	18
Unpacking	5	Spark Module Removal	18
Gas Connection	6	Surface Ignitor Removal	18
Electrical Requirements	6	Burner Switch Removal	18
Electrical Connections	6	Manifold Pipe Removal	18
Product Safety Devices	7	Orifice Holder Removal	18
General Information		Burner Tubing Removal	18
Model Identification Rating Label and Ordering		E-Burner Removal	18
Relacement Parts	8	Grease Filter Removal	20
Cooking Nomenclature	8	Blower Removal	20
Specifications	9	Appendix A: Installation Instructions	
Placement of the Cooktop	9	Models JGCP430ADP, JGCP636ADP,	
Do Not Block Air Vents	9	JGCP648ADP	A-2
Location of Model Number	9	Model JGD8348CDP	A-4
Model Identification	9	Ducting Instructions, Model JGD8348CDP	A-6
Service	9	Model JGC8430BD*	A-9
Parts and Accessories	9	Model JGC8645BDS	A-10
Extended Service Plan	9	Appendix B: Use and Care	
Grounding	9	Models JGCP430ADP, JGCP636ADP,	
Cooktop Description	10	JGCP648ADP	B-2
Troubleshooting Procedures	11	Model JGD8348CDP	B-4
Component Testing Information	13	Model JGC8430BD*	B-6
Disassembly Procedures		Model JGC8645BDS	B-8
Disassembly Procedures for Models Listed	16	Care and Cleaning	B-10
JGC8430BDB/W/Q/S		Appendix C: LP/Natural Gas Conversion	
JGC8645BDS		Models JGD8348CDP, JGCP430ADP,	
Main Top Removal	16	JGCP636ADP, JGCP648ADP	C-2
Spark Module Removal Bottom Access	16	Models JGD8430BD*, JGD8645BDS	C-4
Spark Module Removal	16		
Surface Ignitor Removal	16		
Burner Switch Removal	16		
Manifold Pipe Removal	16		
Orifice Holder Removal	16		
Burner Tubing Removal	16		

Safety Information

As with all appliances, there are certain rules to follow for safe operation. Verify everyone who operates the cooktop is familiar with the operations and with these precautions.

Use appliance only for its intended purpose as described. Pay close attention to the safety sections of this manual.

Recognize the safety section by looking for the following symbol or the word safety.

Recognize this symbol as a safety precaution.



WARNING

If the information in this manual is not followed exactly, a fire or explosion may result causing property damage, personal injury or death.

Do not store or use gasoline or other flammable vapors and liquids in the vicinity of this or any other appliance.

WHAT TO DO IF YOU SMELL GAS

- Extinguish any open flame.
- Do not try to light any appliance.
- Do not touch any electrical switch; do not use any phone in your building.
- Immediately call your gas supplier from a neighbor's phone. Follow the gas supplier's instructions.
- If you cannot reach your gas supplier, call fire department.

Installation and service must be performed by an authorized installer, service agency or gas supplier.

WARNING

To avoid risk of electrical shock, property damage, personal injury or death; verify wiring is correct, if components were replaced. Verify proper and complete operation of unit after servicing.

WARNING

This gas appliance contains or produces a chemical or chemicals which are known to the state of California to cause cancer, birth defects or other reproductive harm. To reduce the risk from substances in the fuel or from fuel combustion make sure this appliance is installed, operated, and maintained according to the instructions in this manual.

Due to the nature of cooking, fires can occur as a result of overcooking or excessive grease. Although a fire is unlikely, if one occurs proceed as follows:

Cooktop Fires

1. Do not turn on any ventilation system above the cooktop.
2. Turn all controls to the OFF position.
3. As an added precaution turn off the electricity at the main circuit breaker or fuse box and the gas at the main supply valve.
4. Cover the food or grease to smother fire. If smoke or fire persist call the local fire department.

To avoid the risk of property damage or personal injury do not obstruct the flow of combustion or ventilation air.

To avoid the risk of electrical shock, serious personal injury or death: Make sure your cooktop has been properly grounded and always disconnect the electrical supply before servicing the unit.

NOTE: The maximum gas supply pressure for these models must not exceed 14 inches W.C.P.

Safety Information

Safety Practices for Servicer

Safe and satisfactory operation of gas cooktops depend upon its design and proper installation. However, there is one more area of safety to be considered:

Servicing

Listed below are some general precautions and safety practices which should be followed in order to protect the service technician and consumer during service and after service has been completed.

1. **Gas smell**—Extinguish any and all open flames and open windows.
2. **Turn gas off**—Service cooktop with gas turned off unless testing requires it.
3. **Checking for gas leaks**—Never check for leaks with any kind of open flame. Soap and water solution should be used for this purpose. Apply solution to suspected area and watch for air bubbles which indicates a leak. Correct leaks by tightening fittings, screws, connections, applying approved compound, or installing new parts.
4. **Using lights**—Use a hand flashlight when servicing cooktops or checking for gas leaks. Electric switches should not be operated where leaks are suspected. This will avoid creating arcing or sparks which could ignite the gas. If electric lights are already turned on, they should not be turned off.
5. **Do not smoke**—Never smoke while servicing gas cooktops, especially when working on piping that contains or has contained gas.
6. **Check cooktop when service is completed**—After servicing, make visual checks on electrical connection, and check for gas leaks. Inform consumer of the condition of cooktop before leaving.
7. **Adhere to all local regulations and codes when performing service.**

Before Installing

Installing the gas cooktop in compliance with local electrical and gas building codes results in proper operation and consumer satisfaction with the cooktop.

Receiving Cooktop

Inspect cooktop thoroughly at time of delivery. Immediately report any visible damage to carrier. Damage not discovered until after accepting delivery can still be claimed by using a concealed damage report form, available from the carrier's agent.

All shipments, i.e., complete cooktop or parts, are shipped at the buyer's risk. Maytag's responsibility ends when the consignment is accepted by the carrier in "good order." Maytag supports damage claims by supplying invoices, bills of lading, and other documentation as needed. Providing this assistance, however, does not imply any responsibility for settling claims. Do not deduct claims for loss or damage from the invoice and do not withhold payment pending adjustment of claims. Do not return any units or parts for credit without written consent.

Unpacking

- Open the carton and slide cooktop out of packing.
- Remove all literature packed with the cooktop and place cooktop onto a protective flat surface.
- Avoid countertop damage by NOT sliding cooktop across the countertop.
- Remove grates, burner caps, and pressure regulator from the carton.



WARNING

Do not store items of interest to children in cabinets above cooktop. Children may climb on cooktop to reach these items and become seriously injured.

Safety Information

Gas Connection

Verify the cooktop installation meets local codes or current American Gas Association (CGA) requirements in the absence of local codes. When installing CGA units, verify that installation meets local codes or in absence of local codes, current Natural Gas Installation Code CAN/CGA-B149.1 or current Propane Installation Code, CAN/CGA-B149.2 before connecting to the gas supply system.

Installation in manufactured homes must conform with the standard CAN/CSA-Z240 Mobile Homes, Manufactured Home Construction and Safety Standards, Title 24CFR, Part 3280, or with local codes is applicable.

WARNING

To avoid risk of personal injury or property damage. Use only new flexible connectors design certified by AGA or CGA. Do not reuse an old connector. Do not reuse an old connector when moving the appliance.

Access to Gas Connection

Install manual shut-off valve in an accessible location outside the cooktop. Be aware of the location of the shut-off valve. Shut-off valve is not supplied with the cooktop.

Use a pipe joint compound resistant to the action of propane gas on all male threads.

Connect the gas supply line either using hard piping or a properly-certified flexible connector. The pressure regulator supplied with cooktops have a 1/2 inch NPT female connection. Check local codes before choosing a method.

WARNING

Do not over tighten the fitting on the pressure regulator. Overtightening may crack the regulator.

Electrical Requirements

120-volt, 60 Hertz, 20 amp, individual circuit which is properly grounded, polarized and protected by a circuit breaker or fuse.

Electrical Connections

Models with automatic pilotless (spark) ignition require an external electrical source that must be grounded and polarized in accordance with local codes. use National Electrical Code, ANSI/NFPA No. 70-Latest Edition in the absence of local codes.

The wall receptacle must be placed within easy reach of the power cord without interfering with the gas supply line

Cooktops must be properly grounded. Cooktop power cords are equipped with a three-prong ground plug. They fit standard three-prong wall receptacles.

WARNING

To avoid risk of electrical shock or property damage. Do not cut or remove the third (ground) prong from the power cord.

The consumer is responsible for replacing any standard two-prong wall receptacle with a grounded and polarized three-prong wall receptacle. A qualified electrician should check any receptacle the customer doubts is properly grounded. The wiring diagram is on the bottom of the cooktop.

Safety Information

Product Safety Devices

Safety devices and features have been engineered into the product to protect consumer and servicer. Safety devices must never be removed, bypassed, or altered in such a manner as to defeat the purpose for which they were intended. Listed below are various safety devices together with the reason each device is incorporated in the gas ranges.

Pressure Regulator

Maintains proper and steady gas pressure for operation of oven controls. Regulator must be set for the type of gas being used **Natural** or **LP**. After servicing regulator, make certain it is set properly before completing service.

Gas Burner Orifices

Universal orifices are used on most valves. They must be adjusted or set for the type of gas being used **Natural** or **LP**. After servicing a valve or orifice verify it is adjusted properly before completing service.

Grounded Cooktop Frame

Ground prong on power cord is connected to the frame, usually a green lead fastened by a screw. In addition, any part or component capable of conducting an electric current is grounded by its mounting.

If any ground wire, screw, strap, nut, etc. is removed for service, or any reason, it must be reconnected to its original position with original fastener before the appliance is put into operation again.

Failure to do so can create a possible shock hazard.

General Information

This manual provides basic instructions and suggestions for handling, installing and servicing gas cooktops.

The directions, information, and warnings in this manual are developed from experience with, and careful testing of the product. If the unit is installed according to this manual, it will operate properly and will require minimal servicing. A unit in proper operating order ensures the consumer all the benefits provided by clean, modern gas cooking.

This manual contains information needed by authorized service technicians to install and service gas cooktops. There may be, however, some parts which need further explanation. Refer to the Technical Sheets or toll-free technical support line to receive technical assistance from authorized service technicians.

Model Identification Rating Label and Ordering Replacement Parts

Model numbers are recorded on the rating label. Rating label is located on the bottom of the burner box. Before ordering parts, write down the correct model and serial number from rating label. This avoids incorrect shipments and delays. Please refer to parts reference material when ordering replacement parts.

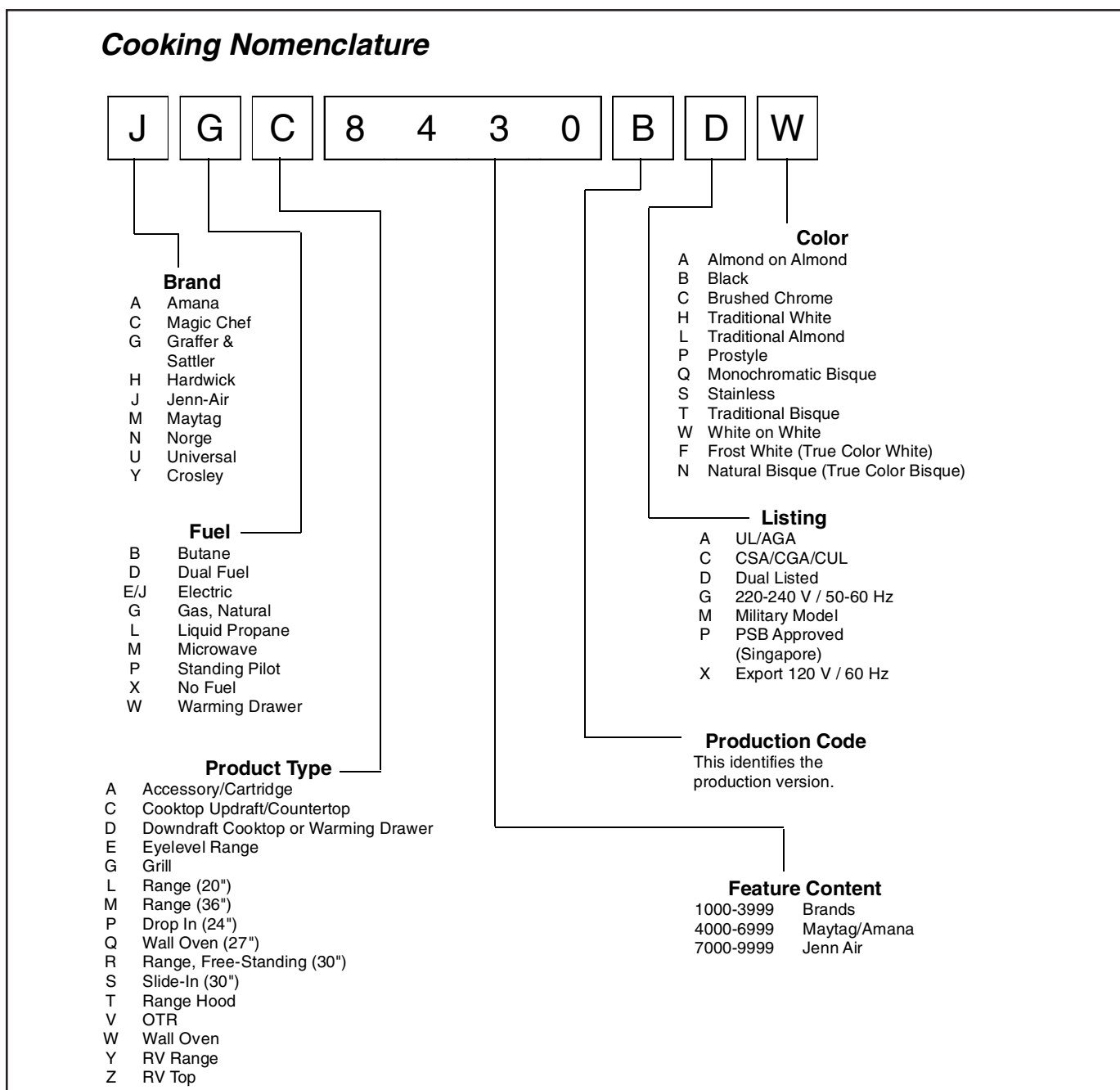

General Information

Specifications

Refer to individual Technical Sheet for specification information.

Placement of the Cooktop

This cooktop must be placed in the kitchen or comparable room. All safety guidelines must be followed and free air flow around the cooktop is essential.

Do Not Block Air Vents

All air vents must be kept clear during cooking. If air vents are covered during operation, the oven may overheat. If this occurs, a sensitive, thermal safety device automatically removes power to the oven, rendering the oven inoperable. The oven will remain in this state until it has sufficiently cooled.

Location of Model Number

To request service information or replacement parts, the service center will require the complete model, serial, and manufacturing number of your cooktop. The number can be found in the burner box. Lift the cooktop surface to view the data.

Model Identification

Complete enclosed registration card and promptly return. If registration card is missing:

- For Jenn-Air product call 1-800-536-6247 or visit the Web Site at www.jennair.com
- For product in Canada call 1-866-587-2002 or visit the Web Site at www.jennair.com

When contacting provide product information located on rating plate. Record the following:

Model Number: _____
Manufacturing Number: _____
Serial or S/N Number: _____
Date of purchase: _____
Dealer's name and address: _____

Service

Keep a copy of sales receipt for future reference or in case warranty service is required. To locate an authorized servicer:

- For Jenn-Air product call 1-800-688-1100 or visit the Web Site at www.jennair.com
- For product in Canada call 1-866-587-2002 or visit the Web Site at www.jennair.com

Warranty service must be performed by an authorized servicer. We also recommend contacting an authorized servicer, if service is required after warranty expires.

Parts and Accessories

Purchase replacement parts and accessories over the phone. To order accessories for your product call:

- For Jenn-Air product call 1-800-688-1100 or visit the Web Site at www.jennair.com
- For product in Canada call 1-866-587-2002 or visit the Web Site at www.jennair.com

Extended Service Plan

We offer long-term service protection for this new oven.

- Dependability PlusSM Extended Service Plan is specially designed to supplement Jenn-Air's strong warranty. This plan covers parts, labor, and travel charges.
Call 1-800-925-2020 for information.

Grounding

NOTE: This appliance must be properly grounded, for personal safety.

Power cord on this appliance is equipped with a three-prong grounding plug. This matches standard three-prong grounding wall receptacle to prevent possibility of electric shock from this appliance.

Consumer should have wall receptacle and circuit checked by qualified electrician to verify receptacle is properly grounded.

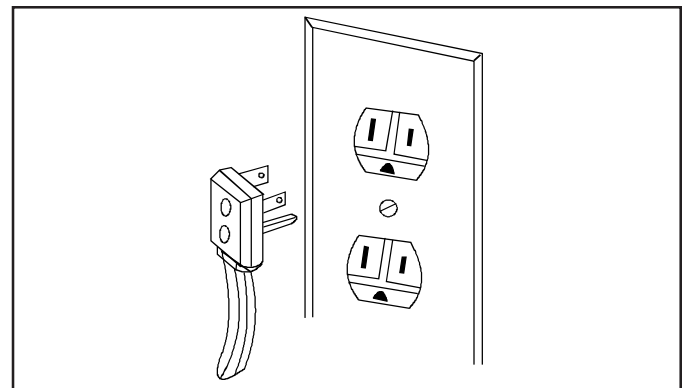

Where standard two-prong wall receptacle is encountered, it is consumers responsibility and obligation to have it replaced with a properly grounded three-prong wall receptacle.

DO NOT, UNDER ANY CIRCUMSTANCES, CUT OR REMOVE THE THIRD (GROUND) PRONG FROM POWER CORD.

General Information

For 15 amp circuits only. Do not use an adapter on 20 amp. circuit. Where local codes permit, a TEMPORARY CONNECTION may be made to properly grounded two-prong wall receptacle by the use of a UL listed adapter available at most hardware stores.

Larger slot on adapter must be aligned with larger slot in the wall receptacle to provide proper polarity.

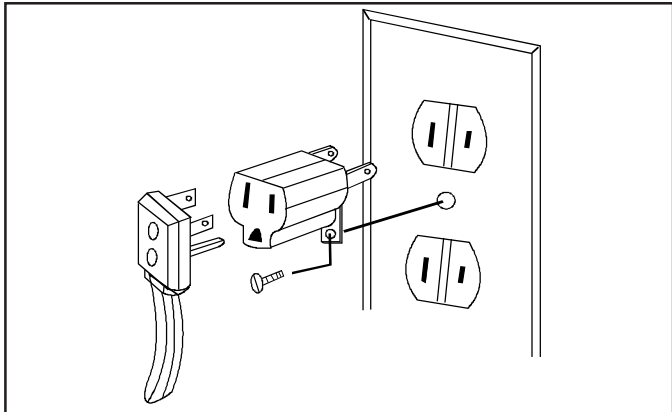

! WARNING

Attaching adapter ground terminal to wall receptacle cover screw does not ground appliance unless the cover screw is metal and not insulated, and wall receptacle is grounded through the house wiring. Consumer should have circuit checked by a qualified electrician to verify receptacle is properly grounded.

When disconnecting power cord from adapter, always hold adapter with one hand. If this is not done, adapter ground terminal is very likely to break with repeated use. Should this happen, DO NOT USE appliance until a proper ground has been established.

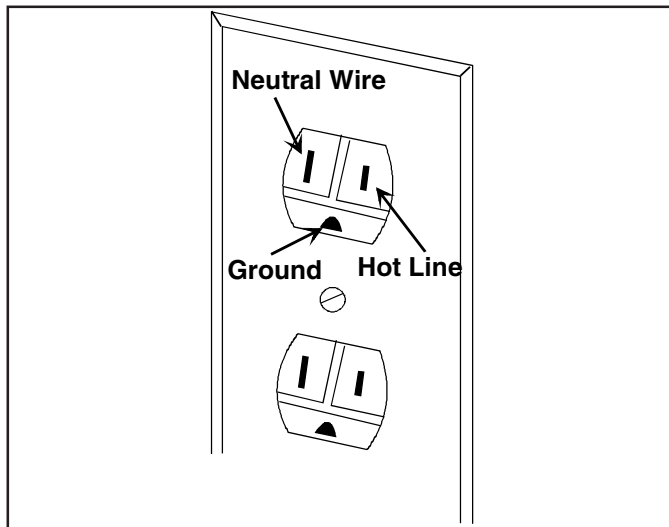

NOTE: Circuit tester can be use to verify voltage is present at the outlet, connect one lead to hot line and the other lead to ground, circuit tester should light.

Cooktop Description

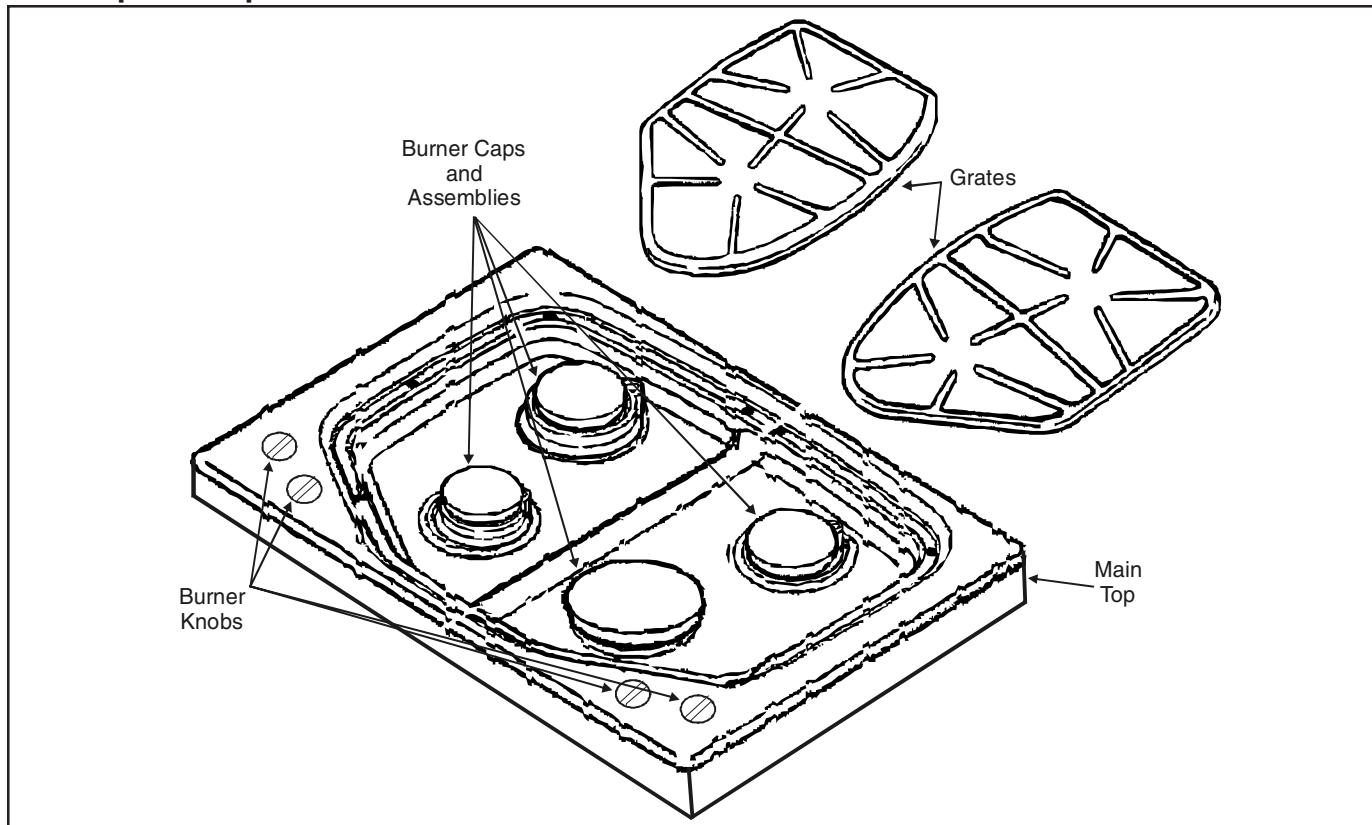

Troubleshooting Procedures



WARNING

To avoid risk of electrical shock, personal injury or death; disconnect power and gas to cooktop before servicing, unless testing requires power and/or gas.



CAUTION

- Verify proper grounding before checking for trouble.
- Be careful of any high voltage circuit.
- Do not touch any part of the circuit on the printed circuit board, since static electric discharge may damage the control panel. Always touch ground while working on this panel to discharge the static electricity, which may be resting on your body.

Problem	Possible Cause	Correction
Burners will not ignite; no spark at top burner.	Poor ground on burner cap Weak or failed spark module Low gas pressure	<ul style="list-style-type: none"> • Clean burner cap. • Replace spark module. • Verify pressure 5" WCP for natural, 10" WCP for LP.
Burner will not ignite. No spark to burner ignitors when burner knob is rotated to "LITE" position.	No 120 VAC to range Micro switch contacts not closing Faulty wiring. Bad connection at burner electrode and electrode socket Inoperative spark module Electrode dirty. Burner cap dirty Cracked or broken electrode, electrode wire or electrode socket	<ul style="list-style-type: none"> • Verify voltage at wall outlet. • Check wiring against appropriate wiring diagram. Verify all terminals and connections are correct and tight. Check micro switch contacts. • Check wiring against appropriate wiring diagram. Verify all terminals and connections are correct and tight. • Check module according to testing procedures information. • Clean electrode or burner cap. • Replace electrode.
No spark or only random spark at one ignitor.	Check for cracked ignitor or pinched ignitor wire Poor continuity to burner cap..... Bad ground connection or lack of continuity to ground or ignitor Cracked or broken ignitor extension lead....	<ul style="list-style-type: none"> • Replace ignitor lead or electrode. • Clean burner cap and lead. • Tighten ground connection and correct any breaks in ground path from ignitor path to unit ground path. • Replace ignitor lead.
Unit continues to spark after knob is turned to OFF position.	Shorted valve switch/harness..... Switch has slipped off the valve	<ul style="list-style-type: none"> • Replace switch/harness. If sparking is caused by excessive spillovers, customer education is advised. • Carefully reposition switch on valve and rotate from OFF to high, several times to verify switch is not broken.

Troubleshooting Procedures



WARNING

To avoid risk of electrical shock, personal injury or death; disconnect power and gas to cooktop before servicing, unless testing requires power and/or gas.

Problem	Possible Cause	Correction
No gas flows to burner.	Gas pressure too high Failed gas valve..... Loose wire connection or broken wire	<ul style="list-style-type: none"> • Check for correct gas pressure. Natural gas pressure should be 5" WCP and LP gas pressure should be 10" WCP. • Check gas valve for continuity. • Verify all connections are clean and tight, replace broken wire.
Fan motor does not operate.	No power to fan motor..... Failed fan motor or winding/frozen shaft ..	<ul style="list-style-type: none"> • Check for 120 VAC supplied at fan motor. If no voltage is present, check for broken or loose wiring between fan motor and relay board. If voltage is present at fan motor, go to the next step. • Check motor winding for continuity. Check for a frozen motor shaft. Check for broken wiring between motor and neutral terminal block.

Component Testing Procedures



WARNING

To avoid risk of electrical shock, personal injury or death; disconnect power and gas to cooktop before servicing, unless testing requires power.

Illustration	Component	Test Procedure	Results
	Burner valve, top, 360° JGD8348CDP	Verify gas is supplied. Orifice adjusted for Natural or LP. Adjust set screw for simmer control.....	To replace burner valve(s), complete assembly must be replaced (manifold and valves). 1650 BTU per hour minimum. See conversion section.
	Burner valve, left and right, 360° JGD8348CDP	Verify gas is supplied. Orifice adjusted for Natural or LP. Adjust set screw for simmer control.....	To replace burner valve(s), complete assembly must be replaced (manifold and valves). See conversion section.
	Snap switch JGD8348CDP	Test for voltage at terminals Disconnect wiring and check for continuity in LITE position.....	120 VAC Continuity in LITE position.
	Dreeds spark switch JGD8348CDP	Test for voltage at terminals Disconnect wiring and check for continuity in LITE position.....	120 VAC Continuity in LITE position.
	Burner ignition electrode JGD8348CDP	Test for resistance of spark lead ... Test ignitor to chassis.....	Continuity No continuity from ignitor to chassis.
	Sealed surface burner JGD8348CDP, JGC8430BD*, JGC8645BDS	Verify gas is supplied.....	Check for obstructions in burner ports.
	Spark module 2 + 0 JGD8348CDP	Test for voltage at terminals L and N..... Check polarity and ground.....	120 VAC See wiring diagram
	Spark module 4 + 0 JGD8348CDP	Test for voltage at terminals L and N..... Check polarity and ground.....	120 VAC See wiring diagram
	Blower motor assembly JGD8348CDP	Verify resistance between white and black wires.....	115 VAC, 60 Hz, 2.4 amps 1550 RPM, 1/10 HP, CWLE Approx. 48 Ω
	Rotary switch JGD8348CDP	Test for voltage at terminals Disconnect wiring, reference wiring diagram and check for continuity in Lo and Hi positions....	120 VAC Continuity in Lo and Hi positions.

Component Testing Procedures



WARNING

To avoid risk of electrical shock, personal injury or death; disconnect power and gas to cooktop before servicing, unless testing requires power.

Illustration	Component	Test Procedure	Results
	Venturi, front (short) JGD8348CDP	Nominal air shutter setting Tolerance.....	.375 3/8" .030 1/32"
	Venturi, rear (long) JGD8348CDP	Nominal air shutter setting Tolerance.....	.375 3/8" .030 1/32"
	Tube, front (short) JGD8348CDP	Nominal air shutter setting Tolerance.....	.250 1/4" .031 1/32" (approx.)
	Tube, rear (long) JGD8348CDP	Nominal air shutter setting Tolerance.....	.585 19/32" (approx.) .031 1/32" (approx.)
	E-burner grill assembly JGD8348CDP	Verify gas is supplied.....	Check for obstructions in burner ports.
	E-burner ignitor JGD8348CDP	Test for resistance of spark lead .. Test ignitor to chassis.....	Continuity No continuity from ignitor to chassis.
	Pressure regulator All	Verify gas pressure (W.C.P.)..... If on LP service, verify proper gas supply conversion.	5" Natural, 10" LP/propane
	270° Switch JGCP430ADP, JGCP636ADP, JGCP648ADP	Verify gas is supplied. Orifice adjusted for Natural or LP. Adjust set screw for simmer control.....	To replace burner valve(s), complete assembly must be replaced (manifold and valves). See conversion section.
	Valve switch JGCP430ADP, JGCP636ADP, JGCP648ADP	Test for voltage at terminals Disconnect wiring and check for continuity in LITE position.....	120 VAC Continuity in LITE position.
	Spark ignition electrode JGCP430ADP, JGCP636ADP, JGCP648ADP	Test for resistance of spark lead Test ignitor to chassis.....	Continuity No continuity from ignitor to chassis.
	Spark B module JGCP636ADP, JGCP648ADP	Test for voltage at terminals A and N..... Check polarity and ground.....	120 VAC See wiring diagram
	Spark module 4 + 0 JGCP430ADP	Test for voltage at terminals A and N..... Check polarity and ground.....	120 VAC See wiring diagram

Component Testing Procedures



WARNING

To avoid risk of electrical shock, personal injury or death; disconnect power and gas to cooktop before servicing, unless testing requires power.

Illustration	Component	Test Procedure	Results	
			Time On	Time Off
	Infinite switch JGCP648ADP	Remove wiring from terminals P1 and P2, connect voltmeter to P1 and P2. Measure voltages at each setting..	LO 5% MED (5-6) 50% HI 100%	95% 50% 0%
	Griddle assembly JGCP648ADP	Measure cold (room temperature) resistance between terminals	10.41 Ω to 11.51 Ω, approximately 1300 Watts	
	Surface indicator light JGCP648ADP	Measure voltage at light	120 VAC	
	Power cord 3-wire All	Verify resistance of wires to terminals	Continuity	
	Spark switch JGC8645BDS	Test for voltage at terminals Disconnect wiring and check for continuity in LITE position.....	120 VAC Continuity in LITE position.	
	Spark switch JGC8430BD*	Test for voltage at terminals Disconnect wiring and check for continuity in LITE position.....	120 VAC Continuity in LITE position.	
	270° Switch JGC8430BD*, JGC8645BDS	Verify gas is supplied. Orifice adjusted for Natural or LP. Adjust set screw for simmer control.....	To replace burner valve(s), complete assembly must be replaced (manifold and valves). See conversion section.	
	Spark ignition electrode JGC8430BD*, JGC8645BDS	Test for resistance of spark lead ... Test ignitor to chassis.....	Continuity No continuity from ignitor to chassis.	
	Surface burner	Verify gas is supplied..... Verify burner cap is positioned correctly.	Check for obstructions in burner ports.	
	Spark B module JGC8645BDS	Test for voltage at terminals A and N..... Check polarity and ground.....	120 VAC See wiring diagram	
	Spark module 4 + 0 JGC8430BD*	Test for voltage at terminals A and N..... Check polarity and ground.....	120 VAC See wiring diagram	

Disassembly Procedures



WARNING

To avoid risk of electrical shock, personal injury or death, disconnect power to cooktop before servicing, unless testing requires power.

Disassembly Procedures for Models Listed

- JGC8430BDB/W/Q/S
- JGC8645BDS

Main Top Removal

1. Shut off gas supply and disconnect electricity to unit.
2. Remove grates, caps, and knobs.

NOTE: To remove knob(s), slide a rag under the knob and pull upward.

3. Remove cooktop from installation position and place on protected surface.
4. Remove screws securing burner base to orifice holder.
5. Lift upward on burner base, disconnect ignitor wire, and remove burner base.
6. Remove main top by lifting off.

NOTE: Top is secured with double-sided tape in front.

7. Reverse procedure to reinstall.

Spark Module Removal Bottom Access

1. Gain access to the bottom of the cook top.
2. Remove screws securing spark module to access panel.
3. Remove screws securing spark module to access panel.
4. Disconnect and label wire leads from spark module.

NOTE: Mark wires for exact replacement on module.

5. Replace spark module and reverse procedure to reinstall.

Spark Module Removal

1. Remove main top, see "Main Top Removal" procedure.
2. Remove screws securing spark module cover to burner box.
3. Remove screws securing spark module to burner box.
4. Disconnect and label wire leads from spark module.

NOTE: Mark wires for exact replacement on module.

5. Replace spark module and reverse procedure to reinstall.

Surface Ignitor Removal

1. Remove screws securing burner base to orifice holder.
2. Lift upward on burner base and disconnect ignitor wire.
3. Remove screw securing ignitor to burner base.
4. Replace ignitor and reverse procedure to reinstall.

Burner Switch Removal

1. Remove main top, see "Main Top Removal" procedure.
2. Disconnect and label wire from burner switch.
3. Slide burner switch up and off burner valve stem.
4. Replace burner switch and reverse procedure to reinstall.

Manifold Pipe Removal

1. Remove main top, see "Main Top Removal" procedure.
2. Slide burner switch up and off burner valve(s).
3. Disconnect gas burner tubing from burner valve(s).
4. Remove screws securing manifold pipe to burner box bottom.
5. Disconnect gas supply line and remove regulator from manifold pipe.
6. Replace manifold pipe assembly and reverse procedure to reinstall.

Orifice Holder Removal

1. Remove main top, see "Main Top Removal" procedure.
2. Disconnect gas burner tubing from orifice holder.
3. Replace orifice holder and reverse procedure to reinstall.

Burner Tubing Removal

1. Remove main top, see "Main Top Removal" procedure.
2. Disconnect burner tubing from orifice holder and burner valve.
3. Remove burner tubing from the unit.
4. Replace burner tubing and reverse procedure to reinstall.

Disassembly Procedures



WARNING

To avoid risk of electrical shock, personal injury or death, disconnect power to cooktop before servicing, unless testing requires power.

JGC8430BD*, JGC8645BDS BODY breakdown

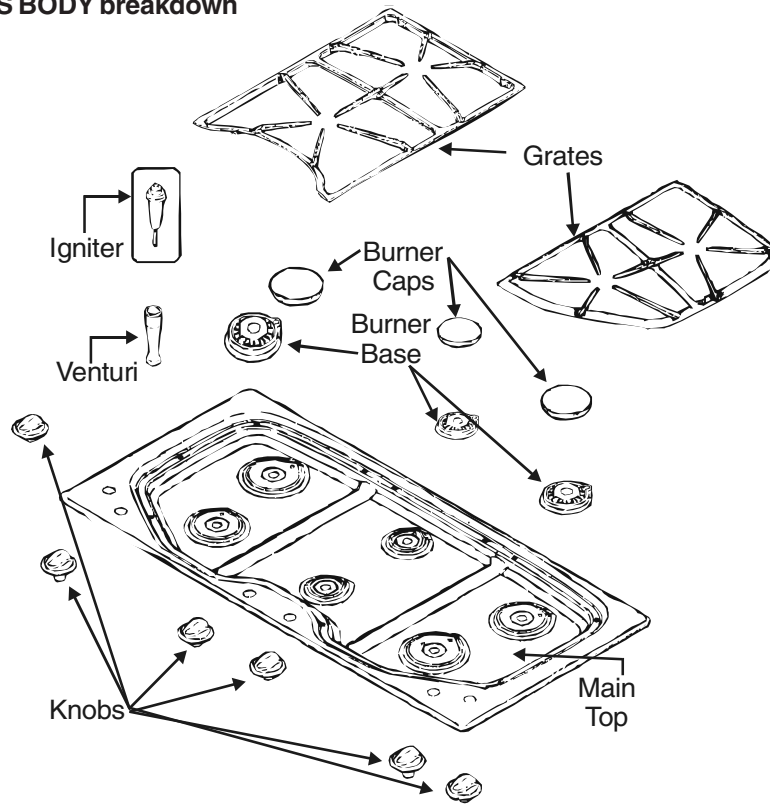

JGC8430BD*, JGC8645BDS BURNER BOX breakdown

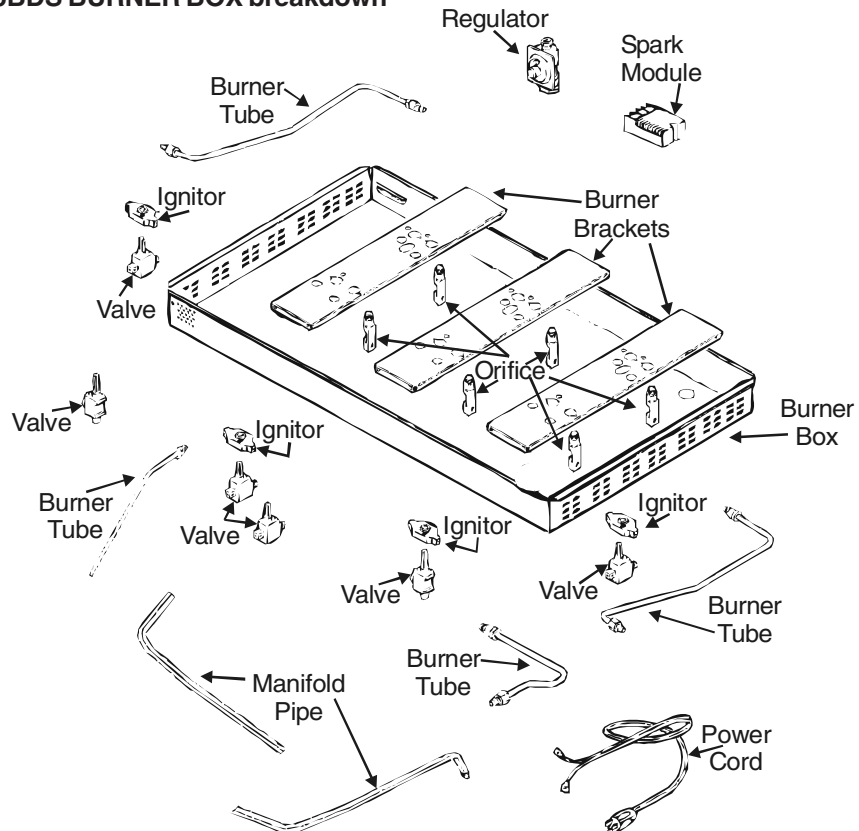

Disassembly Procedures



WARNING

To avoid risk of electrical shock, personal injury or death, disconnect power to cooktop before servicing, unless testing requires power.

Disassembly Procedures for Models Listed

- JGD8348CDP
- JGCP430ADP
- JGCP636ADP
- JGCP648ADP

Main Top Removal

1. Shut off gas supply and disconnect electricity to unit.
2. Remove grates, caps, and knobs.

NOTE: To remove knob(s), slide a rag under the knob and pull upward.

3. Remove cooktop from installation position and place on protected surface.
4. Remove screws securing burner base to orifice holder.
5. Lift upward on burner base, disconnect ignitor wire, and remove burner base, (auto re-ignition models only).
6. Remove main top by lifting off burner box.

NOTE: Top is secured with double-sided tape in front.

7. Reverse procedure to reinstall.

Spark Module Removal

1. Remove main top, see "Main Top Removal" procedure.
2. Remove spark module from bracket.
3. Disconnect and label wire leads from spark module.

NOTE: Mark wires for exact replacement on module.

4. Replace module and reverse procedure to reinstall.

Surface Ignitor Removal

1. Remove main top, see "Main Top Removal" procedure.
2. Disconnect ignitor wire from ignitor.
3. Remove screw securing ignitor to orifice holder and remove ignitor.
4. Replace ignitor and reverse procedure to reinstall.

Burner Switch Removal

1. Remove main top, see "Main Top Removal" procedure.
2. Slide burner switch up and off burner valve stem.
3. Disconnect and label wires from spark module and incoming power supply.
4. Replace burner switch and reverse procedure to reinstall.

Manifold Pipe Removal

1. Remove main top, see "Main Top Removal" procedure.
2. Disconnect gas supply line and remove regulator from manifold pipe.
3. Slide burner switch up and off burner valve(s).
4. Disconnect burner tubing from burner valve(s).
5. Remove screws securing manifold pipe to burner box bottom.
6. Replace manifold pipe assembly and reverse procedure to reinstall.

Orifice Holder Removal

1. Remove main top, see "Main Top Removal" procedure.
2. Disconnect burner tubing from orifice holder.
3. Remove screws securing orifice holder bracket to burner box.
4. Remove orifice holder bracket from burner box.
5. Remove screws securing orifice holder to orifice holder bracket.
6. Replace orifice holder and reverse procedure to reinstall.

Burner Tubing Removal

1. Remove main top, see "Main Top Removal" procedure.
2. Disconnect burner tubing from burner valve and orifice holder.
3. Replace burner tubing and reverse procedure to reinstall.

E-Burner Removal

1. Shut off gas supply and disconnect electricity to unit.
2. Remove E-Burner grate.
3. Disconnect E-Burner burner module from orifices/orifice holders.
4. Remove screws securing E-Burner module to cooktop frame.
5. Move E-Burner module by sliding toward the rear of the cooktop until the tubing clears the orifices/orifice holders.
6. Reverse procedure to install optional Two-Burner Module accessory or to reinstall E-Burner.

Disassembly Procedures



WARNING

To avoid risk of electrical shock, personal injury or death, disconnect power to cooktop before servicing, unless testing requires power.

JGD8348CDP, JGCP430ADP, JGCP636ADP, JGCP648ADP BODY breakdown

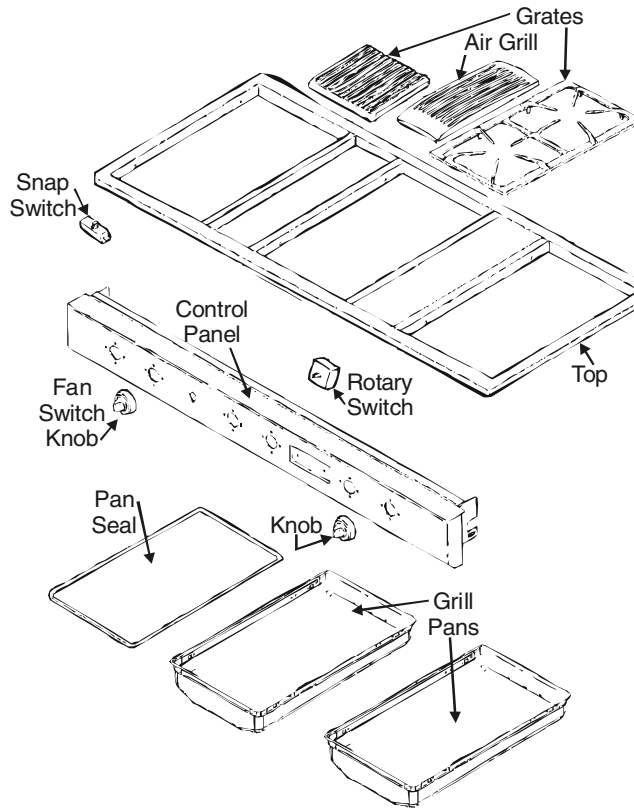

JGD8348CDP, JGCP430ADP, JGCP636ADP, JGCP648ADP BURNER BOX breakdown

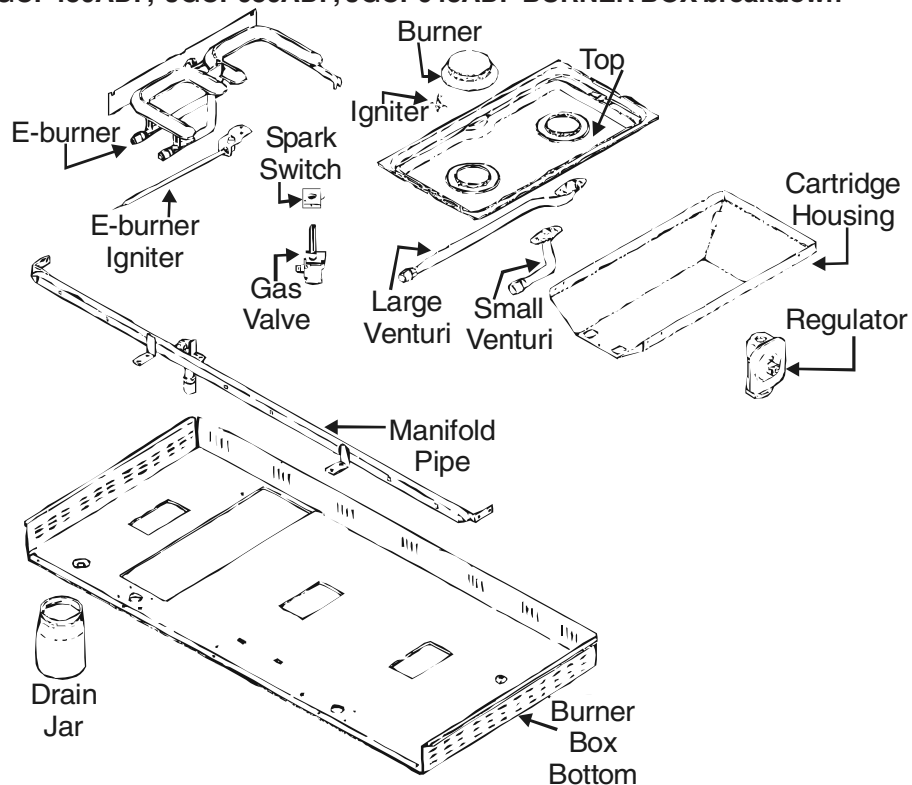

Disassembly Procedures



WARNING

To avoid risk of electrical shock, personal injury or death, disconnect power to cooktop before servicing, unless testing requires power.

Grease Filter Removal

The grease filter rests against the vent opening and plenum ventilation chamber.

1. Remove air grill.
2. Remove grease filter by grasping the "D" ring (located along the top edge of the filter) and pulling slightly outward and upward until the filter clears the air chamber.
3. Reverse procedure to replace grease filter.

Blower Removal

1. Shut off gas supply and disconnect electricity to unit.
2. Gain access to blower motor assembly, located under the cooktop surface.
3. Remove screws securing blower motor assembly to cooktop frame or other cabinet surface.
4. Remove screws securing blower motor assembly to ductwork.
5. Disassemble blower motor assembly to replace appropriate part.
6. Reverse procedures to reassembly/reinstall blower motor assembly.

JGD8348CDP BLOWER MOTOR ASSEMBLY breakdown

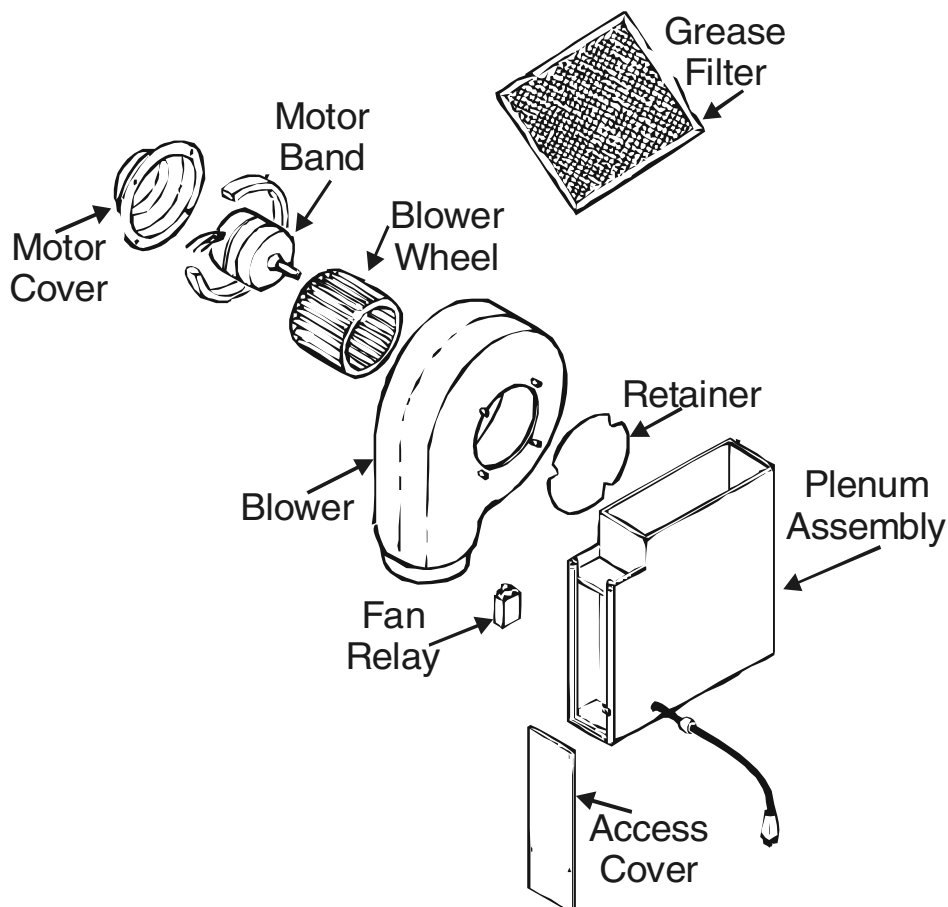

Appendix A

Installation Instructions JGCP430ADP, JGCP636ADP, JGCP648ADP

This is the first page of the Installation Instructions. See part number listed in the bottom right corner for complete set of instructions.

INSTALLATION INSTRUCTIONS

Prostyle Cooktops
JGCP430ADP, JGCP636ADP,
and JGCP648ADP

JENN-AIR

403 WEST FOURTH STREET, NORTH • NEWTON, IA 50208



SPECIAL WARNING

Improper installation, adjustment, alteration, service, maintenance or use of appliance can result in serious injury or property damage.

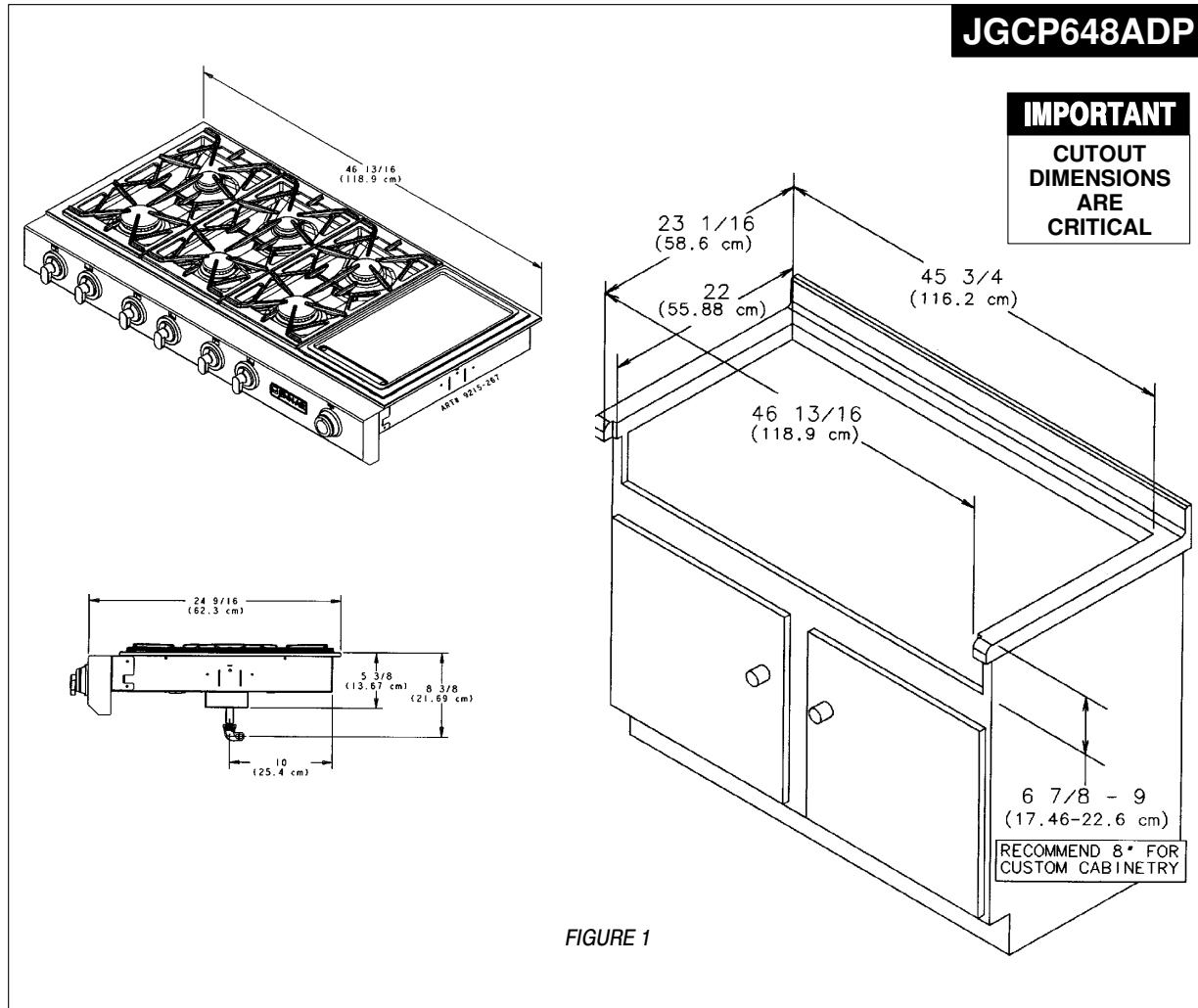

- **ACCESS MUST BE PROVIDED TO REMOVE AN EMPTY GREASE CONTAINER.**
- **NOTICE TO INSTALLER:** Leave these instructions with the appliance.
- **NOTICE TO CONSUMER:** Retain these instructions for future reference.

8101P546-60
(12-03-01)

Installation Instructions JGCP430ADP, JGCP636ADP, JGCP648ADP

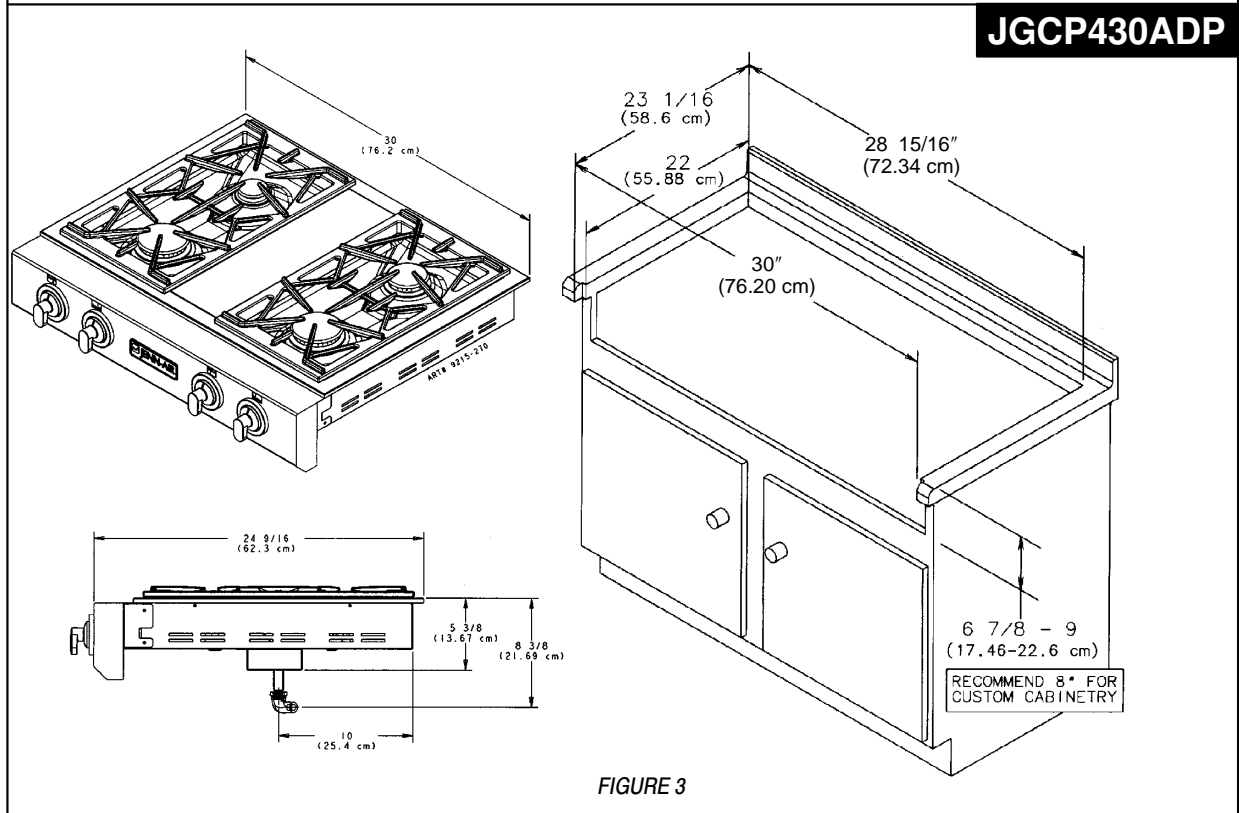
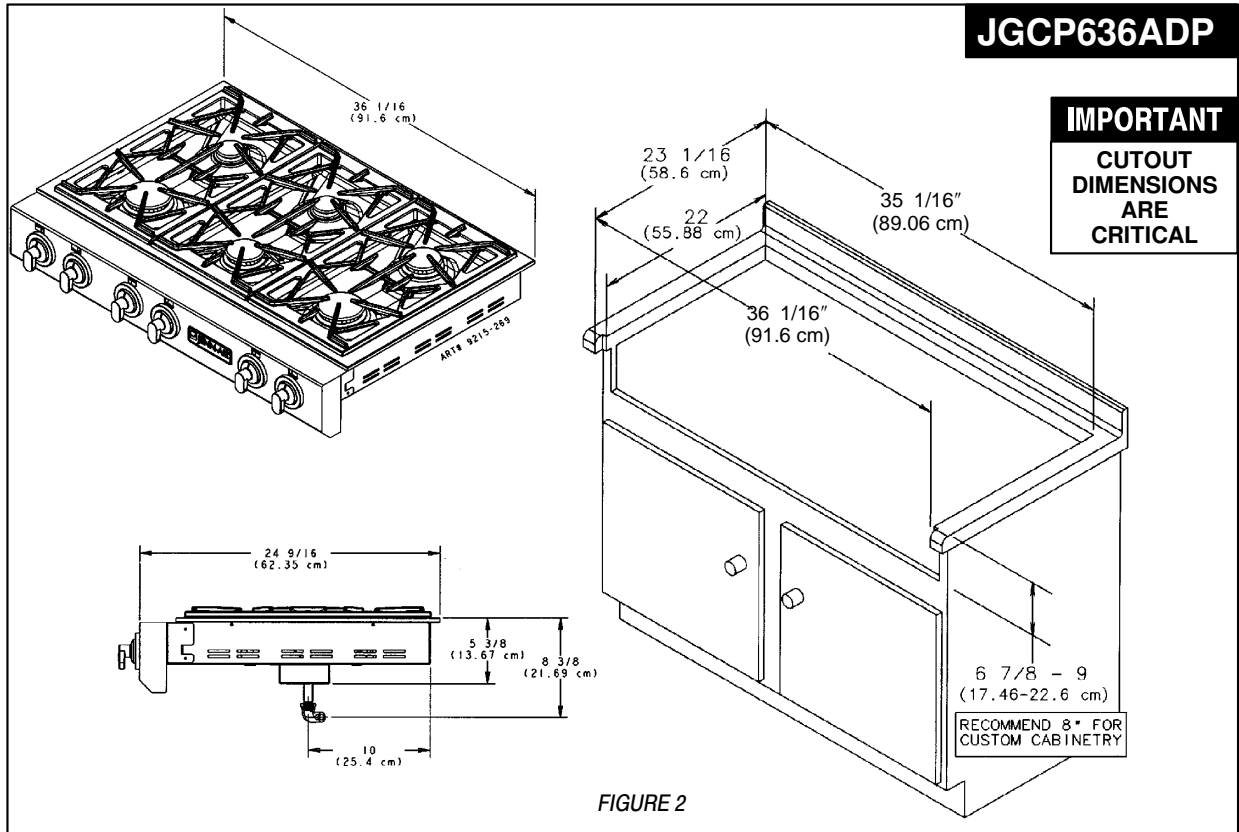

Installation Instructions JGD8348CDP

This is the first page of the Installation Instructions. See part number listed in the bottom right corner for complete set of instructions.

INSTALLATION INSTRUCTIONS	Triple Bay Conventional Gas Prostyle™ Grill Cooktop Model JGD8348CDP	 403 WEST FOURTH STREET, NORTH • NEWTON, IA 50208
----------------------------------	---	---

Dimensions shown in both inches and centimeters

NOTICE TO INSTALLER: Leave these instructions with the appliance.

NOTICE TO CONSUMER: Retain these instructions for future reference.

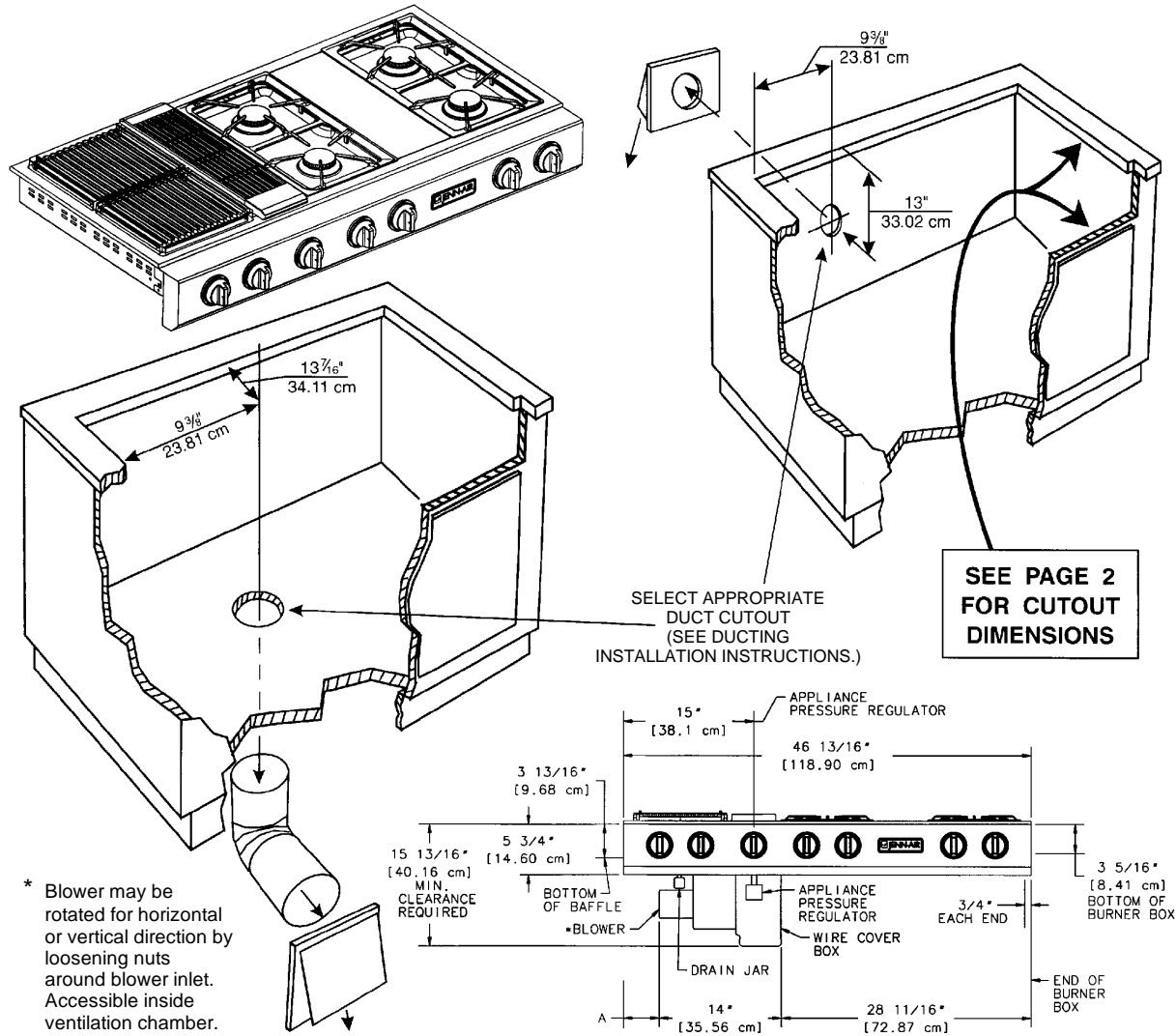

INSTRUCTIONS TO INSTALLER:

- Dimension "A" - provide 2" min. (5.08 cm) cabinet clearance to motor for cooling purpose.
- **NOTE:** Where possible, 6" (15.54 cm) is recommended for motor/blower service.
- Side Clearance: Grills installed near a side wall must allow a minimum clearance of 8" (20.32 cm).
- Access must be provided to remove and empty grease container.

8101P620-60
(11-03-00)

**DUCTING
INSTRUCTIONS
PART No. 205933**

**GRILL-RANGE
COOKTOP MODELS CONVERTIBLE
NON-CONVERTIBLE**

JENN-AIR
403 WEST FOURTH STREET, NORTH • NEWTON, IA 50208

**DUCTING MUST CONFORM TO LOCAL CODE MATERIALS AND
"MAKE-UP" REQUIREMENTS - 300 CFM MINIMUM**

IMPORTANT: Save for local Electrical Inspector's use.



- Ducting a Jenn-Air Cooktop is easy but critical for proper performance.
- After reading these instructions, plan the duct run.
- Use the 'Duct Length Chart' to find the equivalent length of the run.
- Shift the blower to 'High Range' if indicated (Done by snapping the 'restrictor ring' out of the blower inlet). Be sure blower is not running.
- Install the duct hardware.
- Enjoy grilling and cooking at its finest!

**IMPORTANT
THIS UNIT IS RATED AT 60 FEET OF STRAIGHT DUCT
LOW RANGE IS UP TO 30 FEET - HIGH RANGE IS 31 TO 60 FEET**

GENERAL CONSIDERATIONS:

1. Use 6" diameter round or 3¼" x 10" rectangular only, except as follows: **For Electric Models**, 5" diameter round may be used for venting straight out the back of the cooktop and directly through the wall for 10 feet or less. **For Gas Models**, 5" diameter round **Must** be used if the duct length is 10 feet or less.
2. Do not use 5" elbows except in a 5" system. Instead, use a 5" to 6" transition followed by a 6" elbow, or a 5" to 3¼" x 10" elbow transition.
3. Use quality metal duct of at least 26 gauge galvanized or 24 gauge aluminum. Inferior quality pipe and fittings can cause up to twice the restriction shown and is a poor value. See box on page 4 for optional under-slab ducting. Local codes may require a heavier gauge material or restrict PVC.
4. Distance between adjacent fittings (elbows, transitions, etc.) should be at least 18". The farther the better. Closer distance promotes turbulence which reduces airflow.
5. The number of downstream elbows or transitions should be limited to three. The initial 5" to 6" straight transition, if used, need not be counted in this number.
6. Handmade crimps are likely to cause restrictions.
7. If an alternate wall or roof cap is used, be certain duct size is not reduced, and that there is a backdraft damper. It is best to use listed caps to be certain of proper performance.
8. Thermal breaks: In areas of extreme cold weather, it may be necessary to provide a short length of nonmetallic duct as close to the wall as possible, to prevent conduction along the metal duct.
9. High altitude installations: It is advisable to reduce allowable duct run by 20%.
10. Follow the duct calculation on page 2 carefully for best performance and satisfaction.
11. In Canada, the installation of this appliance must conform with local codes or, in the absence of local codes with the current CAN/CGA-B149 Installation Code and current CSA Standard C22.1 Canadian Electrical Code Part. 1.

Installation Instructions Ducting Instructions JGD8348CDP

PLAN THE DUCT RUN

1. Make a sketch of the total system. Identify the type of each fitting and the length of straight pipe.
2. Enter your run into the 'Duct Length Chart' in the next section.

Example 1

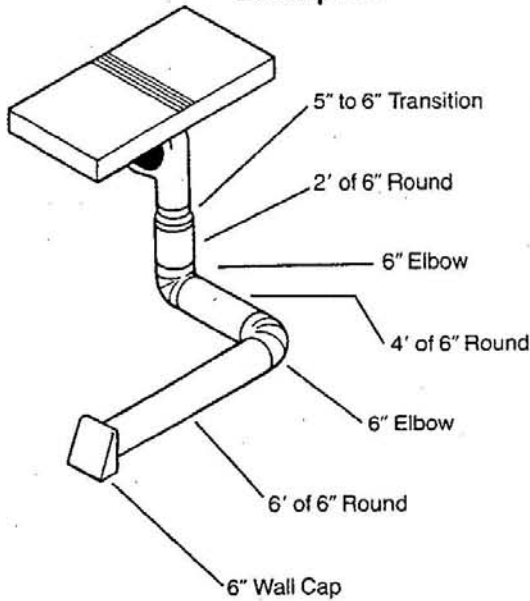

Example 2

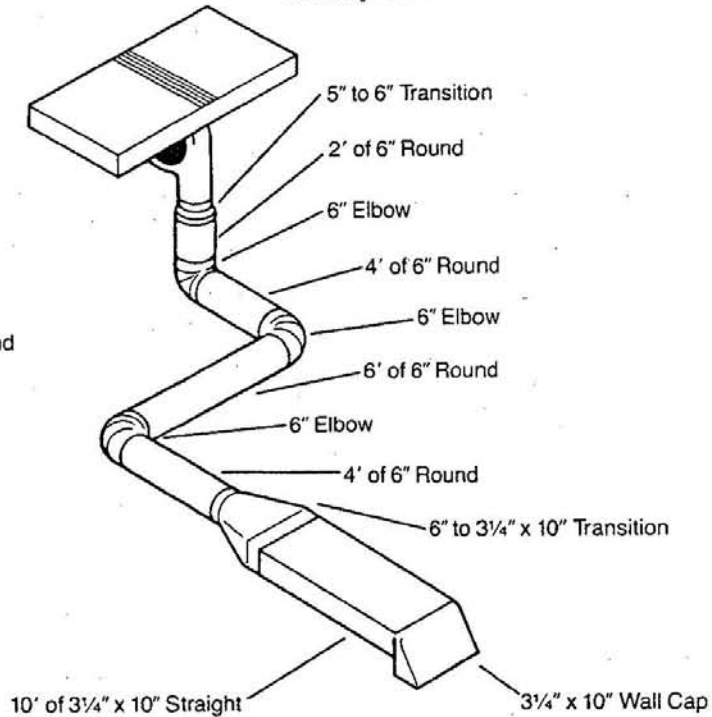

DUCT LENGTH CHART

1. Elbows, wall caps and other fittings are shown in the table on page 3 with their equivalent straight duct length. Each fitting value must be added to the amount of straight duct length used, to determine the overall straight duct equivalent length.
2. Using the examples above:

Example 1

	Duct Fitting Equivalent Length	Number of Fittings	Total Equivalent Length-Fittings
5" to 6" Transition	1	1	1
6" Straight	1	2+4+6 = 12	12
6" Elbow	5	2	10
6" Wall Cap	0	1	0
Total			23

Example 2

	Duct Fitting Equivalent Length	Number of Fittings	Total Equivalent Length-Fittings
5" to 6" Transition	1	1	1
6" Straight	1	2+4+6+4=16	16
6" Elbow	5	3	15
6" to 3 1/4"x10" Transition	1	1	1
3 1/4"x10" Straight	1	10	10
3 1/4" x 10" Wall Cap	0	1	0
Total			43

INSTALL THE DUCT HARDWARE

1. Using good quality ducting material, install per these instructions. Follow the General Considerations on page 1, Do's and Don't's box on page 4, and Cooktop Installation Instructions. A few minutes and pennies spent now will pay long term dividends for the life of the range.

Installation Instructions Ducting Instructions JGD8348CDP

USE TABLE BELOW TO CALCULATE TOTAL SYSTEM

Duct Fitting	Duct Fitting Equivalent Length	Number of Fittings	Total Equivalent Length-Fittings
6" Dia. 90° Elbow	5 ft. (1.52 m)		
6" Dia. 45° Elbow	2.5 ft. (.76 m)		
5" to 6" Transition (12.7 cm to 15.24 cm) P/N A456	1.0 ft. (.30 m)		
6" to 3 1/4" x 10" 90° Elbow (15.24 cm to 8.26 x 25.4 cm) P/N A496	5 ft. (1.52 m)		
3 1/4" x 10" to 6" 90° Elbow (8.26 cm x 25.4 cm to 15.24 cm) P/N A496	9 ft. (2.75 m)		
6" to 3 1/4" x 10" Transition (15.24 cm to 8.26 cm x 25.4 cm) P/N A463 (Also P/N A453 in Side Duct)	1 ft. (.30 m)		
3 1/4" x 10" to 6" Transition (8.26 cm x 25.4 cm to 15.24 cm) P/N A463	4.5 ft. (1.37 m)		
5" to 3 1/4" x 10" 90° Elbow (12.7 cm to 8.26 cm x 25.4 cm) P/N A495	6 ft. (1.83 m)		
3 1/4" x 10" 90° Elbow (8.26 cm x 25.4 cm)	5 ft. (1.52 m)		
3 1/4" x 10" Flat Elbow (8.26cm x 25.4 cm)	12 ft. (3.66 m)		
6" Wall Cap (15.24 cm) P/N A406	0 ft. (0 m)		
5" Wall Cap (12.7 cm) P/N A405 (Short Run)	0 ft. (0 m)		
3 1/4" x 10" Wall Cap (8.26 cm x 25.4 cm) P/N A403	0 ft. (0 m)		
10" x 10" Roof Jack (25.4 cm x 25.4 cm) Use Leigh Products P/N 5950 (Also available as Jenn-Air P/N 701943)	0 ft. (0 m)		
Thermal Break 5" P/N 708786 6" P/N 715557	2 ft. (.61 m)		
6" Diameter (for flex duct, multiply by 2) Straight Duct - Feet	1 ft. (.30 m)		
3 1/4" x 10" Straight Duct - Feet	1 ft. (.30 m)		
SYSTEM TOTAL			

SHIFTING THE BLOWER FROM 'LOW RANGE' TO 'HIGH RANGE'

1. This cooktop is equipped with a dual range blower. It is shipped from the factory in **LOW RANGE** for most installations. **If the Equivalent Duct Length exceeds 30 feet, it must be shifted to HIGH RANGE. Do not shift to high range for shorter lengths. This will cause excessive noise, conditioned air loss and affect the flame pattern on gas units.**

In the examples on the preceding page, the blower in example #1 should be installed as received from the factory. The blower in example #2 should be shifted to High Range.

2. To shift to **HIGH RANGE**, be sure blower is stopped and pop the spring loaded 'RESTRICTER RING' out of the blower inlet. See illustration at right.

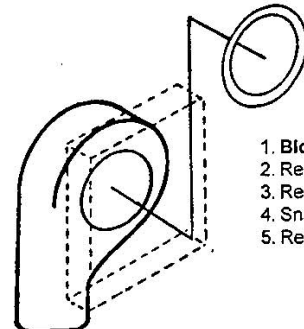

1. Blower Off
2. Remove air grill
3. Remove filter
4. Snap out restricter ring
5. Replace grill & Filter

Installation Instructions Ducting Instructions JGD8348CDP

TYPICAL DUCT ARRANGEMENTS COUNTER TOP SERIES

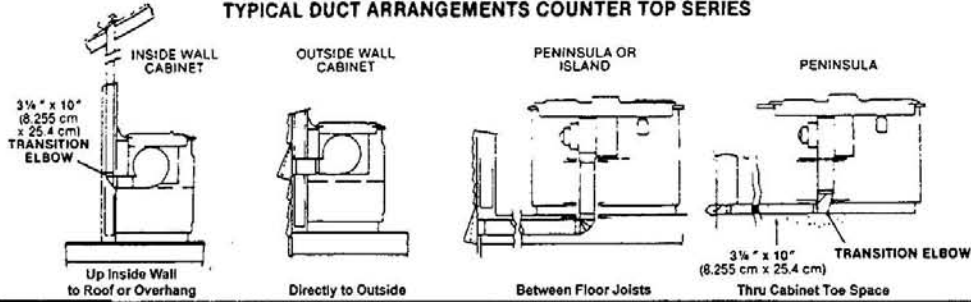

OPTIONAL DUCT ARRANGEMENT UNDER CONCRETE SLAB

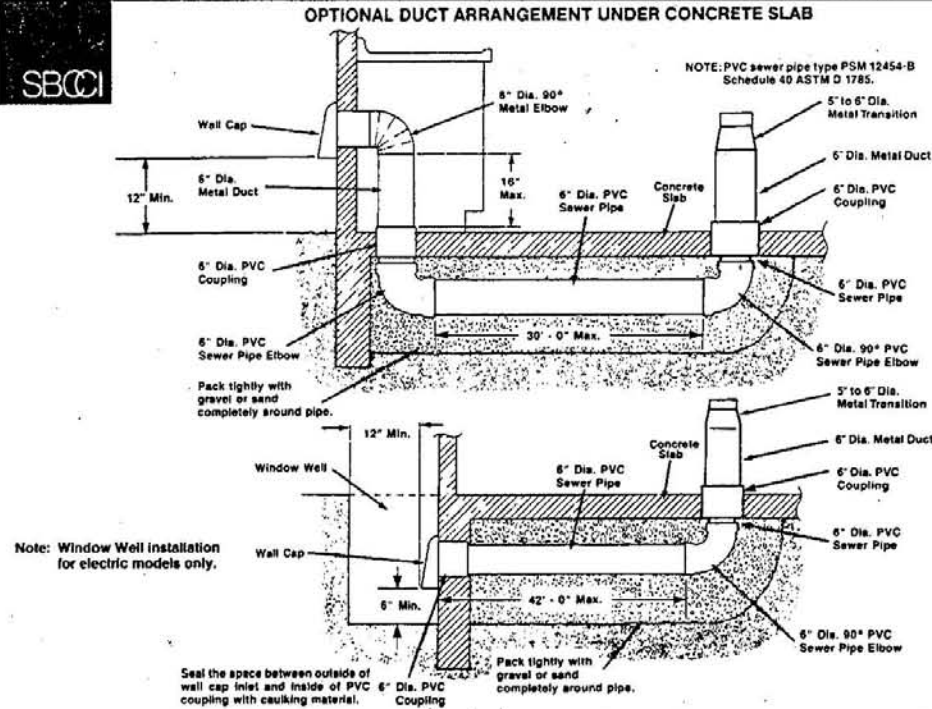

Note: Window Well installation for electric models only.

Do	Don't
Use 5" (12.7 cm), 6" (15.24 cm), or 3 1/4" x 10" (8.255 cm x 25.4 cm) pipe as recommended for your model.	Use 4" (10.6 cm) dryer vent pipe or flex duct*
Use recommended wall caps.	Use laundry type wall cap.
Use no more than one 90° elbow with five inch (12.7 cm) duct or three 90° elbows with six inch (15.2 cm) or 3" x 10" (8.255 cm x 25.4 cm) duct.	Over run your system with too many bends and turns.
Duct system to the outside.	Vent into an attic or crawl space, walls and concealed space of a building.
Mix 6" (15.24 cm) duct and 3 1/4" x 10" duct (8.255 cm x 25.4 cm) within the same system if necessary.	Reduce back to 5" (12.7 cm) system after using 6" (15.24 cm) or 3 1/4" x 10" (8.255 cm x 25.4 cm).
Tape all joints securely with several wraps of tape.	Butt joints, always use male-female connections in direction of flow.
Use one unit per duct system.	Exhaust more than one unit into a single system.

*Although not recommended, 5" or 6" metal flex duct may be used. Due to the irregular surface of flexible ducting, each foot of flex duct counts as two (2) feet of regular metal duct. Also, each elbow made in flex duct would count twice as much as standard metal elbow. The best idea with flexible ducting is to keep it as short and as straight as possible.

Wall Caps/Thermal Breaks

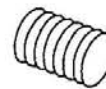

P/N 708786

Fits 5" (12.7 cm) Round Duct. Adds 2 ft. to duct length calculation.

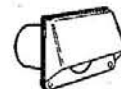

Model A405

Fits 5" (12.7 cm) Round Duct. Requires 5 1/4" (13.34 cm) Dia opening.

P/N 715557

Fits 6" (15.25 cm) Round Duct. Adds 2 ft. to duct length calculation.

Model A406

Fits 6" (15.24 cm) Round Duct. Requires 6 1/4" (15.875 cm) Dia opening.

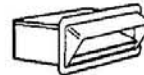

Model A403

Single-damper, down discharge to fit 3 1/4" x 10" (8.255 cm x 25.4 cm) duct.



Leigh Products

P/N 5950
Roof Jack 10" x 10" (25.4 cm x 25.4 cm)

Part No. 205933B
8101P183-60

Installation Instructions JGC8430BD*

This is the first page of the Installation Instructions. See part number listed in the bottom right corner for complete set of instructions.

INSTALLATION MANUAL

SEALED GAS COOKTOP JGC8430 & JGC8536

JENN-AIR

403 WEST FOURTH STREET, NORTH • NEWTON, IA 50208

IMPORTANT: Dimensions Shown in Both Inches and Centimeters.

IMPORTANT: Be sure the appliance being installed is equipped for the gas to be supplied. Refer to serial plate on underside of burner box for this information. Do not attempt to convert this appliance for use with a gas other than the type specified.



30" MODEL

JGC8430		
	Inches	cm
A	28 3/4 ± 1/16	73.03 ± .2
B	20 5/8 ± 1/16	52.39 ± .2
C	2 MIN	5.08 MIN
D	5 1/16	12.9
E	30	76.2
F	21 3/4	55.2
G	3 11/16	9.4
H	12 7/16	31.6
I	1 3/4	4.4
J	1 3/4	4.4

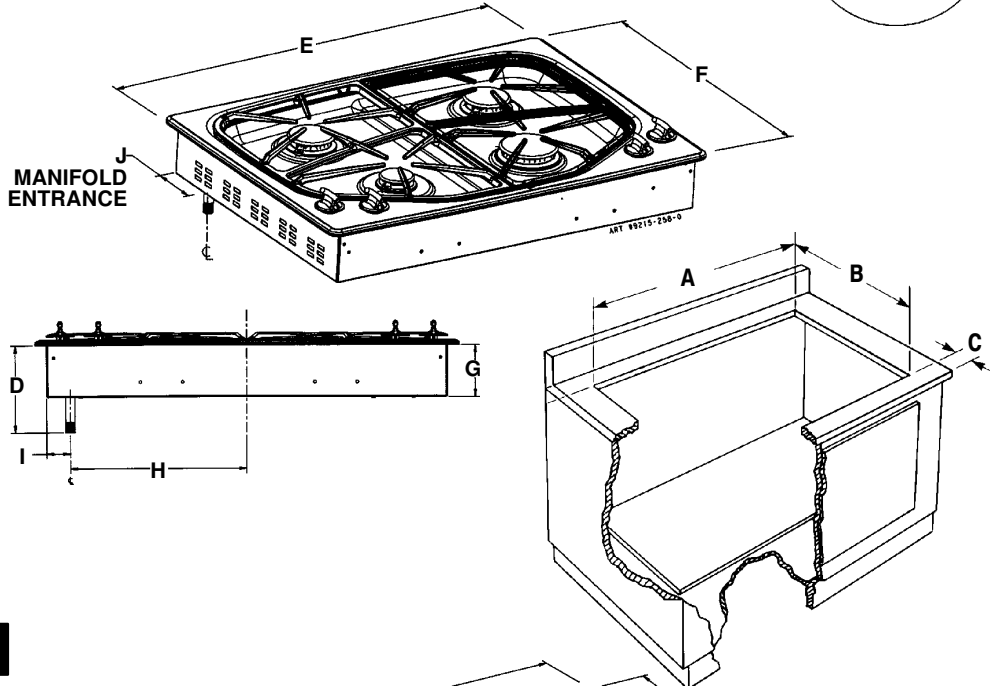

36" MODEL

JGC8536		
	Inches	cm
A	34 7/8 ± 1/16	88.58 ± 1/16
B	20 13/16 ± 1/16	52.86 ± 1/16
C	2 MIN	5.08 MIN
D	4 9/16	11.6
E	36	91.4
F	21 9/16	54.8
G	3 13/16	9.6
H	15 1/2	39.4
I	1 3/4	4.4
J	1 3/4	4.4

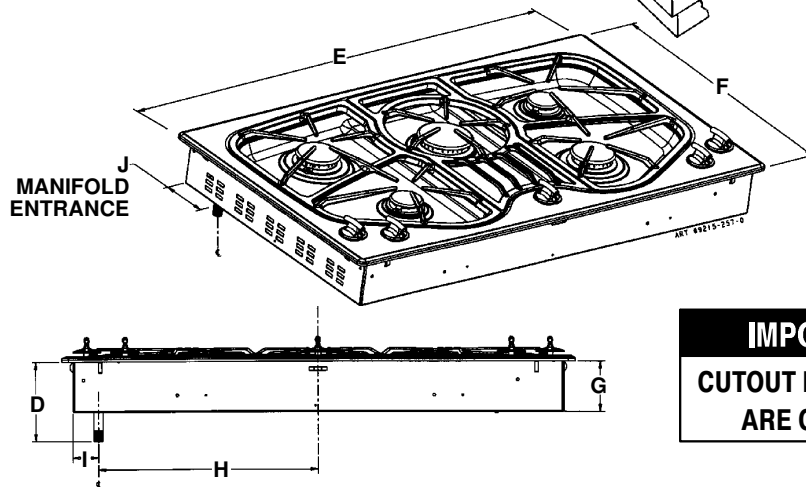

IMPORTANT
CUTOUT DIMENSIONS
ARE CRITICAL

SPECIAL WARNING

IMPROPER INSTALLATION, ADJUSTMENT, ALTERATION, SERVICE, MAINTENANCE OR USE OF RANGE CAN RESULT IN SERIOUS INJURY OR PROPERTY DAMAGE.

NOTICE TO INSTALLER: LEAVE THESE INSTRUCTIONS WITH THE APPLIANCE.

NOTICE TO CONSUMER: RETAIN THESE INSTRUCTIONS FOR FUTURE REFERENCE.

8101P643-60
(05-04-00)

Installation Instructions JGC8645BDS

This is the first page of the Installation Instructions. See part number listed in the bottom right corner for complete set of instructions.

INSTALLATION MANUAL

SEALED GAS COOKTOPS JGC8645



403 WEST FOURTH STREET, NORTH • NEWTON, IA 50208

IMPORTANT: Dimensions Shown in Both Inches and Centimeters.

IMPORTANT: Be sure the appliance being installed is equipped for the gas to be supplied. Refer to serial plate on underside of burner box for this information. Do not attempt to convert this appliance for use with a gas other than the type specified.



45" MODEL

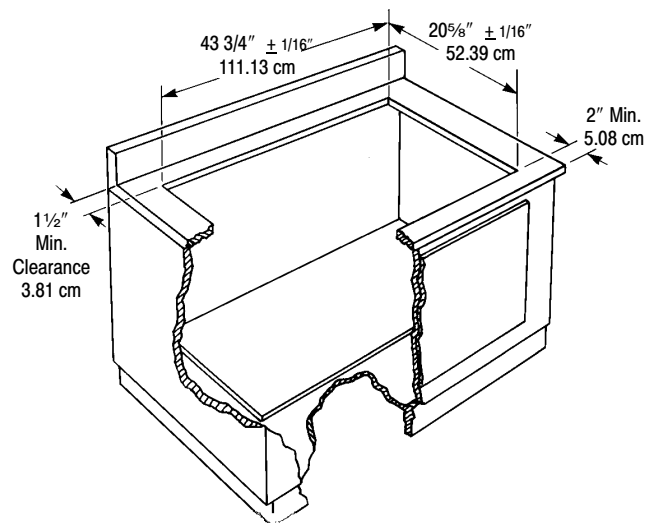
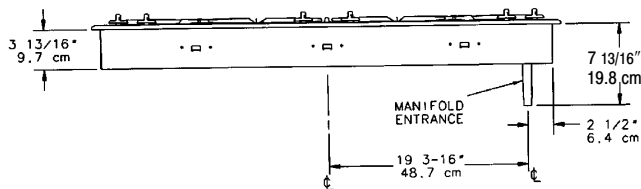
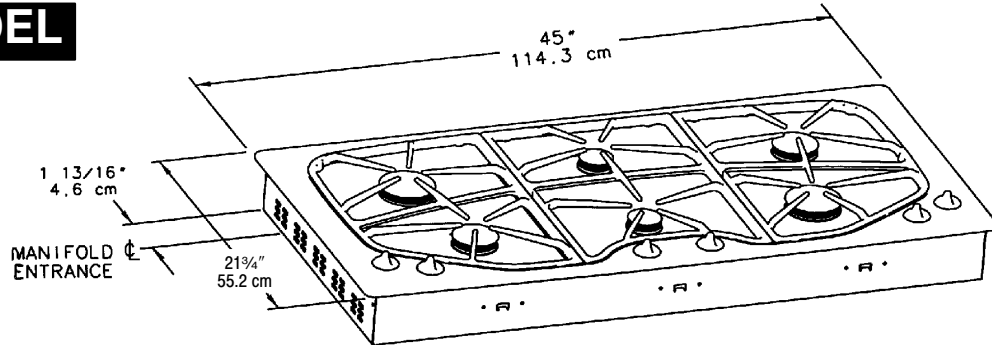

IMPORTANT
CUTOUT DIMENSIONS
ARE CRITICAL

SPECIAL WARNING

IMPROPER INSTALLATION, ADJUSTMENT, ALTERATION, SERVICE, MAINTENANCE OR USE OF APPLIANCE CAN RESULT IN SERIOUS INJURY OR PROPERTY DAMAGE.

NOTICE TO INSTALLER: LEAVE THESE INSTRUCTIONS WITH THE APPLIANCE.

NOTICE TO CONSUMER: RETAIN THESE INSTRUCTIONS FOR FUTURE REFERENCE.

8101P644-60
(05-04-00)

Appendix B

USING YOUR COOKTOP

Surface Controls

CAUTION

- If flame should go out during a cooking operation, turn the burner off. If a strong gas odor is detected, open a window and wait five minutes before relighting the burner.
- Be sure all surface controls are set to the **OFF** position prior to supplying gas to the cooktop.
- **NEVER** touch cooktop until it has cooled. Expect some parts of the cooktop, especially around the burners, to become warm or hot during cooking. Use potholders to protect hands.

Surface Control Knobs

Use to turn on the surface burners. An infinite choice of heat settings is available from **LOW** to **HIGH**.

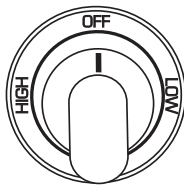

Setting the Controls

Your cooktop has sealed gas burners with automatic re-ignition. If the burner flame should go out, the system will automatically spark to re-ignite the burner.

1. Place a pan on the burner grate. (To preserve the grate finish, do not operate the burners without a pan on the grate to absorb the heat from the burner flame.)
2. Push in knob and turn immediately counterclockwise to the desired setting.
 - A clicking (spark) sound will be heard and the burner will light. (All ignitors will spark when any surface burner knob is turned on. However, only the selected burner will light.)

Pilotless Ignition

Pilotless ignition eliminates the need for a constant standing pilot light. Each surface burner has a spark ignitor. Use care when cleaning around the surface burner.

If the surface burner does not light, check if ignitor is broken, soiled or wet.

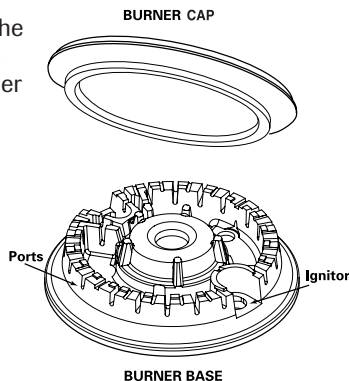

Operating During a Power Failure

1. Hold a lighted match to the desired surface burner head.
2. Push in and turn the control knob slowly to the desired setting.

CAUTION

- When lighting the surface burners, be sure all of the controls are in the **OFF** position. Strike the match first and hold it in position before turning the knob.
- **Do not** leave the cooktop unattended when cooking during a power failure. The automatic re-ignition feature will not operate during a power failure.

Suggested Heat Settings

The size and type of cookware will affect the heat setting. For information on cookware and other factors affecting heat settings, refer to "Cooking Made Simple" booklet.

SETTINGS	USES
<p>HIGH</p>	<p>Use HIGH to bring liquid to a boil, or reach pressure in a pressure cooker. Always reduce setting to a lower heat when liquids begin to boil or foods begin to cook.</p> <p>An intermediate flame size is used to continue cooking. Food will not cook any faster when a higher flame setting is used than needed to maintain a gentle boil. Water boils at the same temperature whether boiling gently or vigorously.</p>
<p>LOW</p>	<p>Use LOW to simmer foods, keep foods warm and melt chocolate or butter.</p> <p>Some cooking may take place on the LOW setting if the pan is covered. It is possible to reduce the heat by rotating the knob toward OFF. Be sure flame is stable.</p>

USING YOUR COOKTOP

Cooktop at a Glance

MODEL JGCP648ADP

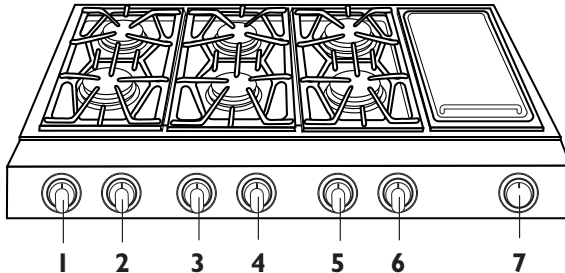

1. Left rear burner (5,000 BTUs on HIGH, 600 BTUs on LOW). This burner is designed for cooking delicate items.
2. Left front burner (17,000 BTUs). This burner may be used to quickly bring water to a boil for large quantity cooking.
3. Center rear burner (5,000 BTUs on HIGH, 600 BTUs on LOW). This burner is designed for cooking delicate items.
4. Center front burner (9,200 BTUs).
5. Right rear burner (9,200 BTUs).
6. Right front burner (17,000 BTUs). This burner may be used to quickly bring water to a boil for large quantity cooking.
7. Electric griddle (1,300 Watts.)

MODEL JGCP636ADP

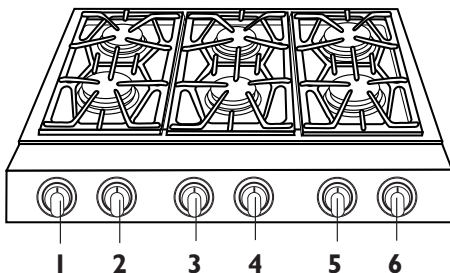

1. Left rear burner (5,000 BTUs on HIGH, 600 BTUs on LOW). This burner is designed for cooking delicate items.
2. Left front burner (17,000 BTUs). This burner may be used to quickly bring water to a boil for large quantity cooking.
3. Center rear burner (5,000 BTUs on HIGH, 600 BTUs on LOW). This burner is designed for cooking delicate items.
4. Center front burner (9,200 BTUs).
5. Right rear burner (9,200 BTUs).
6. Right front burner (17,000 BTUs). This burner may be used to quickly bring water to a boil for large quantity cooking.

MODEL JGCP430ADP

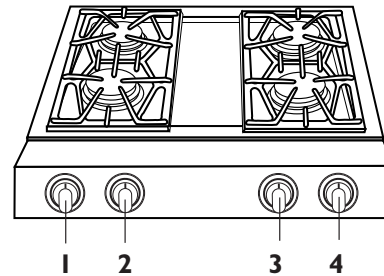

1. Left rear burner (5,000 BTUs on HIGH, 600 BTUs on LOW). This burner is designed for cooking delicate items.
2. Left front burner (17,000 BTUs). This burner may be used to quickly bring water to a boil for large quantity cooking.
3. Right rear burner (9,200 BTUs).
4. Right front burner (17,000 BTUs). This burner may be used to quickly bring water to a boil for large quantity cooking.

Sealed Burners

The sealed burners are secured to the cooktop and are not designed to be removed. Since the burners are sealed into the cooktop, boilovers or spills will not seep underneath the cooktop.

However, the burners should be cleaned after each use. The head portion of the burner is easily removed for cleaning. (See page 7 for cleaning directions.)

Burner caps must be correctly placed on the burner base for proper operation of the burner.

High Performance Burners*

There are two high speed burners on your cooktop, located in the left and right front positions. These burners offer higher speed cooking that can be used to quickly bring water to a boil and for large-quantity cooking.

Simmer Burners*

These burners are located in the left and center rear (select models) or the left rear position. The simmer burner offers a lower BTU flame for delicate sauces or melting chocolate.

* BTU ratings will vary when using LP gas.

BTU Ratings for LP Gas

17,000 BTUs natural gas = 15,000 BTUs LP gas

9,200 BTUs natural gas = 9,100 BTUs LP gas

5,000 BTUs natural gas = 4,000 BTUs LP gas

USING YOUR COOKTOP

SURFACE CONTROLS

CAUTIONS:

- If flame should go out during a cooking operation, turn the burner off. If a strong gas odor is detected, open a window and wait five minutes before relighting the burner.
- Be sure all surface controls are set to the OFF position prior to supplying gas to the cooktop.
- **NEVER** touch cooktop until it has cooled. Expect some parts of the cooktop, especially around the burners, to become warm or hot during cooking. Use potholders to protect hands.

or notch may be felt. The knobs can be set on or between any of the settings.

Graphics next to the knob identify which burner the knob controls. For example, the graphic at right shows the right front burner location.



SETTING THE CONTROLS

1. Place a pan on the burner grate. (To preserve the grate finish, do not operate the burners without a pan on the grate to absorb the heat from the burner flame.)
2. Push in knob and turn immediately counterclockwise to the **Lite** setting until burner ignites.
 - A clicking (spark) sound will be heard and the burner will light. All ignitors will spark when any surface burner knob is turned to the **Lite** position.

3. After ignition, turn knob clockwise to desired setting.
 - The ignitor will continue to spark until the knob is turned past the **Lite** position.

OPERATING DURING A POWER FAILURE

1. Hold a lighted match to the desired surface burner head.
2. Push in and turn the control knob slowly to **Lite**.
3. Adjust the flame to the desired level.

CAUTION:

- When lighting the surface burners, be sure all of the controls are in the OFF position. Strike the match first and hold it in position before turning the knob to **Lite**.

PILOTLESS IGNITION

Pilotless ignition eliminates the need for a constant standing pilot light. Each surface burner has a spark ignitor. When cleaning around the surface burner use care. If cleaning cloth should catch the ignitor, it could damage it preventing ignition.

If the surface burner does not light, check if ignitor is broken, soiled or wet. If clogged, clean the small port beneath the ignitor using straight pin.

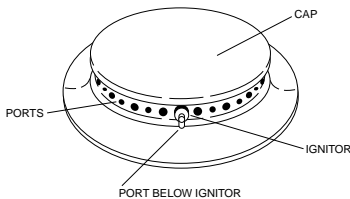

SUGGESTED HEAT SETTINGS

The size and type of cookware will affect the heat setting. For information on cookware and other factors affecting heat settings, refer to “Cooking Made Simple” booklet.

Settings	Uses
<p>Hi</p>	<p>Use Hi to bring liquid to a boil, or reach pressure in a pressure cooker. Always reduce setting to a lower heat when liquids begin to boil or foods begin to cook.</p>
<p>Lo</p>	<p>An intermediate flame size is used to continue cooking. Food will not cook any faster when a higher flame setting is used than needed to maintain a gentle boil. Water boils at the same temperature whether boiling gently or vigorously.</p> <p>Use Lo to simmer foods, keep foods warm and melt chocolate or butter.</p> <p>Some cooking may take place on the Lo setting if the pan is covered. It is possible to reduce the heat by rotating the knob toward OFF. Be sure flame is stable.</p>

SURFACE CONTROL KNOBS

Use to turn on the surface burners. An infinite choice of heat settings is available from **Lo** to **Hi**. At the **Hi** setting a detent

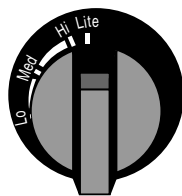

USING YOUR COOKTOP, CONT.

CONTROL LOCATIONS

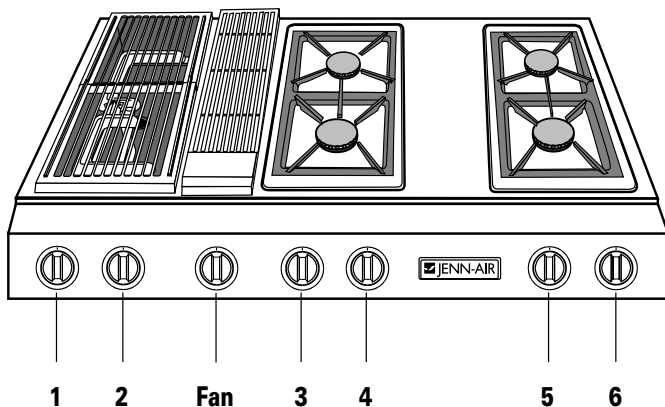

1. Left rear surface burner or grill.
2. Left front surface burner or grill.
3. Center rear surface burner.
4. Center front surface burner.
5. Right rear surface burner.
6. Right front surface burner.

NOTE: When using a JGA8100 surface burner assembly with control locations #1 and #2, the control knob may be turned to a position lower than the **Lo** setting. (The **Lo** setting is set for the grill burner.)

NOTES:

- A properly adjusted burner with clean ports will light within a few seconds. If using natural gas, the flame will be blue with a deeper blue inner cone.
If the burner flame is yellow or is noisy, the air/gas mixture may be incorrect. Contact a service technician to adjust. (Adjustments are not covered by the warranty.)
With LP gas, some yellow tips on the flames are acceptable. This is normal and adjustment is not necessary.
- With some types of gas, you may hear a “popping” sound when the surface burner is turned off. This is a normal operating sound of the burner.
- If the control knob is turned very quickly from **hi** to **lo**, the flame may go out, particularly if the burner is cold. If this occurs, turn the knob to the **OFF** position, wait several seconds and relight the burner.
- Leave a minimum of 1 1/2" between side of pan and surrounding surfaces such as countertop, back splashes or side walls, to allow heat to escape and avoid possible damage to these areas.
- To improve cooking efficiency and to prevent possible damage to the cooktop or pan, the flame must be adjusted so it does not extend beyond the edge of the pan.

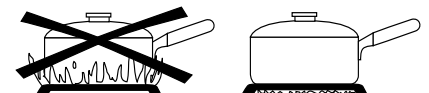

COOKTOP

To prevent the cooktop from discoloring or staining:

- Clean cooktop after each use.
- Wipe acidic or sugary spills as soon as the cooktop has cooled as these spills may discolor the porcelain.

SEALED BURNERS

The sealed burners of your cooktop are secured to the cooktop and are not designed to be removed. Since the burners are sealed into the cooktop, boilovers or spills will not seep underneath the cooktop. However, the burner heads should be cleaned after each use. (See page 9 for cleaning directions.)

BURNER GRATES

The grates must be properly positioned before cooking. Improper installation of the grates may result in chipping of the cooktop.

Do not operate the burners without a pan on the grate. The grate's porcelain finish may chip without a pan to absorb the heat from the burner flame.

Although the burner grates are durable, they will gradually lose their shine and/or discolor, due to the high temperatures of the gas flame.

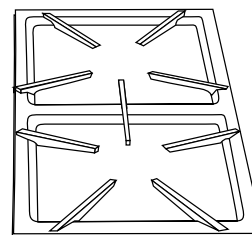

USING YOUR COOKTOP

Surface Controls

⚠ CAUTION

- If flame should go out during a cooking operation, turn the burner off. If a strong gas odor is detected, open a window and wait five minutes before relighting the burner.
- Be sure all surface controls are set to the **OFF** position prior to supplying gas to the cooktop.
- **NEVER** touch cooktop until it has cooled. Expect some parts of the cooktop, especially around the burners, to become warm or hot during cooking. Use potholders to protect hands.

Surface Control Knobs

Use to turn on the surface burners. An infinite choice of heat settings is available from **Lo** to **Hi**. At the **Hi** setting a detent or notch may be felt.



Pilotless Ignition

Pilotless ignition eliminates the need for a constant standing pilot light. Each surface burner has a spark ignitor. Use care when cleaning around the surface burner.

If the surface burner does not light, check if ignitor is broken, soiled or wet.

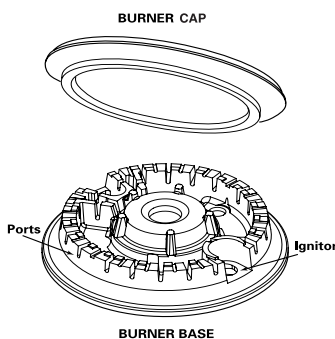

Setting the Controls

Your cooktop has sealed gas burners with automatic re-ignition. If the burner flame should go out, the system will automatically spark to re-ignite the burner.

1. Place a pan on the burner grate. (To preserve the grate finish, do not operate the burners without a pan on the grate to absorb the heat from the burner flame.)
2. Push in knob and turn immediately counterclockwise to the desired setting.
 - A clicking (spark) sound will be heard and the burner will light. (All ignitors will spark when any surface burner knob is turned on. However, only the selected burner will light.)

Operating During a Power Failure

1. Hold a lighted match to the desired surface burner head.
2. Push in and turn the control knob slowly to the desired setting.

⚠ CAUTION

- When lighting the surface burners, be sure all of the controls are in the **OFF** position. Strike the match first and hold it in position before turning the knob.
- **Do not** leave the cooktop unattended when cooking during a power failure. The automatic re-ignition feature will not operate during a power failure.

Suggested Heat Settings

The size and type of cookware will affect the heat setting. For information on cookware and other factors affecting heat settings, refer to "Cooking Made Simple" booklet.

SETTINGS	USES
<p>Hi</p>	<p>Use Hi to bring liquid to a boil, or reach pressure in a pressure cooker. Always reduce setting to a lower heat when liquids begin to boil or foods begin to cook.</p> <p>An intermediate flame size is used to continue cooking. Food will not cook any faster when a higher flame setting is used than needed to maintain a gentle boil. Water boils at the same temperature whether boiling gently or vigorously.</p>
<p>Lo</p>	<p>Use Lo to simmer foods, keep foods warm and melt chocolate or butter.</p> <p>Some cooking may take place on the Lo setting if the pan is covered. It is possible to reduce the heat by rotating the knob toward OFF. Be sure flame is stable.</p>

USING YOUR COOKTOP

Cooktop at a Glance

MODEL JGC8536

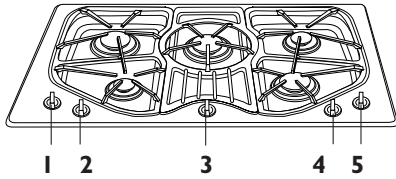

1. Left rear surface burner (9,200 BTUs).
2. Left front surface burner (5,000 BTUs on **Hi**, 650 BTUs on **Lo**).
3. Center surface burner (15,000 BTUs).
4. Right front surface burner (12,500 BTUs).
5. Right rear surface burner (5,000 BTUs on **Hi**, 650 BTUs on **Lo**).

MODEL JGC8430B

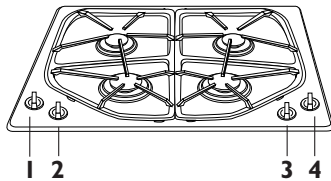

1. Left rear surface burner (10,500 BTUs).
2. Left front surface burner (5,000 BTUs on **Hi**, 650 BTUs on **Lo**).
3. Right front surface burner (15,000 BTUs).
4. Right rear surface burner (9,200 BTUs).

To prevent the cooktop from discoloring or staining:

- Clean cooktop after each use.
- Wipe acidic or sugary spills as soon as the cooktop has cooled as these spills may discolor the surface.

Sealed Burners

The sealed burners are secured to the cooktop and are not designed to be removed. Since the burners are sealed into the cooktop, boilovers or spills will not seep underneath the cooktop.

However, the burners should be cleaned after each use. The head portion of the burner is easily removed for cleaning. (See page 7 for cleaning directions.)

Burner caps must be correctly placed on the burner base for proper operation of the burner.

High Performance Burner*

There is one high speed burner on your cooktop, located in the center or right front position. This burner offers higher speed cooking that can be used to quickly bring water to a boil and for large-quantity cooking.

Simmer Burners*

These burners are located in the left front position and/or the right rear position. The simmer burner offers a lower BTU flame for delicate sauces or melting chocolate.

* BTU ratings will vary when using LP gas.

Burner Grates

The grates must be properly positioned before cooking. Improper installation of the grates may result in chipping of the cooktop. To ensure proper positioning, align bumpers on grate bottom with the indentations in the cooktop.

Do not operate the burners without a pan on the grate. The grate's porcelain finish may chip without a pan to absorb the heat from the burner flame.

Although the burner grates are durable, they will gradually lose their shine and/or discolor, due to the high temperatures of the gas flame.

Notes :

- A properly adjusted burner with clean ports will light within a few seconds. If using natural gas, the flame will be blue with a deeper blue inner cone.

If the burner flame is yellow or is noisy, the air/gas mixture may be incorrect. Contact a service technician to adjust. (Adjustments are not covered by the warranty.)

With LP gas, some yellow tips on the flames are acceptable. This is normal and adjustment is not necessary.

- With some types of gas, you may hear a "popping" sound when the surface burner is turned off. This is a normal operating sound of the burner.
- To improve cooking efficiency and to prevent possible damage to the cooktop or pan, the flame must be adjusted so it does not extend beyond the edge of the pan.

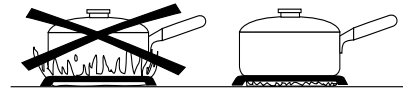

USING YOUR COOKTOP

Surface Controls

⚠ CAUTION

- If flame should go out during a cooking operation, turn the burner off. If a strong gas odor is detected, open a window and wait five minutes before relighting the burner.
- Be sure all surface controls are set to the **OFF** position prior to supplying gas to the cooktop.
- **NEVER** touch cooktop until it has cooled. Expect some parts of the cooktop, especially around the burners, to become warm or hot during cooking. Use potholders to protect hands.

Surface Control Knobs

Use to turn on the surface burners. An infinite choice of heat settings is available from **Lo** to **Hi**. At the **Hi** setting a detent or notch may be felt. The knobs can be set on or between any of the settings.

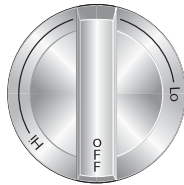

Setting the Controls

Your cooktop has sealed gas burners with automatic re-ignition. If the burner flame should go out, the system will automatically spark to re-ignite the burner.

1. Place a pan on the burner grate. (To preserve the grate finish, do not operate the burners without a pan on the grate to absorb the heat from the burner flame.)
2. Push in knob and turn immediately counterclockwise to the desired setting.
 - A clicking (spark) sound will be heard and the burner will light. (All ignitors will spark when any surface burner knob is turned on. However, only the selected burner will light.)

Operating During a Power Failure

1. Hold a lighted match to the desired surface burner head.
2. Push in and turn the control knob slowly to the desired setting.

⚠ CAUTION

- When lighting the surface burners, be sure all of the controls are in the **OFF** position. Strike the match first and hold it in position before turning the knob.
- **Do not** leave the cooktop unattended when cooking during a power failure. The automatic re-ignition feature will not operate during a power failure.

Suggested Heat Settings

The size and type of cookware will affect the heat setting. For information on cookware and other factors affecting heat settings, refer to “**Cooking Made Simple**” booklet.

SETTINGS	USES
<p>Hi</p>	<p>Use Hi to bring liquid to a boil, or reach pressure in a pressure cooker. Always reduce setting to a lower heat when liquids begin to boil or foods begin to cook.</p> <p>An intermediate flame size is used to continue cooking. Food will not cook any faster when a higher flame setting is used than needed to maintain a gentle boil. Water boils at the same temperature whether boiling gently or vigorously.</p>
<p>Lo</p>	<p>Use Lo to simmer foods, keep foods warm and melt chocolate or butter.</p> <p>Some cooking may take place on the Lo setting if the pan is covered. It is possible to reduce the heat by rotating the knob toward OFF. Be sure flame is stable.</p>

USING YOUR COOKTOP

Cooktop at a Glance

MODEL JGC8645

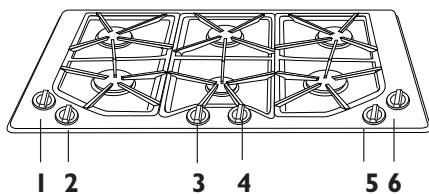

1. Left rear surface burner (10,500 BTUs).
2. Left front surface burner (9,100 BTUs).
3. Center rear surface burner (6,500 BTUs on **Hi**, 850 BTUs on **Lo**).
4. Center front surface burner (6,500 BTUs on **Hi**, 850 BTUs on **Lo**).
5. Right front surface burner (15,000 BTUs).
6. Right rear surface burner (9,100 BTUs).

To prevent the cooktop from discoloring or staining:

- Clean cooktop after each use.
- Wipe acidic or sugary spills as soon as the cooktop has cooled as these spills may discolor the porcelain.

Sealed Burners

The sealed burners are secured to the cooktop and are not designed to be removed. Since the burners are sealed into the cooktop, boilovers or spills will not seep underneath the cooktop.

However, the burners should be cleaned after each use. The head portion of the burner is easily removed for cleaning. (See page 7 for cleaning directions.)

High Performance Burner (15,000 BTUs*)

There is one high speed burner on your cooktop, located in the right front position. This burner offers higher speed cooking that can be used to quickly bring water to a boil and for large-quantity cooking.

Simmer Burners (850 BTUs*)

These burners are located in the center positions. The simmer burners offer a lower BTU flame for delicate sauces or melting chocolate.

** BTU ratings will vary when using LP gas.*

Burner Grates

The grates must be properly positioned before cooking. Improper installation of the grates may result in chipping of the cooktop.

Do not operate the burners without a pan on the grate. The grate's porcelain finish may chip without a pan to absorb the heat from the burner flame.

Although the burner grates are durable, they will gradually lose their shine and/or discolor, due to the high temperatures of the gas flame.

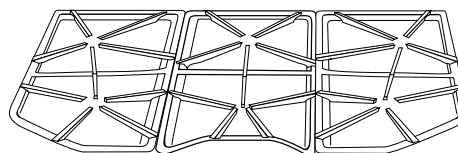

Notes:

- A properly adjusted burner with clean ports will light within a few seconds. If using natural gas, the flame will be blue with a deeper blue inner cone.

If the burner flame is yellow or is noisy, the air/gas mixture may be incorrect. Contact a service technician to adjust. (Adjustments are not covered by the warranty.)

With LP gas, some yellow tips on the flames are acceptable. This is normal and adjustment is not necessary.

- With some types of gas, you may hear a "popping" sound when the surface burner is turned off. This is a normal operating sound of the burner.
- To improve cooking efficiency and to prevent possible damage to the cooktop or pan, the flame must be adjusted so it does not extend beyond the edge of the pan.

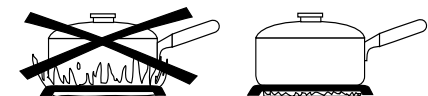

Care and Cleaning

CARE & CLEANING

CLEANING PROCEDURES

CAUTION:

- Be sure appliance is off and all parts are cool before handling or cleaning. This is to avoid damage and possible burns.
- To prevent staining or discoloration, clean appliance after each use.
- If a part is removed, be sure it is correctly replaced.

CONTROL KNOBS

- Remove knobs in the OFF position by pulling up.
- Wash, rinse and dry. Do not use abrasive cleaning agents as they may scratch the finish.
- Turn on each burner to be sure the knobs have been correctly replaced.

SEALED BURNER CARTRIDGE - PORCELAIN ENAMEL

Porcelain enamel is glass fused on metal and may crack or chip with misuse. It is acid resistant, not acid proof. All spillovers, especially acidic or sugary spillovers, should be wiped up immediately with a dry cloth.

- When cool, wash with soapy water, rinse and dry.
- Never wipe off a warm or hot surface with a damp cloth. This may cause cracking or chipping.
- Never use oven cleaners, abrasive or caustic cleaning agents on exterior finish of range.

SEALED GAS BURNERS/GRATES

- Allow burner and grates to cool. Wash with soapy water and a plastic scouring pad. For stubborn soils, clean with a soap-filled, non-abrasive pad or a sponge and a commercial Cooktop Cleaning Creme (Part#20000001)**.
- Clean gas ports with a soft bristle brush or a straight pin especially the port below the ignitor. Do not enlarge or distort holes.
- Be careful not to get water into burner ports.
- When cleaning, use care to prevent damage to the ignitor. If the ignitor is soiled, wet or damaged the surface burner will not light.

STAINLESS STEEL

- **DO NOT USE ANY CLEANING PRODUCT CONTAINING CHLORINE BLEACH.**
- **ALWAYS WIPE WITH THE GRAIN WHEN CLEANING.**
- **Daily Cleaning/Light Soil** — Wipe with one of the following - soapy water, white vinegar/water solution, Formula 409 Glass and Surface Cleaner* or a similar multi-surface cleaner - using a sponge or soft cloth. Rinse and dry. To polish and help prevent fingerprints, follow with Stainless Steel Magic Spray (Jenn-Air Model A912, Part No. 20000008)**.
- **Moderate/Heavy Soil** — Wipe with one of the following - Bon Ami*, Smart Cleanser*, or Soft Scrub* - using a damp sponge or soft cloth. Rinse and dry. Stubborn soils may be removed with a damp Scotch-Brite* pad; rub evenly with the grain. Rinse and dry. To restore luster and remove streaks, follow with Stainless Steel Magic Spray.
- **Discoloration** — Using a damp sponge or soft cloth, wipe with Cameo Stainless Steel Cleaner*. Rinse immediately and dry. To remove streaks and restore luster, follow with Stainless Steel Magic Spray.

GRILL ASSEMBLY —

BASIN — PORCELAIN

The basin is located under the grill burner and/or cartridges. Clean after each use of the grill.

- To remove light soil, clean with soapy water or spray with cleansers such as Fantastik* or Formula 409*. For easier cleanup: **a)** spray with a household cleanser; **b)** cover with paper towels; **c)** add small amount of hot water to keep the paper towels moist; **d)** cover and wait 15 minutes; and **e)** wipe clean.
- To remove moderate soil, scrub with Bon Ami*, a soft scrub cleanser or plastic scrubber.

Note: Check the grease drain after each use of the grill. To clean: Pour about 1/3 cup of very hot tap water mixed with 1 teaspoon dish detergent down the drain.

GRATES — CAST ALUMINUM COATED WITH NON-STICK FINISH

- Wash cool grates (DO NOT IMMERSE HOT GRILL GRATES IN WATER) with detergent in hot water in the sink or wash them in the dishwasher. Be sure to remove all food residue before cooking on the grill grates again.
- Remove stubborn soils with a plastic mesh puff or pad. Use only those cleaning products which state they are recommended for use when cleaning nonstick surfaces.
- If grates were washed in the dishwasher, season with oil prior to grilling.
- Do not use metal brushes or abrasive scouring pads or other scrubbers intended to clean outdoor charcoal grills. These will remove the finish as well as scratch the grates. Do not clean in self-cleaning oven or use oven cleaners on the grates.

GRILL BURNER

- Follow instructions on page 6 for removing the grill burner.
- The grill burner should be cleaned after each use with a soapy S.O.S.* pad. Rinse and dry thoroughly before using again.

NOTE: Check to be sure all burner ports are open. To open clogged ports, insert a straight pin into each port.

GREASE DRAIN JAR

- A drain jar is located below the grill basin pan under the countertop. Check periodically to prevent spillovers. Unscrew to remove.

- If jar is broken, replace with any heat tempered jar, such as a canning jar, which has a standard screw neck.



* Brand names for cleaning products are registered trademarks of the respective manufacturers.

** To order direct, call 1-800-688-8408.

Appendix C

Converting from Natural Gas to L.P. Gas

WARNING

To avoid risk of electrical shock, personal injury or death; disconnect power to cooktop before servicing, unless testing requires power.

Converting from Natural Gas to LP Gas

Converting the Burner Orifice Spuds

1. Remove the grates and burner caps.
2. Remove burner base by removing 2 screws.
3. Trim a small piece of masking tape to the size of a dime and place it over the end of a 9/32" (or 7mm) nut driver.
4. Firmly press the nut driver over the orifice spud and loosen spud by turning counterclockwise. Carefully lift the nut driver out of the burner throat. Orifice spud should be captured in the recess. Repeat this step for each burner.
5. Locate the LP orifice spud packet taped to the underside of the burner box. The spuds have small numbers stamped on the side. This number codes the orifice diameter and its correct burner location.

NOTE: See chart and graphics below for location of components.

6. With the masking tape still in place in the recess of the nut driver, press an LP orifice spud into the recess so that it is snugly captured.
7. Carefully install the orifice spud in the appropriate burner throat by turning clockwise to tighten.
8. Tighten to a torque of orifice 15 to 20 inch-lbs.
9. Replace burner base. Tighten screws to 25-30 inch-lbs.
10. Repeat steps 2 through 9 for each burner.
11. Replace burner caps and grates.
12. Save orifices removed from appliance for future use.

Model JGD8348CDP

Orifice Spuds			
LP (burner)	Orifice color (#)	Natural Gas (burner)	Orifice color (#)
9K (CF)	Blue (#63)	10K (CF)	Brass (#53)
9K (RF)	Blue (#63)	10K (RF)	Brass (#53)
6.5K (CR)	Red (#68)	10K (CR)	Brass (#53)
6.5K (RR)	Red (#68)	10K (RR)	Brass (#53)
7.5K (LF)	Zinc (#66)	8K (LF)	Green (#55)
7.5K (LR)	Zinc (#66)	8K (LR)	Green (#55)

Models JGCP430ADP, JGCP636ADP, JGCP648ADP

Orifice Spuds			
LP (burner)	Orifice #	Natural Gas (burner)	Orifice color
9.1K (CF)	#94	9.2K (CF)	Red
15K (RF)	#117	17K (RF)	Gold
9.1K (RR)	#94	9.2K (RR)	Red
15K (LF)	#117	17K (LF)	Gold
4K (LR)	#64	5K (LR)	Blue

Converting Pressure Regulator for LP/Propane

1. Remove pressure regulator cap using a wrench.
2. Apply sideward finger pressure to remove pin from cap.

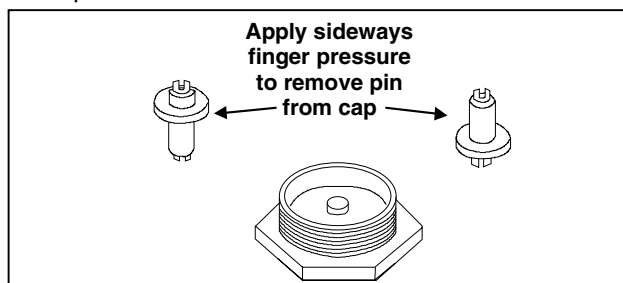

3. Apply downward finger pressure at the disc edges to place pin into the cap.

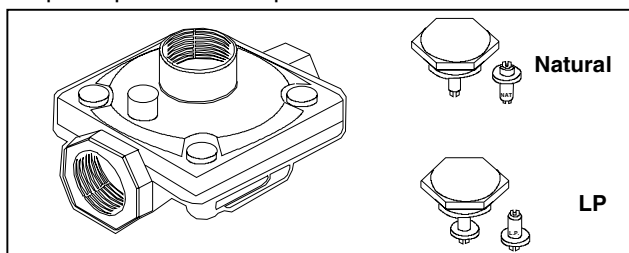

4. Place pressure regulator cap on pressure regulator and tighten.

Low Flame Adjustment

Properly adjusted burner flames are clean and blue with a distinct inner cone approximately 1/2 inch long.

1. Light burner and set control knob for low flame.
2. Remove control knob from valve stem.
3. Insert a slender thin bladed screwdriver into the recess at center of valve stem and engage blade with slot in adjusting screw.
4. Turn adjusting screw clockwise until tight. Do not over tighten.
 - Clockwise to decrease
 - Counterclockwise to increase
5. Repeat process for remaining burners.

After adjusting the screw, the burner should produce a stable, steady blue flame of minimum size. The setting should be checked by turning the knob from high to low several times without extinguishing the flame.

This operation will automatically provide the proper flame size at medium setting.

After conversion steps have been completed, check the appearance of each burner flame at high and low settings. If the flames appear too large or small, review each step to verify it was completed correctly.

LP/Natural Gas Conversion JGC8430BD*, JGC8645BDS

Converting from Natural Gas to L.P. Gas



WARNING

To avoid risk of electrical shock, personal injury or death; disconnect power to cooktop before servicing, unless testing requires power.

Converting from Natural Gas to LP Gas

Converting the Burner Orifice Spuds

1. Remove the grates and burner caps.
2. Remove venture tube or burner base by removing 2 screws.
3. Trim a small piece of masking tape to the size of a dime and place it over the end of a 5/16" or a 9/32" (7mm) nut driver.
4. Firmly press the nut driver over the orifice spud and loosen spud by turning counterclockwise. Carefully lift the nut driver out of the burner throat. Orifice spud should be captured in the recess. Repeat this step for each burner.
5. Locate the LP orifice spud packet taped to the underside of the burner box. The spuds have small numbers stamped on the side. This number codes the orifice diameter and its correct burner location.

NOTE: See chart and graphics below for location of components.

6. With the masking tape still in place in the recess of the nut driver, press an LP orifice spud into the recess so that it is snugly captured.
7. Carefully install the orifice spud in the appropriate burner throat by turning clockwise to tighten.
8. Tighten to a torque of orifice 15 to 20 inch-lbs.
9. Replace burner base. Tighten screws to 25-30 inch-lbs.
10. Repeat steps 2 through 9 for each burner.
11. Replace burner caps and grates.
12. Save orifices removed from appliance for future use.

Model JGC8645BDS

Orifice Spuds			
Natural Gas (burner)	Orifice color or #	LP (burner)	Orifice #
6.5K (CF)	Silver	5K (CF)	# 70
15K (RF)	# 49	8.5K (RF)	# 65
6.5K (CR)	Silver	5K (CR)	# 70
9.1K (RR)	Green	5.5K (RR)	# 69
9.1K (LF)	Green	5.5K (LF)	# 65
10.5K (LR)	Yellow	8.5K (LR)	# 69

Model JGC8430BD*

Orifice Spuds			
Natural Gas (burner)	Orifice #	LP (burner)	Orifice #
15K (RF)	# 190	14K (RF)	# 114
9.2K (RR)	# 145	9.1K (RR)	# 91
5K (LF)	# 107	4K (LF)	# 64
10.5K (LR)	# 155	9K (LR)	# 91

Converting Pressure Regulator for LP/Propane

1. Remove pressure regulator cap using a wrench.
2. Apply sideward finger pressure to remove pin from cap.

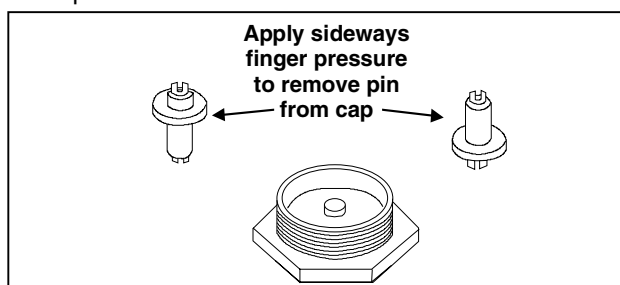

3. Apply downward finger pressure at the disc edges to place pin into the cap.

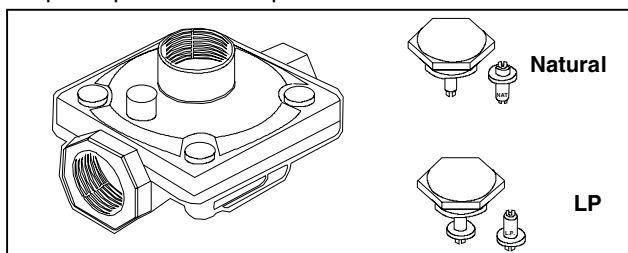

4. Place pressure regulator cap on pressure regulator and tighten.

Low Flame Adjustment

Properly adjusted burner flames are clean and blue with a distinct inner cone approximately 1/2 inch long.

1. Light burner and set control knob for low flame.
2. Remove control knob from valve stem.
3. Insert a slender thin bladed screwdriver into the recess at center of valve stem and engage blade with slot in adjusting screw.
4. Turn adjusting screw clockwise until tight. Do not over tighten.
 - Clockwise to decrease
 - Counterclockwise to increase
5. Repeat process for remaining burners.

After adjusting the screw, the burner should produce a stable, steady blue flame of minimum size. The setting should be checked by turning the knob from high to low several times without extinguishing the flame.

This operation will automatically provide the proper flame size at medium setting.

After conversion steps have been completed, check the appearance of each burner flame at high and low settings. If the flames appear too large or small, review each step to verify it was completed correctly.