

MAYTAG

Maytag

**Gas and Electric Range
Service Manual**

**30" Freestanding
(non-downdraft)
1997 thru present**

16010161
Issued 8/00

Contents

General Safety Precautions	i
Introduction	ii
The Vantage Range Series	ii
Model / Serial Plate	iii
Wiring Information	iii
Items packed with the product	iii
Warranty Registration Card	iv
User's Guide (Use & Care Manual)	iv
Literature Pack	iv
Half Rack	iv
Cleaning Products	iv
Anti-Tip Device	v
Installation	vi
Range Connections	vi
1. General Trouble Shooting	1-1
General Procedures	1-1
Electrical component testing	1-1
Grounding and polarity	1-2
Test Equipment	1-3
Troubleshooting Flow Charts	1-4
T1 and T2 Electronic Oven Controls	1-7
Membrane keypad:	1-7
Data input T1 control	1-7
Data input T2 control	1-7
Bake, Electric Ranges for T1	1-7
Bake, Electric Ranges for T2	1-7
Broil, Electric Ranges for T1	1-8
Broil, Gas Range for T1 & T2	1-8
Bake, Gas Ranges for T1	1-8
Bake, Gas Ranges for T2	1-8
Broil, Variable, Electric Range for T2	1-8
Convection Bake, Electric Ranges for T1	1-8
Convection Bake, Electric Ranges for T2	1-9
Convection Bake, Gas Ranges for T1	1-9
Convection, Dual Speed, Electric Slide in Ranges Only for T1 & T2	1-9
Drying, Slide-In Electric Ranges Models Only for T1	1-9
Drying, Gas Slide-In Ranges for T1	1-9
Drying, Electric Ranges for T2	1-9
Drying, Gas Ranges for T2	1-10
Clean, Electric Ranges for T1 & T2	1-10
Clean, Gas Ranges for T1 & T2	1-10
Motorized Door Lock for T1 & T2	1-10
Ranges with Manual Door Lock T1 & T2	1-10
Fault Codes for T1 & T2:	1-11
Oven Temperature Adjustment for T1	1-12
Oven Temperature Adjustment for T2	1-12
Demo Mode for T2	1-12

1. General Troubleshooting con't

Twelve Hour Energy Saving Mode Cancellation for T1	1-12
Twelve Hour Energy Saving Mode Cancellation for T2.....	1-12
Control Lockout for T1	1-12
Control Lockout for T2	1-12
Clock Display Disable for T1 & T2	1-13
End of Timer Reminder Options for T2	1-13
Oven Temperature Sensor, Value Chart	1-13
Oven Temperature Sensor, Value Chart	1-13
Oven Temperature Sensor,	1-13
Value Chart for T2 Controls	1-13
Oven Temperature Sensor,	1-13
Value Chart for T1 Controls	1-13
RS1 Electronic Oven Control	1-14
Control Features	1-14
Slew Entry	1-14
Bake Cycle, Electric Ranges	1-14
Bake Cycle, Gas Range	1-14
Broil Cycle, Electric Ranges	1-14
Broil Cycle, Gas Ranges	1-14
Oven Temperature Adjustment	1-15
Twelve Hour Energy Saving Mode	1-15
50/60 Hz Operating Frequency	1-15
Keypad Entry	1-15
Oven Temperature Sensor, Value Chart	1-15
Oven Temperature Sensor,	1-15
Value Chart for RS1 Controls	1-15
2. General Component Access	2-1
Electrical Safety	2-1
Service Procedure	2-1
Electrical Supply	2-1
Outside Wiring	2-2
House Wiring	2-2
General Component Placement	2-3
Oven Door Removal	2-4
Door Locked (Inoperable Latch)	2-4
Door and Base Drawer Assembly Breakdown	2-5
Removing Top Assembly (Electric)	2-6
Removing Top Assembly (Gas)	2-7
Sealed Burner Wrench	2-7
Sealed burner Removal	2-8
Removing the Top (Gas)	2-9
Top Clips (Gas)	2-10
Removing Door Latch Assembly (Electric & Gas)	2-11
Backguard Access (Electric & Gas)	2-12
Range Back Removal/Components (Electric)	2-13
Door Light Switch and Hinge Removal	2-14
Spark Module Location.....	2-15

Oven Cavity Components (Electric)	2-16
Convect Fan Motor and Blade (Electric & Gas)	2-17
Oven Light (Electric & Gas)	2-18
Manifold Panel Removal	2-19
Valves and Swithes (Gas).....	2-20
Valve Seals	2-21
Oven Bottom Removal	2-21
Bake Burner	2-21
Broil Burner	2-22
Oven Burner Adjustments	2-22
Top Burner Adjustments	2-22
Appliance Regulator and Oven Valve Location.....	2-23
Gas Pressure	2-24
Gas Supply Connections	2-24
Gas Conversion	2-24
Appliance Pressure Regulator Conversion	2-25
Orifice Conversion	2-26
3. General Component Testing	3-1
Line Voltage	3-1
Ground	3-1
Broil Power (electric models)	3-1
Bake Power (electric models)	3-1
Broil and Bake Power (gas models)	3-1
Latch & Convection Fan Power (motorized latch and convection models)	3-1
Auxiliary Fan Power (dual-speed convection and cooling blower models)	3-1
Temperature Sensor	3-1
Door Latch Unlocked (motorized latch models)	3-1
Keyboard	3-1
Model Options	3-1
Broil Element (electric models)	3-2
Broil Gas Valve (gas models)	3-2
Bake Gas Valve (gas models)	3-2
Convection Fan (convection models)	3-2
Auxiliary Fan (dual-speed convection	3-2
and cooling blower models)	3-2
Door Latch Motor (motorized	3-2
Latch Pulse	3-2
Double Link Break Relay Control	3-2
(Canadian models)	3-2
Display	3-2
Audio Annunciator	3-2
Fused Neutral (Canadian models)	3-2
Maximum Operating Conditions	3-8
Spark Ignition System.....	3-9
Glow Bar Ignition.....	3-10
Glow Bar Operating Parameters.....	3-10
Valve Igniter.....	3-10
Glow Bar Operation.....	3-10

4. Wiring and Model Specific Information 4-1

Jenn-Air Models:

JGR8750ADB JGR8750ADQ JGR8750ADW JGR8850ADB	
JGR8850ADQ JGR8850ADW JGR8855ADS	4-1
JER8750AAB JER8750AAQ JER8750AAW JER8850AAB	
JER8850AAQ JER8850AAW	
JER8855AAS	4-2
JER8850ACB JER8850ACW	4-3
JGW8130ADB.....	4-4
W132B W132W	4-5

Magic Chef Models:

CGR1320BDH CGR1320BDW CGR1330BDC CGR1330BDH	
CGR1330BDT CGR1420BDQ CGR1420BDW CGR1430BDH	
CGR1430BDT	4-6
CGR3520BDH CGR3520BDT.....	4-7
CGR3740BDH CGR3740BDT CGR3740BDW CGR3742BDC	
CGR3742BDQ CGR3742BDW	4-8
CGR3760BDB CGR3760BDQ CGR3760BDW CGR3765BDC	4-9
31000PAT 31000PAW	4-10
31100PAW 31100SAW	4-11
31203KAW 31203PAQ 31203PAV 31213XAW 31001PAT	
31001PAW 31001PAWP 31001SAT 31001SAW 31003SAW.....	4-12
CEP3540AAQ CEP3540AAW.....	4-13
CES3540AAC CES3540AAW	4-13
CEP3760AAB CEP3760AAQ CEP3760AAW CES3760AAB	
CES3760AAQ CES3760AAW.....	4-14
CER1110AAH CER1110AAT	4-15
CER1140AAQ CER1140AW CER1160AAH CER1160AAT	4-16
CER1360AAW	4-17
CER1360BCW.....	4-18
CER3520AAH CER3520AAT CER3540AAH CER3540AAQ	
CER3540AAT CER3540AAW	4-19
CER3540ACB CER3540ACW	4-20
CER3740AAH CER3740AAT	4-21
CER3760AAQ CER3760AAW.....	4-22
CER3765AAC	4-22
CER3760ACO CER3760ACW.....	4-23
CES1110AAH	4-24
CES1350AAH	4-25
CGS1230ADH CGS1230ADT	4-26
CGS1740ADH CGS1740ADT	4-27
CGS3760ACB CGS3760ADC CGS3760ADQ CGS3760ADW	4-28

Crosley Models:

CG34300ADT CG34300ADW	4-29
CG34700ADO CG34700ADV	4-30
C31000PAT C31000PAW C31100PAV C31100SAT C31100SATP C31100SAW C31100SAWP	4-31
C31103SAT C31103SAW C31113WAT C31113WATP C31113WAV C31113WAVP C31113XAT C31113XAW	4-32
C31315VBQ	4-33
C31315VBV	4-34
CC35111BCV	4-35
CC38700ACV	4-36
CE35000AAT CE35000AAW	4-37
CE35100AAT CE35100AAW	4-38
CE35111AAQ CE35111AAT CE35111AAV CE35111AAW	4-39
CE38000AAT CE38000AAW CE38300AAV	4-40
CE38700AAQ CE38700AAV	4-41

Maytag Models:

MGR1100ACW	4-42
MER1320BDW	4-43
MGR4410BDQ MGR4410BDW MGR4450BDQ MGR4450BDW	4-44
MGR5710ADW MGR5720ADH MGR5720ADT MGR5729ADH MGR5729ADQ MGR5729ADT MGR5729ADW MGR5730ADH MGR5730ADQ MGR5730ADW	4-45
MGR5750ADQ MGR5750ADW	4-46
MGR5755ADB MGR5755ADQ MGR5755ADW	4-47
MGR5770ADB MGR5770ADQ MGR5770ADW MGR5775ADB MGR5775ADQ MGR5775ADW MGR5870ADB MGR5870ADQ MGR5870ADW	4-48
PGR4410ADQ PGR4410ADW	4-49
MEP5770AAB MEP5770AAW	4-50
MER4110AAW	4-51
MER4320AAW	4-52
MER4530AAQ	4-53
MER4530AAW	4-53
MER4530BCW	4-54
MER5510AAT MER5510AAT	4-55
MER5530AAH MER5530AAW MER5530AAW	4-56
MER5530ACW	4-57
MER5550AAH MER5550AAQ MER5550AAW	4-58
MER5570ACQ MER5570ACW	4-59
MER5710AAW MER5730AAQ MER5730AAW	4-60
MER5730ACW	4-61
MER5730ACW MER5755AAQ MER5755AAW	4-62
MER5770AAB MER5770AAQ MER5770AAW	4-63
MER5770ACB MER5770ACW	4-64
MER5775AAB MER5775AAQ MER5775AAW	4-65

Wiring information in this manual was accurate at the time of manual production. Wiring information is subject to change at any time.
Please refer to wiring information on the actual product for most current information.

MER5870AAB MER5870AAQ MER5870AAW	4-66
MER5870ACB MER5870ACW	4-67
MES5570AAB	4-68
MES5770AAB MES5770AAQ MES5770AAW MES5870AAB MES5870AAQ MES5870AAW	4-69
MGS5770ADB MGS5770ADQ MGS5770ADW MGS5870ADB MGS5870ADQ MGS5870ADW	4-70
PER4510AAQ PER4510AAW	4-71

International Admiral Models:

ABR3740AGW	4-73
ALR1450AJW	4-74
A31000PAWT A31700PATT A31700PAWT A31700SAWL A31700XAWL	4-75
A31703SAWL A31713XATL A31713XAWL	4-76
AER1110AAH	4-77
AER1140AGH	4-78
AER1350AAH AER1350AAT	4-79
ARE1350AMH AER1360AGW	4-80
AER1450AAH	4-81
GA3170MPAW	4-82
GA3171SXAW GA3171WAV GA31713WAW	4-83

International Crosley Model:

CG3111SXAW	4-84
------------------	------

International Magic Chef Models:

GM3111GXAW GM3111SXAW GM31113WAV GM31211XAW	4-86
CER1360AGW	4-87
CER3520AGW	4-88
CBR3765AGC	4-89

International Maytag Models:

MBR4450BGH MBR4450BGW	4-90
MBR5750AGW	4-91
MLR4410BXH MLR4410BXT	4-92
MER4320AGH MER4320AGW	4-93
MER5730AGW	4-94
CRL5300DXT CRL5300DXW	4-95

International Norge Model:

NER1360AGH	4-96
------------------	------

International Dixie Models:

D31113XAT D31113XAWL	4-97
D31100PATL D31100PAWL	4-98

General Safety Precautions

Information contained in **this manual is intended for use by a qualified service technician**. The technician is required to be familiar with proper and safe procedures to be followed when repairing electric, gas, and microwave appliances. All tests and repairs are to be performed using proper tools and measuring devices designed for appliance diagnosis and repair. All component replacements should be made **using only factory approved replacement parts**.

Electrical shock and injury can result if service or repairs are attempted by an unqualified individual. **Improper disassembly, assembly or adjustments can create hazardous conditions.**

Even for a skilled technician, a risk of injury or electrical shock exists while performing service or repairs. **Electrical injury can be serious or fatal. Extreme caution must taken when performing voltage checks on individual components of an appliance.**

NOTE: Except as necessary to perform a particular step in servicing a product, the electrical power supply should always be disconnected when servicing a product.

To avoid possible injury, the appliance must be properly grounded. Never plug in or direct wire an appliance unless it is **properly grounded in accordance with all local and national codes.** See the installation instructions that originally accompanied the product for proper grounding procedures.

Important Safety Notice And Warning

The California Safe Drinking Water and Toxic Enforcement Act of 1986 (Proposition 65) requires the Governor of California to publish a list of substances known to the State of California to cause cancer or reproductive harm, and requires business to warn customers of potential exposures to such substances.

Introduction

The Vantage Range Series

This manual covers repair procedures for the Maytag Vantage series of gas and electric ranges. These include the following brand names: Maytag, Jenn-Air, Magic Chef, Crosley, Admiral and Norge.

The "Advanced Cooking System" oven with its dual-control elements, TempSense heat control and even heat distribution browns uniformly. Bakes consistently, without the typical hot or cool spots. The consumer should find no need to continually switch, turn and rearrange foods.



The Maytag range MER5870AAW shown above will be used to illustrate electric service procedures in this manual. The Maytag MGR5870ADW (not shown) will be used for gas related procedures. We have purposely selected these "high end" models to show as many of the features as possible. The range model you are servicing may not support all of these features.

This series of ranges include some or all (depending on model) of the following features:

- Dual-Control Bake and Broil Elements
- TempSense Control
- Electronic Oven Control
- Six-Pass Recessed Broil Element
- Four-Pass Recessed Broil Element
- Delay Start Cook Control
- Electronic Clock with Timer
- Convection Oven
- Dual Control Surface Radiant Elements
- Oven Light
- Oven Window
- Hot Surface Indicator Light(s)
- Chrome Oven Racks with 5 Levels
- Added Capacity Oven Half Rack
- Damage Resistant Cabinet
- Quiet Door Hinges
- Storage Drawer
- Recessed Drawer Handle
- Porcelain Enamel Broiler Pan
- Easy Clean Porcelain Back Panel
- Upswept Cooktop
- Self Clean Oven
- Automatic Self Clean Latch
- Control Lockout Option
- Drip Retainer Top
- Smooth Ceramic Glass top
- Removable High Wattage Coil Elements
- Lift up Top with Auto Prop Rods
- Tilt Bake Elements
- Pull off Knobs
- Power Gas burners
- Porcelain on Steel Burner Grates
- Cast Iron Burner Grates
- Waist High Broiler
- Lower Pull Out Broiler
- Precision Burner Controls
- LP convertible
- Sealed Surface Burners
- Lift Off Burner Caps

Model / Serial Plate

The Model / Serial plate is located at the bottom left side behind the service drawer on the front frame. The model number is very important to the technician for ordering parts both in and out of warranty. Always be sure to use the complete model number when ordering parts.

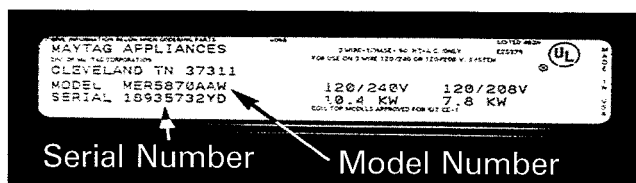

Serial plate enlarged and rotated to show detail. This information is important when calling tech support or ordering parts.

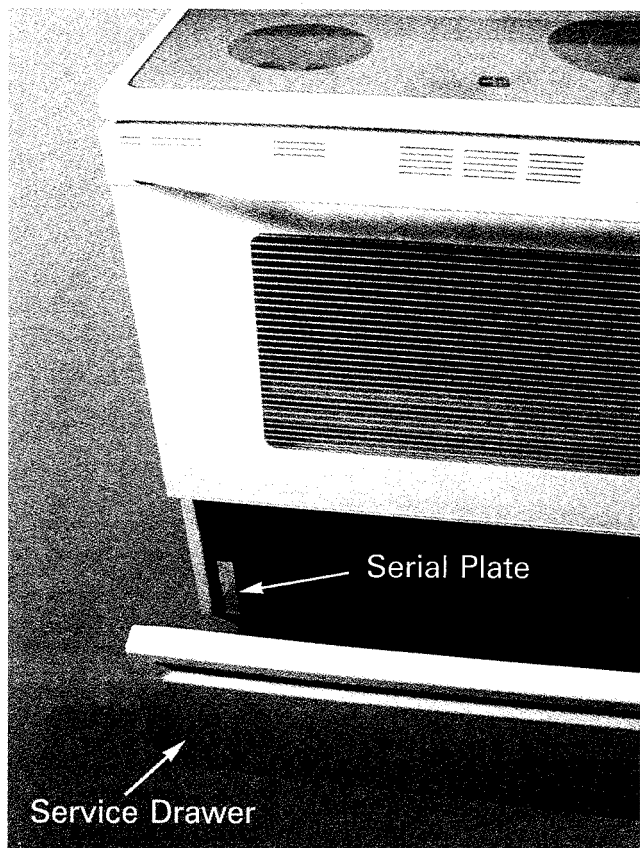

Serial Plate Location

! IMPORTANT
Unique product information for specific models is found in the wiring and model specific information section of this manual.

Wiring Information

A wiring diagram / schematic is supplied with the unit. It is attached to the rear right inside side panel of freestanding models and may be accessed by removed the service drawer. Please return the diagram to the storage compartment for future use.

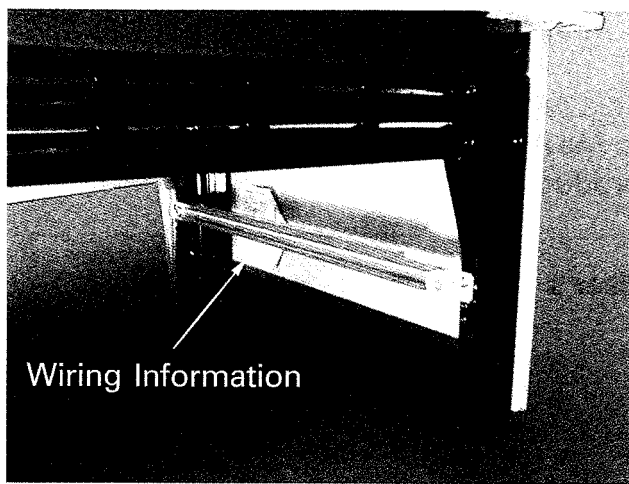

! IMPORTANT
Wiring information in this manual was accurate at the time of manual production. Wiring information is subject to change at any time. Please refer to wiring information on the actual product for most current information.

Items packed with the product

Many service calls are the result of the customer's lack of understanding as to the correct operation of the product. Several items are packed with the product to help avoid this situation. It sometimes becomes the servicer's obligation to explain the correct use and care of the appliance. Here we describe some of the items packaged with the product and their intent. Many of these pieces can be ordered from Maytag and may be of help in solving some service situations.

Warranty Registration Card

CONSUMER PRODUCT OWNERSHIP REGISTRATION
 Your prompt completion of this card will facilitate our contacting you in the unlikely event a safety modification is issued for your product under the consumer product safety act. (Applicable equipment for general use only)

Model No. _____ Serial No. _____

OWNER INFORMATION
 Name _____ Address _____ City _____ State _____ Zip _____

PHONE INFORMATION
 Home Phone _____ Office Phone _____

DEALER INFORMATION
 Name _____ Address _____ City _____ State _____ Zip _____

This card should be completed and returned to Maytag as soon after purchasing the product as possible.

User's Guide (Use & Care Manual)

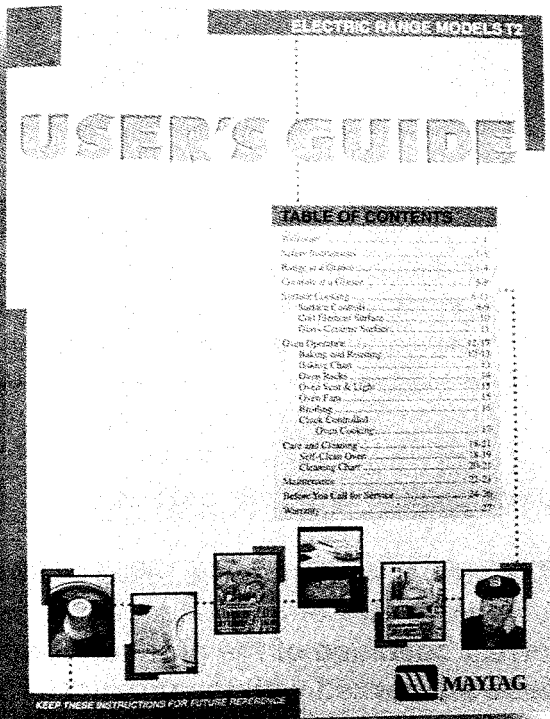

Probably the most useful tool to avoid unnecessary service calls. This book can be ordered through the Maytag Customer Service Literature department. Model and serial must be available when ordering.

Literature Pack

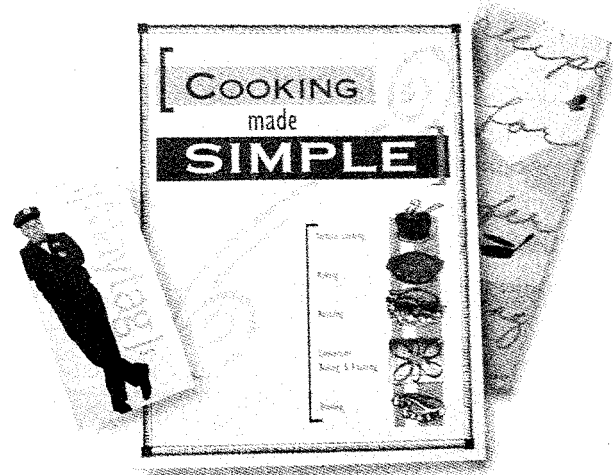

Half Rack

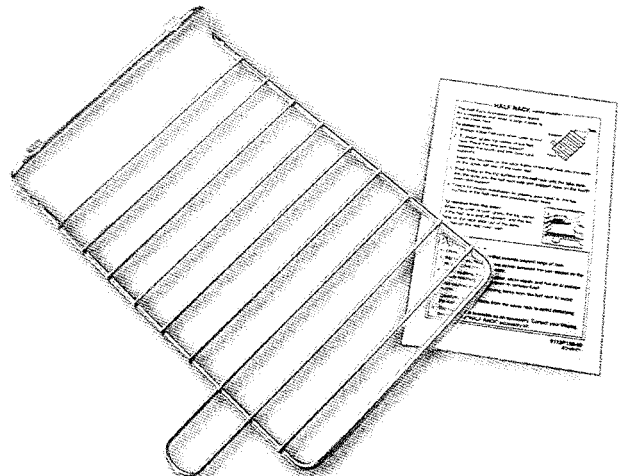

Cleaning Products



Installation Of Anti-Tip Device (UL Required)

Underwriters Laboratory requires that all electric ranges meet stringent anti-tip requirements. All free standing ranges, gas and electric, are being shipped from our factory with an anti-tip device. The device is included for our customer's safety. It is important that the device be properly attached during the installation of the unit in the customer's home. The installation procedure is simple and is detailed in the instructions that accompany each range.

To check the range for proper installation of the anti-tip bracket: Use a flashlight and look underneath the bottom of the range to see that one of the rear leveling legs is engaged in the bracket slot. When removing appliance for cleaning or servicing, be sure anti-tip device is engaged when range is replaced. The anti-tip device secures the rear leveling leg to the floor, when properly engaged.

If the anti-tip device has not been installed, inform the consumer to notify the installer for proper installation.

To order, Anti-Tip Installation Kit, use **part number 12400045.**

<i>Kit contains:</i>	Part #	Description	Qty.
	3801F218-51	Bracket	1
	7101P289-60	Screws	4
	16000582	Instruction Sheet	1

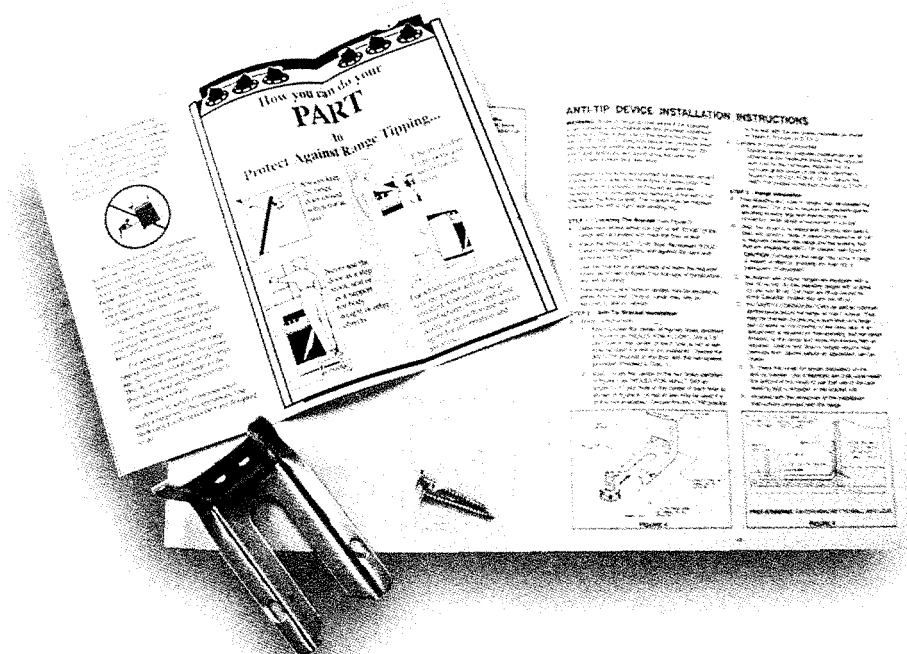

Installation

All freestanding ranges can be installed with the back against (0 inches) a vertical combustible wall, and the sides below the cooktop surface against (0 inches) combustible base cabinets. Some cabinets and building materials are not designed to withstand the heat produced by normal safe operation of a listed appliance. Discoloration or damage, such as delamination, may occur.

INSTALLER LEAVE THESE INSTRUCTIONS WITH THE APPLIANCE

INSTALLATION MANUAL

Electric 30-inch Free-standing, Slide-in & Drop-in Ranges

PLEASE KEEP THIS MANUAL FOR FUTURE REFERENCE
 THE MANUAL IS INTENDED TO ASSIST IN THE CORRECT INSTALLATION AND ADJUSTMENTS OF THE RANGE.

SPECIAL WARNING
 Only qualified personnel should install or service this range.
 Read "Safety Instructions" in the Use & Care book before using range.
 Improper installation, adjustment, alteration, service, maintenance or use of range can result in serious injury or property damage.

CLEARANCE DIMENSIONS
 For complete information regarding installation of free-standing, drop-in and slide-in ranges, see figures 1 through 4 on pages 8, 9 and 4. For SAFETY PRECAUTIONS, see related information from backlink document #9219-929-0 or consult with their installation customer sheet #1000.
CAUTION: Some cabinets and building materials are not designed to withstand the heat produced by the normal safe operation of a listed appliance. Discoloration or damage, such as delamination, may occur.

Your range may not be equipped with some of the features referred to in this manual.
 8101P225-00
 9219-929-0

Range Connections

Remember - Mobile homes and some local codes do not permit grounding through neutral. If this is the case a 4 wire service must be provided for such installations. All others permit 3 wire service. **Copper wire must be used exclusively.**

Note: For cord replacement - only a power-supply cord kit rated 240 volts minimum, 50 amperes, with closed loop terminals and marked for use with ranges must be used.

SLIDE-IN

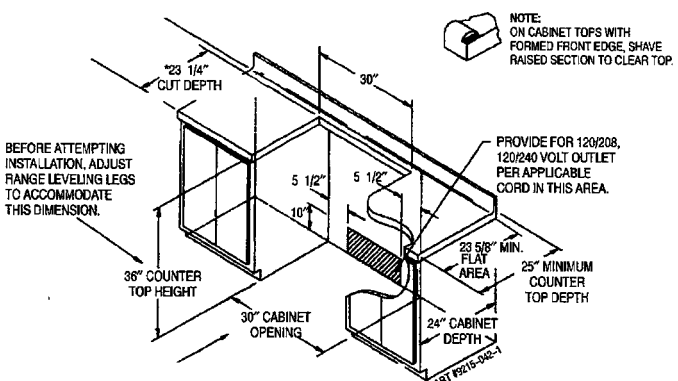

CAUTION:
 SOME WHITE EUROPEAN STYLE CABINETS ARE EQUIPPED WITH DELICATE WHITE VINYL DRAWER AND DOOR FRONTS. THE VINYL MAY NOT BE DESIGNED TO WITHSTAND THE HEAT PRODUCED BY THE NORMAL SAFE OPERATION OF A SELF-CLEAN RANGE. DISCOLORATION OR DELAMINATION MAY OCCUR. TO AVOID POSSIBLE DAMAGE WE RECOMMEND INCREASING THE 30" CABINET OPENING TO 31 1/4" MINIMUM AND USING HEAT SHIELD KIT-CABKIT V. THE COUNTERTOP CUT-OUT MUST REMAIN 30".

FREE-STANDING

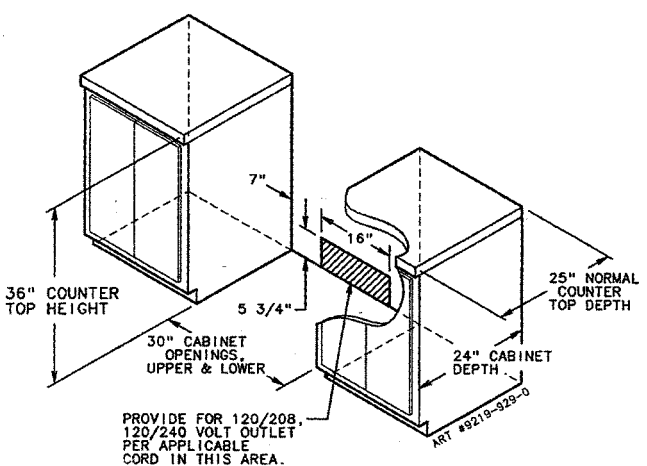

1. General Troubleshooting

General Procedures

This section is intended to assist you in diagnosing inoperative conditions which may develop in products manufactured by the Maytag corporation. Electrical testing is, for the most part, made with an appliance test meter and consists of checking for open or closed circuits. Mechanical checks are made through sight and sound, along with the use of a volt-wattmeter and clamp-on ammeter.

 ***This information is intended for the technician who is familiar with the operation and construction of Maytag products.***

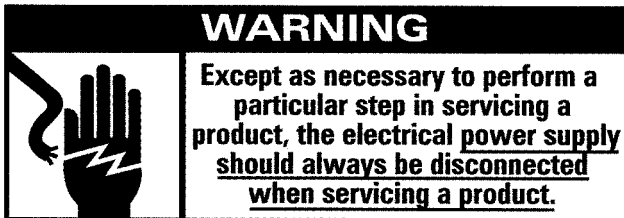

Electrical component testing

One of the easiest means of testing electrical components is "continuity testing" with a appliance test meter.

Continuity is a complete or continuous path from one point in an electrical circuit to another. Continuity testing, as related to an electrical component, is the checking of a part for an "open" or "closed" circuit. A continuity check can be performed once the product being tested has been disconnected from it's electrical supply and after appropriate wires have been removed from the terminals of the part being checked. Following manual activation of the part (if required) the probes of the test meter should be placed on the respective terminals. The readout from the test meter will indicate a completed (closed) circuit. Little or no value shown will indicate a broken or (open) circuit and a possible inoperative part.

Continuity testing is a process of eliminating those electrical components used in a given function of the product, until the inoperative part is found. By reviewing the list of possible electrical problems, under a given condition, and then performing appropriate continuity checks on the parts involved, you should be able to locate the electrical component which is inoperative.

Electrical components fall into two general categories:

1. **Loads** - Devices that **use** (consume) electricity. Examples would include fan motors, elements, lamps, solenoids etc.
2. **Switches** - Devices that **control** the supply of electricity to the load or loads in a circuit. Examples include lid switches, timer contacts , selector switch and relay contacts.

Continuity tests of "load" devices will show varying levels of resistance from very low for some transformer and motor windings to very high for some timer motors and components on electronic control boards. Usually it is more important to know if there is a path for current flow through a device (continuity) than to the exact resistance (ohms) of the device. Resistance values are included in this manual for your information.

For the most part, "loads" can be powered by using a motor test cord to confirm operation or failure. The motor test cord used in conjunction with a volt-watt meter will also show power required to operate the device. Continuity tests of switches will show virtually no resistance across closed contacts. Resistance even low values indicates burned or dirty contacts in a switch.

Grounding and polarity

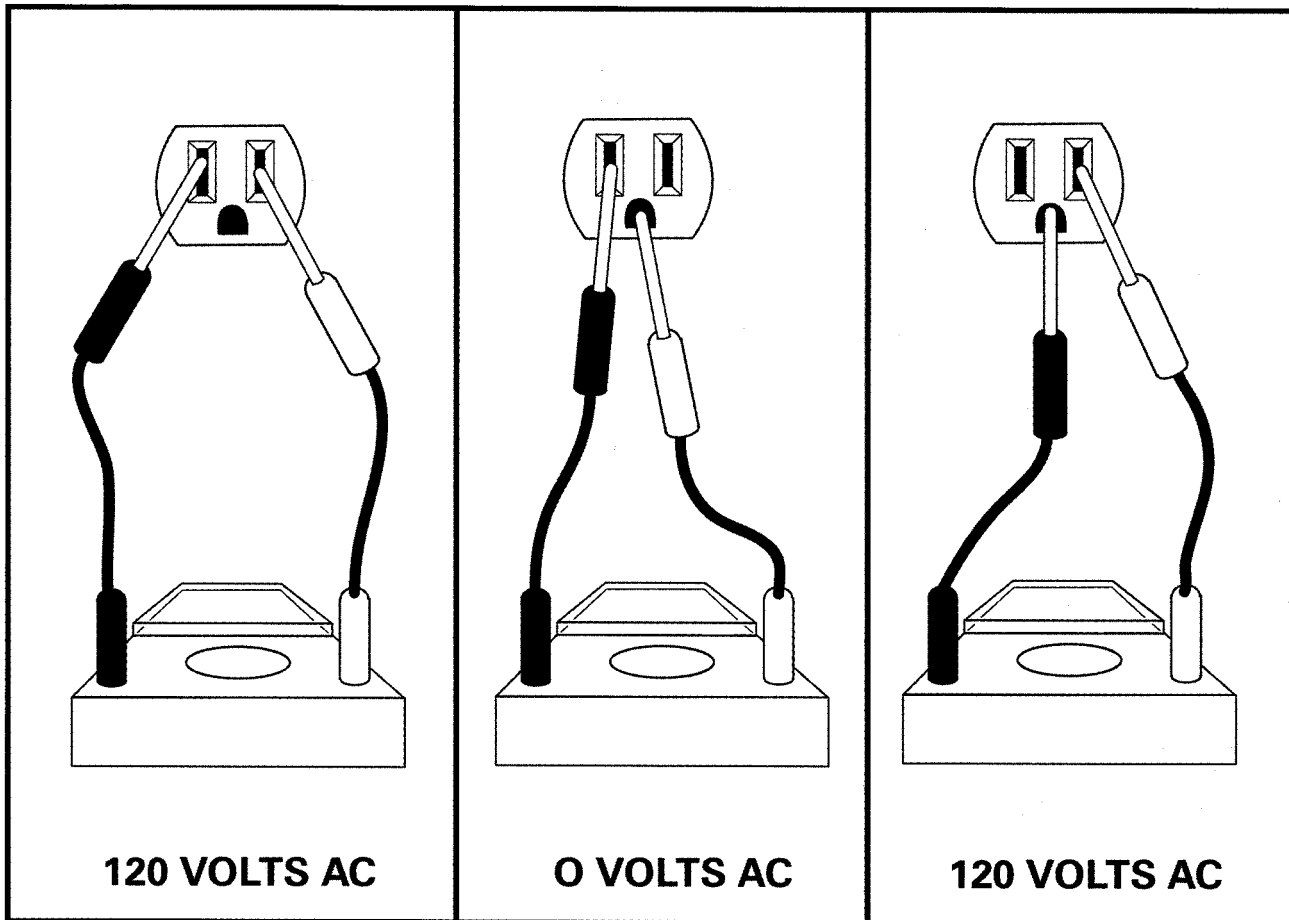

The above illustration shows a simple grounding and polarity check using a common appliance multimeter

⚠ IMPORTANT
Never alter or remove the grounding prong from the power cord. Use of grounding adapters is not recommended.

The receptacle used for all Maytag products operating on 120 VAC must be properly grounded and polarized.

The power cord used on the appliances is equipped with a three (3) prong polarized grounding plug for protection against shock hazard and should be plugged directly into a properly grounded and polarized receptacle.

It is the responsibility of the person installing the appliance to ensure it is adequately grounded and polarized at the point of in-

stallation. All local conditions and requirements must be taken into consideration.

In cases where only a two prong receptacle is available, it is the personal responsibility of the customer to have it replaced with a properly grounded and polarized 3 prong receptacle. All grounding and wiring should be done in accordance with national and local codes. ***Use of adapters is not recommended by Maytag*** unless the receptacle has been grounded through the center plate cover screw.

Test Equipment



1. 20001001 Digital Multi-Temp. Meter
 2. 20000005 Analog Test Meter
 3. 20000019 Volt-Watt Meter
 4. 20000066 Digital Capacitance Meter
 5. 20000002 Volt/Ohm/Ammeter
 (Digital Clamp Type)

6. 038221 Digital Photo Tachometer
 7. 038183 Electrical Test Cord
 8. 038709 Ne-O-Lite Test Light
 9. 20001006 Digital Multi-Meter
 10. 038205 Dwyer Flex Tube Manometer

Troubleshooting Flow Charts

The information in this section is intended for use by a Maytag authorized service technician. The **flowcharts describe general or common service scenarios** that may be helpful in determining the cause of the customer's complaint. This information is based on the assumption that the appliance is installed and being used correctly. ***The customer should be completely informed of any unsafe or improper condition that may effect the correct operation of the appliance.***

Will not Bake

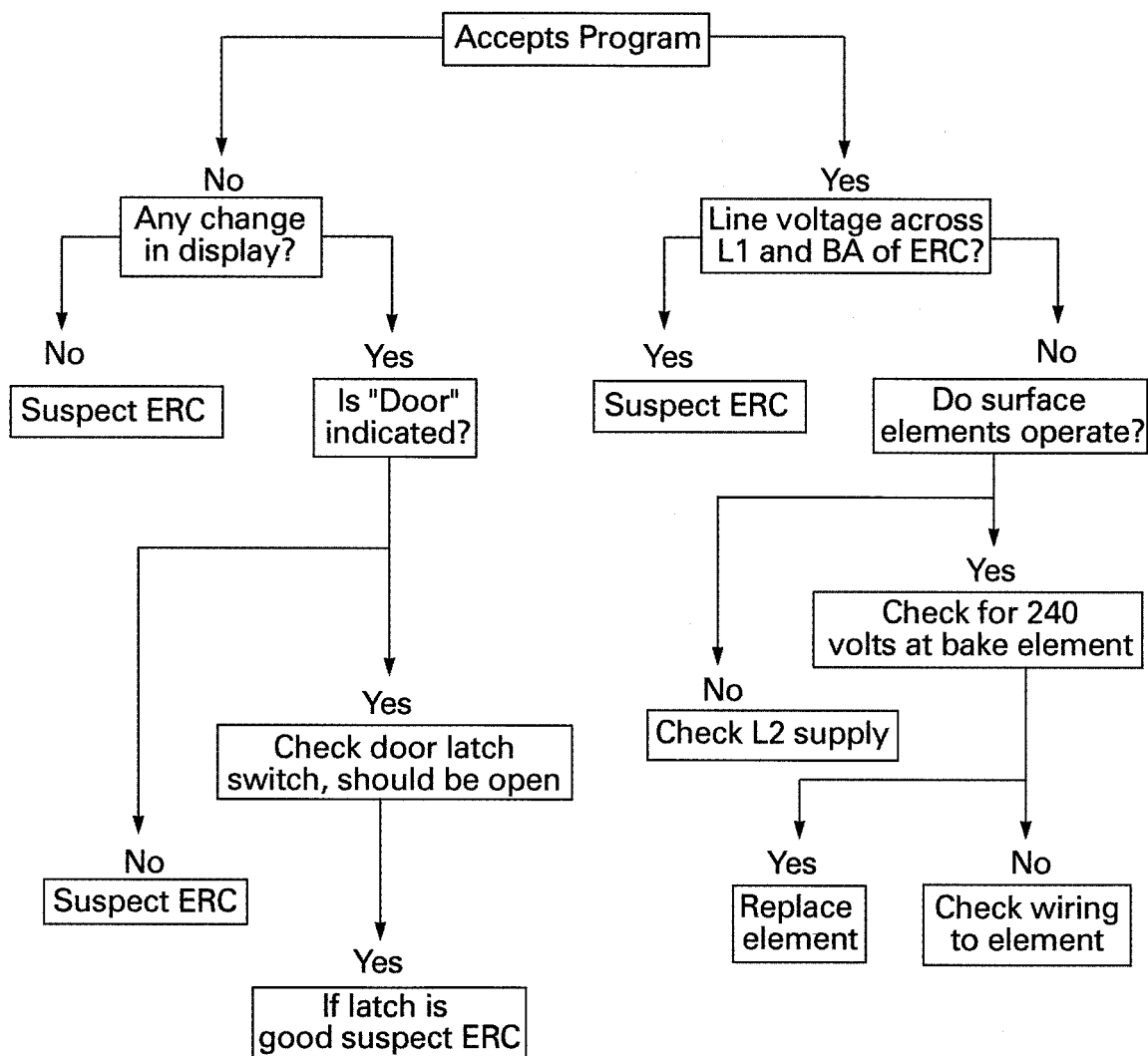

SC140TIF

Will not Broil

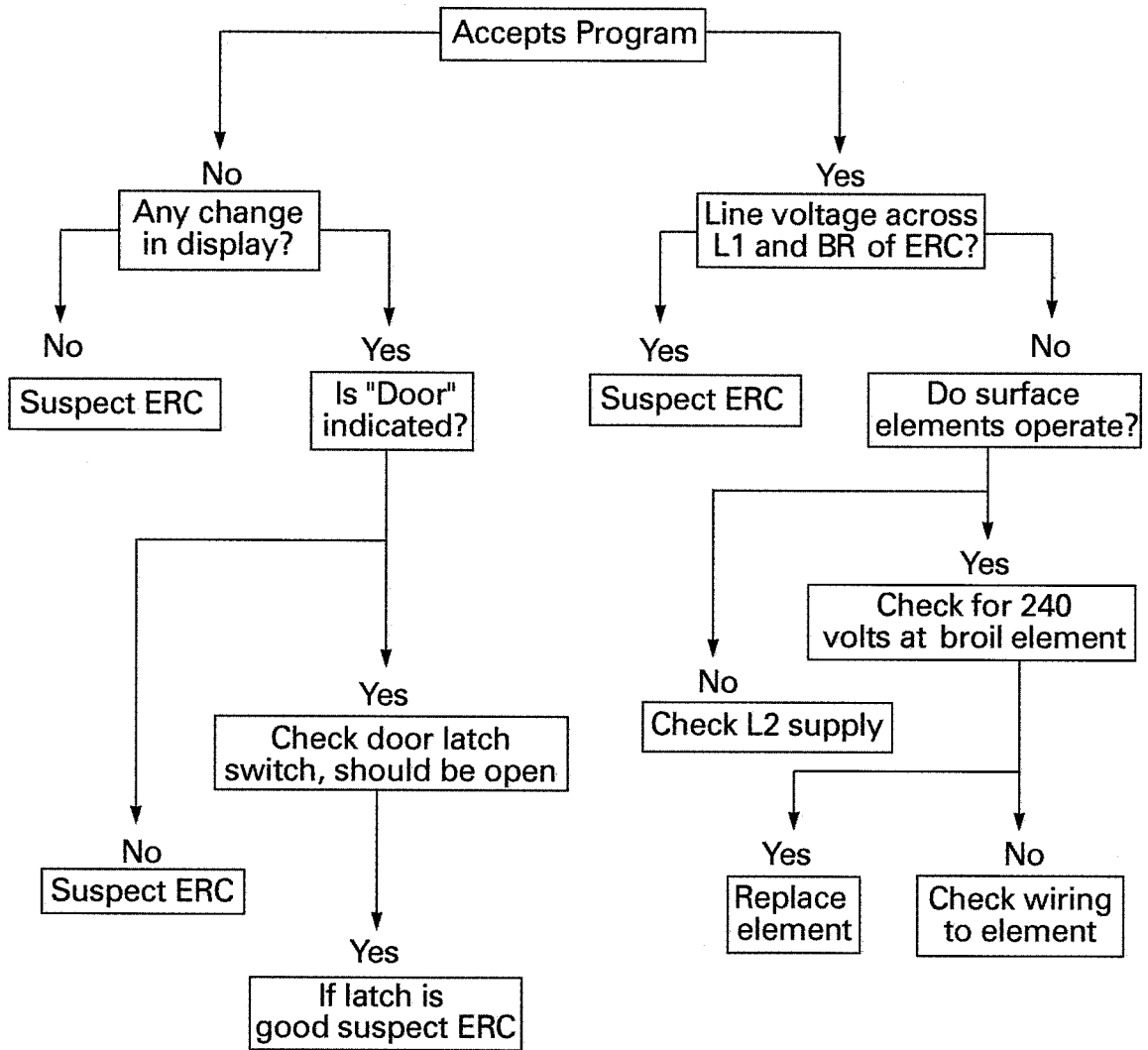

SC141TIF

Will not Self Clean

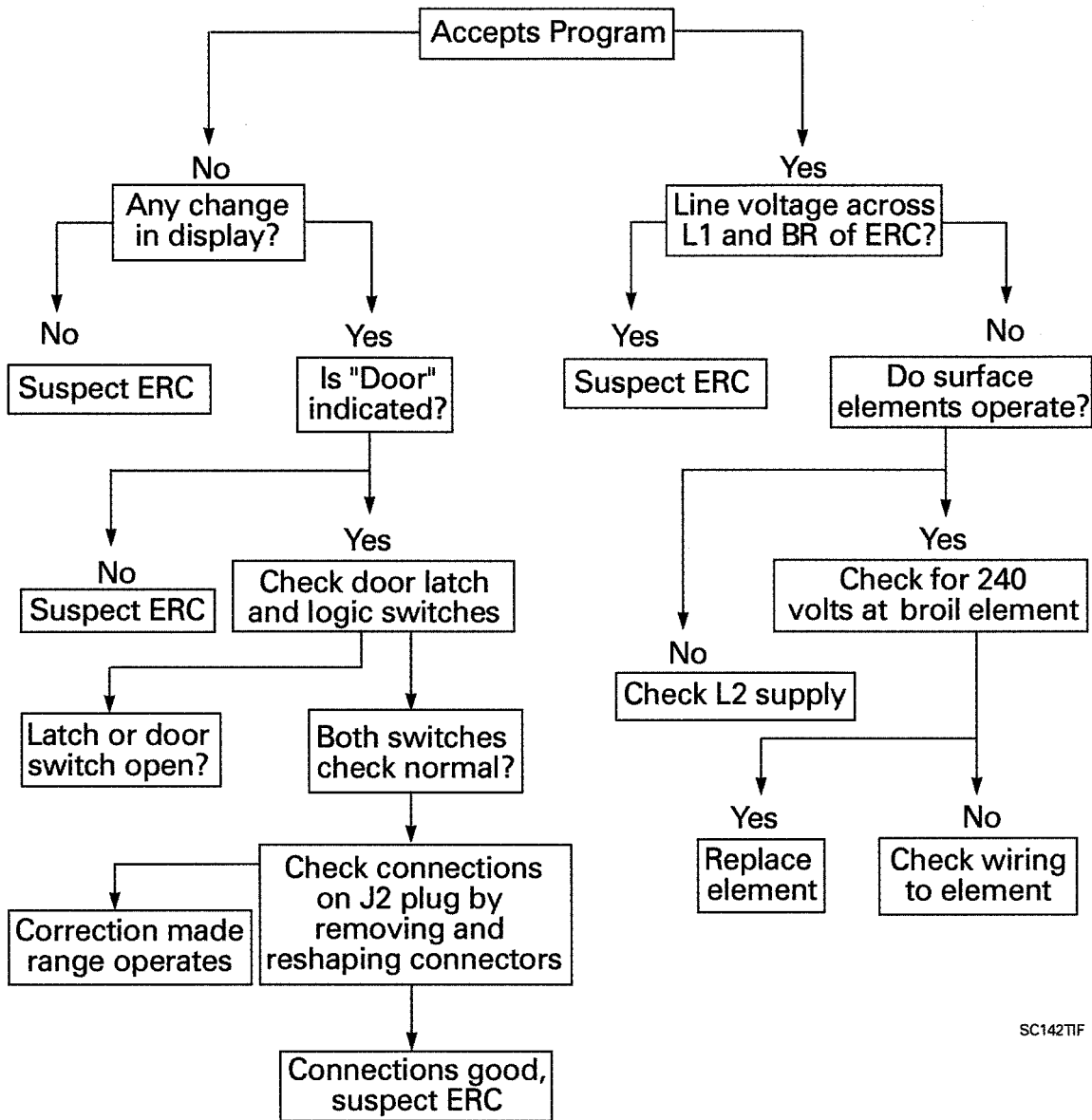

SC142TIF

T1 and T2 Electronic Oven Controls

Note:

Refer to photographs on pages 3-3 through 3-5 for control identification

These oven controls are self contained units that feature: touch key membrane, electronic control with self diagnosis, and relays to control outputs to the various features. Features of the range determine the number of relay outputs on the control assembly.

Membrane keypad:

Data is entered into the control via a membrane switch. This consists of an outer layer of polyester material that has a screen of decorative function pads on the front surface and a conductive material screen on the backside. The conductive creates 1/2 of the switch surface to choose an input into the control. The next layer of material is used as a spacer and contains an opening at each switch location, this open space assures the switch is open until force is applied to it. The second 1/2 of the switch contact is supplied by the conductive control chassis itself, it is made of metal and completes the ground path when mounted to the range chassis by screws. **Example: When the bake pad is pressed (13 to 28 ounces of pressure) the decorative panel on the control (containing the conductive material) is forced through the air gap created by the spacer layer. When the proper amount of force is applied the conductive material on the front layer will make contact with the conductive portion of the control chassis and the control will activate the bake cycle prompt in the display.**

Data input T1 control

The control accepts data via the function pad and the two slew keypads. There is an up and down slew key pad which is used to increase or decrease the desired inputs to the control. **The input rate for the slew pads are:** Clock, 1 minute for

each depression of the slew pad and 5 minutes if the pad is held down.

The input rate for a bake temperature input is 5° F for each depression of the slew pad and 10° F if the slew pad is held down.

Data input T2 control

The control accepts data via the function pads and the numeric keypads.

Bake, Electric Ranges for T1

The Bake function controls both the bake and broil units. During a Bake cycle the broil element will be on 6 seconds of a 60 second duty cycle the bake element will be on the remaining 54 seconds. The bake and broil elements will be staged, meaning that only one of the elements will be on at any one time. When a Bake cycle is chosen the control is preprogrammed to have a "jump in," or start up, temperature of 350° F which either of the skew keypads are pressed. The temperature can be adjusted from that point to any other desired temperature by using the "Up" or "Down" slew keys. The average center oven temperature will be 360° F at a 350° F setting, +/- 5° F. **Note: The control has a 12 hour energy saving feature that will terminate any heating cycle at the end of 12 hours. See instructions listed under 12 hour energy saving feature to disable this feature.**

Bake, Electric Ranges for T2

The Bake function controls both the bake and broil units. During a Bake cycle the broil element will be on 6 seconds of a 60 second duty cycle the bake element will be on the remaining 54 seconds. The bake and broil elements will be staged, meaning that only one of the elements will be on at any one time. When a Bake cycle is chosen the temperature must be entered by pressing the appropriate numeric pads. The average center oven temperature will be 360° F at a 350° F setting, +/- 5° F.

NOTE: The control has a 12 hour energy saving feature that will terminate any heating cycle at the end of 12 hours. See instructions listed under 12 hour energy saving function to disable this feature.

Bake, Gas Ranges for T1

The Bake function controls only the bake burner. During a cycle the bake burner will be on at a 100% rate until the set temperature is reached, then cycled on and off to maintain the set temperature. The cycle functions the same as the Electric Range regarding "jump in" temperature, the average center oven temperature, and the 12 hour energy saving feature.

Bake, Gas Ranges for T2

The Bake function controls only the bake burner. During a cycle the bake burner will be on at a 100% rate until the set temperature is reached, then cycled on and off to maintain the set temperature. The cycle functions the same as the Electric Range, both average the center oven temperature, and the 12 hour energy saving feature are identical.

Broil, Electric Ranges for T1

The Broil function controls only the broil element. The control has both "Hi" and "Lo" broil. After selecting the broil function "Hi" can be chosen by pressing the "UP" slew pad, the "Down" slew pad will give a "Lo" broil selection. "Hi" broil cycles the broil element at 100% on time until the temperature reaches 550° F, with a swing temperature of 30° F differential, between on and off cycles of the element. "Lo" broil cycles the broil element at an 80% rate, of a 60 second duty cycle and a maximum temperature swing of 30° F.

Broil, Gas Range for T1 & T2

The broil function controls only the broil burner. In both the "Hi" or "Lo" broil

cycles, the control will operate the broil burner at 100% rate. The only difference will be that the broil burner will be cycled at 450° F for "Lo" broil, and 550° F for "Hi" broil. The temperature swing or differential will be the same 30° F as the electric unit. *With the T2 Control, the "variable" broil feature operates the same as the electric unit.*

Broil, Variable, Electric Range for T2

The control has a variable broil feature. The Broil function controls only the broil element. After selecting the broil function "Hi" can be chosen by pressing the "Preset" pad. The "Preset" pad will also toggle the control between "Hi" and "Lo" broil, with "Lo" Broil maintaining a temperature of 450° F. "Hi" broil cycles the broil element at 100% on time until the temperature reaches 550° F, with a swing temperature of 15° F differential, between on and off cycles of the element. "Variable" broil cycles the broil element at an 80% rate, of a 60 second duty cycle, and a variable temperature of 300° F to 550° F with a temperature swing of 30° F. The temperature of the variable broil can be set in 1° F increments within the available set range of 300° F to 550° F. Switching from "variable" broil to "Hi" broil can be accomplished by entering 550° F with the numeric, digi-keypad. The display will then indicate "Hi" broil.

Convection Bake, Electric Ranges for T1

The Convection Bake function controls both the bake and broil heating elements and the convection fan motor. During a Bake cycle the broil element will be on for 6 seconds of a 60 second duty cycle, then the bake element will be on for the remaining 54 seconds. Both elements are staged, and will never be energized at the same time. When the set temperature is reached the cycle rate will continue to maintain the temperature. The convection fan will remain on continuous and not cycle the elements. The "jump in" temperature of

Convection Bake will be 325° F and adjustable from there via the slew keys. The convection fan icon in the display will also rotate in a clockwise manner during the cycle to indicate a convection cook mode is in operation.

Convection Bake, Electric Ranges for T2

The Convection Bake function controls both the bake and broil heating elements and the convection fan motor. During a Bake cycle the broil element will be on for 6 seconds of a 60 second duty cycle, then the bake element will be on for the remaining 54 seconds. Both elements are stage, and will never be energized at the same time. When the set temperature is reached the cycle will continue to maintain the temperature. The convection fan will remain on continuous and not cycle with the elements. By pressing the "Preset" key the "jump in" temperature of Convection Bake will be 325° F and adjustable from there via the digi-keys. The convection fan icon in the display will also rotate in a clockwise manner during the cycle to indicate a convection cook mode is in operation.

Convection Bake, Gas Ranges for T1

The Convection Bake Function Controls both the bake burner and the convection fan motor. The bake burner will be on 100% of the cycle until the set temperature is reached, at which time it will cycle off and on to maintain the set temperature. ***Note: The convection fan motor will be delayed for five minutes at the start of the cycle to allow the bake burner to reach efficient operating temperature. All other functions will operate identical to the Convection Bake, Electric.***

Convection, Dual Speed, Electric Slide in Ranges Only for T1 & T2

These units contain a 2 speed convection fan motor which are indicated by Convection Bake or Convection Roast. The cycle

rates of the bake and broil elements are the same 6 second for the broil element and 54 second for the bake element, during a 60 second duty cycle.

Drying, Slide-In Electric Ranges Models Only for T1

The broil element will be cycled on for 15 seconds, the bake element will be cycled on for 18 seconds, the remaining 27 seconds of the 60 second duty cycle will be "No Heat".

From either element. Pressing the Drying keypad will activate the Bake and Convection Fan icons in the display, pressing the Drying keypad a second time will enter a "jump in" temperature of 140° F. The allowable range of temperature is from 120° F to 160° F, which can be set by using the slew keys. The control will cycle the elements at the rate described above, and will maintain a temperature swing of 20° F or less from the set temperature.

Drying, Gas Slide-In Ranges for T1

The Drying feature will operate the same as outlined in the Convection, Dual Speed, Slide-In Electric Ranges ***with the exception of the 5 minute delay for the convection fan motor.***

Drying, Electric Ranges for T2

The Drying function controls both the bake and broil heating elements. The broil element will be cycled on for 15 seconds, the bake element will be cycled on for 18 seconds, the remaining 27 seconds of the 60 second duty cycle will be "No Heat" from either element. Pressing the Drying keypad will activate the Oven Cavity and Convection Fan icons in the display and set a "jump in" temperature of 129° F +/- 4° F. Pressing the Drying keypad a second time will enter a "jump in" temperature of 140° F. The allowable range of temperature is from 100° F to 200° F, which can be set by using

the digi-keys. The control will cycle the elements at the rate described above and will maintain a temperature swing for 20° F or less, from the set temperature.

Drying, Gas Ranges for T2

The Drying function operates the bake burner and the convection fan motor. The Gas Convection Drying cycle is accomplished through two stages. **Stage 1:** The bake burner is operated until the oven sensor reaches 107° F. The bake burner is cycled off for at least 30 seconds and does not cycle on until the sensor drops to 125° F. This allows the temperature rise of the oven cavity not to exceed an initial limit based on heat value of the bake burner.

Stage 2: The bake burner cycles on at 125° F and is cycled off at 129° F.

Note: The convection fan motor will be delayed for the first five minutes of the cycle to assure the bake burner has reached efficient operating temperature.

Clean, Electric Ranges for T1 & T2

The Clean function controls both the bake and broil heating elements. The broil element is on at a rate of 100% for the first 40 minutes of the cycle. If the oven temperature reaches 865° F before the 40 minutes is elapsed the broil element is deactivated. After the 40 minute time period the bake element will be on at a rate of 100% until the 865° F temperature is reached. Then the bake element is cycled to maintain 865° F temperature within a 20° F swing differential. The oven door lock system will be disabled, or unable to unlock, at a temperature above 400° F.

Clean, Gas Ranges for T1 & T2

The Clean function controls both the bake and broil burners. The cycle rate of the

broil and bake burner are the same as those shown for Clean, Electric Ranges. The time of the cycles and the temperature of the clean cycle are also identical.

Motorized Door Lock for T1 & T2

The control will energize the door lock motor for 4 seconds, at that point the contacts should close to indicate a locked condition of the door. The control will run the motor an additional 2 seconds to assure the lock motor cam has closed the switch. At that point the control will monitor the latch switch to assure the door is indicated as closed and locked. After a 6 second read time, the control will display "door" if the switch is not indicating closed and the motor will be energized again to "retry". If the control senses that the lock switch is closed properly the display will indicate "Lock", and the clean cycle can be completed.

At the end of the clean cycle and the oven temperature is below 400° F the control will energize the lock motor relay for half a revolution of the lock mechanism, plus 0.5 seconds. This will assure the lock switch is closed, indicating the door is released and ready for opening.

Ranges with Manual Door Lock T1 & T2

The door lock lever must be manually closed, at that time, the control will read the lock switch in a closed condition and allow the clean cycle to begin. The control will activate the "Lock" indicator in the display when the temperature of the oven reaches 400° F and disables the latch from being opened until the oven temperature is below 400° F Field Test Mode for T1 & T2.

The control can be placed in a test mode to display the actual oven sensor temperature by completing the following procedure: Press Bake, slew down to 100° F, hold down the bake key for 3 seconds. The control will flash the Preheat indicator and display the sensor temperature until the cancel key is pressed. At this time the display will also indicate the last recorded

fault code, which is stored in the control. The fault code will be displayed by indicating an "F" followed by two numerals, the first number is the main fault code sensed, the second number refers to a "sub fault" which is listed in the following chart. Example: F14, which indicates an over temperature sensed in a cooking mode {I.E.. 650° F}.

Code	Sub Code	Description	When Read by Control	Read Time
F1	1	Oven temp while cooking	Latch, unlocked position	6 seconds
	2	Oven temp while cleaning	Latch, locked position	6 seconds
	3	Shorted key	Always	45 seconds
	4	Keyboard disconnected	Always	30 seconds
	5	Cancel key out of spec..	Always	30 seconds
	6	Relay activated	Time of day mode	30 seconds
	7	Slave micro not sensed	Always	30 seconds
	8	Option or sensor input failure	Always	30 seconds
	9	Eeprom error/control not calibrated	EEPROM/micro reading	0 seconds
F3	1	Sensor/circuit failure	Cooking or clean cycle	6 seconds
F9	1	Door will not lock	Door lock motor energized and latch switch not closed	6 seconds
	2	Door will not unlock	Door lock motor energized and latch switch open	30 seconds
	3	Door lock inputs to the control indicate the switch is both closed and open	Always	0 seconds

Fault Codes for T1 & T2:

F1: Indicates an error in the control circuitry. It is always active in a non-cook mode. This means if the control sees an output to a relay or heating function when in time or day mode it will shut the system down to a safe condition. Also monitors an over temperature condition for a chosen heating function. Example: Over 550° F in a bake mode. Check oven sensor for correct ohm value or for charred connector, **if sensor is OK**, replace the control.

F3: Open or shorted sensor. Test sensor for proper ohm value, frayed or pinched wiring, or connector damage. Replace as necessary. See chart for sensor resistance values.

F9: Door lock circuitry fault sensed. This fault code appears if the control is unable to recognize the opening and closing of the door lock switches at the proper times. The control is looking for a signal back from the door lock system circuitry to assure the door is in the proper position for the function chosen. Check the door lock switch, wiring, and lock assembly, adjust or replace as needed. **If lock system and wiring is OK, replace control.**

Oven Temperature Adjustment for T1

Press the Bake Key and slew the temperature up to 550° F. Press the bake key again and hold for 3 seconds. The Bake key must be pressed within 30 seconds of the first input. The temperature offset is displayed and can be adjusted for -35° F to +35° F. Use the slew keypads to adjust the temperature offset. If any key other than the slew pads are used the control will return to time of day display.

Oven Temperature Adjustment for T2

Press the Bake key and entering 550° F with the digi-keys. Press the bake key again and hold for 3 seconds. The Bake key must be pressed within 30 seconds of the first input. The temperature offset is displayed and can be adjusted from - 35° F to +35° F. Use the digi-key pads to adjust the temperature offset, the temperature offset can be increased or decreased in 5° F increments. If any key other than the digi-key pads are used the control will return to time of day display. All bake functions will be re-calibrated to the offset temperature selected. The Clean temperature will be modified by -3° F if any nonzero offset is entered.

Demo Mode for T2

The control can be locked out by pressing and holding the Bake and Cancel keypads down at the same time for 3 seconds. An audible tone will sound to signal the demo mode started. The Bake, Convect, and the 325° F icons will then be displayed without energizing the heating elements or con-

vect fan motor. The Demo mode will be terminated when any key is pressed.

Control Lockout for T1

The control can be locked out by pressing and holding both the Stop time and Cancel keypads in for 3 seconds. "OFF" will be displayed indicating the keyboard has been disabled. The lockout feature can be canceled by pressing the same keypads for 3 seconds.

Control Lockout for T2

The control can be locked out by pressing and holding both the Stop time and Cancel keypads in for 5 seconds. "Lock" will be displayed indicating the keyboard has been disabled. The lockout feature can be canceled by pressing the same keypads for 5 seconds.

Twelve Hour Energy Saving Mode Cancellation for T1

There is a set 12 hour limit for cooking functions preset into the control. To eliminate the 12 hour limit; press and hold the clock key down for 3 seconds, then use either slew key to change the display until it shows 8:88. To restore the 12 hour cooking limit repeat the steps until the display shows 12:00. The selection will be made when the cancel key is pressed or the 30 second time out elapses.

Twelve Hour Energy Saving Mode Cancellation for T2

There is a set 12 hour limit for cooking functions preset into the control. To

To eliminate the 12 hour limit; press and hold the clock key down for 3 seconds, then use any key to change the display until it shows 88:88. "Time" will flash in the display while this feature is being programmed. To restore the 12 hour cooking limit repeat the above steps and press the number "1" key once until the display shows 12:00, the selection will be made 4 seconds after the last key entry.

Clock Display Disable for T1 & T2

The clock display can be disabled if the consumer wishes a blank display when the range is not in use. To disable the clock display press and hold both the Cancel and Clock keypads for 3 seconds. The time of day can be viewed by pressing the clock pad, it will display the time for 4 seconds then go blank again. If while in the blanked mode, any timed functions chosen will cause the time to flash, indicating the display needs to be activated. To reactivate the time of day display follow the same procedure for disabling.

End of Timer Reminder Options for T2

The control has three selectable options for the end of timer signal beeps. The selections are:

1. One four second beep followed by one 0.67 second beep every 30 seconds for a period of 5 minutes or until cancelled.
2. One four second beep followed by one 0.67 second beep every minute for 12 hours or until cancelled.
3. One four second beep.

To change the end of timer reminder press the Cancel and timer keys for 3 seconds. The control will give a single beep and display the current option selected, for example, "1" and "Timer" will be displayed.

To change the end of timer reminder press the Cancel and Timer keys for 3 seconds. The control will give a single beep and display the current option selected, for example, "1" and "Timer" will be displayed in the timer if option "1" is selected. The user has 30 seconds to select an option by pressing the appropriate key, for example keypad "2" will select option 2. Four seconds after the selection has been made the display will return to the time of day. The timer can not be active **during the option change.**

Oven Temperature Sensor Value Chart for T1 Controls			
Degrees F	Resistance	Degrees F	Resistance
100	1143 ohms	500	1949 ohms
200	1350	600	2142
300	1553	700	2331
350	1654	800	2516
400	1753	900	2697
		1000	2874

*Sensor Type: RTD 1000 ohm Platinum
Calibration: 1654 ohms @ 350° F
1050 - 1100 ohms @ ambient*

50/60Hz Operation: The control part numbers used are cycle specific and must be matched to the model numbers approved for 50 or 60 Hz installations.

Oven Temperature Sensor Value Chart for T2 Controls			
Degrees F	Resistance	Degrees F	Resistance
100	1143 ohms	500	1949 ohms
200	1350	600	2142
300	1553	700	2331
350	1654	800	2516
400	1753	900	2697
		1000	2874

*Sensor Type: RTD 1000 ohm Platinum
Calibration: 1654 ohms @ 350° F
1050 - 1100 ohms @ ambient*

50/60Hz Operation: The control will automatically sense the supply voltage frequency and adjust accordingly.

RS1 Electronic Oven Control

Control Features

Slew entry, time of day clock, bake, broil, clean, timer, touch keys, control lockout, clock disable, timed bake, delayed time bake/clean, 12 hour energy saving mode, 50/60 Hz operating frequency.

Slew Entry

There are 2 slew keypads, one to increase, the other to decrease data input. Data entry for the clock is at a rate of "1" minute for each depression and "5" minutes if the slew key is held down. Data entry for Bake temperature is at a rate of 10° F for each depression or in 10° F increments if slew keypad is held down.

Bake Cycle, Electric Ranges

The bake function controls both the bake and broil heating elements, but the elements are never on at the same time {staged bake}. During a bake cycle there is a 60 second duty cycle, the broil element will be on for 6 seconds and the bake unit will be on for the remaining 54 seconds. Both elements will continue to cycle at this rate for both preheat and to maintain the set temperature for the remainder of the bake cycle. The control will accept bake temperature entries between 170° F and 550° F. An offset is built in to the control to give an average center oven temperature of 360° F at a 350° F setting.

NOTE: If no change is made to the control after a bake cycle (or any heating cycle other than clean) is started, the control will abort the heating cycle after 12 hours. To disable this energy saving feature, see instructions listed under 12 hour energy saving mode.

Bake Cycle, Gas Range

The Bake cycle controls the bake burner. During the bake cycle the bake burner will be on 100% until the set temperature is reached, then cycled on and off to maintain the set temperature. An offset is built in to the control to give an average center oven temperature of 360° F at a 350° F setting.

NOTE: Has 12 hour energy saving feature. See instructions to disable, listed under 12 hour energy saving feature.

Broil Cycle, Electric Ranges

To operate the Broil cycle, press Broil keypad, the "up" slew pad will select "Hi" broil, the "down" slew pad will select "Lo" broil. The "Hi" broil function operates the broil element at 100% power and will cycle the element off at 550° F. The cycle rate will maintain the 550° F temperature within a 30° F swing between cycle off and on. The "Lo" broil function operates the broil element at an 80% rate, based on a 60 second duty cycle, to maintain an average 450° F center oven temperature. The control will then cycle the broil element at the 80% rate to maintain the 450° F temperature, with a 30° F swing between cycle off and on.

Broil Cycle, Gas Ranges

The broil cycle operates the broil burner. The selection of "Hi" or "Lo" broil, and the temperature maintained in the oven is the same as the Electric Ranges with the following exceptions. In "Lo" broil the broil burner is on 100% during the rise to 450° F, and cycled at 100% to maintain the temperature.

Oven Temperature Adjustment

Press the Bake key and slew the temperature up to 550° F. Press the bake key again and hold for 3 seconds. The Bake key must be pressed within 30 seconds of the first input. The temperature offset is displayed and can be adjusted from -35° F to +35° F. Use the slew keypads to adjust the temperature offset. If any key other than the slew pads are used the control will return to time of day display.

Twelve Hour Energy Saving Mode

There is a set 12 hour limit for cooking functions preset into the control. To eliminate the 12 hour limit; press and hold the clock key down for 3 seconds, then use either slew key to change the display until it shows 8:88. To restore the 12 hour cooking limit repeat the steps until the display shows 12:00. The selection will be made when the cancel key is pressed or the 30 second time out elapses.

50/60Hz Operating Frequency

The control will monitor the frequency supplied to it and automatically adjust.

Keypad Entry

The keypads activate a mechanical switch mounted to the face of the control and have an activation force of 12 to 28 ounces of pressure needed to close the selected switch. The membrane is basically a decorative overlay which indicates the location of available functions.

Degrees F	Resistance	Degrees F	Resistance
100	1143 ohms	500	1949 ohms
200	1350	600	2142
300	1553	700	2331
350	1654	800	2516
400	1753	900	2697
		1000	2874

*Sensor Type: RTD 1000 ohm Platinum
Calibration: 1654 ohms @ 350° F
1050 - 1100 ohms @ ambient*

Note:
Refer to photographs on pages 3-3 through 3-5 for control identification

2. General Component Access

Electrical Safety

The following instructions are based on safety considerations and must be strictly followed to eliminate the potential risks of fire, electrical shock, or personal injury.

Whenever the appliance is being serviced, the electrical supply must be disconnected to avoid contact with live terminals. The circuit breakers should be switched to the OFF position or the fuses removed from the branch electrical supply circuit. Prior to initial service, an electrical check (voltage check) for the absence of power (voltage) at the appliance should be done, either at the main terminal block or available electrical supply inlet on the unit to insure that the correct circuit breakers have been thrown or the correct fuses removed and no power (voltage) is present at the appliance.

If electricity is required for a test to check for power or wattage at a component, the electricity should be turned off, the necessary connections or adjustments made and then the electricity restored for the test. As soon as the test is completed, the appliance should be disconnected from power before the electrical connections are removed or further service is performed.

- Disconnect the appliance from power before making or breaking electrical connections or adjustments.
- Disconnect the appliance from power before replacing components or performing service.

Service Procedure

When testing, removing or replacing component(s) or performing service:

1. **Disconnect the appliance from power.**
2. Note the location of electrical wiring attachments and the order of disassembly for ease in reassembly.
3. Reassemble in the reverse order of removal unless specified otherwise.
4. Be sure that electrical connections are attached and secure.
5. Be sure that wiring is secured away from sharp edges and moving parts.
6. Do not bypass or disconnect any part or device designed into the appliance.
7. Be sure that ground wiring is connected and secure.
8. Be sure that access panels and covers are installed.

Electrical Supply

An adequate electrical supply system is required for the cooking appliance. All wire connections must be in accordance with local codes and be properly insulated. Check with local utility for governing electrical codes and ordinances. In the absence of local electrical codes, the National Electrical Code, NFPA No. 70, governing electrical range installations must be followed.

A copy of the National Electrical Code, NFPA No. 70, can be obtained by writing to:

NATIONAL FIRE PROTECTION
ASSOCIATION
Batterymarch Park
Quincy, Massachusetts 02269

Most local Building Regulations and Codes require that all electrical wiring be done by licensed electricians. All wiring should conform to Local and National Electrical Codes. Units require a single phase three wire 120/240 volt or 120/208 volt, 60 Hz, AC circuit. Wiring codes require that a separate circuit be run from the main entrance panel to the range and that it be equipped with separate disconnect switch and fuses, either in the main entrance panel or in a separate switch and fuse box. In some communities, a solid or flexible continuous armored conduit must be used from main entrance panel to the terminal box on the rear of the range. Others will permit the termination of the range circuit at a polarized three or four wire plug-in outlet placed at a convenient point near the back of the range. The range is then connected to this outlet through an approved range connector (pigtail) fastened securely to the terminal block with proper relief at the range and a three or four pronged plug at the opposite end.

Outside Wiring

The local utility company will tell you whether the present electric service to the home is adequate. It may be necessary to increase the size of the wiring to the house and service switch to take care of the electrical load demanded by the range. The kilowatt rating for the range is specified on the name plate on the range.

House Wiring

Most local Building Regulations and Codes require that all electrical wiring be done by licensed electricians. All wiring should conform to Local and Canadian Electrical Codes. Ranges require a single phase four wire 120/240 volt 60 Hz, AC circuit. Wiring codes require a separate circuit be run from the main entrance panel to the range and that it be equipped with separate disconnect switch and fuses, either in the main entrance panel or in a separate switch and fuse box.



General Component Placement

Below is a general guide illustrating the placement of most components on the electric range.

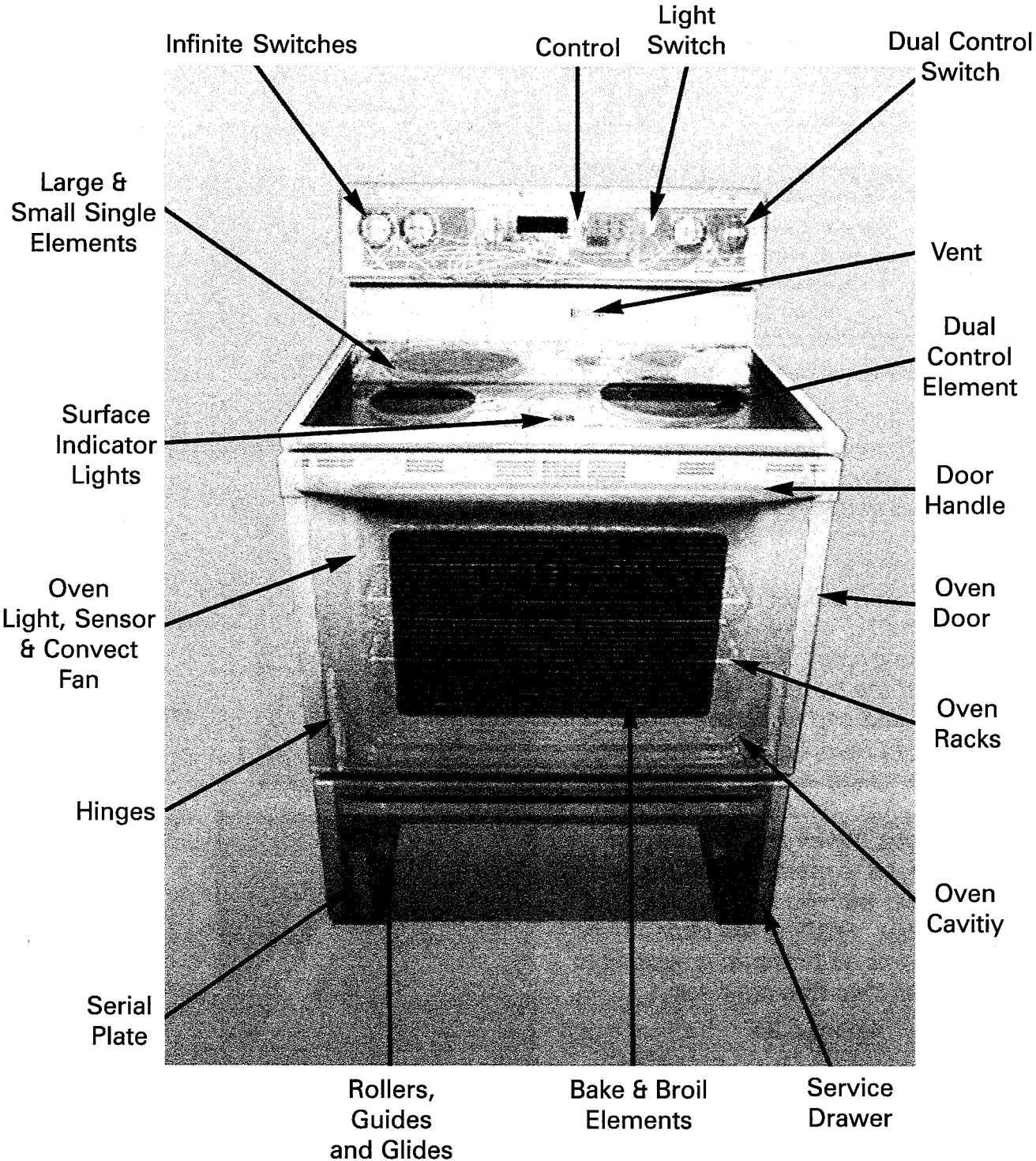

Oven Door Removal

Open the door to the broil position. Grasp the door at the top upper third, with both hands. Lift upward on the door, removing it from the hinges. After removal place the door in safe area. It is recommended that the door be laid flat on a protected surface to avoid damage.

⚠ ATTENTION SERVICER

The following instructions may help in the case of a inoperable door latch or "no power" situation.

⚠ WARNING



Always disconnect electrical power to the appliance before beginning service or repair procedures.

Door Locked (Inoperable Latch)

Note: Occasionally the oven door will be closed in a locked position and the door latch will not open. A tool can be constructed from a clothes hanger. This tool has been very useful in alleviating the locked door problem. Use a clothes hanger (or similar gauge wire) that has been straightened, using wire-cutters and pliers to make a small "U" shaped hook on one end of the hanger. Hold the straightened end and insert the end with the "U" shaped hook between the front closure of the range and the locked door from the left side. Gently "feel" for the door latch hook. When the "U" shaped hook is engaged, a medium pull pressure should pull the latch hook to the left and unlock the door. Pushing the door inward at the same time as pressure is applied to latch hook will help free the door.

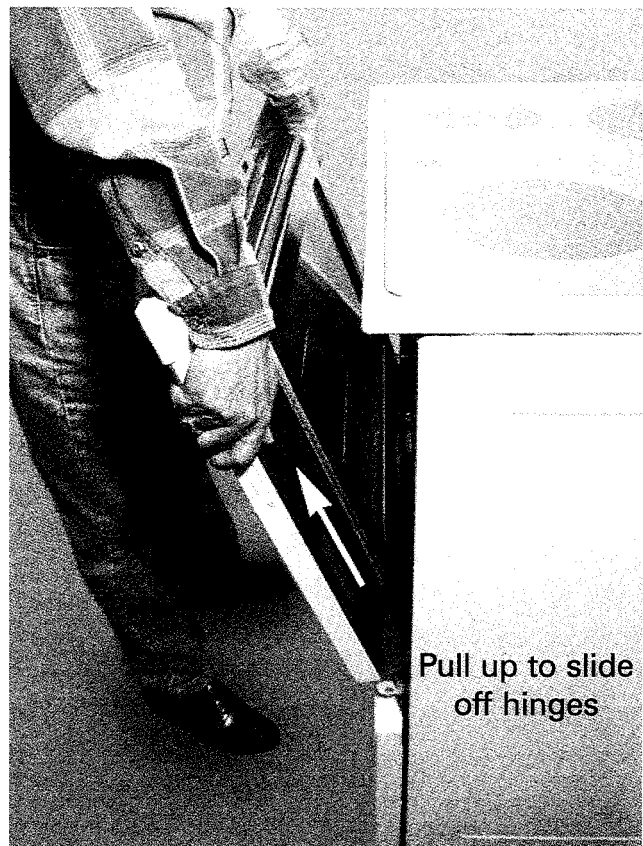
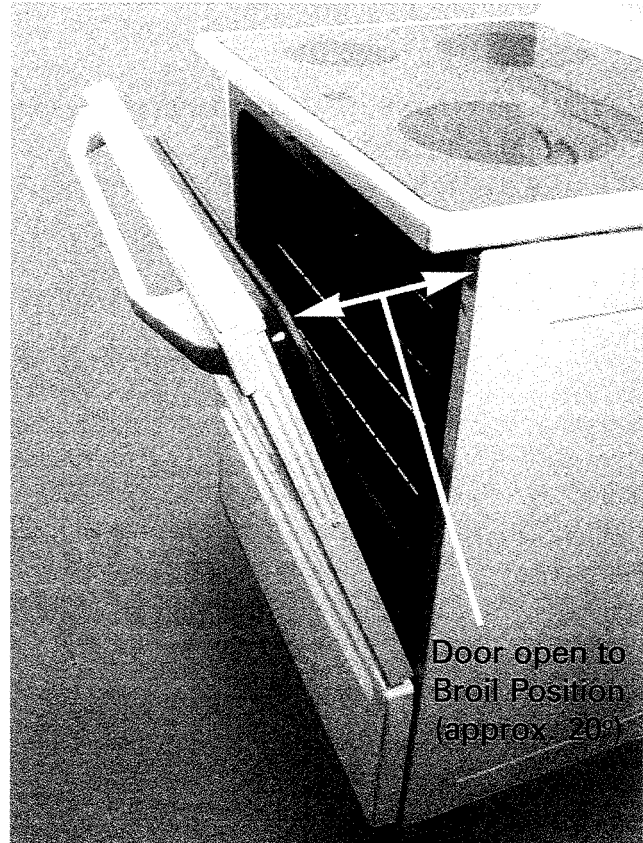
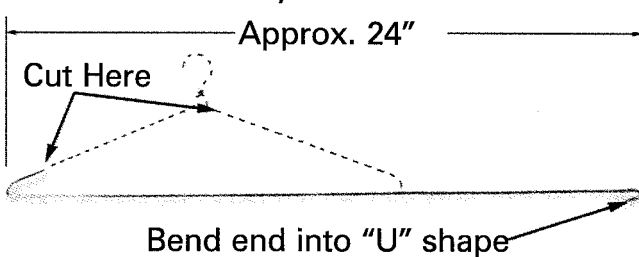

Door and Base Drawer Assembly Breakdown

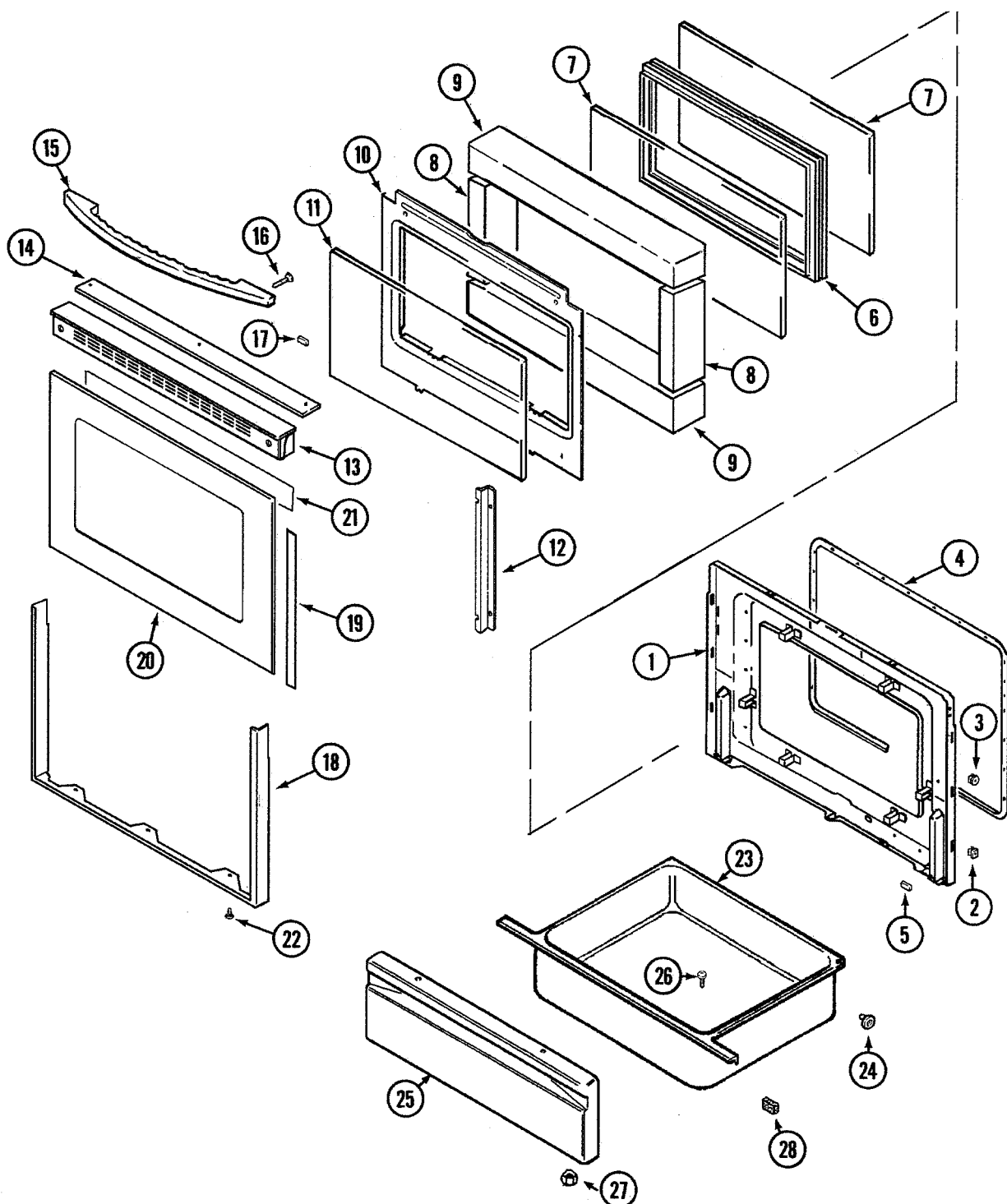

- | | | | | |
|-------------------|--------------------------|-----------------------|--------------------------------|---------------------|
| 1. Lining, Door | 7. Glass, Inner | 13. Trim, Top | 19. Tape, Foil | 23. Drawer, Storage |
| 2. Nut, Snap | 8. Insulation, Side | 14. Insert, Door Trim | 20. Glass, Door | 24. Roller, Drawer |
| 3. Nut, Snap | 9. Insulation, Oven Door | 15. Handle, Door | 21. Tape, Foil
(8.75" x 1") | 25. Panel, Drawer |
| 4. Gasket, Door | 10. Baffel, Door | 16. Screw, Handle | 22. Screw, Frame
(Bottom) | 26. Screw, Panel |
| 5. Spacer, Rubber | 11. Glass, Screened | 17. Tape, Dbl. Sided | 27. Nut, Lock | 28. Spacer, Rubber |
| 6. Frame, Glass | 12. Retainer, Glass | 18. Frame, Door | | |

Removing Top Assembly (Electric)



Disconnect appliance from power source. Open oven door and remove two 1/4" hex head screws that secure the top to a flange located just above the oven door. Screws are located at the front corners of the top .

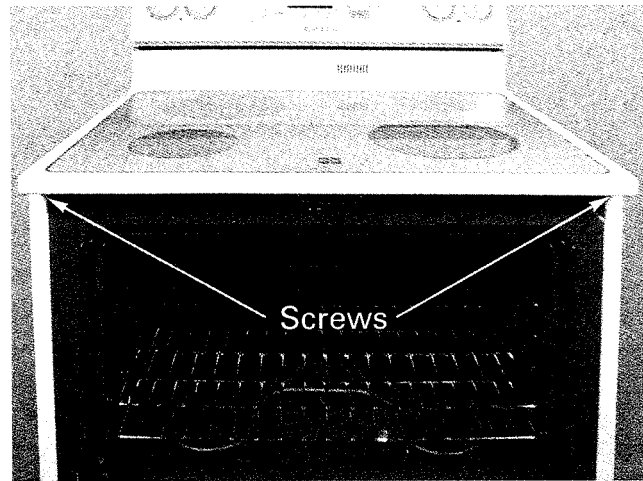

NOTE: There are no hinges holding the top in place. Once the screws are removed and the connector is disconnected, the top is loose and can be lifted off.

After the screws have been removed, grasp the top with both hands firmly, and pull the range top forward. Disconnect the multi-pin wiring harness connector. Lift top upward and remove.

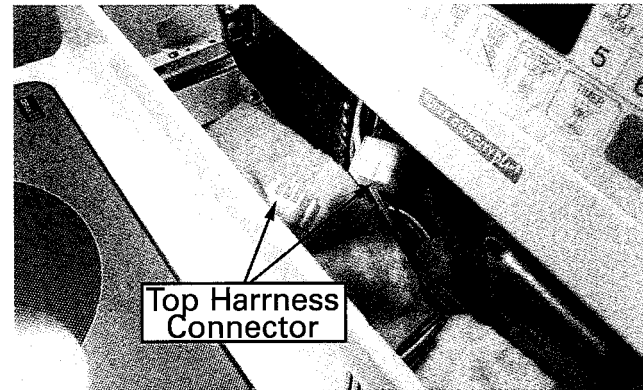

NOTE: If service to the elements is necessary, place the top on a towel or other protective covering to prevent any damage to the top or the range.

After the top is removed, you now have access to the door latch assembly, door lock switches hot surface indicator lights, and elements.

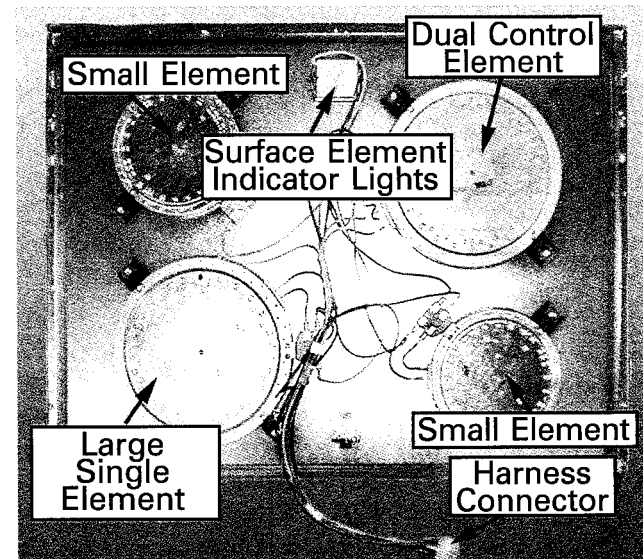

Removing Top Assembly (Gas)



Sealed Burner Wrench

To remove the gas range top, the sealed burners must first be disengaged from the top. If the burners are left in place, the burner tubes and orifice fittings will be damaged when lifting the top. To make this job easier, a service tool is available. The Sealed Burner Wrench can be ordered from a Maytag parts dealer.

P/N 8312D075-60. It is strongly recommended this tool be used to release the burners from the top. Other methods will usually result in damage to the burner and/or igniter. The burner wrench is designed with a "gap" that accommodates the igniter and does not allow pressure to be placed on the ceramic insulator. If the igniter is broken the burner assembly must be replaced.

Burner Wrench Placement

The burner wrench must be placed on the sealed burner assembly properly to avoid damage to the burner. The wrench is boldly labeled to indicate how to use the tool. A sticker on the inside band of the wrench is marked "Align Ignitor Here", this is the area in which the igniter fits between the clamping surfaces of the wrench to avoid pressure that may damage the insulator.

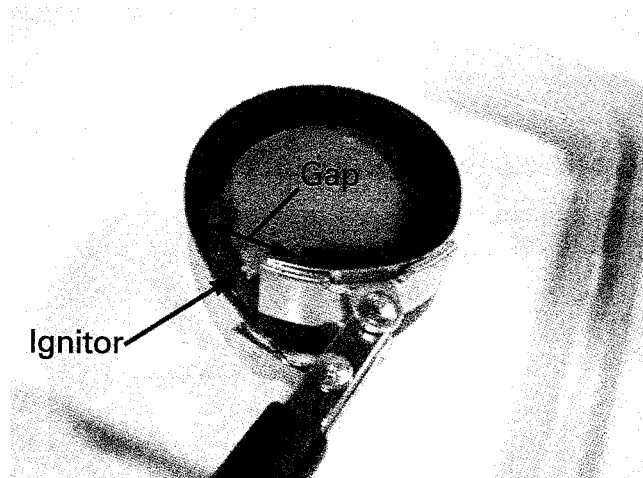

Sealed burner Removal

After the the wrench has been properly aligned on the burner, steady even counter clockwise rotation will release the burner. It should only be necessary to turn the burner approximately an 1-1/2" to loosen it. Some minor "crunching" or "grinding" sounds will be heard. This is normal, however, care should be used to avoid chipping the finish in visible areas.

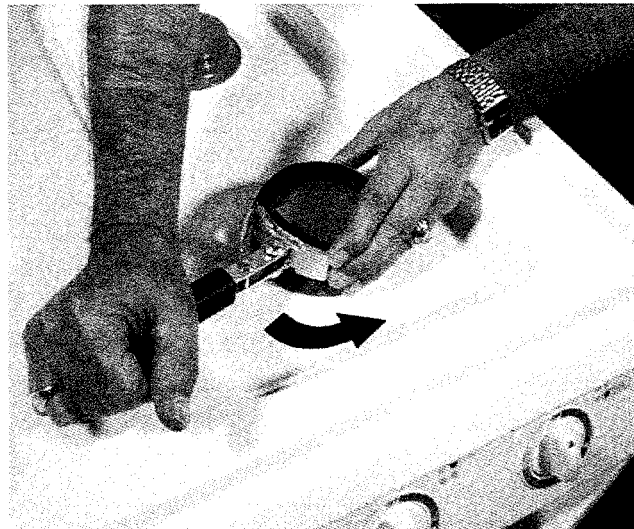

Lift the burner straight up and out of the mounting hole.

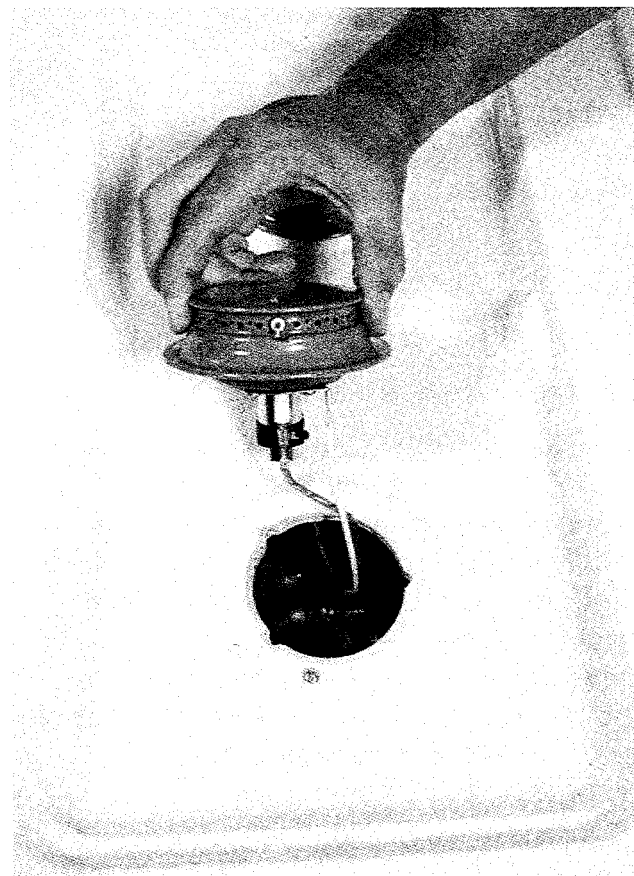

Removing the Top (Gas)

Once the burner(s) have been removed from the top, using needle nose pliers, disconnect the igniter wiring. It's a good idea to mark these wires to remind you where to reconnect them when reassembling. Place the burners in a safe place to avoid chipping or dropping. Inspect all parts of the burners before reinstalling.

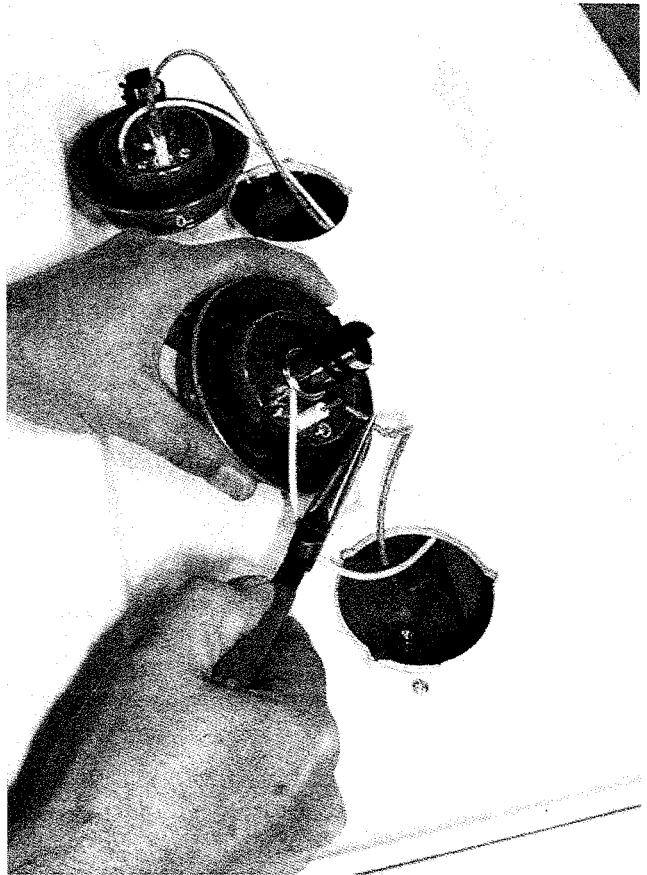

After the burners have been removed, remove one screw and washer from each of the four burner openings. These screws secure the burner supports to the top.

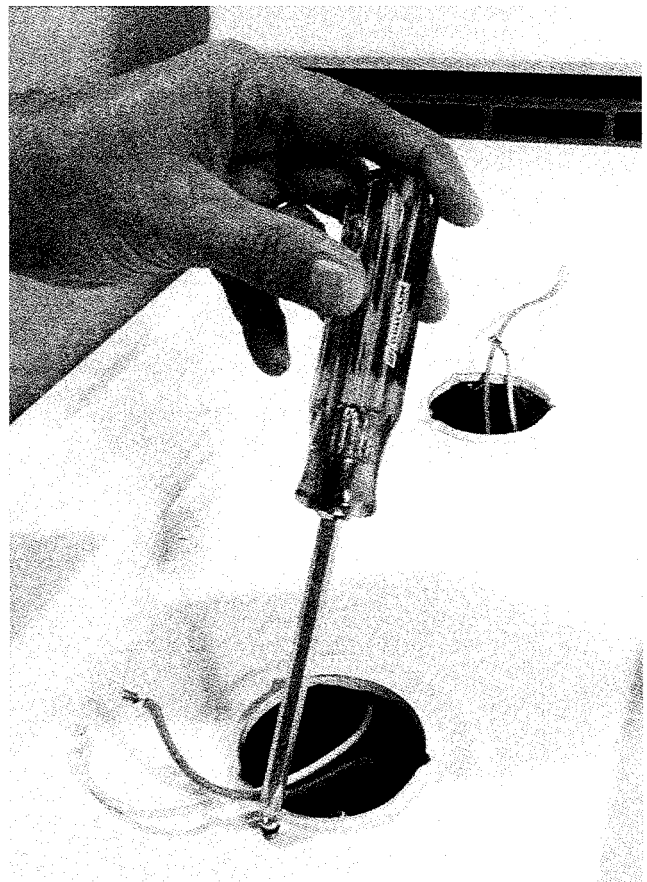

Top Clips (Gas)

Using a flat knife (putty knife) or the like, find the top clip on either side of the manifold panel. Place the knife between the top of the manifold panel and the bottom edge of the top. Locate the clip at approximately 4-1/2" in from either side of the range. Push the clip inward while applying upward pressure to the corner of the top. The top should "pop" free. Repeat this procedure for the other side. At this point the top should be loose and ready to be removed. Lay the top flat on a protected surface out of the way.

⚠ ATTENTION SERVICER

When tightening fasteners against porcelain coated surfaces, use caution to avoid over tightening. If fastener is over tightened or not properly aligned, porcelain will chip, crack or flake.

The components shown below can now be repaired or removed.

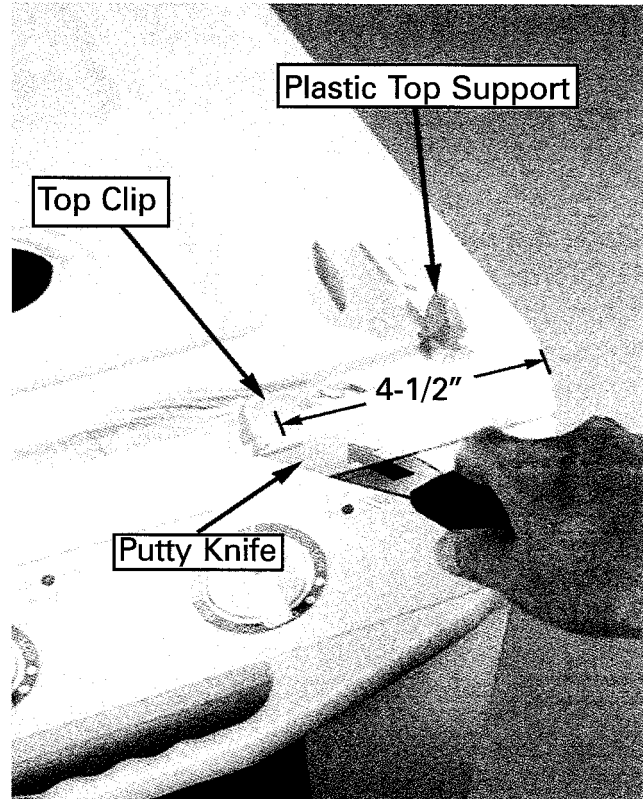

This view shows the clip and top support as if you can see through the top.

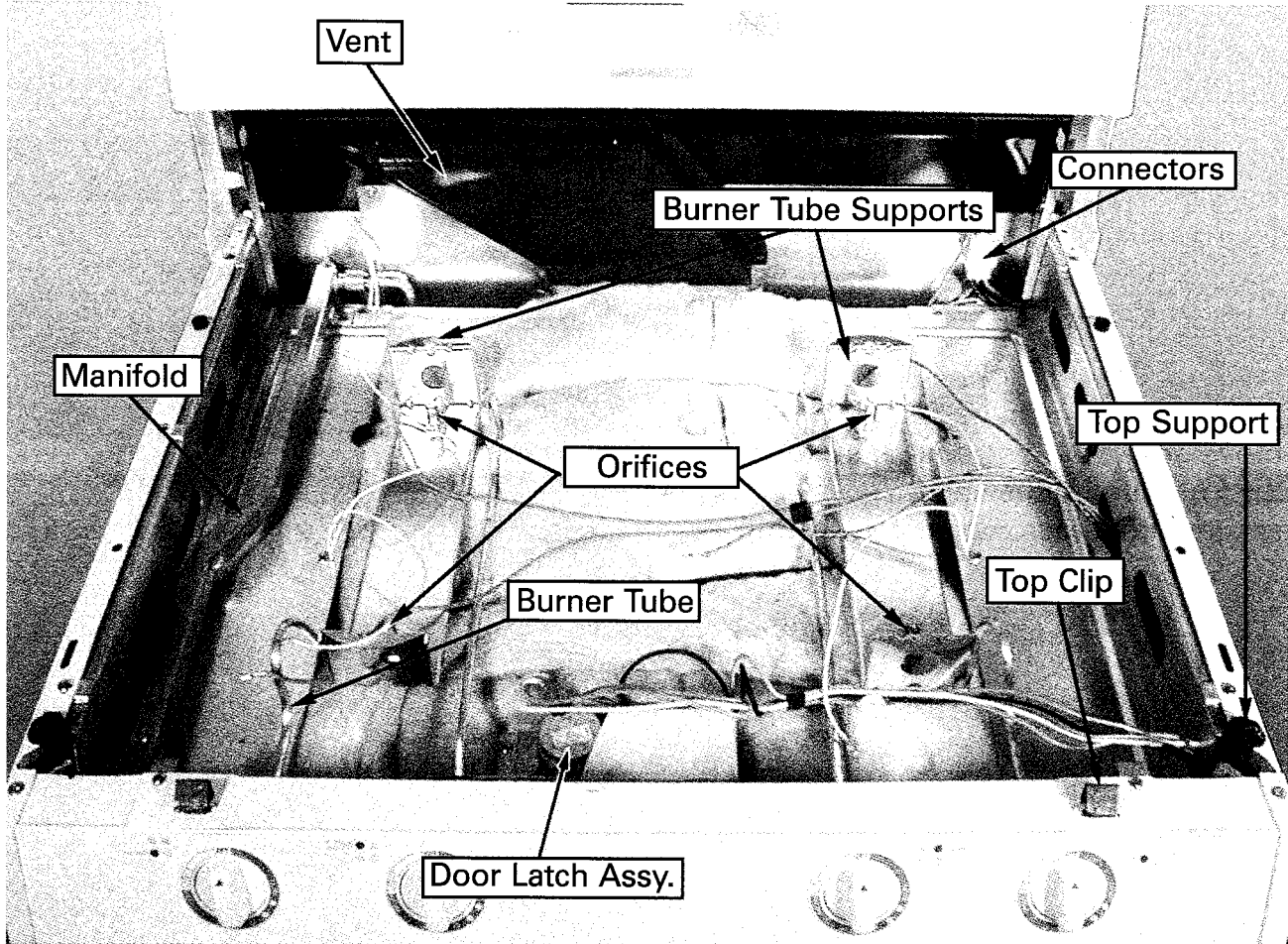

Removing Door Latch Assembly (Electric & Gas)

⚠ ATTENTION SERVICER

When making repairs in the area of the oven vent, be sure that the insulation is replaced in its original position to avoid possible over heating during a clean cycle.

After the top has been removed, you have easy access to the door latch assembly and door lock switches.

To remove the door latch assembly, first remove two 1/4" Phillips head screws and rubber washers from the upper front closure on either side of the latch hook.

Two additional screws can now be removed to free the latch assembly from the mounting plate.

Note: To reassemble - reinstall the front screws and washers then fasten the mounting plate that holds the door latch assembly in place. Check to be sure that insulation is not protruding through the door latch slot.

⚠ ATTENTION SERVICER

When tightening fasteners against porcelain coated surfaces, use caution to avoid over tightening. If fastener is over tightened or not properly aligned, porcelain will chip, crack or flake.

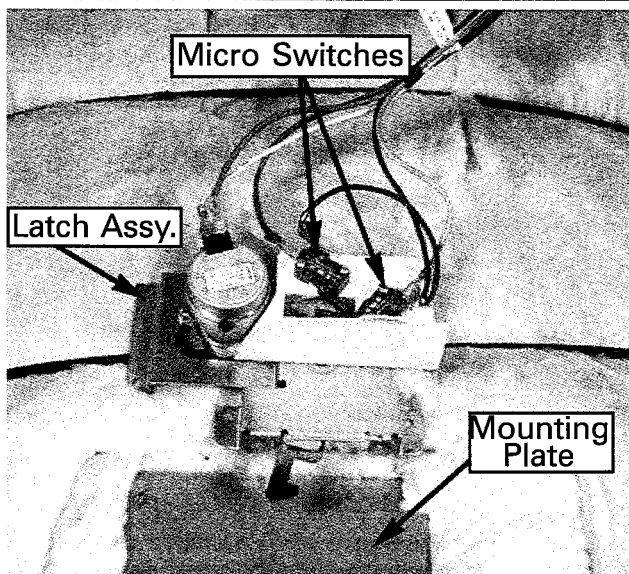
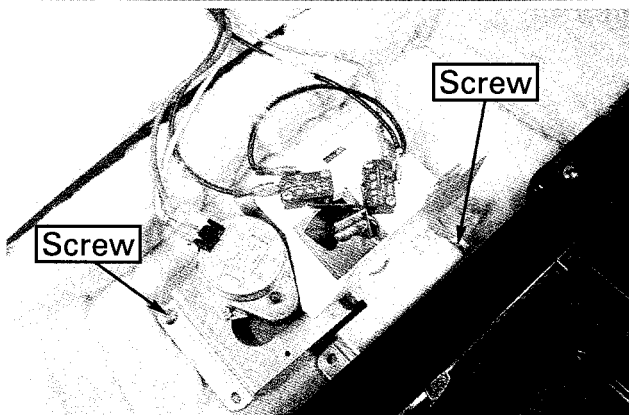
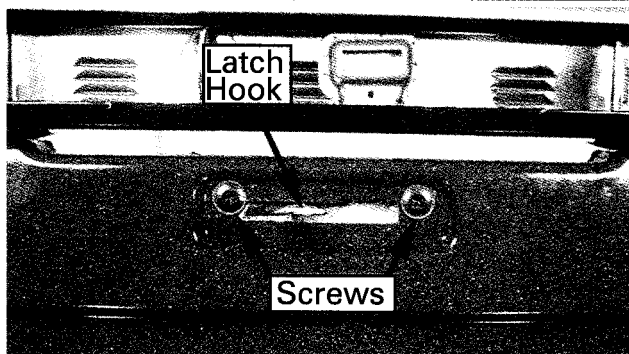
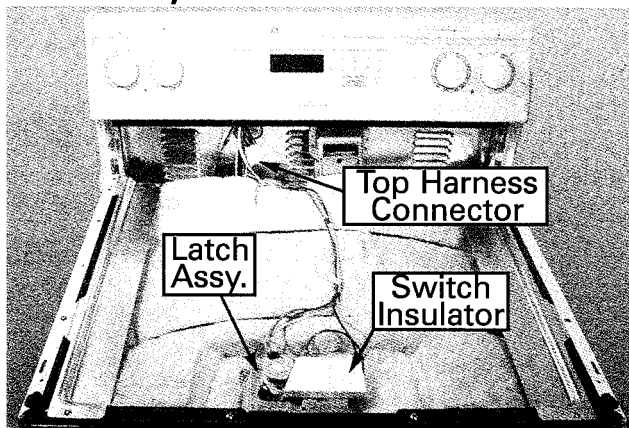

Backguard Access (Electric & Gas)

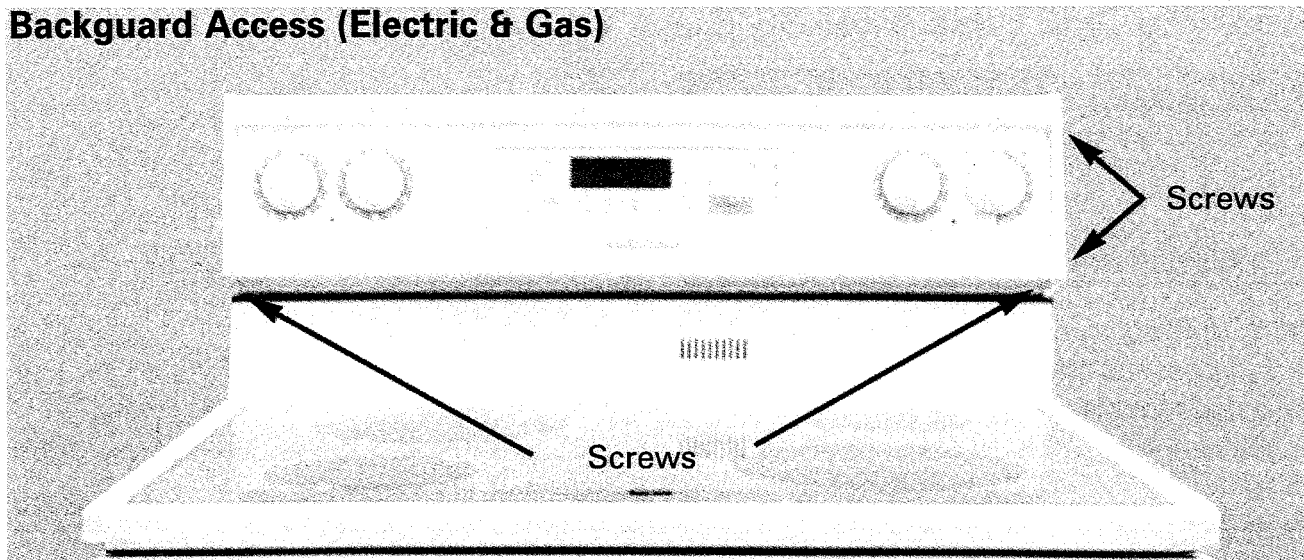

To access the control panel components, remove two (2) Phillips head screws from under the front outside corners of the backguard.

Note: It will be necessary to remove two (2) additional (1") Phillips head screws from one of the end caps to allow enough movement for easy removal of the control panel. Remember, these are highly visible parts and can be easily damaged.

Pull end cap outward only enough to slide the control panel forward. Carefully pull the bottom out at the end cap and lift off at the back top edge. Pull forward and place control panel on a protective covering on the range top to prevent damage to control panel or range. With the control panel removed and pulled forward, you have access to the infinite switches, dual control switch, oven light switch, indicator lights and the electronic control.

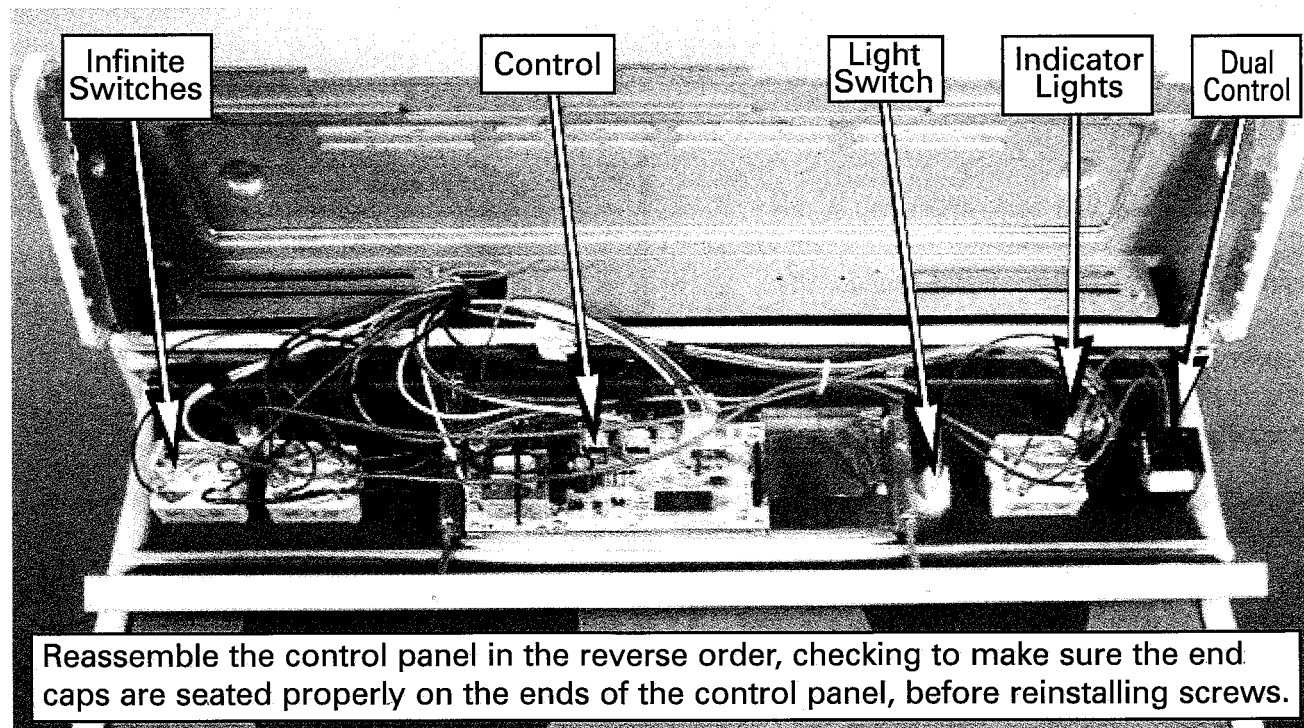

Reassemble the control panel in the reverse order, checking to make sure the end caps are seated properly on the ends of the control panel, before reinstalling screws.

Range Back Removal/Components (Electric)



The louvered back panel can be removed to access components from the rear. To remove, locate and remove the eight screws shown. You will find there are additional screws along the same edges, these secure the side panels and should be left in place.

Note: *Screws holding the back in place do not require removal for access to the terminal block. Remove the two screws on either side of the terminal block cover to gain access to those connections.*

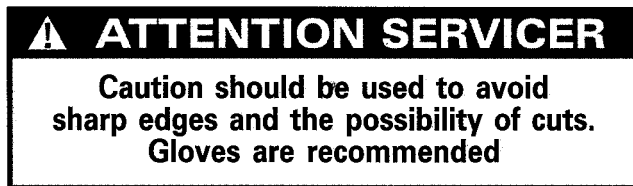
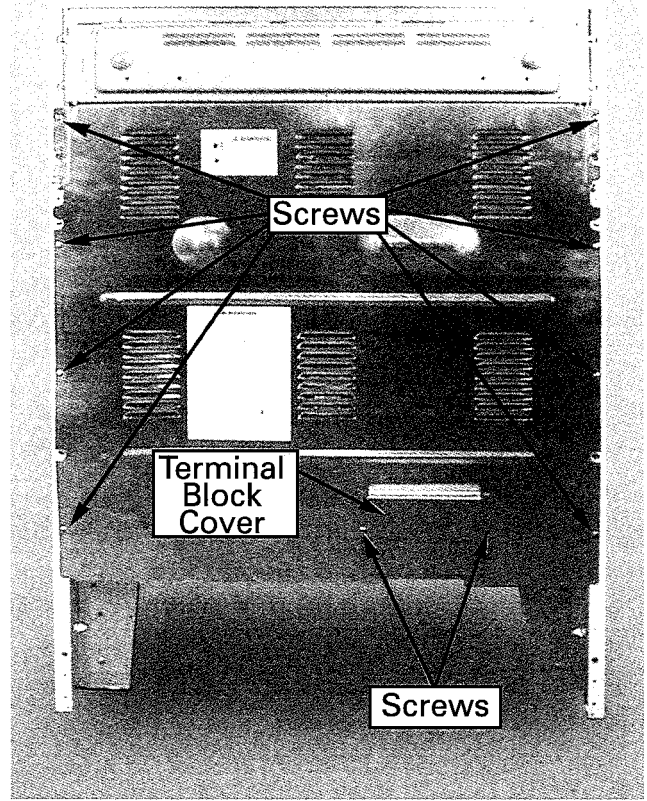

Once the range back is removed, the following components are accessible:

- Vent
- Oven Light Connections
- Broil Element Connections
- Convection Fan Motor
- Bake Element Connections
- Terminal Block

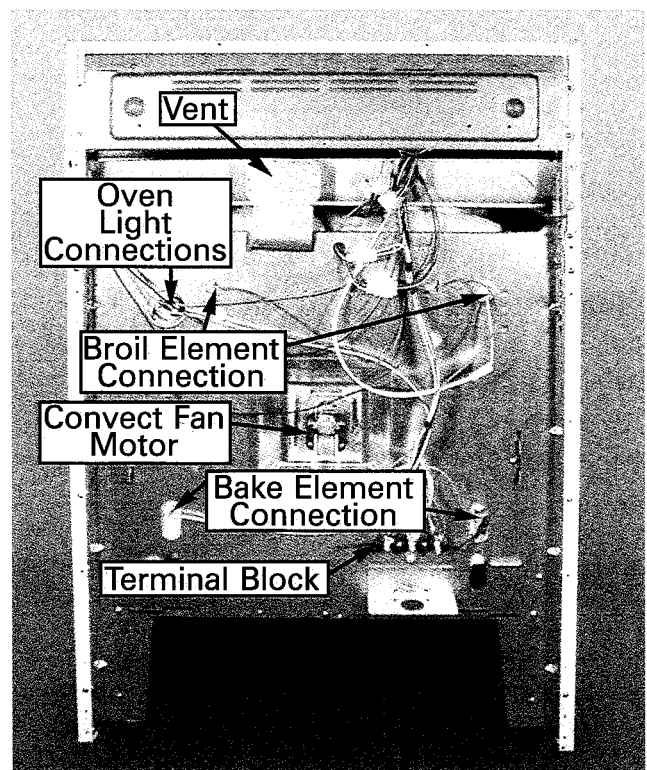

Door Light Switch and Hinge Removal



Remove the range top, remove seven phillips screws from the either rear edge that secure the side panels to the back of the range.

Remove two 1" screws that hold the right control panel end cap to the control panel (*electric only*). -OR- Remove three screws from the top edge of the side panel (*gas only*). This should loosen the side panel enough to pull up and disengage the "key hole" at the front inside of the panel (top & bottom) from the screw and plastic spacer holding it in place.

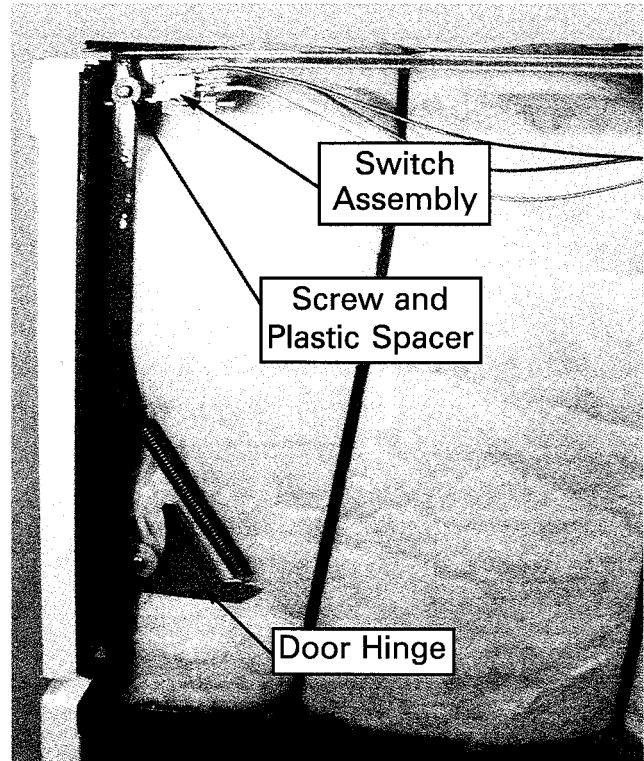

Removal of the side panels also allows access to the door hinges on either side of the range. Hinges are held in place by two hex head screws above and below the hinge opening in the front closure.

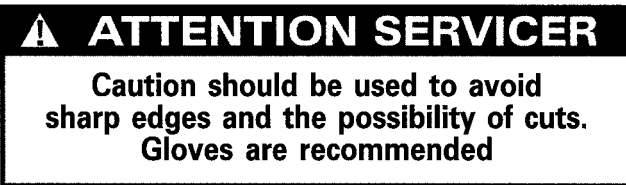

The switch mechanism is secured to the front closure by two phillips screws.

It is possible to replace this switch without removing the side panel if the range is tightly installed or access is inconvenient to the back of the appliance.

Remove the top and right support rail, this will allow access to the switch assembly.

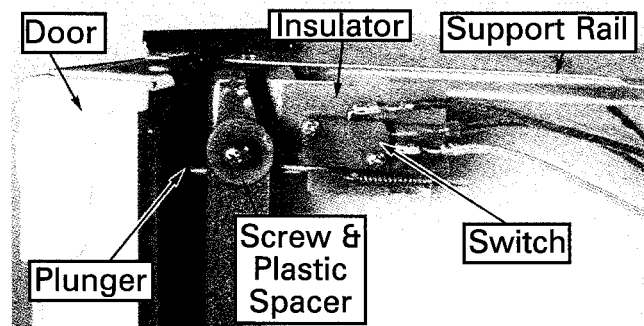
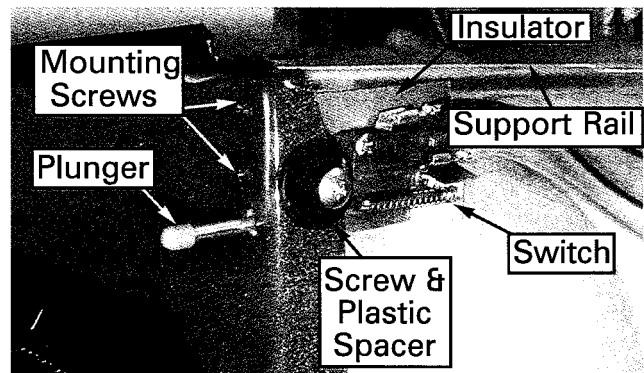

Spark Module Location



The spark module is located on the lower right side base rail as viewed from the front of the unit.

Remove the top and side panel (*see Removing Top Assembly (Gas)*).

Remove three screws from the rear and top edges of the side panel. This should loosen the side panel enough to pull up and disengage the "key hole" at the front inside of the panel (top & bottom) from the screw and plastic spacer holding it in place.

The spark module is mounted on a bracket on the base frame.

Note: Be sure all wires are "dressed" and out of the way when reinstalling the side panel.

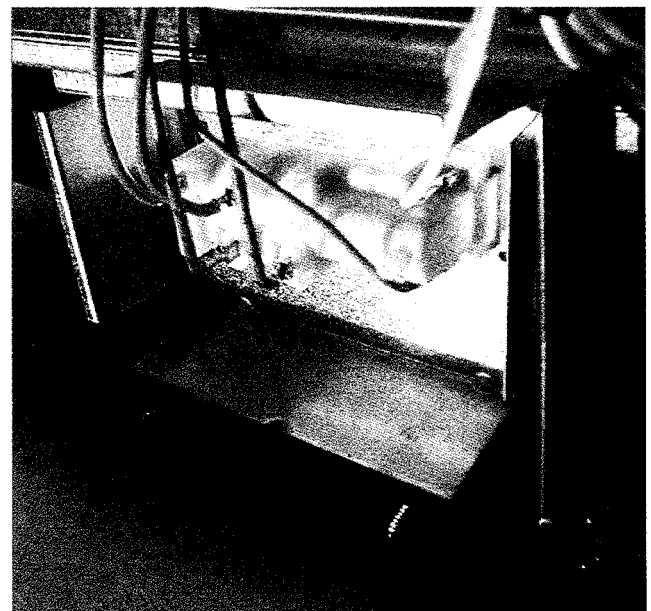
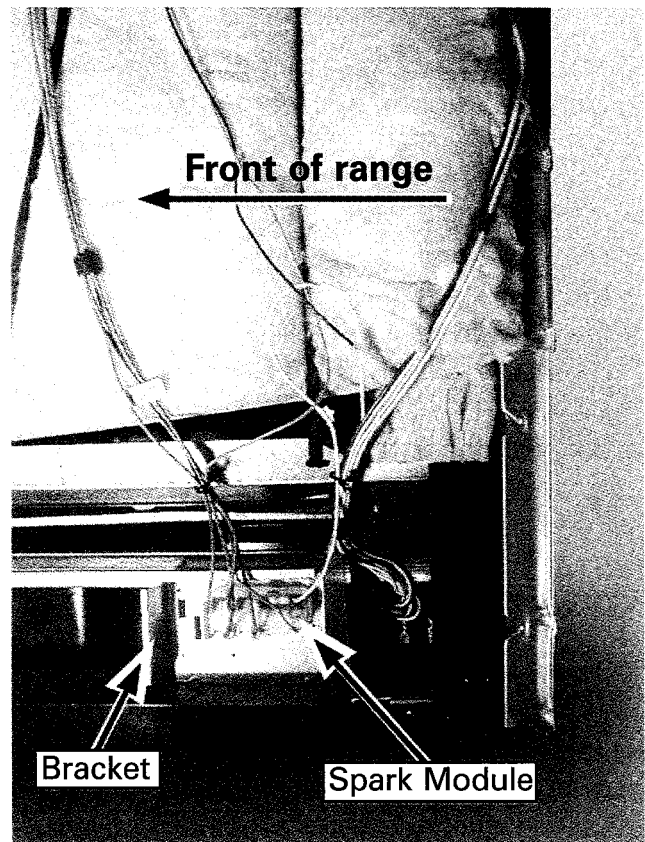
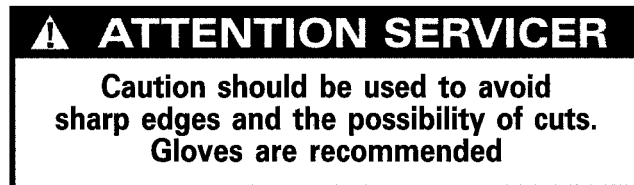

Oven Cavity Components (Electric)

Open or remove the oven door. The following components are accessible:

- Racks
- Oven Sensor
- Broil Element
- Oven Light (Receptacle, Bail Wire, Glass Cover)
- Convection Fan Cover
- Bake Element

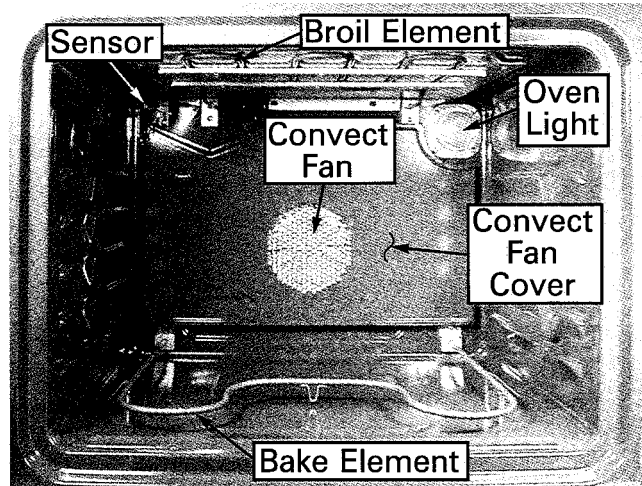

Convection Fan (Electric & Gas)

Remove six screws (as shown) from the perimeter of the convection fan cover. This will loosen the cover, but it cannot be removed easily without positioning it to clear the rack guides. Care should be used when moving parts and tools around inside the oven cavity to avoid marring or chipping the porcelain surfaces.

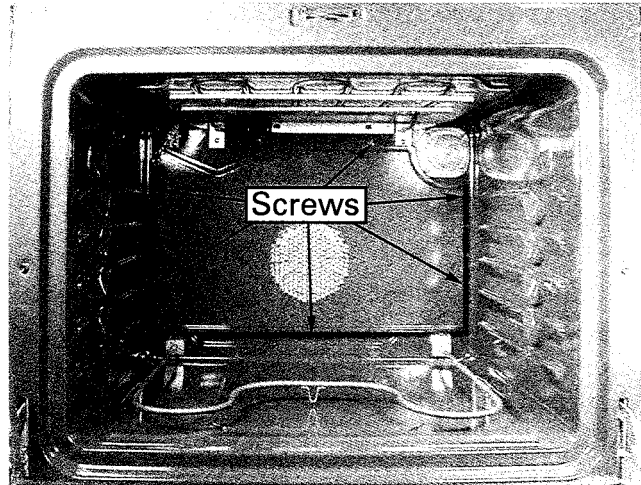

Three screws (shown) secure the convection fan mounting plate, remove these, to allow access to the motor and connectors.

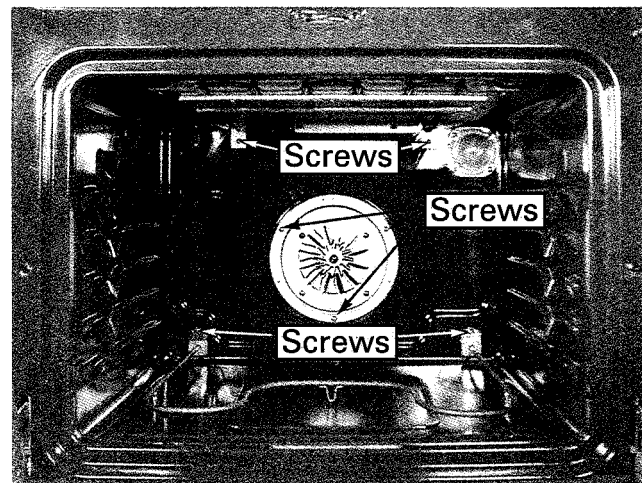

Also shown here are the screws that secure the bake and broil elements.

Convect Fan Motor and Blade (Electric & Gas)



After the convect fan mounting plate is removed, motor connectors, motor, motor mount and insulation is accessible. Motor connectors are also exposed by removing the back panel (*see range back removal*).

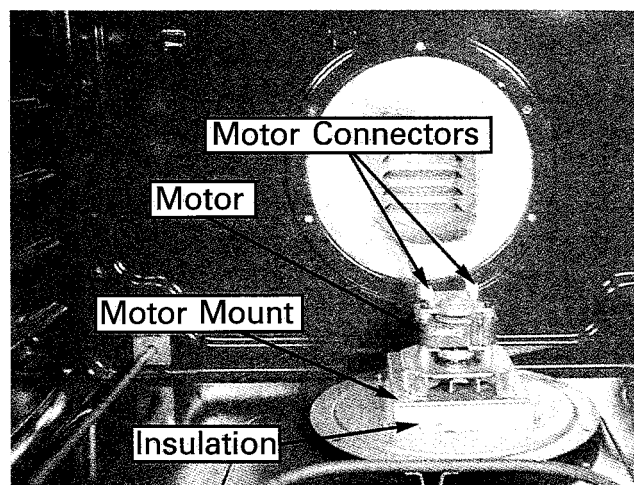

The convect fan blade is attached to the motor's "D" shaft using a hex set screw. The fan blade must be loosened and taken off the motor shaft before the motor can be removed. The motor mounting screws are found on the front side of the convect fan assembly. When reassembling, be sure to reinstall the small piece of insulation under the motor mount. The insulation provides sound dampening and prevents heat loss. When reinstalling the convect fan blade, be sure that the blade has adequate clearance at all points around the mounting plate. The blade should "stand off" approximately 1/8" with very little apparent warping.

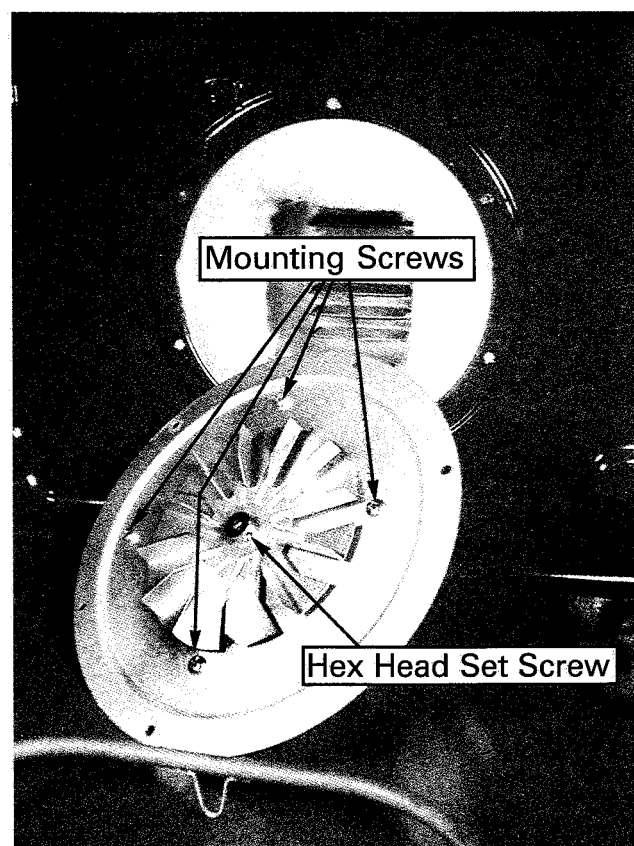

Note: When reinstalling the convect assembly, be sure to check that no loose insulation is visible in the fan area or anywhere in the oven cavity.

Oven Light (Electric & Gas)

The oven light is located at the upper right corner on the back wall of the oven cavity. The receptacle is held in place by four phillips head screws. The oven light assembly is made up of the following parts:

- Oven Light Receptacle assembly
- Appliance Rated Light Bulb
- Wire Bail
- Glass Cover

To replace bulb, while supporting the glass bulb cover, slide the wire bail to one side or the other to release the cover. Take care to have a secure hold on the cover as it is easily dropped and broken and/or may chip the oven cavity. Remove the cover and place in a safe area. Remove the bulb by twisting counter clockwise. Reassemble in reverse order. Make sure the glass cover is reinstalled correctly, it is designed to contain glass from the light bulb should it break.

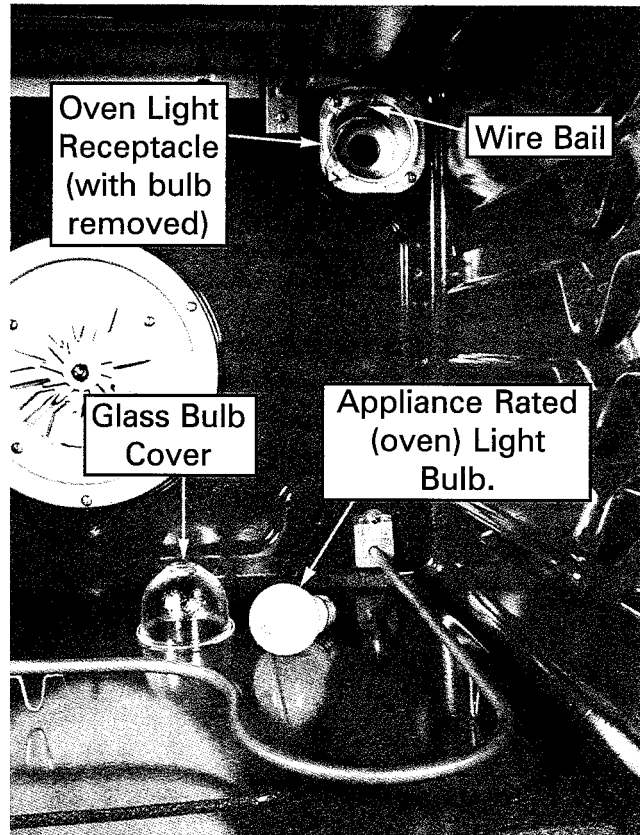

Note: Be sure to use only an appliance rated replacement bulb, standard bulbs may not withstand the heat and their base may become fused to the receptacle.

Manifold Panel Removal

1. Remove top (see *Removing the Top (Gas)*)
2. Remove knobs and bezels by grasping and pulling straight out.

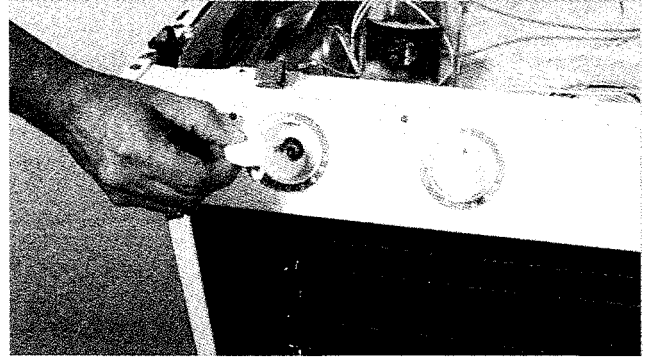

3. Remove six screws, two from on top of the panel and four at the location shown under the front edge of the panel on both sides.

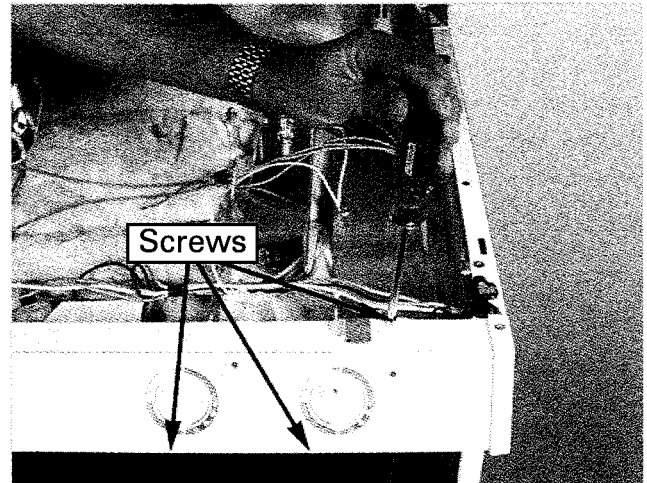

4. Grasp panel and pull straight forward.

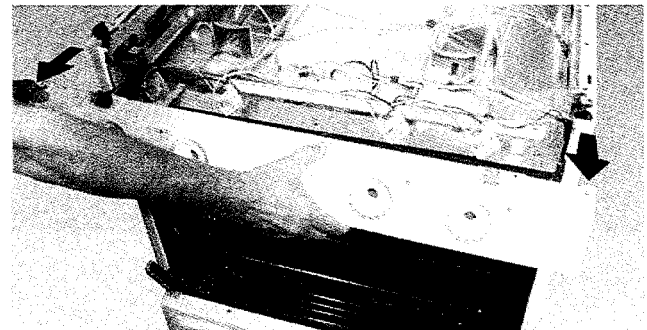

Note: When reassembling the manifold panel, be sure to line up the pins on the knob bezel with the brass holes on the valve switch. This will ensure the proper alignment of the indicators and secure the bezels to the unit.

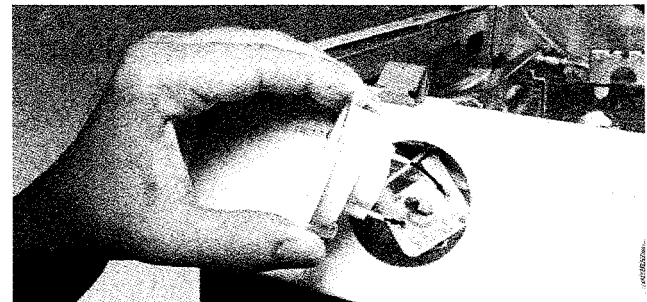

Valves and Swithes (Gas)

You now have access to the valves, valve switches, manifold and burner tubes.

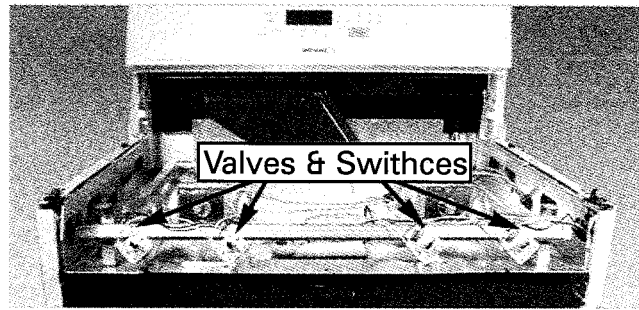

The valve switch snaps into place on the valve top. Be sure that when replacing the switch, it is oriented the same as the original with the connectors facing up and to the left.

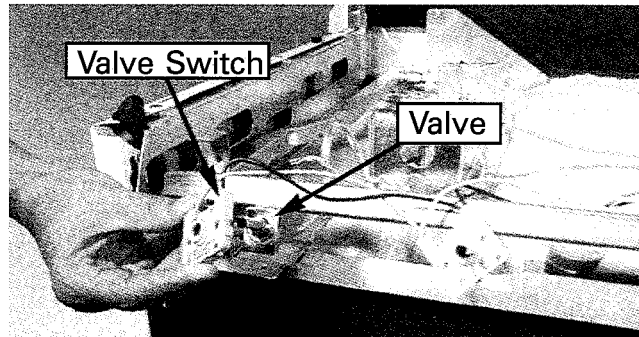

Using a 1/2" or adjustable wrench, loosen the the burner tube nut. Use care not to "strip" the threads on the valve when reassembling.

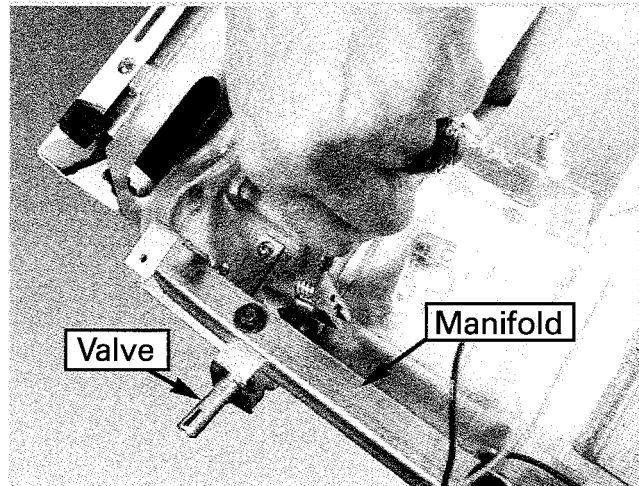

Using a 1/4" nut driver remove the screw that secures the valve to the manifold.

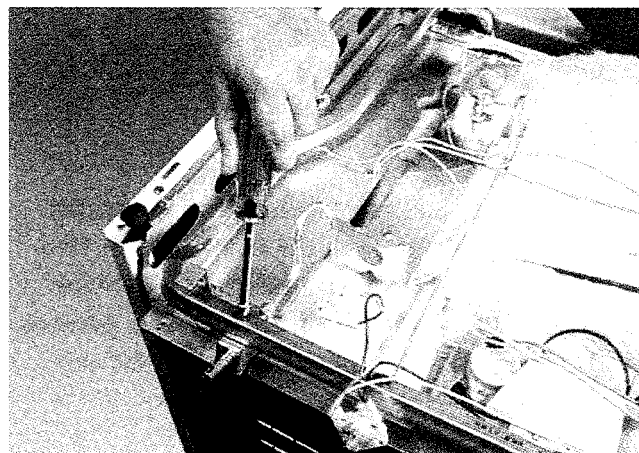

Valve Seals

Once the valve has been removed, thoroughly inspect the valve seals. If the seals appear broken or brittle replace them before reassembly.

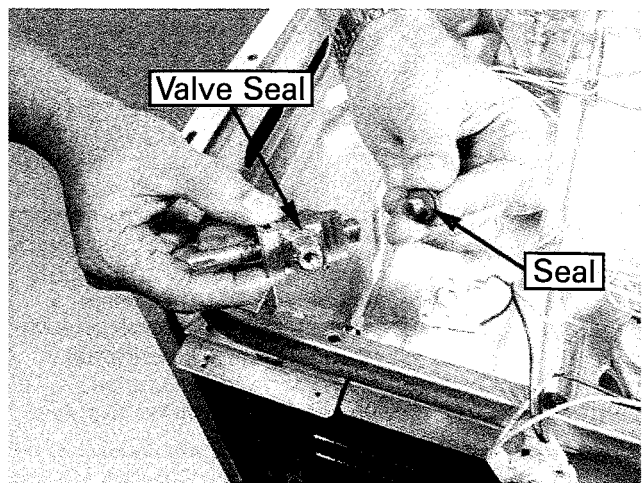

It's a good idea to use double seals when reinstalling the valve.

Oven Bottom Removal

1. Remove oven door and racks.
2. Remove the convection fan cover.
3. Pull the two tabs at the back of the oven bottom forward. Lift up the back edge far enough to disengage the "U" shaped flange at the front edge of the oven bottom from the front closure.

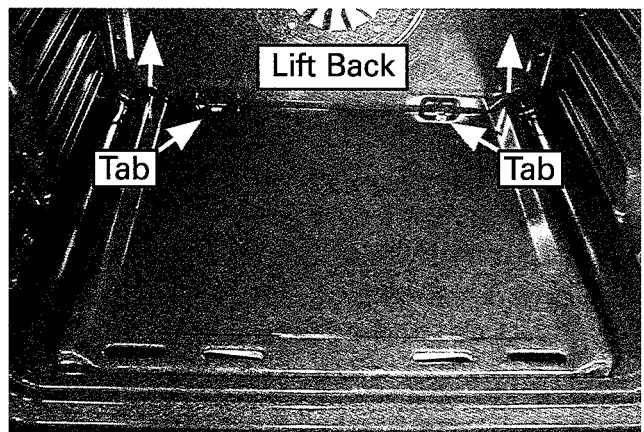

Bake Burner

Once the oven bottom is removed, the bake burner and ignitor are accessible.

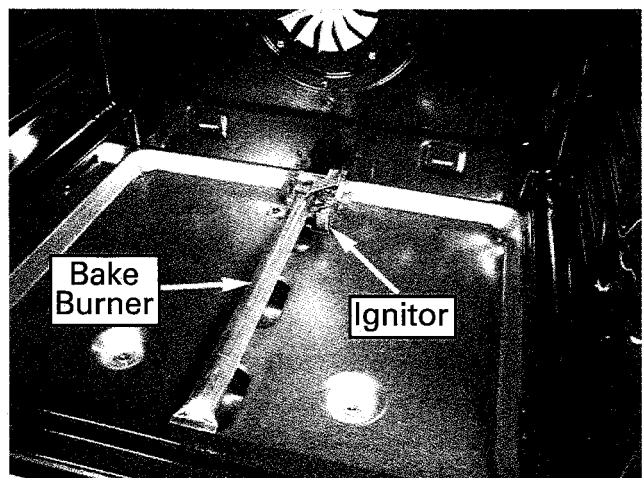

Broil Burner

The broil burner is simply mounted to the top of the oven cavity.

! IMPORTANT

Always be sure to check the appliance thoroughly for gas leaks after any service procedure.

Never check for leaks with an open flame!
Brush a solution of soap and water on connections and watch for the bubbles that will indicate a leak.

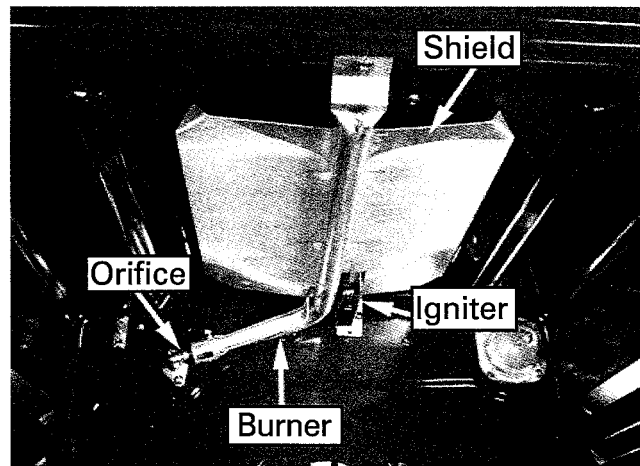

Oven Burner Adjustments

The approximate length of the flame of the oven burners is a 1/2 inch distinct inner blue flame.

The oven burner can be checked as follows:

1. Yellow flame on burner - open burner air shutter to the widest opening that will not cause the flame to lift or blow off the burner when cold.
2. Distinct blue flame but lifting - close the burner air shutter to the point where it will not cause the flame to lift or blow off the burner when cold.

The oven burner air shutter adjustment is the same on ranges with a gas pilot or electric ignition.

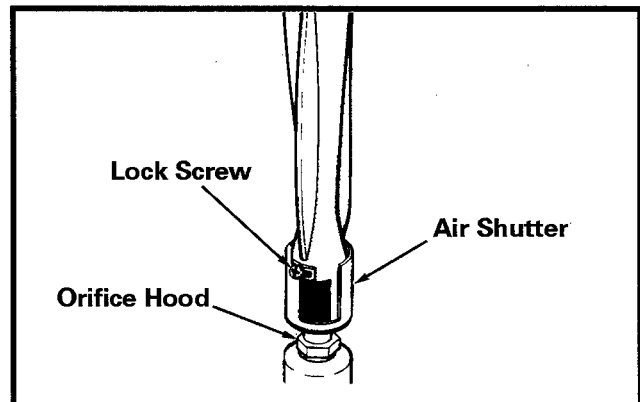
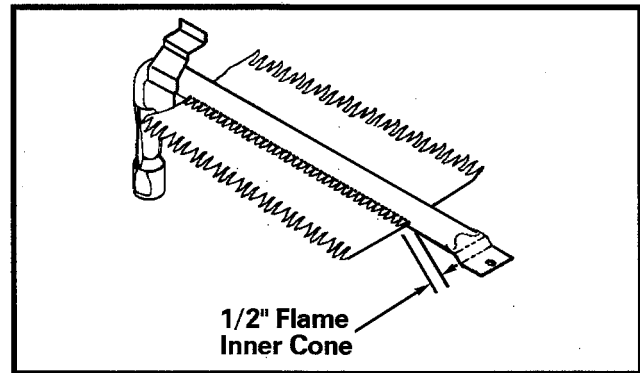

Top Burner Adjustments

The approximate height of the flame at the high or full-on is shown at the right.

Adjust the burner air shutter to the widest opening that will not cause the flame to lift or blow off the burner when cold.

Note: Correctly adjusted sealed burners, can have flames that will lift or blow off without a pot over the burner. These should be adjusted with a pot in place.

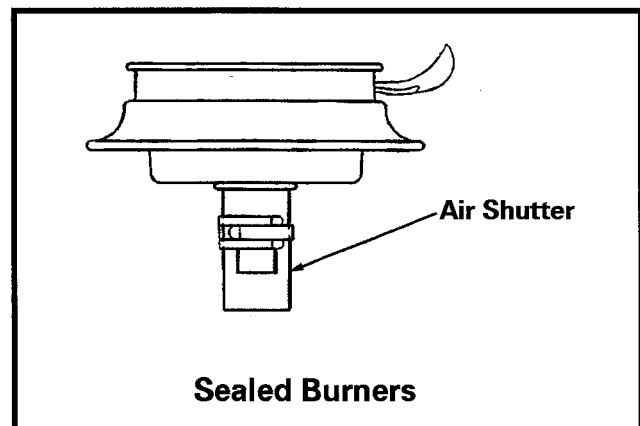

Appliance Regulator and Oven Valve Location

⚠ IMPORTANT
Always be sure to check the appliance thoroughly for gas leaks after any service procedure.

Never check for leaks with an open flame!
Brush a solution of soap and water on connections and watch for the bubbles that will indicate a leak.

Although you may find any one of the three regulator styles, they all have the same connections and mount in the same area.

The oven valve regulates the amount of gas delivered to the broil and bake burners. It is located just next and connected to the pressure regulator.

These components are located on the lower left (as viewed from the front) base rail behind the unit.

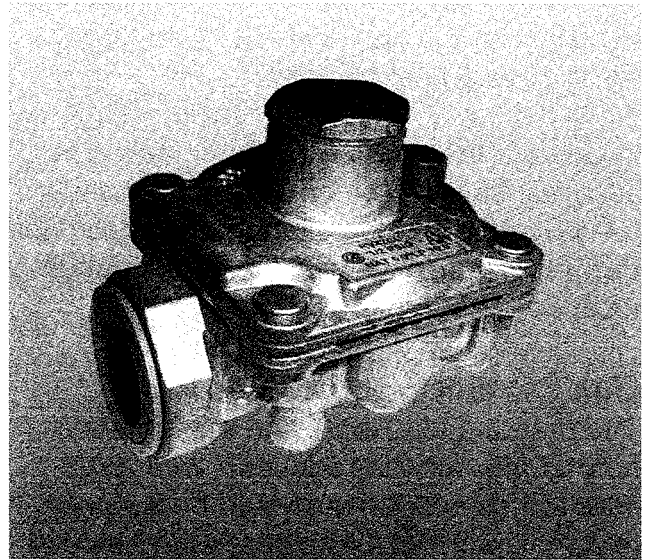

Shown above is one of the three different styles of pressure regulators that will be found on these products.

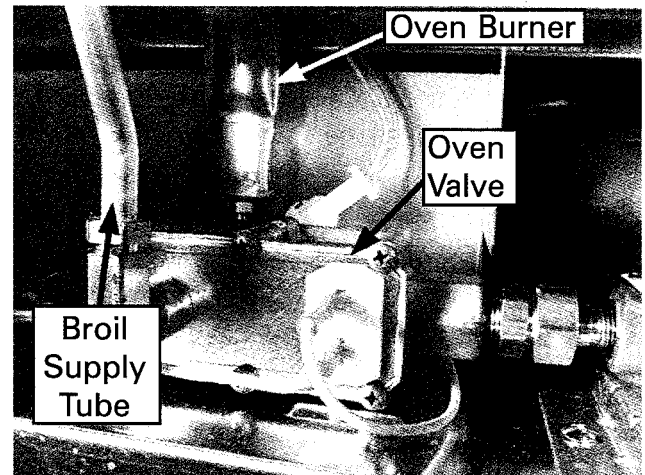

The above photo shows the oven valve and its connections.

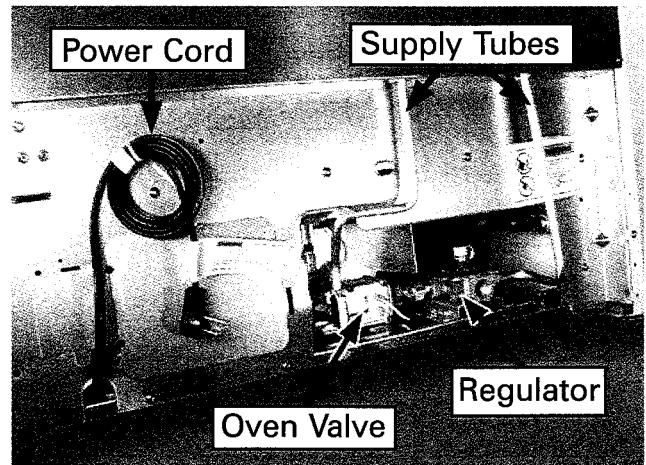

Gas Supply Connections

Installation of this range must conform with local codes or, in the absence of local codes, with the National Fuel Gas Code, ANSI Z223.1 latest edition.

In Canada the range must be installed in accordance with the current CGA standard CAN/CGA-B149 - Installation Codes for Gas Burning Appliances and Equipment and/or local codes.

Gas Pressure

The natural gas supply line must have a natural gas service regulator. Inlet pressure to this appliance should be reduced to a maximum of 14 inches water column (0.5 pounds per square inch (P.S.I.) liquefied petroleum (L.P.) propane gas supply line must have an L.P. pressure regulator. Inlet pressure to this appliance should be reduced to a maximum of 14 inches (0.5 P.S.I.). Inlet pressures in excess of 0.5 P.S.I. can damage the appliance pressure regulator and other gas components in this appliance and can result in a gas leak.

Gas Conversion

All ranges are equipped with double coaxial (universal) orifices and with a convertible appliance regulator. The unit model plate states which gas it was adjusted for at the factory. To convert the unit to either Natural or LP gas will require adjustment of the orifice hoods, air shutters on the burners and adjustment of the appliance regulator converter cap. Inlet pressure to the appliance pressure regulator should be as follows for both operation and checking of appliance pressure regulator setting:

Inlet pressure in inches of watercolumn	Natural	LP
Minimum	4	10
Maximum	14	14

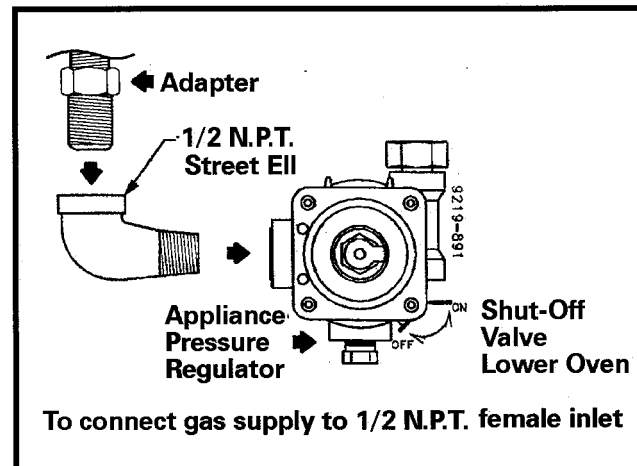
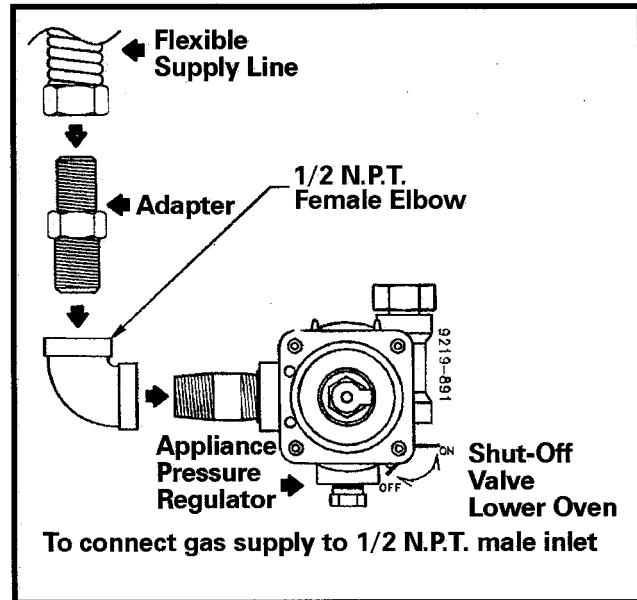

Shown is an example of one style of the appliance regulator converter cap. (this may differ from your unit) as shown on the following page.

Appliance Pressure Regulator Conversion

The unit appliance pressure regulator must be set to match the type gas supply used. If converting from natural gas to LP gas, the appliance regulator must be converted to regulate LP gas. If converting from LP gas to natural gas the appliance must be converted to regulate natural gas.

Note: To convert the appliance pressure regulator from one gas to another, do either (1), (2), or (3) at the right: your unit will be equipped with one of three appliance regulator types shown.

1. Remove the cap, push down and turn counterclockwise.
Turn cap over and reinstall.

Note: The gas type you are converting to must be visible on top of the installed appliance pressure regulator cap.

2. Remove plastic dust cover from cap nut on top of the regulator. Remove cap nut from the regulator (plastic dust cover comes off with nut). **IMPORTANT** remove plastic dust cover from cap and reinstall on opposite of cap nut.

Reinstall cap nut to appliance pressure regulator and replace dust cover. **CAUTION** be sure marking for the type of gas to which the regulator has just been converted is visible in top of cap nut before replacing plastic dust cover.

3. Remove cap and forcibly snap out plastic plunger from bottom of cap. Turn plunger over and forcibly snap back in original location.

Note: plunger must snap into position; the gas type you are converting to must be visible on the lower side of the plunger.

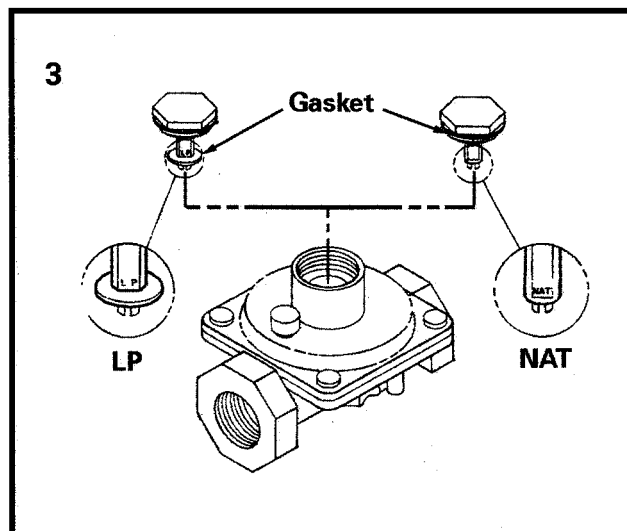
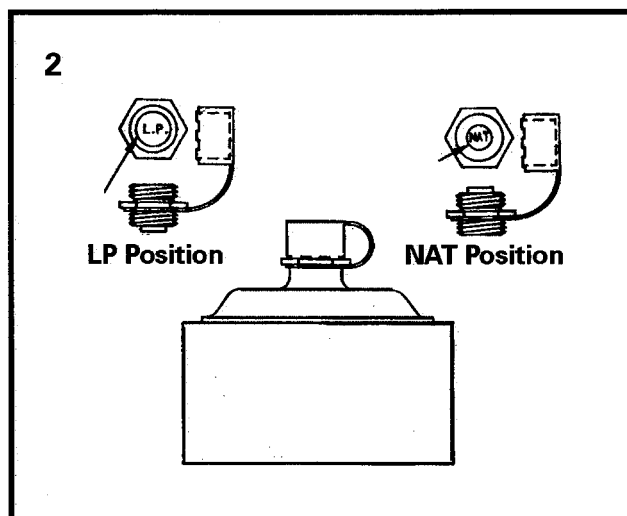
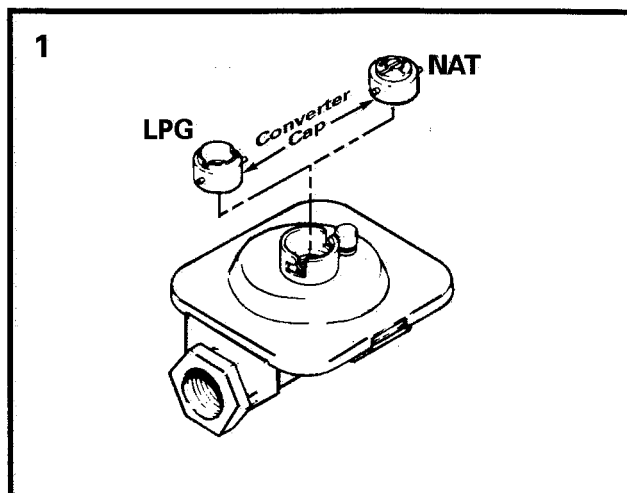

Orifice Conversion

1. From Natural gas to LP/Propane

- a. Change the appliance pressure regulator from natural to LP setting. (see *Appliance Pressure Regulator Conversion*)
- b. Screw the burner orifice hoods down tight against the pins. (see *figure 1b*) Use care not to over tighten. over tightening can damage the coaxial pin inside the orifice hood.

Note: On units using an Eaton Oven Safety Valve, screw the valve orifice hood down tight against the valve body. (see figure 1d) It is important that the hood be turned down as far as it can go to ensure that complete conversion has occurred.

- c. Models with standing pilots: Adjust burner pilots. Turn the selector switch on the face of the thermostat to the LP position.
- d. Adjust burner air shutter to the widest opening that will not cause the flame to lift or blow off the burner.

Note: Correctly adjusted sealed burners, can have flames that will lift or blow without a pot over the burner. These should be adjusted with a pot in place.

2. From LP/Propane gas to Natural gas

- a. Change the appliance pressure regulator (see *Appliance Regulator Conversion*) from LP to Natural setting.
- b. Screw the burner orifice hoods away from the pins. (see *figure 1a*) Approximately 1 1/2 to 2 turns.

Note: On units using Eaton Oven Safety Valve, screw the burner orifice hoods away from the pin (see figure 1c). Approximately 1 1/2 to 2 turns.

- c. Models with standing pilots: adjust top burner pilots. Turn the selector switch on the face of the thermostat to the NAT position.
- d. Adjust burner air shutter to the widest opening that will not cause the flame to lift or blow off the burner.

Note: Correctly adjusted sealed burners, can have flames that will lift or blow without a pot over the burner. These should be adjusted with a pot in place.

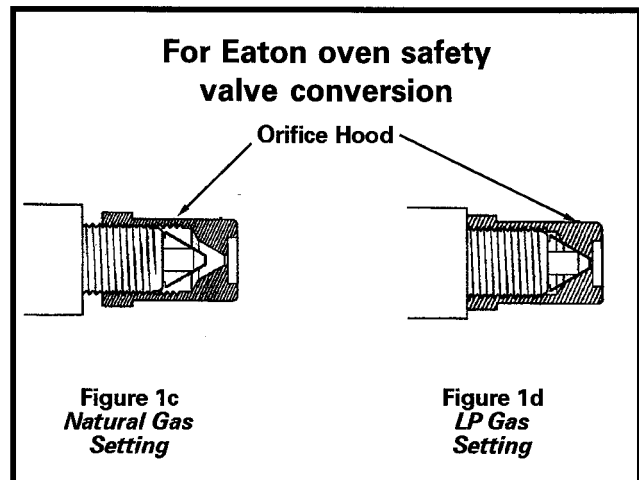
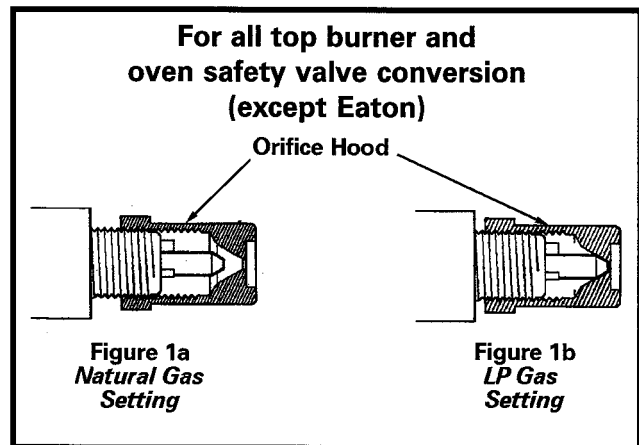

3. General Component Testing

Inputs

Line Voltage

Single phase AC voltage, L1 and Neutral, connected by means of two 0.250" quick connect tabs located on the circuit board.

For models with a dual-speed convection fan the power is expected to be switched off when the oven door is open.

Ground

Connection to chassis ground provides safety and noise immunity. The connection is made by mounting the conductive control chassis to the appliance chassis. The electrical circuit is connected to the control chassis by a screw contact.

Temperature Sensor

Connection to an isolated platinum RTD to measure oven cavity temperature, connected by means of two 0.045" square posts in a low voltage header. See resistance vs. temperature table in the temperature section of this document.

Broil Power (electric models)

L1 power supply for the bake element, connected by means of a 0.250" quick connect tab located on the relay.

Door Latch Locked

Connection to a SPST switch that closes when the latch is locked. The input is connected by means of a 0.045" square post in a lower voltage header.

Bake Power (electric models)

L1 power supply for the broil element, connected by means of a 0.250" quick connect tab located on the relay.

Door Latch Unlocked (motorized latch models)

Input for a switch that closes when the latch is unlocked. When the latch mechanism is moving between states there is a period where neither the locked or the unlocked switch is closed. The unlocked input is connected by means of a 0.045" square post in a low voltage header.

Broil and Bake Power (gas models)

L1 power supply for the bake and broil valve/ignitors, connected by means of a 0.250" quick connect tab located on the PCB.

Latch and Convection Fan Power (motorized latch and convection models)

Switched L1 supply to power motors for the door latch and convection fan. Power is expected to be switched off when the oven door is open.

Keyboard

A membrane keyboard is included, except on controls intended for certain wall ovens. Maytag supplies the decorative overlay for all models.

Auxiliary Fan Power (dual-speed convection and cooling blower models)

L1 power supply for either a dual-speed convection fan or a cooling blower.

Model Options

Option resistors and eeprom data included in the control are used to select model variations.

Outputs

Broil Element (electric models)

L1 power for a resistive heating element above the oven cavity, switched by a relay on the control and connected by means of a 0.250" quick connect tab located on the relay.

Bake Power (electric models)

L1 power for the bake element, connected by means of a 0.250" quick connect table located on the broil relay. This output is intended to be connected directly to the bake power input for electric models.

Bake Element (electric models)

L1 power for resistive heating element below the oven cavity, switched by a relay on the control and connected by means of a 0.250" quick connect tab located on the relay.

Broil Gas Valve (gas models)

L1 power for a bake gas valve/ignitor, switched by a relay on the control and connected by means of a 0.250" quick connect tab on the circuit board. The control circuit is designed such that this output is enabled only when the bake gas valve output is off.

Bake Gas Valve (gas models)

L1 power for a bake gas valve/ignitor, switched by a relay on the control and connected by means of a 0.250" quick connect tab on the circuit board.

Convection Fan (convection models)

L1 power for a convection fan motor, switched by a relay in the control and connected by means of a 0.250" quick connect tab on the circuit board. For dual-speed convection models this output powers the low speed.

Auxiliary Fan (dual-speed convection and cooling blower models)

L1 power for either the high speed of a dual-speed convection fan or a cooling blower, switched by a relay on the control and connected by means of a 0.250" quick connect tab on the circuit board.

Door Latch Motor (motorized latch models)

L1 power for a latch motor, switched by a relay on the control and connected by means of a 0.250" quick connect tab on the circuit board.

Latch Pulse

A signal fed to the latch state switches, connected by means of a 0.045" square post in a low voltage header.

Double Link Break Relay Control (Canadian models)

Output to drive the coil of an off-board single-pole, double-throw relay, connected by means of two 0.045" square posts in a low voltage header. The relay is not included as part of the control unit.

Display

A two-color vacuum fluorescent display is included on the control. Graphics include time display, temperature display, status word prompts, and oven icons.

Audio Annunciator

A ceramic piezoelectric beeper is included on the control unit.

Fused Neutral (Canadian models)

Provides a connection to neutral through a 5.6Ω fusible resistor. This is intended to be connected to the normally closed contact of the external double line break relay to allow complete dielectric testing of the appliance.

T1 Electronic Range Control (ERG)*

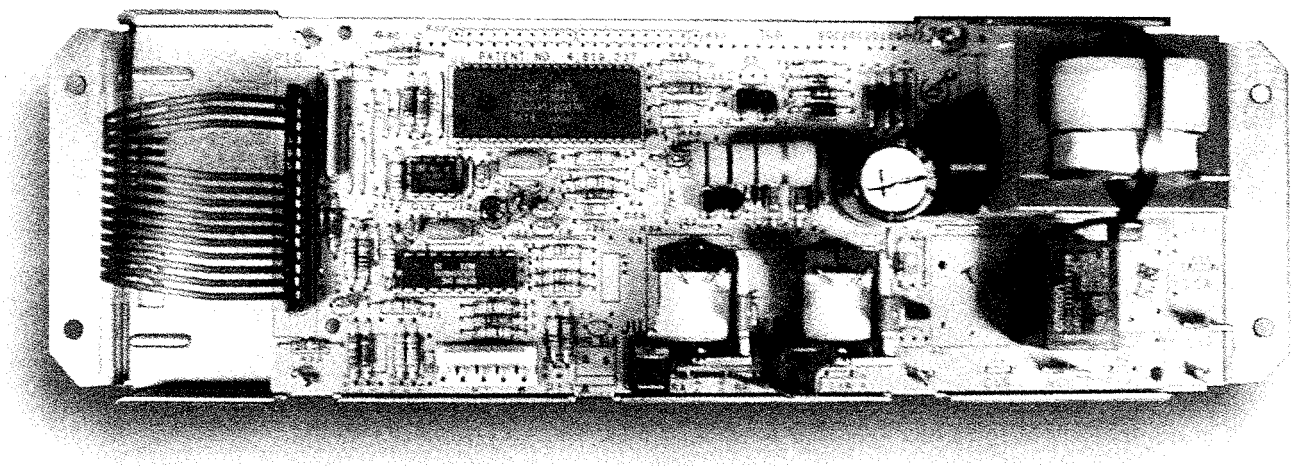
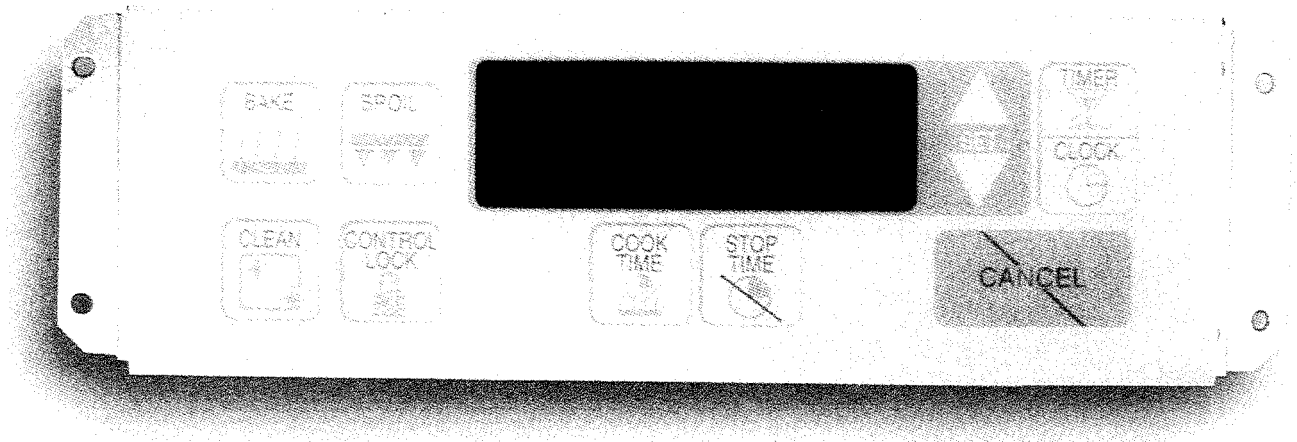

* Graphics may vary depending on model

T2 Electronic Range Control (ERG)*

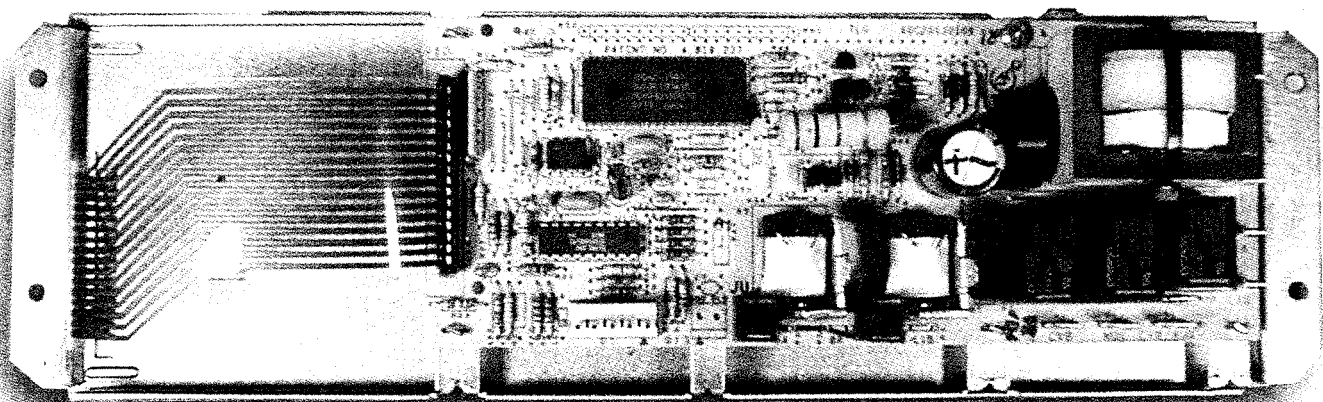
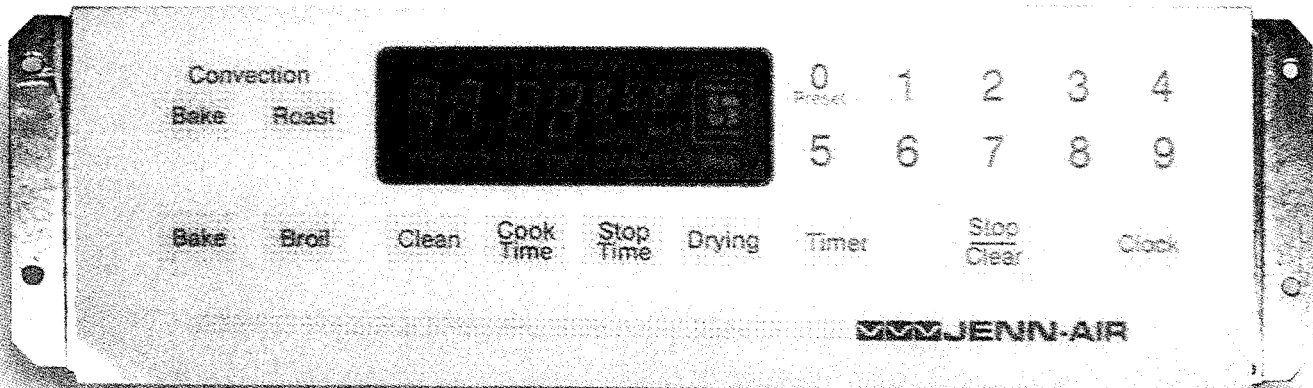

* Graphics may vary depending on model

RS1 Electronic Range Control (ERG)*

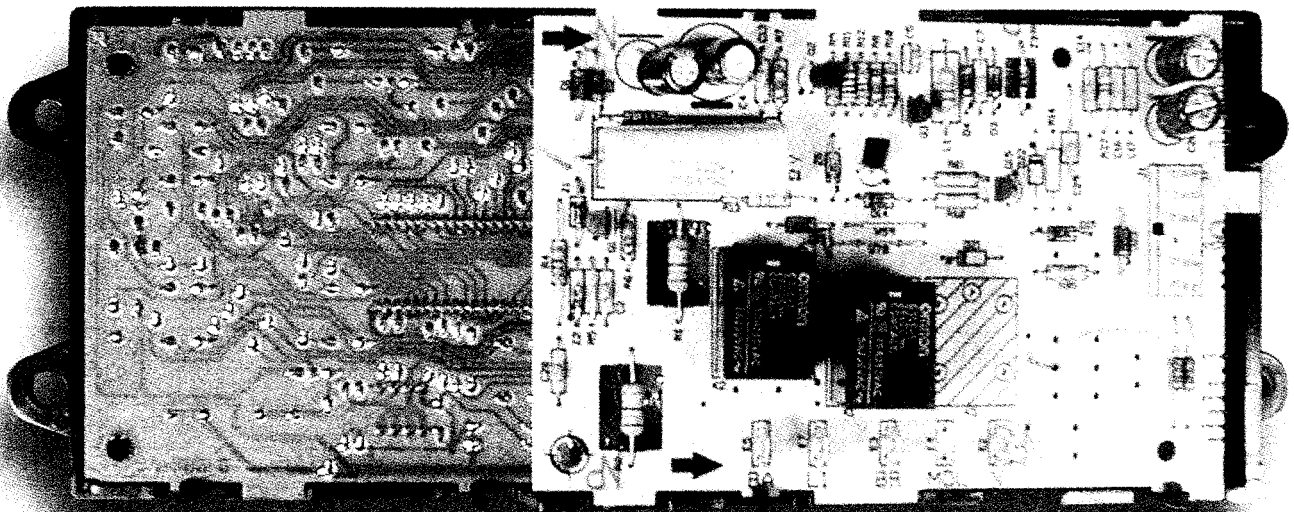
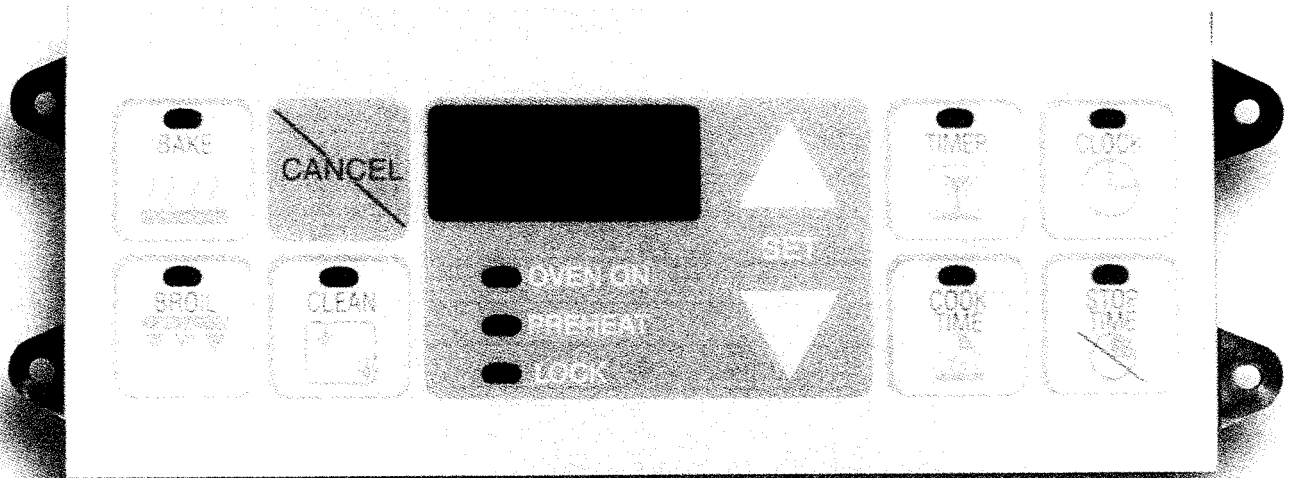

* Graphics may vary depending on model

Key Pin-Out for T1 Controls

KEY PIN-OUT FOR T1	KEY TAIL	MICRO PINS	PORTS
Cancel	10, 11	12	R30
Timer	8, 9	3, 2	R01, R00
Broil	2, 12	15, 4	R33, R02
Clean	2, 13	15, 13	R33, R31
Cooktime	13, 14	13, 3	R31, R01
Stoptime	12, 13	4, 13	R02, R31
Up	2, 3	15, 14	R33, R32
Down	2, 9	15, 2	R33, R00
A (Bake/ConvBake)	14, 15	15, 5	R01, R03
B (Bake/ConvBake/Roast)	2, 15	15, 5	R33, R03
C (Bake/Broil)	2, 14	15, 3	R33, R01
D (Dry/Lock/Clock)	9, 12	2, 4	R00, R02
E (Clock/Timer)	7, 8	4, 3	R02, R01

Key Pin-Output for T2 Controls

KEY PIN-OUT FOR T2	KEY TAIL	MICRO PINS	PORTS
Cancel	10, 11	12	R30
Clock	7, 8	4, 3	R02, R01
Timer	8, 9	3, 2	R01, R00
Cooktime	13, 14	13, 3	R31, R01
Stoptime	12, 13	4, 13	R02, R31
0/Preset	2, 9	15, 2	R33, R00
1	2, 3	15, 14	R33, R32
2	3, 6	14, 5	R32, R03
3	4, 6	13, 5	R31, R03
4	3, 4	14, 13	R32, R31
5	3, 9	14, 2	R32, R00
6	3, 8	14, 3	R32, R01
7	3, 7	14, 4	R32, R02
8	6, 7	5, 4	R03, R02
9	4, 5	13, 2	R31, R00
F (Bake/ConvBake)	14, 15	3, 5	R01, R03
G (Bake/ConvBake/Roast)	2, 15	15, 5	R33, R03
H (Bake/Broil)	2, 14	15, 3	R33, R01
I (Broil/Clean)	2, 12	15, 4	R33, R02
J (Clean/no function)	2, 13	15, 13	R31, R00
K (Dry/Lock/no function)	9, 12	2, 4	R00, R02

Temperature Sensor (Ohms vs. Temp)

5.0" tube, 1000 ohms at 0° C, alpha = 0.00375 ohm/ohm/° C			
<u>Degrees F</u>	<u>Ohms</u>	<u>Degrees F</u>	<u>Ohms</u>
0	932.069	500	1949.962
10	953.340	510	1969.372
20	974.572	520	1988.746
30	995.766	530	2008.082
40	1016.922	540	2027.381
50	1038.042	550	2046.642
60	1059.124	560	2065.867
70	1080.169	570	2085.054
80	1101.177	580	2104.205
90	1122.148	590	2123.318
100	1143.981	600	2142.392
110	1163.978	610	2161.433
120	1184.837	620	2180.435
130	1205.659	630	2199.399
140	1226.445	640	2218.326
150	1247.192	650	2237.217
160	1267.903	660	2256.070
170	1288.577	670	2274.886
180	1309.213	680	2293.665
190	1329.812	690	2312.406
200	1350.374	700	2331.111
210	1370.899	710	2349.778
220	1391.387	720	2368.408
230	1411.838	730	2387.001
240	1432.251	740	2405.557
250	1452.628	750	2424.076
260	1472.967	760	2442.557
270	1493.269	770	2461.002
280	1513.534	780	2479.409
290	1533.762	790	2497.779
300	1553.952	800	2516.112
310	1574.106	810	2534.408
320	1594.222	820	2552.666
330	1614.301	830	2570.888
340	1634.348	840	2589.072
350	1654.343	850	2067.219
360	1674.316	860	2625.330
370	1694.246	870	2643.402
380	1714.140	880	2661.438
390	1733.996	890	2679.437
400	1753.815	900	2697.398
410	1773.597	910	2715.322
420	1793.341	920	2733.210
430	1813.049	930	2751.059
440	1832.720	940	2768.872
450	1852.353	950	2786.648
460	1871.949	960	2804.386
470	1891.508	970	2822.088
480	1911.030	980	2839.752
490	1930.514	990	2857.379

Ratings

Ratings	Electric	Gas
Line input voltage, domestic models	120 Vac	120 Vac
Line input voltage, export models	230 Vac	230 Vac
Line input frequency, domestic models	60 Hz	60 Hz
Line input frequency, export models	50/60 Hz	50/60 Hz
Electronics assy operating temperature	105° C	105° C
Keyboard assy operating temperature	95° C	95° C
Bake/Broil output voltage	230 Vac	120 Vac
Bake output current	11.7 Aac	4 Aac
Broil output current	17 Aac	4 Aac
Fan output voltage	120 Vac	120 Vac
Convection fan output current	1.0 Aac	1.0 Aac
Convection fan locked rotor current	1.0 Aac	1.0 Aac
Auxiliary fan output current	1.0 Aac	1.0 Aac
Auxiliary fan locked rotor current	1.0 Aac	1.0 Aac
Latch motor voltage	120 Vac	120 Vac
Latch motor current	0.6 Aac	0.6 Aac
Latch motor locked rotor current	0.6 Aac	0.6 Aac
Double line break drive voltage	32 Vdc	32 Vdc
Double line break drive current	60 mAdc	N/A

Maximum Operating Conditions	Min	Max	Units
Line voltage, domestic	102	132	Vac
Line voltage, export	195	264	Vac
Power interruption with memory retention	0.5	---	s
Operating ambient temperature	0	105	°C
Humidity	5	95	%RH
Storage temperature	- 20	85	°C
Product life	---	20	years
Cook usage	---	187	hours/year
Self-clean usage	---	4	times/year
Bake and broil relay contact life	---	240,000	cycles
Door, unlock signal current	100	---	uA
Door, lock signal current	100	---	uA
Beeper frequency	1.95	2.05	KHz
Beeper volume (@ 100 mm)	85	95	dba
Display refresh rate	100	120	Hz
Membrane switch actuation force	12	28	oz
Actuation force variance from key to key on a control	--	15	oz
Keyboard resistance, chassis to connector, non-cancel	1.5	114	Kohms
Keyboard resistance, chassis to connector, Cancel	1.5	9.8	Kohms
Keyboard resistance from pin 1 to pin 16	4.5	13	Kohms
Resistance of open latch switch	10	--	Mohms
Resistance of closed latch switch	--	100	ohms
Tolerance of the relay switch point for 350° F bake	--	5	° F
Tolerance of the relay switch point for a self-clean	--	10	° F

Spark Ignition System

The primary components of the spark ignition system are: •**Spark Module** •**Surface Igniters** •**Oven Igniter** •**Top Burner Valve Switches** and •**Oven Control Switch**.

These parts are added to those basic to any gas (standing pilot ignition) range: pressure regulator, manifold, top burner valves, gas oven control, safety valve, surface burners and oven burner. The spark ignition system eliminates standing pilots from surface burners and only provides gas for the oven pilot whenever the oven is being used.

All of the switches on the spark ignition system are normally **open** and wired in parallel. The spark module converts 120 VAC to high (14-16,000) volts DC with very low (4 milliamps) amperage to generate the pulsating sparks which ignite the surface burner or oven pilot.

Turning any top valve handle or knob to the lite (start) position or turning the oven control dial ON closes the electric circuit to the spark module which allows all of the igniters on the range to spark. This means that as long as you have one switch operable (assuming you have electricity) the entire range may be used with ignition by spark.

The top burner system is purely a manual system. The switch must be closed to generate spark, and reopened (by turning the knob to the desired flame height after ignition) to stop the sparking. Surface burners must light within four (4) seconds.

The oven spark ignition is not a manual system. The oven spark may be activated by advancing the oven dial from OFF to the desired oven temperature. Turning the dial from the OFF position closes the contacts within the push on switch mounted over the gas oven control stem, and generates the spark. Once the spark has lighted the oven pilot, and the module senses a small amount of current passing through the pilot flame, the module ceases sparking. This is a result of the **re-ignition** (REIG) circuit within the module, thus the sparking stops automatically.

Should something happen to the pilot - be blown out or just wiggled away from the electrode - the module senses the absence of current through the pilot flame and will automatically start sparking again to relight the pilot. It will continue to spark until the pilot is reignited and the current sensing circuit is satisfied.

Once the oven pilot has been lighted and the sparking stopped automatically, the oven sequence is the same as on any standing pilot range. The standing pilot will grow to a heater pilot and the safety valve capillary will be warmed to allow main gas to the burner (after about 45 to 60 seconds) which will be ignited by the pilot. The oven temperature will begin to rise. When the oven control senses that the oven has reached the appropriate temperature, the heater pilot goes away, leaving the standing pilot. This causes the safety to close and cycle the burner off. Oven temperature begins to cool slightly from the set temperature and again the heater pilot will emerge to reopen the safety valve and relight the oven burner. This cycle will continue until the oven control is turned to the OFF position.

Once a surface burner has been lighted and the sparking stopped manually or the oven turned on and the sparking stopped automatically, the range will operate the same as any standing pilot type range.

Ranges equipped with spark ignition may be used in the event of electrical power outage. Surface burners may be lighted directly with a match. Being **cautious**, hold a lighted match to the desired surface burner and turn the burner valve handle to start or light position.

(NOTE: The Use and Care manual gives consumers appropriate directions for match lighting burners or oven pilot.)

To light the oven pilot with a match - **again use caution** - access the oven pilot through the **broiler compartment** with a lighted match, turn on the oven control, light pilot and remove hand.

Approximately 45 seconds after lighting the pilot, the oven burner will come on. Upon completion of the baking or broiling evolution, turn the oven control completely off. This will eliminate the possibility of any pilot gas escaping.

The primary difference between a standing pilot oven control and the gas oven control used on a spark ignition range is that the standing pilot system *always* has a flow of gas to the constant pilot while the spark ignition gas control will only allow pilot gas to flow with the oven control turned on. The spark ignition system *requires* a good continuous *ground* and correct *polarity* for proper operation.

Glow Bar Ignition

The primary components of this ignition system are: •**Electric Oven Control** •**Silicon Carbide Igniter** and •**Electric Oven Valve**. These components are all wired in series and although the oven control and glow bar require 120 VAC, 60 Hz - the oven valve operates on low voltage - about 3 volts. **120 VAC should never be applied directly to the oven valve terminals.** The glow bar is the power source for the oven valve.

Glow Bar Operating Parameters

Glow Bar Igniter	
Electrical	120 VAC, 60 Hz
Max Temperature	2650° F.
Amps	3.2 to 3.6 at 116 VAC
Resistance	50 to 400 ohms (cold) ambient temp. 75° F.

OVEN VALVE	
Electrical Rating	
3.2 amps at 2.94 volts AC	
3.6 amps at 3.3 volts AC	

Valve Igniter

Electrical steady state current through series connected igniter and valve circuit is between 3.2 and 3.6 amps at 120 VAC.

Glow Bar Operation

1. When the thermostat is turned on, cycling contacts are made and the series igniter-valve is energized.
2. As current begins to flow, the igniter starts to heat and its resistance decreases.

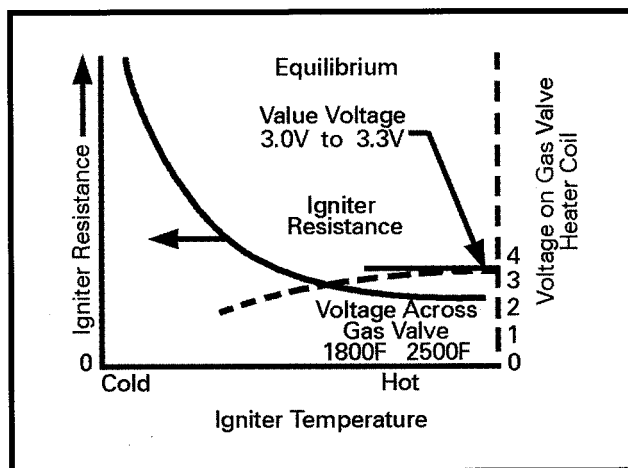

3. As the igniter resistance decreases, the current flow through the low resistance heater coil of the special gas valve increases. (This is represented in the diagram by a gas valve voltage drop curve.)
4. The gas valve opens and ignition occurs when three (3) volts are developed across the gas valve heater coil. The gas valve does not open until after the igniter has reached gas ignition temperature.
5. As the igniter approaches its maximum temperature of 2650° F. its resistance now starts to increase. The limiting of equilibrium current flow is approximately 3.6 amps.
6. When the oven reaches temperatures the thermostat cycling contacts open, the electrical circuit is broken. The gas valve shuts off the gas glow and the igniter cools.
7. To maintain oven temperature, the previous operating cycle repeats.

4. Wiring and Model Specific Information

Jenn-Air Models:

JGR8750ADB JGR8750ADQ JGR8750ADW JGR8850ADB JGR8850ADQ
 JGR8850ADW JGR8855ADS

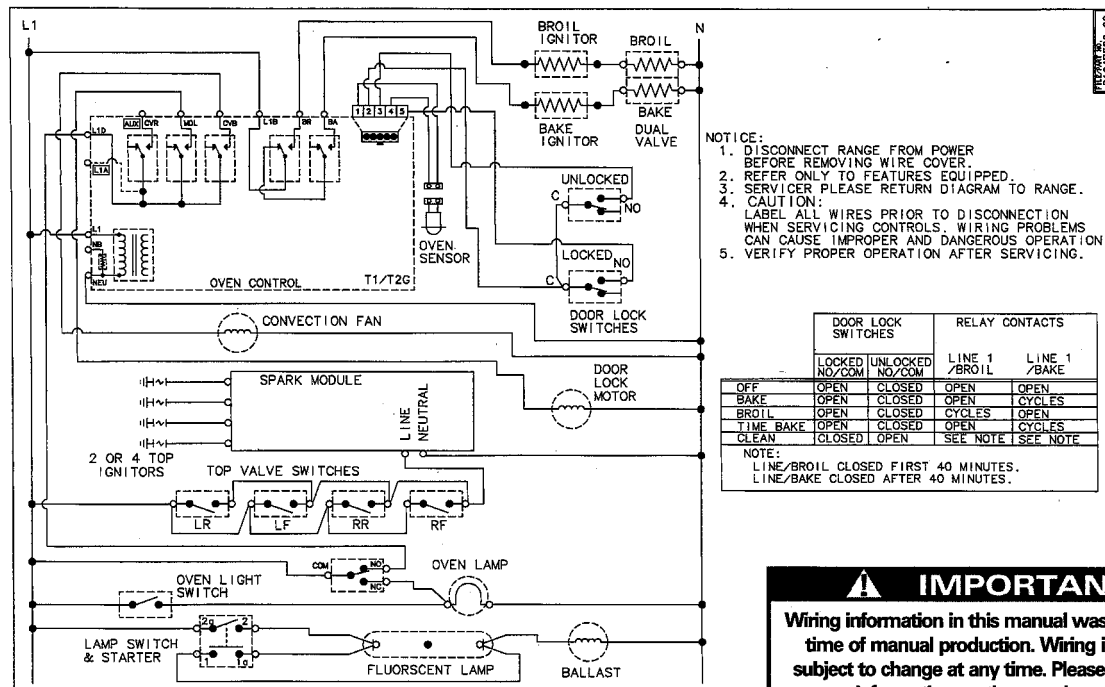
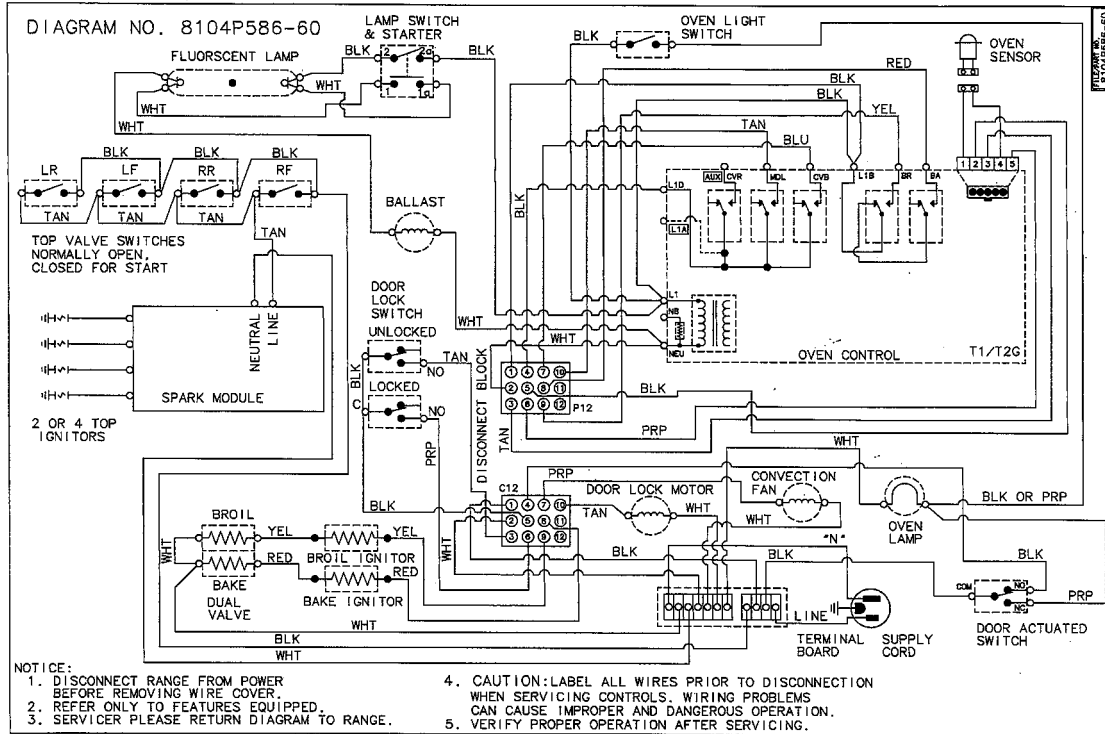

IMPORTANT
 Wiring information in this manual was accurate at the time of manual production. Wiring information is subject to change at any time. Please refer to wiring information on the actual product for most current information.

JER8750AAB JER8750AAQ JER8750AAW JER8850AAB JER8850AAQ JER8850AAW
 JER8855AAS

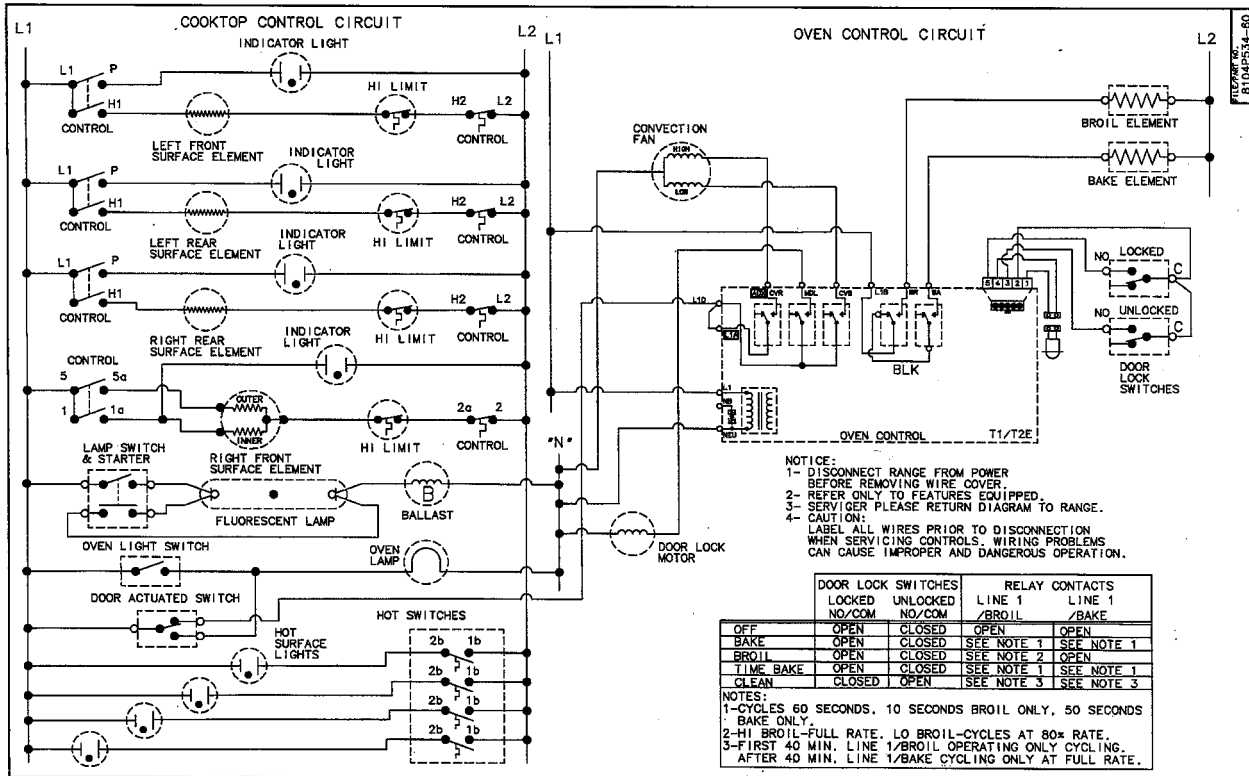
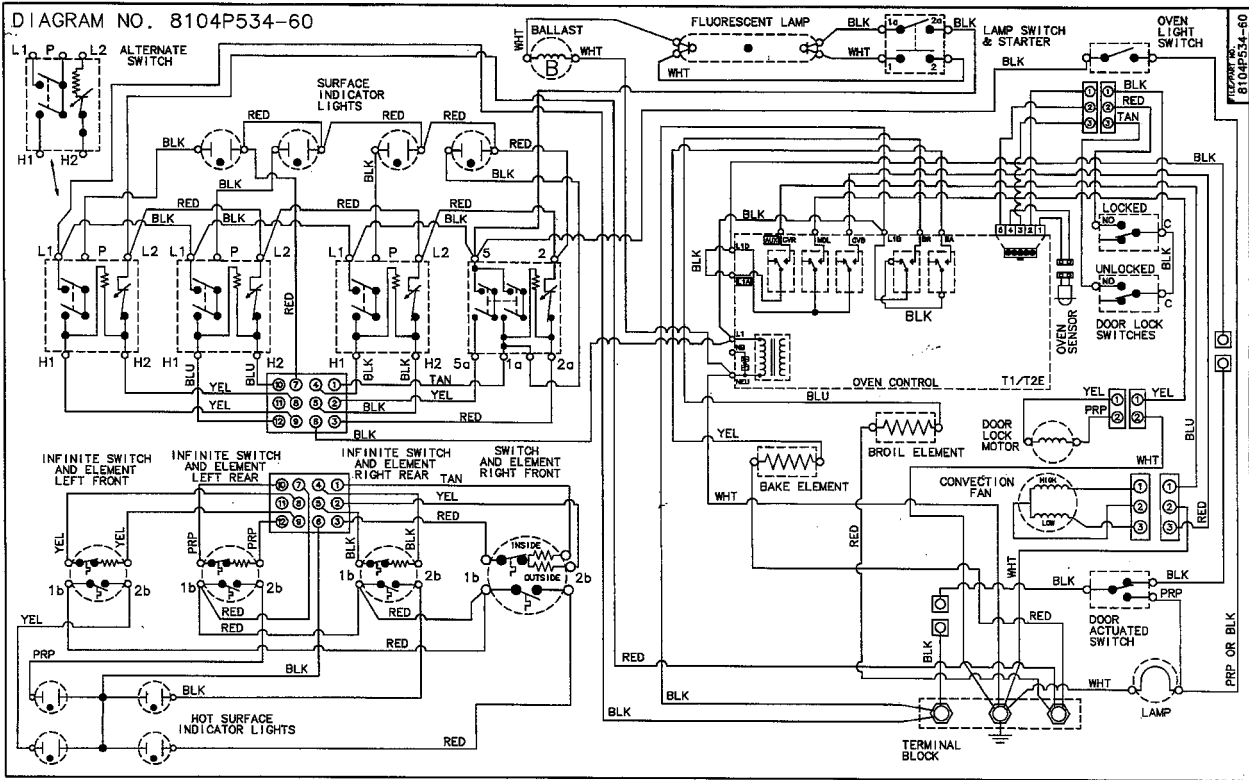

JER8850ACB JER8850ACW

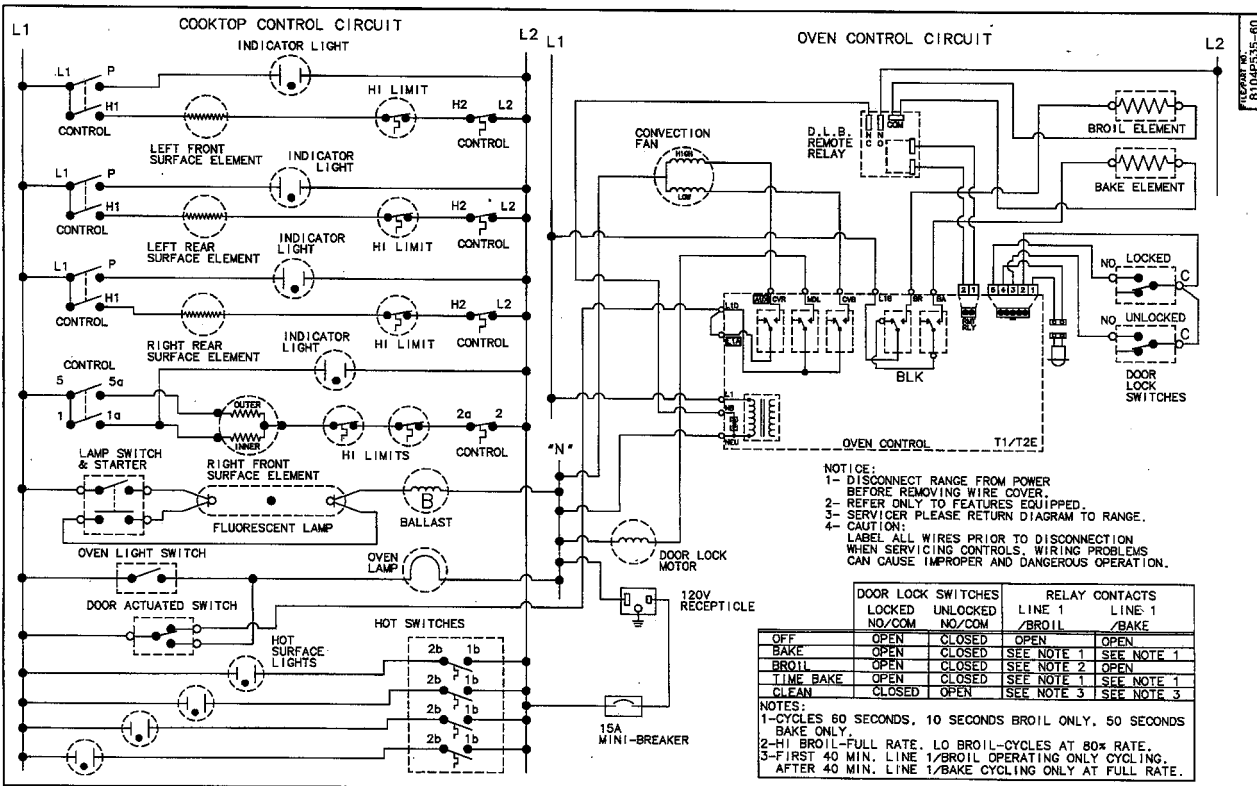
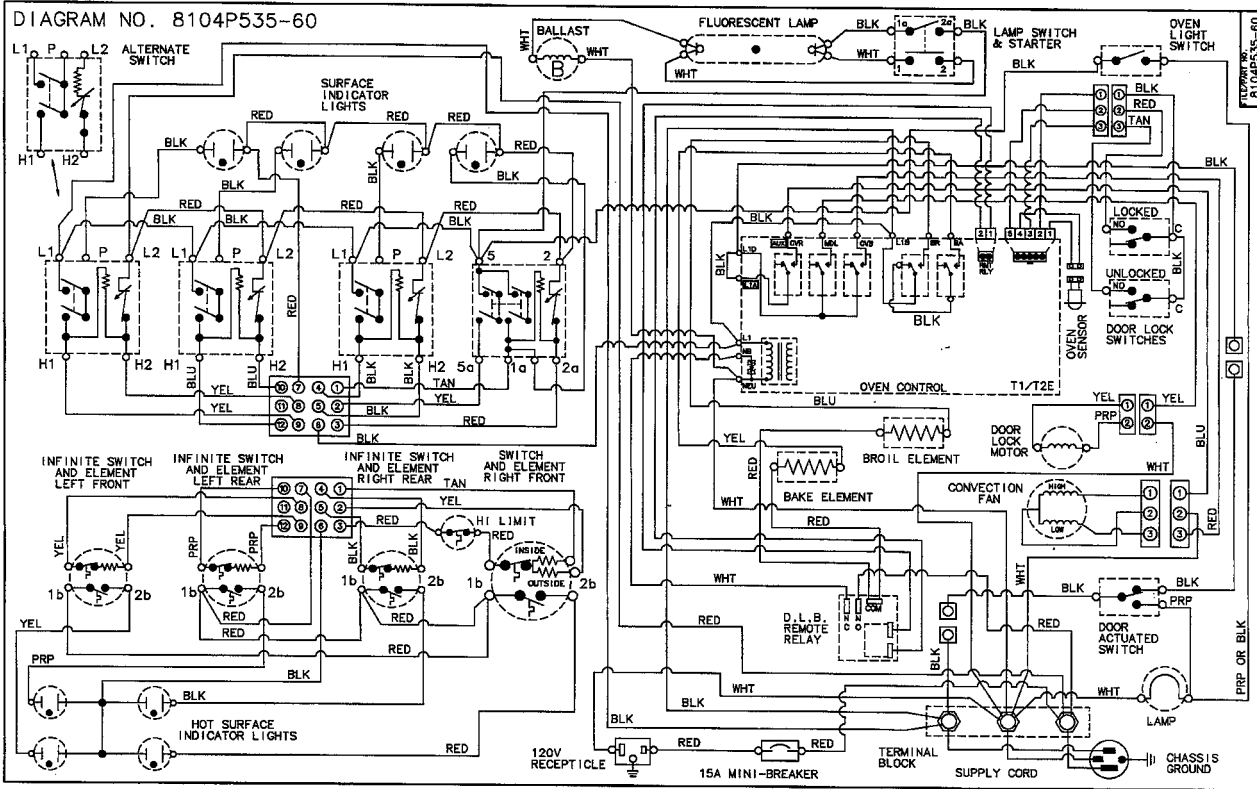

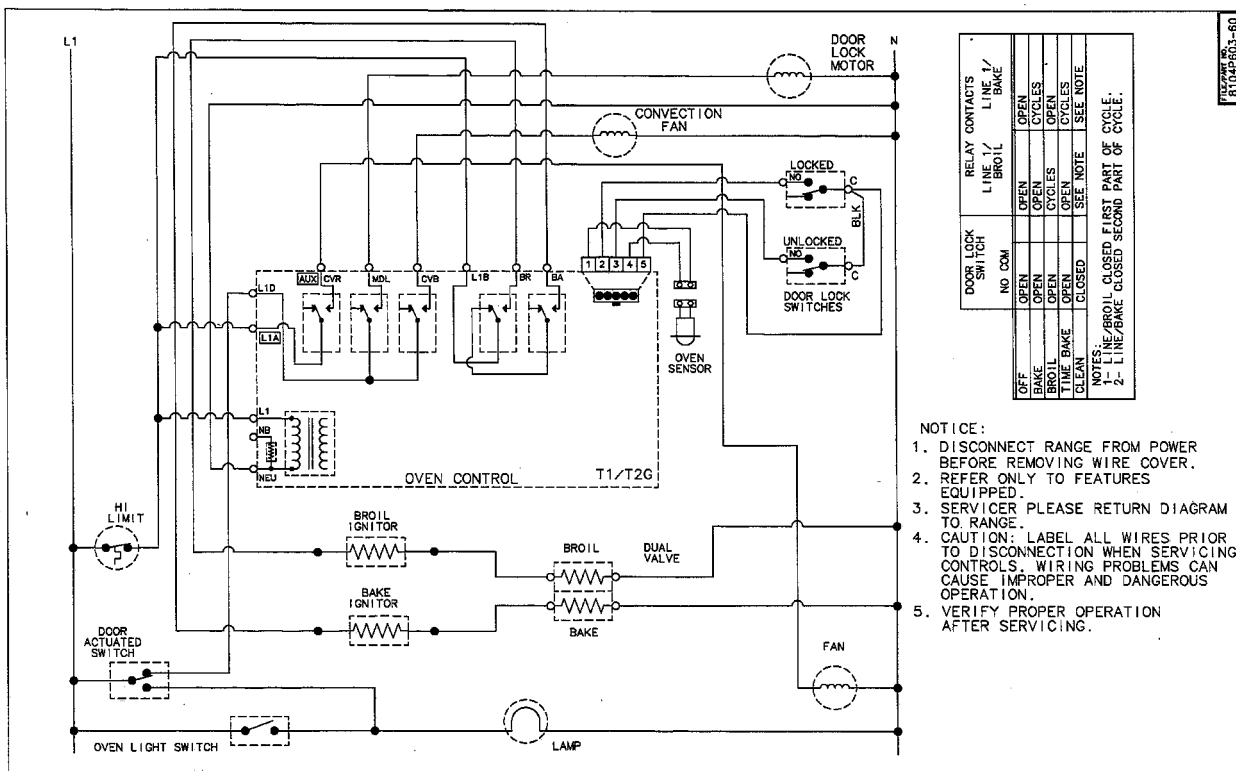
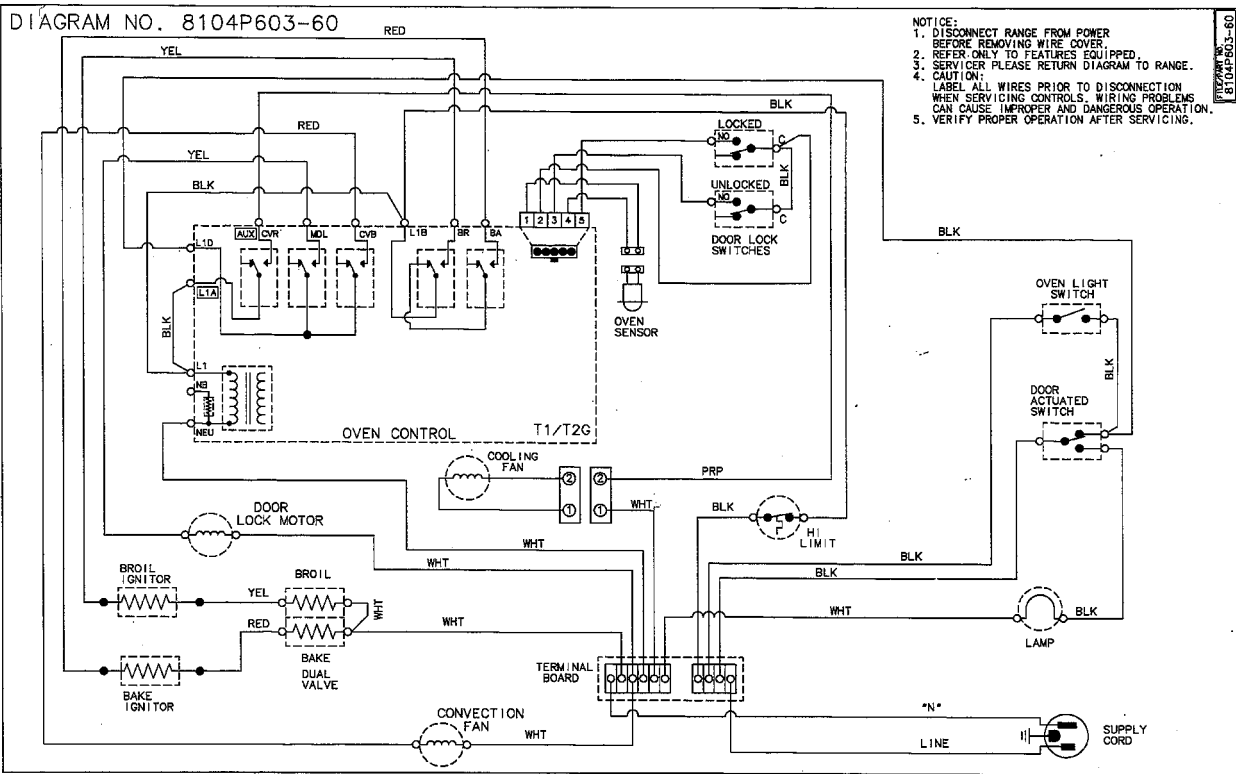

W132B W132W

DIAGRAM NO.
8104P600-60

- NOTICE:**
1. DISCONNECT RANGE FROM POWER BEFORE REMOVING WIRE COVER.
 2. REFER ONLY TO FEATURES EQUIPPED.
 3. SERVICER PLEASE RETURN DIAGRAM TO RANGE.
 4. CAUTION: LABEL ALL WIRES PRIOR TO DISCONNECTION WHEN SERVICING CONTROLS. WIRING PROBLEMS CAN CAUSE IMPROPER AND DANGEROUS OPERATION.
 5. VERIFY PROPER OPERATION AFTER SERVICING.

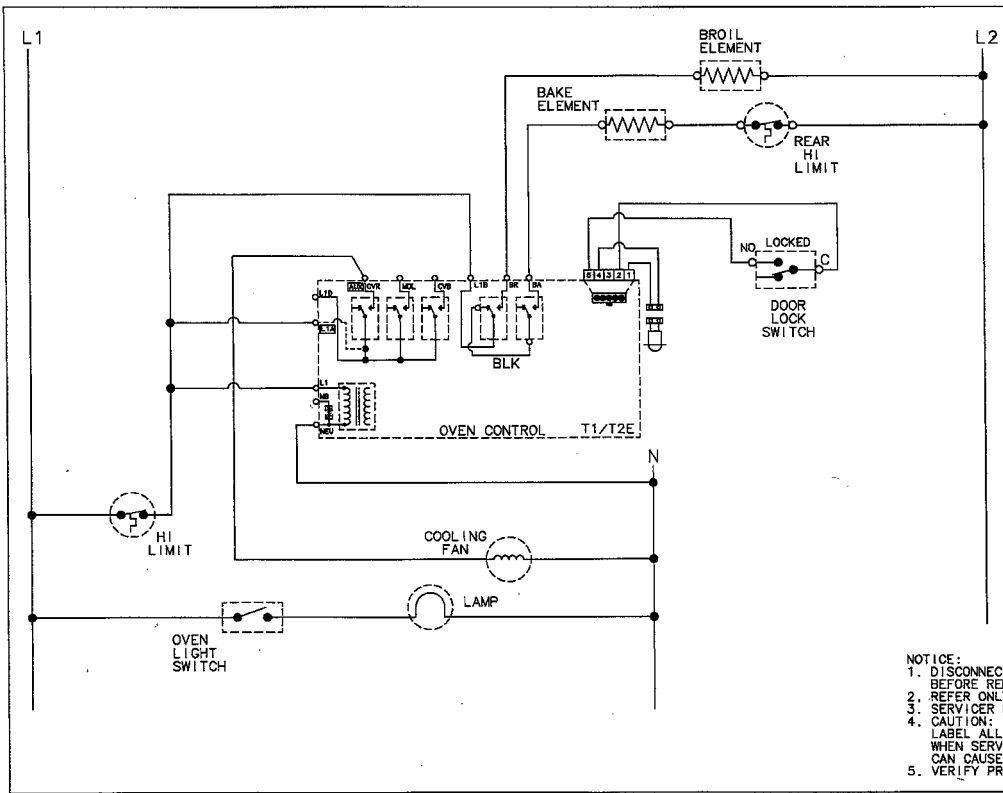
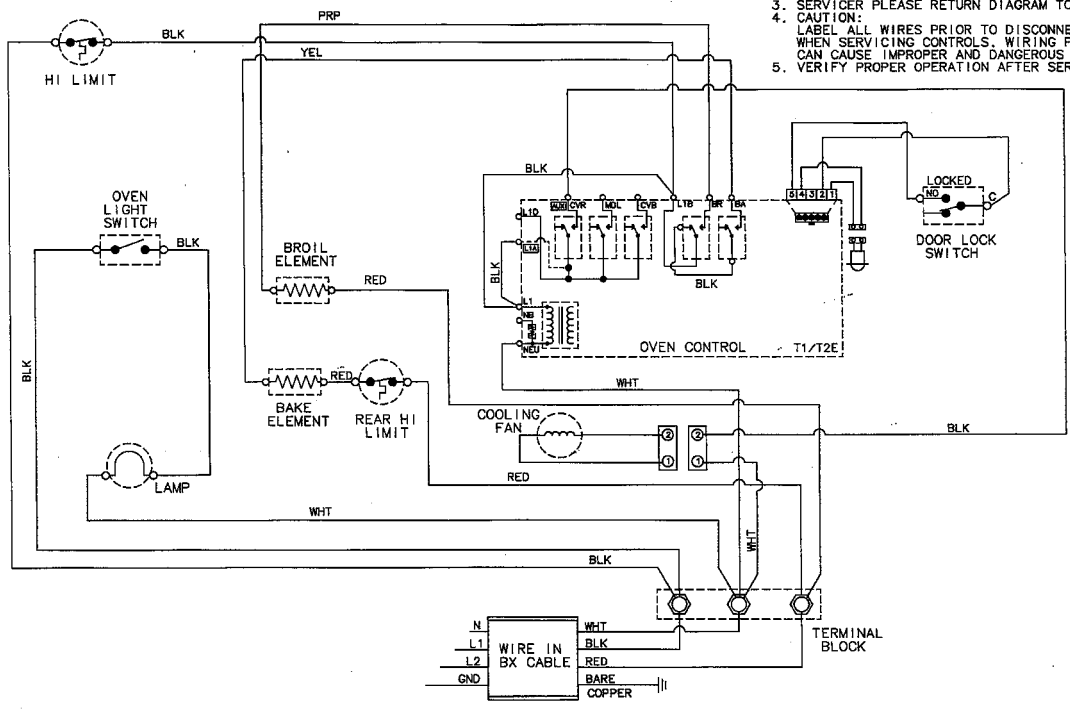

DOOR LOCK SWITCHES	RELAY CONTACTS	
	LINE 1	LINE 2
LOCKED	NO/COMMON	LINE 1
UNLOCKED	CLOSED	LINE 2
NO/COMMON	NO/COMMON	LINE 1
CLOSED	NO/COMMON	LINE 2
OPEN	CLOSED	LINE 1
BROIL	NO/COMMON	LINE 1
CLEAN	NO/COMMON	LINE 1
TIME BAKE	NO/COMMON	LINE 1
CLOSED	NO/COMMON	LINE 1
OPEN	NO/COMMON	LINE 1
NO/COMMON	NO/COMMON	LINE 1
CLOSED	NO/COMMON	LINE 1
OPEN	NO/COMMON	LINE 1

NOTES:
 1-CYCLES 80 SECONDS, 6 SECONDS BROIL ONLY, 54 SECONDS CLEAN ONLY.
 2-HI BROIL-FULL RATE, LO BROIL-CYCLES AT 80% RATE.
 3-FIRST 40 MIN. LINE 1/BROIL OPERATING ONLY CYCLING, AFTER 40 MIN. LINE 1/BAKE CYCLING ONLY AT FULL RATE.

- NOTICE:**
1. DISCONNECT RANGE FROM POWER BEFORE REMOVING WIRE COVER.
 2. REFER ONLY TO FEATURES EQUIPPED.
 3. SERVICER PLEASE RETURN DIAGRAM TO RANGE.
 4. CAUTION: LABEL ALL WIRES PRIOR TO DISCONNECTION WHEN SERVICING CONTROLS. WIRING PROBLEMS CAN CAUSE IMPROPER AND DANGEROUS OPERATION.
 5. VERIFY PROPER OPERATION AFTER SERVICING.

Magic Chef Models:

CGR1320BDH CGR1320BDW CGR1330BDC CGR1330BDH

CGR1330BDT CGR1420BDQ CGR1420BDW CGR1430BDH CGR1430BDT

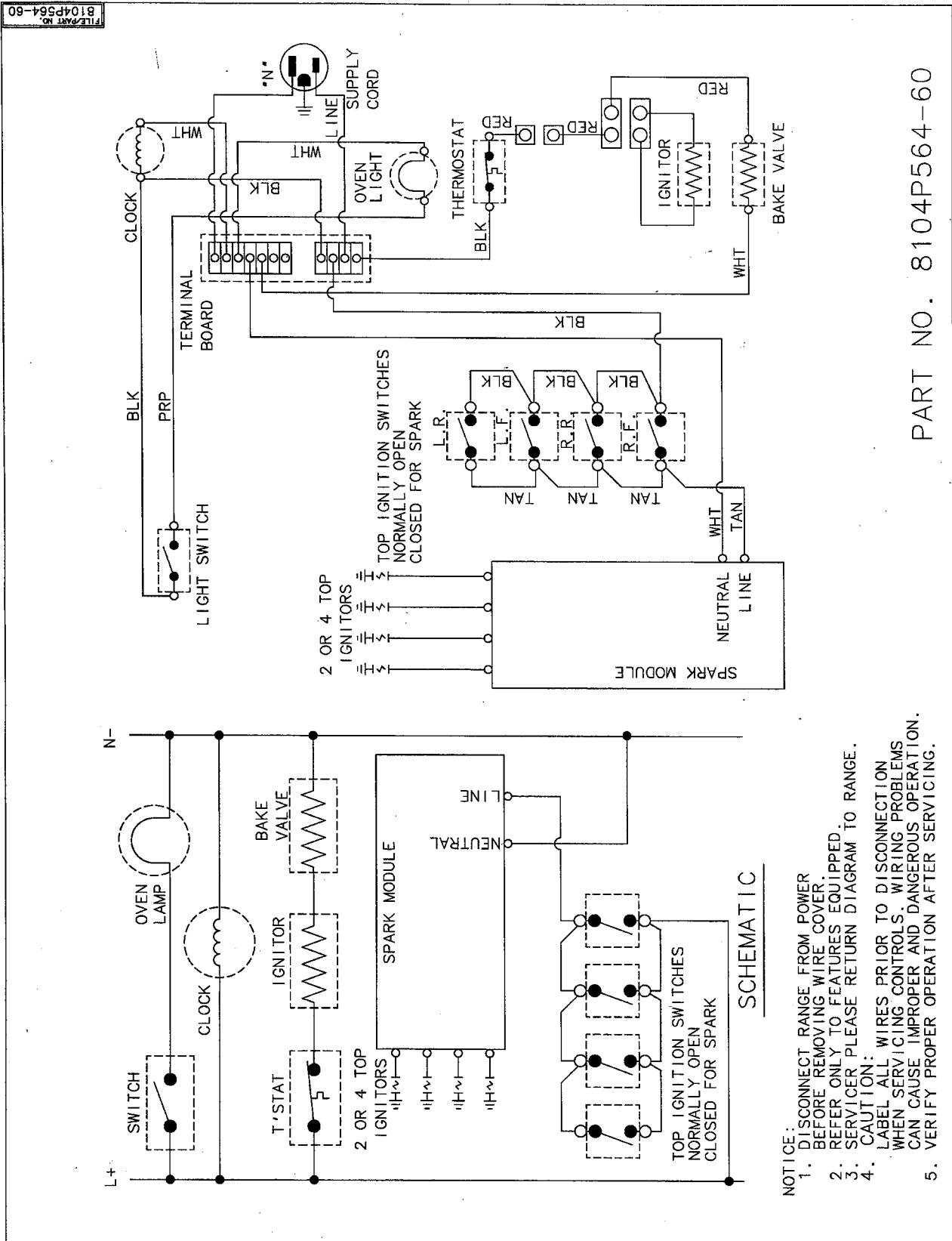

PART NO. 8104P564-60

CGR3520BDH CGR3520BDT

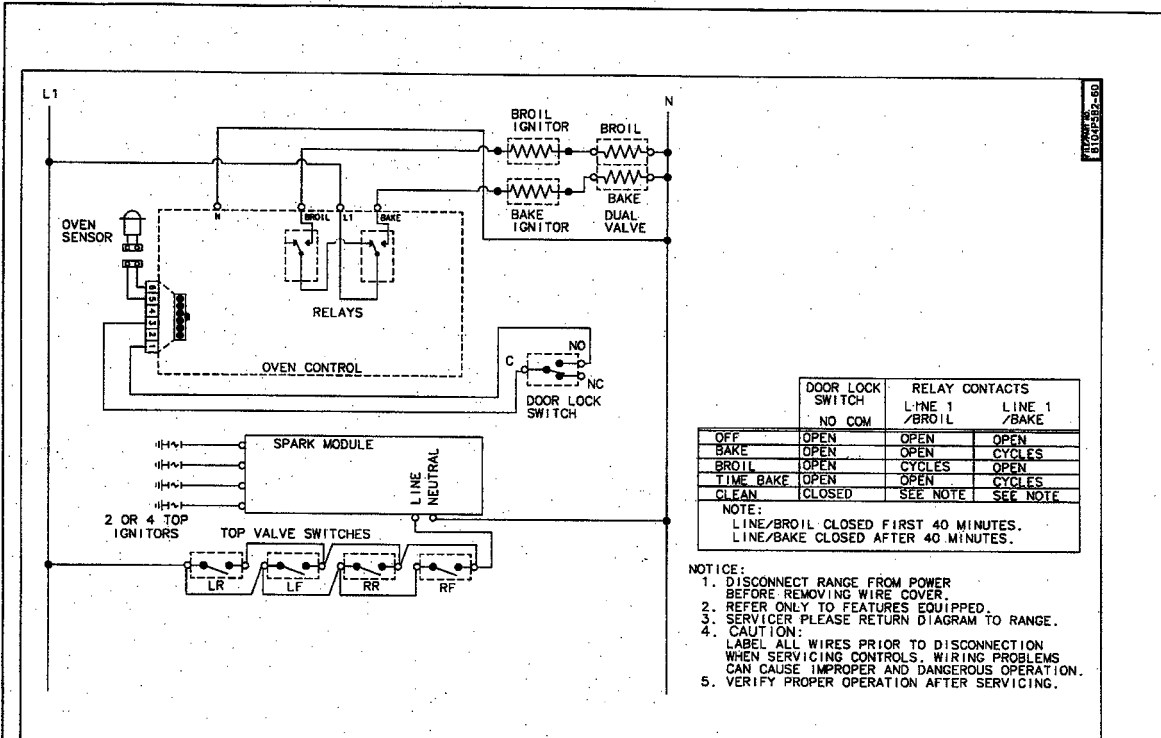

2 PER (8X5)
PART NO. IN UPPER LEFT CORNER PAGE 1

SEE SHEET #1 FOR CURRENT REVISIONS. DIAGRAM. 8104P582-60 2 OF 2

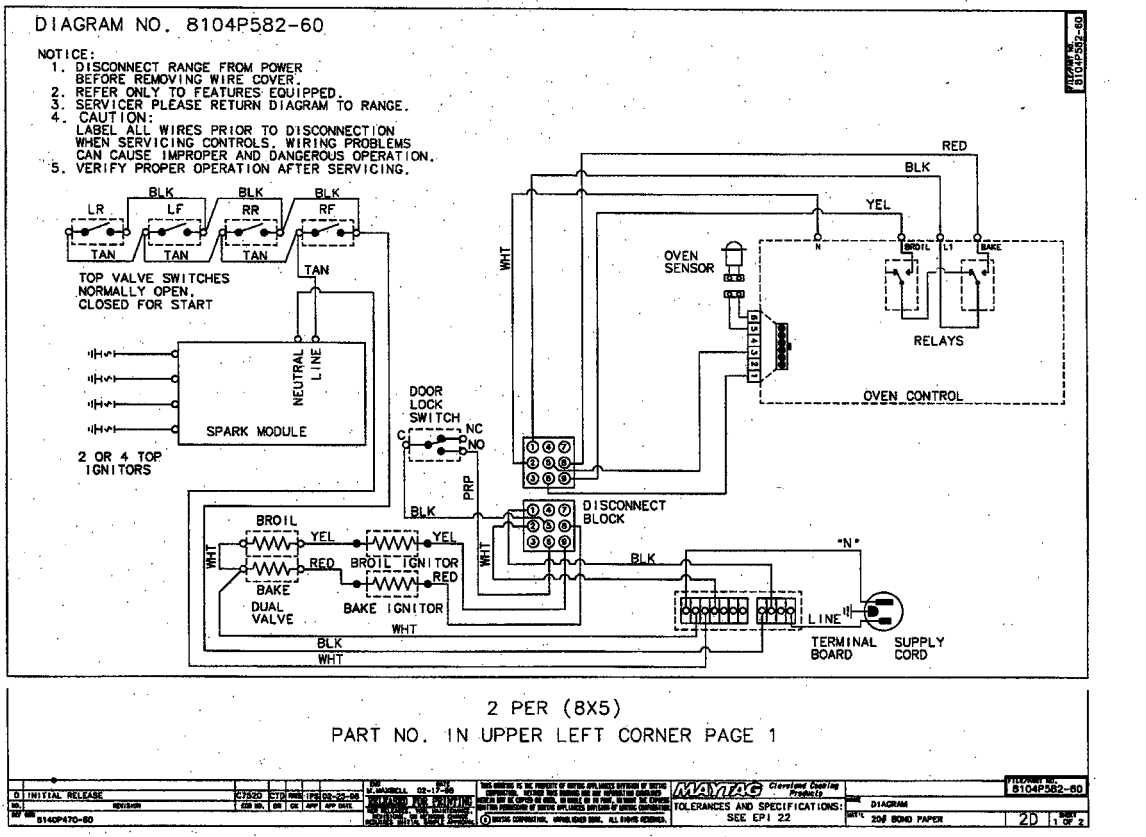

2 PER (8X5)
PART NO. IN UPPER LEFT CORNER PAGE 1

INITIAL RELEASE. 8104P582-60 2 OF 2

**CGR3740BDH CGR3740BDT CGR3740BDW CGR3742BDC CGR3742BDQ
CGR3742BDW**

DIAGRAM NO. 8104P583-60

DIAGRAM NO. 8104P583-60

NOTICE:

1. DISCONNECT RANGE FROM POWER BEFORE REMOVING WIRE COVER.
2. REFER ONLY TO FEATURES EQUIPPED.
3. SERVICER PLEASE RETURN DIAGRAM TO RANGE.
4. CAUTION:
LABEL ALL WIRES PRIOR TO DISCONNECTION WHEN SERVICING CONTROLS. WIRING PROBLEMS CAN CAUSE IMPROPER AND DANGEROUS OPERATION.
5. VERIFY PROPER OPERATION AFTER SERVICING.

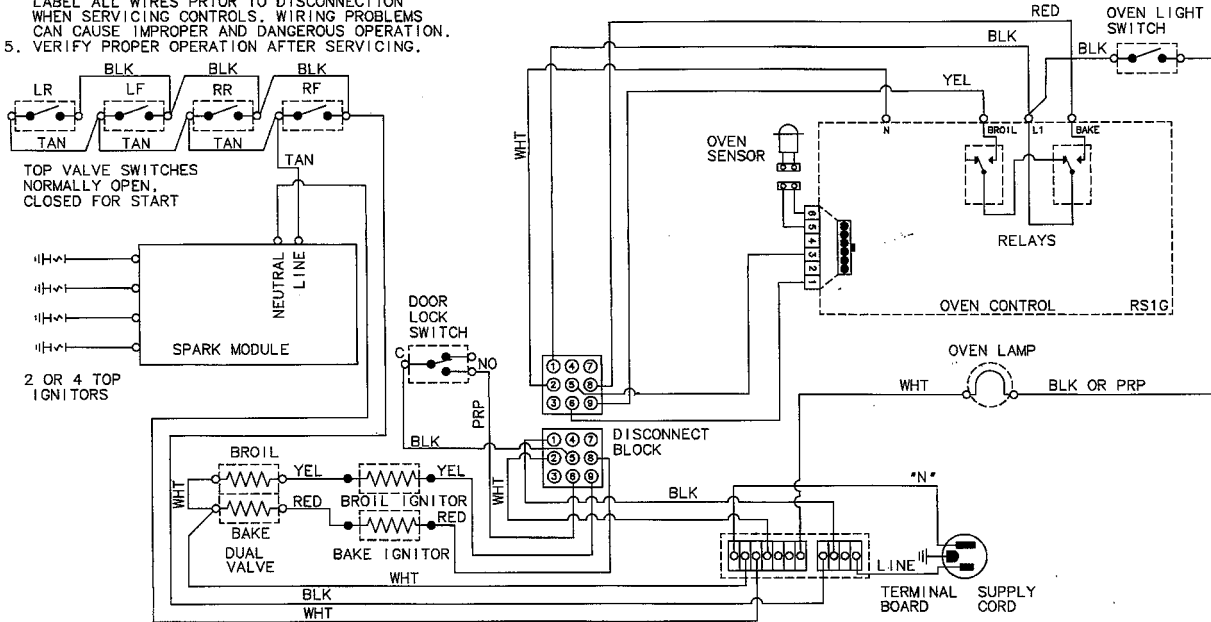
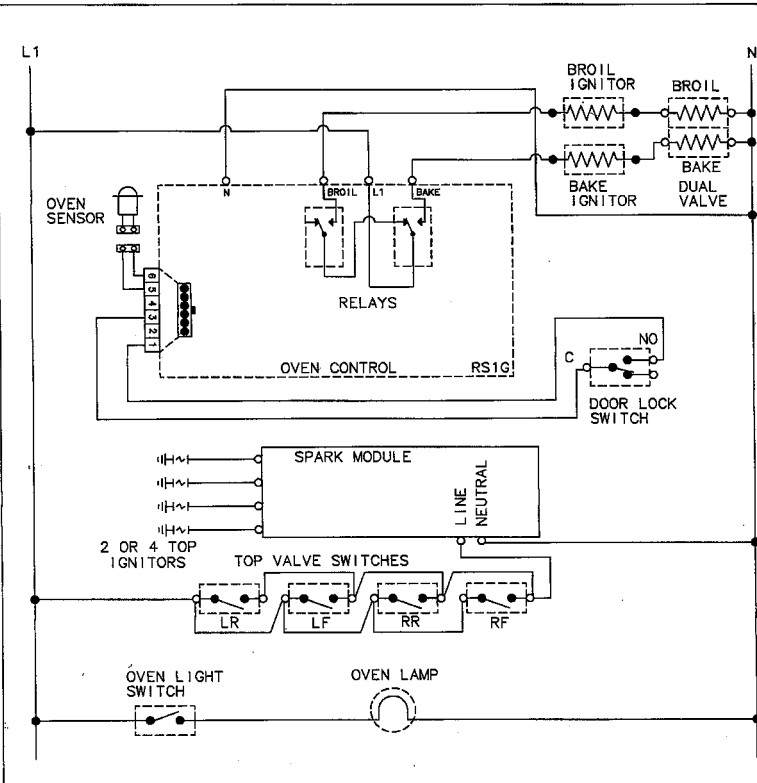

DIAGRAM NO. 8104P583-60



	DOOR LOCK SWITCH NO COM	RELAY CONTACTS	
		LINE 1 / BROIL	LINE 1 / BAKE
OFF	OPEN	OPEN	OPEN
BAKE	OPEN	OPEN	CYCLES
BROIL	OPEN	CYCLES	OPEN
TIME BAKE	OPEN	OPEN	CYCLES
CLEAN	CLOSED	SEE NOTE	SEE NOTE

NOTE:
LINE/BROIL CLOSED FIRST 40 MINUTES.
LINE/BAKE CLOSED AFTER 40 MINUTES.

- NOTICE:**
1. DISCONNECT RANGE FROM POWER BEFORE REMOVING WIRE COVER.
 2. REFER ONLY TO FEATURES EQUIPPED.
 3. SERVICER PLEASE RETURN DIAGRAM TO RANGE.
 4. CAUTION:
LABEL ALL WIRES PRIOR TO DISCONNECTION WHEN SERVICING CONTROLS. WIRING PROBLEMS CAN CAUSE IMPROPER AND DANGEROUS OPERATION.
 5. VERIFY PROPER OPERATION AFTER SERVICING.

CGR3760BDB CGR3760BDQ CGR3760BDW CGR3765BDC

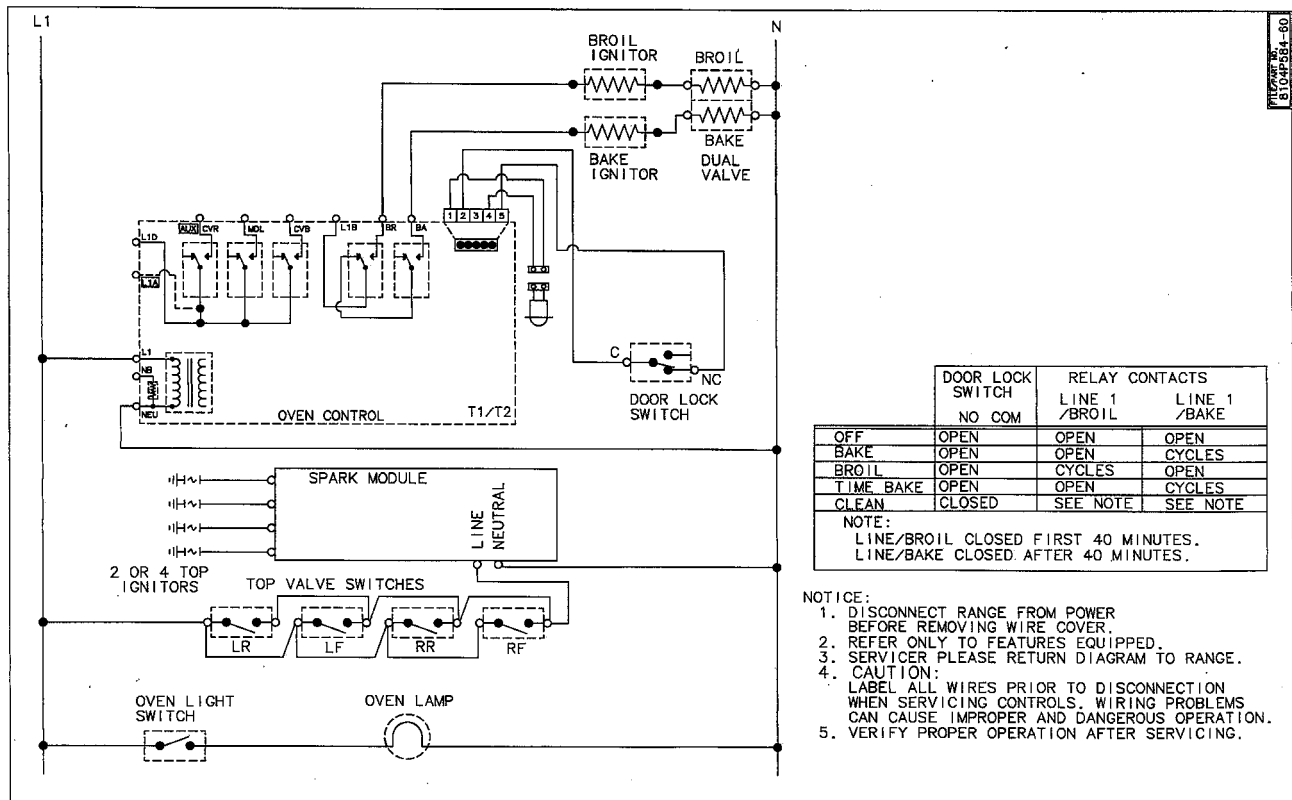
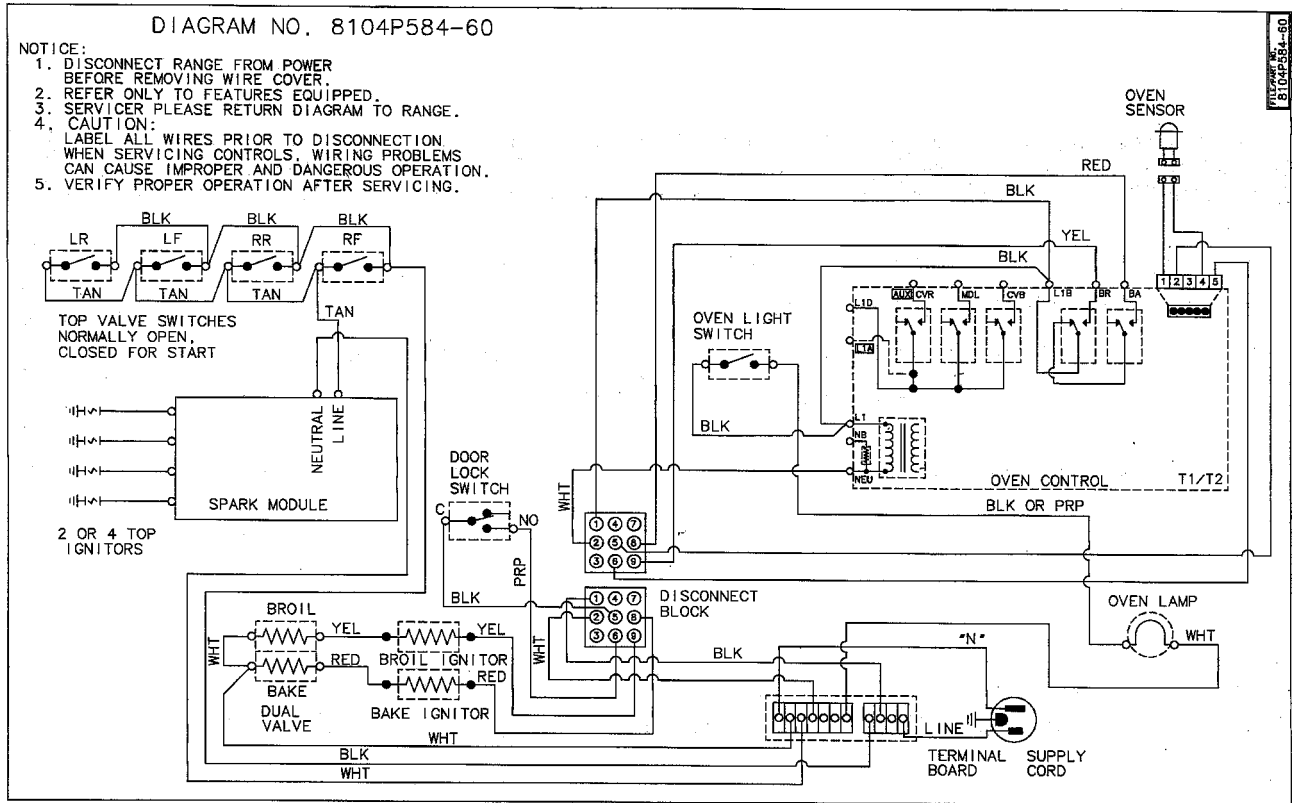



IMPORTANT

Wiring information in this manual was accurate at the time of manual production. Wiring information is subject to change at any time. Please refer to wiring information on the actual product for most current information.

*Because of the simple design of this appliance, wiring is minimal. No engineering diagrams are available. Please refer to information supplied with the unit.



IMPORTANT

Wiring information in this manual was accurate at the time of manual production. Wiring information is subject to change at any time. Please refer to wiring information on the actual product for most current information.

*Because of the simple design of this appliance, wiring is minimal. No engineering diagrams are available. Please refer to information supplied with the unit.

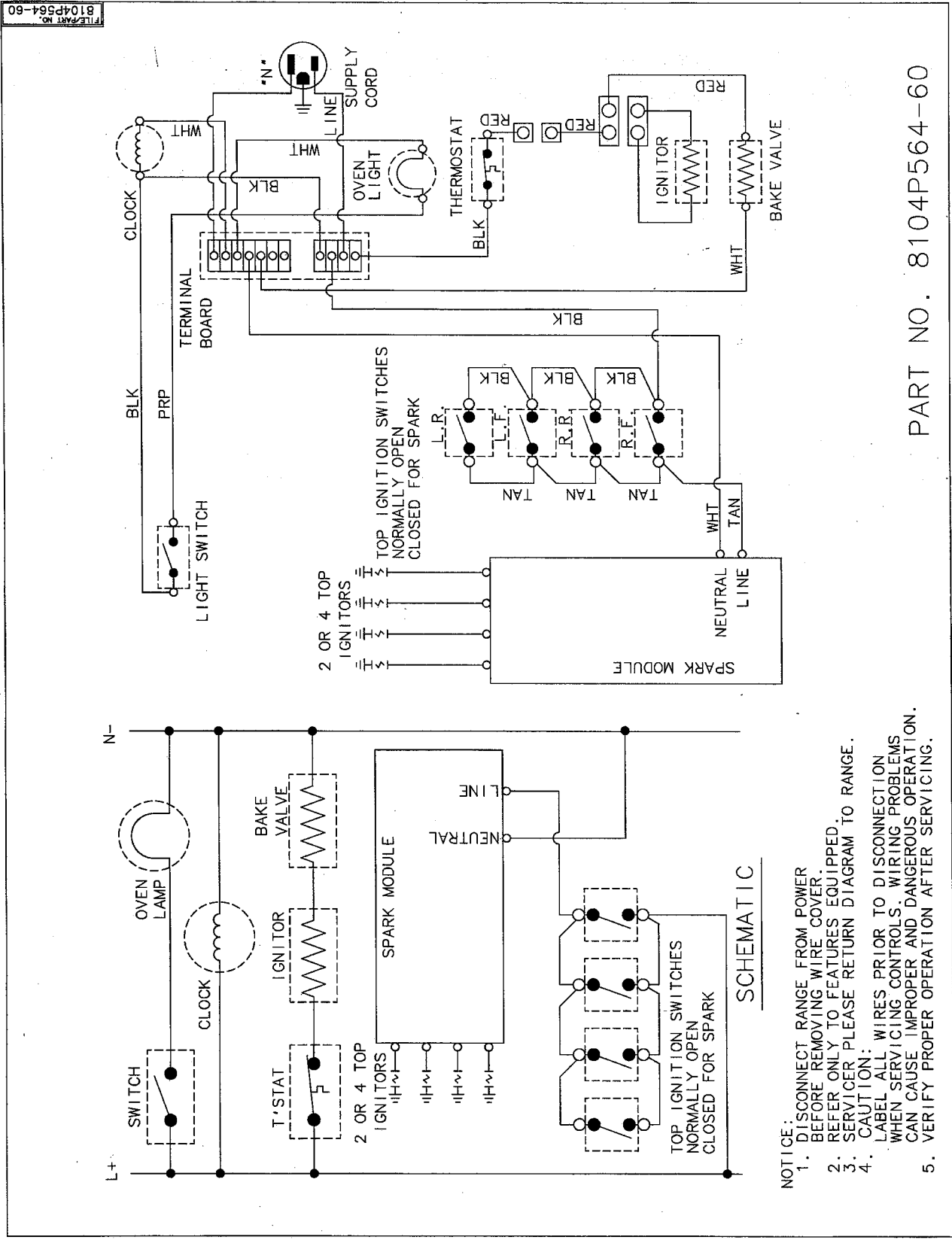

PART NO. 8104P564-60

CEP3540AAQ CEP3540AAW CES3540AAC CES3540AAW

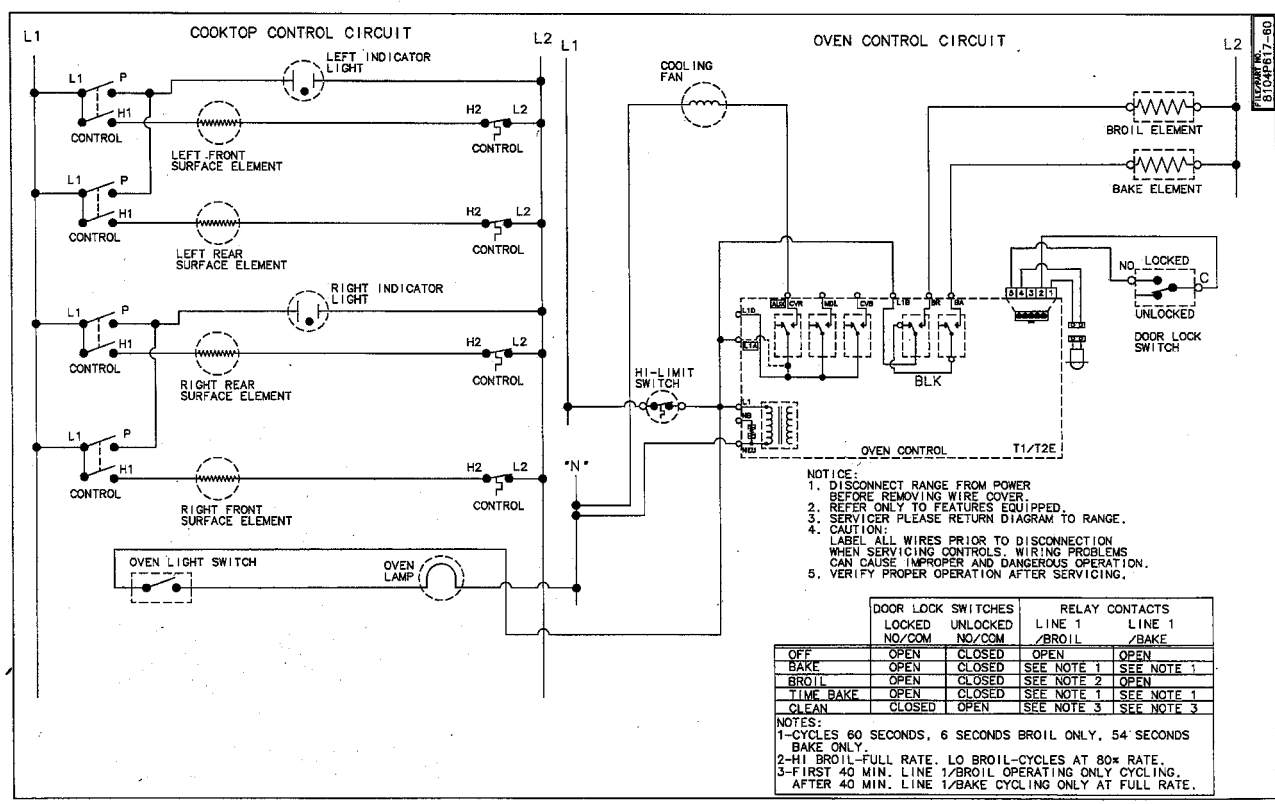
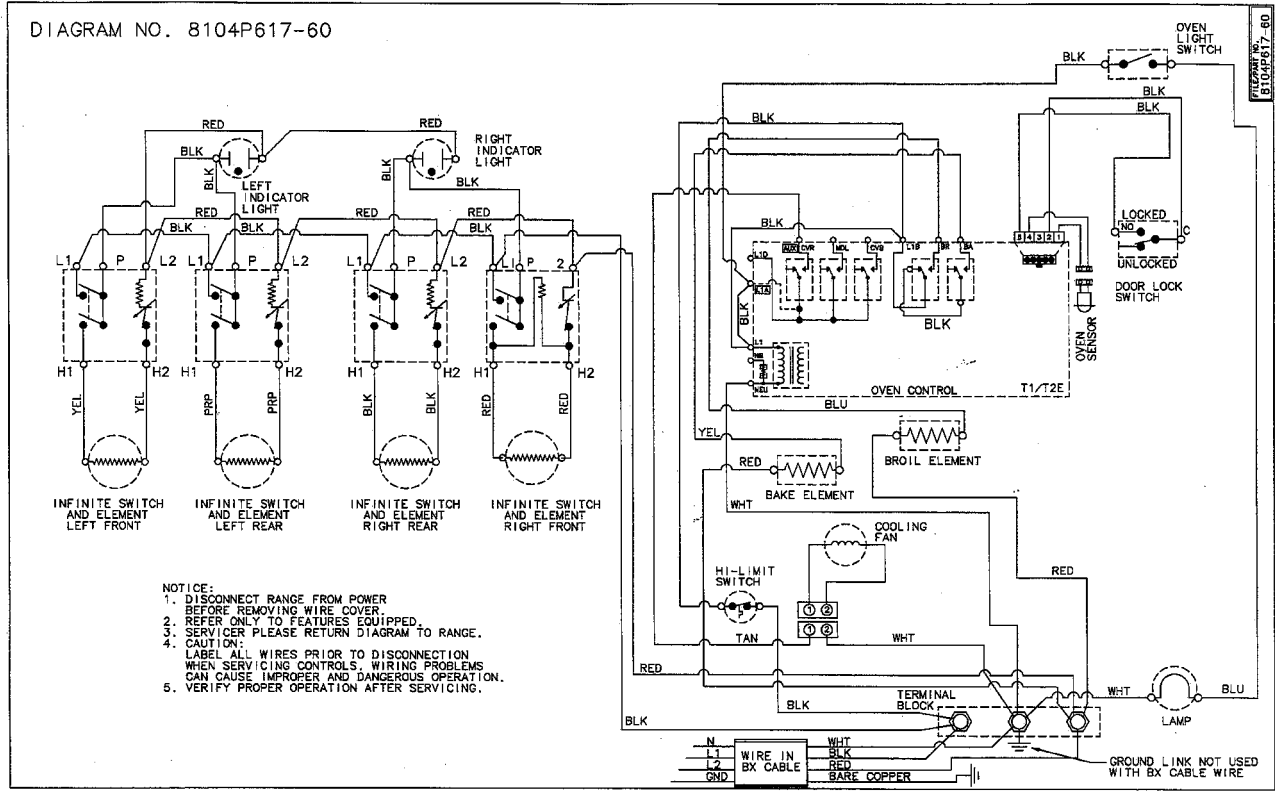

**CEP3760AAB CEP3760AAQ CEP3760AAW CES3760AAB CES3760AAQ
CES3760AAW**

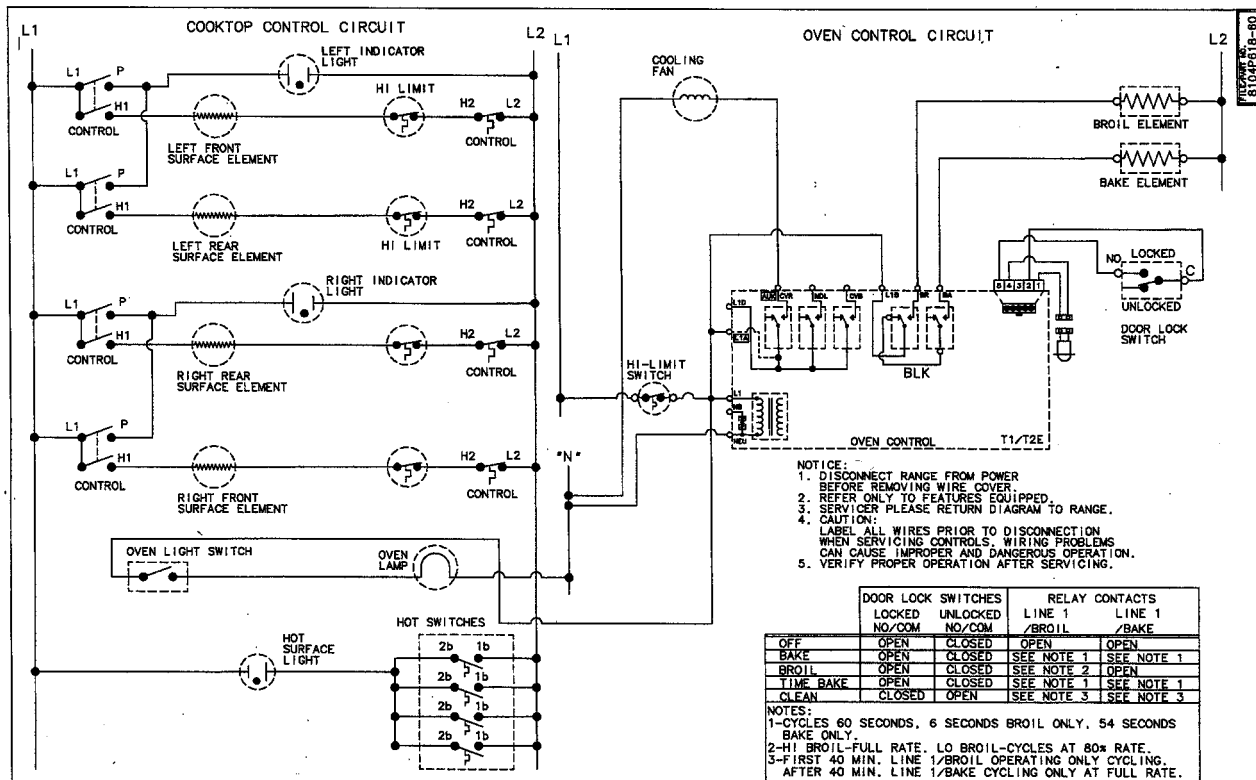
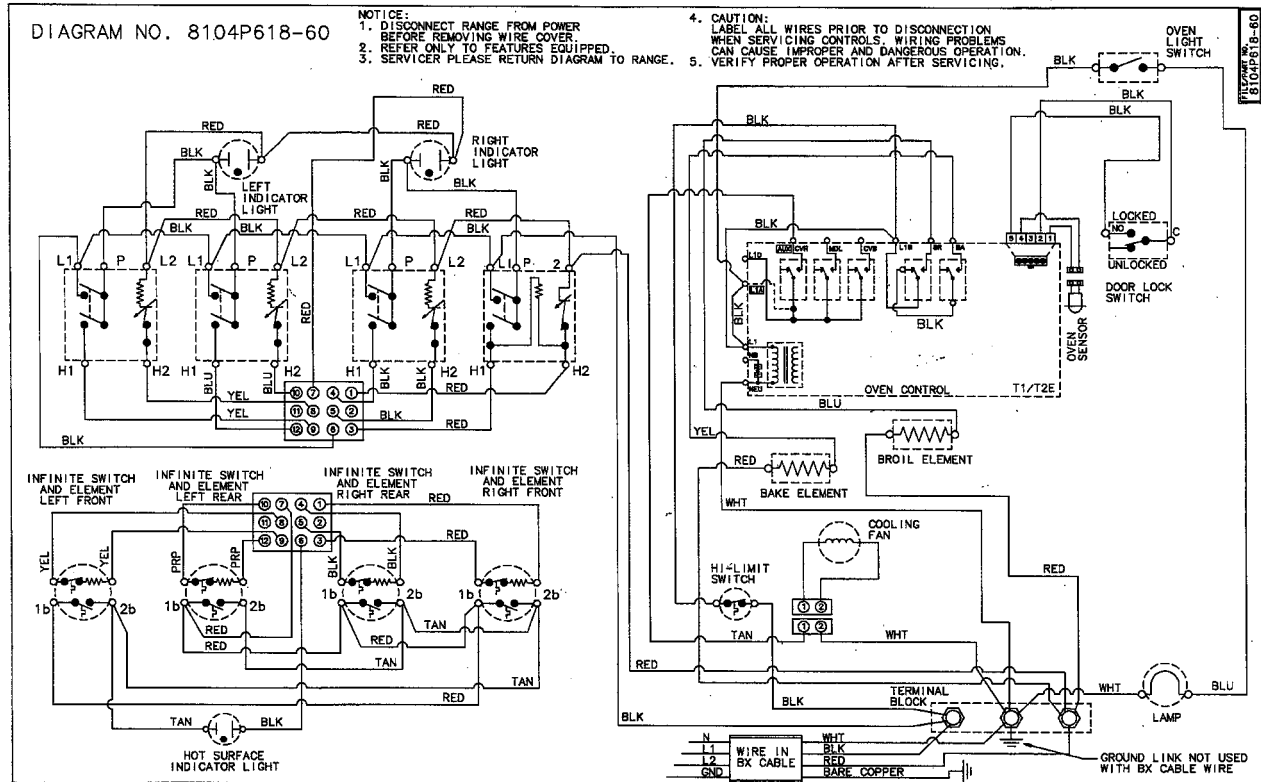

CER110AAH CER110AAT

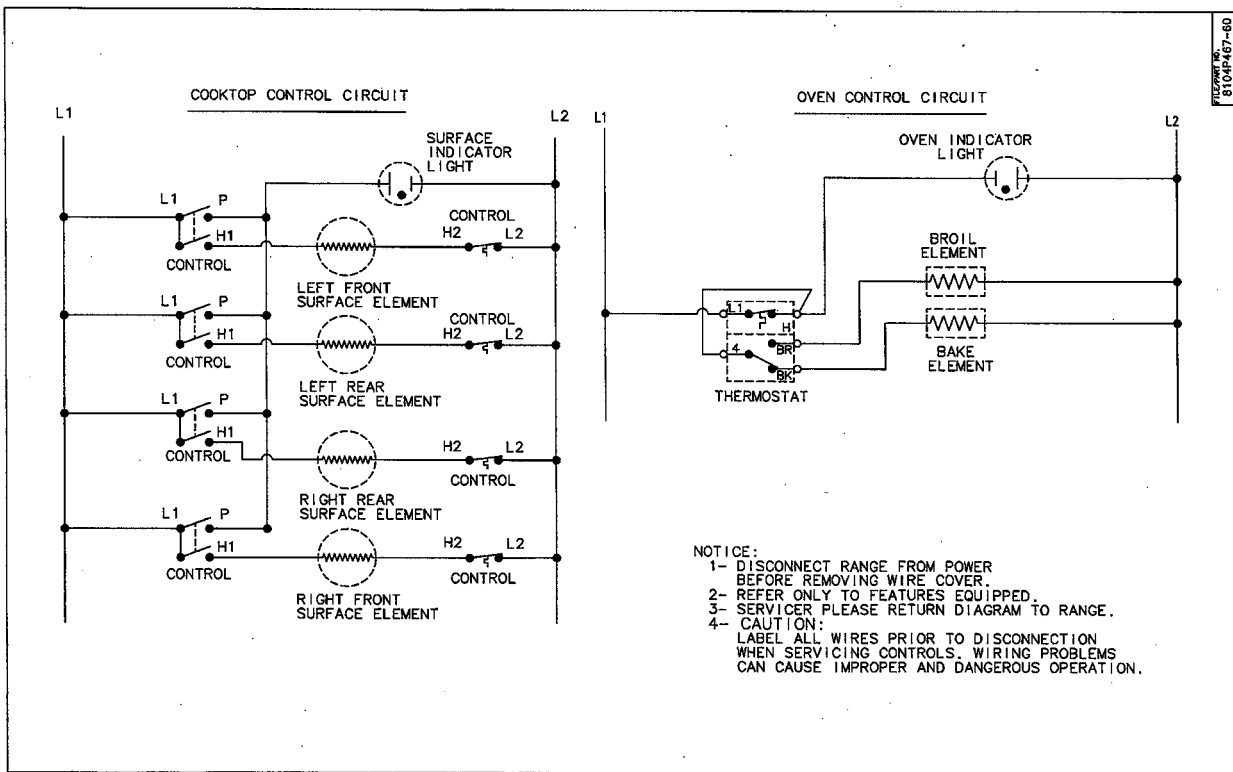
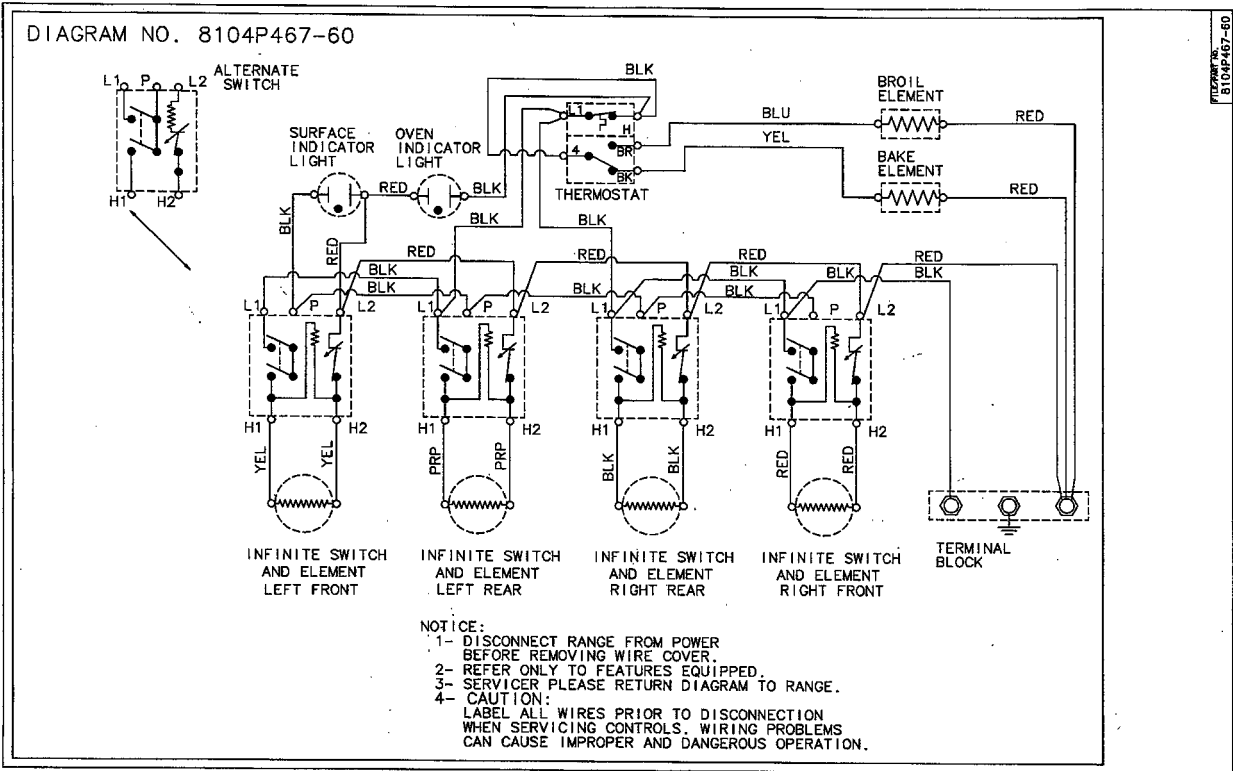

CER1140AAQ CER1140AW CER1160AAH CER1160AAT

DIAGRAM NO. 8104P552-60

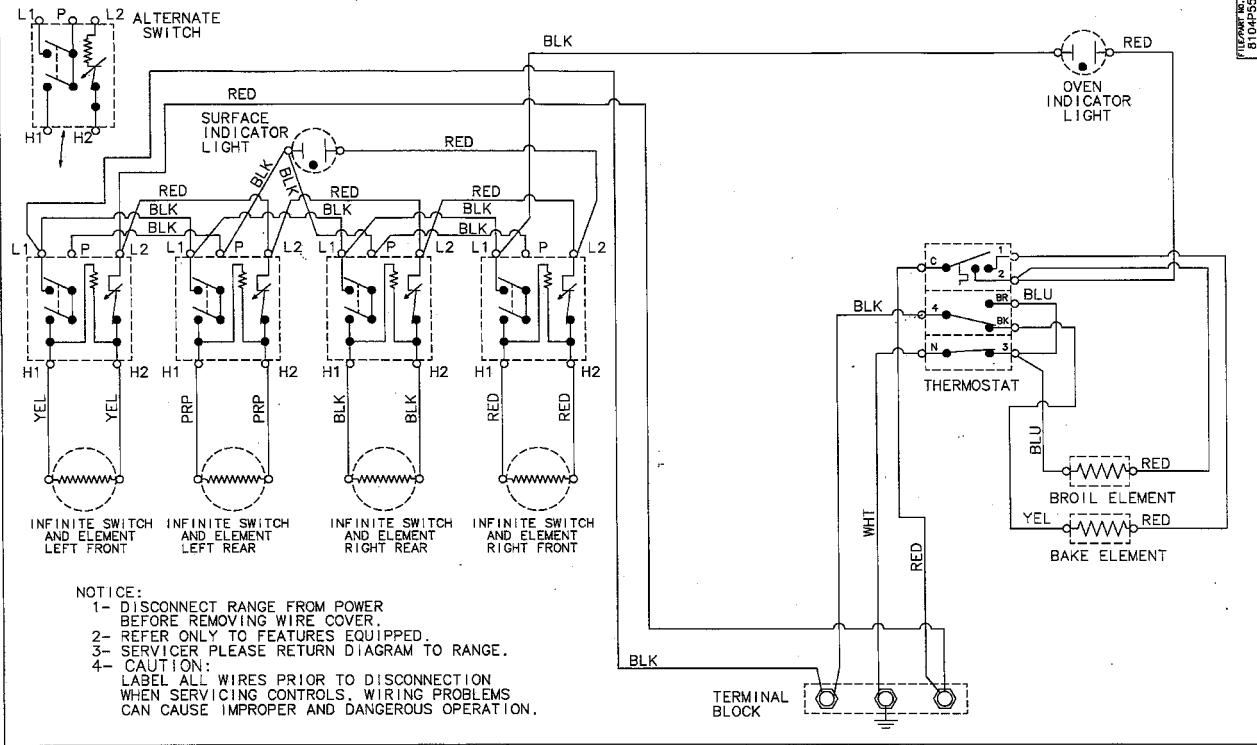

NOTICE:
 1- DISCONNECT RANGE FROM POWER BEFORE REMOVING WIRE COVER.
 2- REFER ONLY TO FEATURES EQUIPPED.
 3- SERVICER PLEASE RETURN DIAGRAM TO RANGE.
 4- CAUTION: LABEL ALL WIRES PRIOR TO DISCONNECTION WHEN SERVICING CONTROLS. WIRING PROBLEMS CAN CAUSE IMPROPER AND DANGEROUS OPERATION.

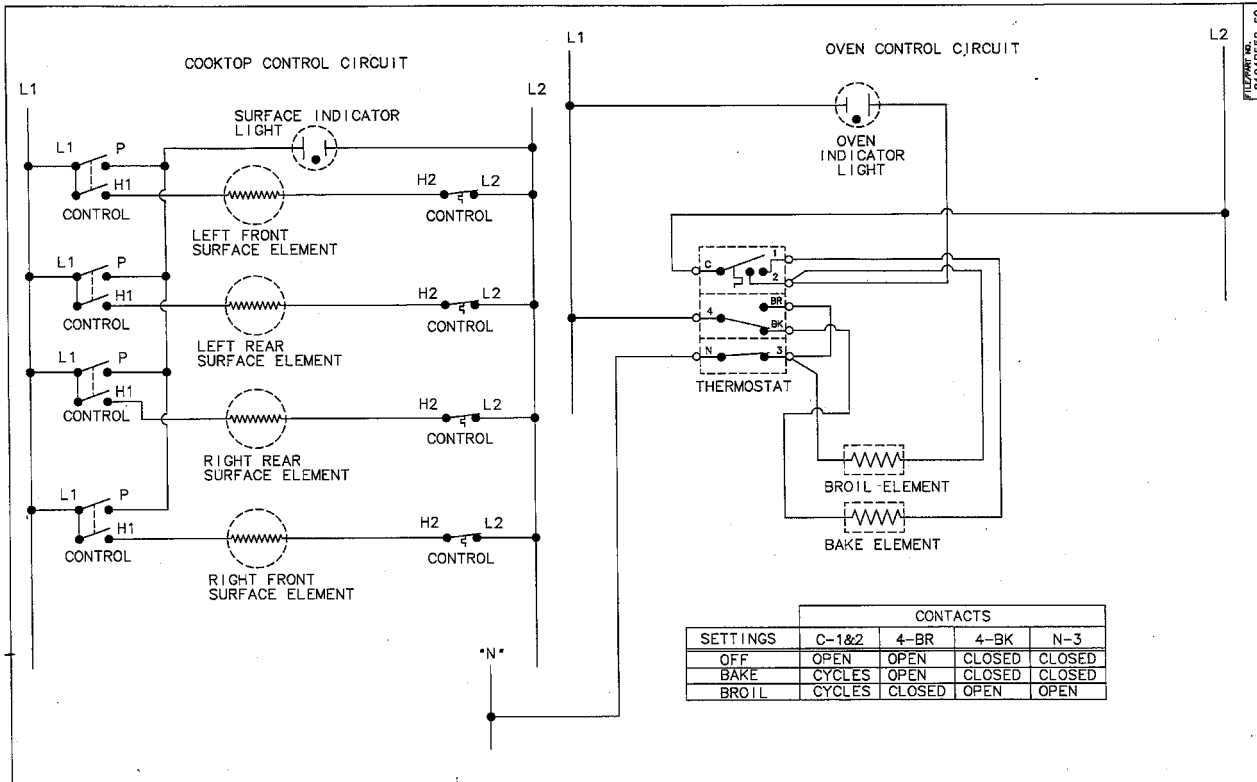

CER1360AAW

DIAGRAM NO. 8104P554-60

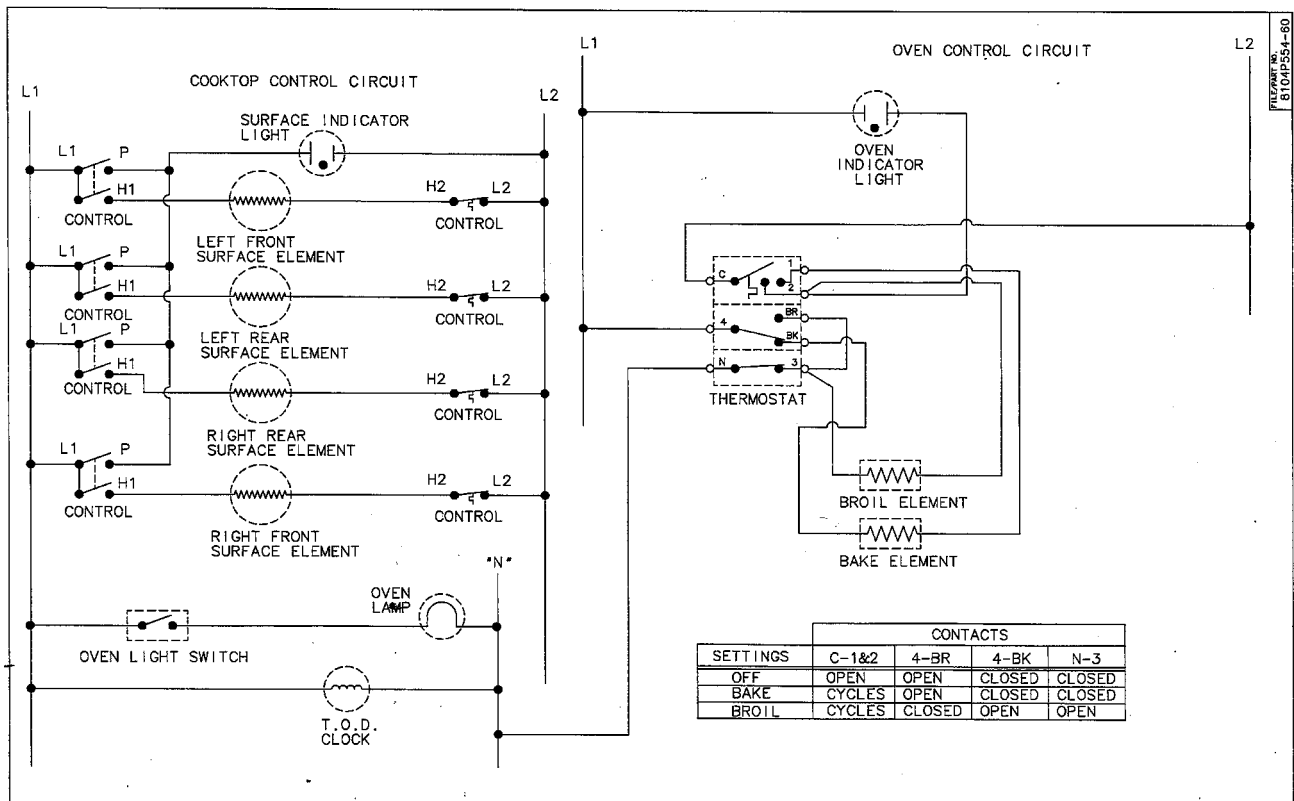
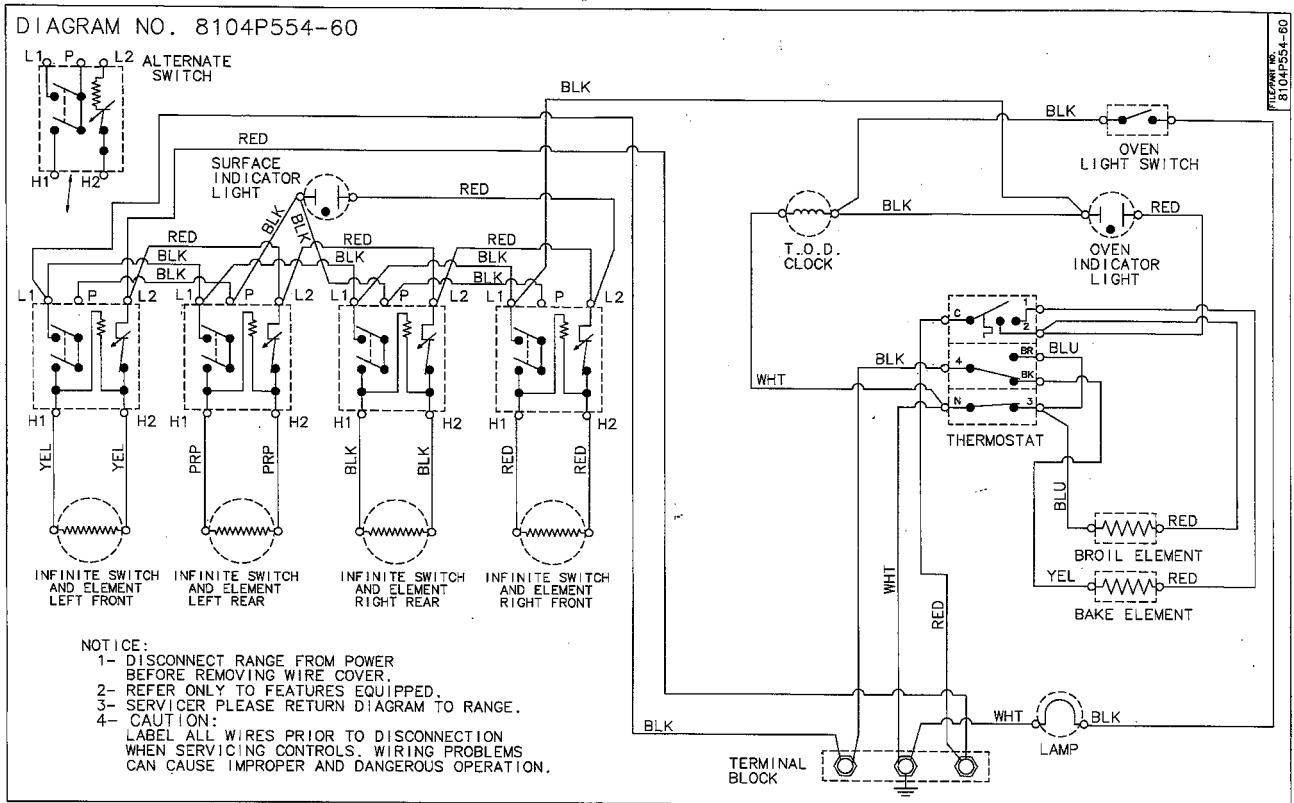

CER1360BCW

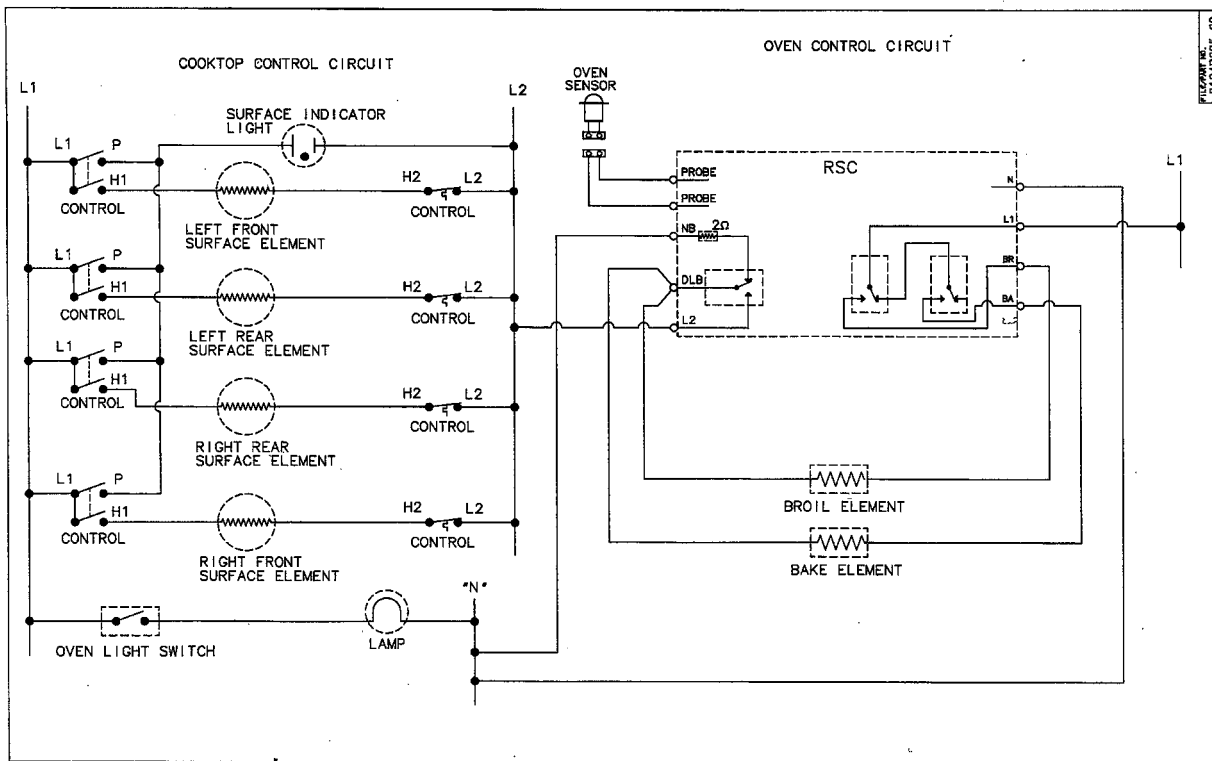
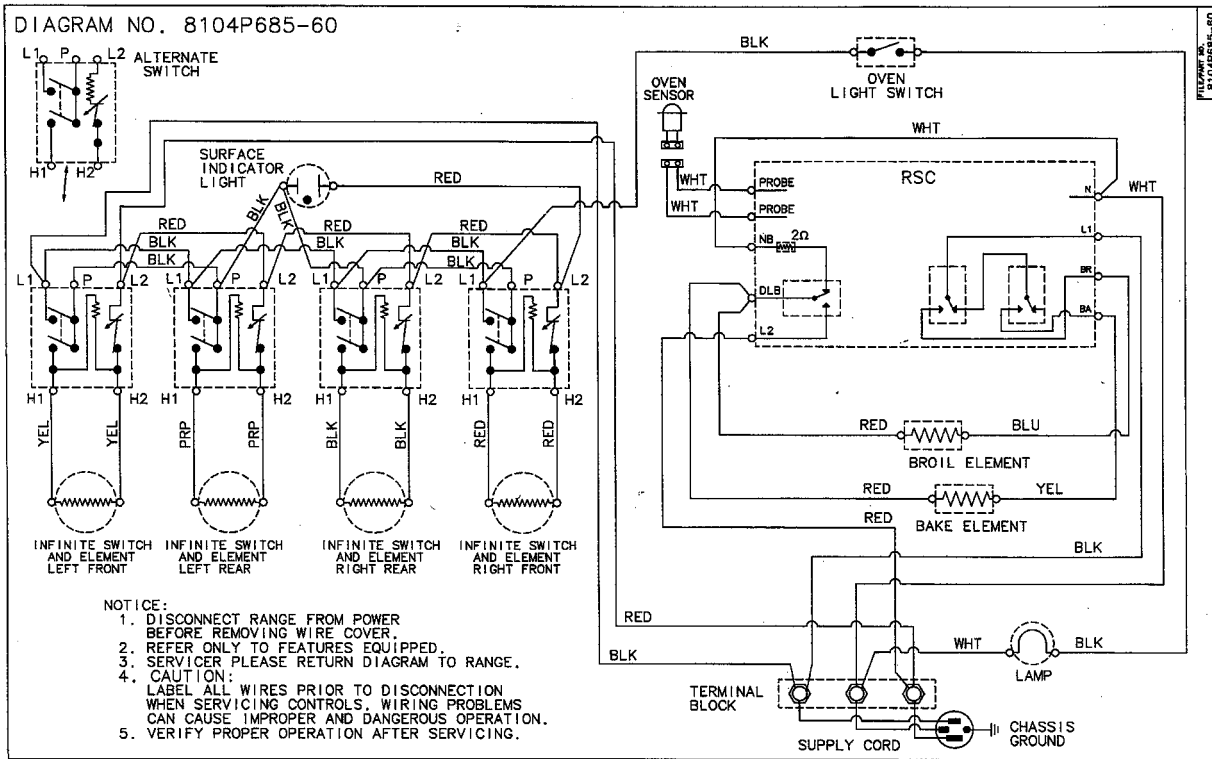

CER3520AAH CER3520AAT CER3540AAH CER3540AAQ CER3540AAT CER3540AAW

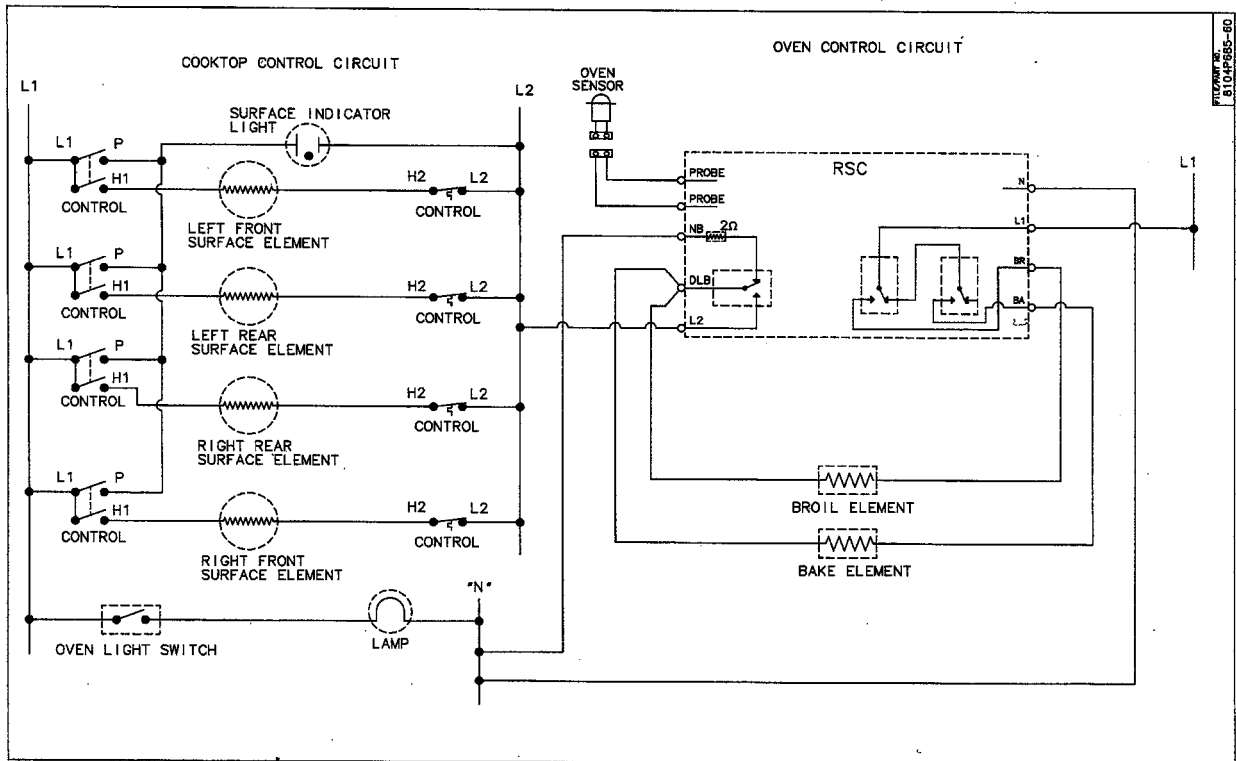
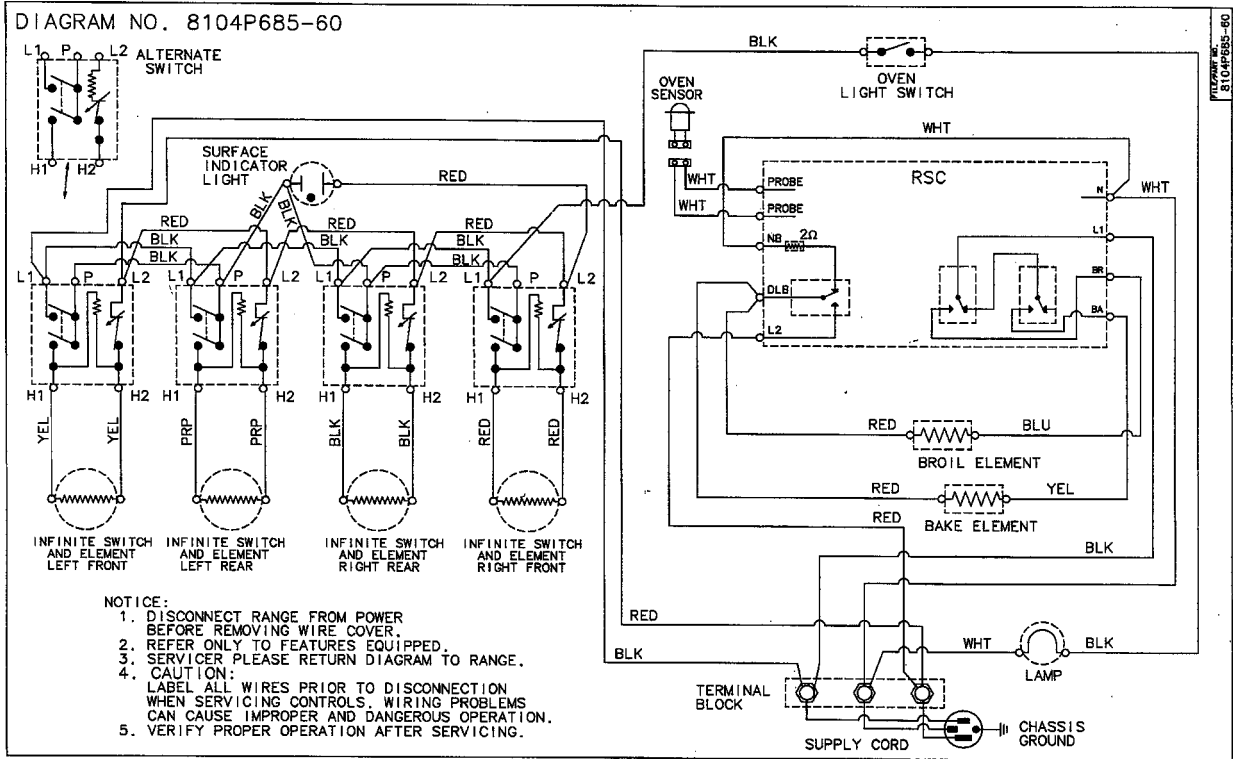

CER3540ACB CER3540ACW

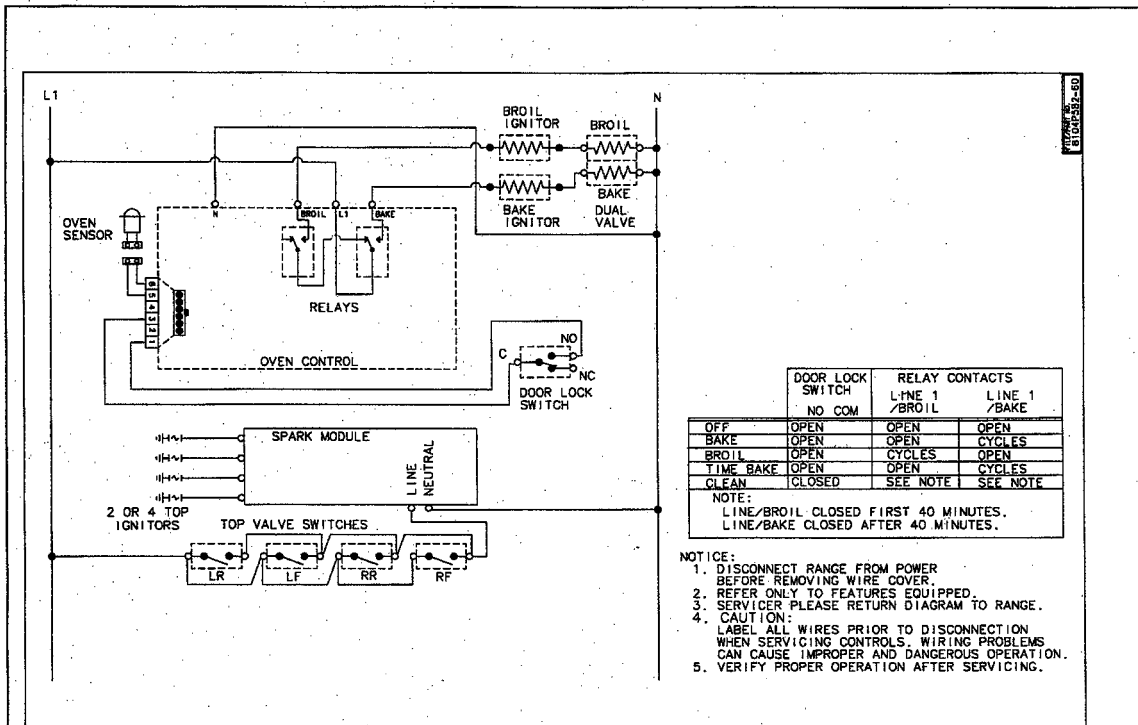

2 PER (8X5)
PART NO. IN UPPER LEFT CORNER PAGE 1

SEE SHEET #1 FOR CURRENT REVISIONS
DIAGRAM
PART NO. 8104P582-60 2 OF 2

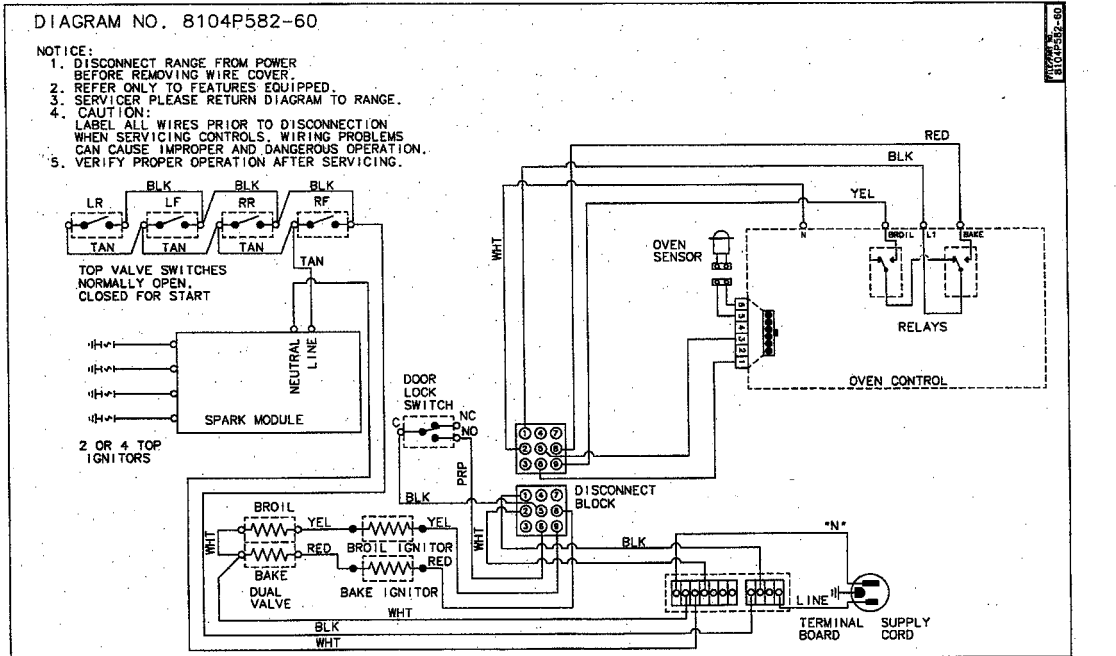

2 PER (8X5)
PART NO. IN UPPER LEFT CORNER PAGE 1

INITIAL RELEASE
REVISION
PART NO. 8104P582-60
DIAGRAM
PART NO. 8104P582-60 2 OF 2

CER3740AAH CER3740AAT

DIAGRAM NO. 8104P532-60

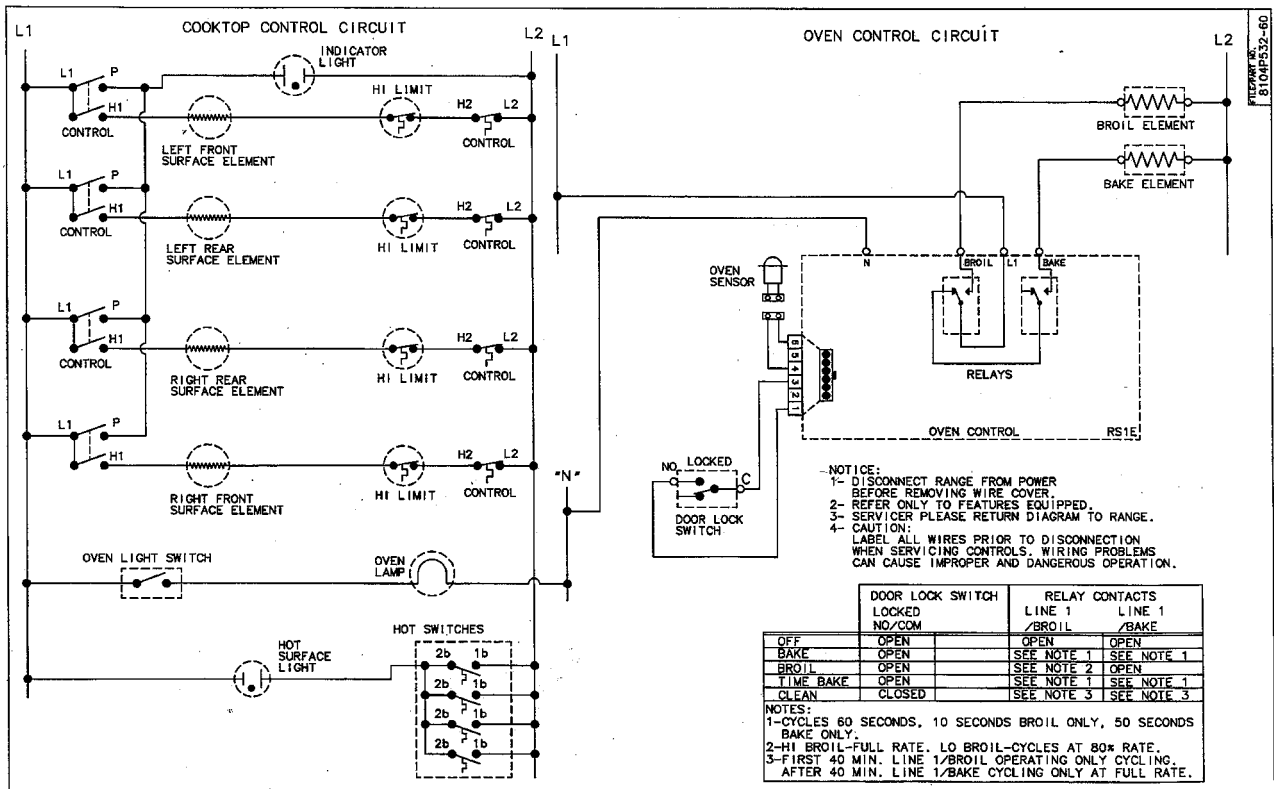
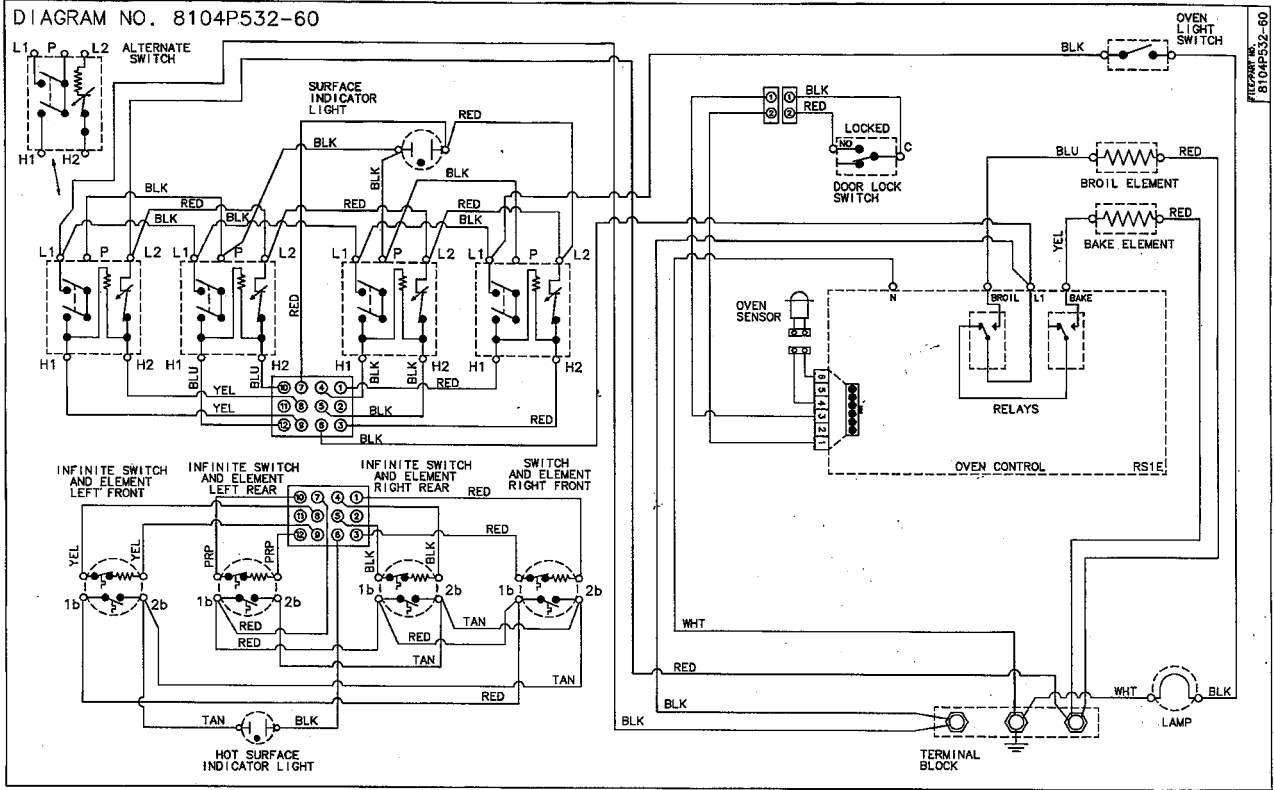

CER3760AAQ CER3765AAC

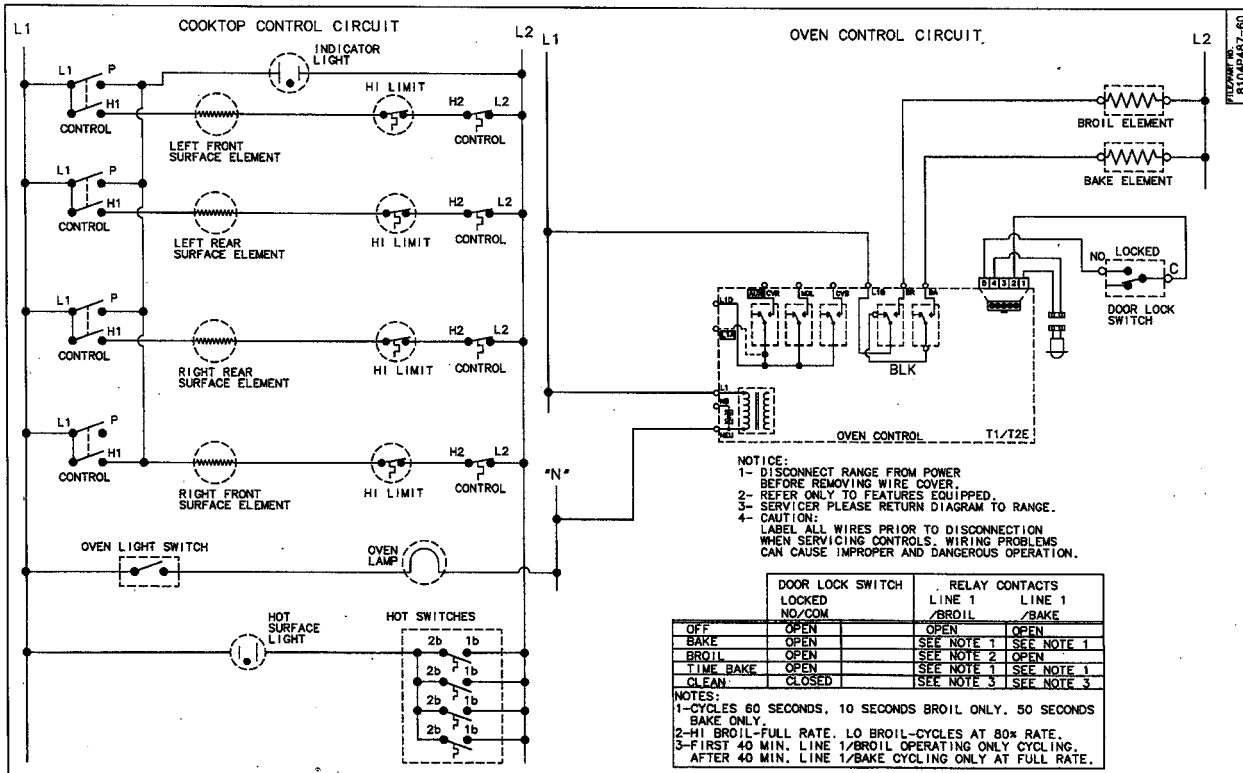
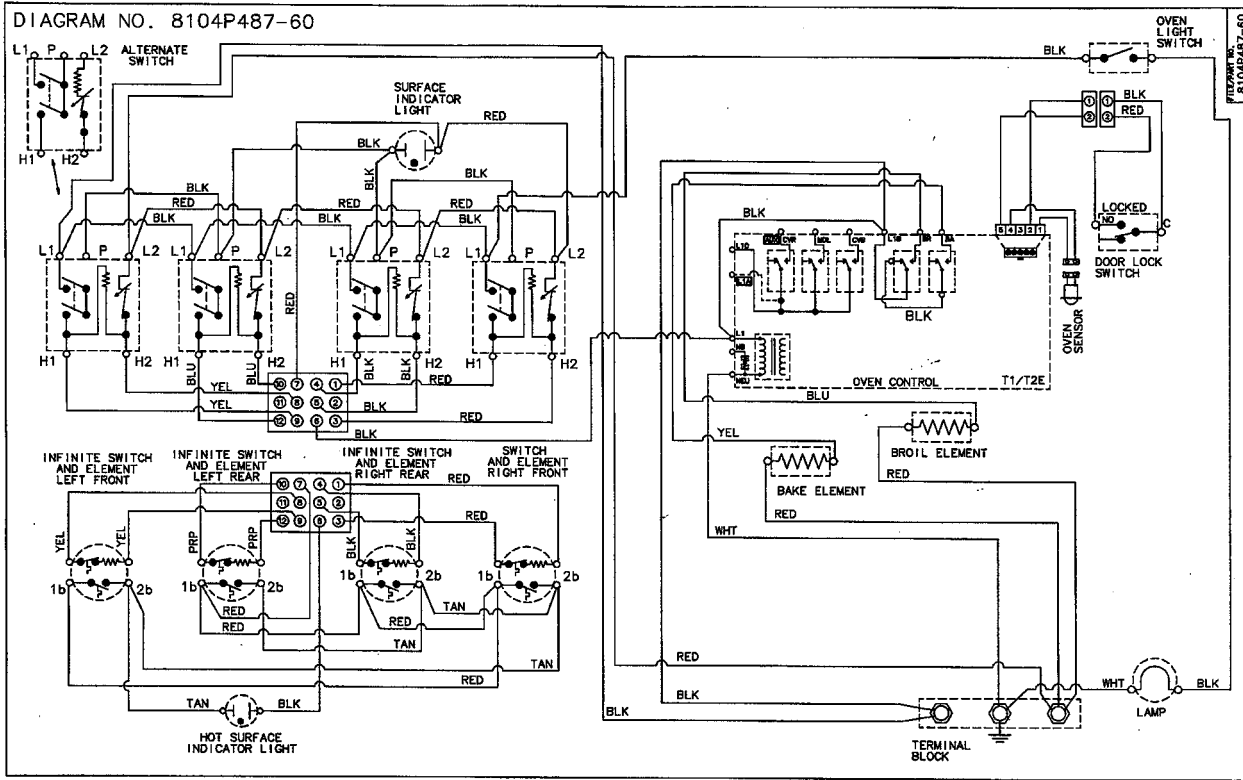

CER3760ACO CER3760ACW

DIAGRAM NO. 8104P593-60

NOTICE:

1. DISCONNECT RANGE FROM POWER BEFORE REMOVING WIRE COVER.
2. REFER ONLY TO FEATURES EQUIPPED.
3. SERVICER PLEASE RETURN DIAGRAM TO RANGE.

4. CAUTION: LABEL ALL WIRES PRIOR TO DISCONNECTION WHEN SERVICING CONTROLS. WIRING PROBLEMS CAN CAUSE IMPROPER AND DANGEROUS OPERATION.
5. VERIFY PROPER OPERATION AFTER SERVICING.

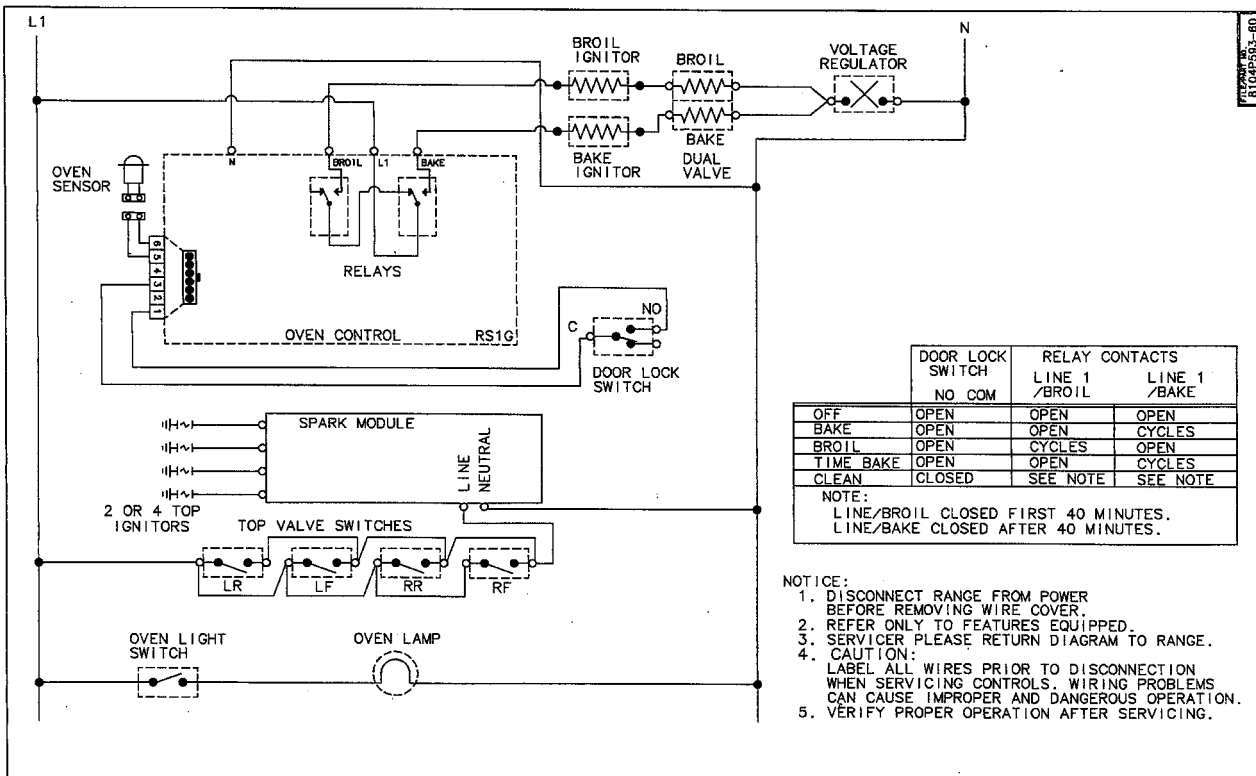
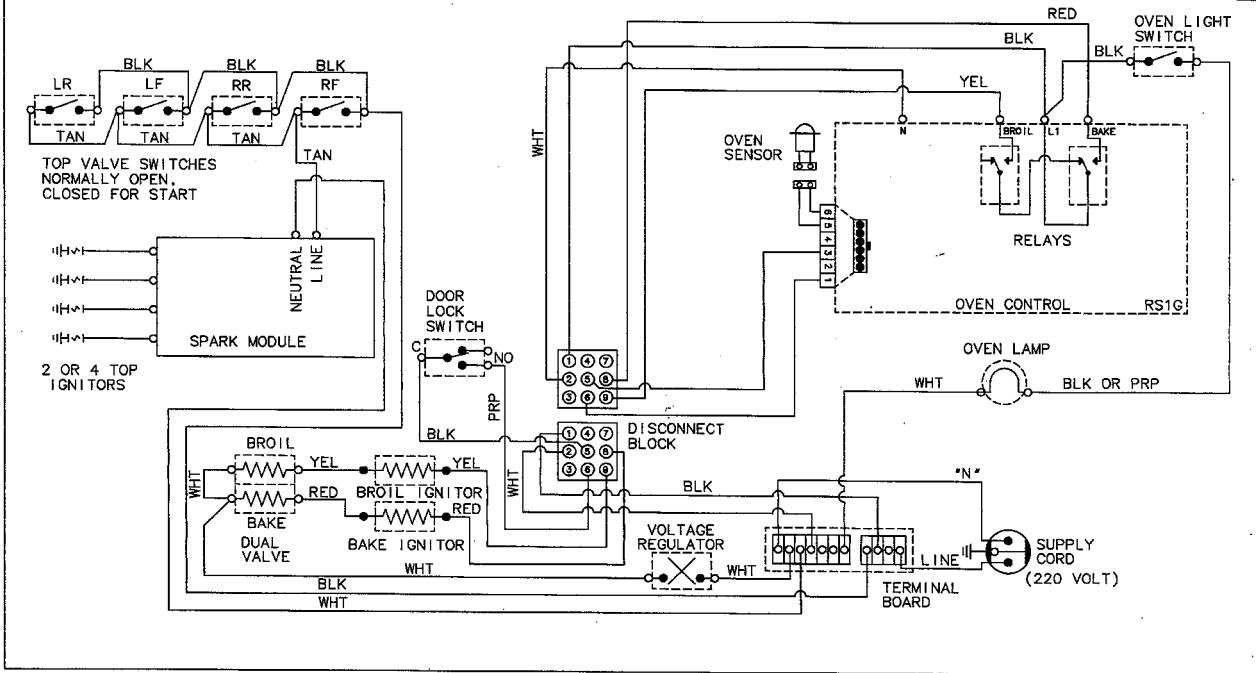

CES1110AAH

DIAGRAM NO. 8104P615-60

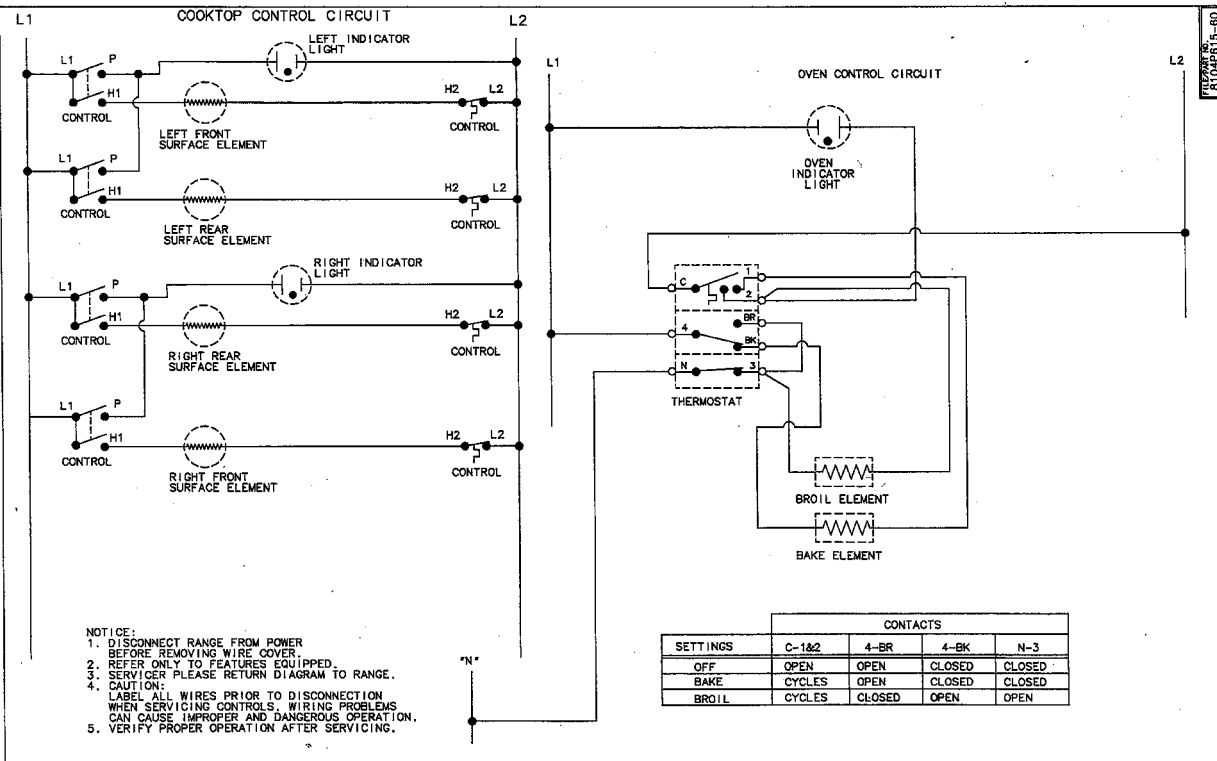
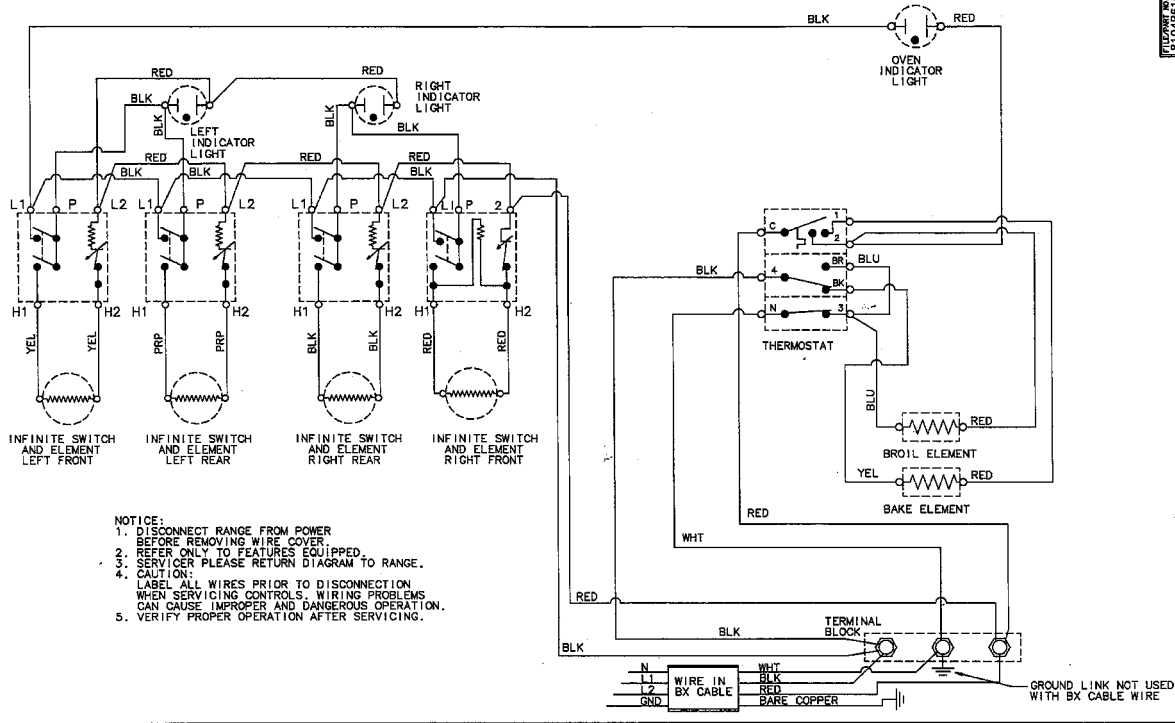

CES1350AAH

DIAGRAM NO. 8104P616-60

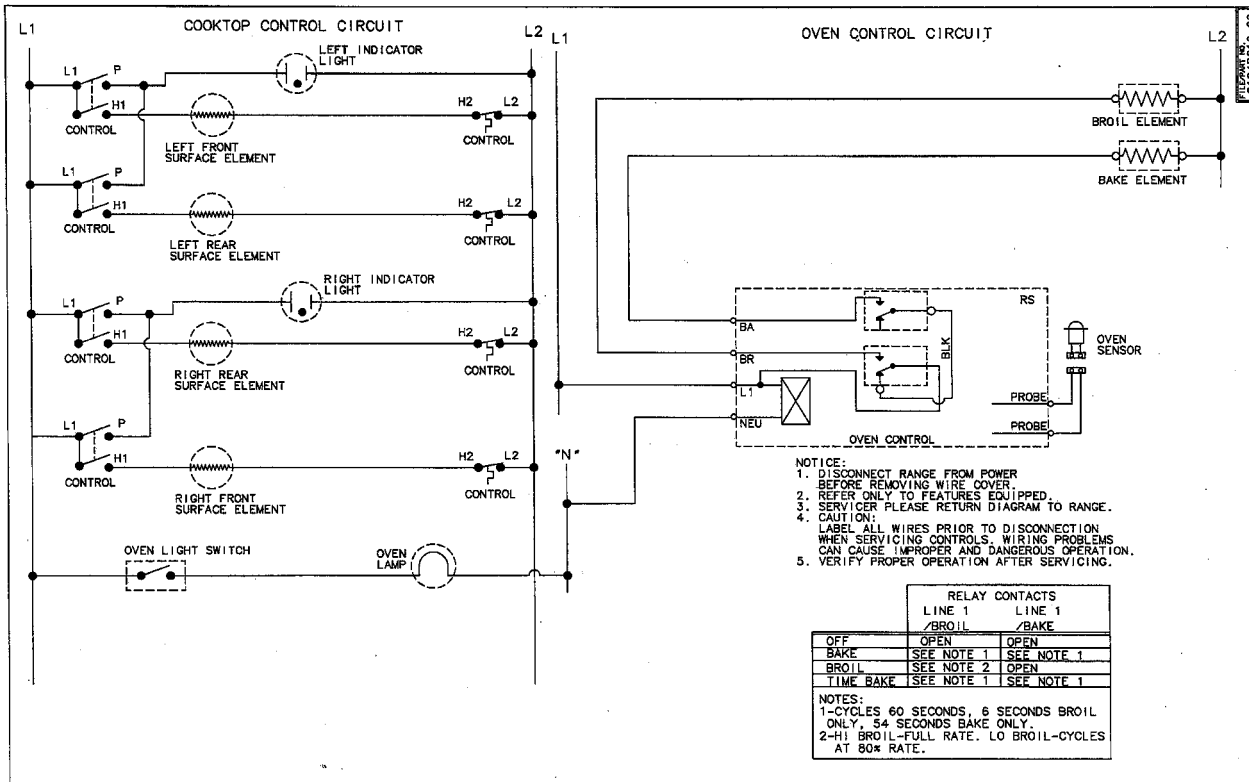
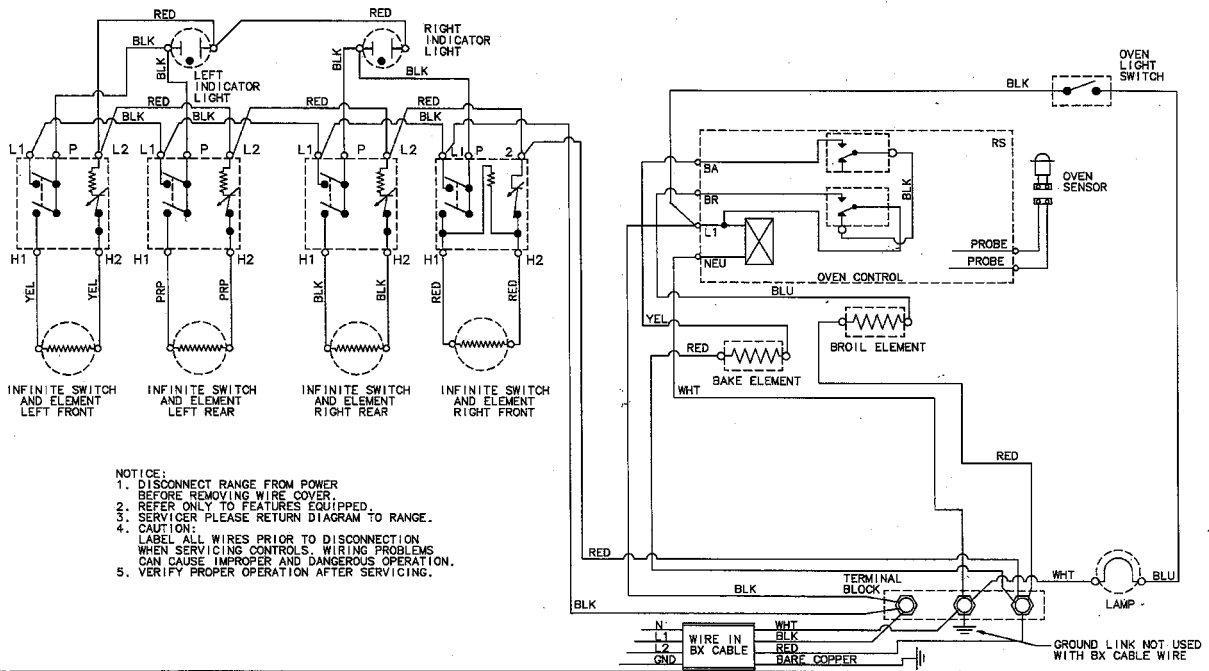

CGS1230ADH CGS1230ADT

DIAGRAM NO.
8104P611-60

FILE NO. 8104P611-60

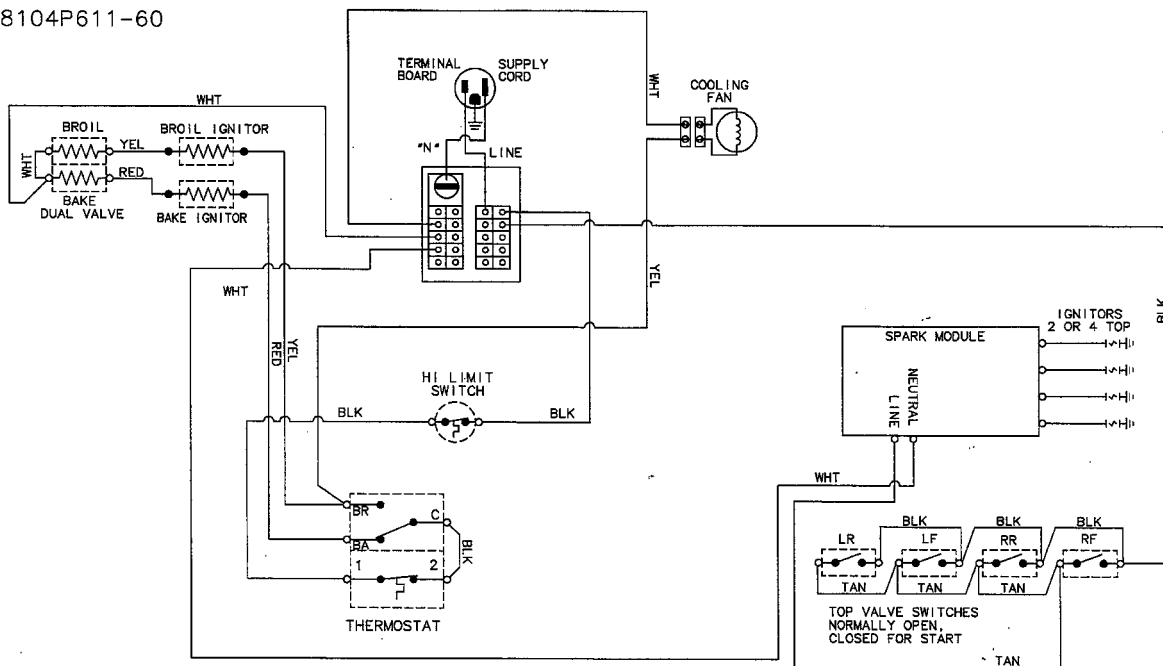

NOTICE:

1. DISCONNECT RANGE FROM POWER BEFORE REMOVING WIRE COVER.
2. REFER ONLY TO FEATURES EQUIPPED.
3. SERVICER PLEASE RETURN DIAGRAM TO RANGE.
4. CAUTION: LABEL ALL WIRES PRIOR TO DISCONNECTION WHEN SERVICING CONTROLS. WIRING PROBLEMS CAN CAUSE IMPROPER AND DANGEROUS OPERATION.
5. VERIFY PROPER OPERATION AFTER SERVICING.

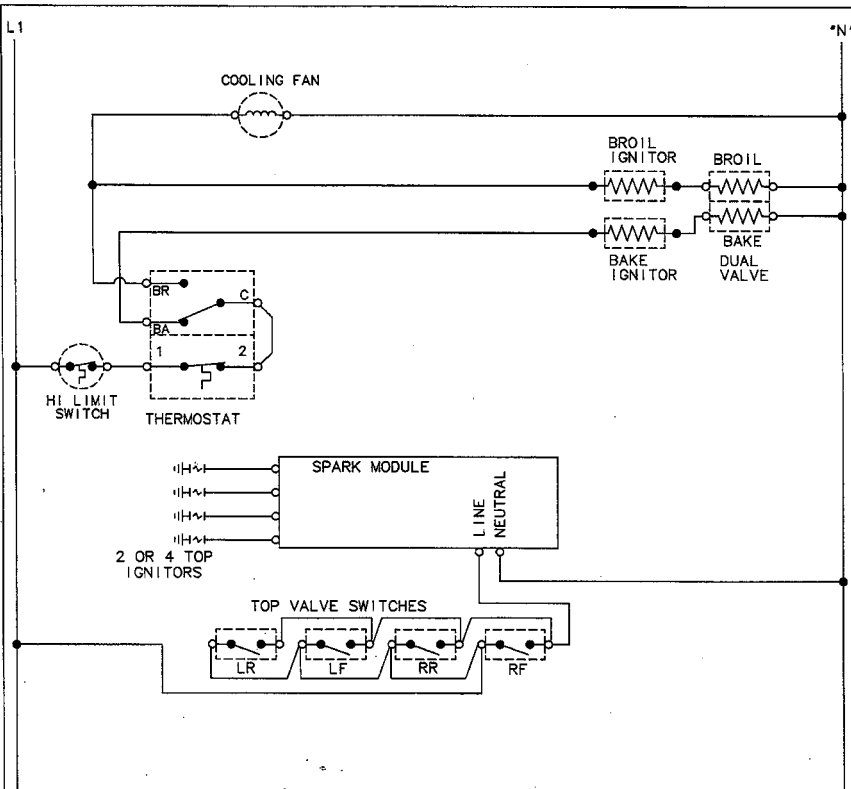

FILE NO. 8104P611-60

NOTICE:

1. DISCONNECT RANGE FROM POWER BEFORE REMOVING WIRE COVER.
2. REFER ONLY TO FEATURES EQUIPPED.
3. SERVICER PLEASE RETURN DIAGRAM TO RANGE.
4. CAUTION: LABEL ALL WIRES PRIOR TO DISCONNECTION WHEN SERVICING CONTROLS. WIRING PROBLEMS CAN CAUSE IMPROPER AND DANGEROUS OPERATION.
5. VERIFY PROPER OPERATION AFTER SERVICING.

CGS1740ADH CGS1740ADT

DIAGRAM NO.
8104P612-60

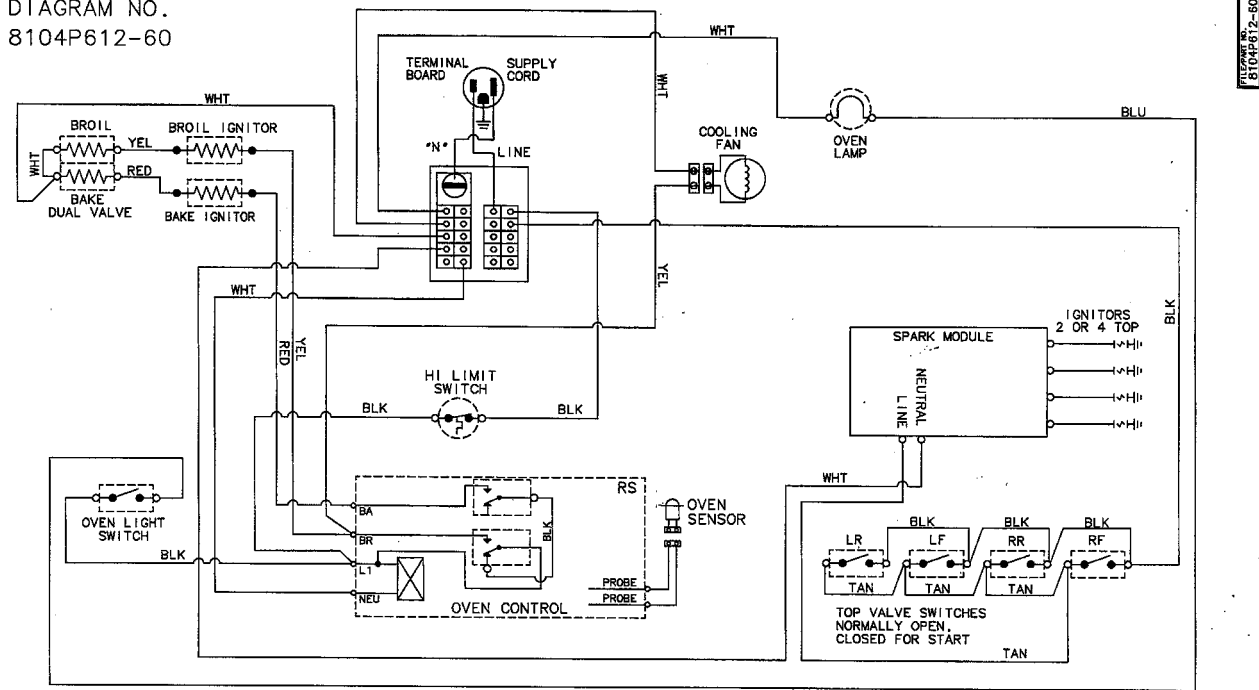

- NOTICE:
1. DISCONNECT RANGE FROM POWER BEFORE REMOVING WIRE COVER.
 2. REFER ONLY TO FEATURES EQUIPPED.
 3. SERVICER PLEASE RETURN DIAGRAM TO RANGE.
 4. CAUTION: LABEL ALL WIRES PRIOR TO DISCONNECTION WHEN SERVICING CONTROLS. WIRING PROBLEMS CAN CAUSE IMPROPER AND DANGEROUS OPERATION.
 5. VERIFY PROPER OPERATION AFTER SERVICING.

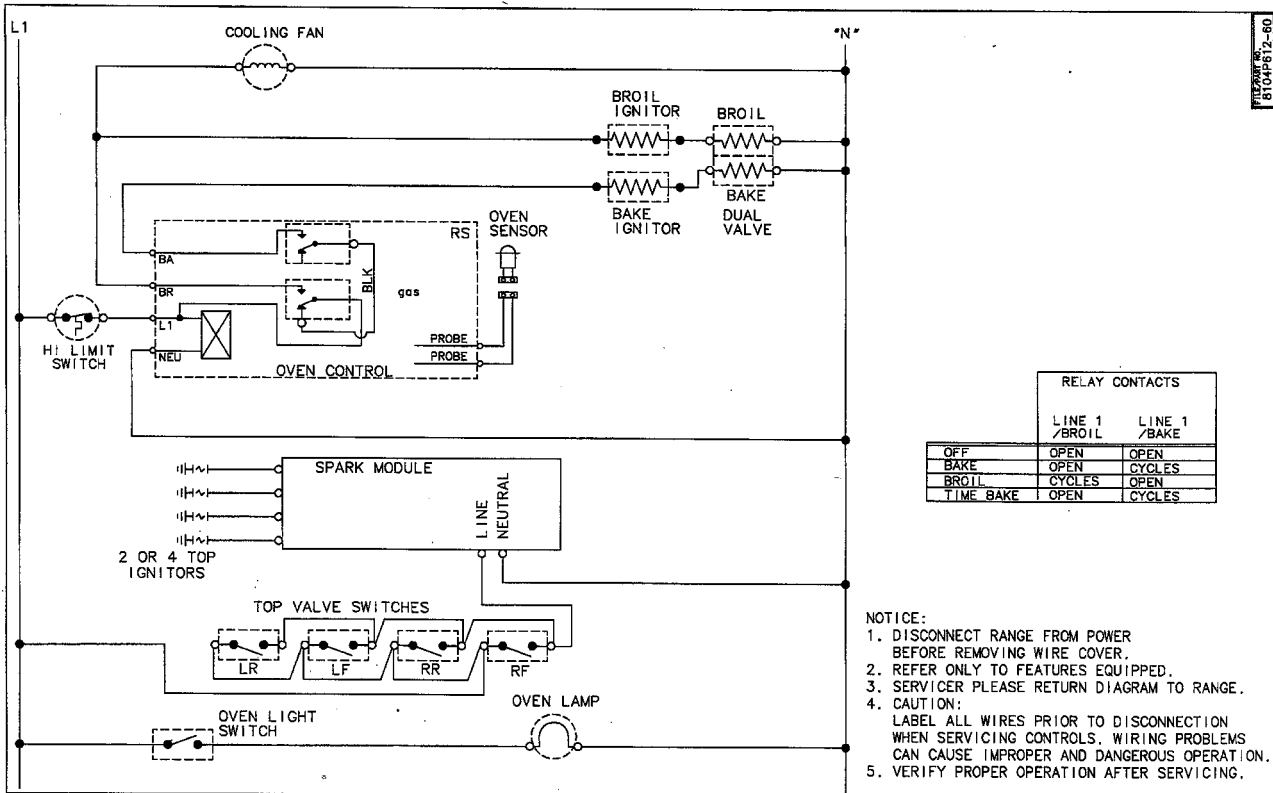

CGS3760ACB CGS3760ADC CGS3760ADQ CGS3760ADW

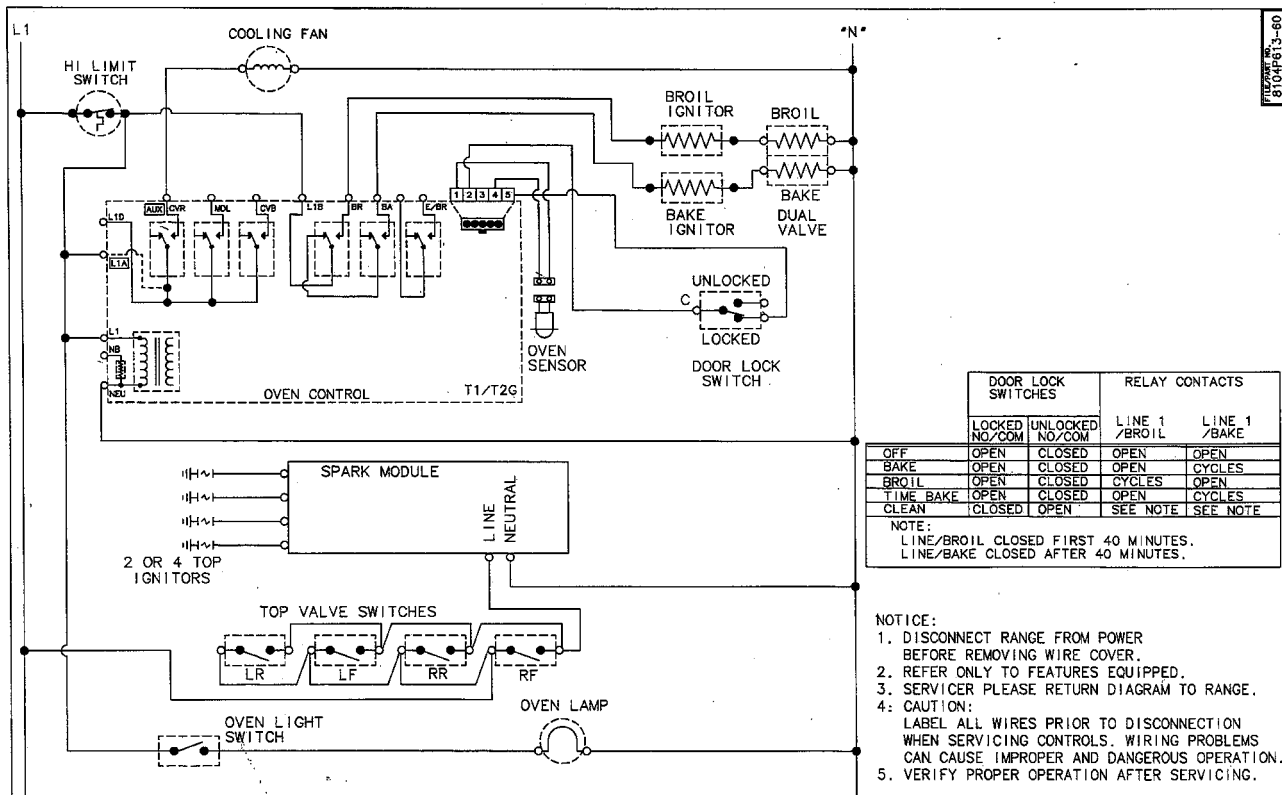
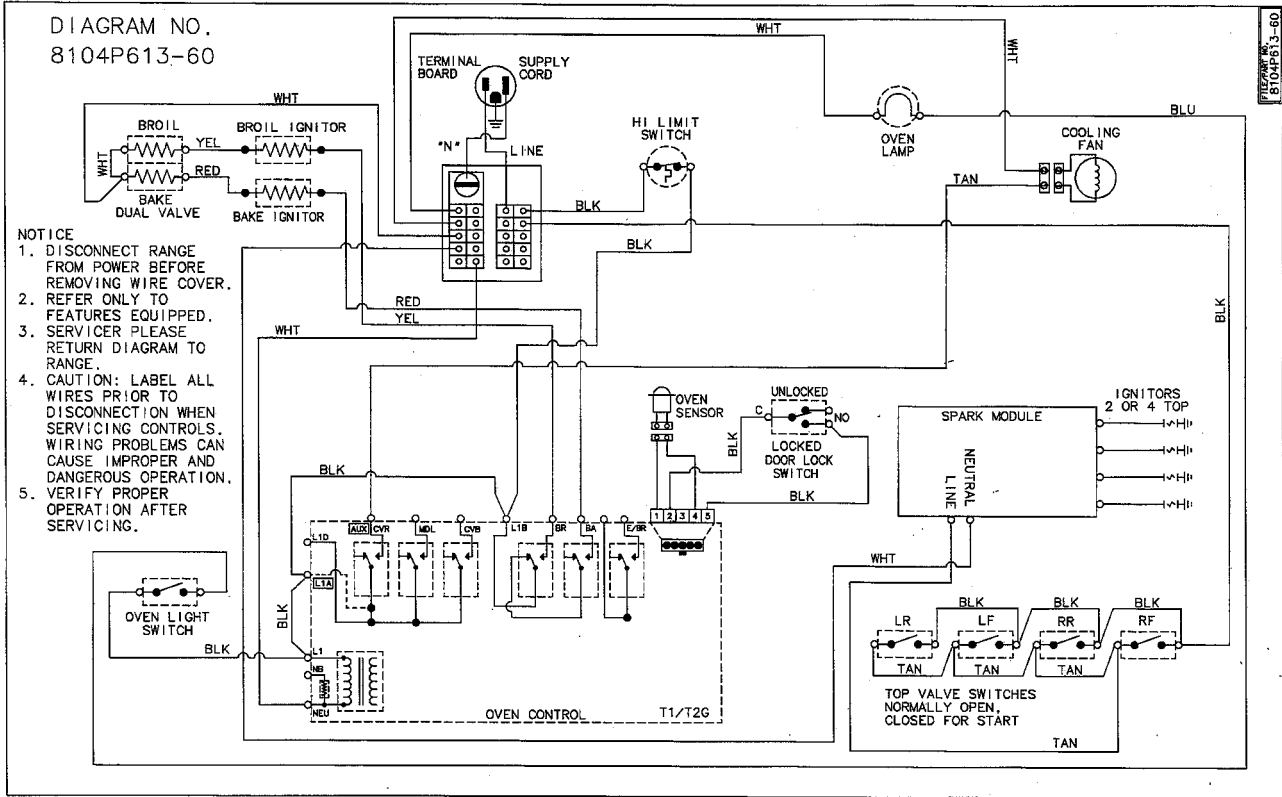

Crosley Models: CG34300ADT CG34300ADW

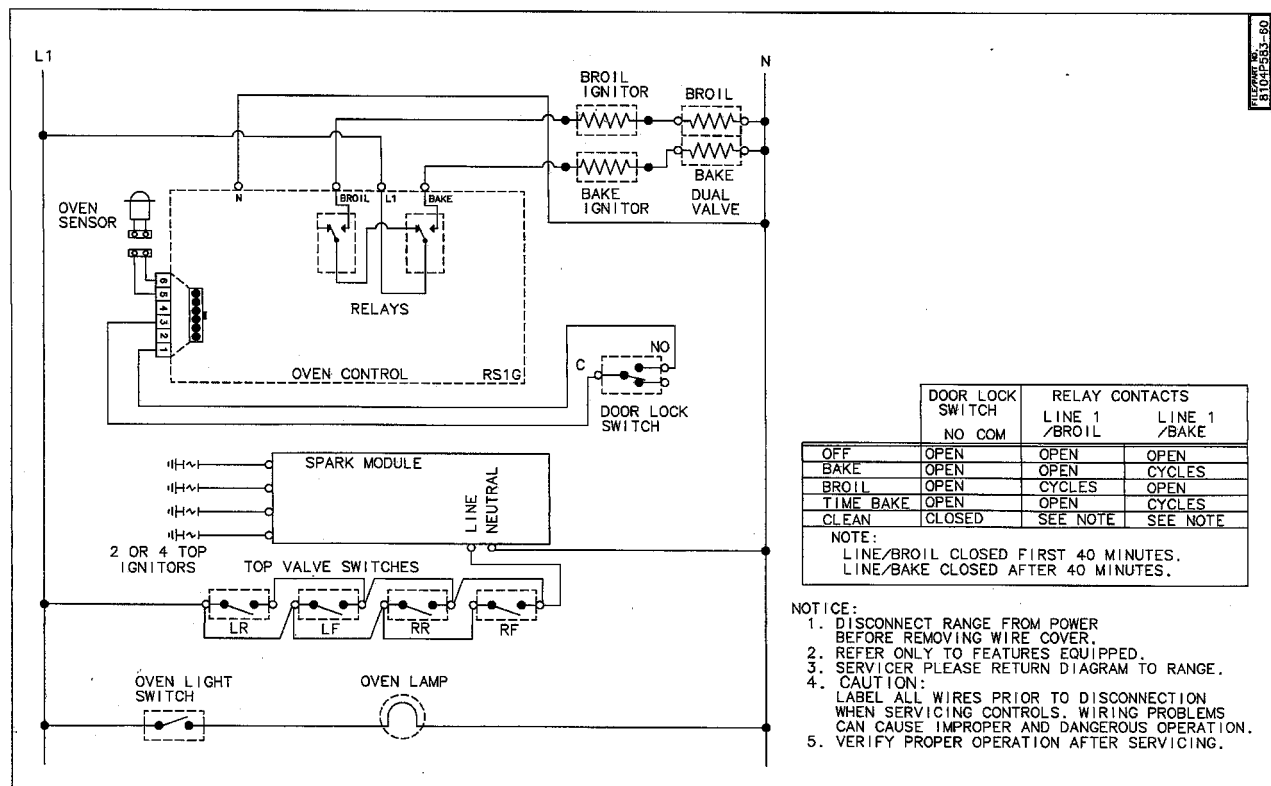
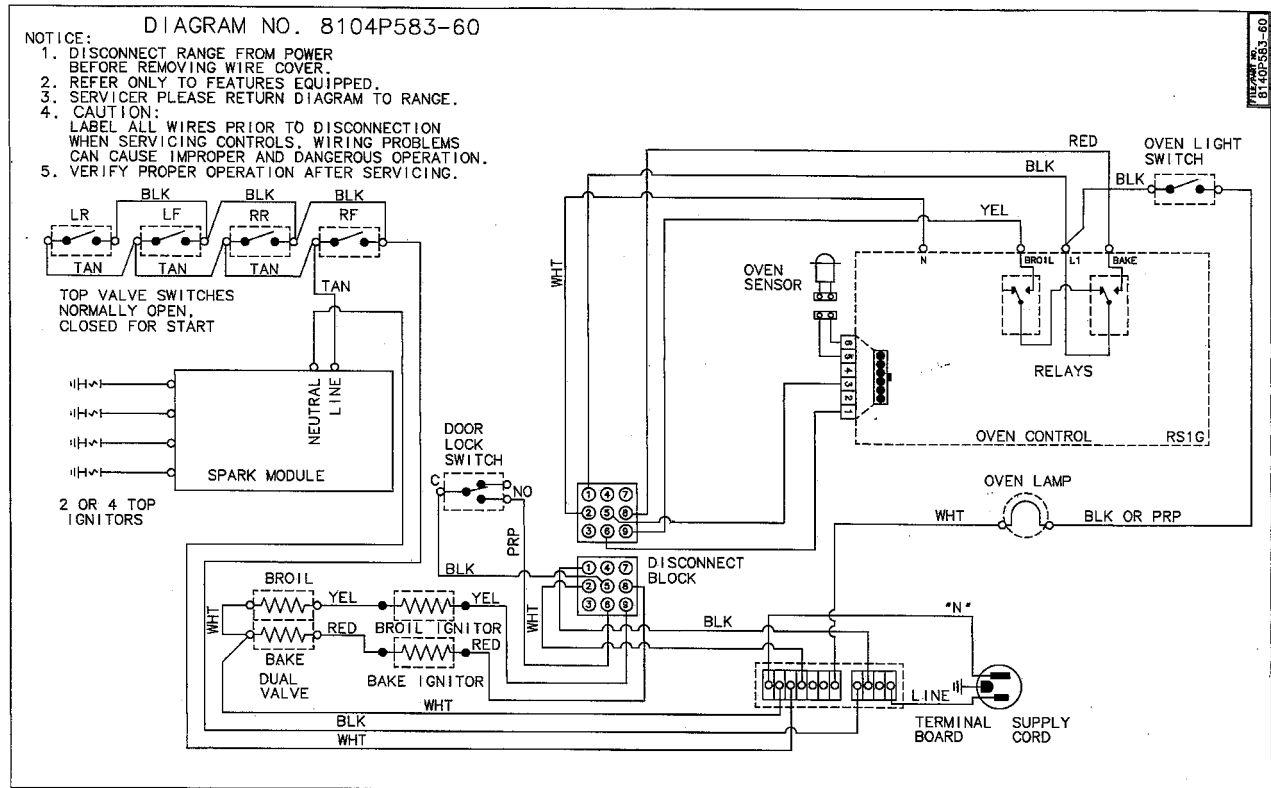

CG34700ADO CG34700ADV

DIAGRAM NO. 8104P584-60

NOTICE:

1. DISCONNECT RANGE FROM POWER BEFORE REMOVING WIRE COVER.
2. REFER ONLY TO FEATURES EQUIPPED.
3. SERVICER PLEASE RETURN DIAGRAM TO RANGE.
4. CAUTION: LABEL ALL WIRES PRIOR TO DISCONNECTION. WHEN SERVICING CONTROLS, WIRING PROBLEMS CAN CAUSE IMPROPER AND DANGEROUS OPERATION.
5. VERIFY PROPER OPERATION AFTER SERVICING.

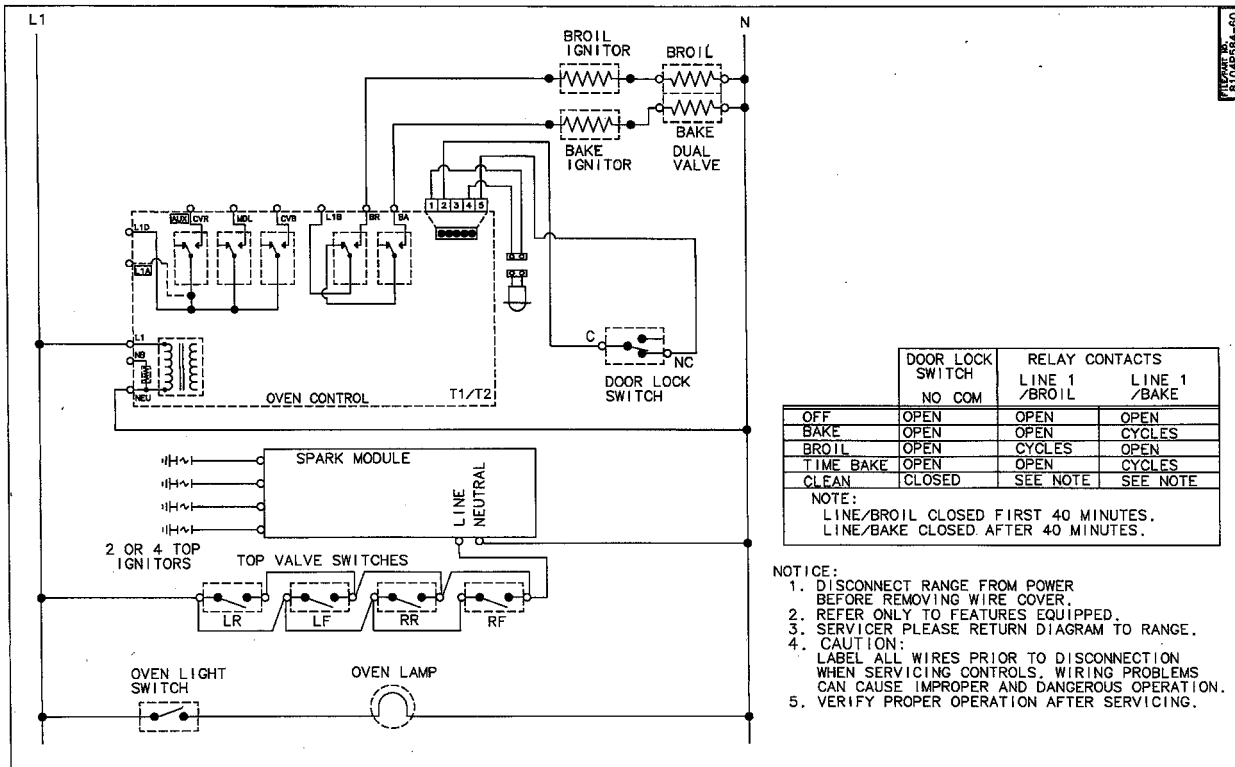
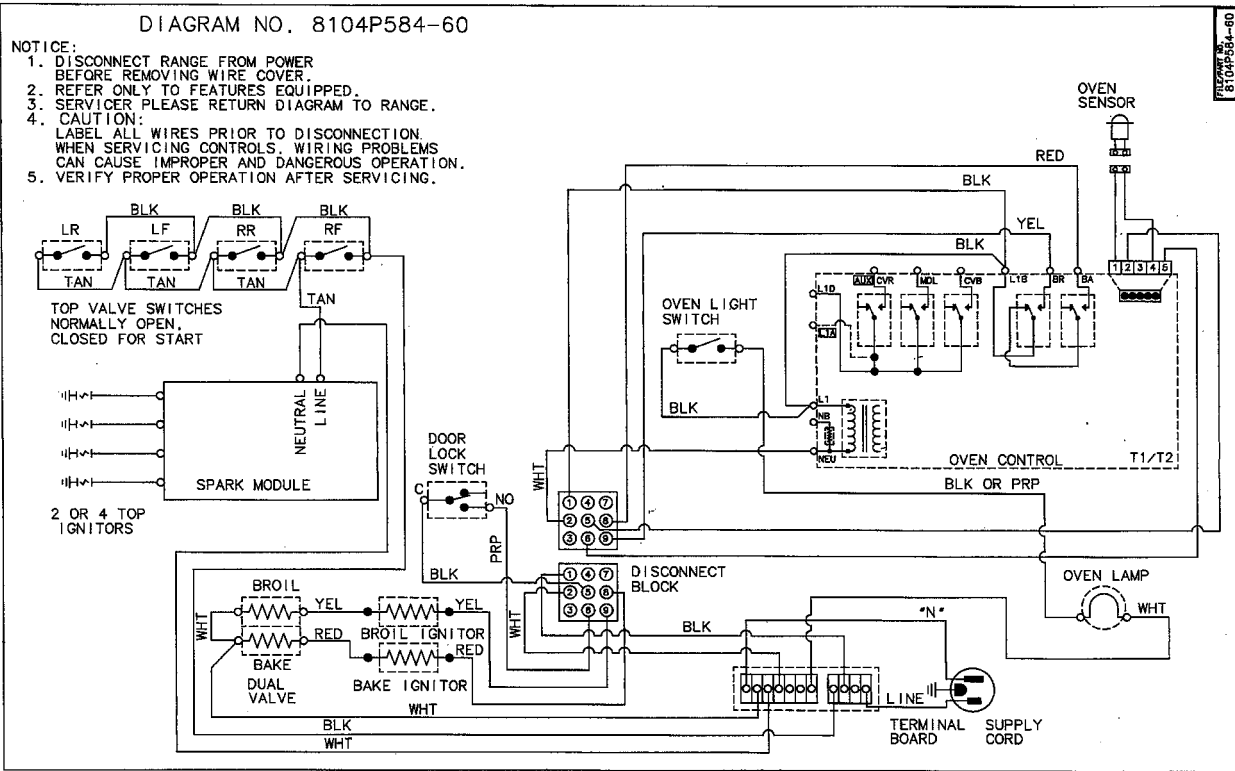

C31000PAT* C31000PAW * C31100PAV * C31100SAT* C31100SATP* C31100SAW*
C31100SAWP*



IMPORTANT

Wiring information in this manual was accurate at the time of manual production. Wiring information is subject to change at any time. Please refer to wiring information on the actual product for most current information.

*Because of the simple design of this appliance, wiring is minimal. No engineering diagrams are available. Please refer to information supplied with the unit.

C31103SAT C31103SAW C31113WAT C31113WATP C31113WAV C31113WAVP
 C31113XAT C31113XAW

PART NO. 8104P564-60

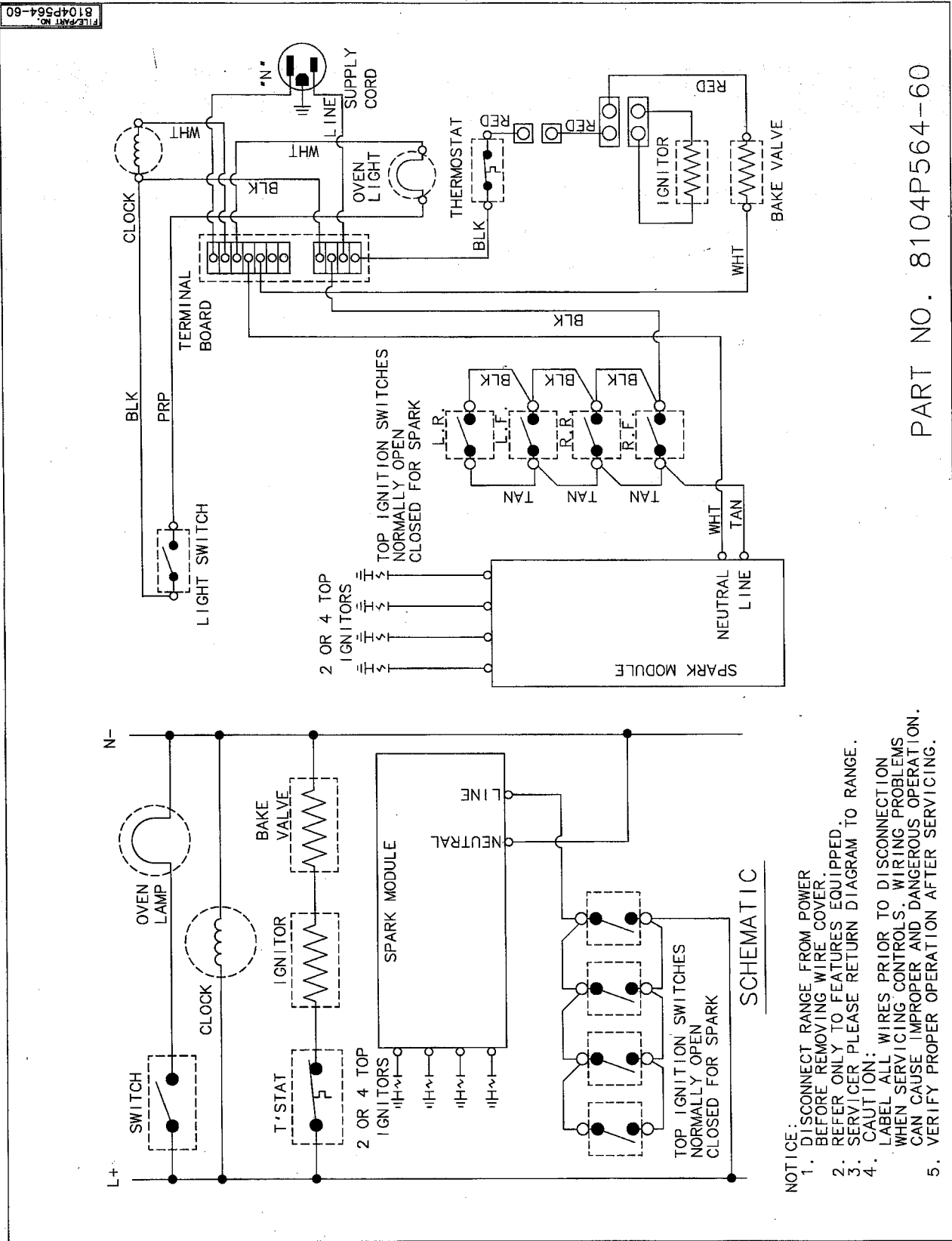

FILE/PART NO. 8104P564-60

- NOTICE:
1. DISCONNECT RANGE FROM POWER BEFORE REMOVING WIRE COVER.
 2. REFER ONLY TO FEATURES EQUIPPED.
 3. SERVICER PLEASE RETURN DIAGRAM TO RANGE.
 4. CAUTION: LABEL ALL WIRES PRIOR TO DISCONNECTION WHEN SERVICING CONTROLS. WIRING PROBLEMS CAN CAUSE IMPROPER AND DANGEROUS OPERATION.
 5. VERIFY PROPER OPERATION AFTER SERVICING.

C31315VBQ

PART NO. 8104P626-60

NOTICE:

1. DISCONNECT RANGE FROM POWER BEFORE REMOVING WIRE COVER.
2. REFER ONLY TO FEATURES EQUIPPED.
3. SERVICER PLEASE RETURN DIAGRAM TO RANGE.
4. CAUTION: LABEL ALL WIRES PRIOR TO DISCONNECTION WHEN SERVICING CONTROLS. WIRING PROBLEMS CAN CAUSE IMPROPER AND DANGEROUS OPERATION.
5. VERIFY PROPER OPERATION AFTER SERVICING.

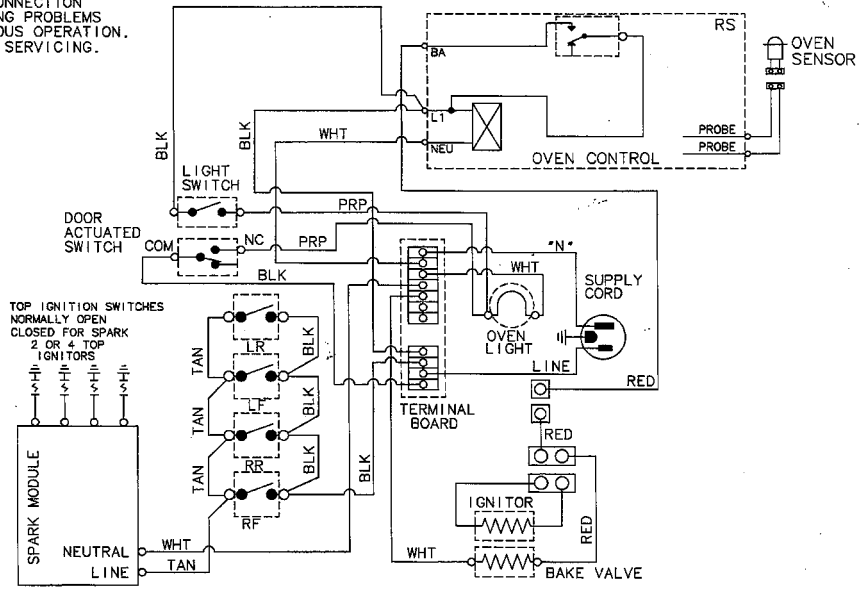

FILE NO. 8104P626-60

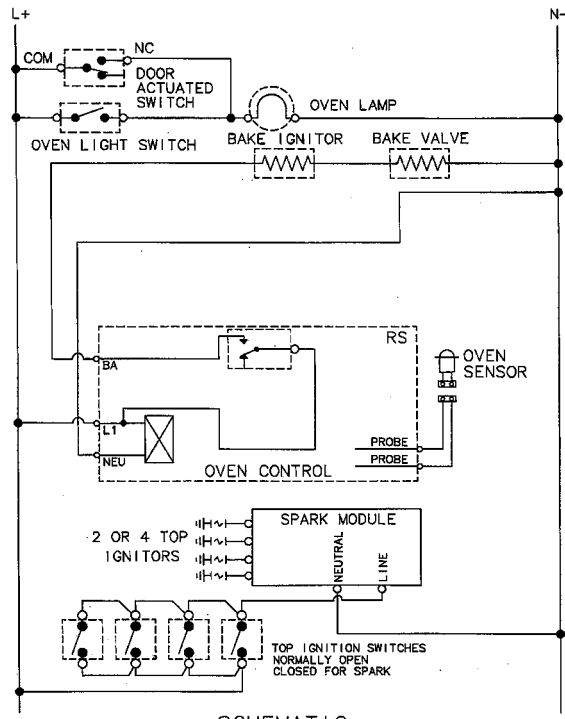

SCHMATIC

NOTICE:

1. DISCONNECT RANGE FROM POWER BEFORE REMOVING WIRE COVER.
2. REFER ONLY TO FEATURES EQUIPPED.
3. SERVICER PLEASE RETURN DIAGRAM TO RANGE.
4. CAUTION: LABEL ALL WIRES PRIOR TO DISCONNECTION WHEN SERVICING CONTROLS. WIRING PROBLEMS CAN CAUSE IMPROPER AND DANGEROUS OPERATION.
5. VERIFY PROPER OPERATION AFTER SERVICING.

FILE NO. 8104P626-60

C31315VBV

PART NO. 8104P626-60

NOTICE:

1. DISCONNECT RANGE FROM POWER BEFORE REMOVING WIRE COVER.
2. REFER ONLY TO FEATURES EQUIPPED.
3. SERVICER PLEASE RETURN DIAGRAM TO RANGE.
4. CAUTION: LABEL ALL WIRES PRIOR TO DISCONNECTION WHEN SERVICING CONTROLS. WIRING PROBLEMS CAN CAUSE IMPROPER AND DANGEROUS OPERATION.
5. VERIFY PROPER OPERATION AFTER SERVICING.

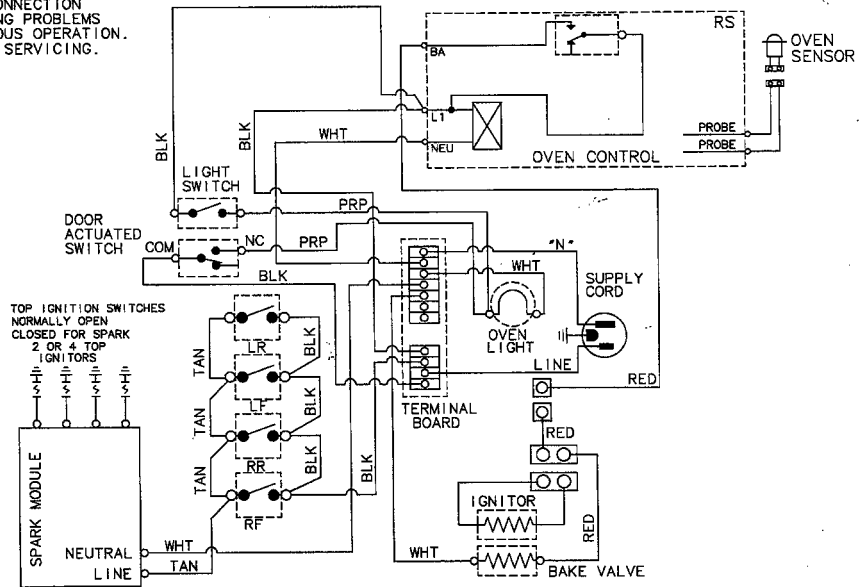

FILE NO. 8104P626-60

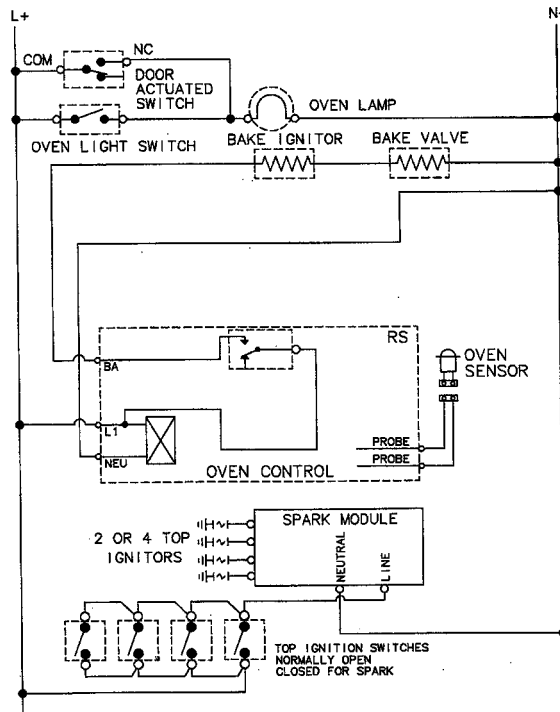

SCHMATIC

NOTICE:

1. DISCONNECT RANGE FROM POWER BEFORE REMOVING WIRE COVER.
2. REFER ONLY TO FEATURES EQUIPPED.
3. SERVICER PLEASE RETURN DIAGRAM TO RANGE.
4. CAUTION: LABEL ALL WIRES PRIOR TO DISCONNECTION WHEN SERVICING CONTROLS. WIRING PROBLEMS CAN CAUSE IMPROPER AND DANGEROUS OPERATION.
5. VERIFY PROPER OPERATION AFTER SERVICING.

FILE NO. 8104P626-60

CC35111BCV

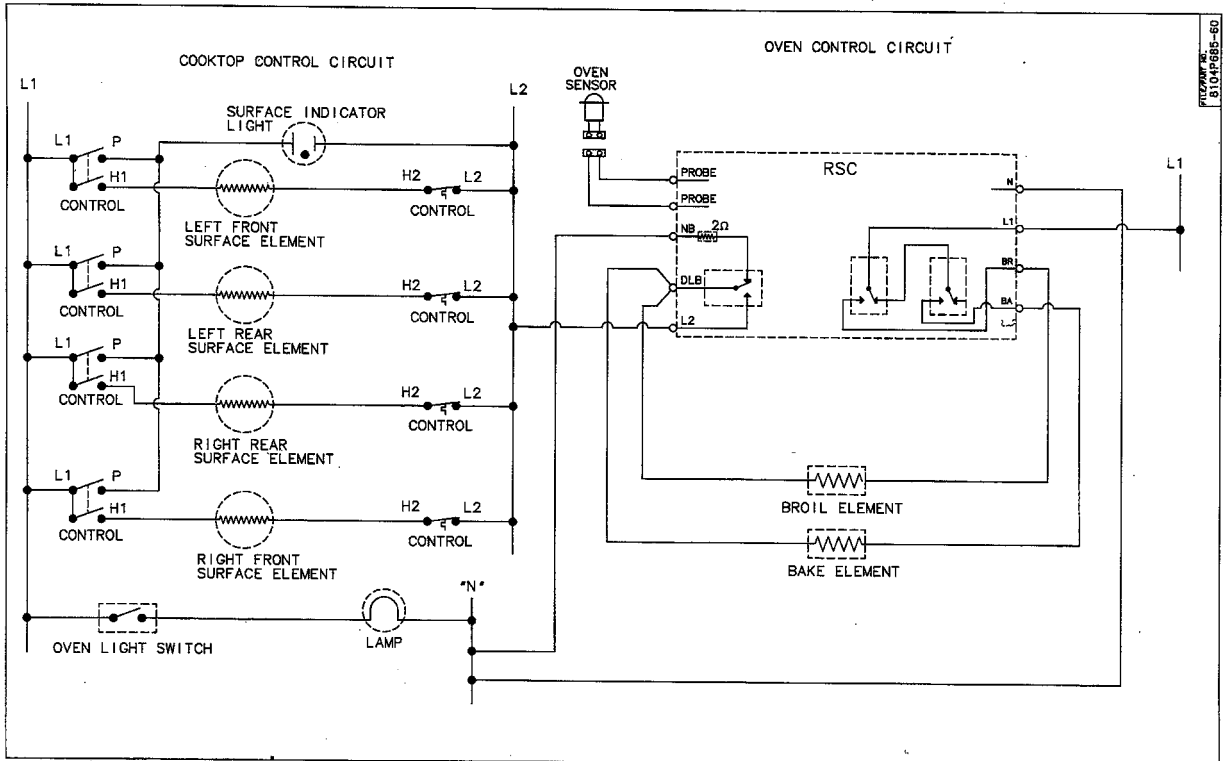
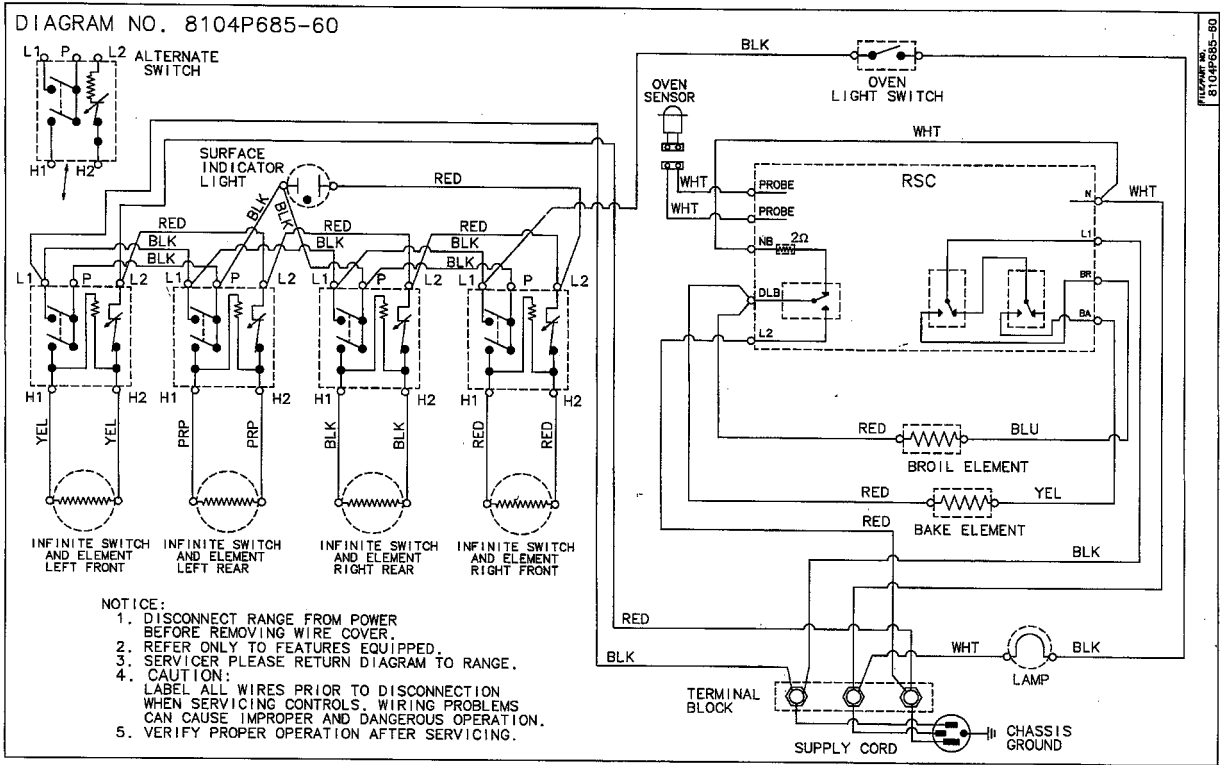

CC38700ACV

DIAGRAM NO. 8104P593-60

- NOTICE:
1. DISCONNECT RANGE FROM POWER BEFORE REMOVING WIRE COVER.
 2. REFER ONLY TO FEATURES EQUIPPED.
 3. SERVICER PLEASE RETURN DIAGRAM TO RANGE.

4. CAUTION: LABEL ALL WIRES PRIOR TO DISCONNECTION WHEN SERVICING CONTROLS WIRING PROBLEMS CAN CAUSE IMPROPER AND DANGEROUS OPERATION.
5. VERIFY PROPER OPERATION AFTER SERVICING.

8104P593-60

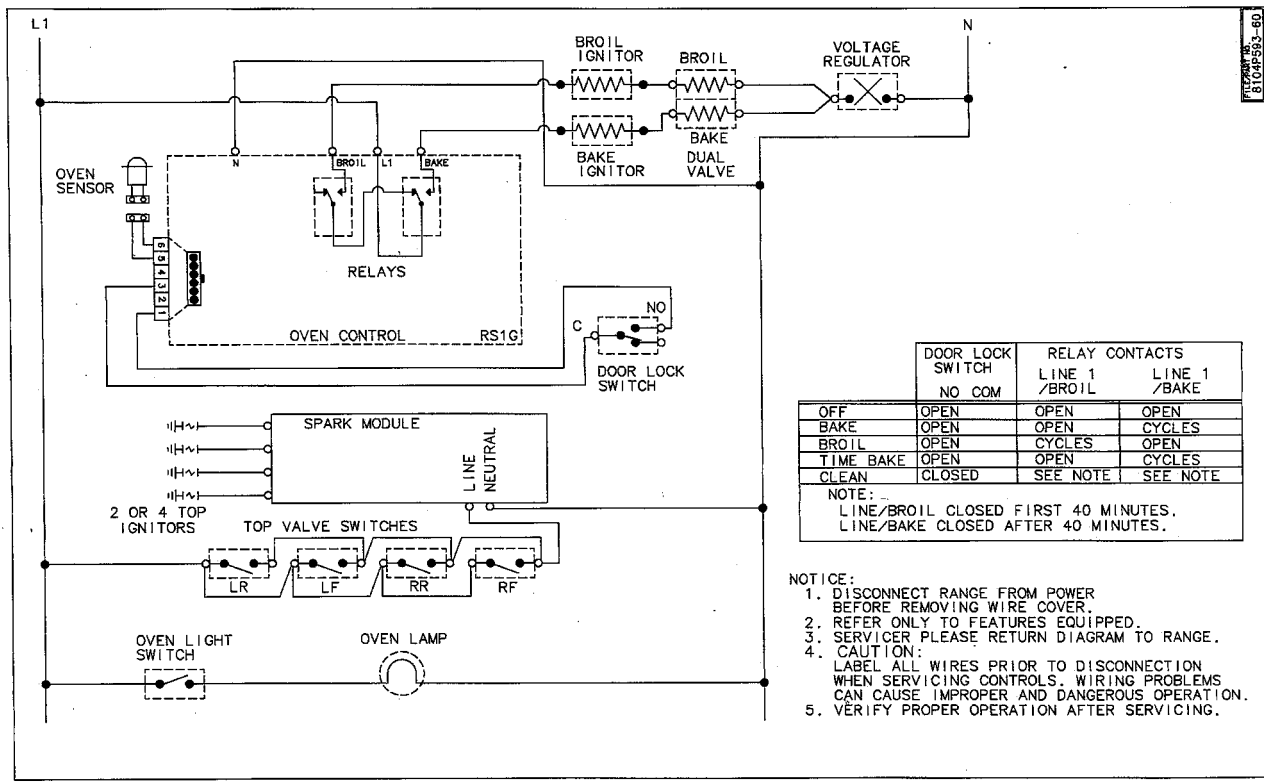
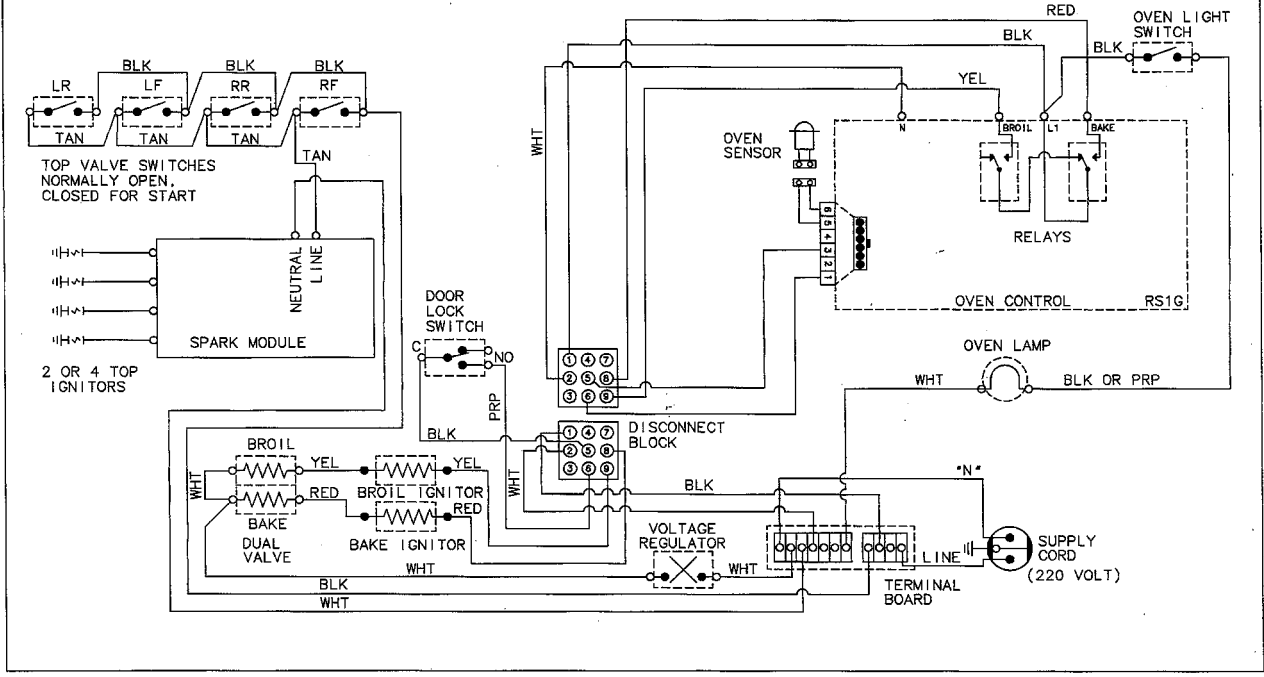

8104P593-60

CE3500AAT CE3500AAW

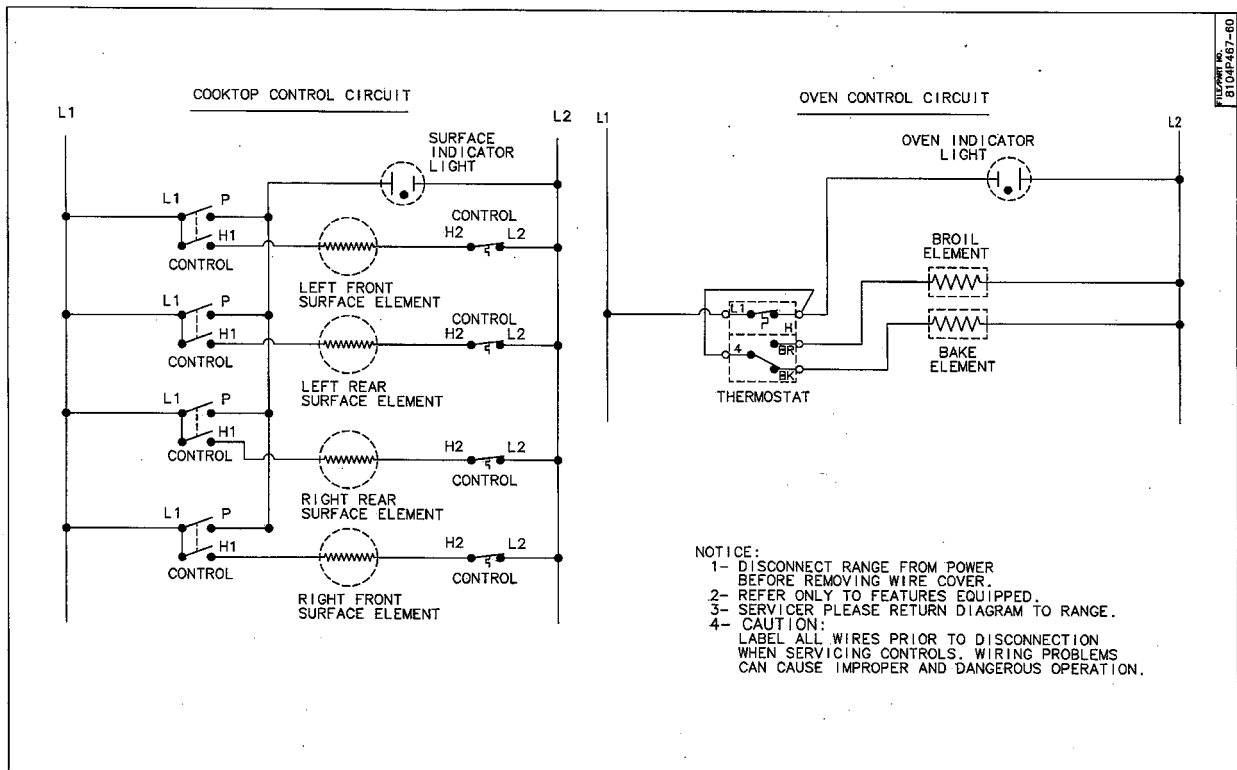
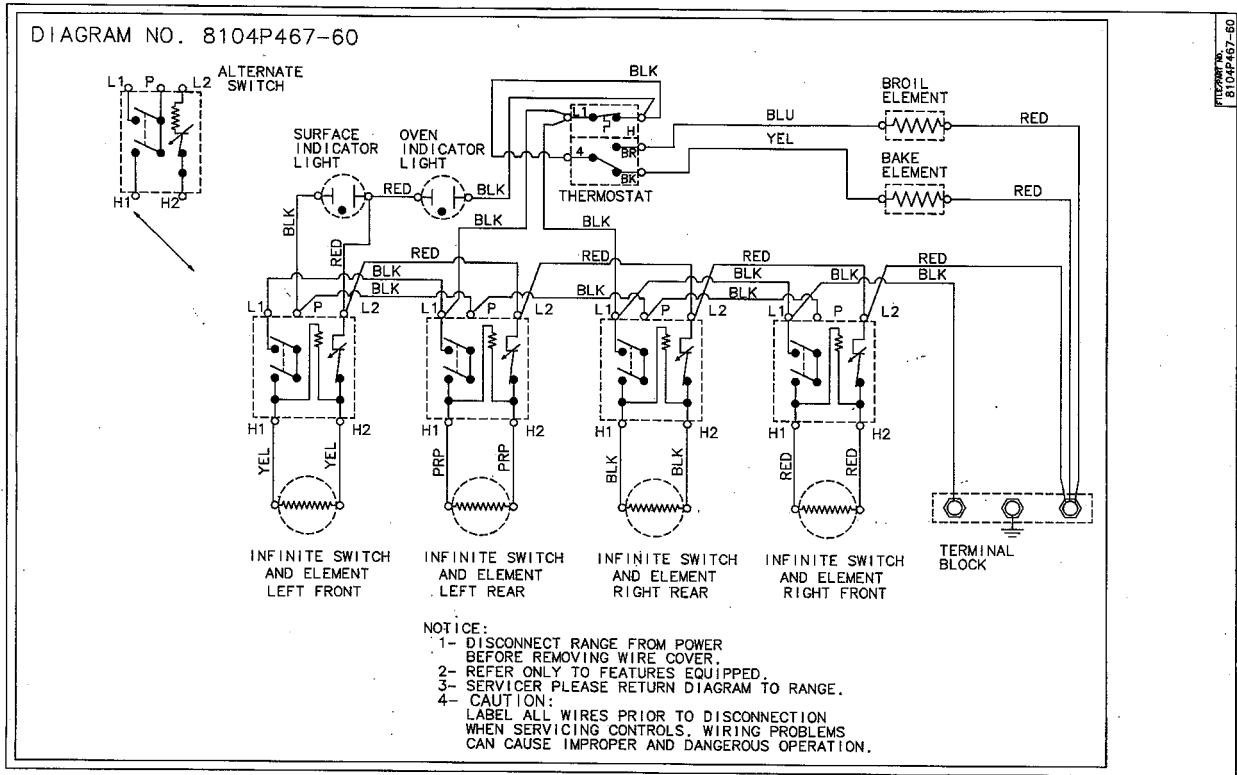

CE35100AAT CE35100AAW

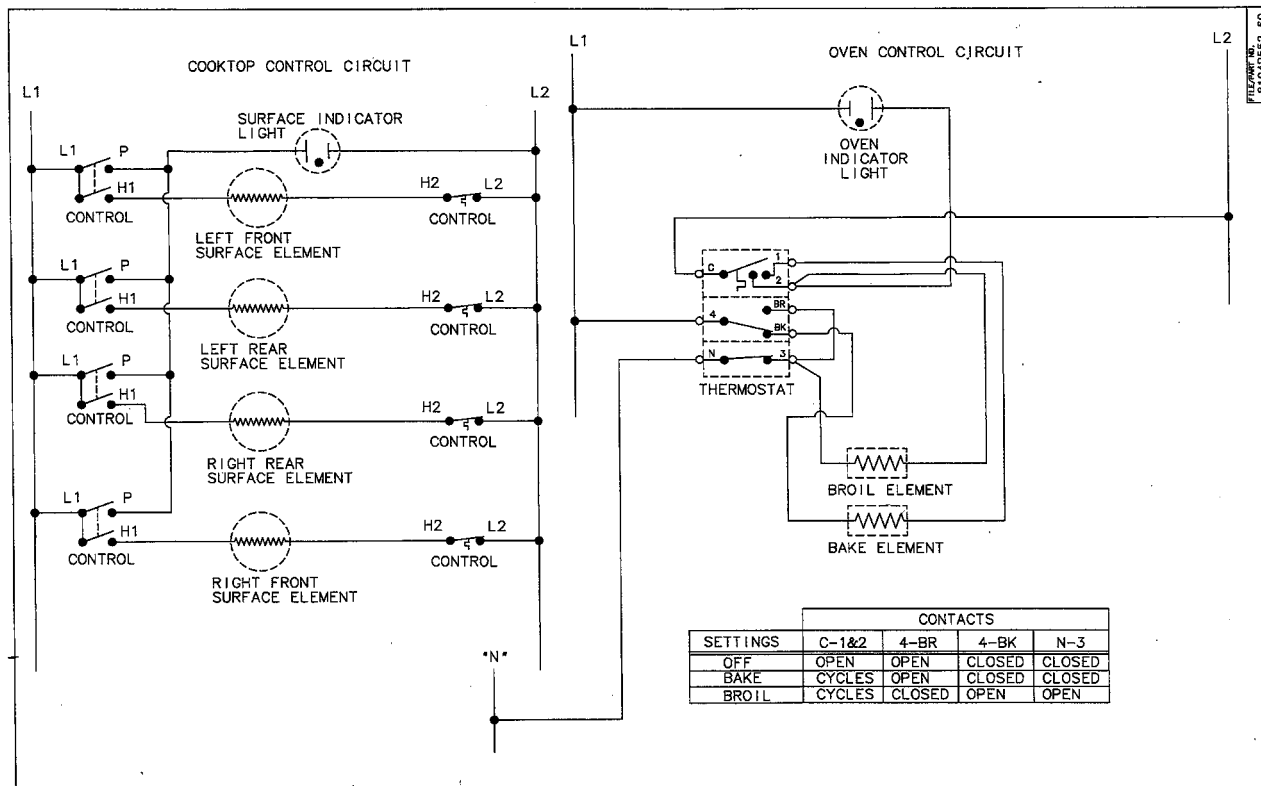
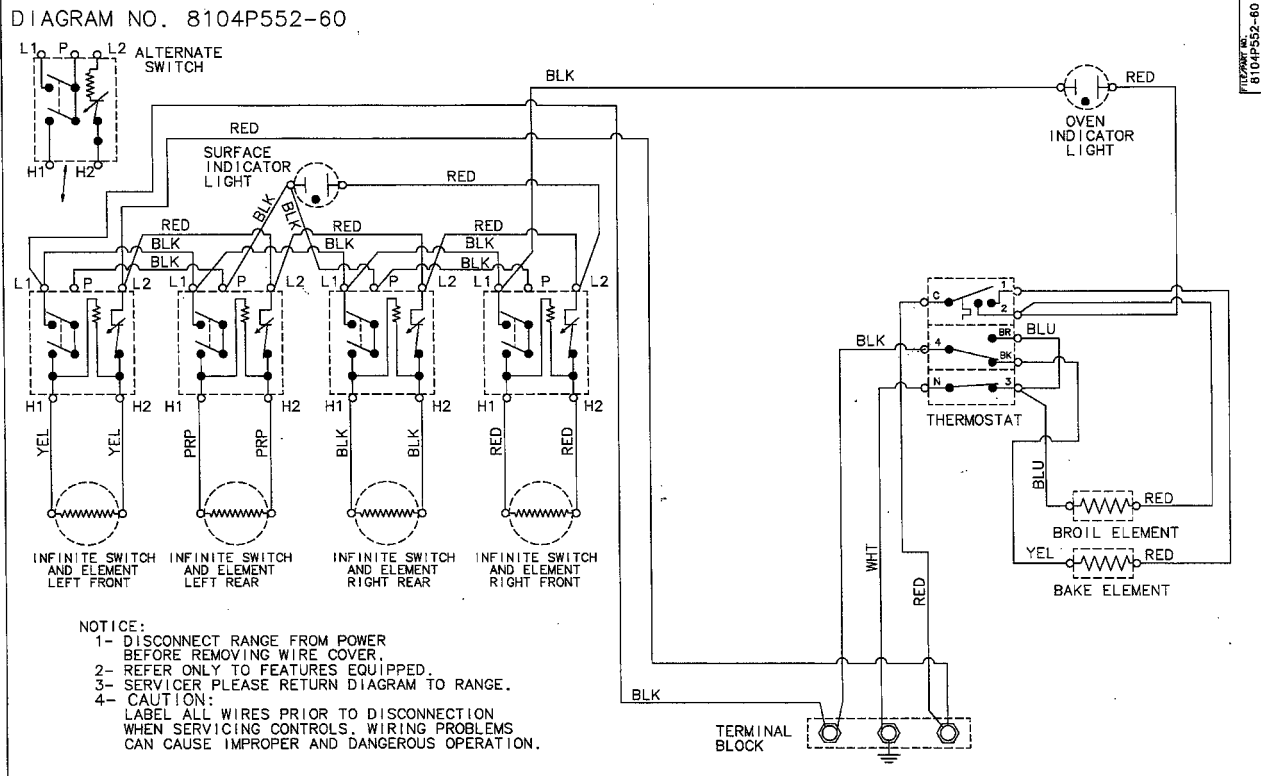

CE35111AAQ CE35111AAT CE35111AAV CE35111AAW

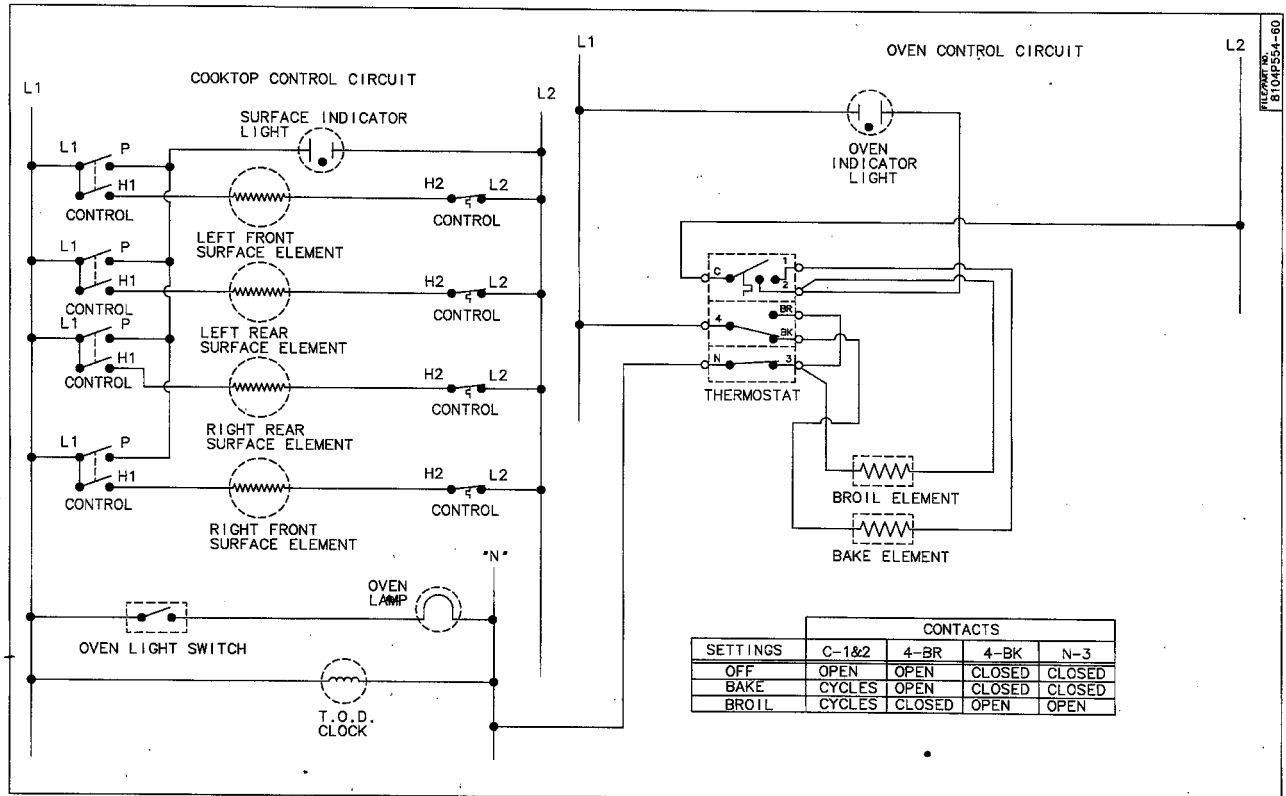
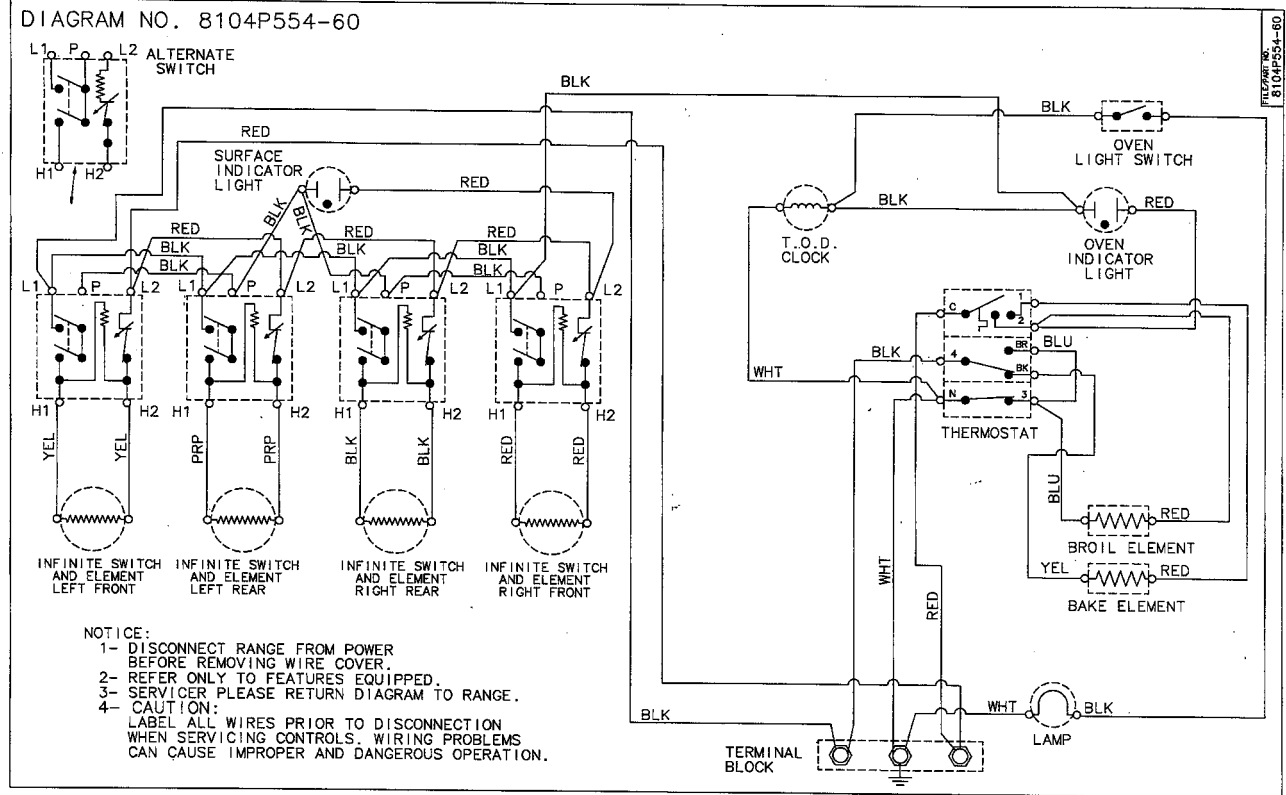

CE3800AAT CE3800AAW CE38300AAV

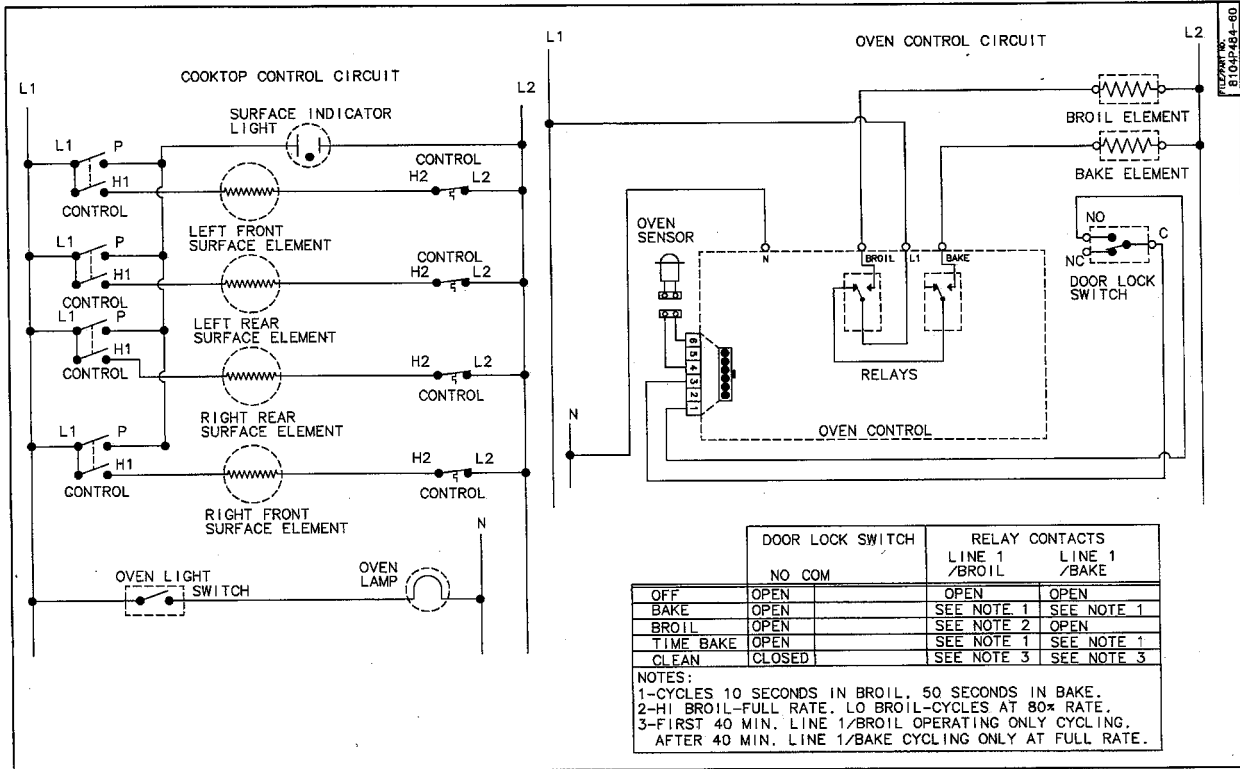
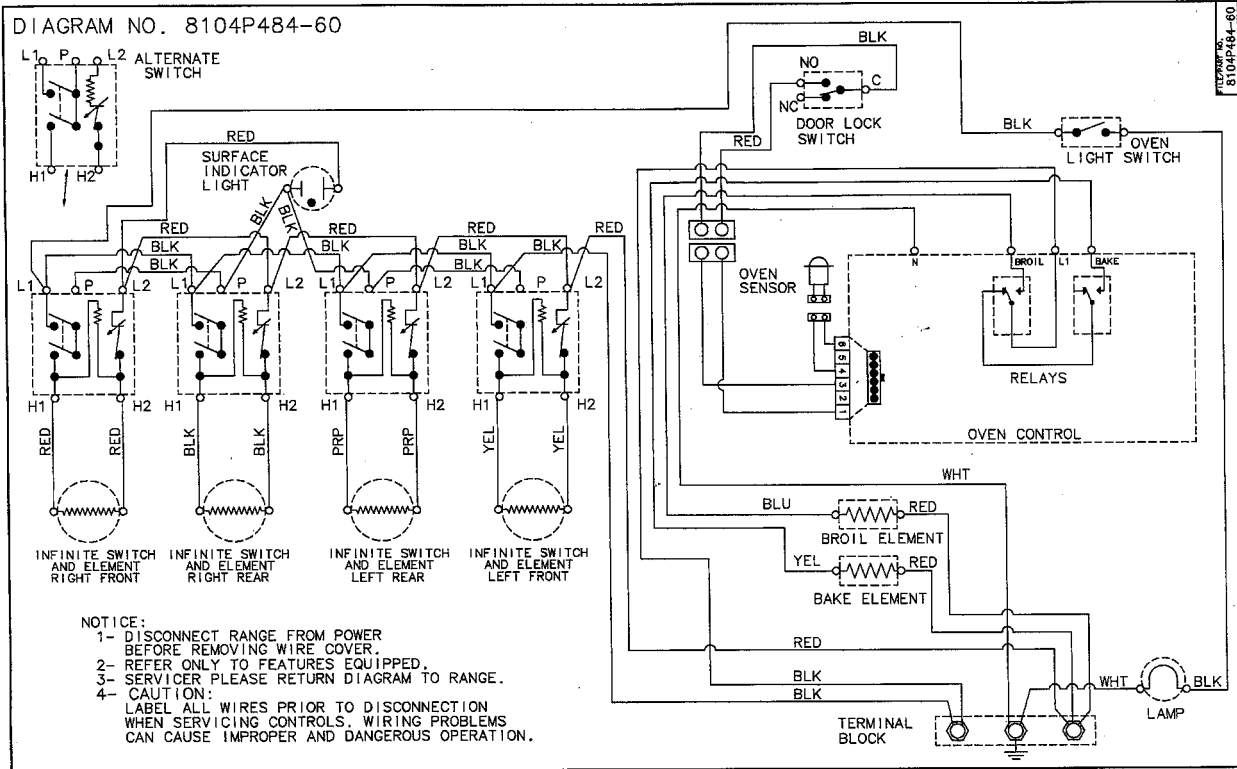

CE38700AAQ CE38700AAV

DIAGRAM NO. 8104P487-60

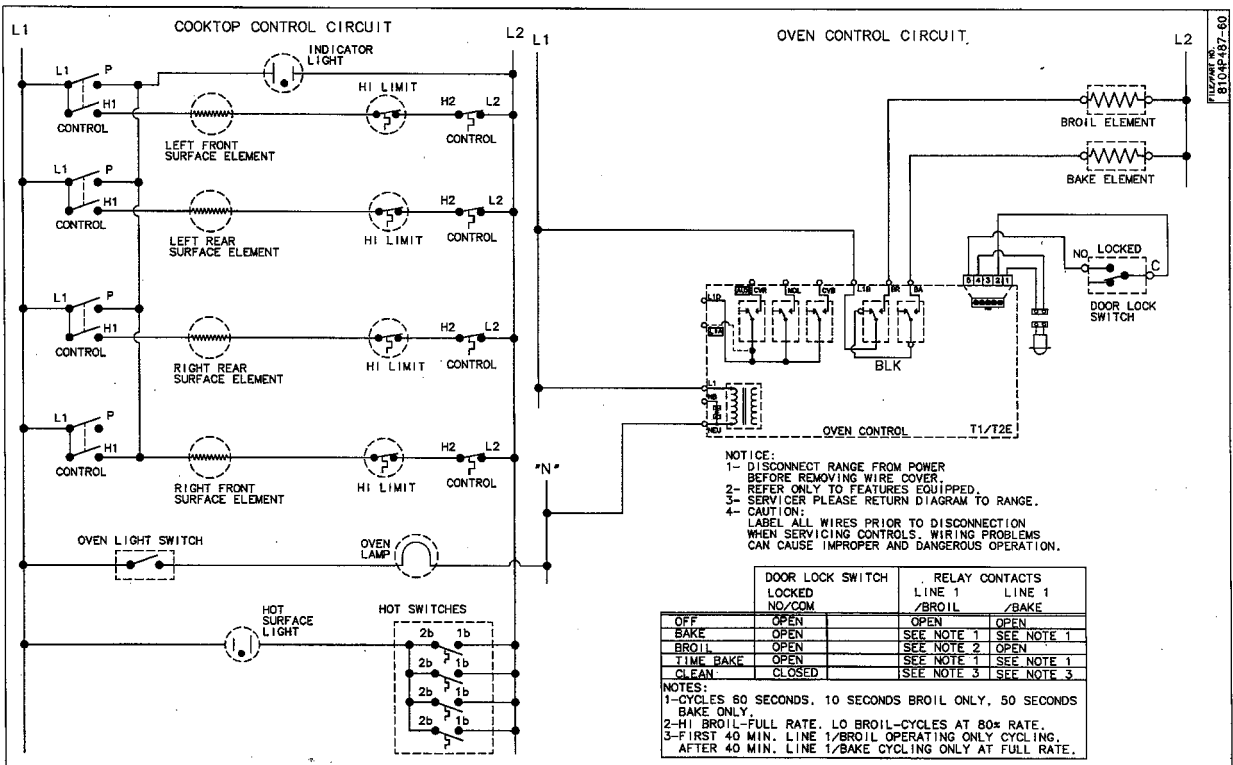
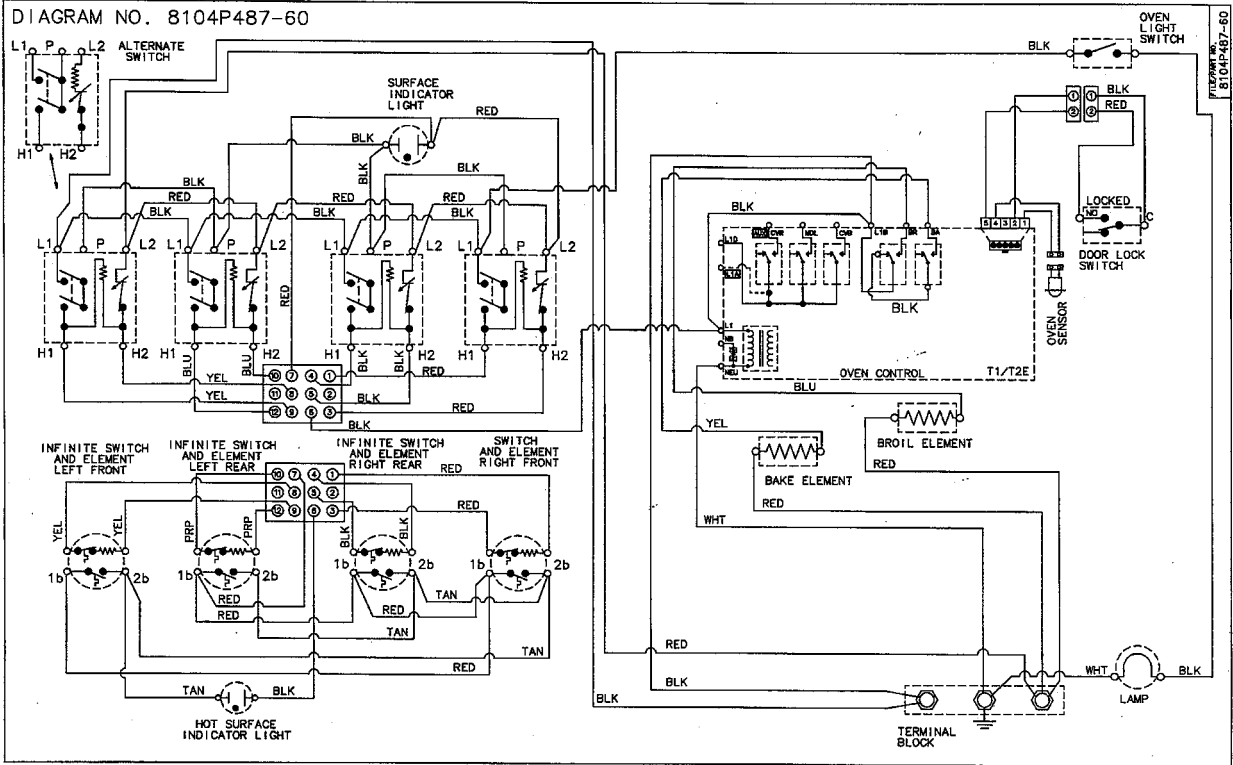



IMPORTANT

Wiring information in this manual was accurate at the time of manual production. Wiring information is subject to change at any time. Please refer to wiring information on the actual product for most current information.

*Because of the simple design of this appliance, wiring is minimal. No engineering diagrams are available. Please refer to information supplied with the unit.

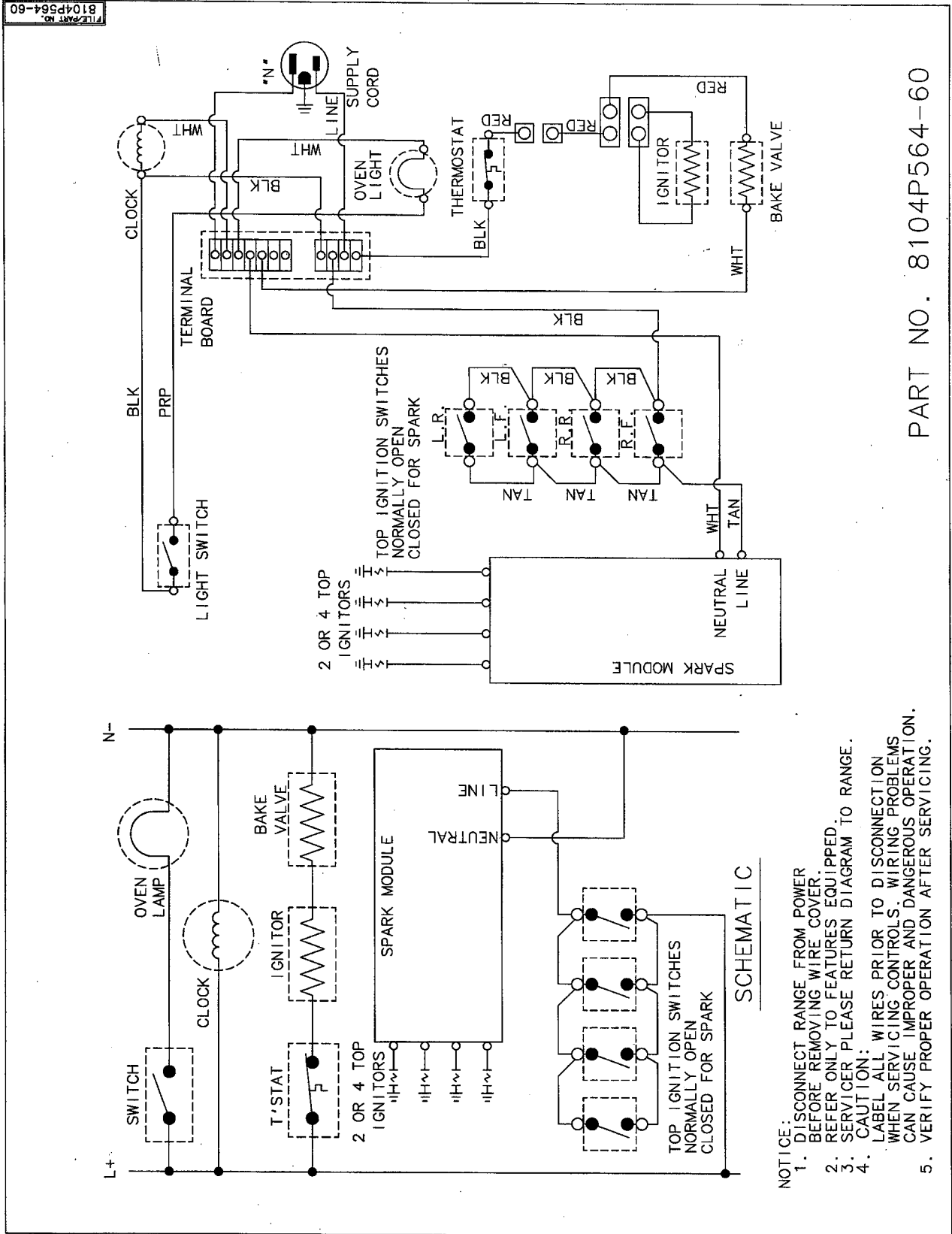

PART NO. 8104P564-60

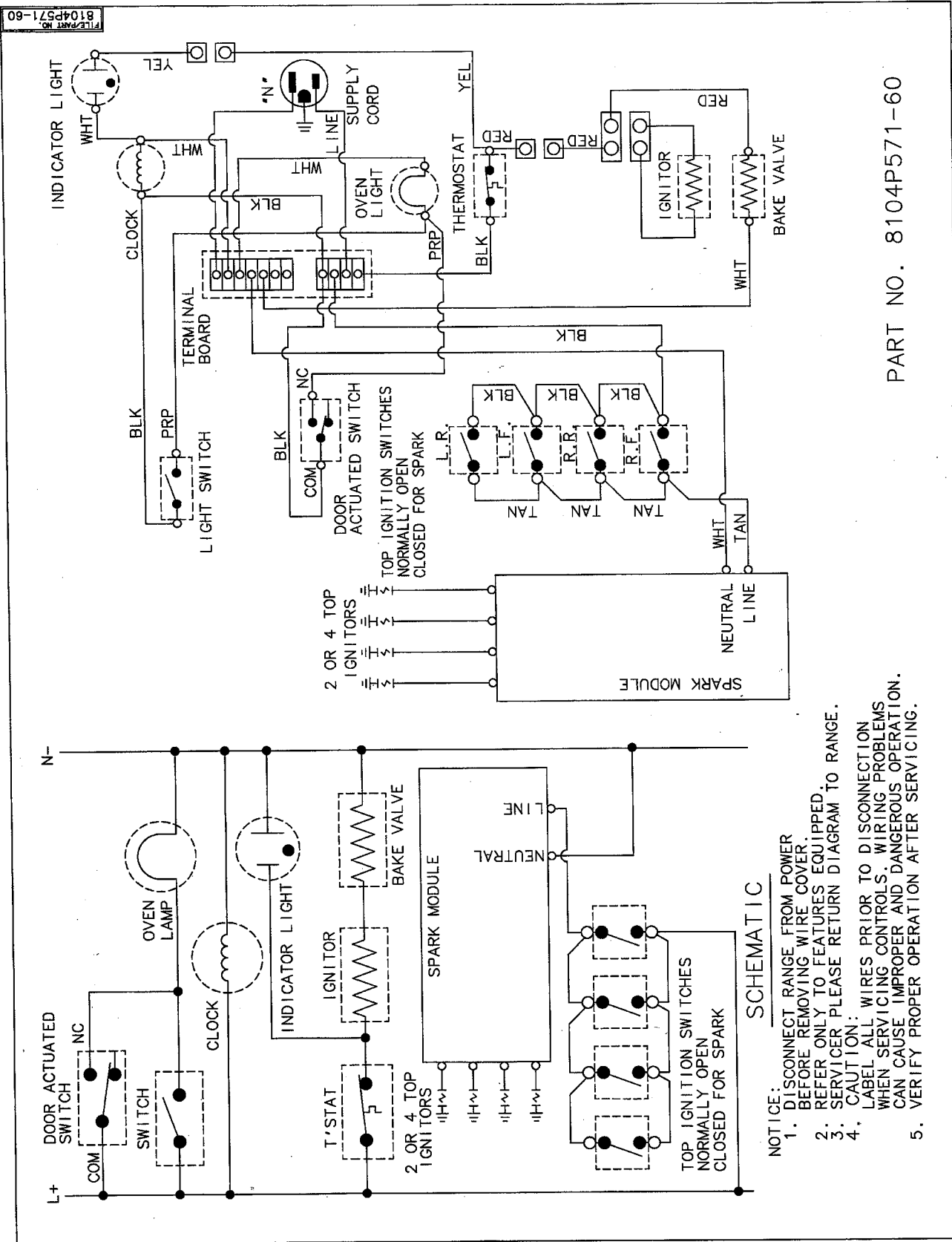

PART NO. 8104P571-60

SCHEMATIC

- NOTICE:**
1. DISCONNECT RANGE FROM POWER BEFORE REMOVING WIRE COVER.
 2. REFER ONLY TO FEATURES EQUIPPED.
 3. SERVICER PLEASE RETURN DIAGRAM TO RANGE.
 4. CAUTION: LABEL ALL WIRES PRIOR TO DISCONNECTION WHEN SERVICING CONTROLS. WIRING PROBLEMS CAN CAUSE IMPROPER AND DANGEROUS OPERATION.
 5. VERIFY PROPER OPERATION AFTER SERVICING.

**MGR5710ADW MGR5720ADH MGR5720ADT MGR5729ADH MGR5729ADQ
MGR5729ADT MGR5729ADW MGR5730ADH MGR5730ADQ MGR5730ADW**

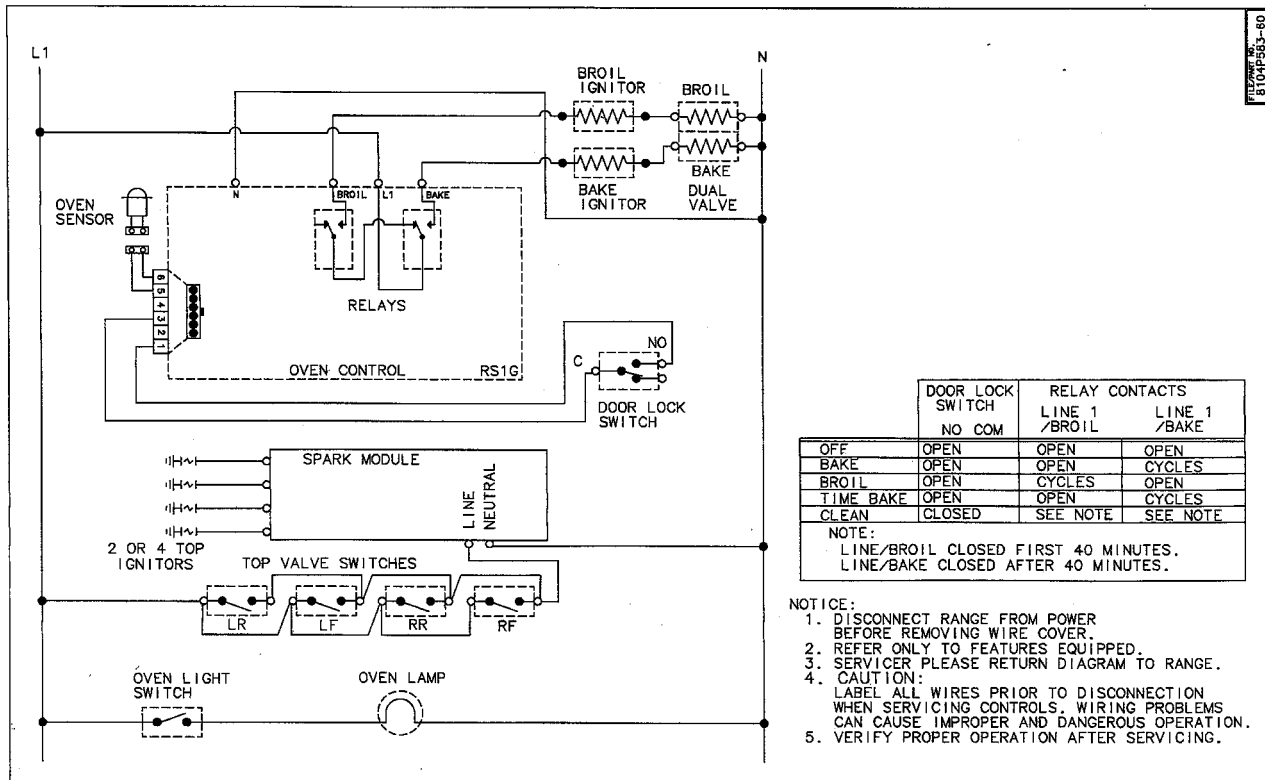
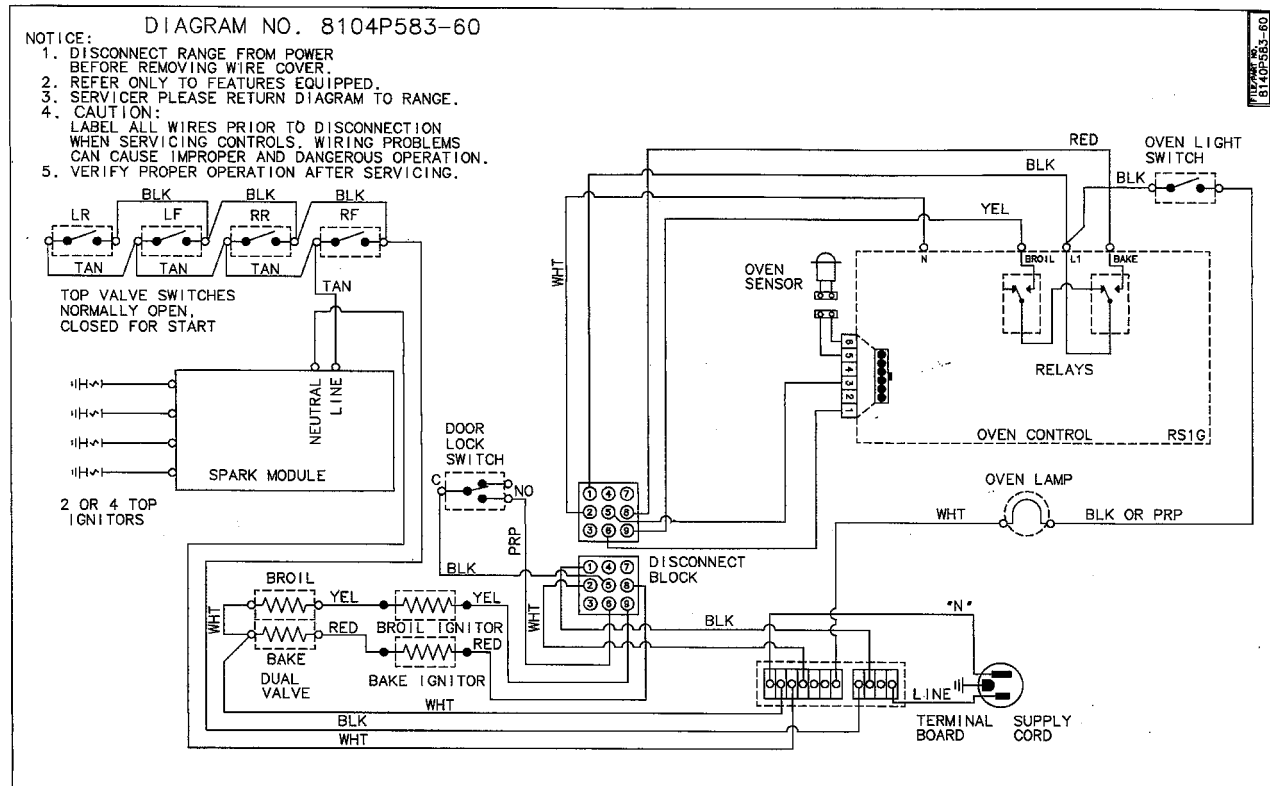

MGR5750ADQ MGR5750ADW

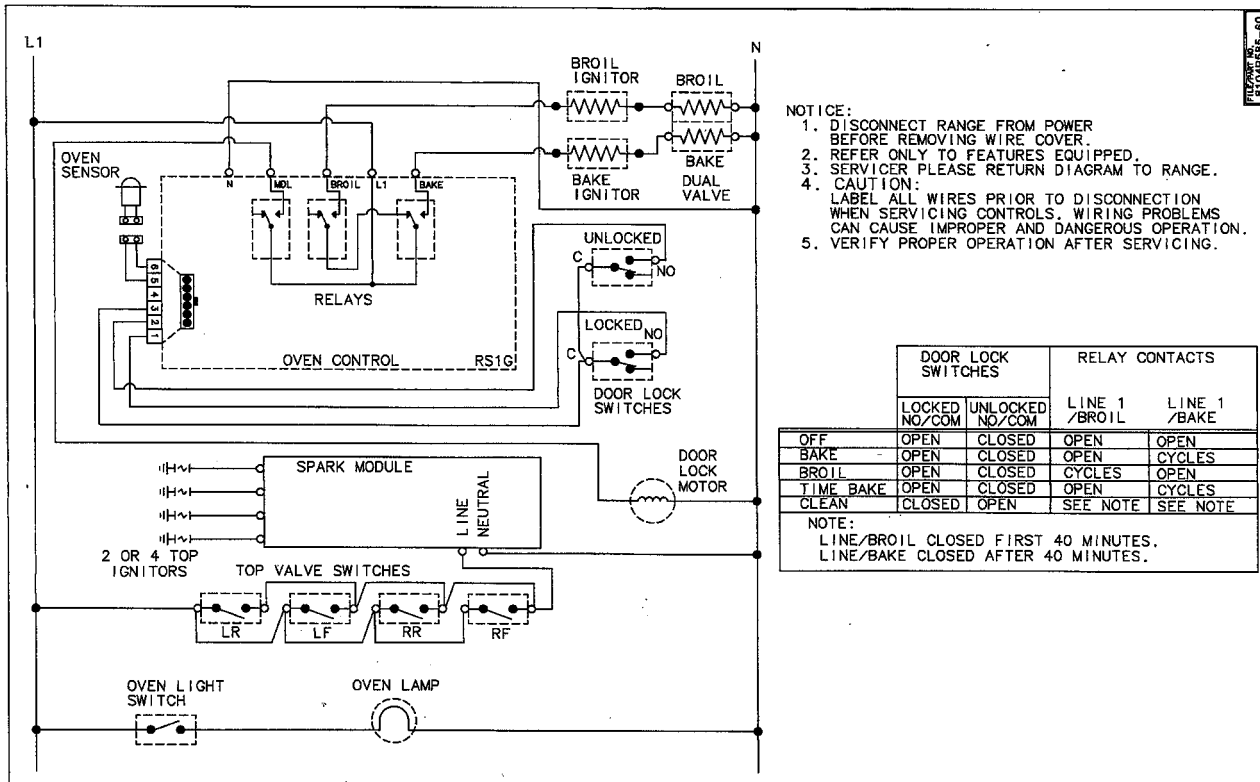
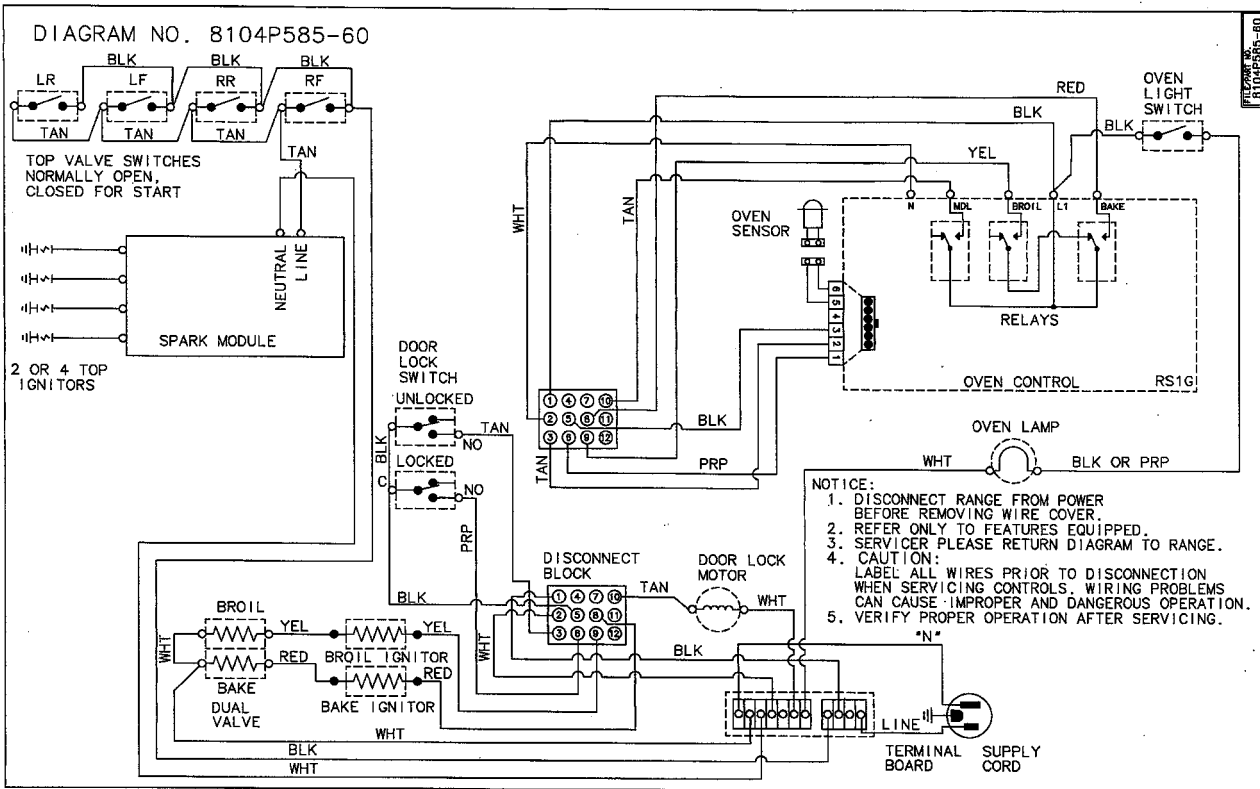

MGR5755ADB MGR5755ADQ MGR5755ADW

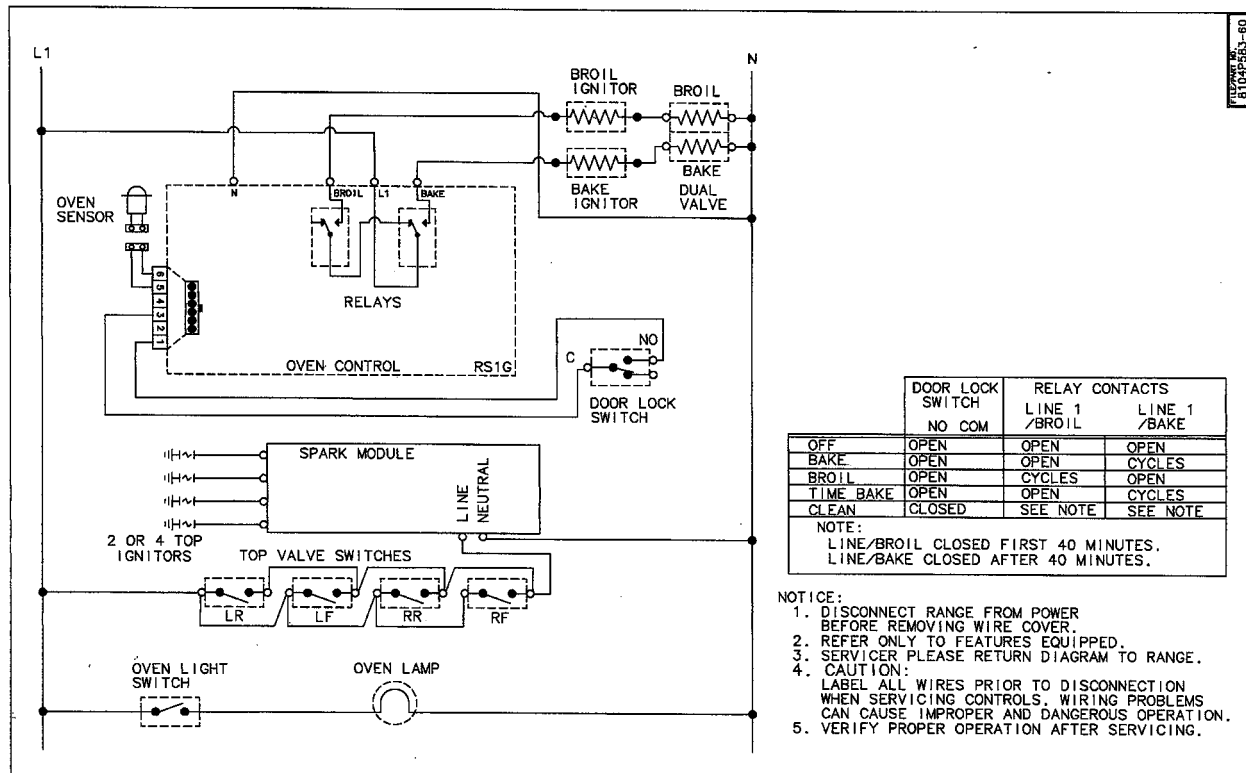
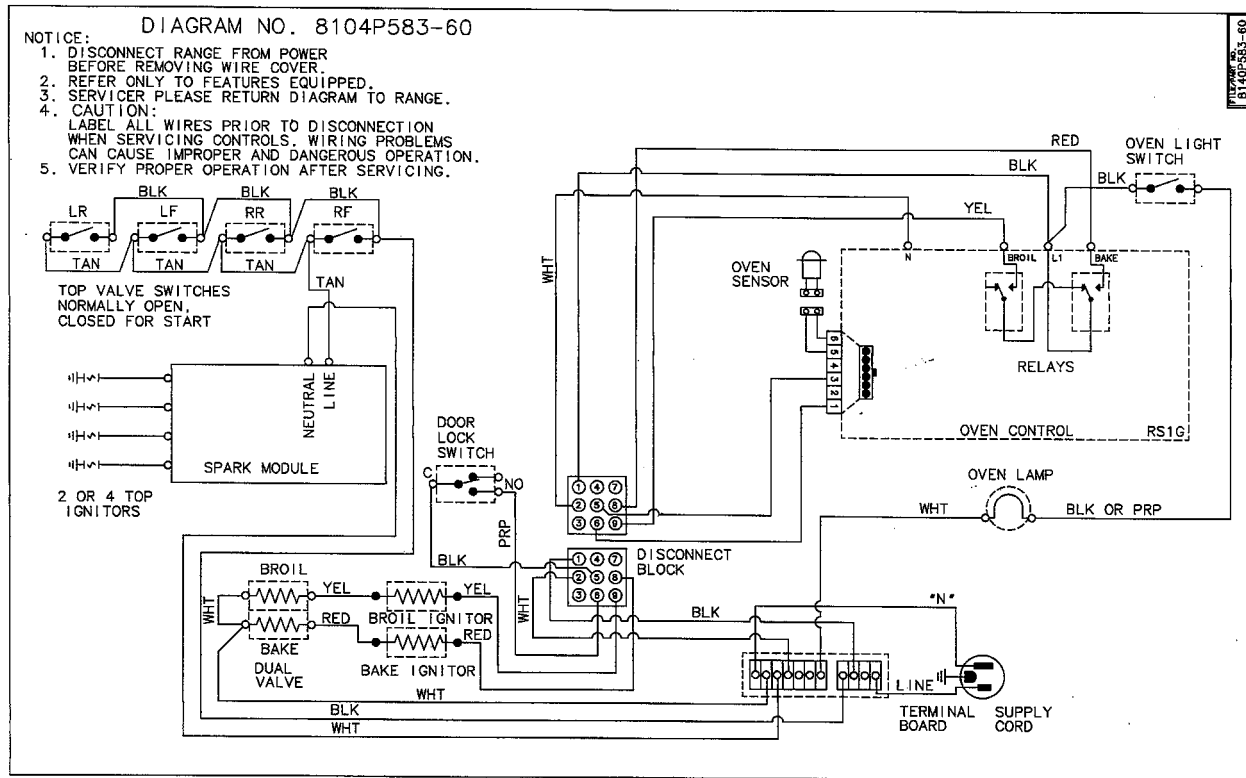

**MGR5770ADB MGR5770ADQ MGR5770ADW MGR5775ADB
MGR5775ADQMGR5775ADW MGR5870ADB MGR5870ADQ MGR5870ADW**

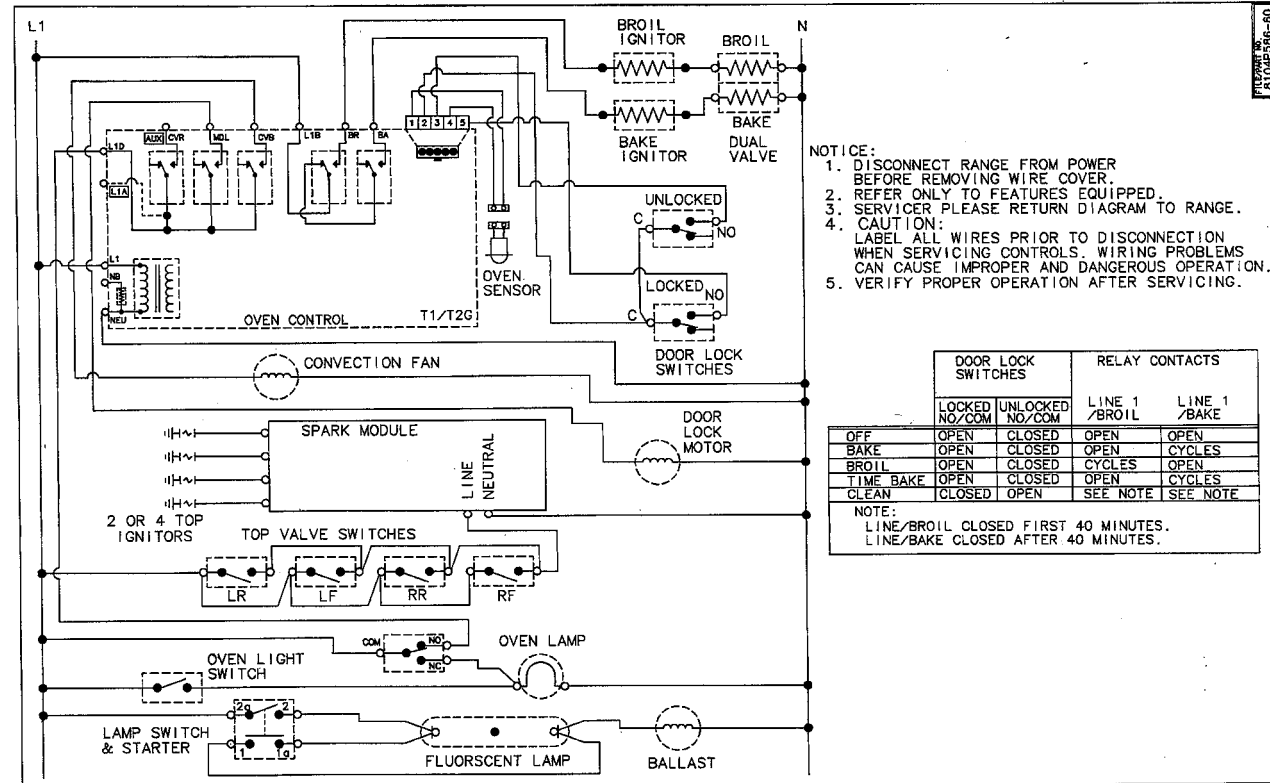
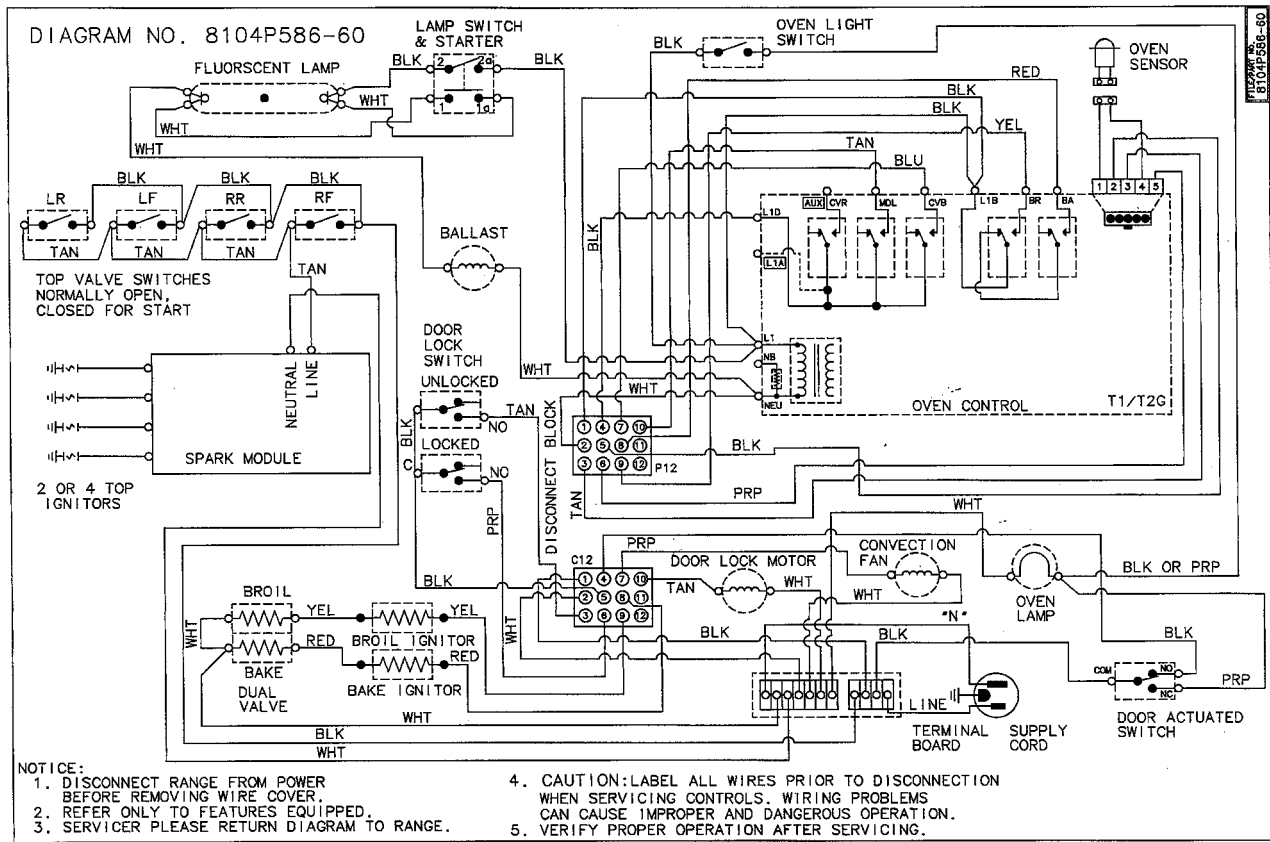

MEP5770AAB MEP5770AAW

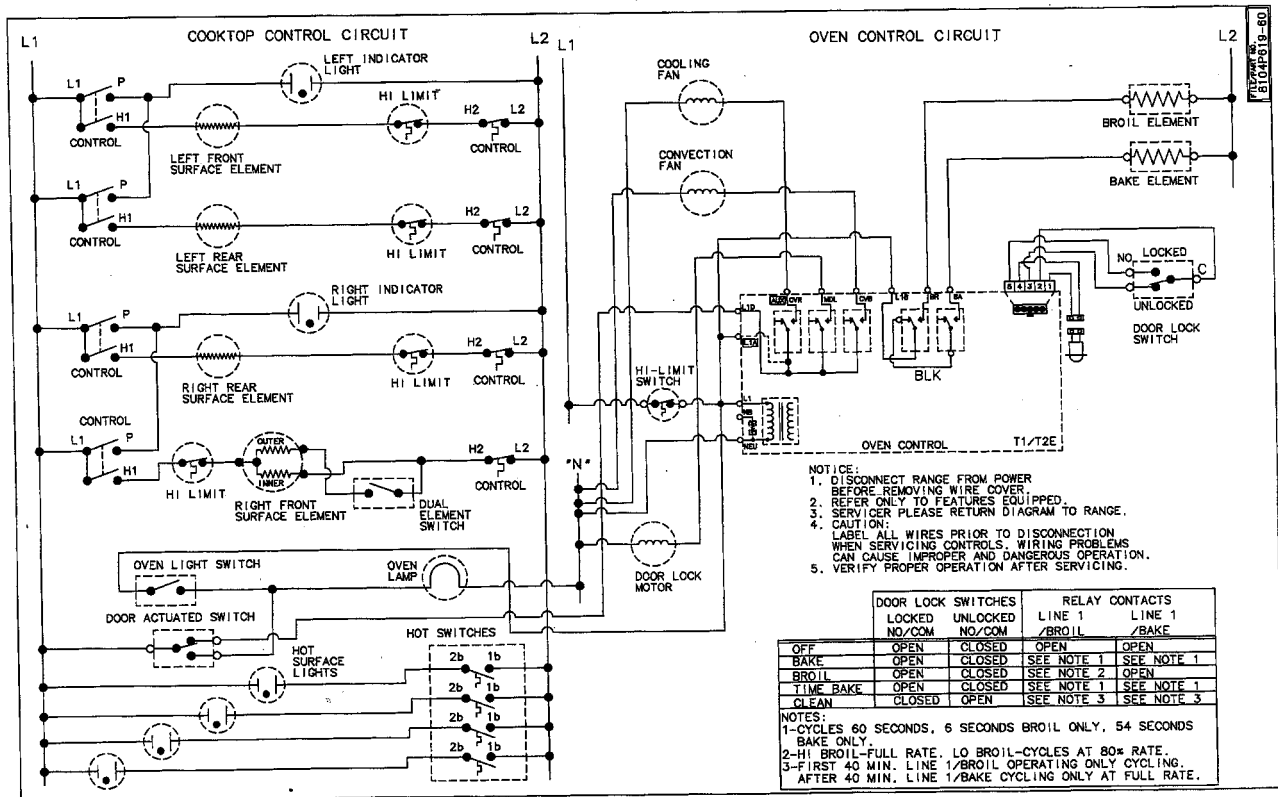
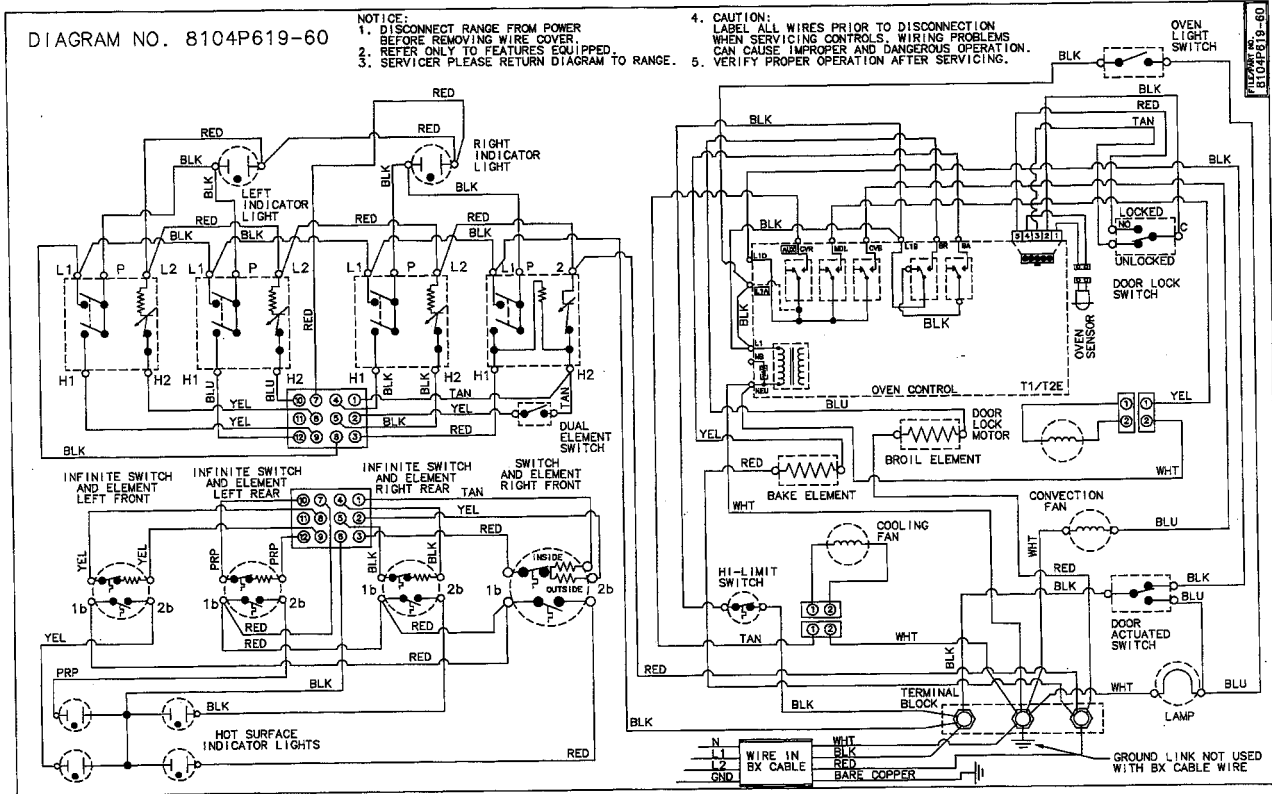

MER4110AAW

DIAGRAM NO. 8104P552-60

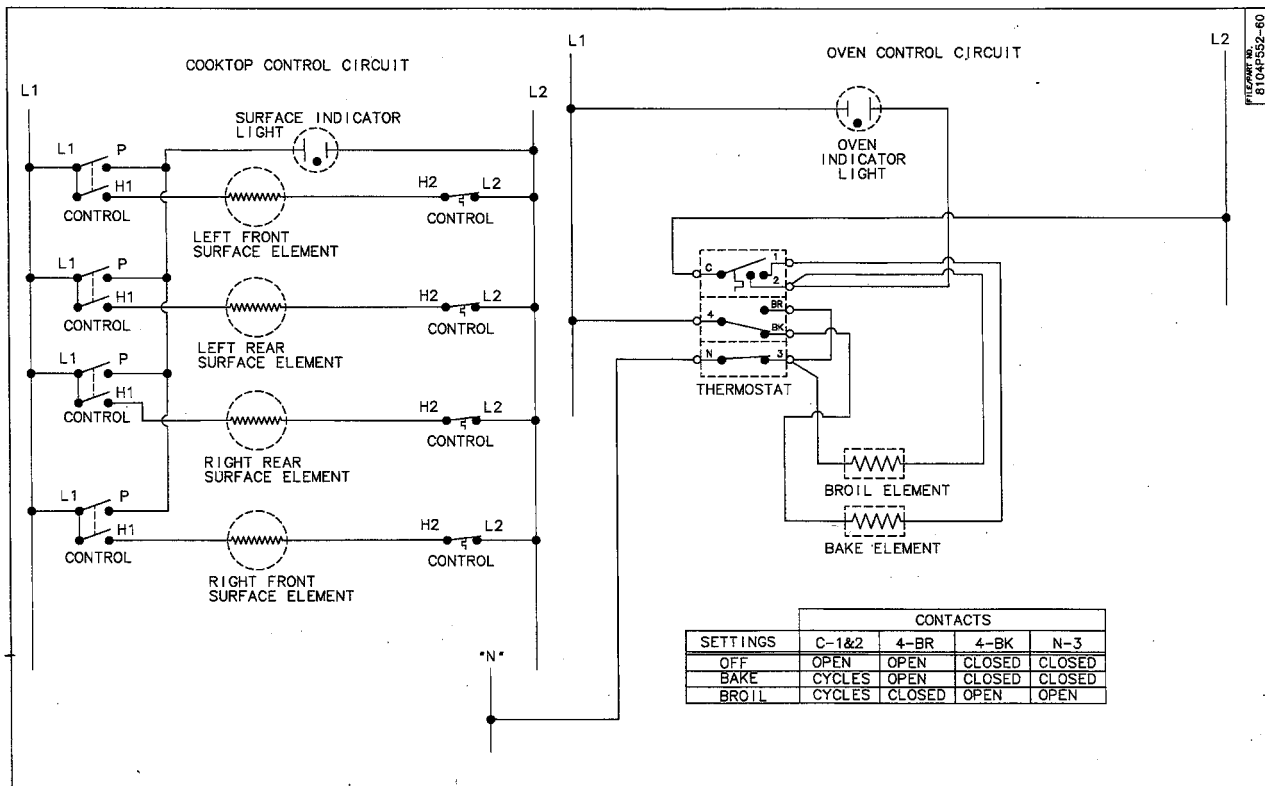
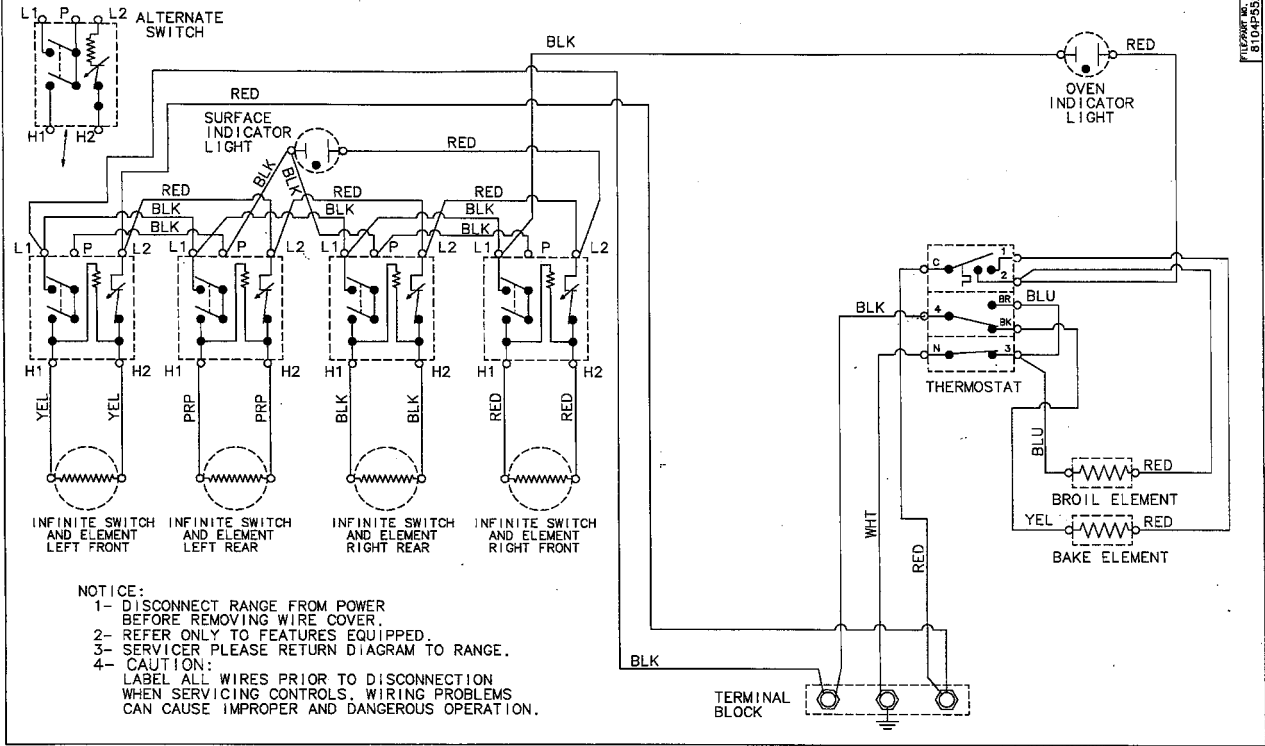

MER4320AAW

DIAGRAM NO. 8104P554-60

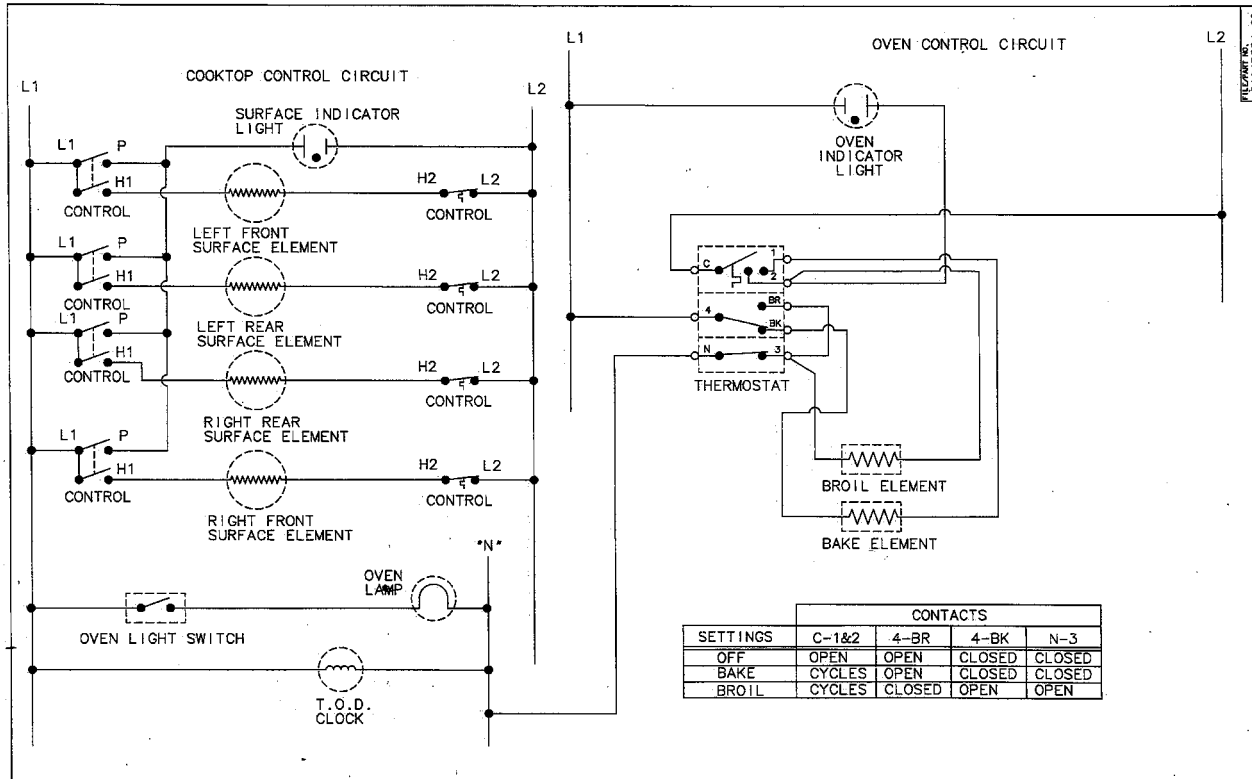
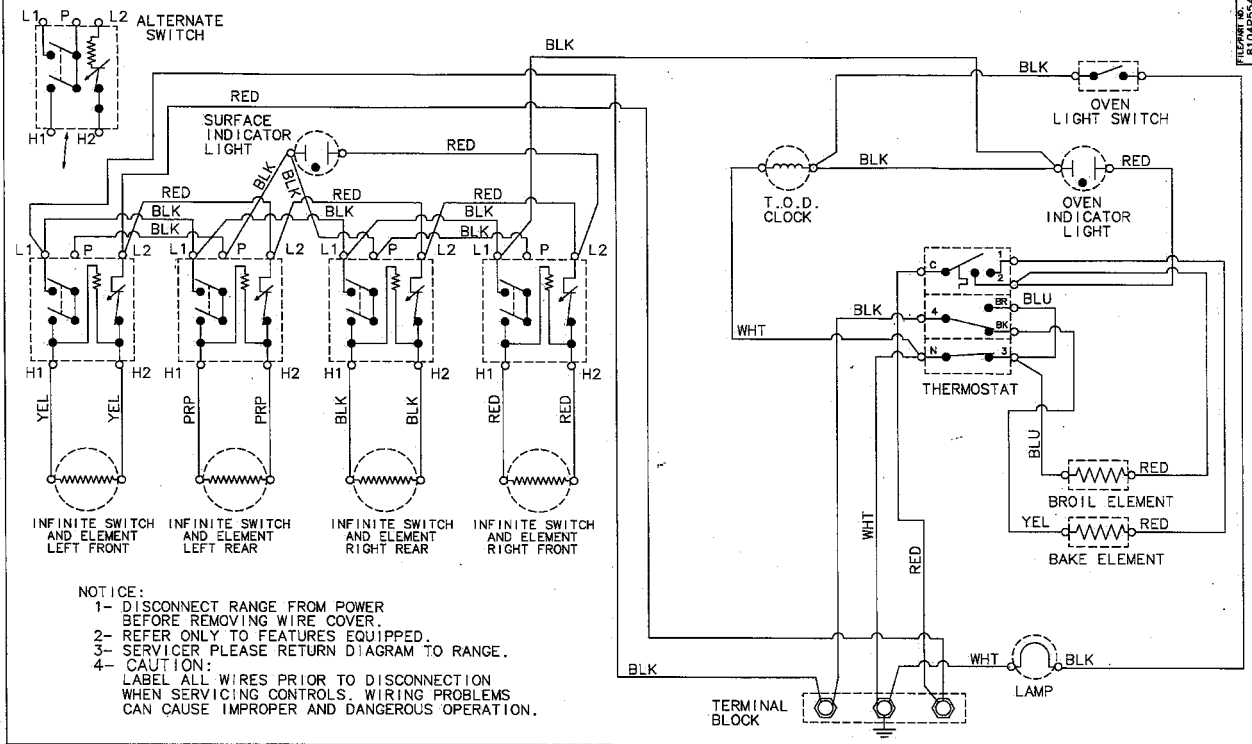

MER4530AAQ MER4530AAW

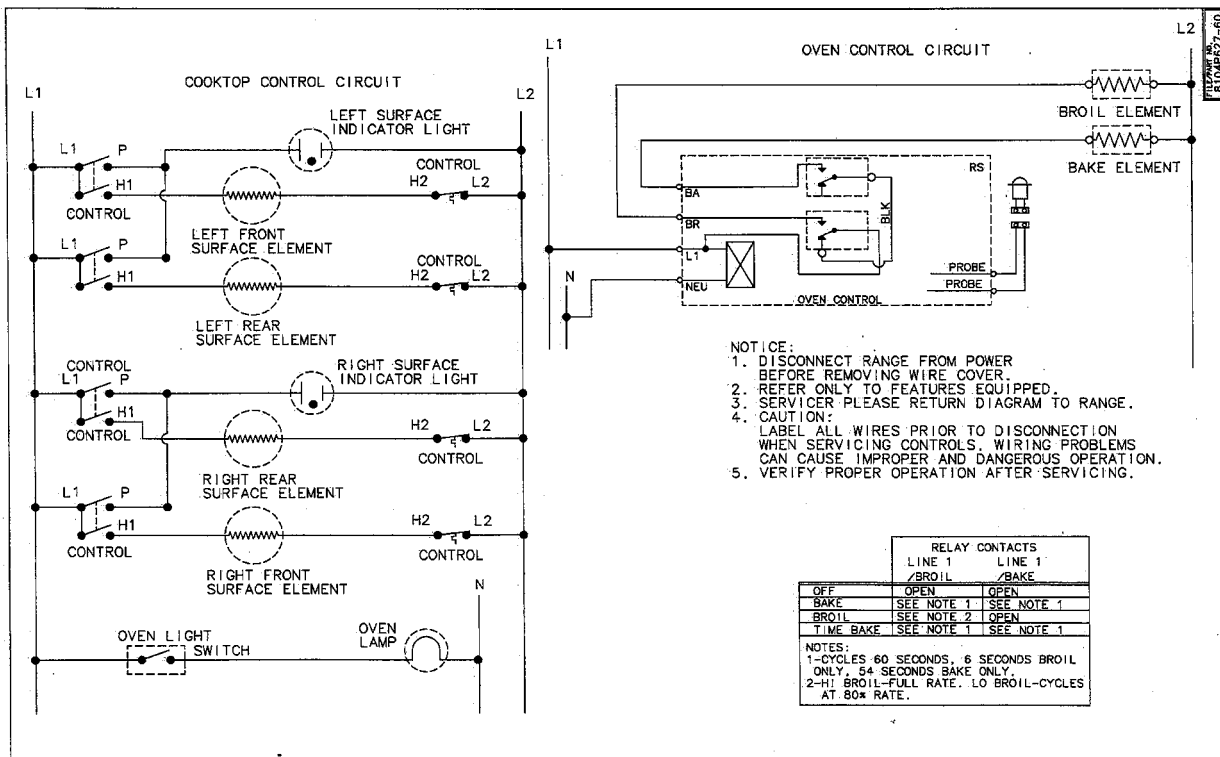
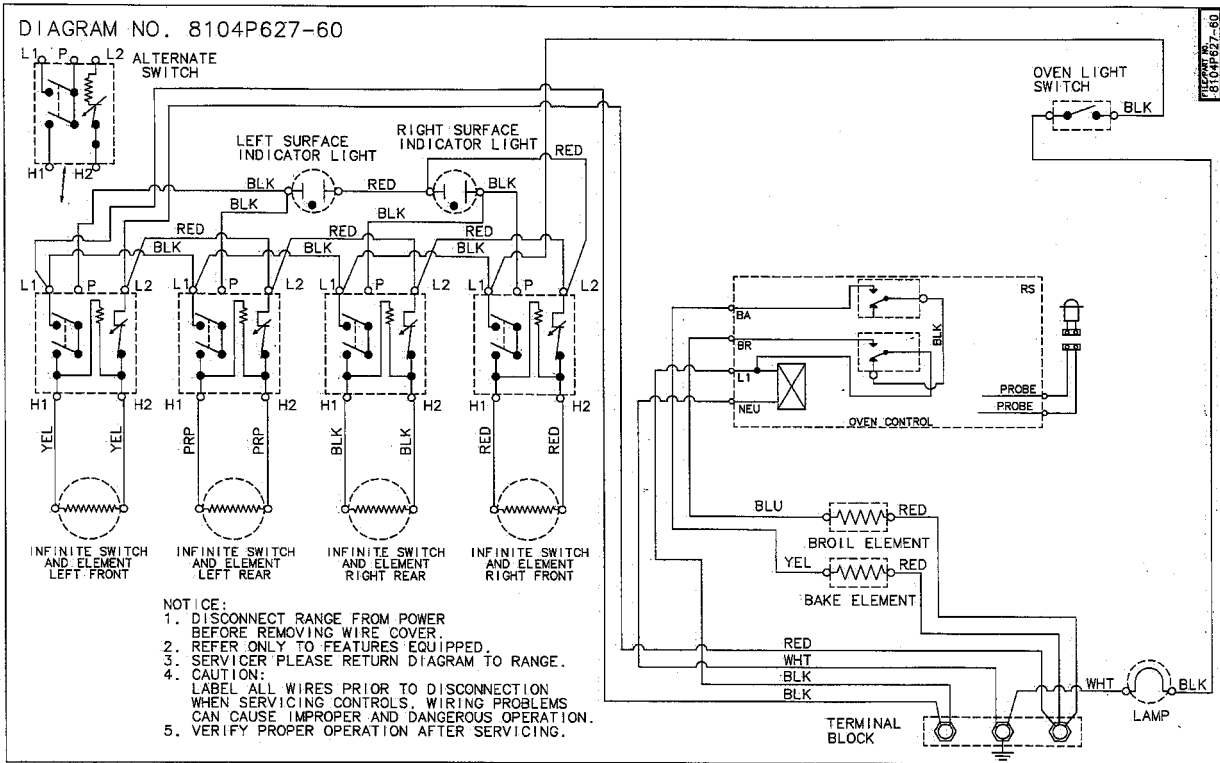

MER4530BCW

DIAGRAM NO. 8104P683-60

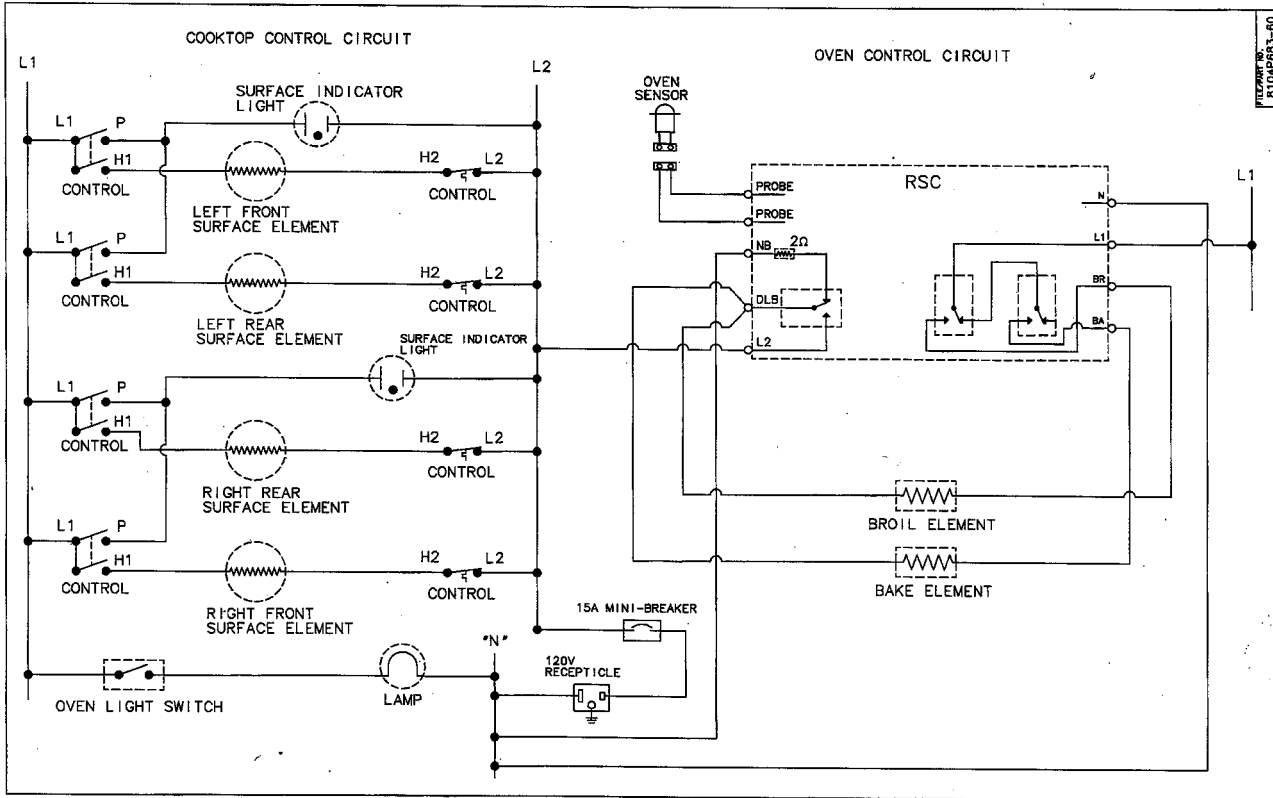
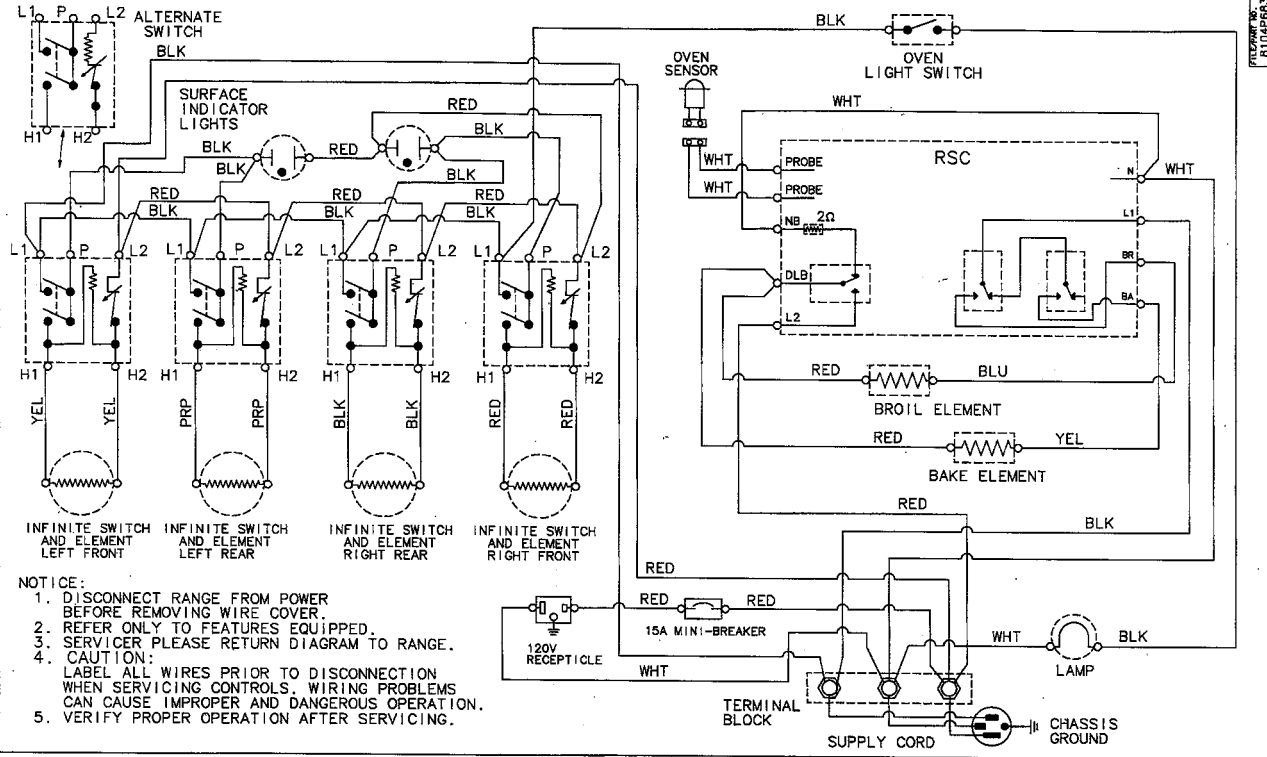

MER5510AAT MER5510AAT

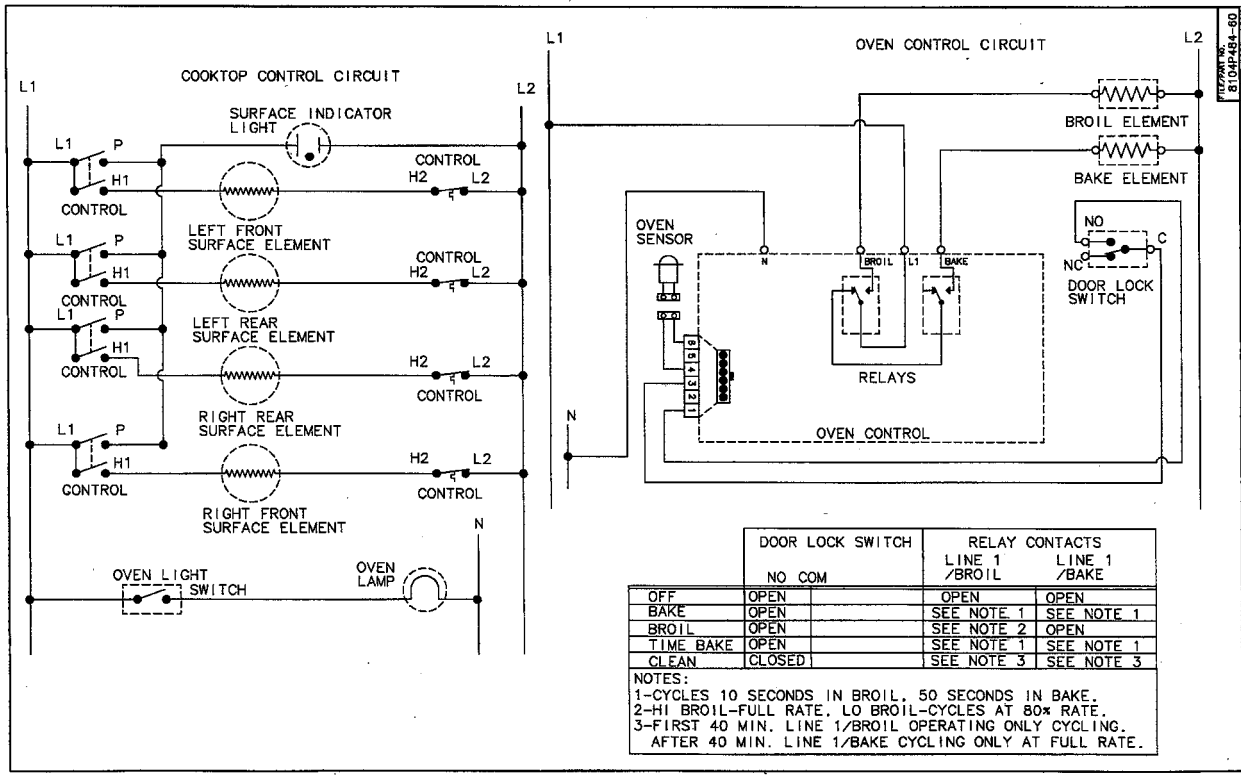
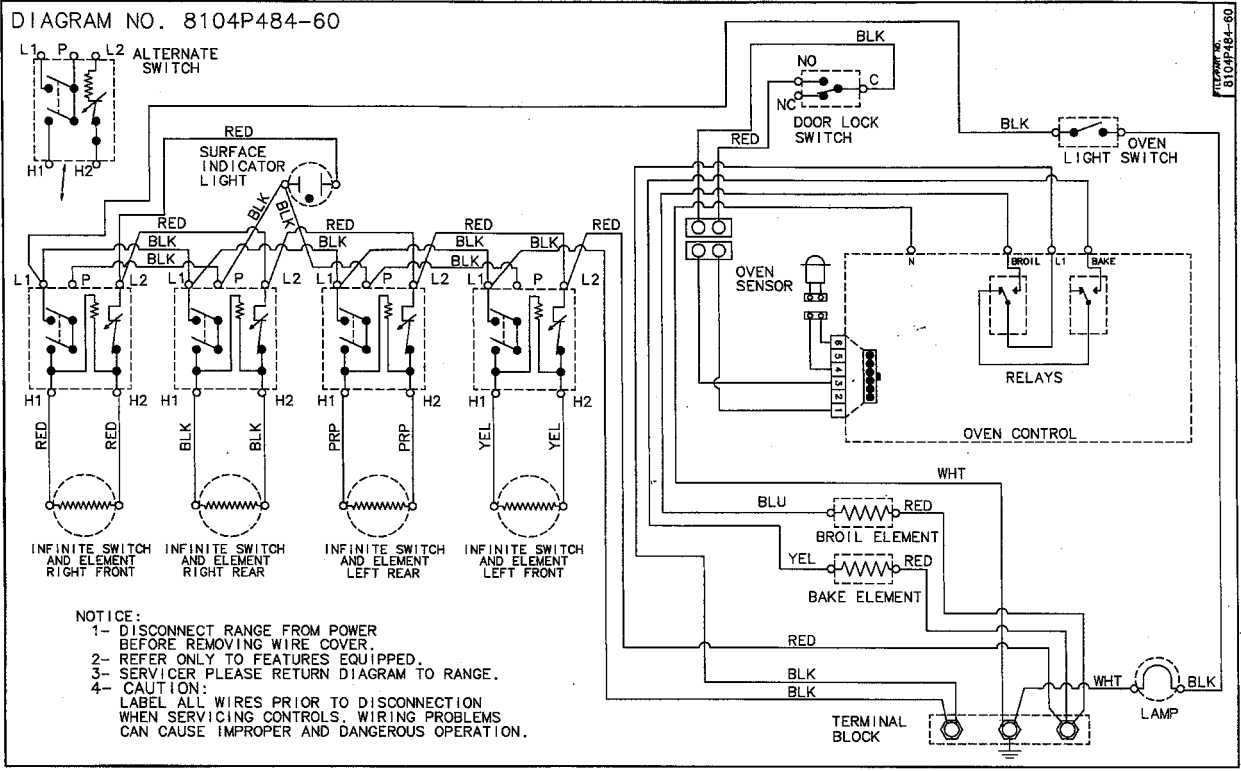

MER5530AAH MER5530AAW MER5530AAW

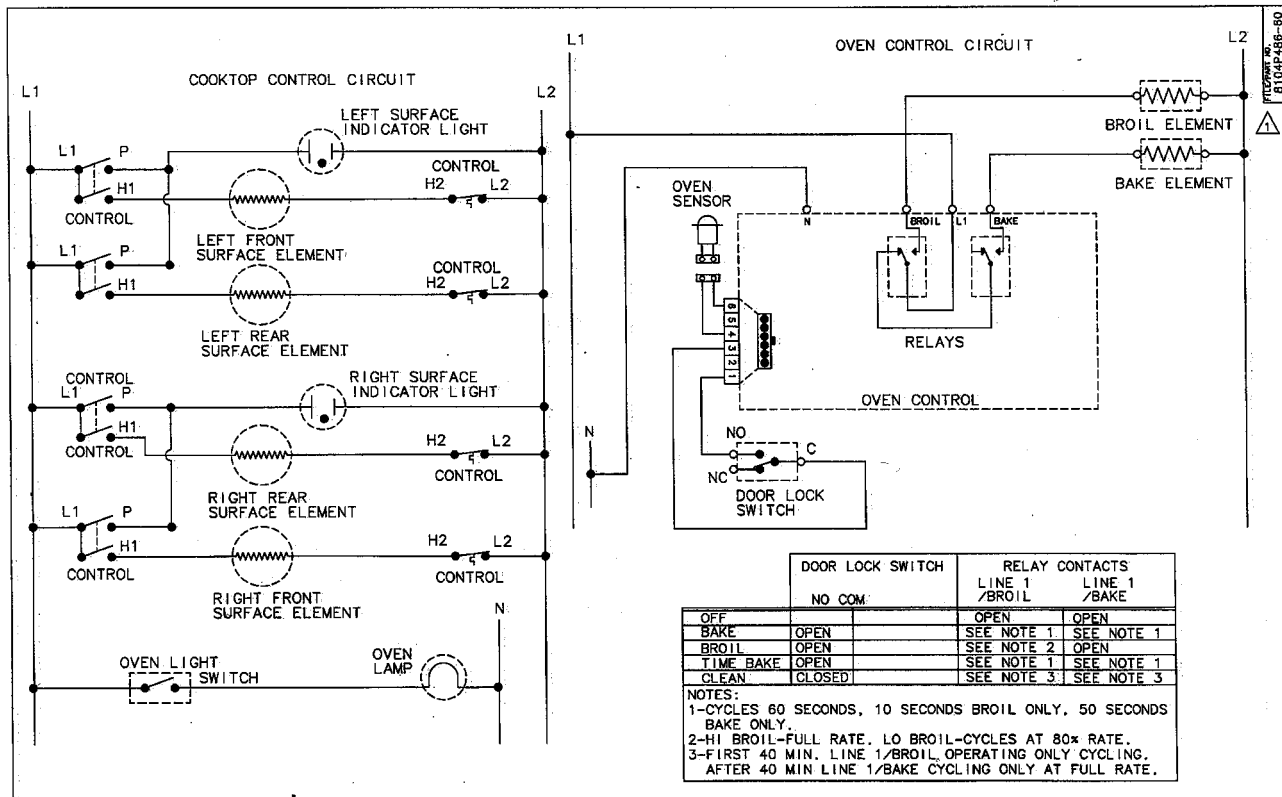
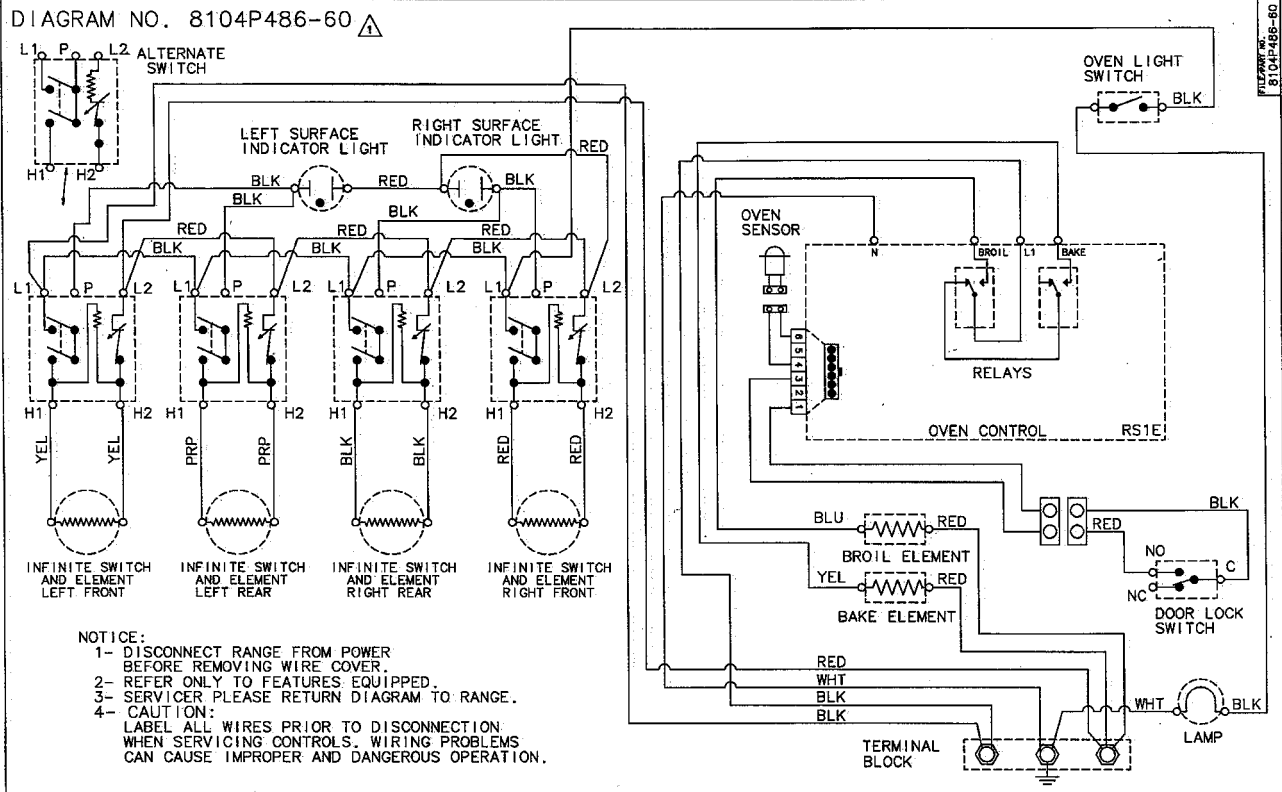

MER530ACW

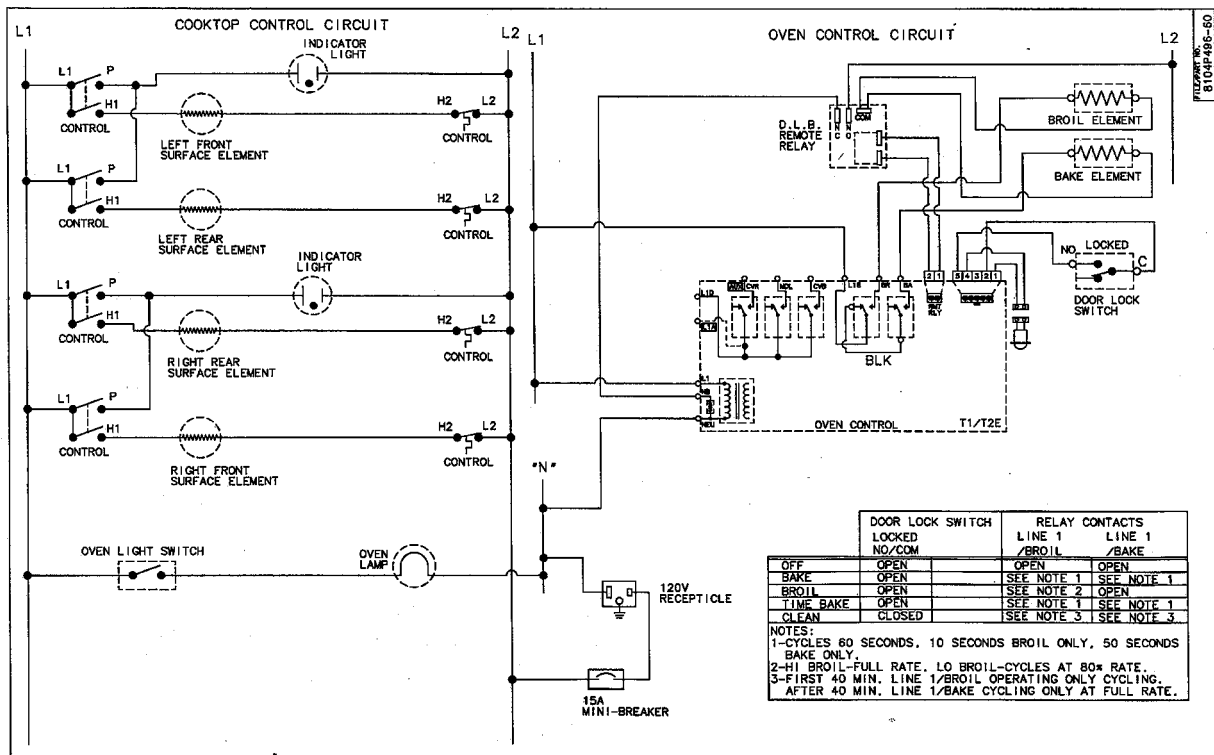
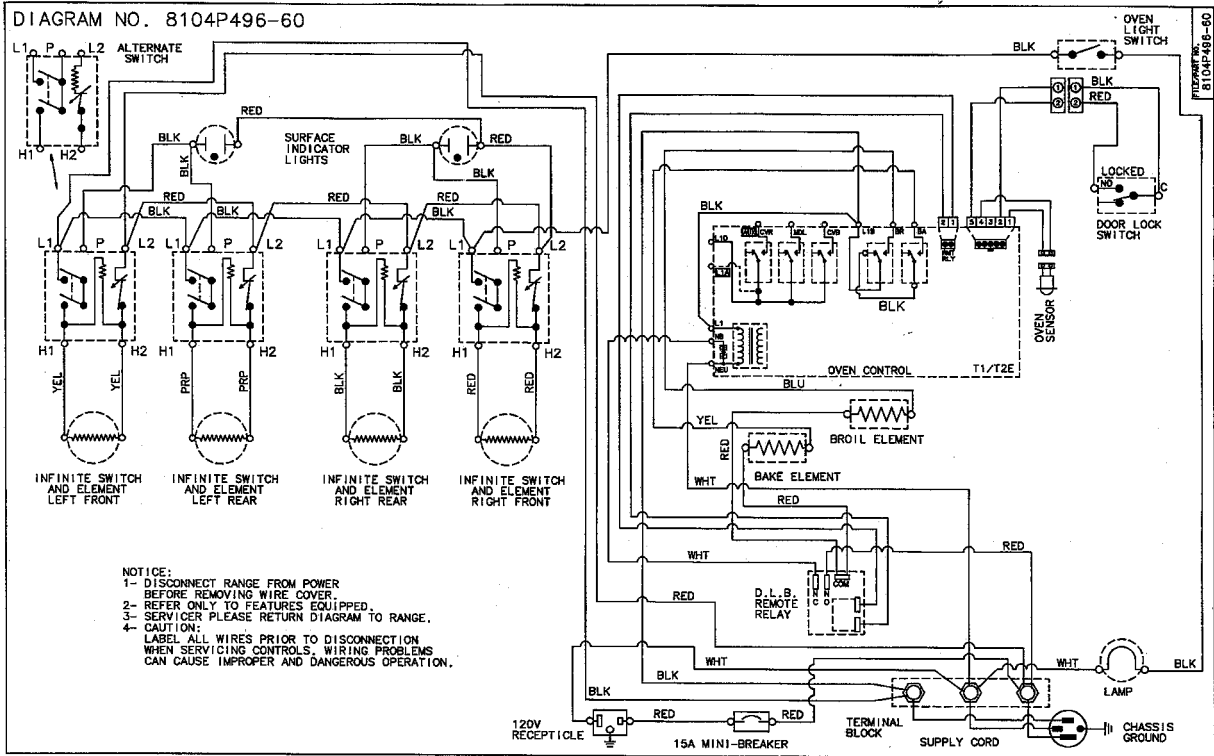

MER550AAH MER550AAQ MER550AAW

DIAGRAM NO. 8104P524-60

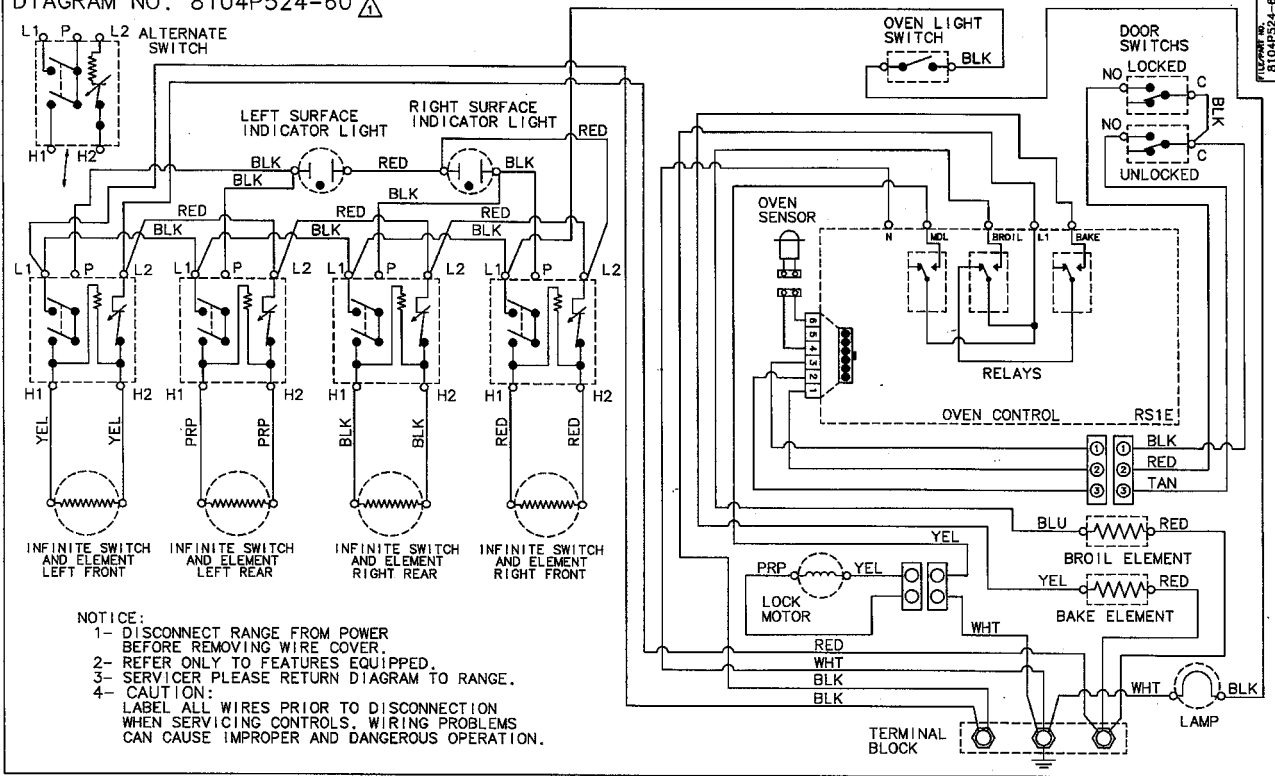

NOTICE:
 1- DISCONNECT RANGE FROM POWER BEFORE REMOVING WIRE COVER.
 2- REFER ONLY TO FEATURES EQUIPPED.
 3- SERVICER PLEASE RETURN DIAGRAM TO RANGE.
 4- CAUTION: LABEL ALL WIRES PRIOR TO DISCONNECTION WHEN SERVICING CONTROLS. WIRING PROBLEMS CAN CAUSE IMPROPER AND DANGEROUS OPERATION.

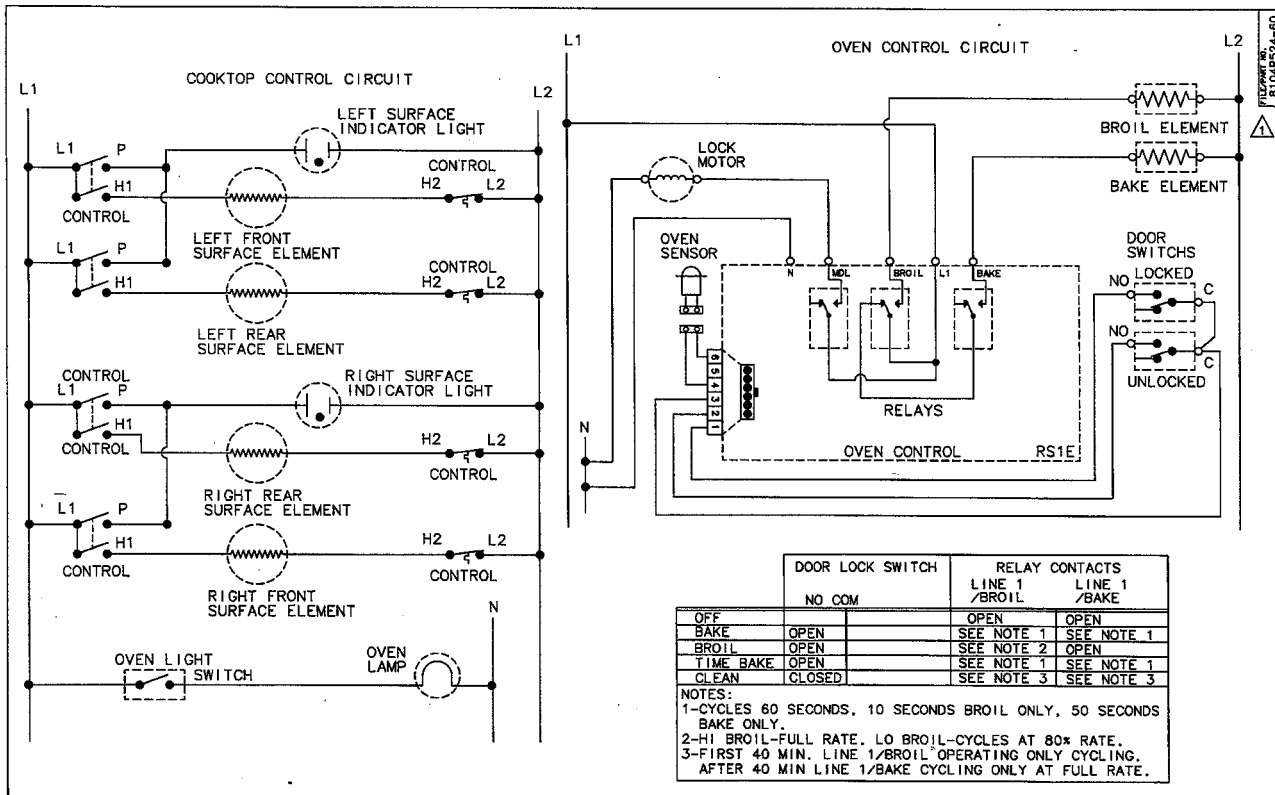

MER5570ACQ MER5570ACW

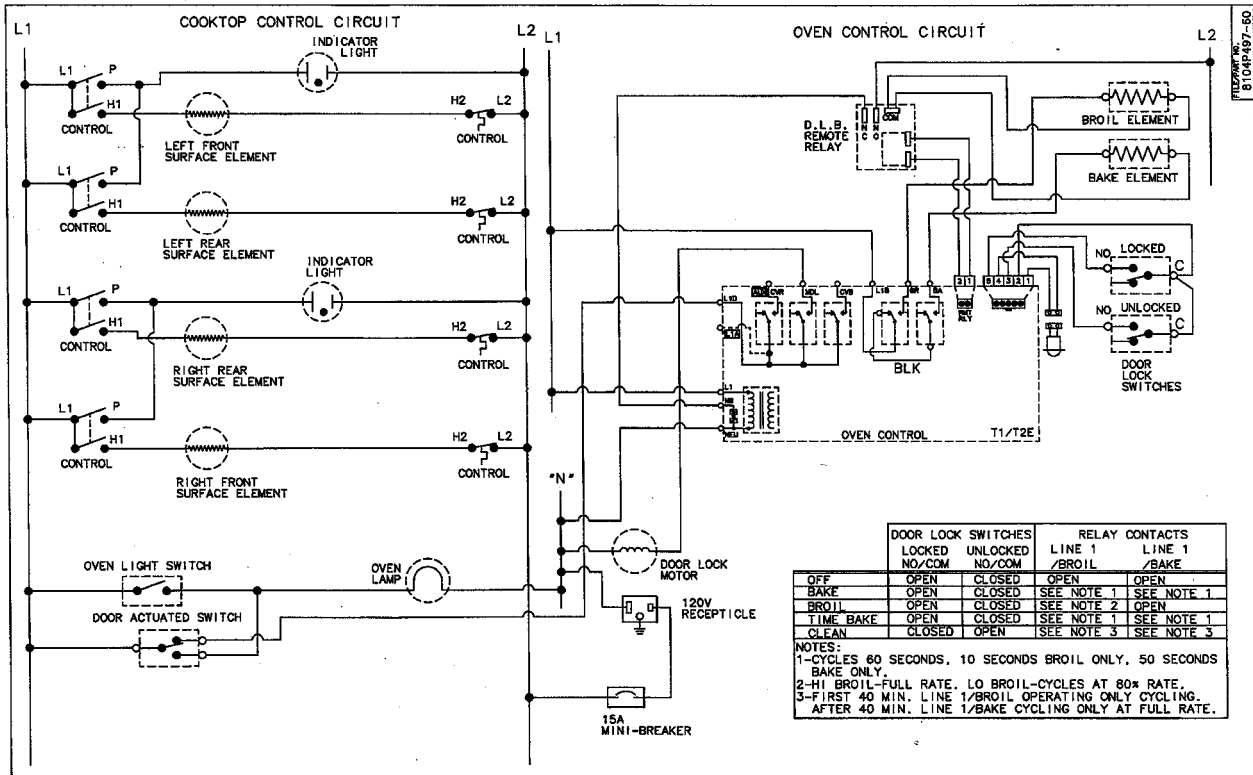
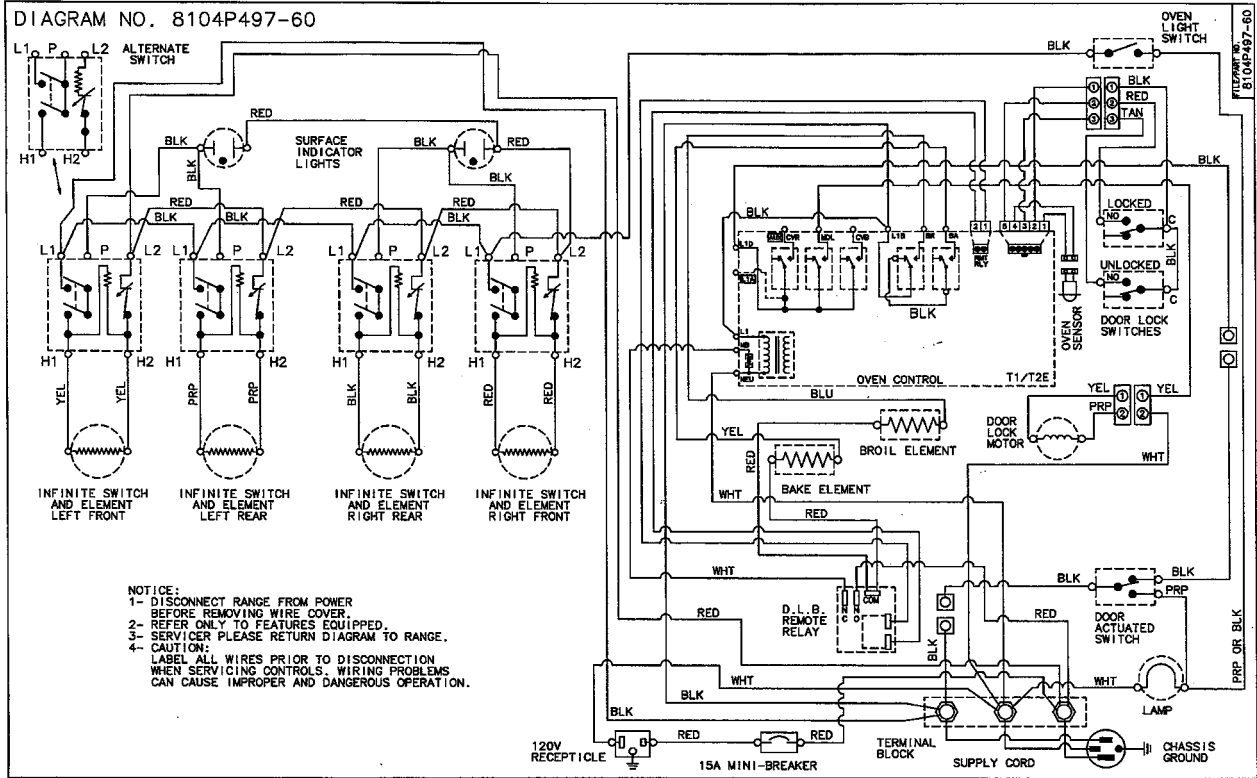

MER5710AAW MER5730AAQ MER5730AAW

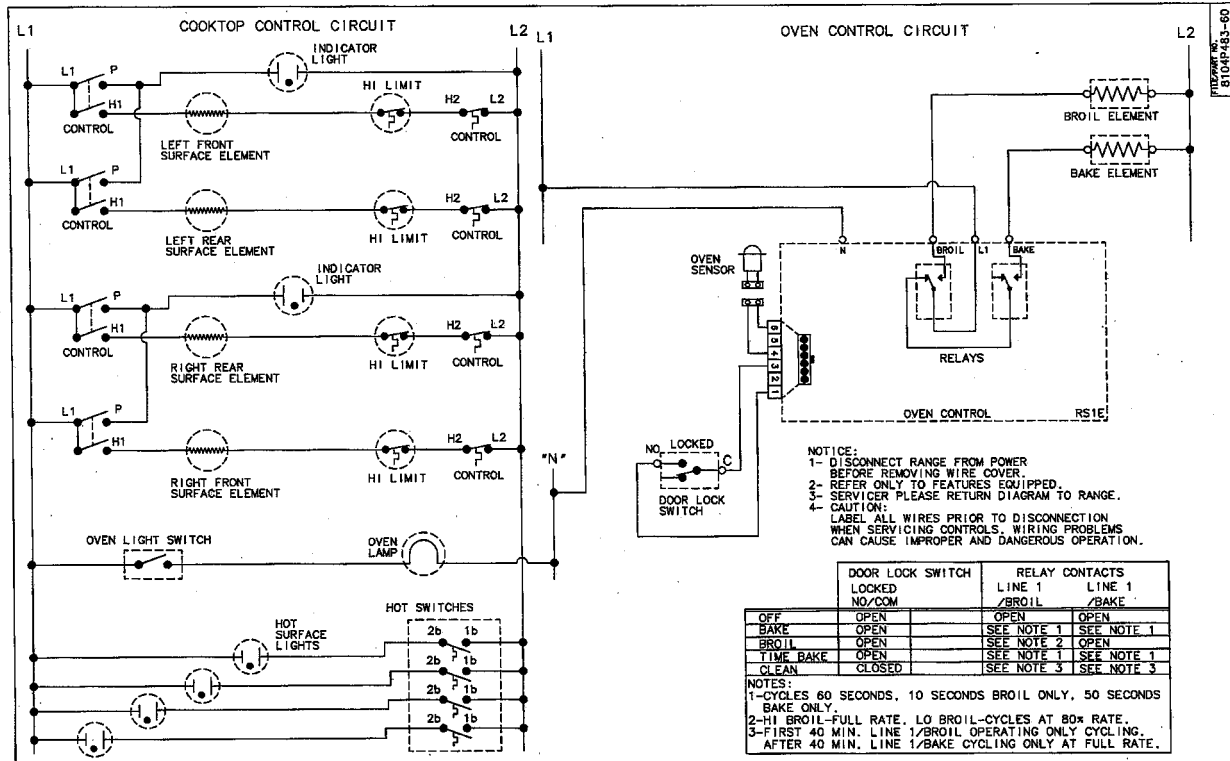
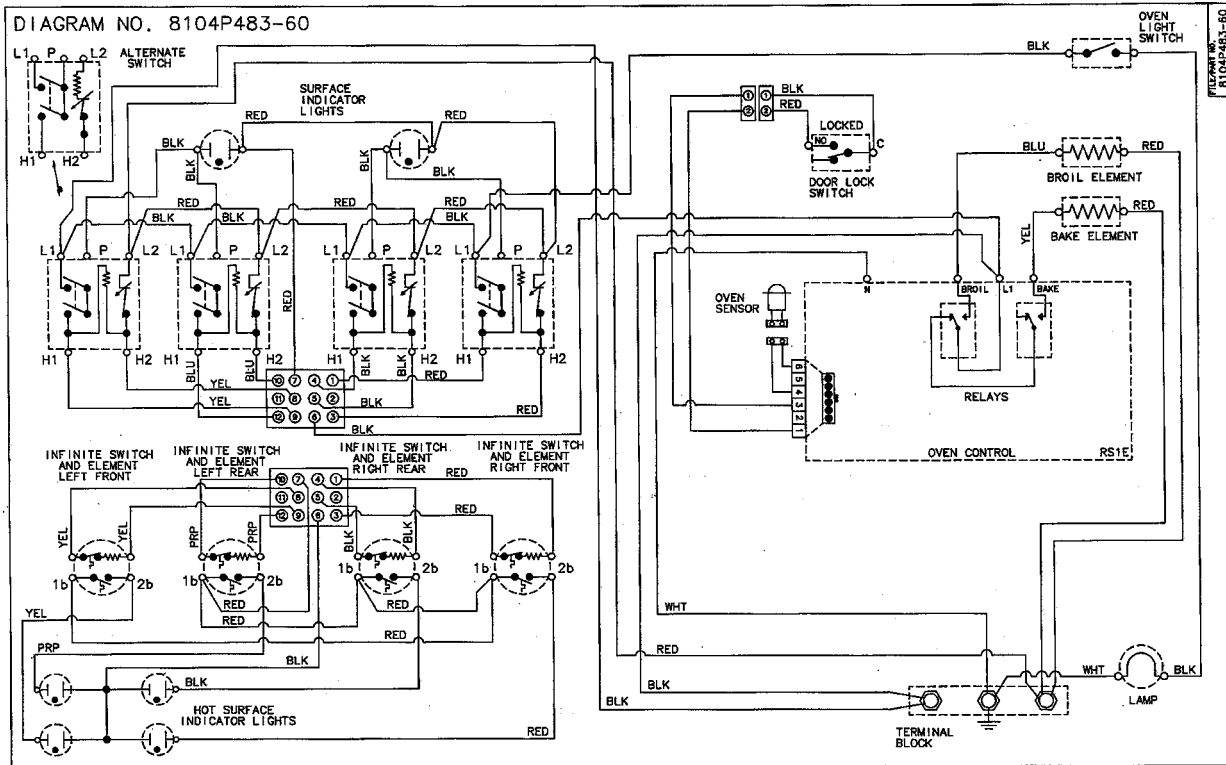

MER5730ACW

DIAGRAM NO. 8104P685-60

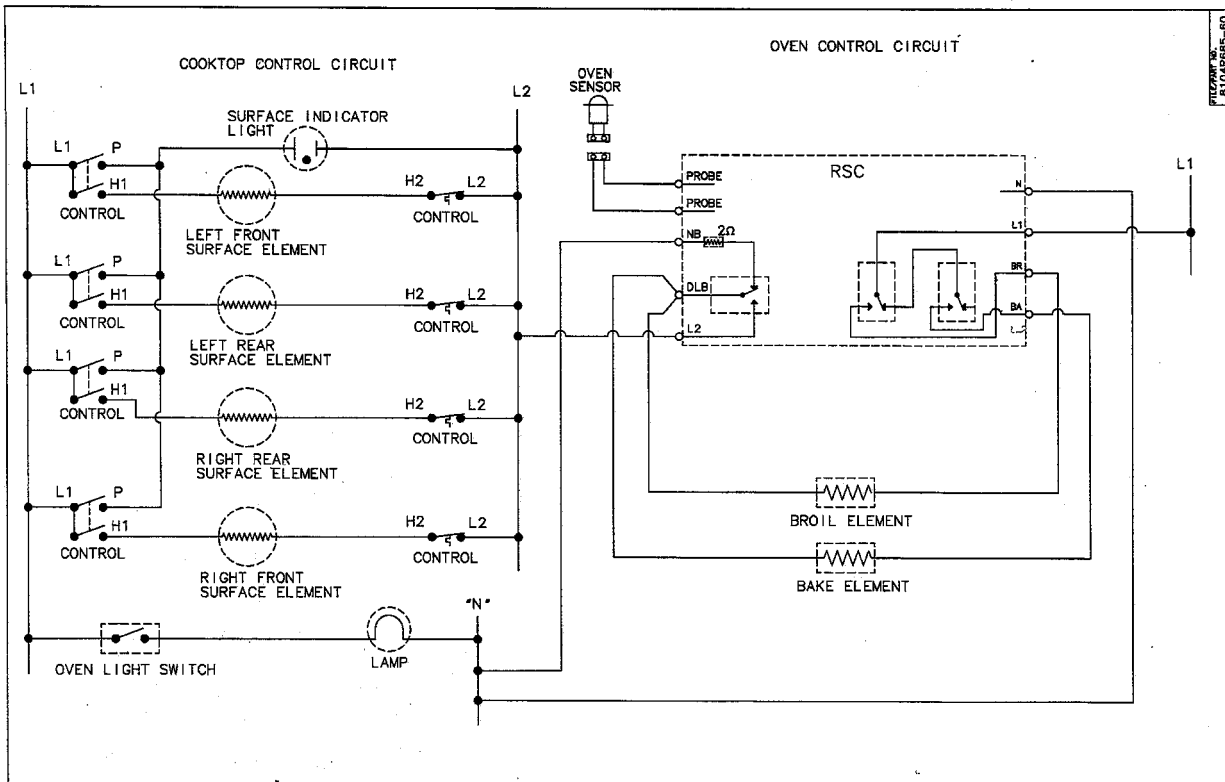
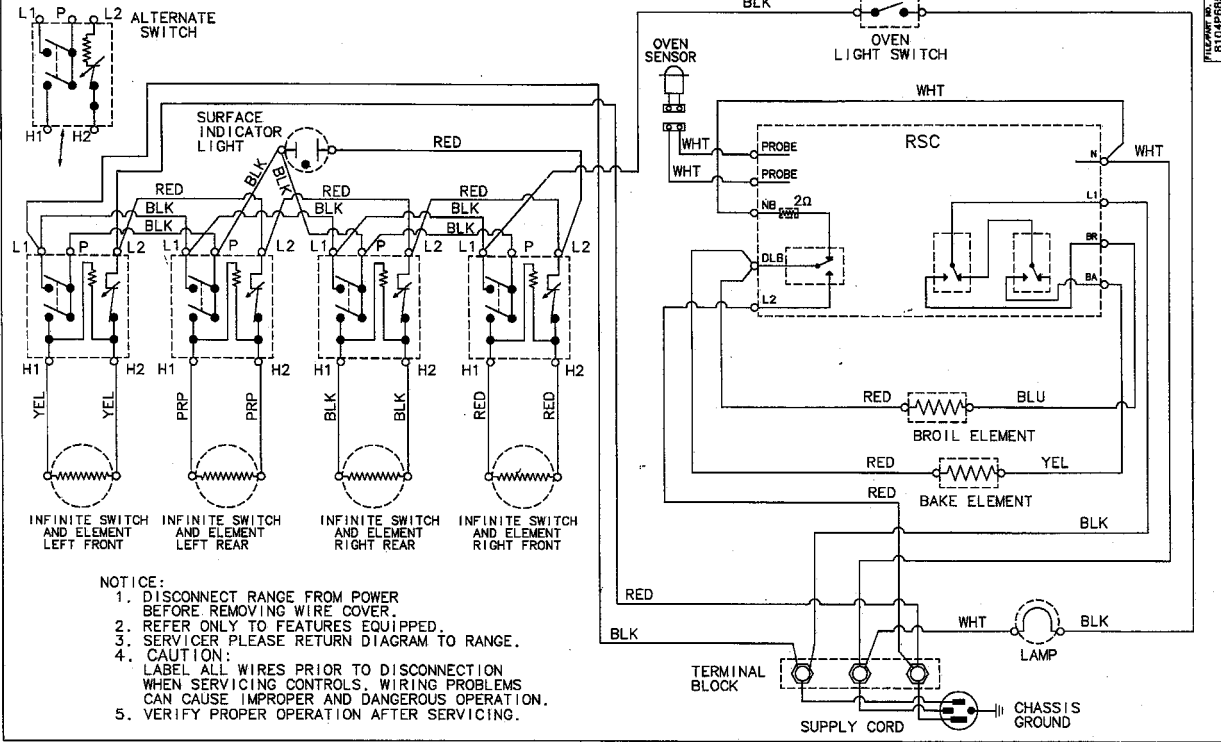

MER5730ACW MER5755AAQ MER5755AAW

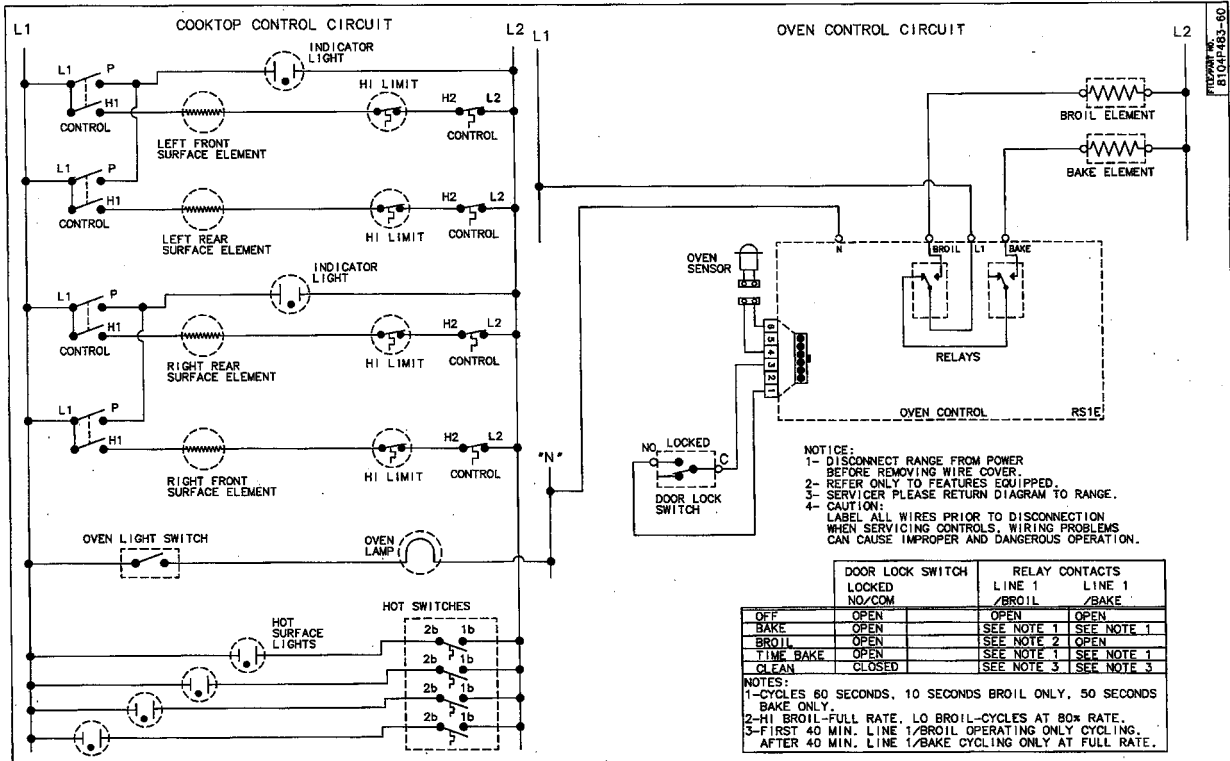
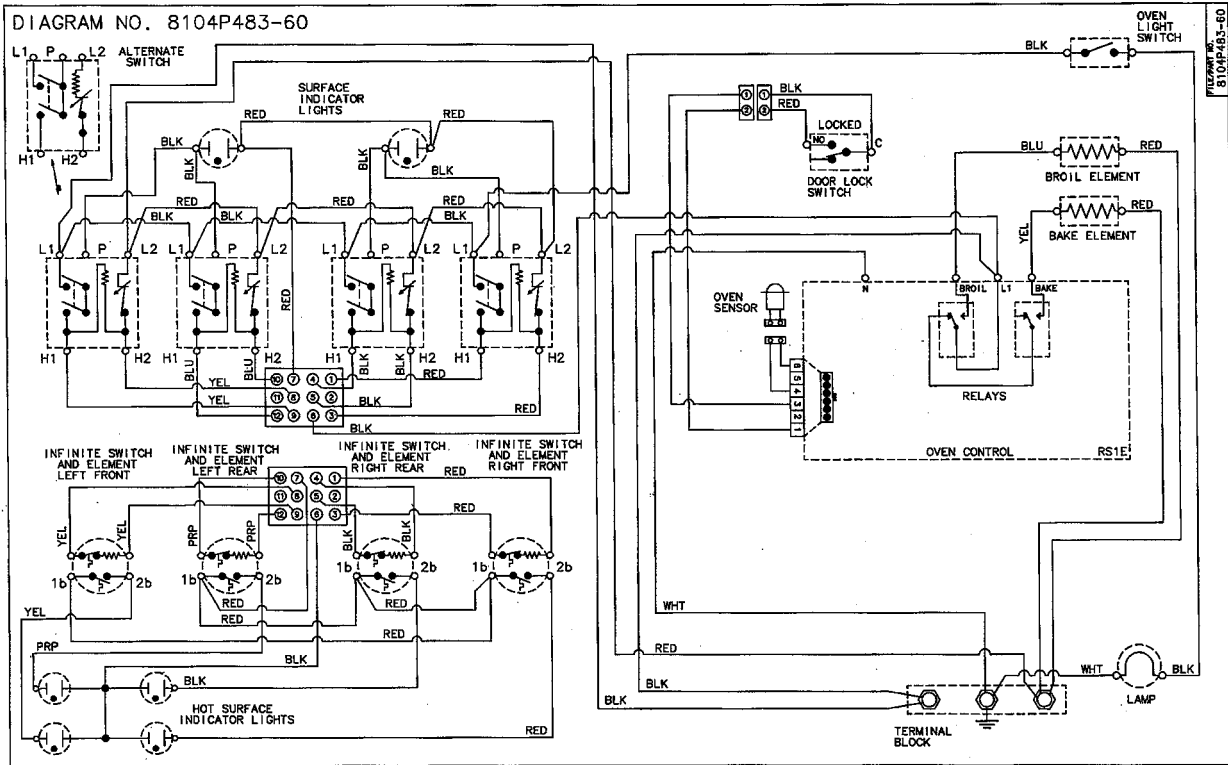

MER5770AAB MER5770AAQ MER5770AAW

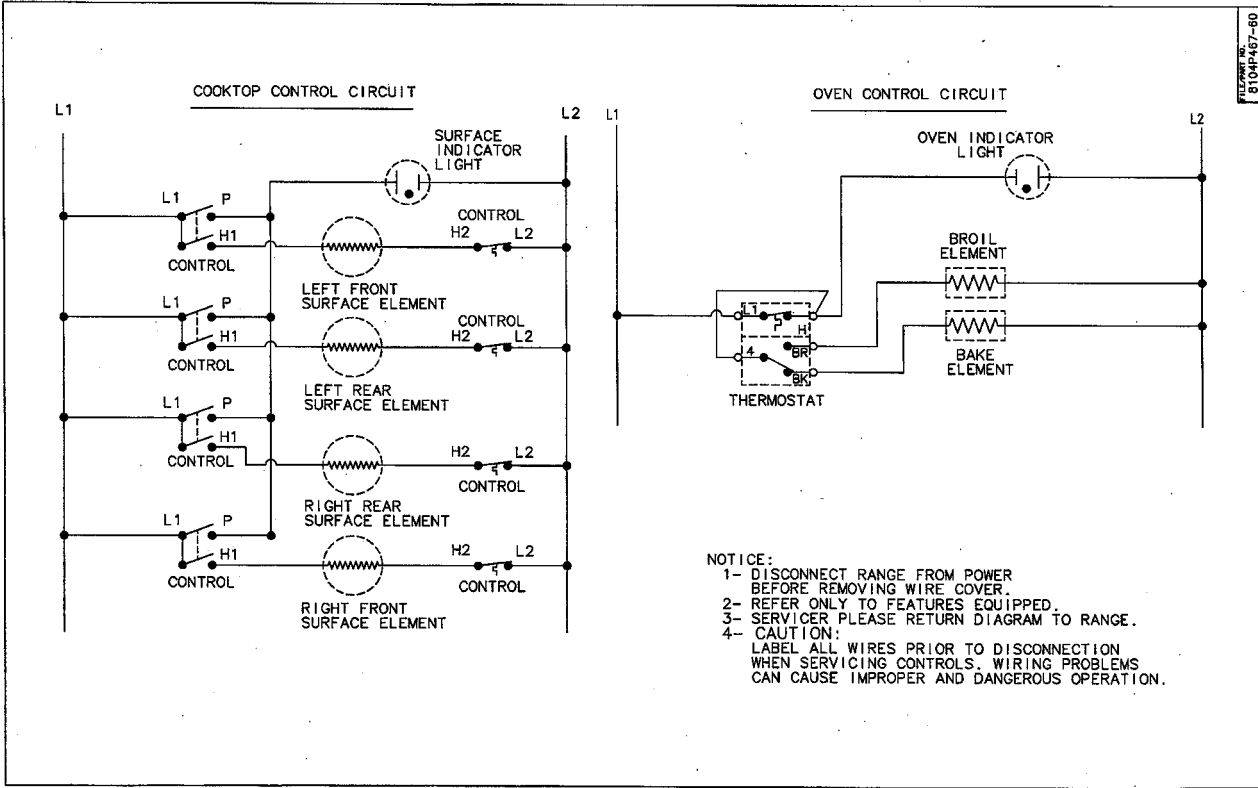
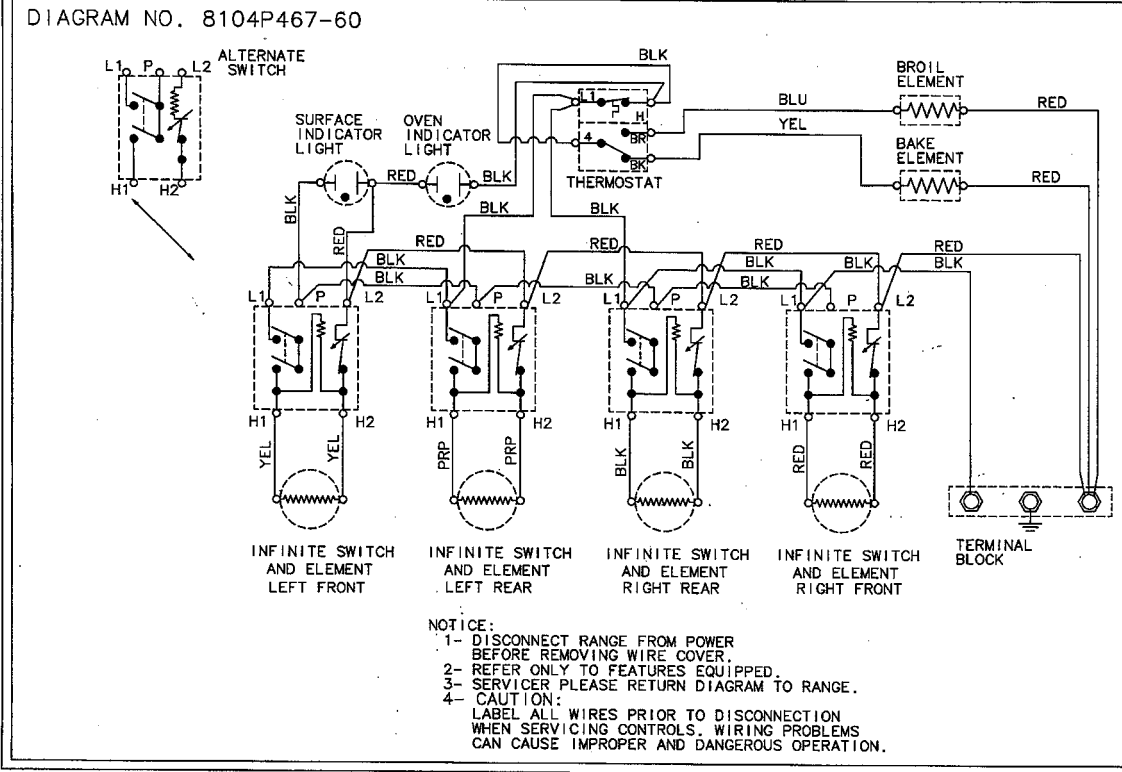

MER5770ACB MER5770ACW

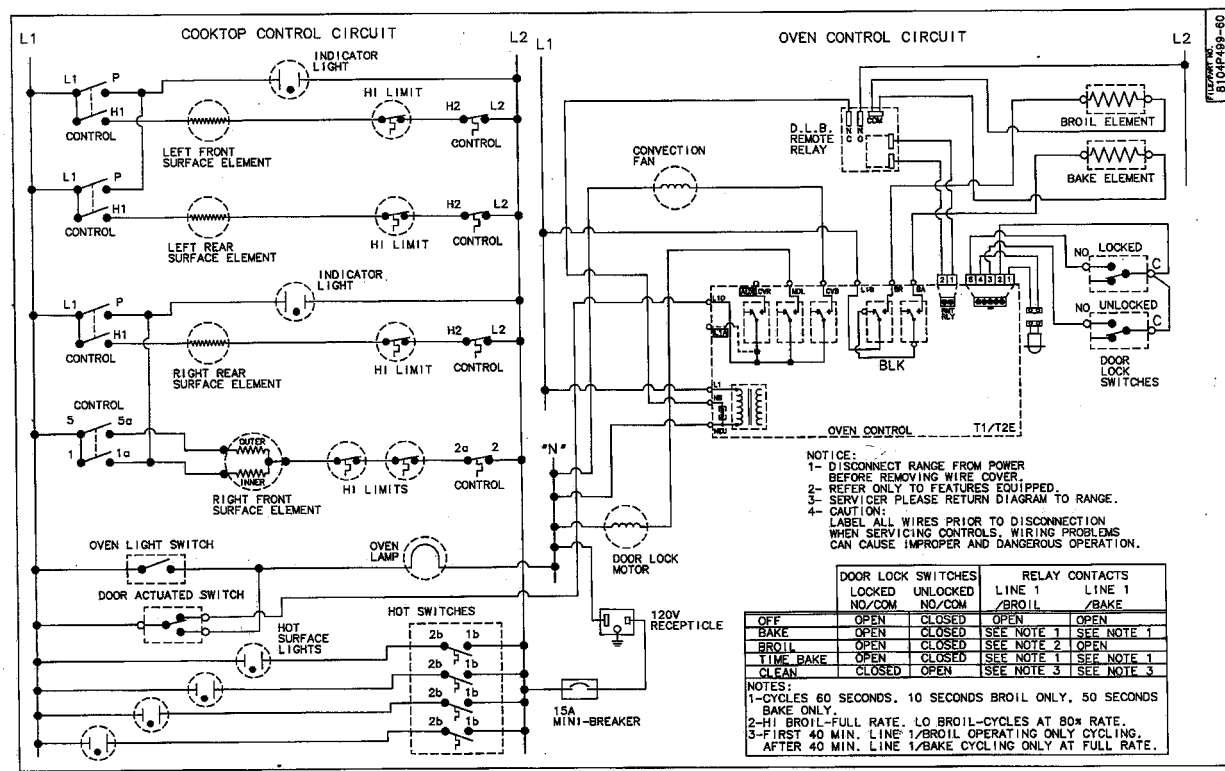
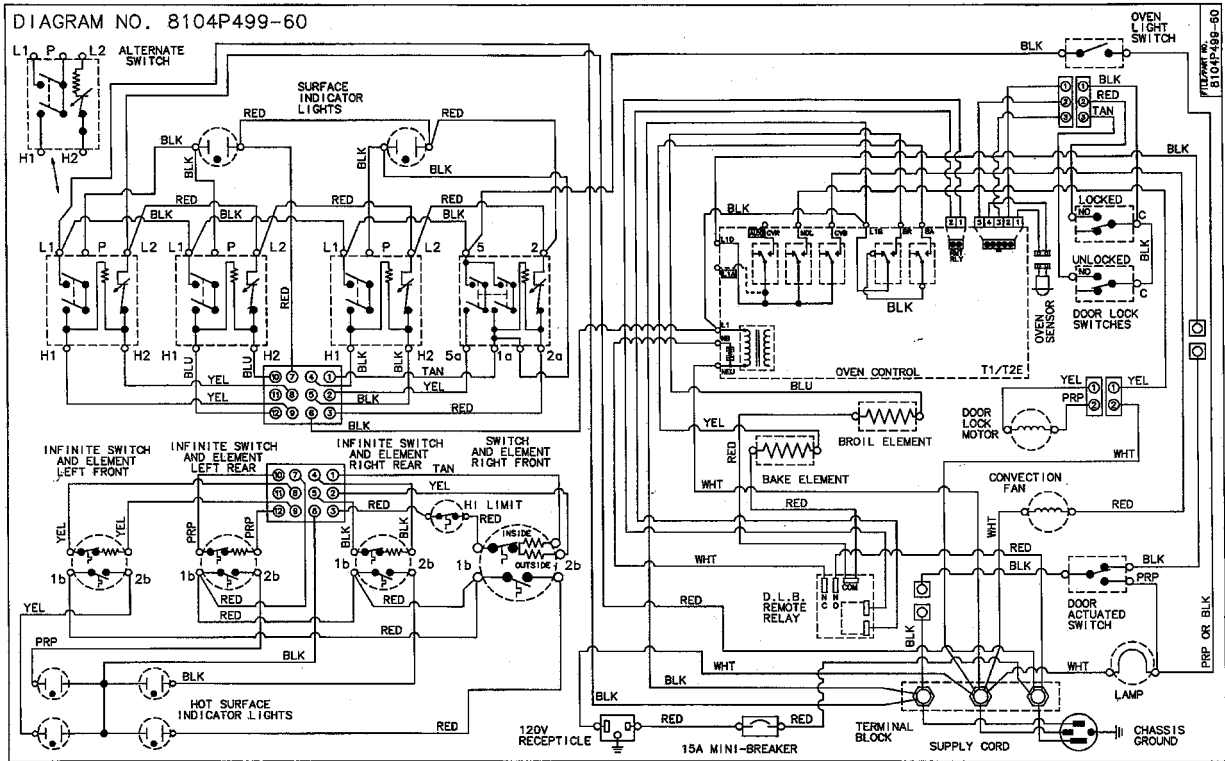

MER5775AAB MER5775AAQ MER5775AAW

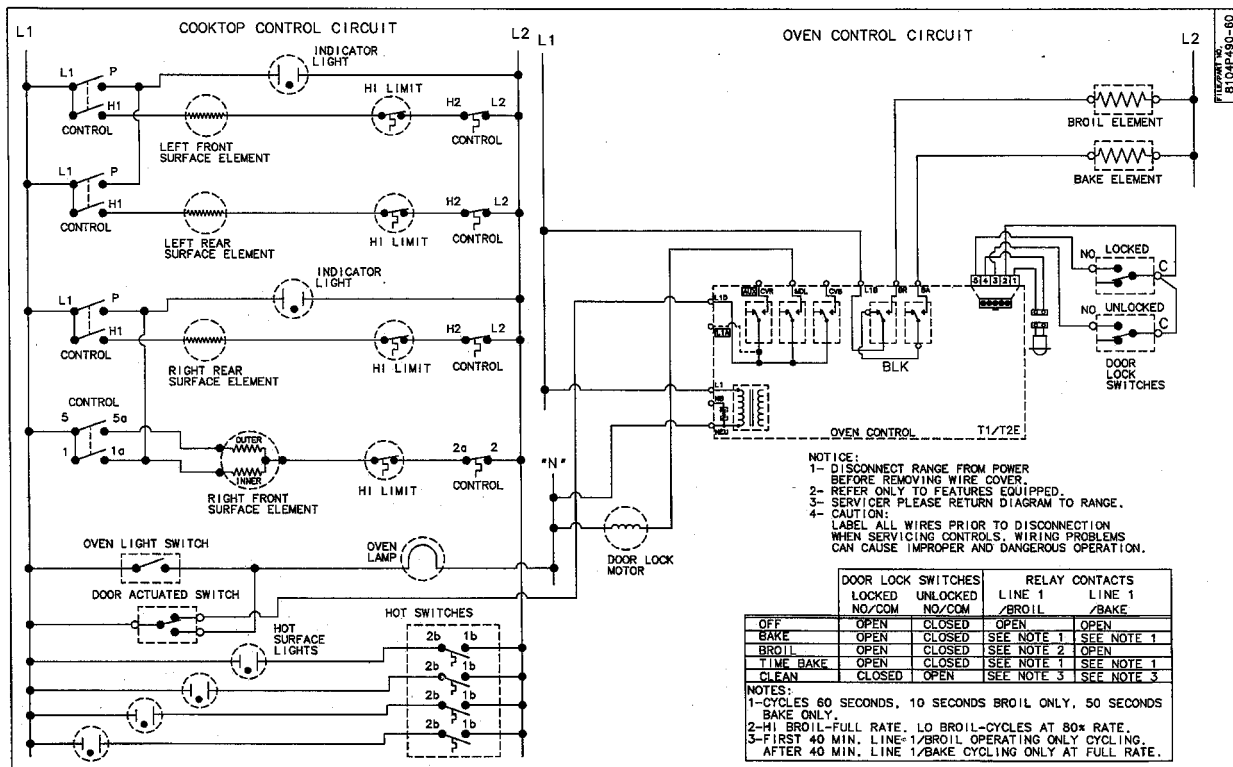
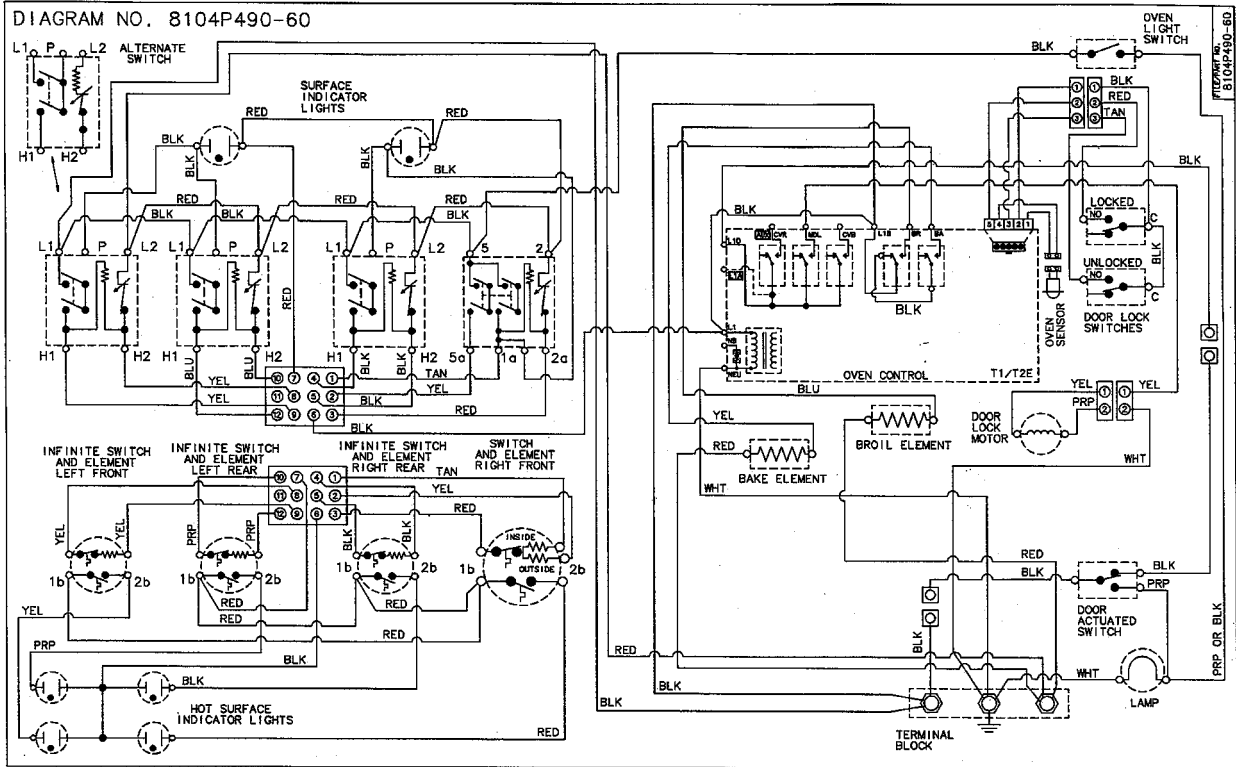

MER5870AAB MER5870AAQ MER5870AAW

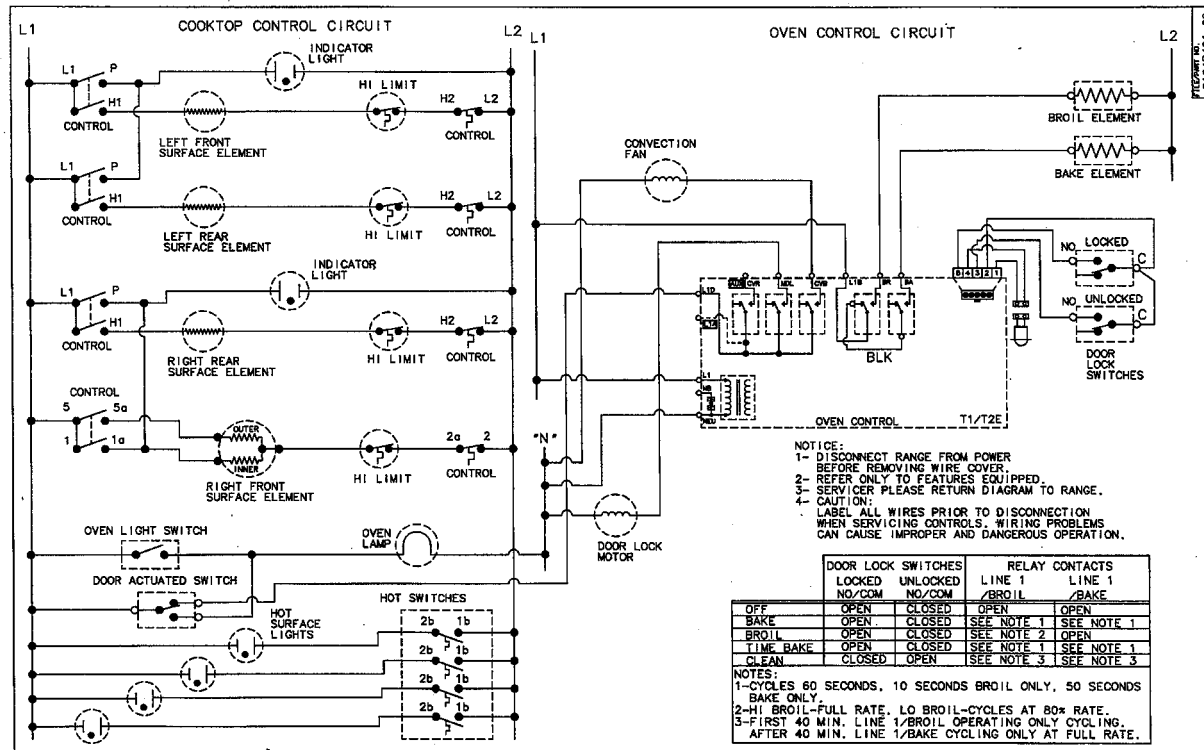
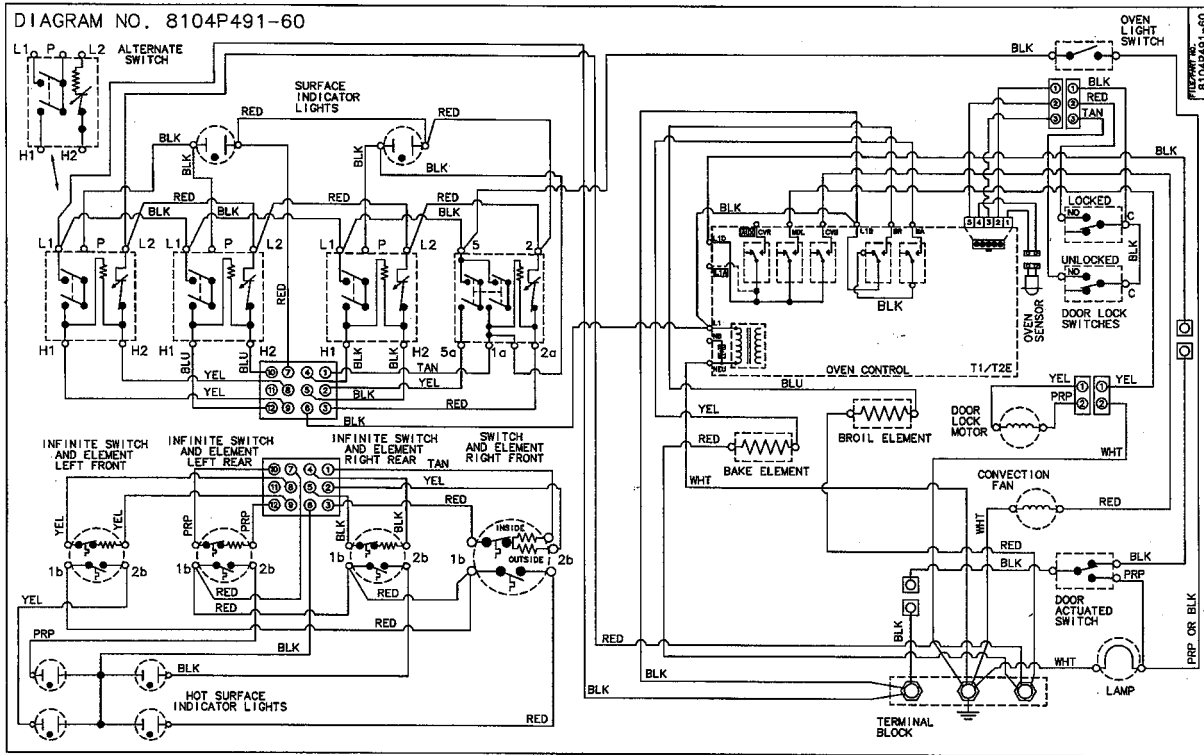

MER5870ACB MER5870ACW

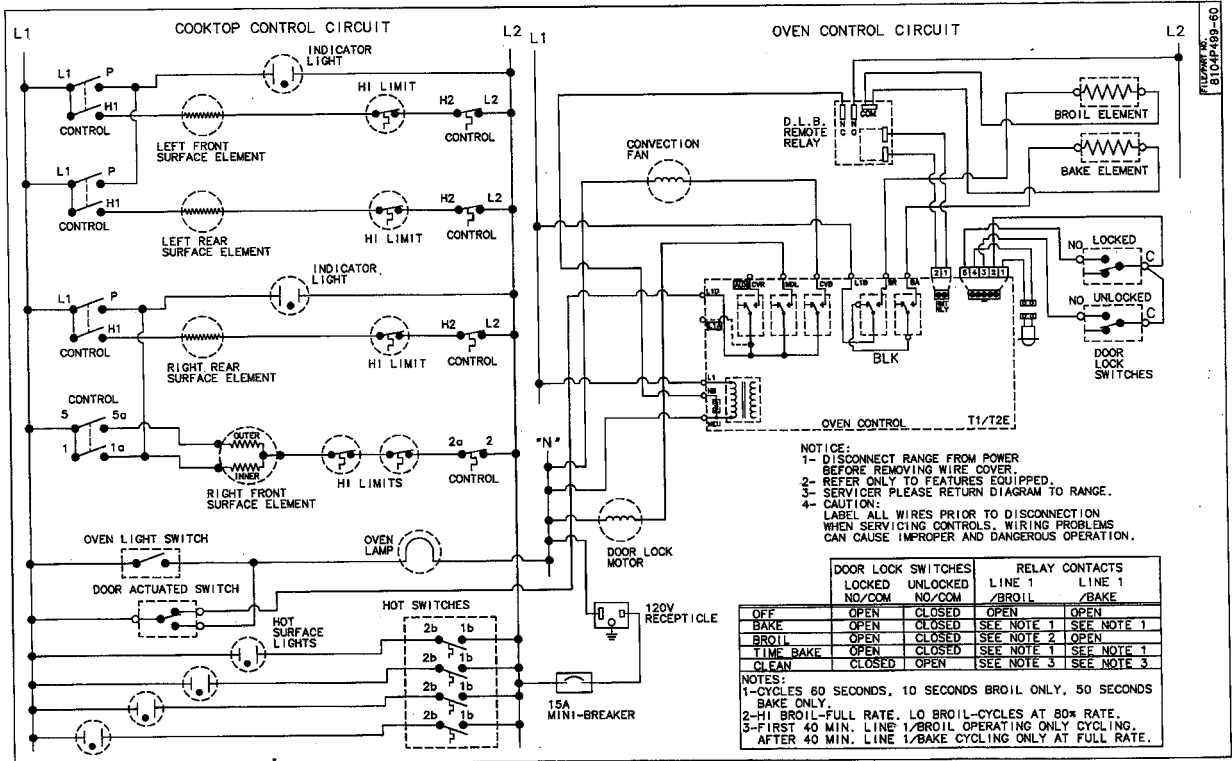
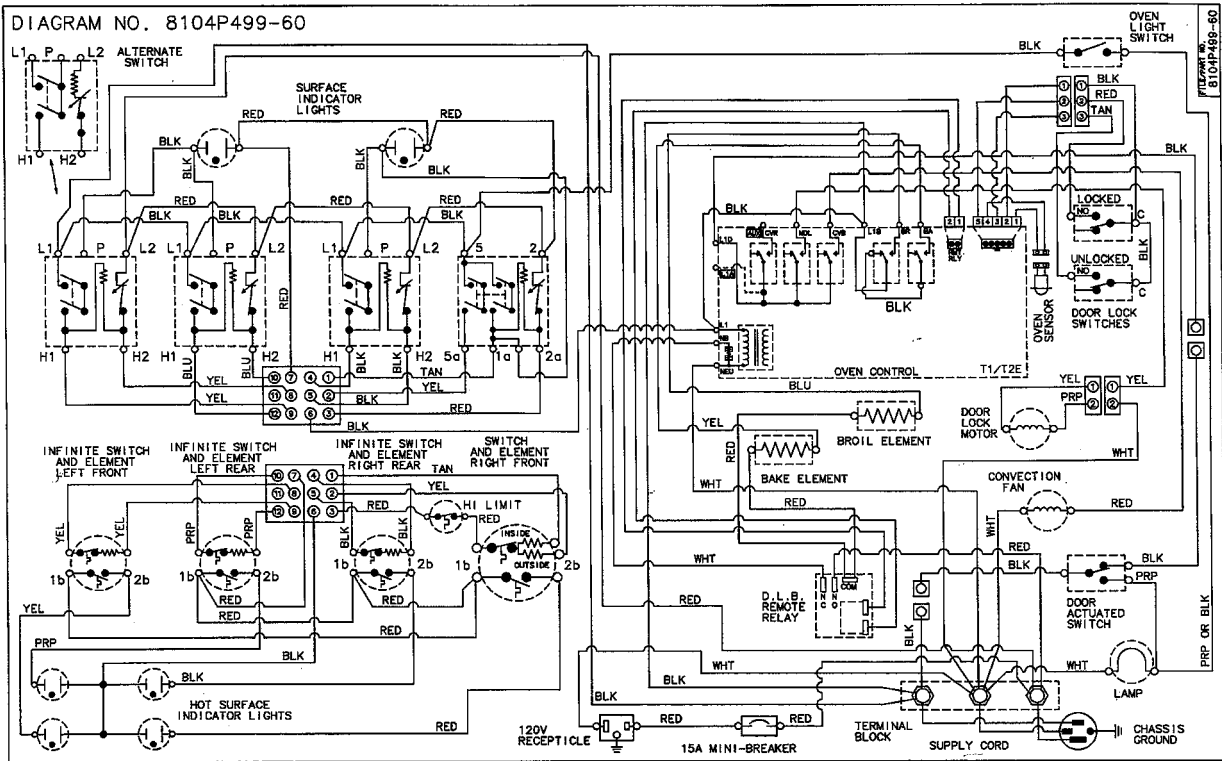

MES5570AAB

DIAGRAM NO. 8104P620-60

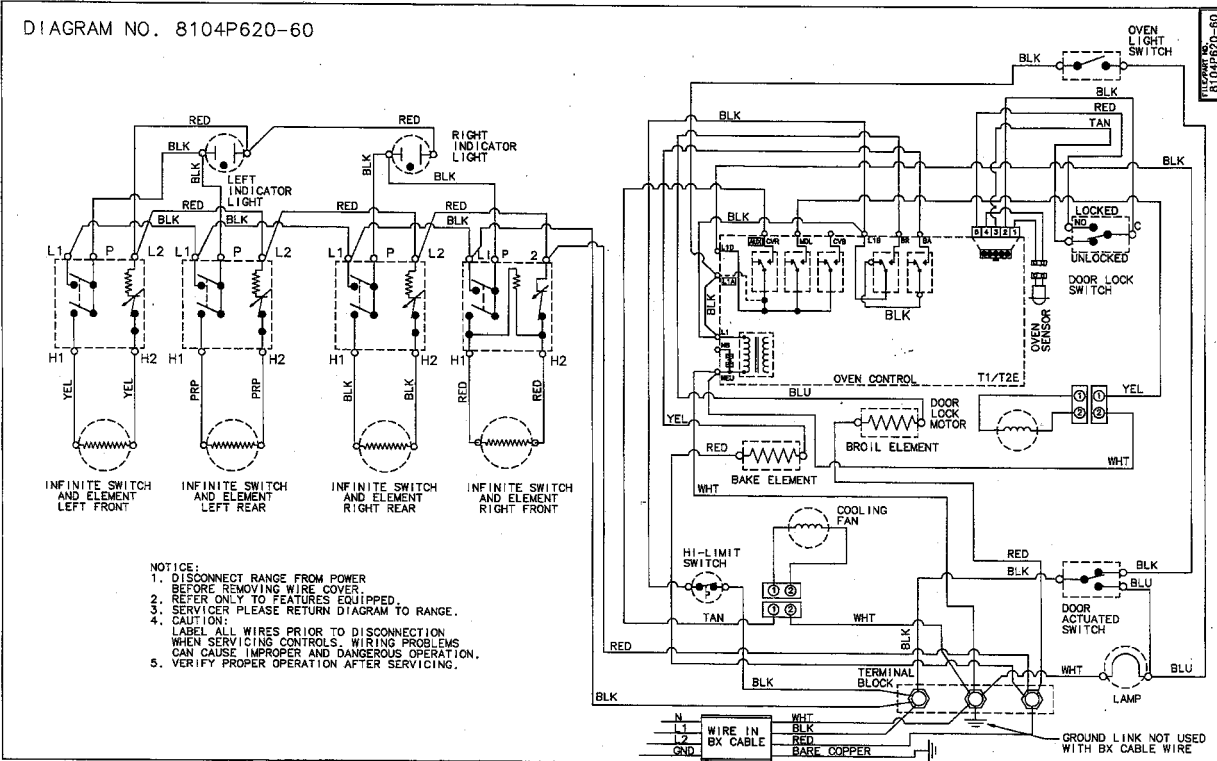

NOTICE:
 1. DISCONNECT RANGE FROM POWER BEFORE REMOVING WIRE COVER.
 2. REFER ONLY TO FEATURES EQUIPPED.
 3. SERVICER PLEASE RETURN DIAGRAM TO RANGE.
 4. CAUTION:
 LABEL ALL WIRES PRIOR TO DISCONNECTION WHEN SERVICING CONTROLS. WIRING PROBLEMS CAN CAUSE IMPROPER AND DANGEROUS OPERATION.
 5. VERIFY PROPER OPERATION AFTER SERVICING.

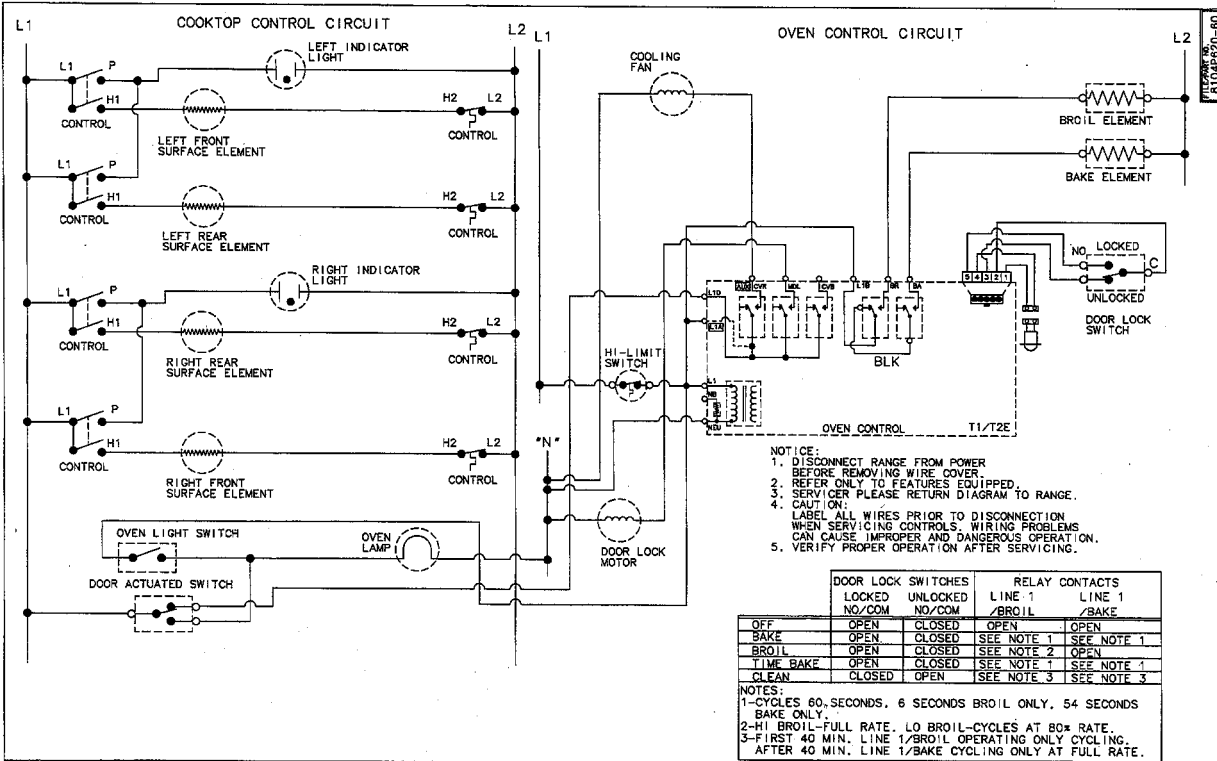

NOTICE:
 1. DISCONNECT RANGE FROM POWER BEFORE REMOVING WIRE COVER.
 2. REFER ONLY TO FEATURES EQUIPPED.
 3. SERVICER PLEASE RETURN DIAGRAM TO RANGE.
 4. CAUTION:
 LABEL ALL WIRES PRIOR TO DISCONNECTION WHEN SERVICING CONTROLS. WIRING PROBLEMS CAN CAUSE IMPROPER AND DANGEROUS OPERATION.
 5. VERIFY PROPER OPERATION AFTER SERVICING.

	DOOR LOCK SWITCHES		RELAY CONTACTS	
	LOCKED NO/COM	UNLOCKED NO/COM	LINE 1 /BROIL	LINE 1 /BAKE
OFF	OPEN	CLOSED	OPEN	OPEN
BAKE	OPEN	CLOSED	SEE NOTE 1	SEE NOTE 1
BROIL	OPEN	CLOSED	SEE NOTE 2	OPEN
TIME BAKE	OPEN	CLOSED	SEE NOTE 1	SEE NOTE 1
CLEAN	CLOSED	OPEN	SEE NOTE 3	SEE NOTE 3

NOTES:
 1-CYCLES 60, SECONDS, 6 SECONDS BROIL ONLY, 54 SECONDS BAKE ONLY.
 2-HI BROIL-FULL RATE, LO BROIL-CYCLES AT 80% RATE.
 3-FIRST 40 MIN. LINE 1/BROIL OPERATING ONLY CYCLING. AFTER 40 MIN. LINE 1/BAKE CYCLING ONLY AT FULL RATE.

MES5770AAB MES5770AAQ MES5770AAW MES5870AAB MES5870AAQ
MES5870AAW

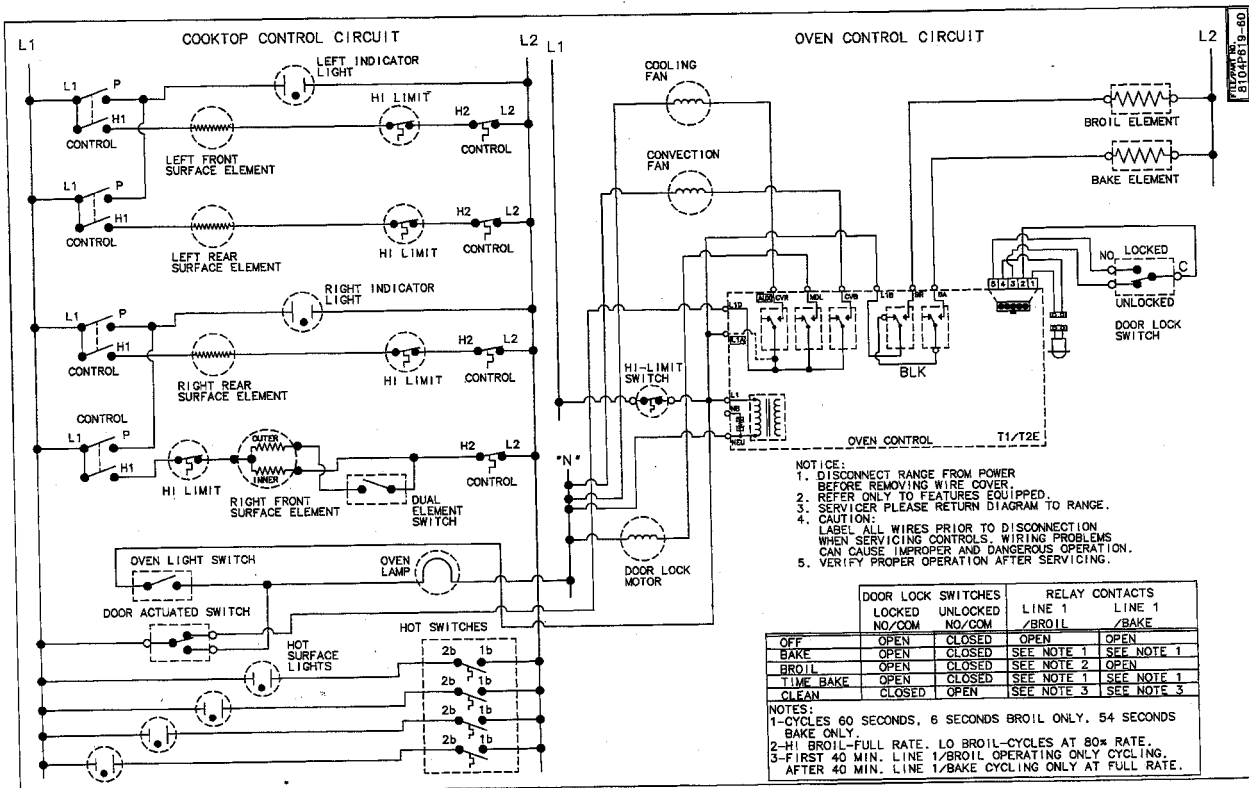
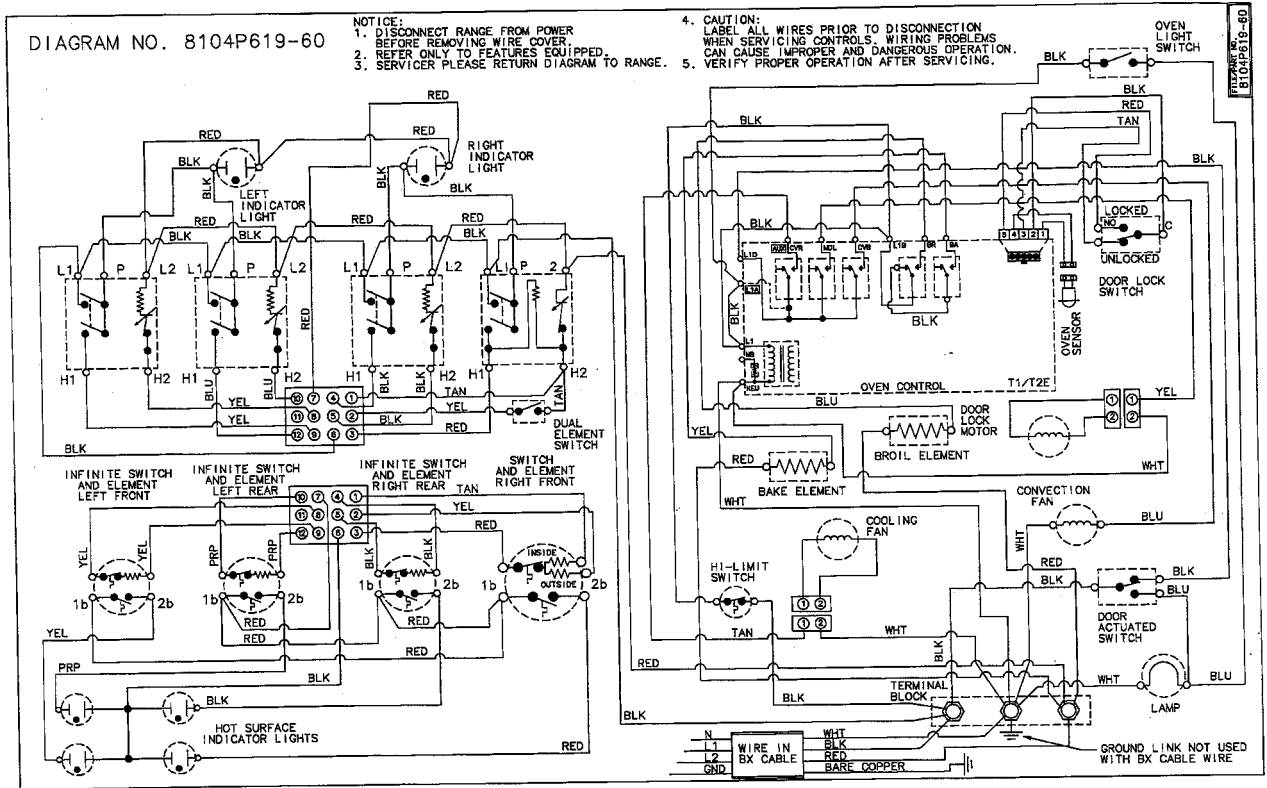

MGS5770ADB MGS5770ADQ MGS5770ADW MGS5870ADB MGS5870ADQ MGS5870ADW

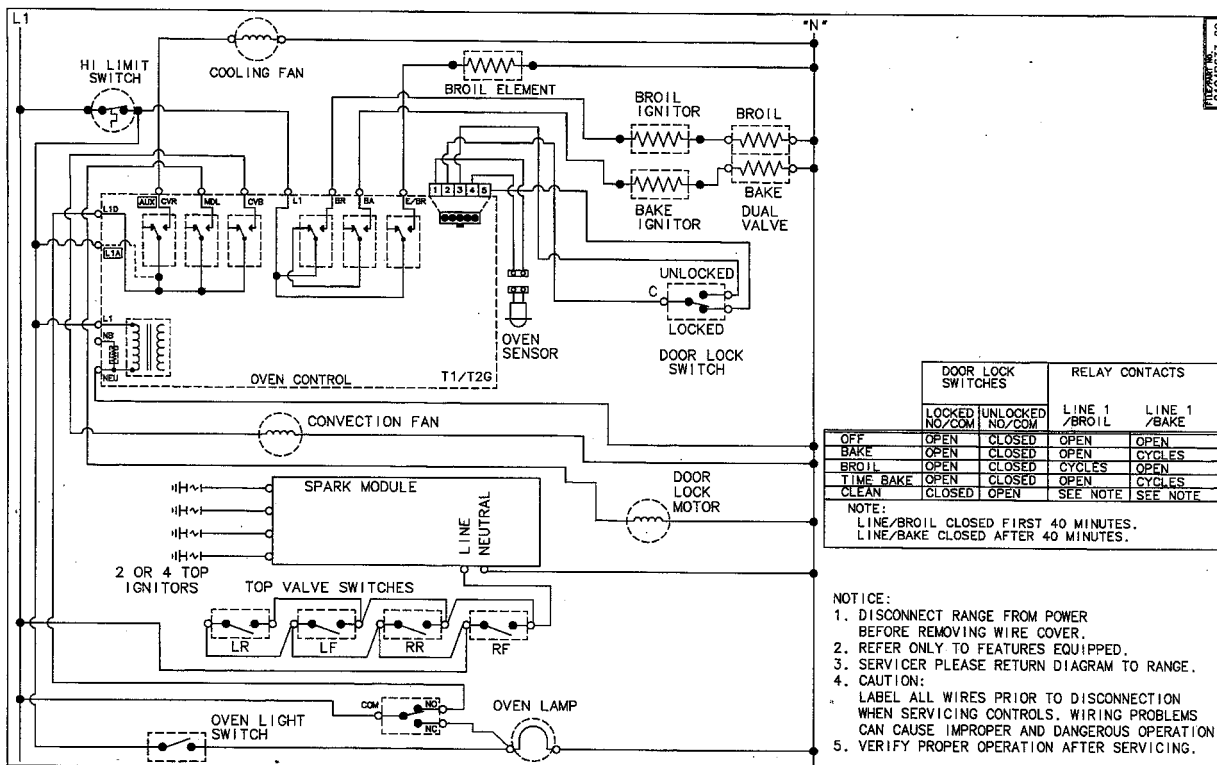
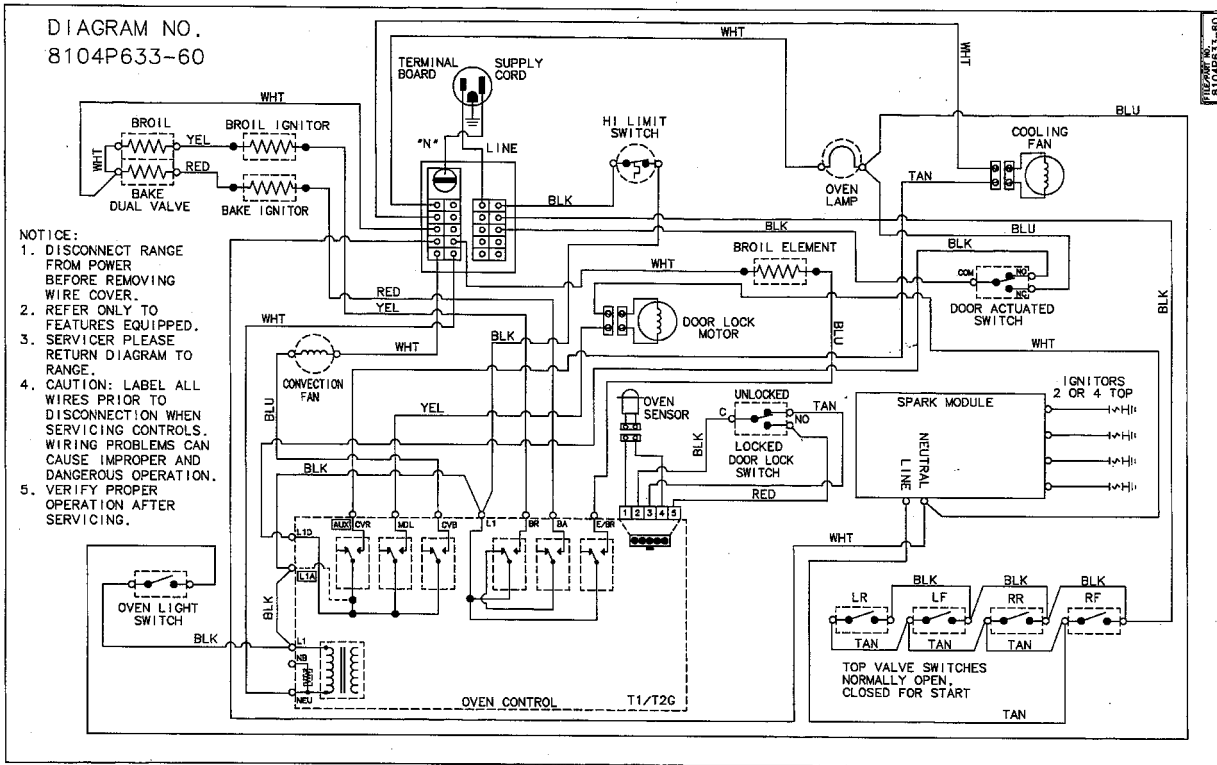

PER4510AAQ PER4510AAW

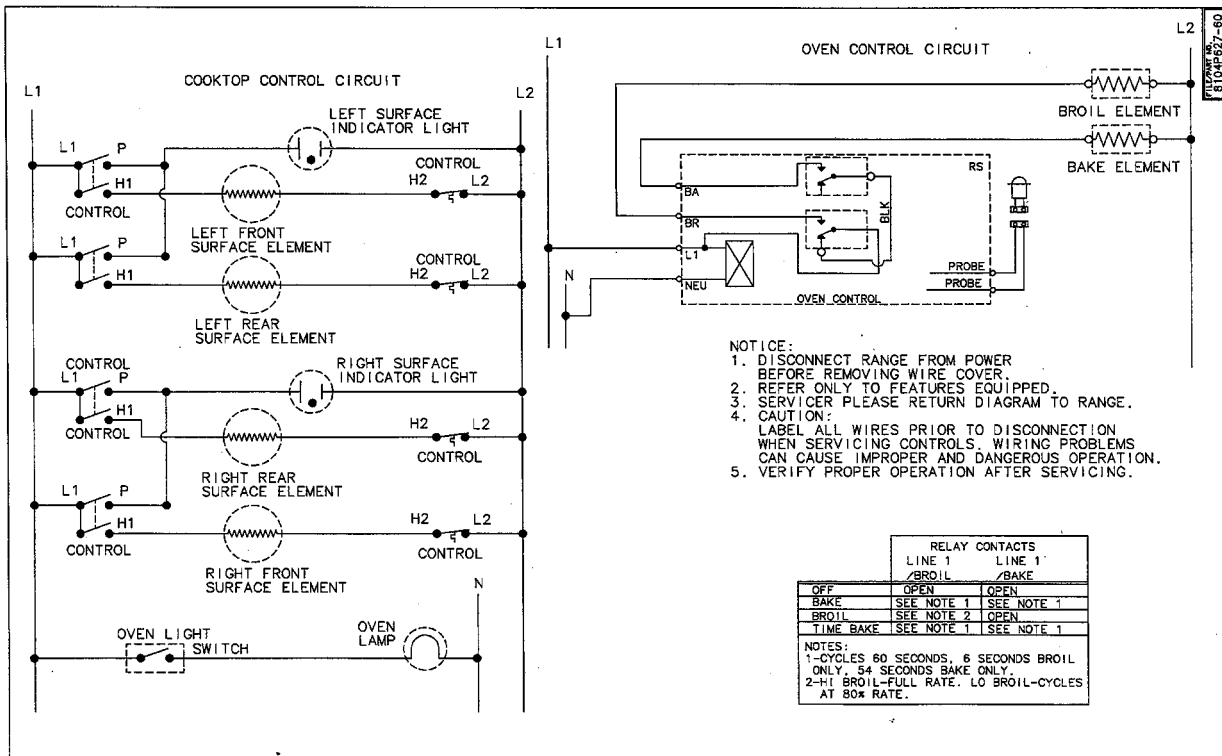
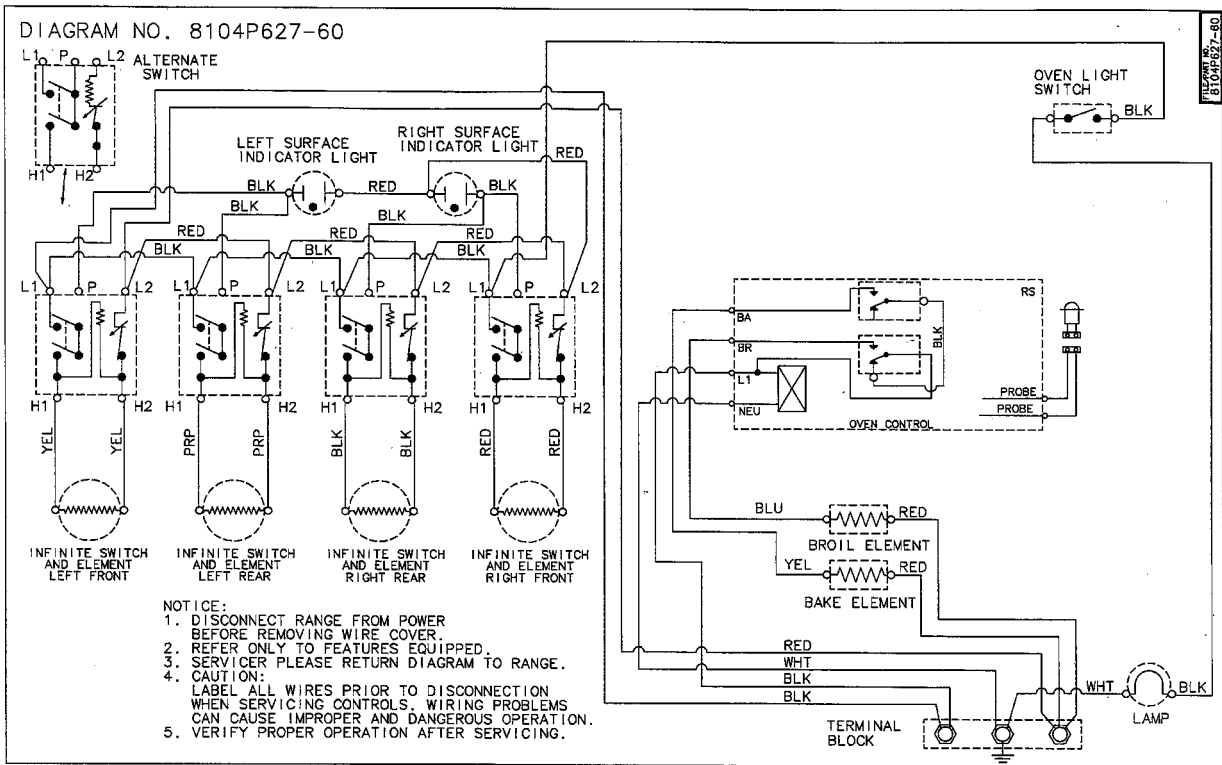

PER5510AAQ PER5510AAW

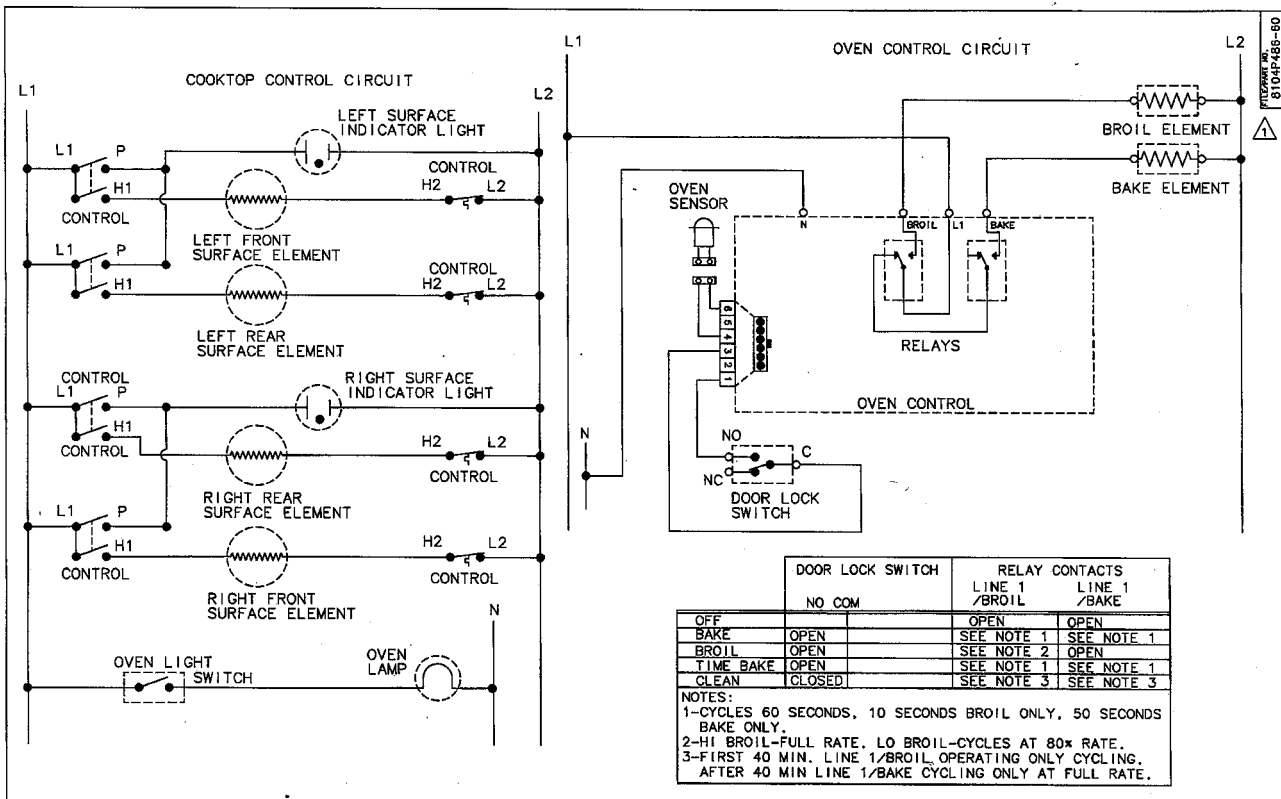
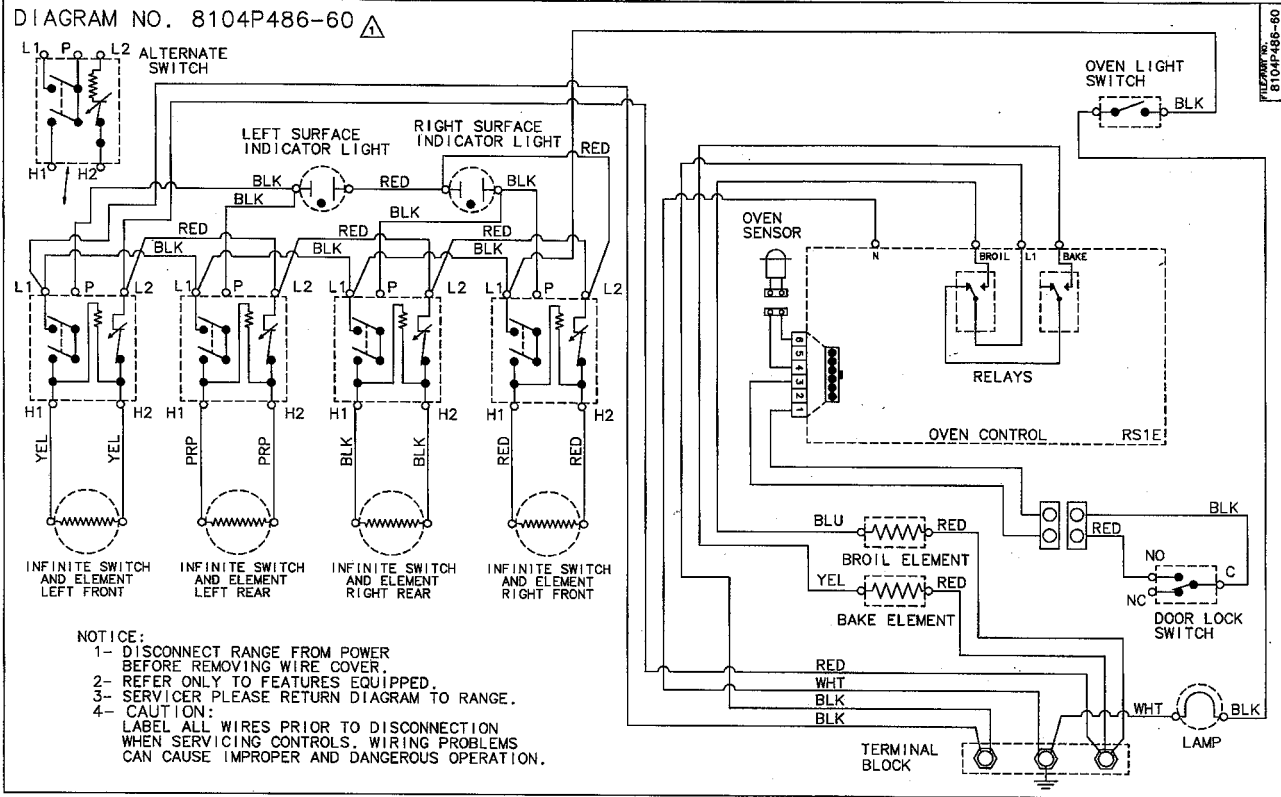

International Admiral Models: ABR3740AGW

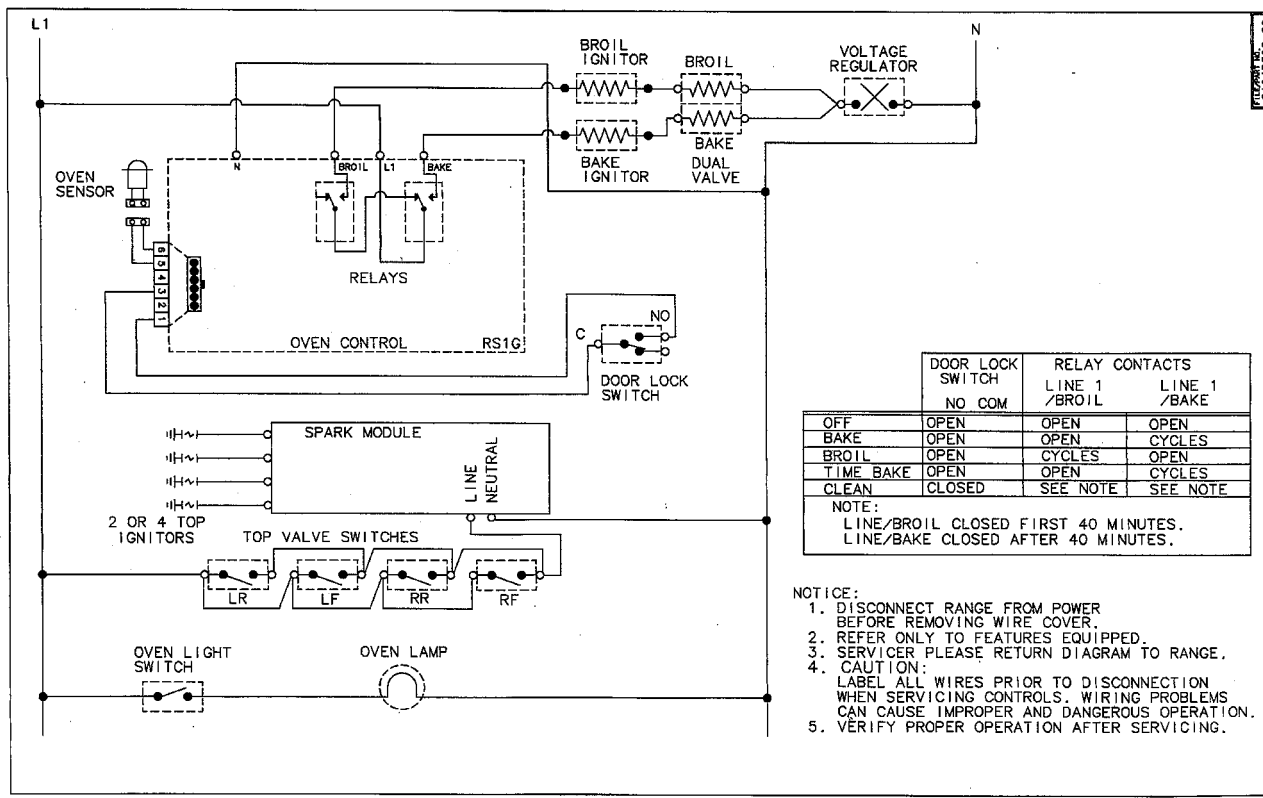
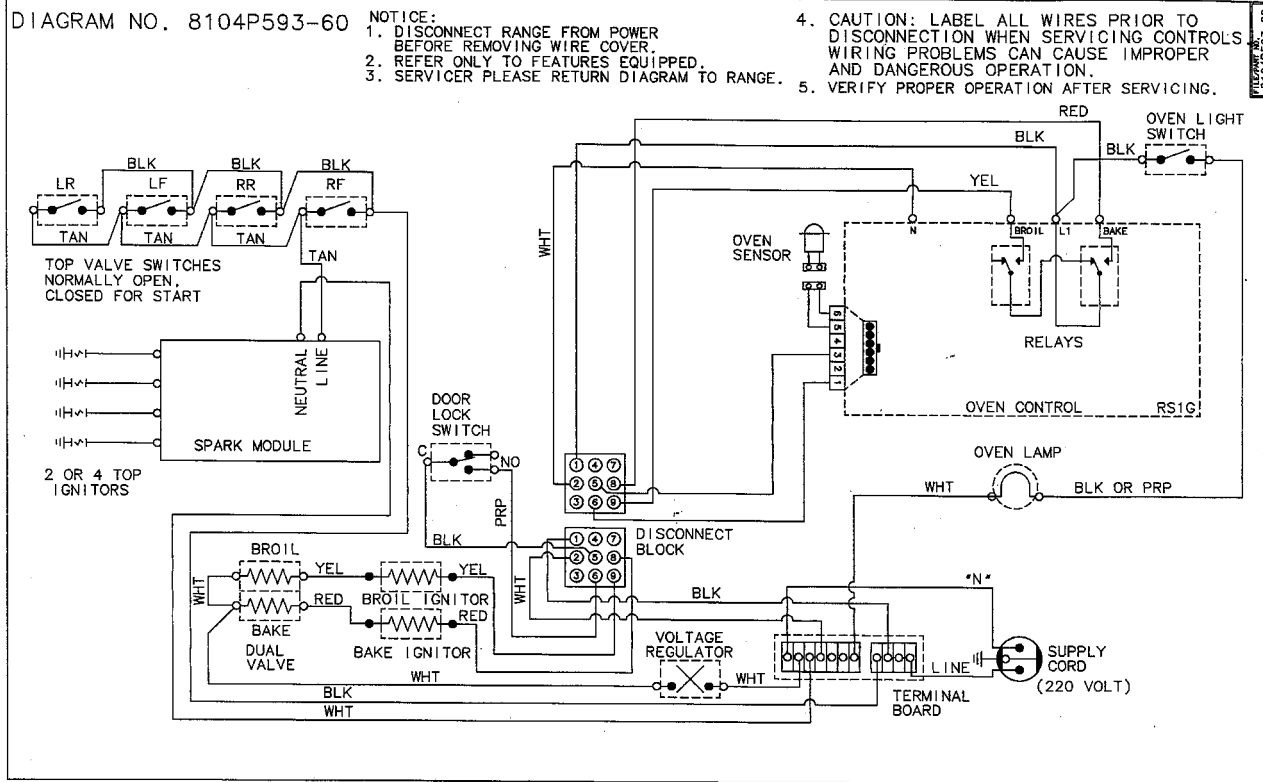

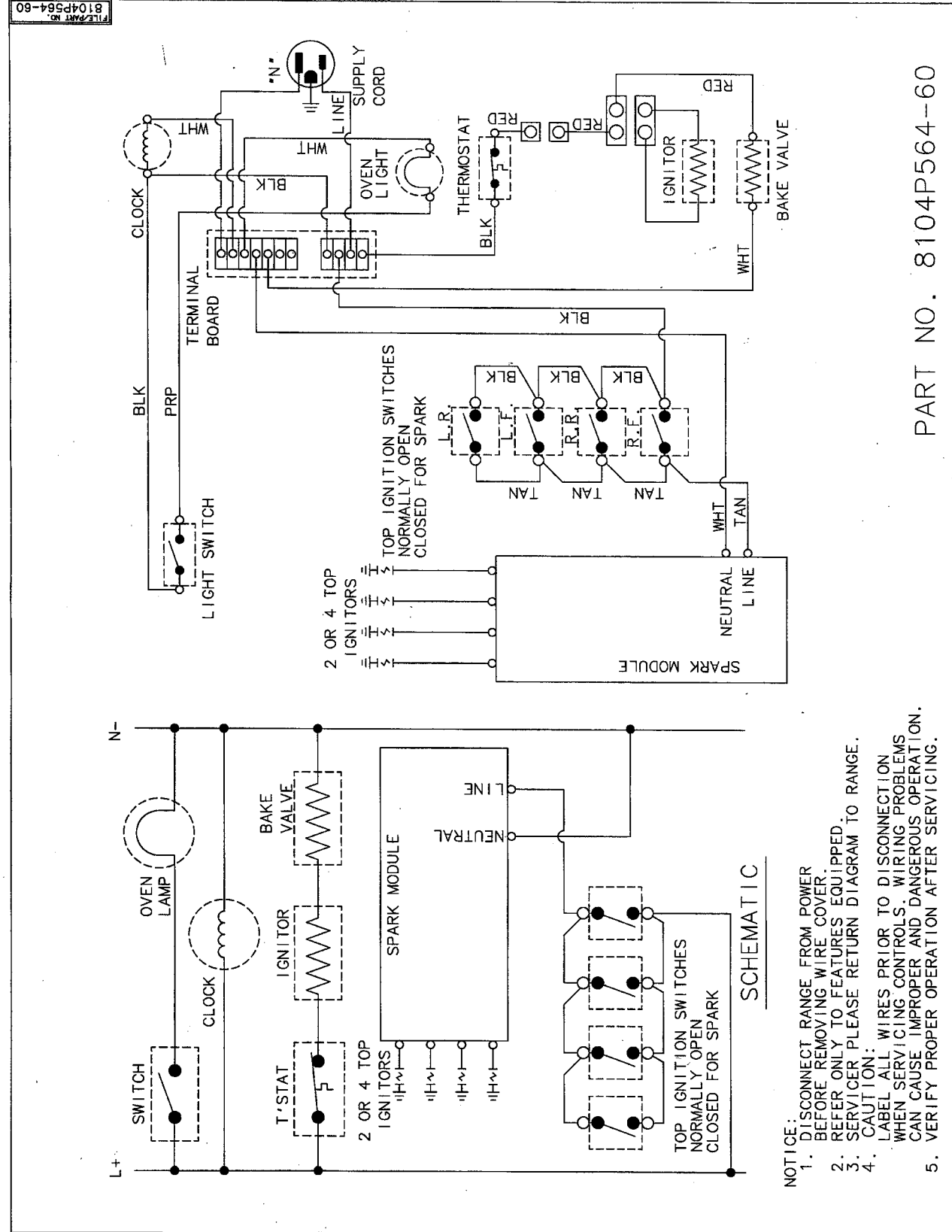

PART NO. 8104P564--60



IMPORTANT

Wiring information in this manual was accurate at the time of manual production. Wiring information is subject to change at any time. Please refer to wiring information on the actual product for most current information.

*Because of the simple design of this appliance, wiring is minimal. No engineering diagrams are available. Please refer to information supplied with the unit.

FILE PART NO. 8104P564-60

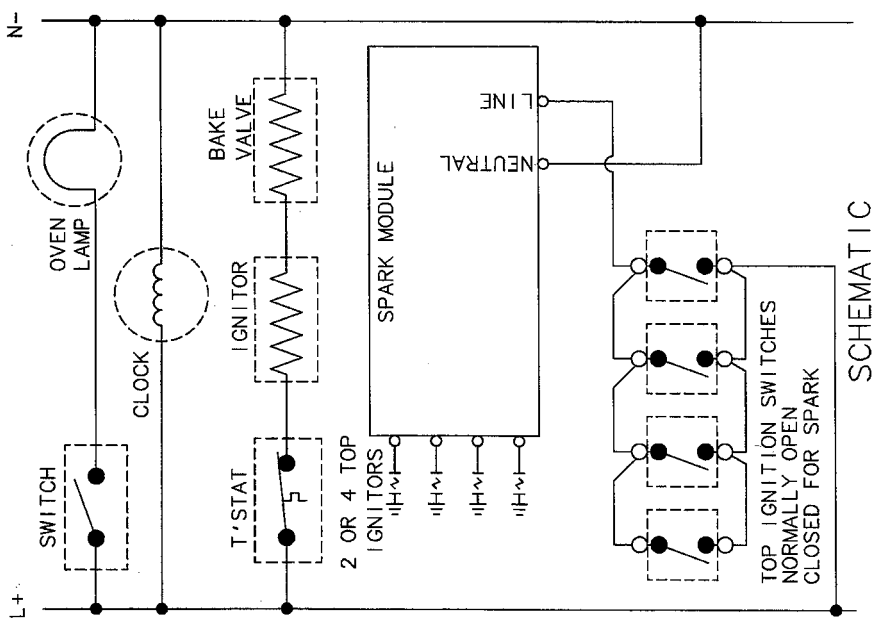
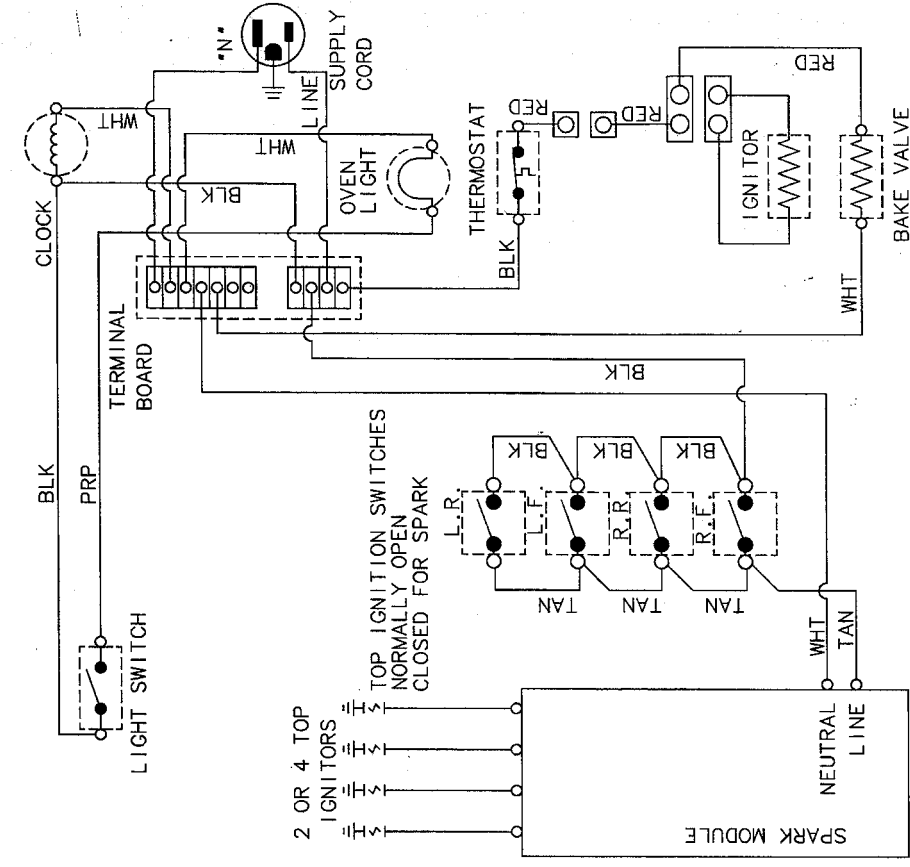

SCHEMATIC

- NOTICE:
1. DISCONNECT RANGE FROM POWER BEFORE REMOVING WIRE COVER.
 2. REFER ONLY TO FEATURES EQUIPPED.
 3. SERVICER PLEASE RETURN DIAGRAM TO RANGE.
 4. CAUTION: LABEL ALL WIRES PRIOR TO DISCONNECTION WHEN SERVICING CONTROLS. WIRING PROBLEMS CAN CAUSE IMPROPER AND DANGEROUS OPERATION.
 5. VERIFY PROPER OPERATION AFTER SERVICING.

PART NO. 8104P564-60

AER1110AAH

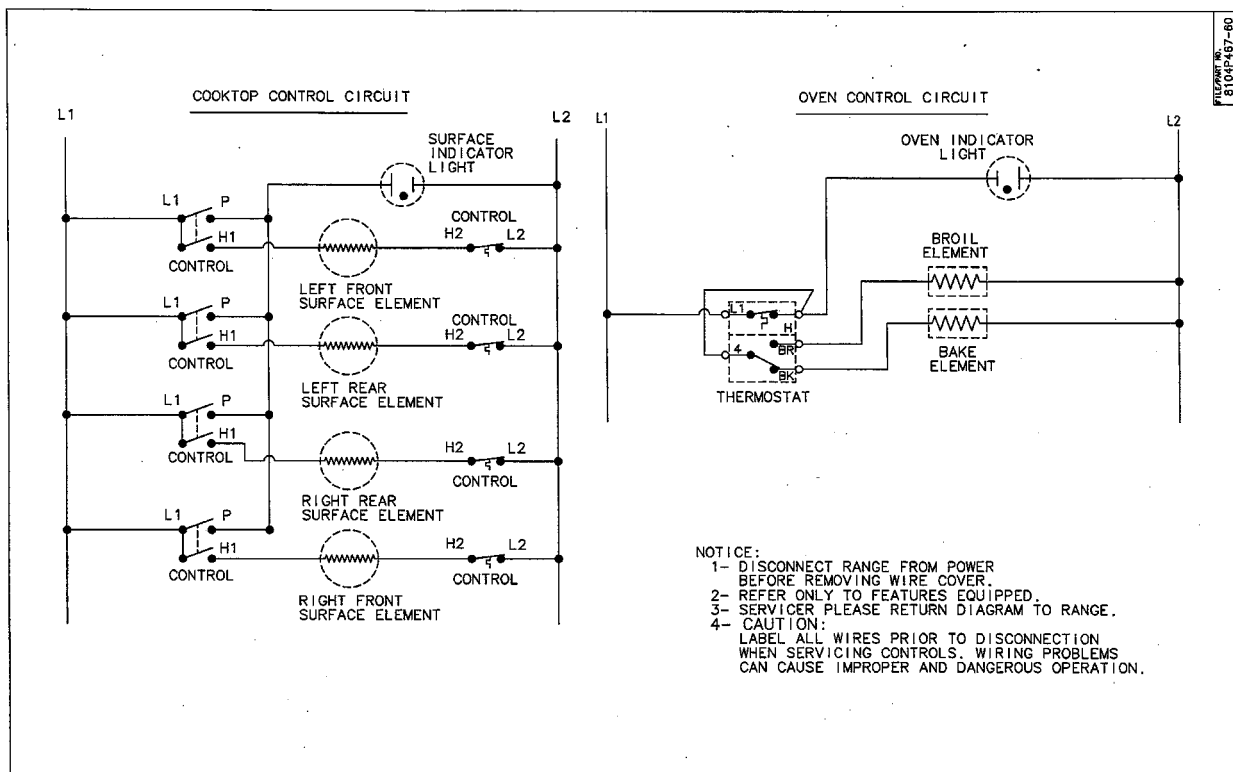
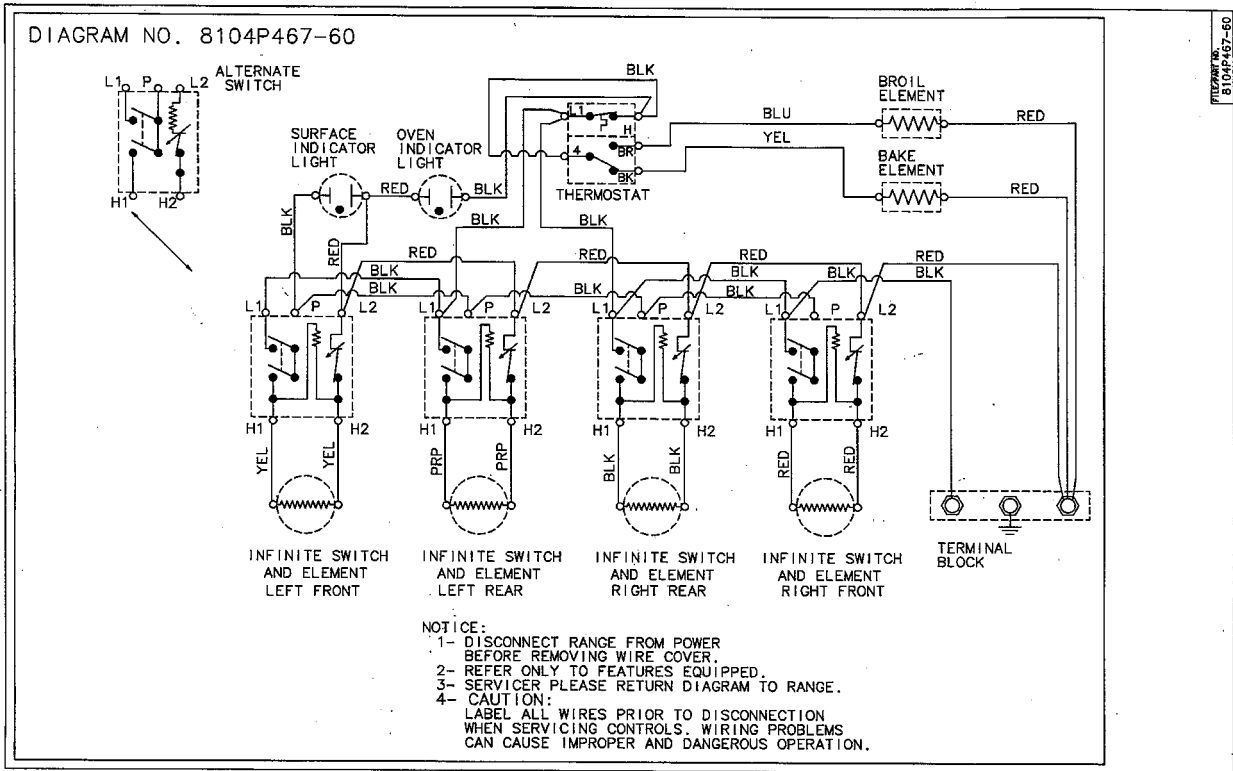

AER1140AGH

DIAGRAM NO. 8104P539-60

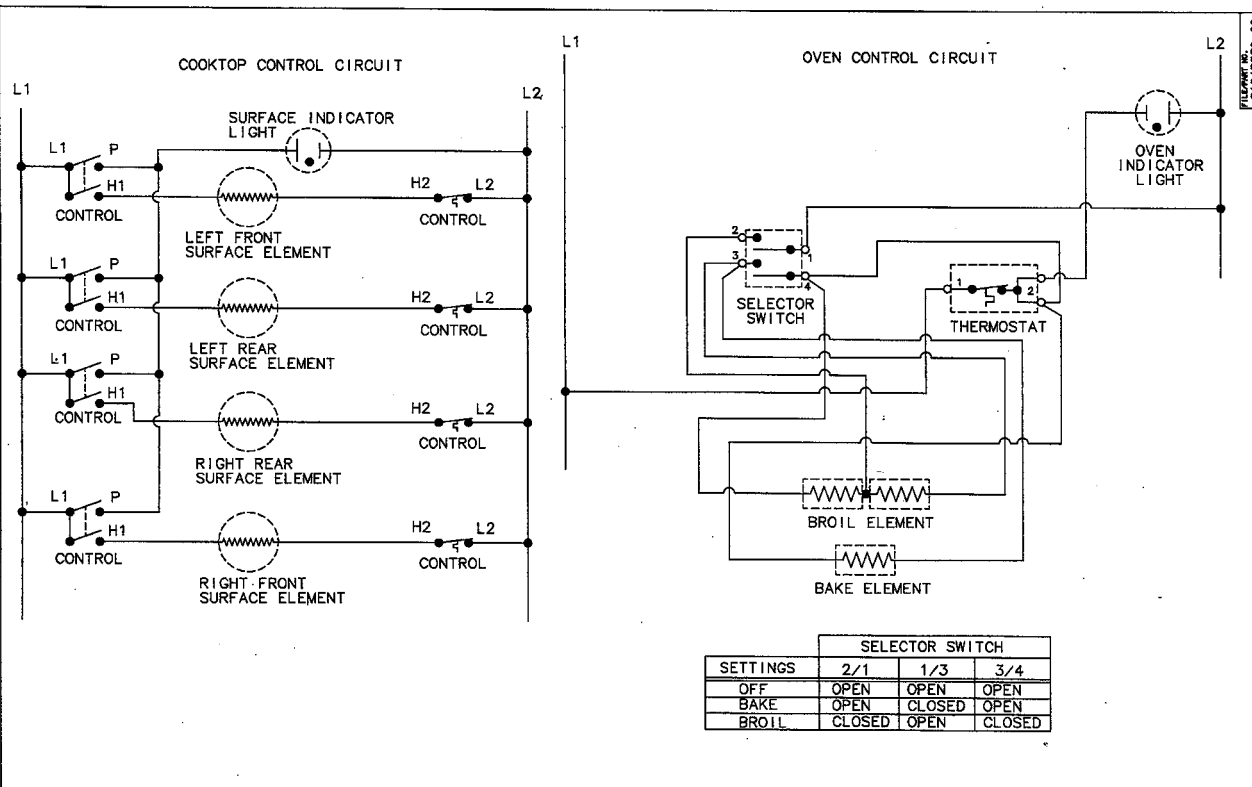
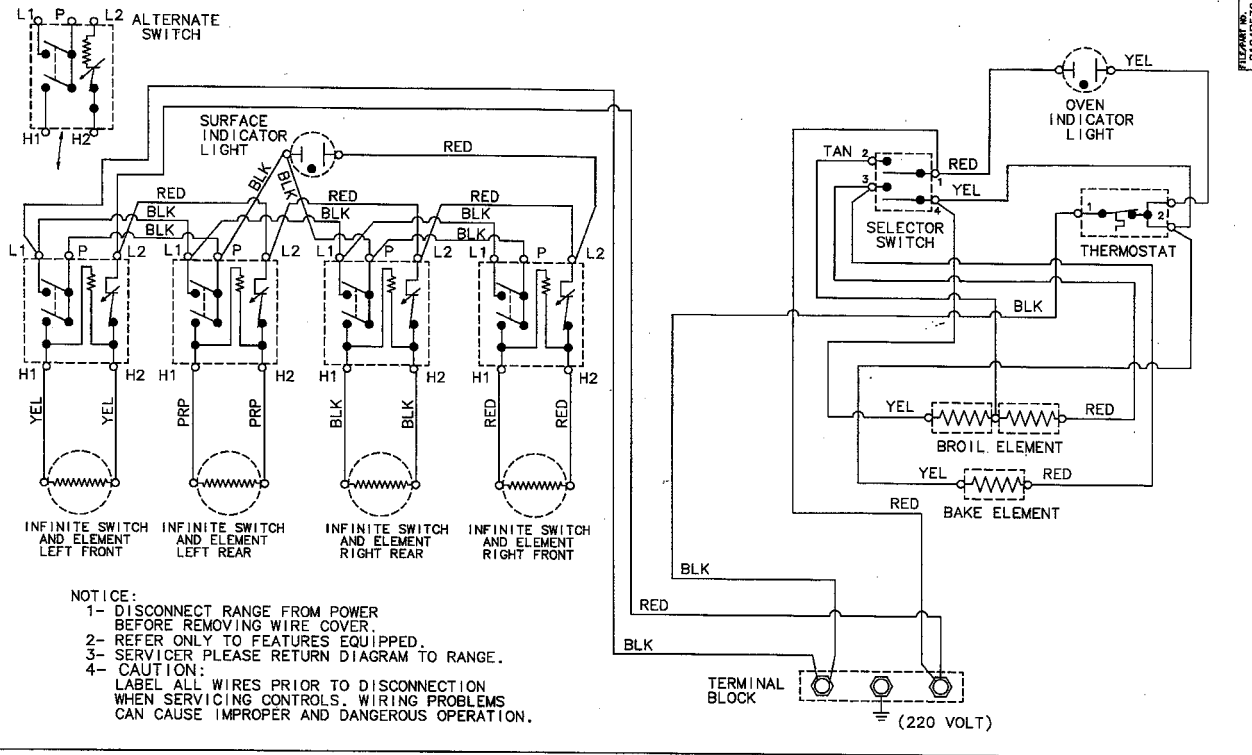

AER1350AAH AER1350AAT

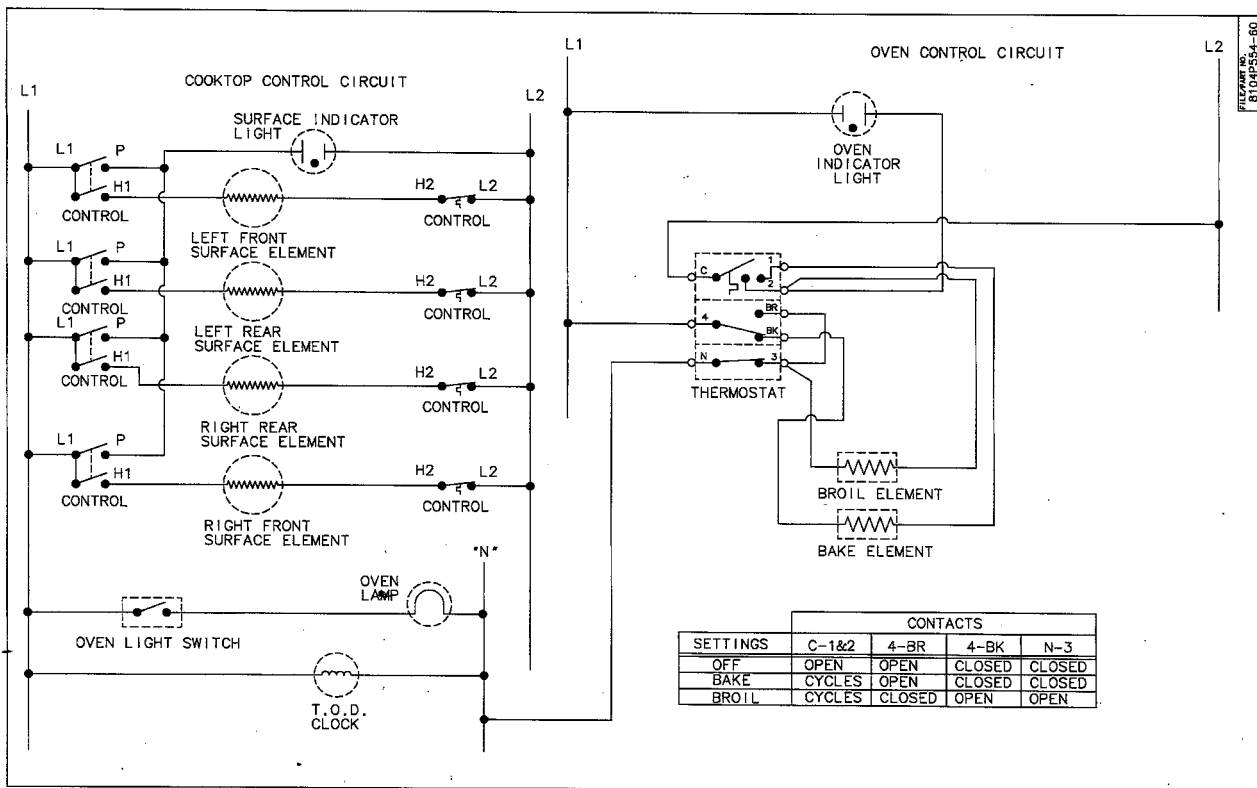
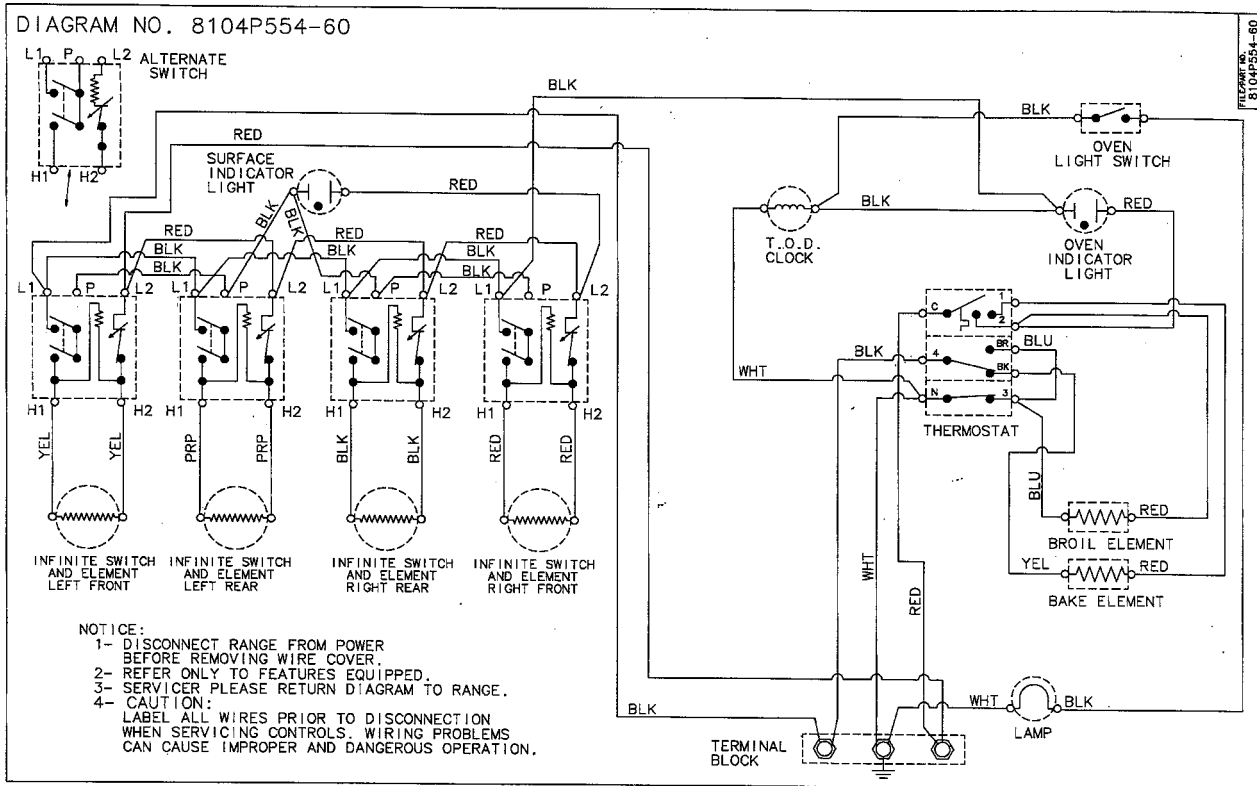

ARE1350AMH AER1360AGW

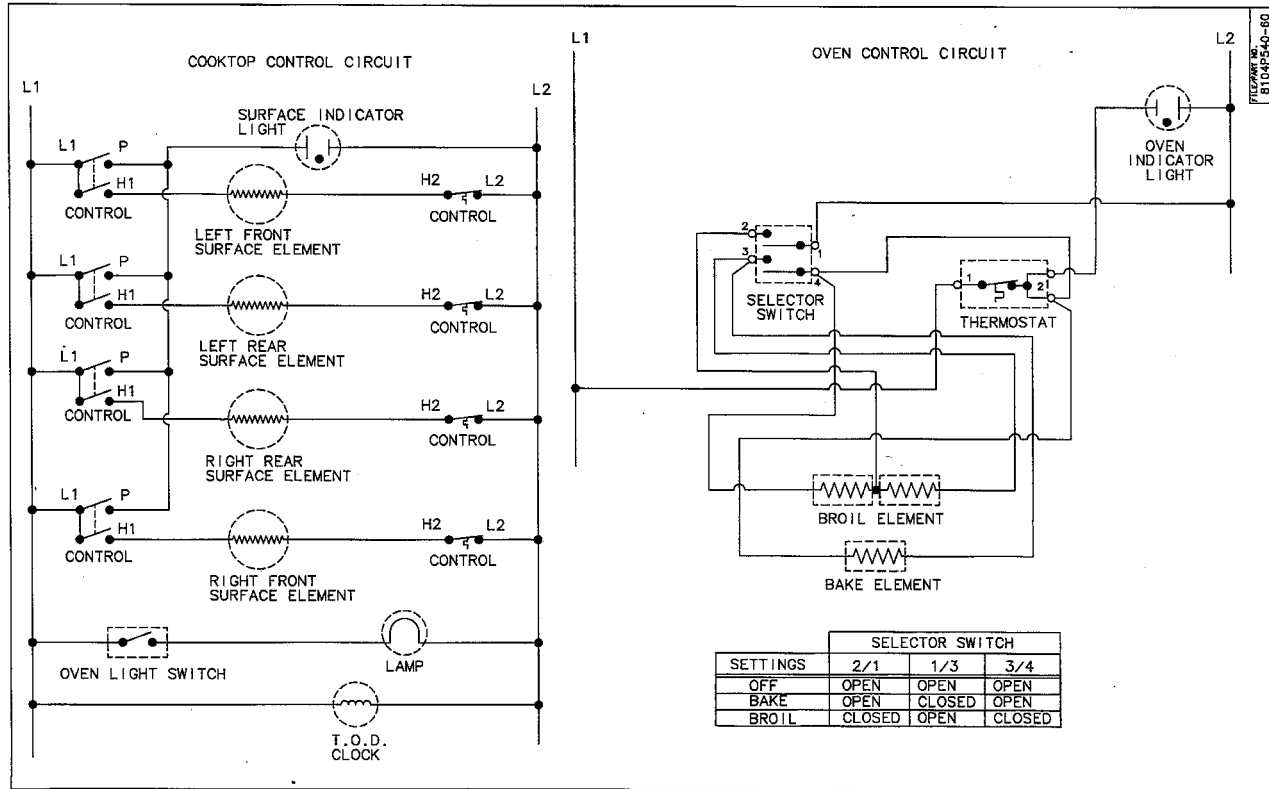
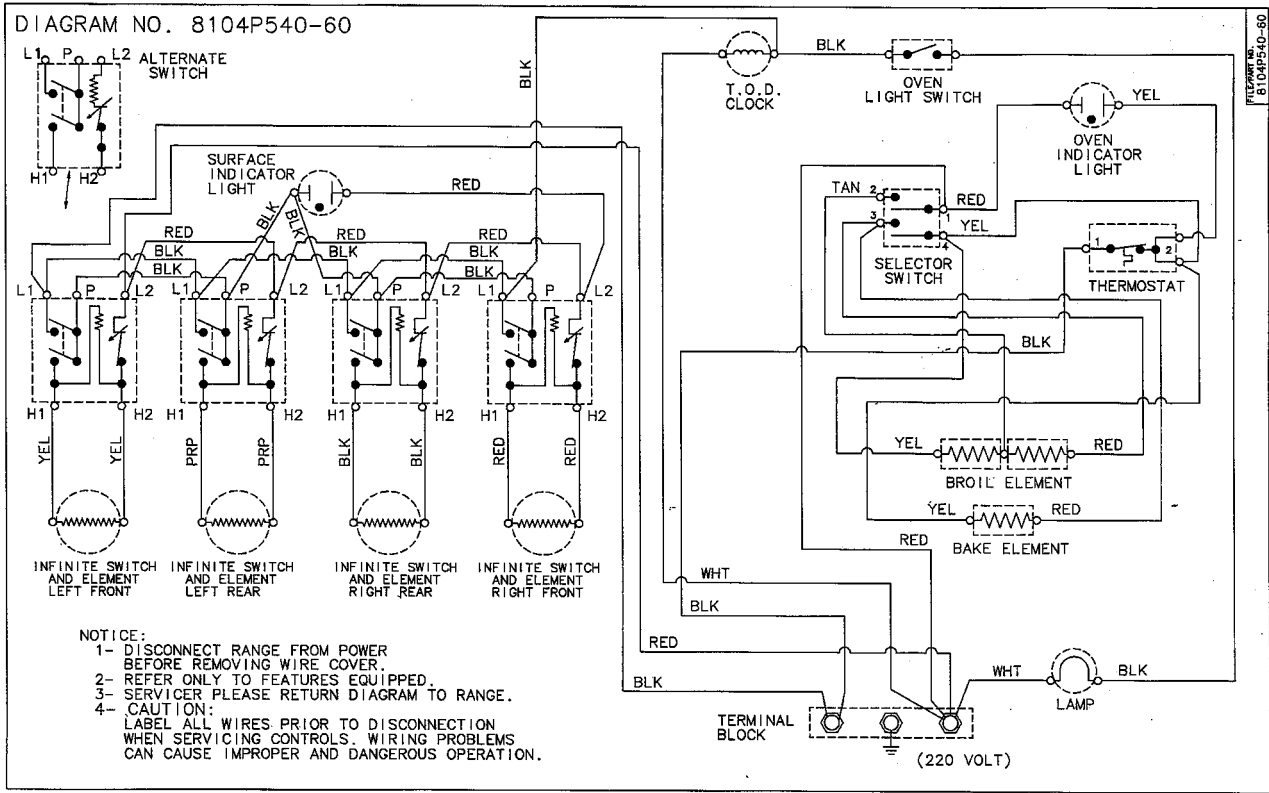

AER1450AAH

DIAGRAM NO. 8104P558-60

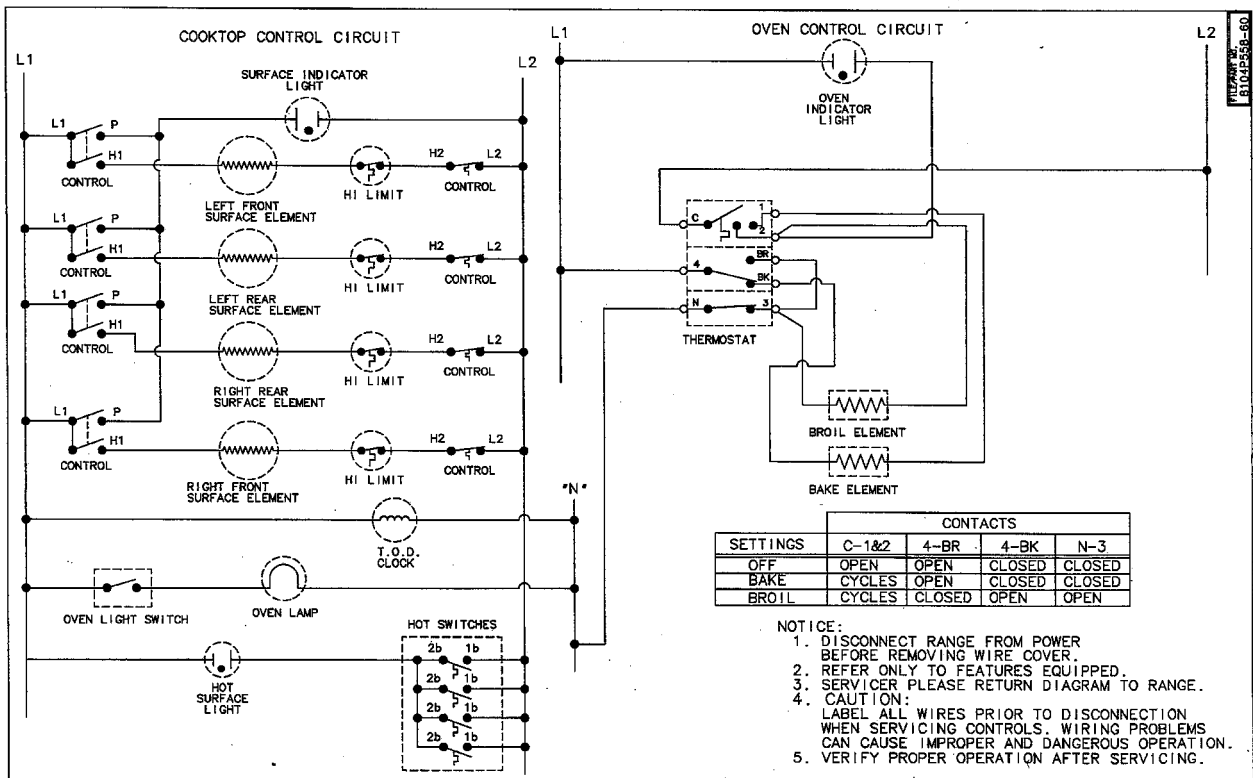
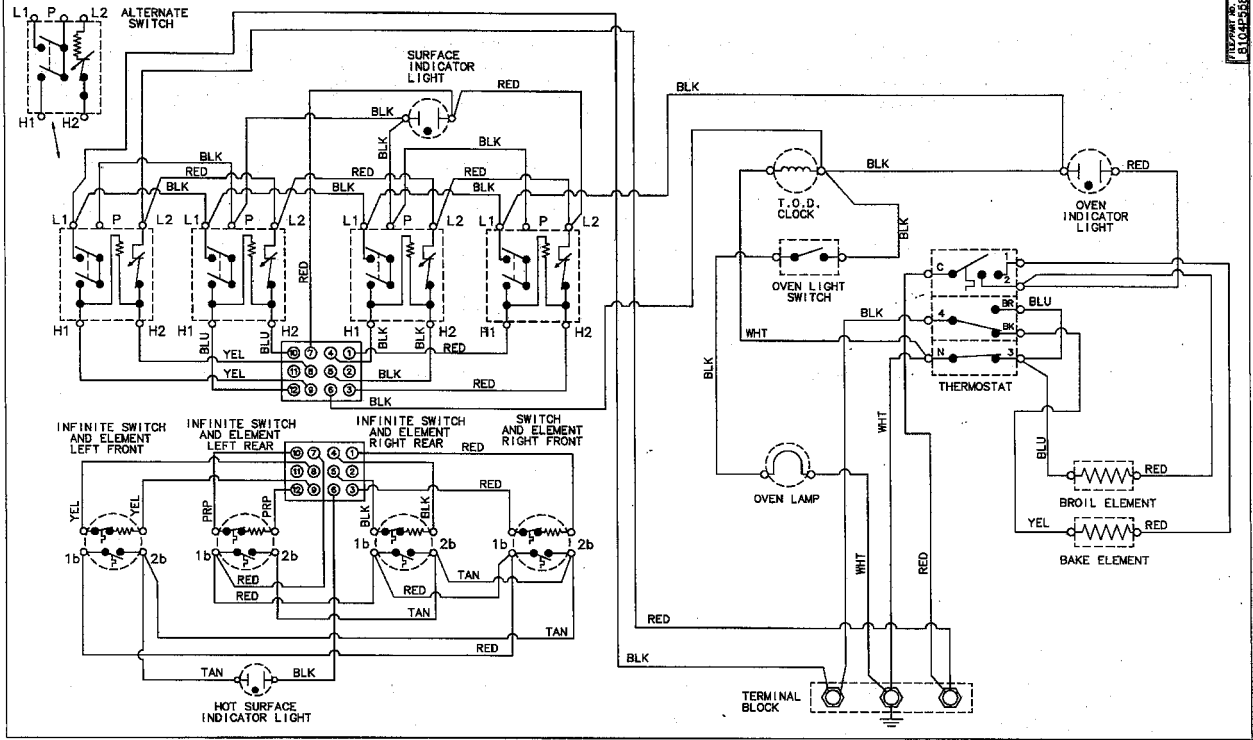



IMPORTANT

Wiring information in this manual was accurate at the time of manual production. Wiring information is subject to change at any time. Please refer to wiring information on the actual product for most current information.

*Because of the simple design of this appliance, wiring is minimal. No engineering diagrams are available. Please refer to information supplied with the unit.

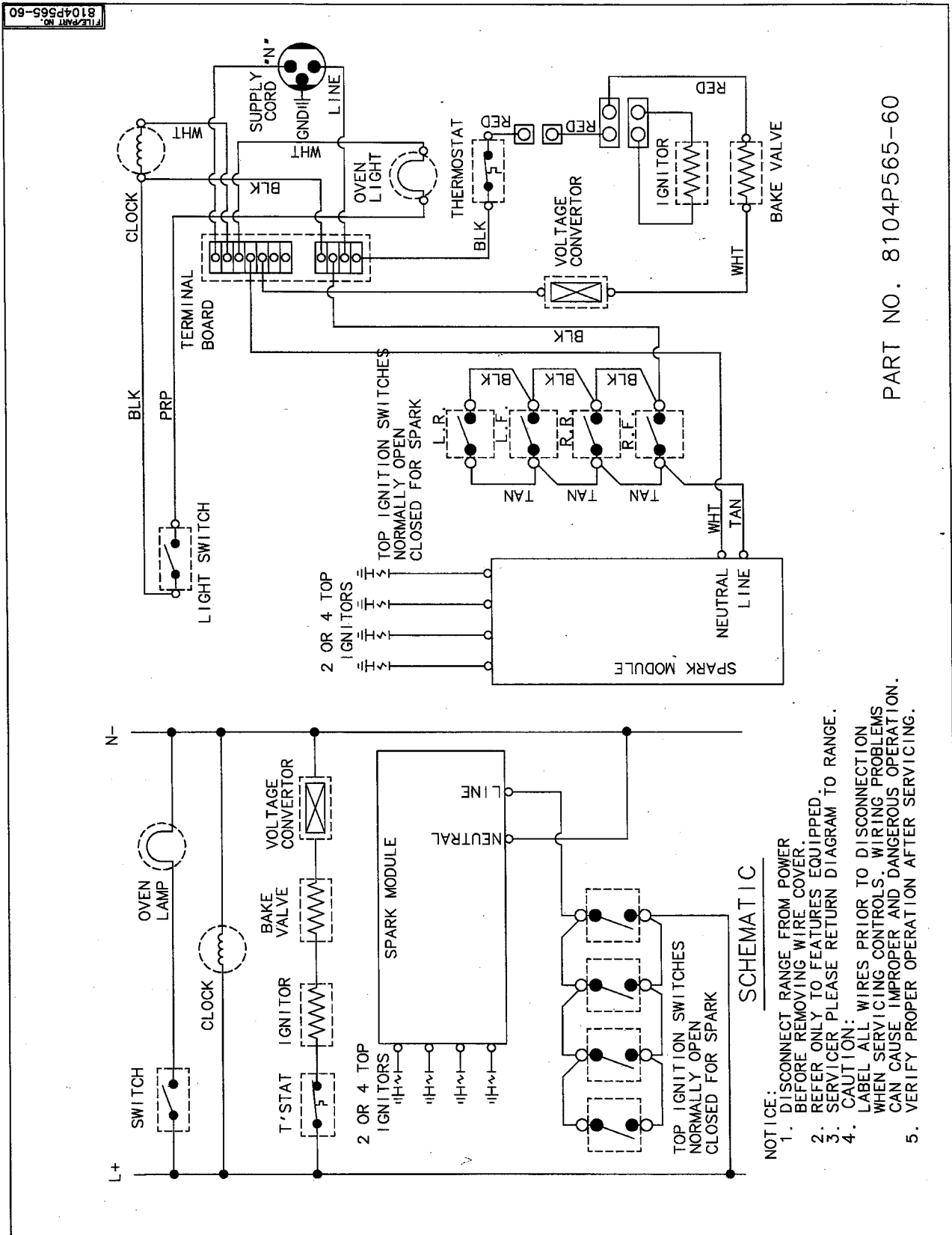

PART NO. 8104P565-60

**International Crosley Model:
CG3111SXAW**

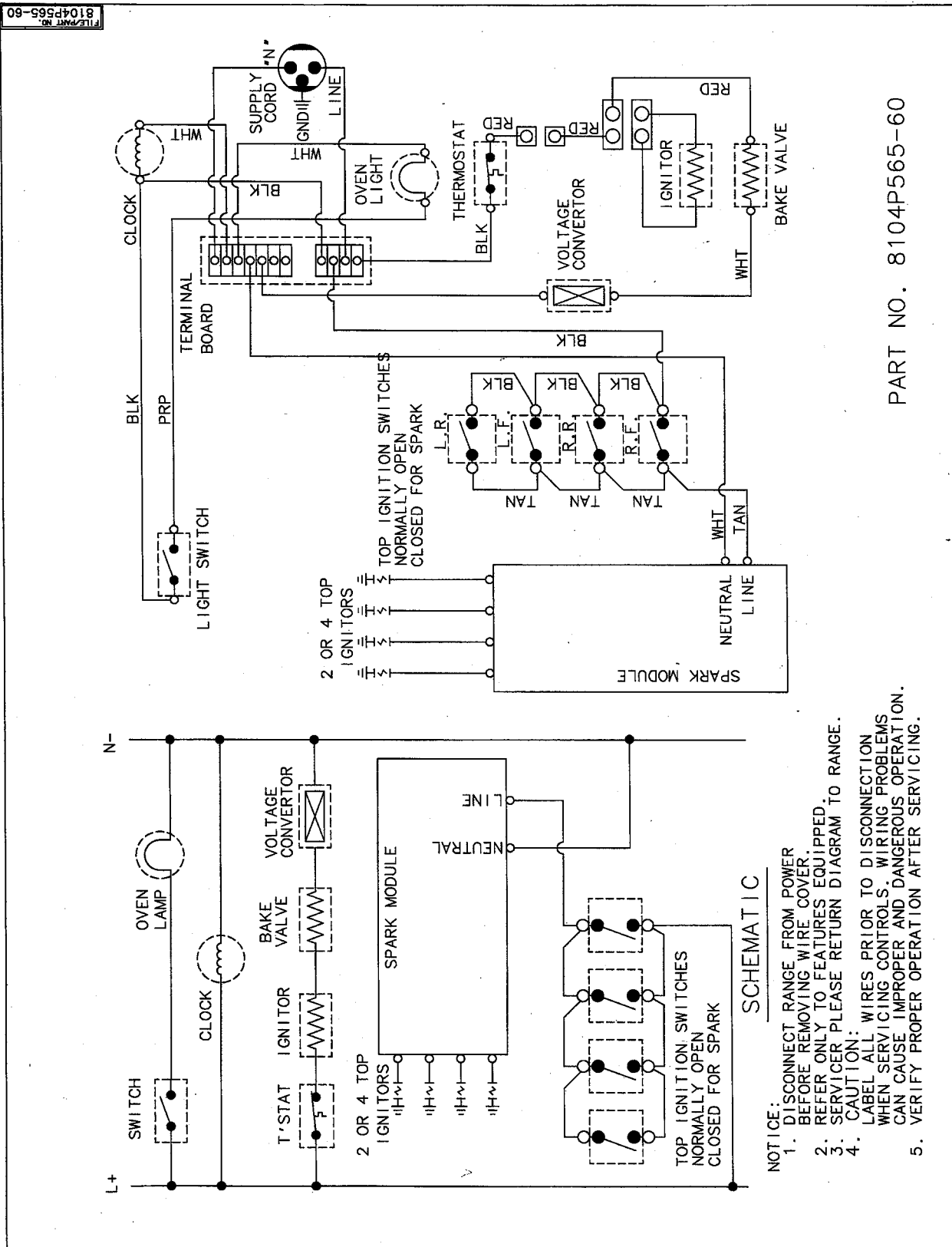

PART NO. 8104P565-60

**International Magic Chef Models:
GM3110MXAW**

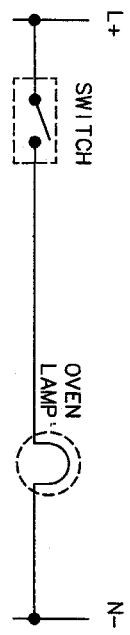

SCHEMATIC

- NOTICE:**
- 1- DISCONNECT RANGE FROM POWER BEFORE REMOVING WIRE COVER.
 - 2- REFER ONLY TO FEATURES EQUIPPED.
 - 3- SERVICER PLEASE RETURN DIAGRAM TO RANGE.
 - 4- CAUTION: LABEL ALL WIRES PRIOR TO DISCONNECTION WHEN SERVICING CONTROLS. WIRING PROBLEMS CAN CAUSE IMPROPER AND DANGEROUS OPERATION.

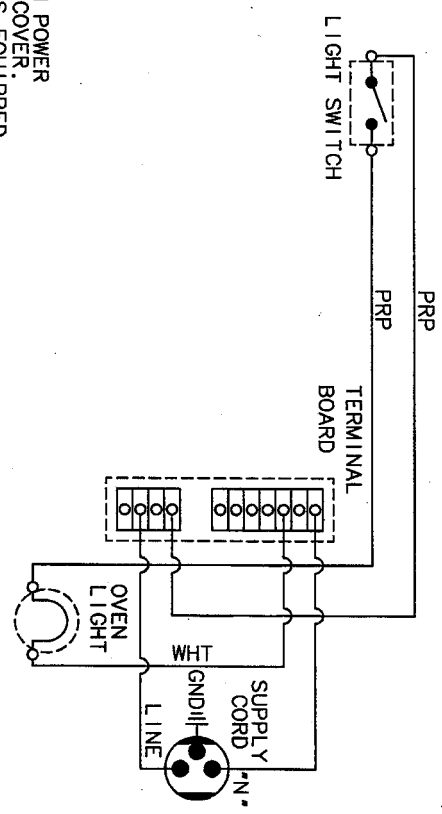

PART NO. 8104P531-60

FILE/PART NO.
8104P531-60

GM3111GXAW GM3111SXAW GM31113WAV GM31211XAW

FILE/PART NO. 8104P565-60

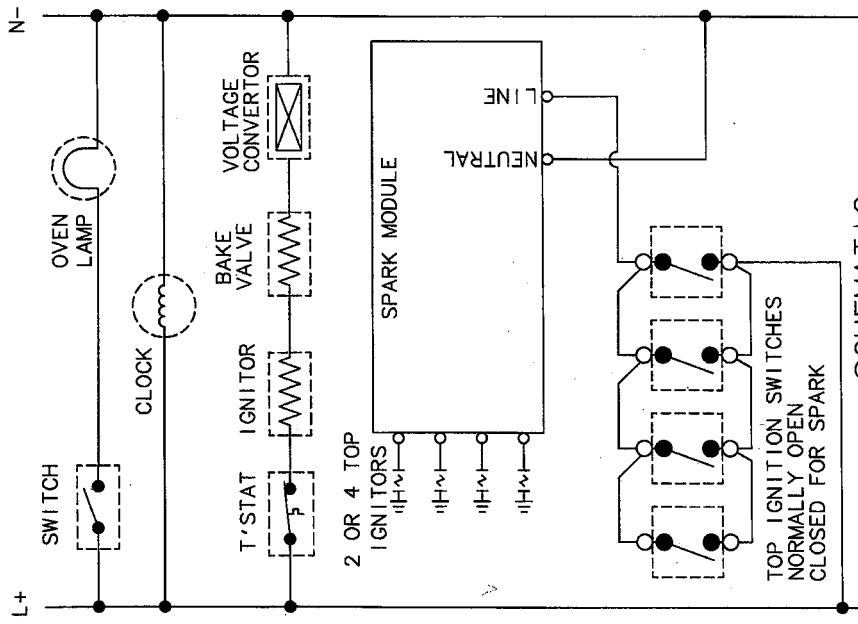
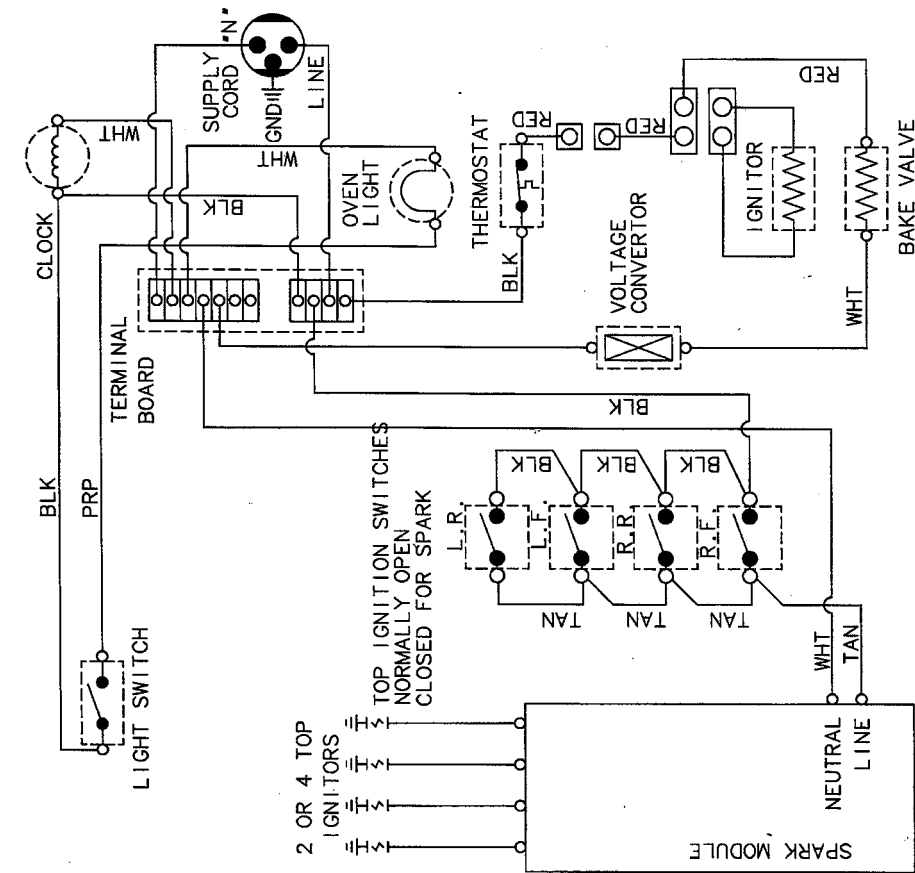

SCHEMATIC

- NOTICE:
1. DISCONNECT RANGE FROM POWER BEFORE REMOVING WIRE COVER.
 2. REFER ONLY TO FEATURES EQUIPPED.
 3. SERVICER PLEASE RETURN DIAGRAM TO RANGE.
 4. CAUTION: LABEL ALL WIRES PRIOR TO DISCONNECTION WHEN SERVICING CONTROLS. WIRING PROBLEMS CAN CAUSE IMPROPER AND DANGEROUS OPERATION.
 5. VERIFY PROPER OPERATION AFTER SERVICING.

PART NO. 8104P565-60

CER1360AGW

DIAGRAM NO. 8104P558-60

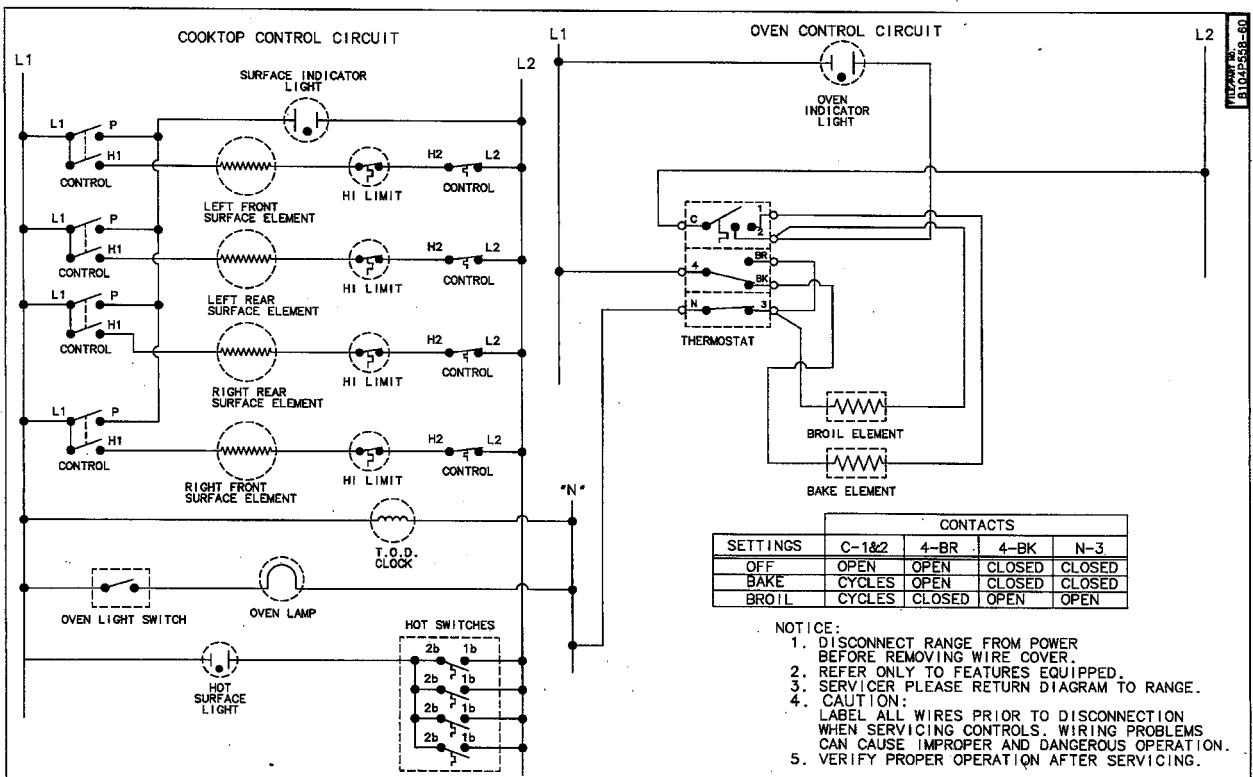
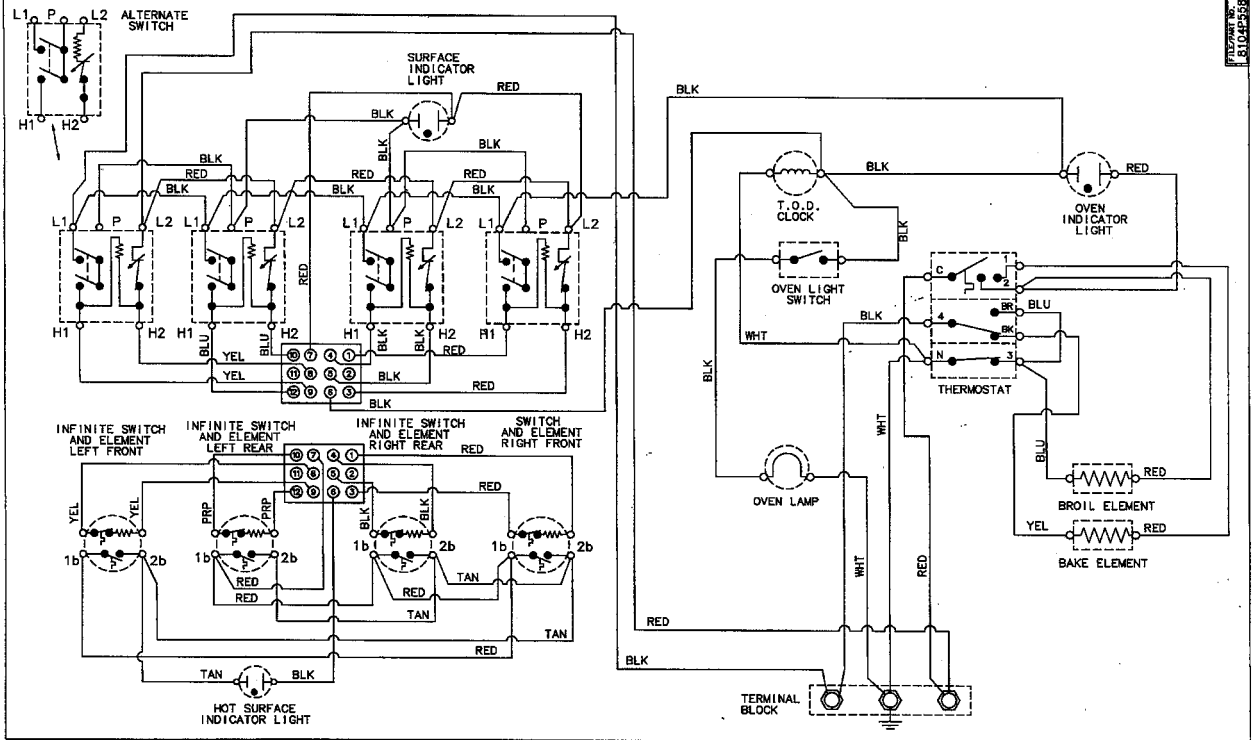

CER3520AGW

DIAGRAM NO. 8104P544-60

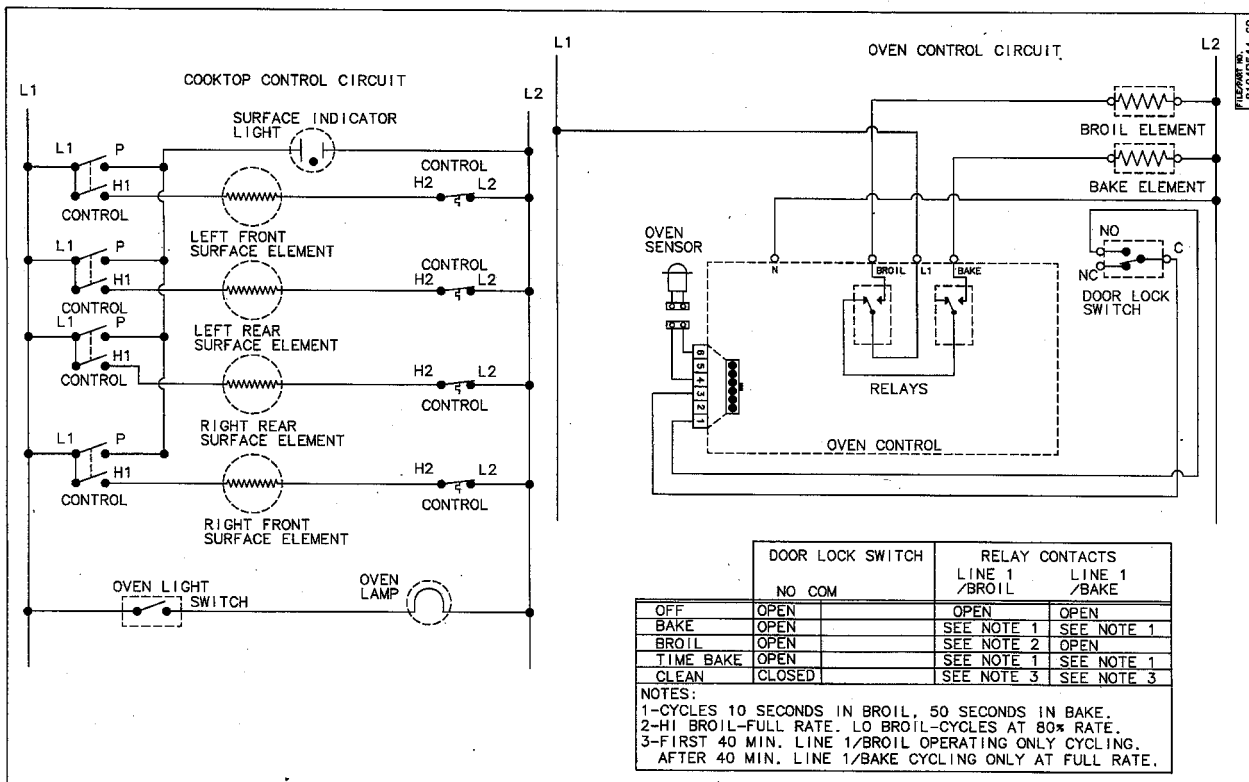
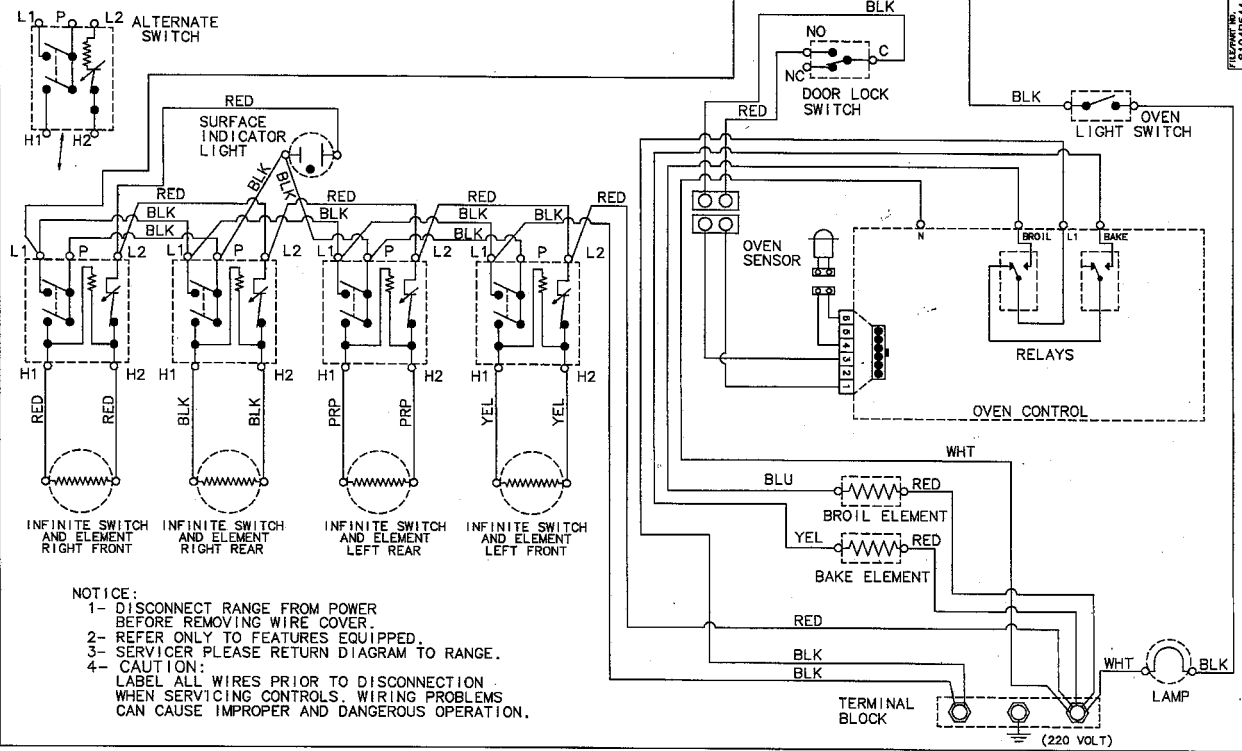

CBR3765AGC

DIAGRAM NO. 8104P594-60

- NOTICE:**
1. DISCONNECT RANGE FROM POWER BEFORE REMOVING WIRE COVER.
 2. REFER ONLY TO FEATURES EQUIPPED.
 3. SERVICER PLEASE RETURN DIAGRAM TO RANGE.
 4. CAUTION: LABEL ALL WIRES PRIOR TO DISCONNECTION WHEN SERVICING CONTROLS. WIRING PROBLEMS CAN CAUSE IMPROPER AND DANGEROUS OPERATION.
 5. VERIFY PROPER OPERATION AFTER SERVICING.

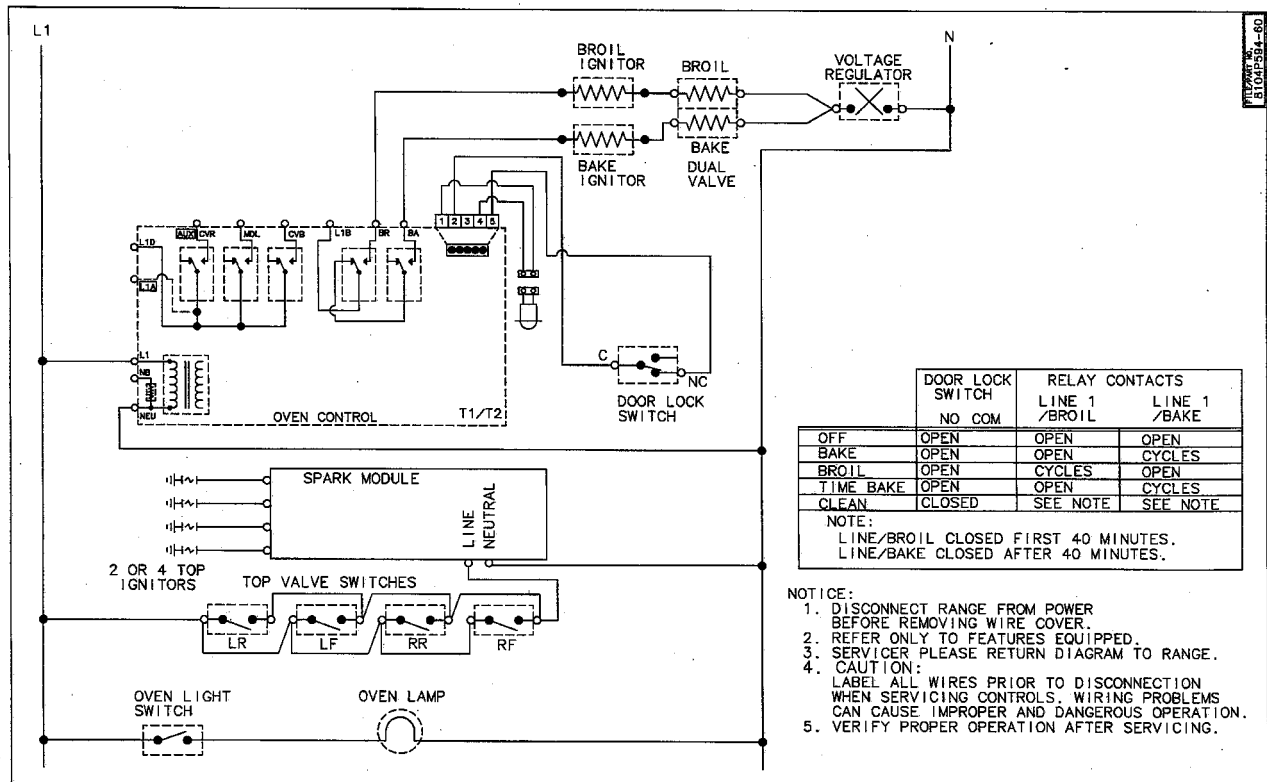
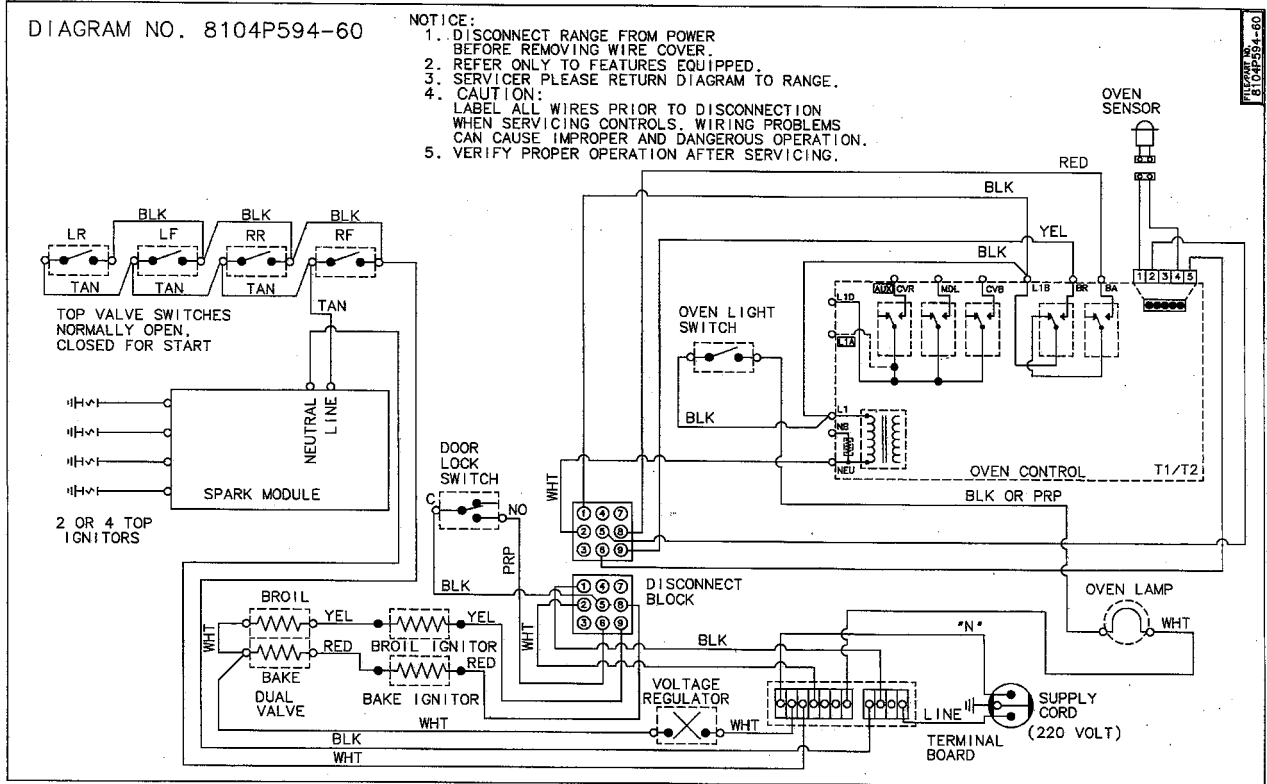

	DOOR LOCK SWITCH		RELAY CONTACTS	
	NO	COM	LINE 1 / BROIL	LINE 1 / BAKE
OFF	OPEN	OPEN	OPEN	OPEN
BAKE	OPEN	OPEN	OPEN	CYCLES
BROIL	OPEN	OPEN	CYCLES	OPEN
TIME BAKE	OPEN	OPEN	OPEN	CYCLES
CLEAN	CLOSED	SEE NOTE	SEE NOTE	SEE NOTE

NOTE:
 LINE/BROIL CLOSED FIRST 40 MINUTES.
 LINE/BAKE CLOSED AFTER 40 MINUTES.

- NOTICE:**
1. DISCONNECT RANGE FROM POWER BEFORE REMOVING WIRE COVER.
 2. REFER ONLY TO FEATURES EQUIPPED.
 3. SERVICER PLEASE RETURN DIAGRAM TO RANGE.
 4. CAUTION: LABEL ALL WIRES PRIOR TO DISCONNECTION WHEN SERVICING CONTROLS. WIRING PROBLEMS CAN CAUSE IMPROPER AND DANGEROUS OPERATION.
 5. VERIFY PROPER OPERATION AFTER SERVICING.

**International Maytag Models:
MBR4450BGH MBR4450BGW**

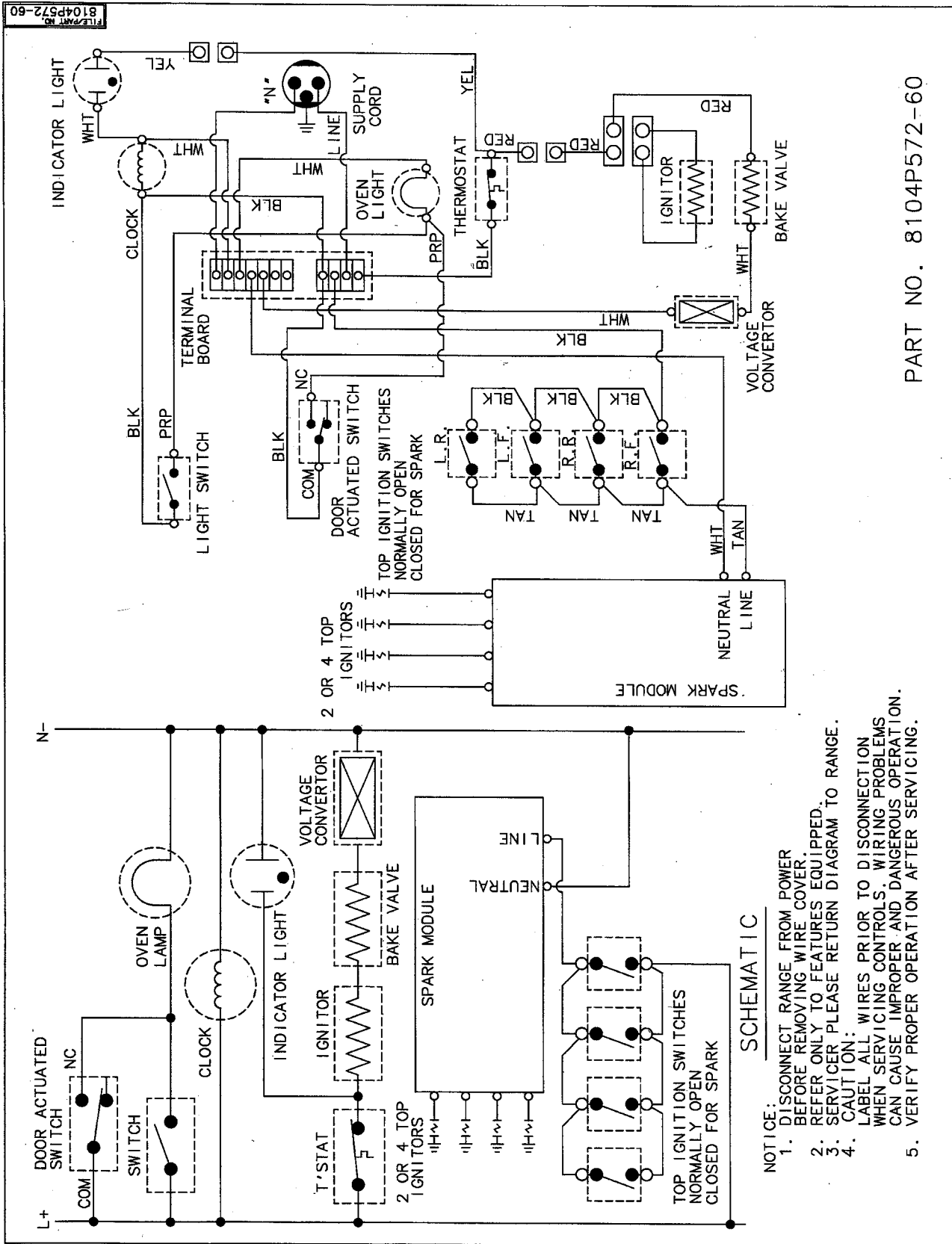

MBR5750AGW

DIAGRAM NO. 8104P593-60

- NOTICE:
1. DISCONNECT RANGE FROM POWER BEFORE REMOVING WIRE COVER.
 2. REFER ONLY TO FEATURES EQUIPPED.
 3. SERVICER PLEASE RETURN DIAGRAM TO RANGE.

4. CAUTION: LABEL ALL WIRES PRIOR TO DISCONNECTION WHEN SERVICING CONTROLS. WIRING PROBLEMS CAN CAUSE IMPROPER AND DANGEROUS OPERATION.
5. VERIFY PROPER OPERATION AFTER SERVICING.

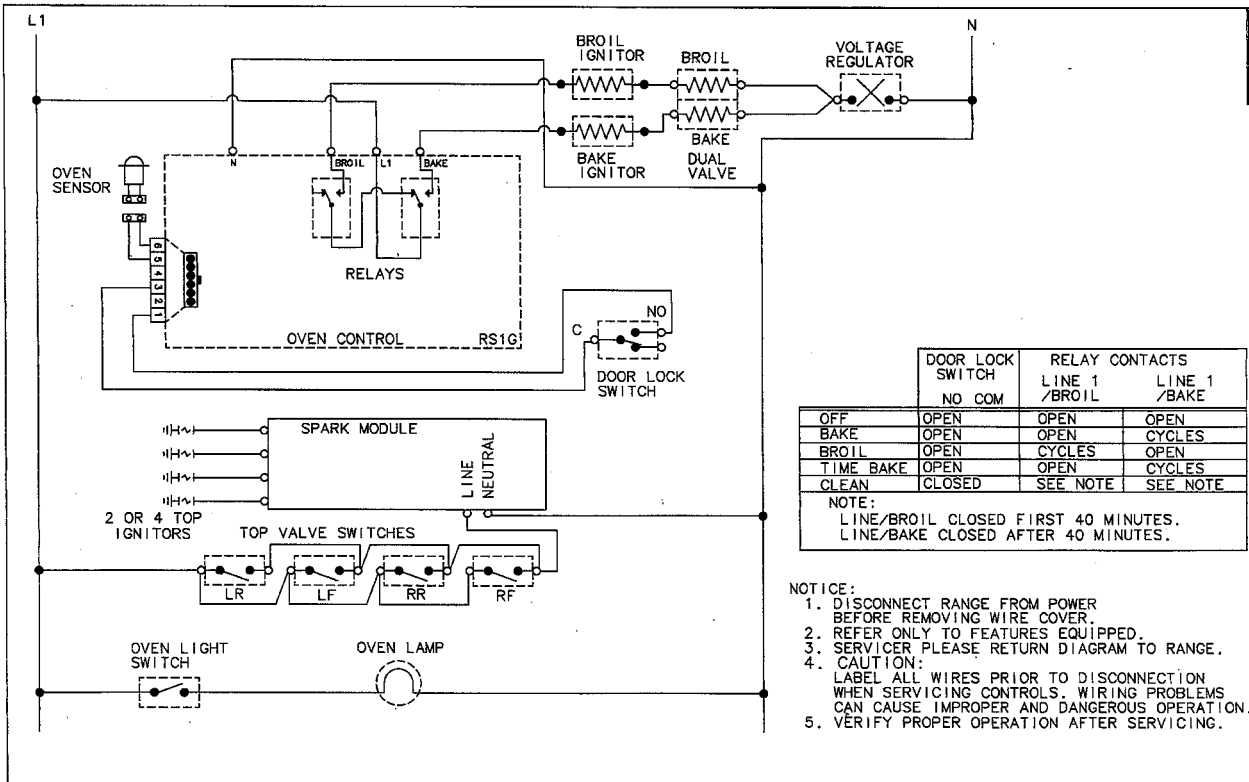
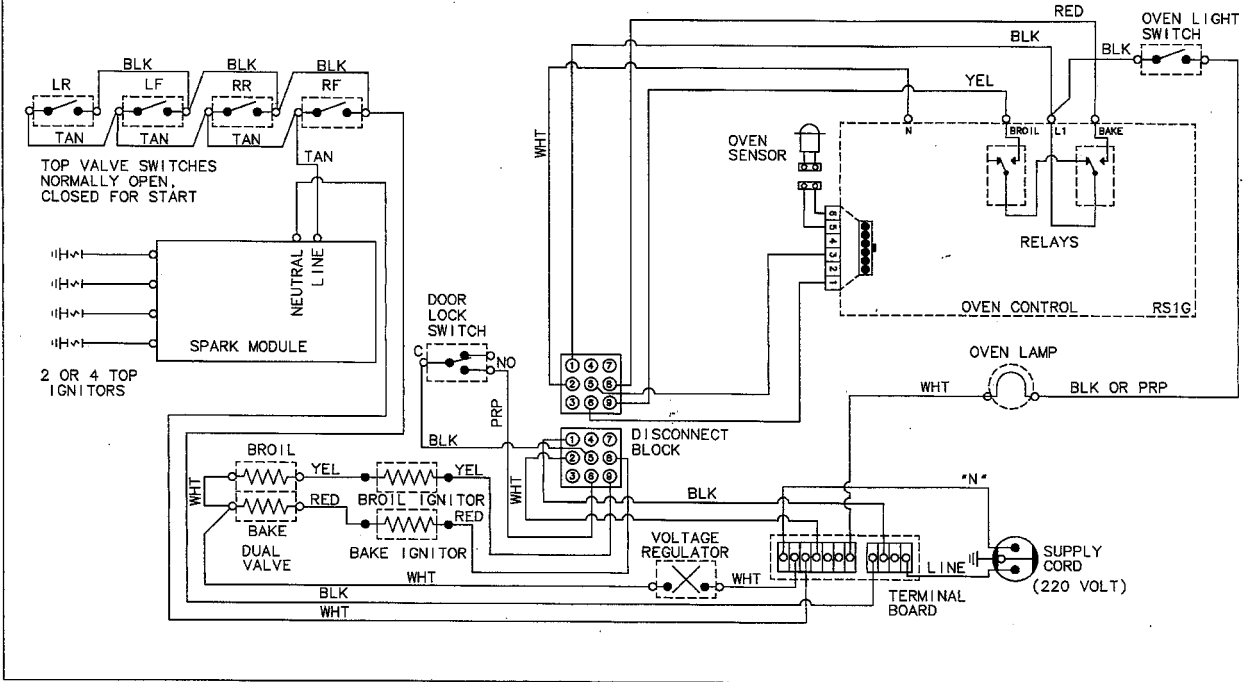

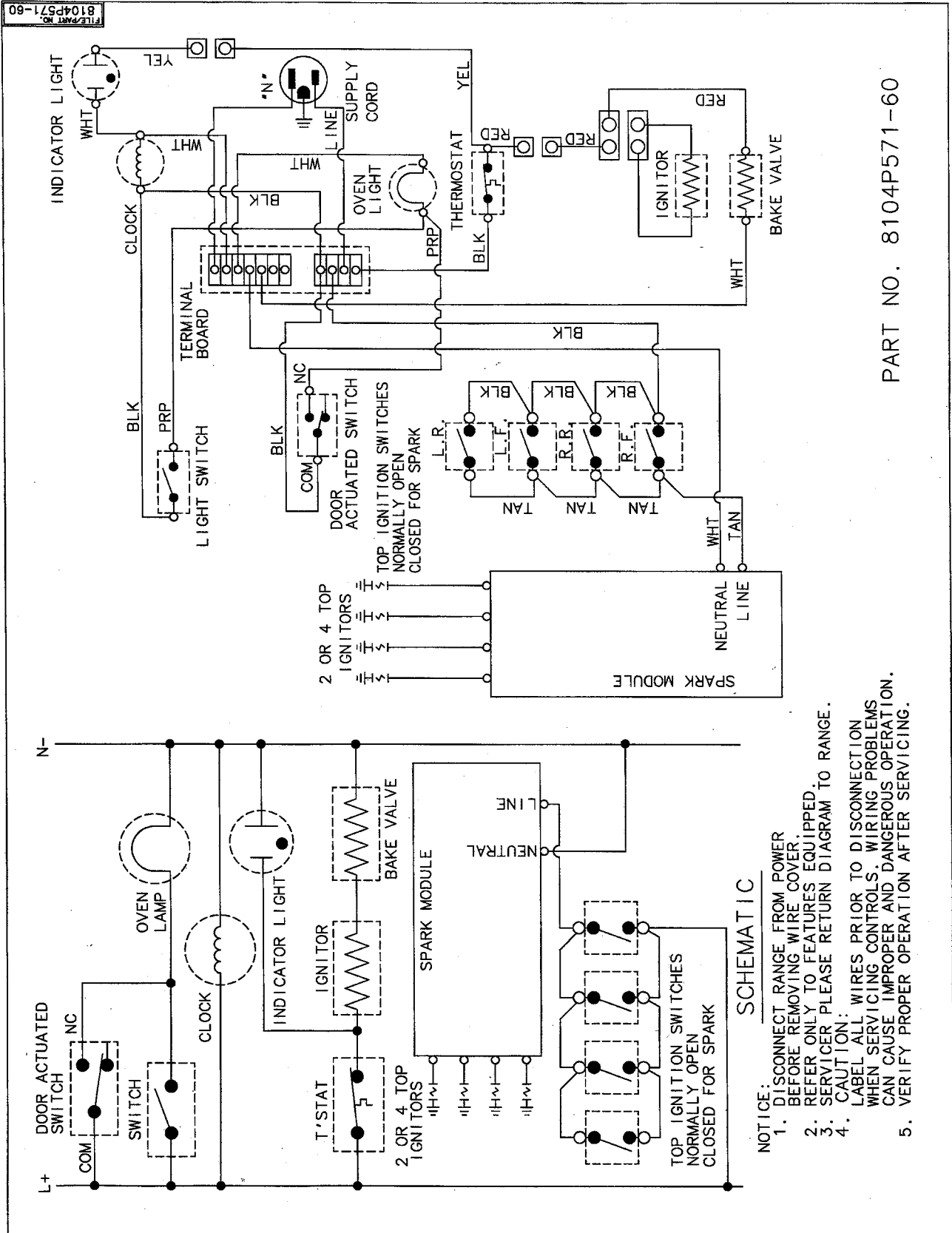

PART NO. 8104P571-60

MER4320AGH MER4320AGW

DIAGRAM NO. 8104P541-60

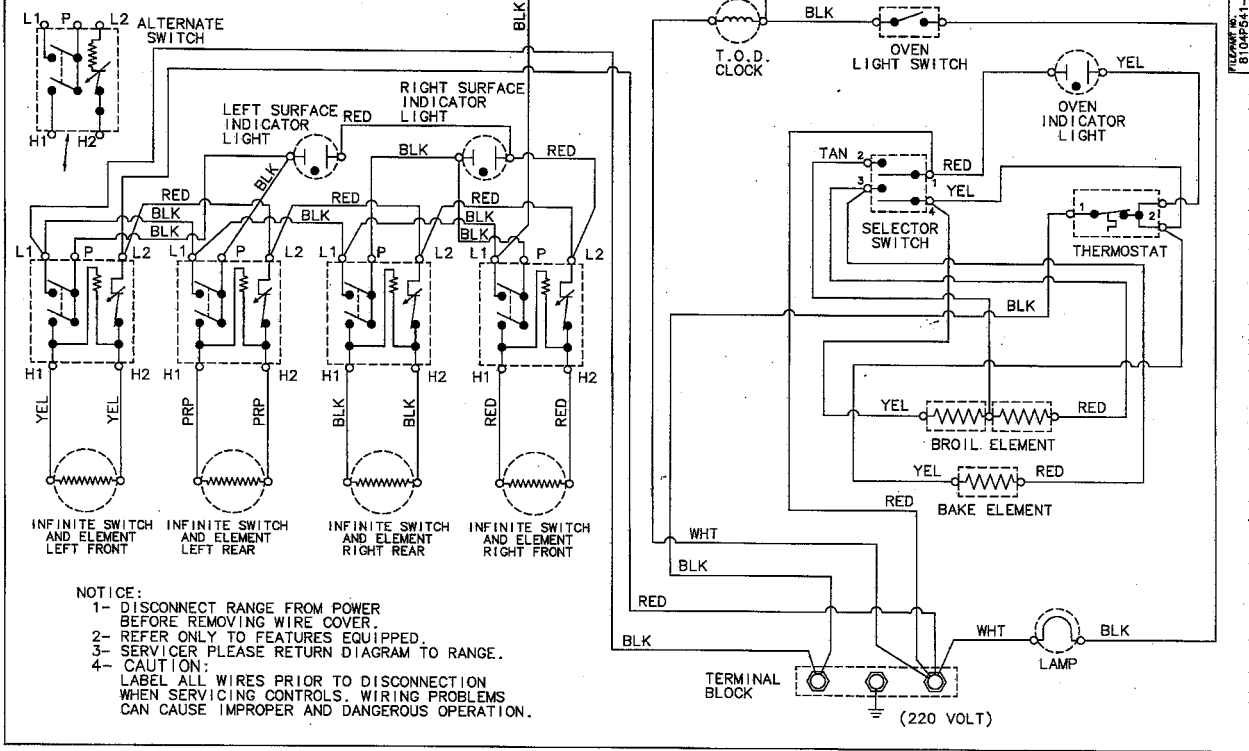

NOTICE:
 1- DISCONNECT RANGE FROM POWER BEFORE REMOVING WIRE COVER.
 2- REFER ONLY TO FEATURES EQUIPPED.
 3- SERVICER PLEASE RETURN DIAGRAM TO RANGE.
 4- CAUTION: LABEL ALL WIRES PRIOR TO DISCONNECTION WHEN SERVICING CONTROLS. WIRING PROBLEMS CAN CAUSE IMPROPER AND DANGEROUS OPERATION.

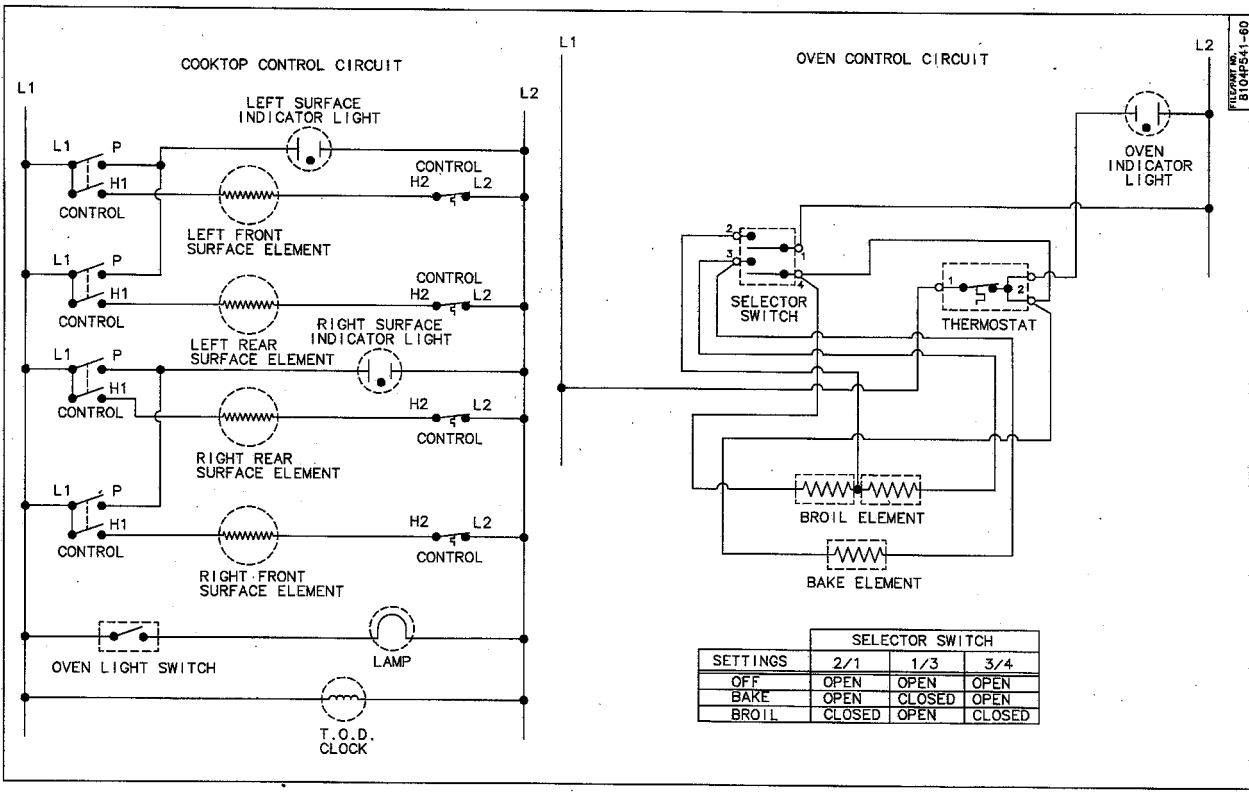

MER5730AGW

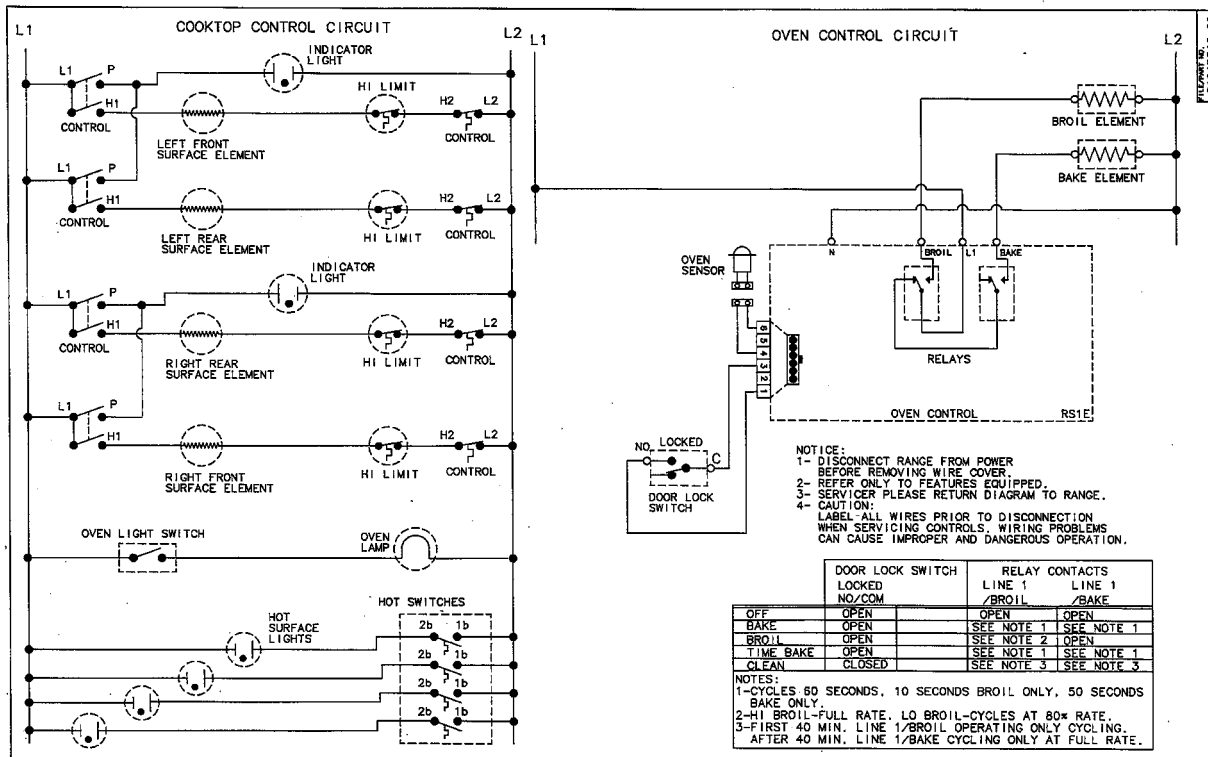
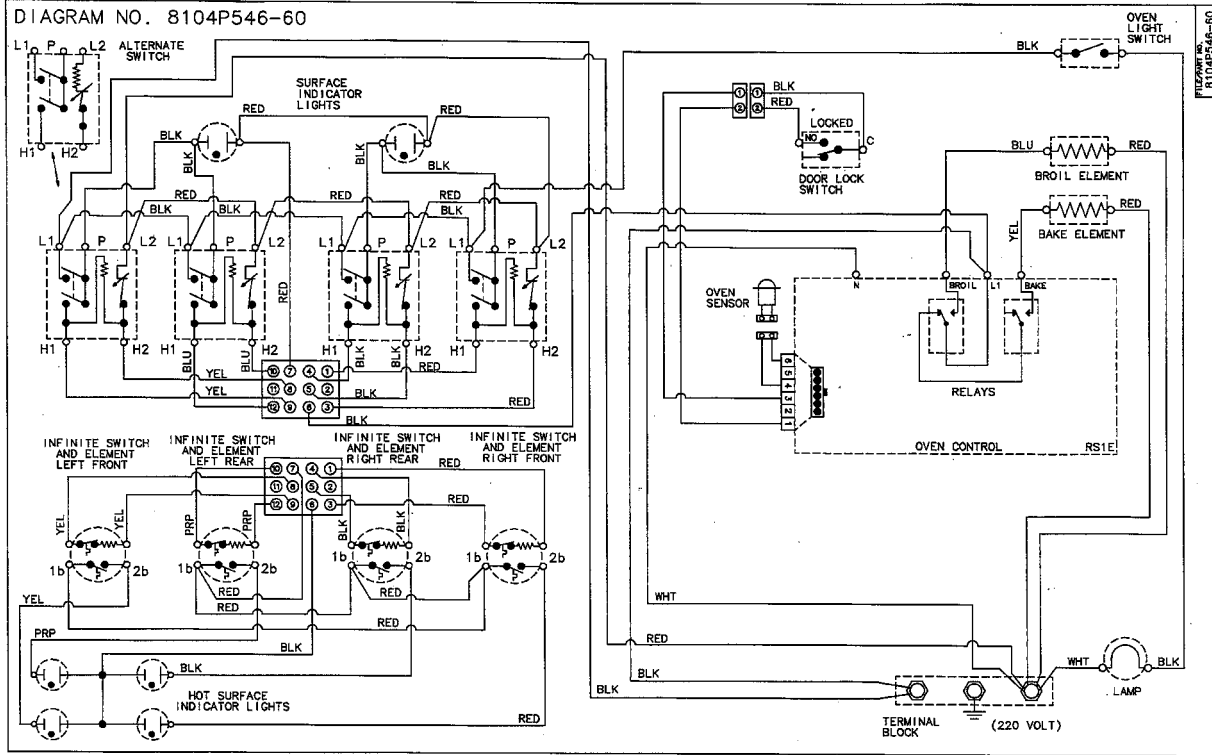



IMPORTANT

Wiring information in this manual was accurate at the time of manual production. Wiring information is subject to change at any time. Please refer to wiring information on the actual product for most current information.

*Because of the simple design of this appliance, wiring is minimal. No engineering diagrams are available. Please refer to information supplied with the unit.

International Norge Model: NER1360AGH

DIAGRAM NO. 8104P540-60

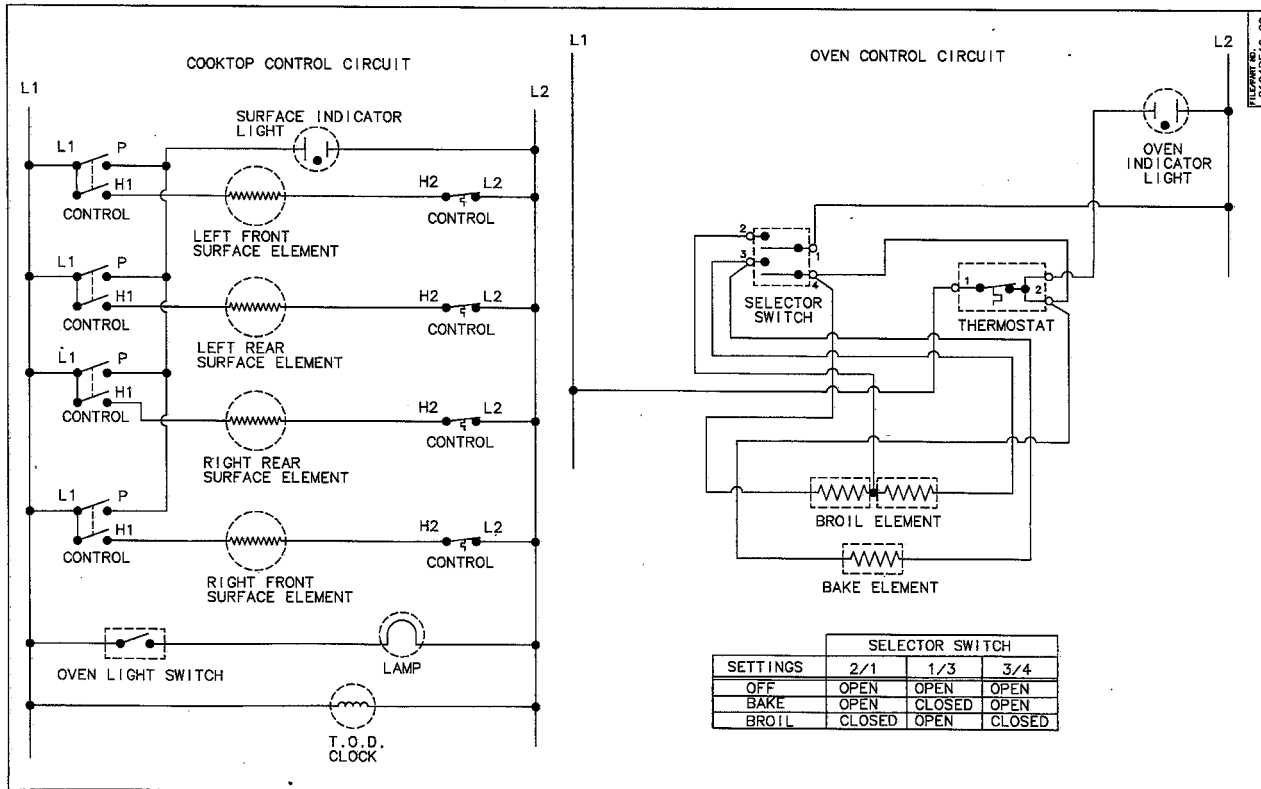
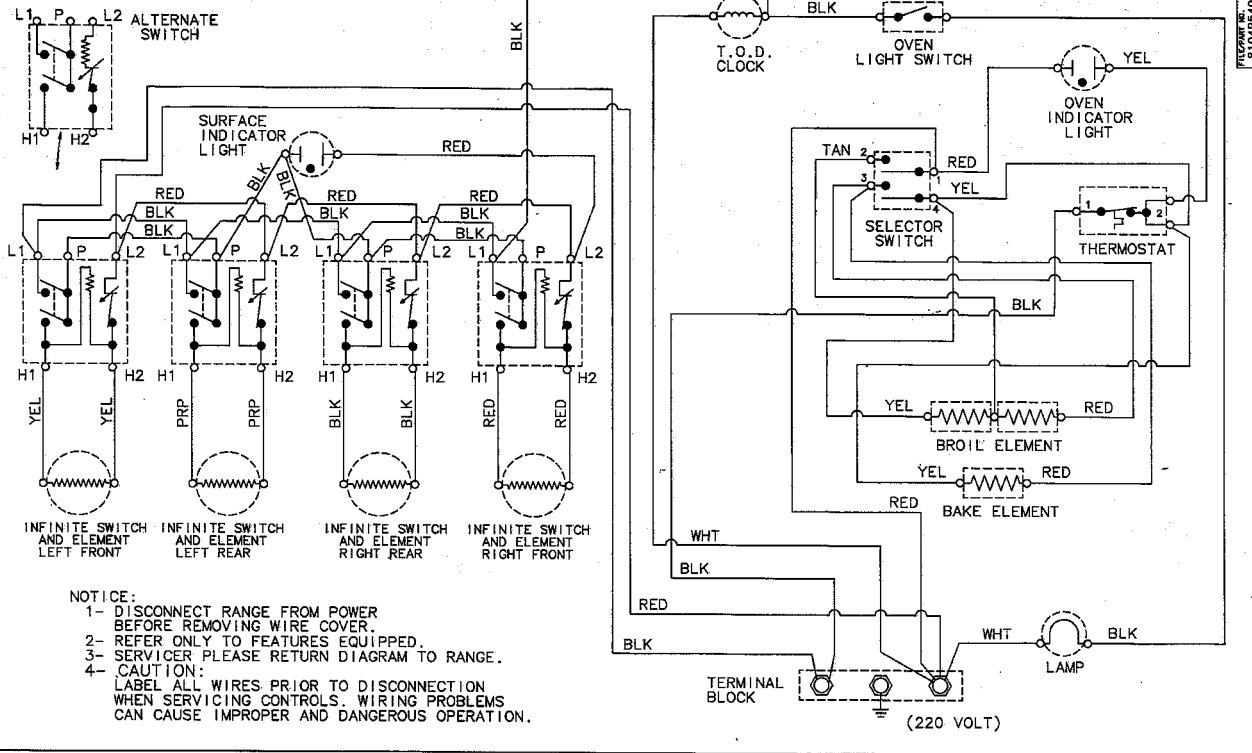

**International Dixie Models:
D31113XAT D31113XAWL**

FILE/PART NO. 8104P564-60

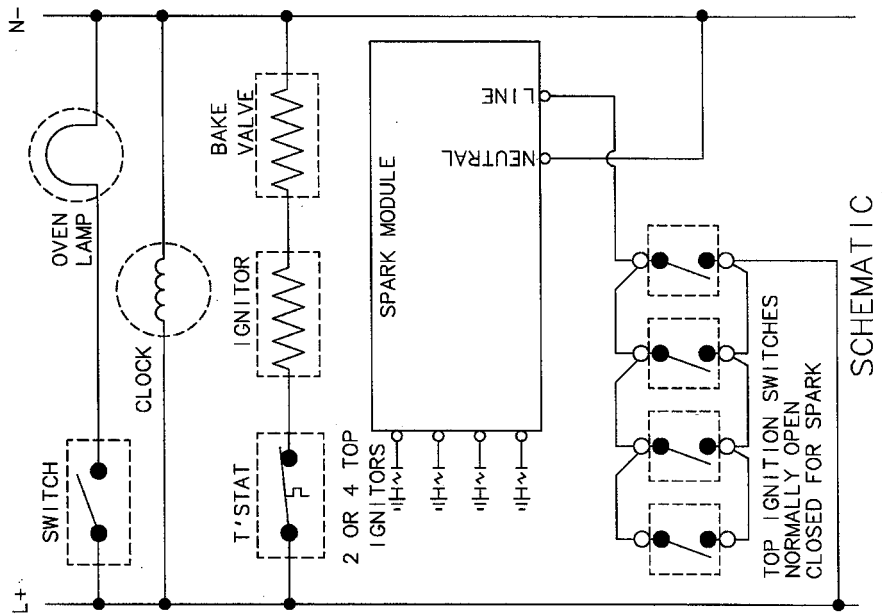
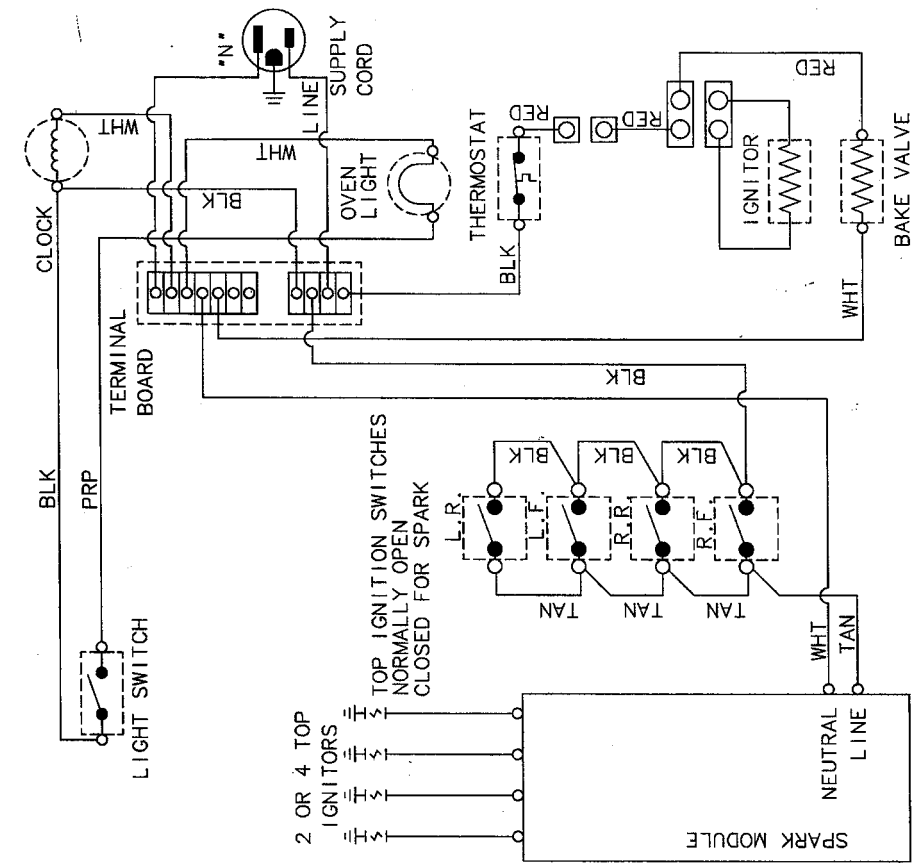

- NOTICE:**
1. DISCONNECT RANGE FROM POWER BEFORE REMOVING WIRE COVER.
 2. REFER ONLY TO FEATURES EQUIPPED.
 3. SERVICER PLEASE RETURN DIAGRAM TO RANGE.
 4. CAUTION: LABEL ALL WIRES PRIOR TO DISCONNECTION WHEN SERVICING CONTROLS. WIRING PROBLEMS CAN CAUSE IMPROPER AND DANGEROUS OPERATION.
 5. VERIFY PROPER OPERATION AFTER SERVICING.

PART NO. 8104P564-60



IMPORTANT

Wiring information in this manual was accurate at the time of manual production. Wiring information is subject to change at any time. Please refer to wiring information on the actual product for most current information.

*Because of the simple design of this appliance, wiring is minimal. No engineering diagrams are available. Please refer to information supplied with the unit.

MAYTAG

Maytag Appliances Sales Company
240 Edwards St. S.E.
Cleveland, TN 37311