

KITCHENAID ELECTRONIC RANGE CONTROLS

“B” & “D” LINE WALL OVENS

JOB AID
Part No. 4317169

FORWARD

This Job Aid is a reference guide for the experienced technician. It is not designed as a replacement to basic training, and does not replace the Service Manual or the Use and Care Guide.

OBJECTIVE

The objective of this Job Aid is to allow the experienced appliance technician to become familiar with the operation of the KitchenAid Electronic Range Control. This Job Aid follows the instructions contained on the companion training disk, and is designed as reference material.

WHIRLPOOL CORPORATION assumes no responsibility for any repair made on our products by anyone other than Authorized Factory Service Technicians.

Copyright 1995 Whirlpool Corporation

Table of Contents

KitchenAid Electronic Range Controls—"B" Line Slide-In	Page 2
KitchenAid Electronic Range Controls—"B" Line Freestanding	Page 4
KitchenAid Electronic Range Controls—"B" Line Freestanding/Slide-In	Page 6
KitchenAid Electronic Range Controls—"D" Line Wall Ovens	Page 7
Reading The Graphic Display	Page 12
KitchenAid Electronic Range Controls—"Easy Convect"	Page 13
KitchenAid Electronic Range Controls—"Easy Convect (Meats)"	Page 14
KitchenAid Electronic Range Controls—"Sabbath Mode"	Page 23
KitchenAid Electronic Range Controls—"Clean Mode"	Page 32

— NOTES —

Important Safety Information

This manual is intended for factory-service technicians only. We recommend that customers DO NOT service their own units, because of the complexity and risk of high-voltage electrical shock.

The following information is used throughout this manual, and should be read carefully.

NOTE

Helpful information that explains a more complicated step, prior to carrying it out .

⚠ CAUTION

Information that will help you avoid actions that could cause product damage (scratches, dents, etc.) and damage to personal property.

⚠ WARNING

Information that alerts you to potentially dangerous conditions. These conditions can cause serious personal injury (burns, fire and electrical shock, etc.) if the suggested procedures are not observed.

⚠ WARNING

Fire Hazard

Do not obstruct the flow of ventilation air.

Electrical Shock Hazard

It is the customer's responsibility to:

- Contact a qualified electrical installer.
- Assure that electrical installation is adequate and in conformance with the National Electrical Code, ANSI/NFPA 70—latest edition*, and all local codes and ordinances.

Failure to do so could result in fire, electrical shock, or other personal injury.

Take special care when drilling holes into the wall for venting or electrical wiring. Electrical wires may be concealed behind the wall covering.

Failure to do so could result in fire, electrical shock, or other personal injury.

* National Fire Protection Association
Batterymarch Park
Quincy, Massachusetts 02269

KitchenAid ASSUMES NO RESPONSIBILITY FOR ANY REPAIRS MADE ON OUR PRODUCTS BY ANYONE OTHER THAN AUTHORIZED **KitchenAid**SM SERVICE TECHNICIANS.

Installation Layout

SLIDE-IN ELECTRIC RANGES

Refer to Figure 1 while you read the following installation information.

Proper installation is your responsibility. A qualified technician must install this range. Make sure you have everything necessary for correct installation. It is the responsibility of the installer to comply with the installation clearances specified on the serial/rating plate. This plate is located behind the oven door at the top of the left front frame. **IMPORTANT:** Be sure to observe all governing codes and ordinances.

Clearance Note: A clearance of 30" (76.2 cm) minimum is required when the bottom of a wood or metal cabinet is protected by not less than 1/4" of flame-retardant millboard covered with not less

than #28 MSG sheet steel, 0.015" stainless steel, 0.024" aluminum, or 0.020" copper. A minimum clearance of 36" (91.4 cm) between the top of the cooking platform and the bottom of an unprotected wood or metal cabinet is required.

The cutout shown is for a 25" (63.5 cm) countertop with a 24" (61 cm) base cabinet and no backsplash. The maximum depth for overhead cabinets is 13" (33 cm). For the minimum vertical clearance between the cooking surface and the overhead cabinets, see the previous "Clearance Note." Overhead cabinets installed at either side of the range must be a minimum of 18" (45.7 cm) above the cooking surface. The minimum horizontal distance between the overhead cabinets is 30" (76.2 cm).

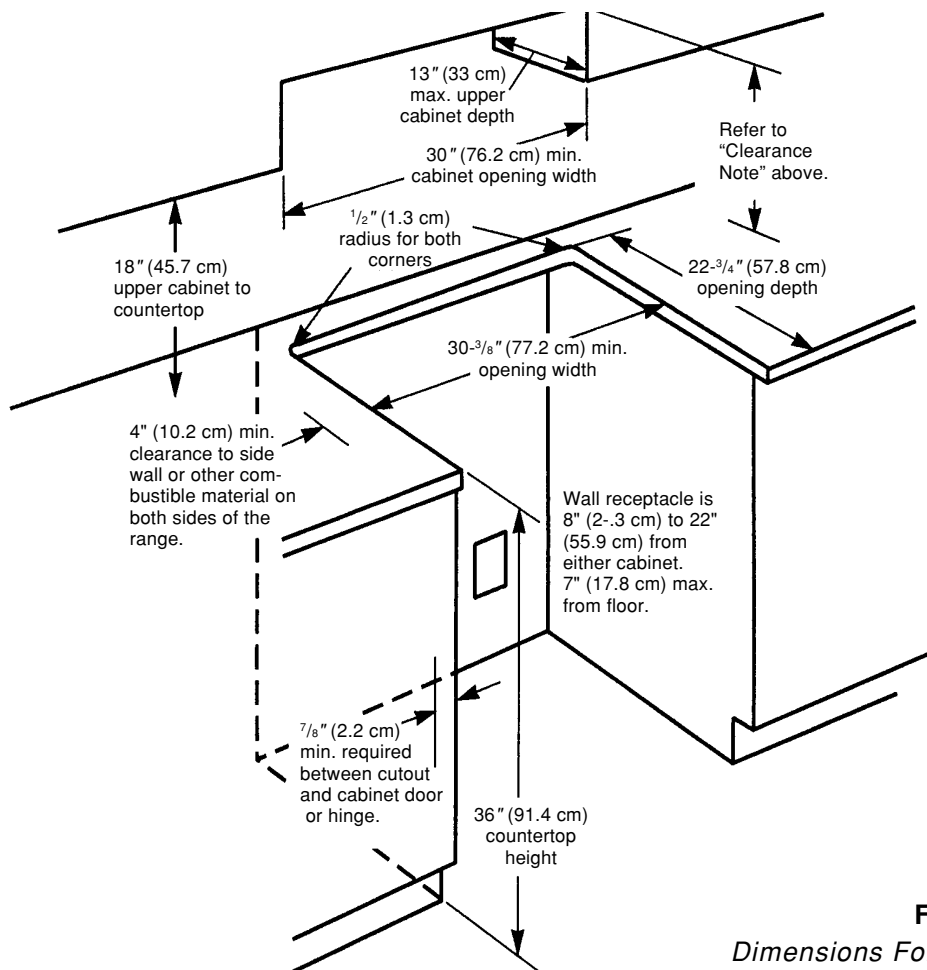

The Anti-Tip bracket **MUST** be installed.

The range should be located away from strong draft areas, such as windows, doors, and strong heating vents or fans. The range should be located for convenient use in the kitchen. Recessed installations must provide complete enclosure of the sides and rear of the range. All openings in the wall or floor where the range is to be installed must be sealed.

Do not pinch the power cord between the range and the wall when you push the range into its mounting location.

The shaded area shown in the illustration is the recommended area for a 120-VAC outlet on the rear wall and area for a through-the-wall connection for gas pipe and shutoff valve.

A grounded electrical outlet is required for this range.

FIGURE 1
Dimensions For Installing The Slide-In Electric Range

FREESTANDING GAS RANGES

Refer to Figure 2 while you read the following installation information.

Proper installation is your responsibility. A qualified technician must install this range. Make sure you have everything necessary for correct installation. It is the responsibility of the installer to comply with the installation clearances specified on the serial/rating plate. This plate is located behind the oven door at the top of the left front frame. **IMPORTANT:** Be sure to observe all governing codes and ordinances.

Clearance Note: A clearance of 30" (76.2 cm) minimum is required when the bottom of a wood or metal cabinet is protected by not less than 1/4" of flame-retardant millboard covered with not less

than #28 MSG sheet steel, 0.015" stainless steel, 0.024" aluminum, or 0.020" copper. A minimum clearance of 36" (91.4 cm) between the top of the cooking platform and the bottom of an unprotected wood or metal cabinet is required.

The cutout shown is for a 25" (63.5 cm) countertop with a 24" (61 cm) base cabinet and no backsplash. The maximum depth for overhead cabinets is 13" (33 cm). For the minimum vertical clearance between the cooking surface and the overhead cabinets, see the previous "Clearance Note." Overhead cabinets installed at either side of the range must be a minimum of 18" (45.7 cm) above the cooking surface. The minimum horizontal distance between the overhead cabinets is 30" (76.2 cm).

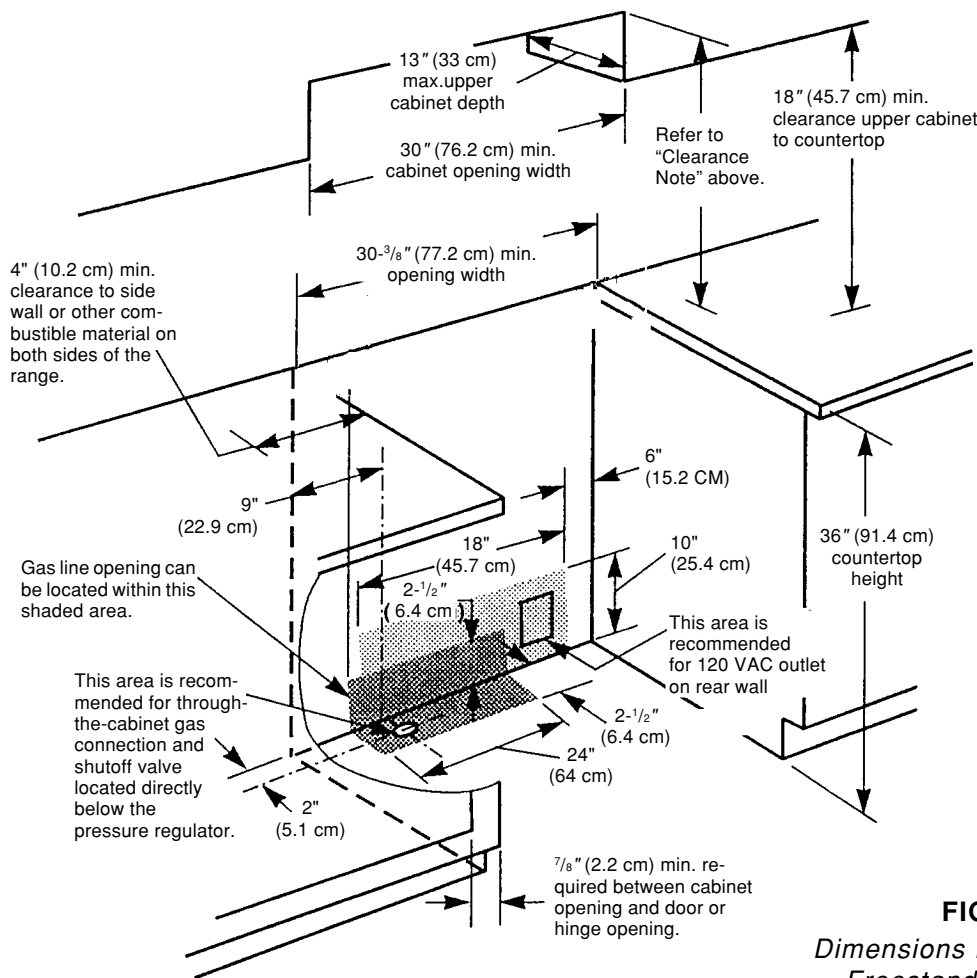

The Anti-Tip bracket MUST be installed.

The range should be located away from strong draft areas, such as windows, doors, and strong heating vents or fans. The range should be located for convenient use in the kitchen. Recessed installations must provide complete enclosure of the sides and rear of the range. All openings in the wall or floor where the range is to be installed must be sealed.

Do not pinch the power cord between the range and the wall when you push the range into its mounting location.

The shaded area shown in the illustration is the recommended area for a 120-VAC outlet on the rear wall and area for a through-the-wall connection for gas pipe and shutoff valve.

A grounded electrical outlet is required for this range.

FIGURE 2

Dimensions For Installing The Freestanding Gas Range

Electronic Range Controls

- **Used on Gas & Electric Models.**
 - Slide-In: Up front glass “Capacitive Touch” switch membrane.
 - Freestanding: Up front glass “Capacitive Touch” membrane.
- **Unique Functions:**
 - **Sabbath Mode:** Allows the oven to be operated continuously during the Jewish Sabbath.
 - **Easy Convection:** Automatically converts standard cooking times and temperatures to convection cooking times and temperatures.
 - **Full Meal Convection:** Ten preprogrammed cook cycles and one favorite cooking cycle.
- **2nd through 5th year parts only warranty on the control.**

Slide-In

- | | |
|---------------------------|----------------------|
| • Electric Models: | • Gas Models: |
| – KESS300B | – KGST300B |
| – KESC300B | – KGST307B |
| – KESC307B | |
| – KESH307B | |

Freestanding

- | | |
|--|----------------------|
| • Electric Models
(Available in late 1995): | • Gas Models: |
| – KERS500B | – KGRT500B |
| – KERC500B | – KGRT507B |
| – KERC507B | |
| – KERH507B | |

Electronic Range Controls

Slide-In

Keypad Layout Convection Slide-In

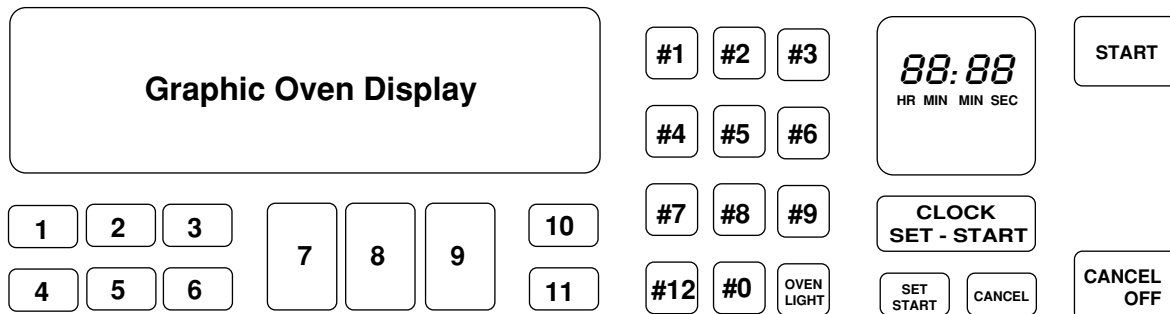

Keypad Layout Non-Convection Slide-In

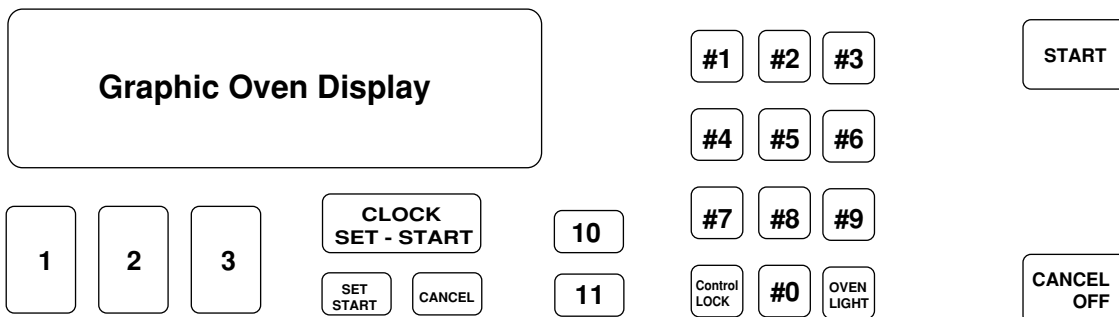

Keypads:

- 1 = Bake
- 2 = Broil
- 3 = Clean
- 4 = Convection Bake
- 5 = Convection Broil
- 6 = Convection Roast
- 7 = Easy Convection (Baked Goods)
- 8 = Easy Convection (Meats)
- 9 = Easy Convection (Other Foods)
- 10 = Cook Time
- 11 = Stop Time
- 12 = Convection Full Meal

Electronic Range Controls

Freestanding

Keypad Layout Convection Freestanding

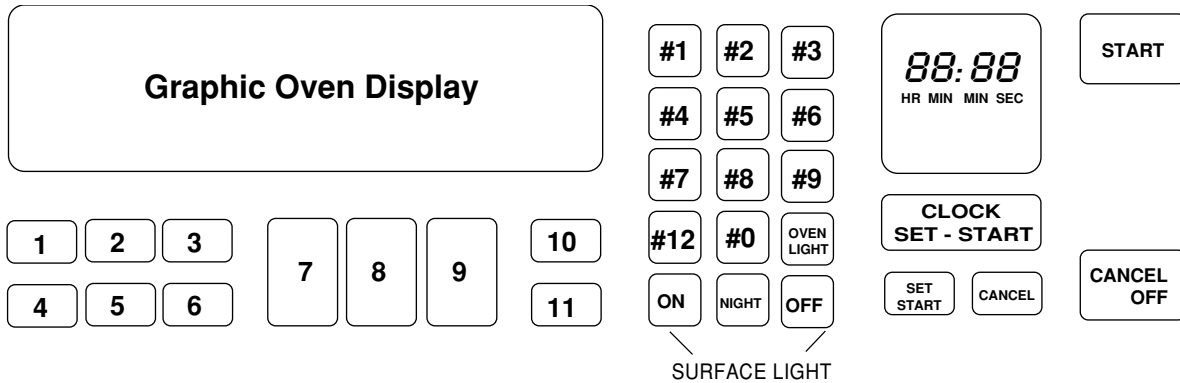

Keypad Layout Non-Convection Freestanding

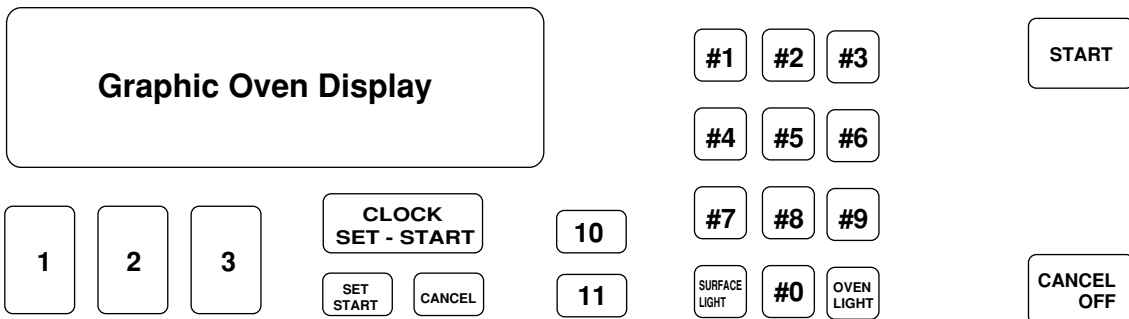

Keypads:

- 1 = Bake
- 2 = Broil
- 3 = Clean
- 4 = Convection Bake
- 5 = Convection Broil
- 6 = Convection Roast
- 7 = Easy Convection (Baked Goods)
- 8 = Easy Convection (Meats)
- 9 = Easy Convection (Other Foods)
- 10 = Cook Time
- 11 = Stop Time
- 12 = Convection Full Meal

Electronic Range Controls

The Graphic Display

NOTE: Ring element used on electric models only.

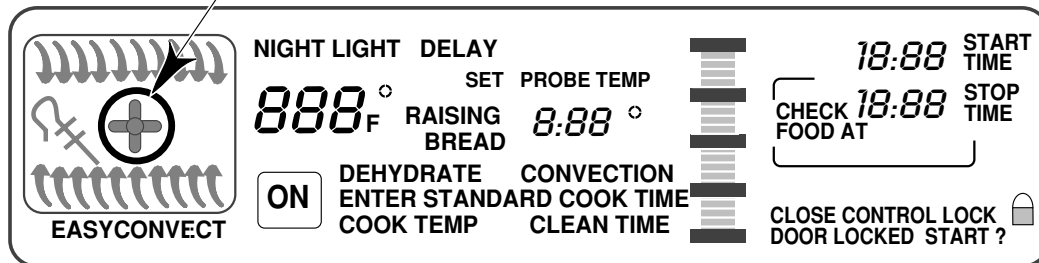

CONVECTION MODELS

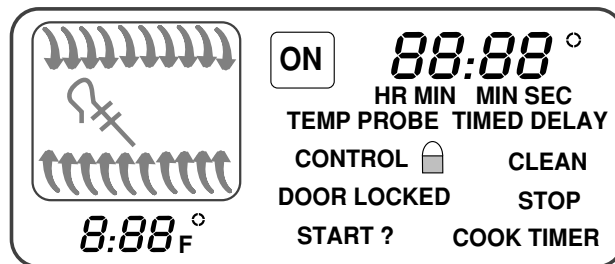

NONCONVECTION MODELS

Electronic Range Controls

Reading The Graphic Display

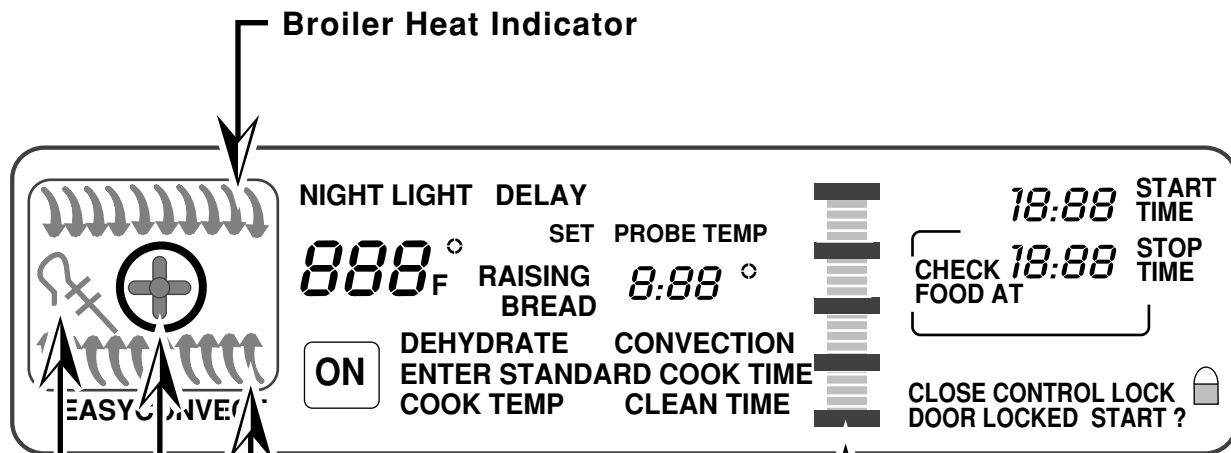

Time Savings Bar Indicates:

% Of Time Remaining In Cook Cycle

OR

% Of Time Saved With EasyConvect

Electronic Range Controls

Easy Convect™

- Available on convection models only.
- Allows the consumer to cook standard oven recipes in the convection mode.
- Three Easy Convect cooking functions:
 - Baked Goods: Converts temperature by -50°F .
 - Meats: Converts time by -20% and temperature by -25°F .
 - Other: Converts time by -10% and temperature by -25°F .

Easy Convect (Meats)

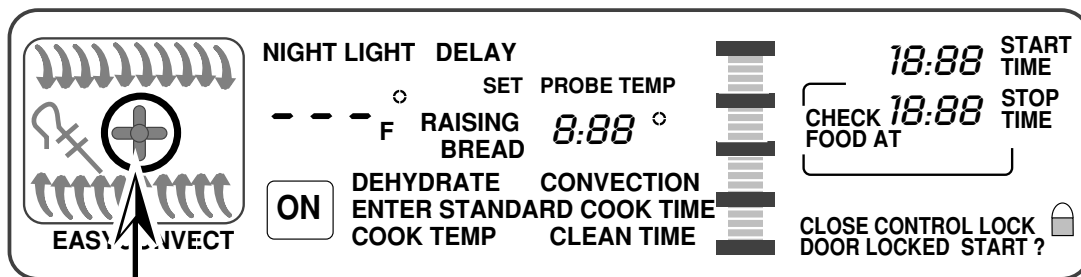

CONVECTION MODELS

NOTE: Ring element used on electric models only.

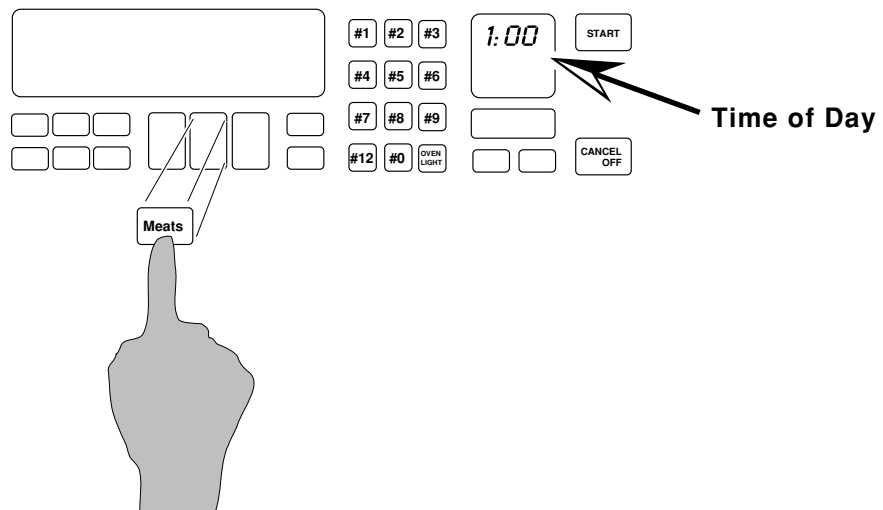

Press the "Meats" keypad.

Electronic Range Controls

Easy Convect (Meats)

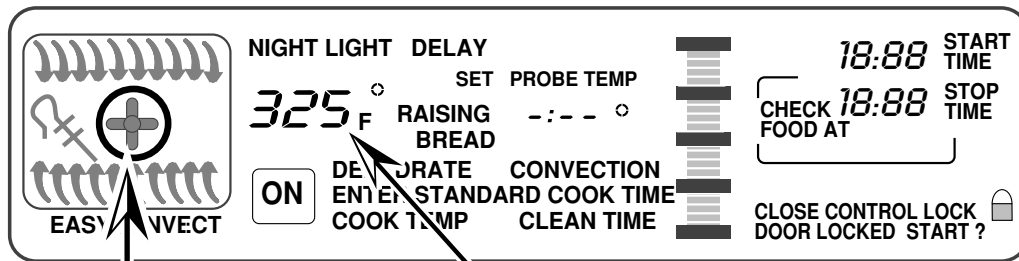

NOTE:
Ring element used
on electric models
only.

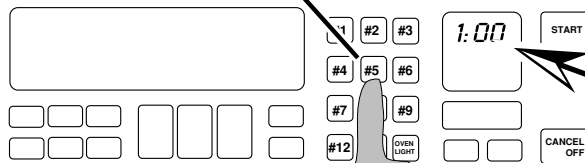

Time of Day

CONVECTION MODELS

Enter the normal cooking temperature.

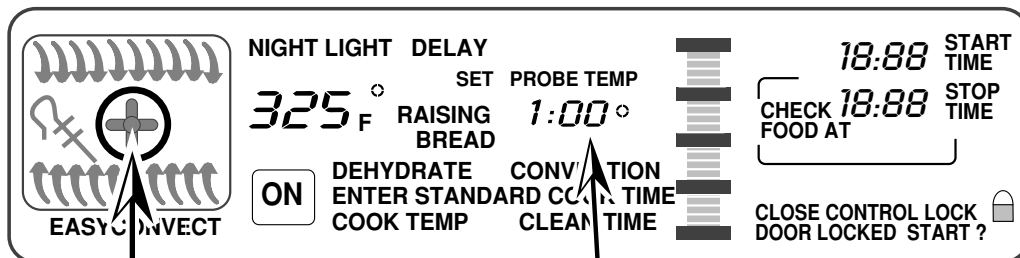

NOTE:
Ring element used
on electric models
only.

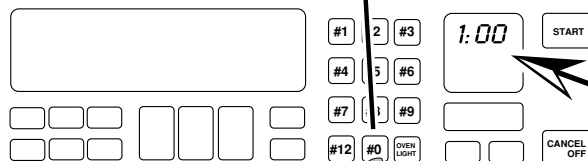

Time of Day

CONVECTION MODELS

Enter the normal cooking time.

Electronic Range Controls

Easy Convect (Meats)

Temperature adjusted by 25°

Convection Cooking Time adjusted by 20%

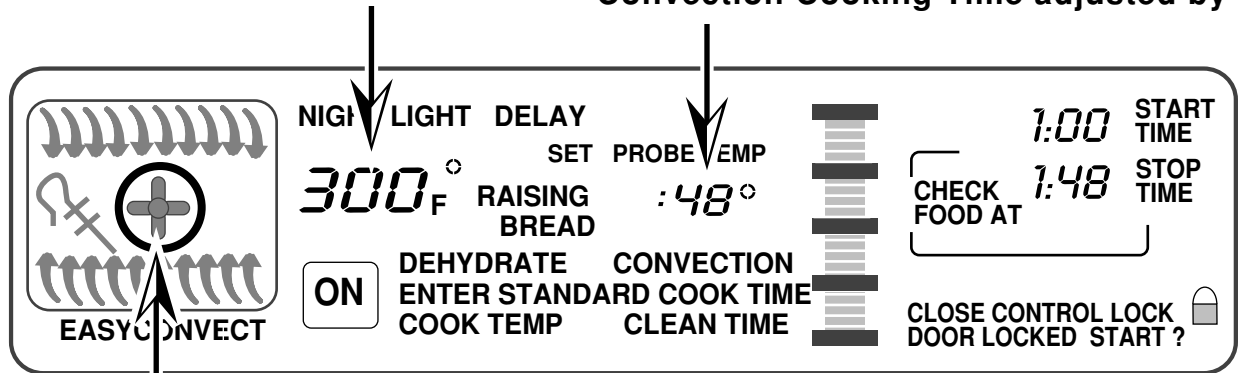

NOTE:
Ring element used
on electric models
only.

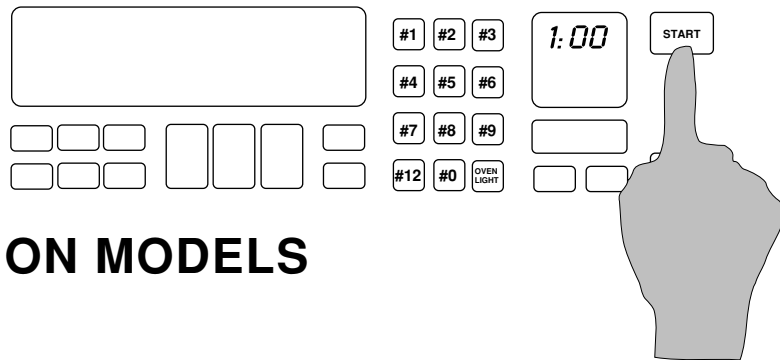

CONVECTION MODELS

Press "Start"

After the Start button is pressed, the control adjusts the convection cooking time by 20% and the temperature by 25-degrees.

Electronic Range Controls

Sabbath Mode

- **Allows the consumer to meet the “No Work” requirements of the Jewish Sabbath. This means that:**
 - The range will operate nonstop as long as power is applied to the range bypassing the 12-hour shutdown default.
 - The range will resume cooking if there is a power failure while in this mode of operation (convection models will resume the “Favorite Cycle”).
- **No tones will sound when in this mode.**
- **Touchpad responses are delayed by 1-second to prevent accidentally turning the range off.**

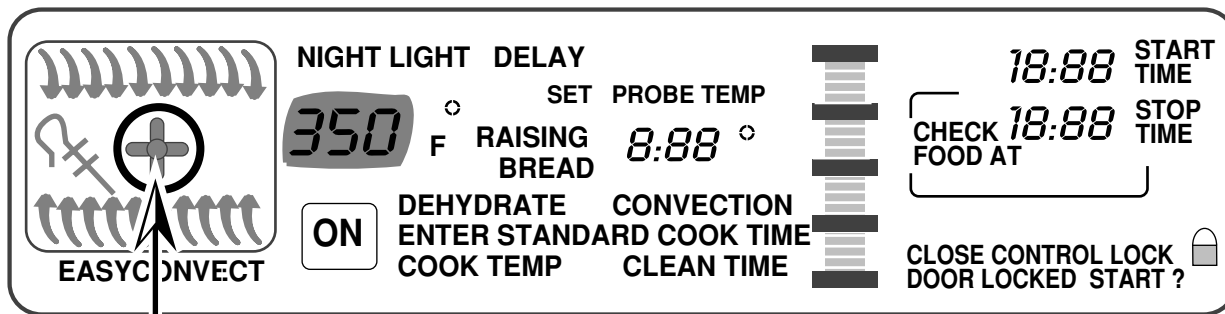

NOTE: Ring element used on electric models only.

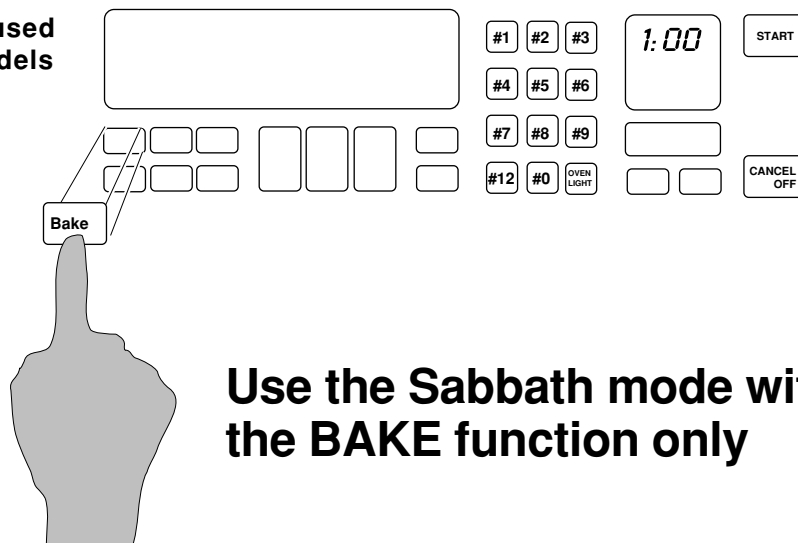

Use the Sabbath mode with the BAKE function only

Electronic Range Controls

Sabbath Mode

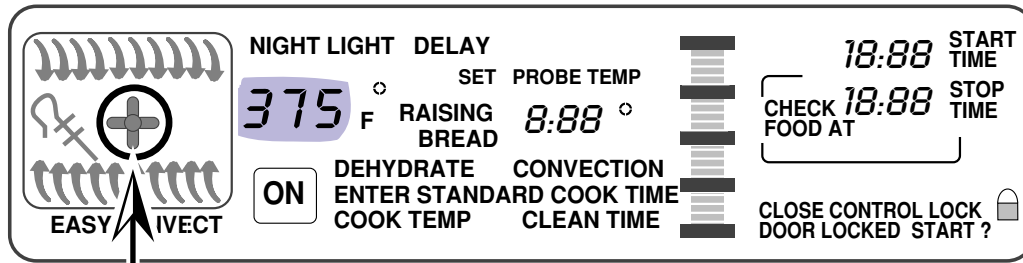

NOTE: Ring element used on electric models only.

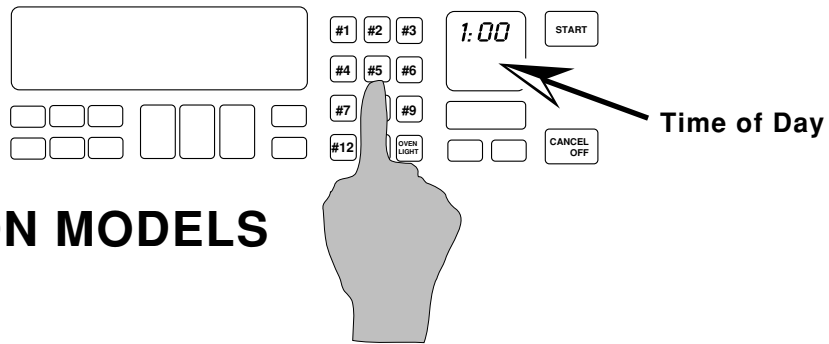

CONVECTION MODELS

Set the temperature you desire to use during the Sabbath Mode. We will use 375°.

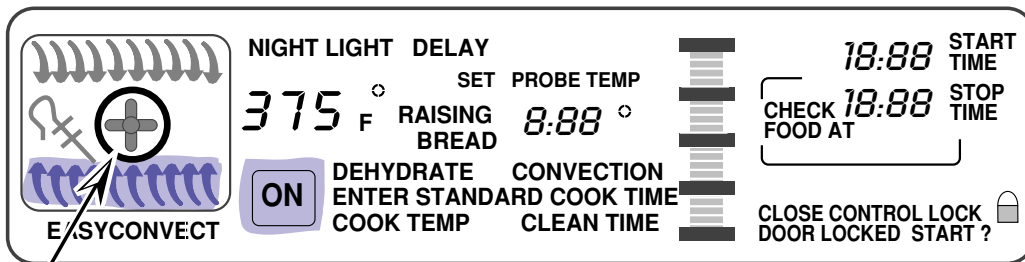

NOTE: Ring element used on electric models only.

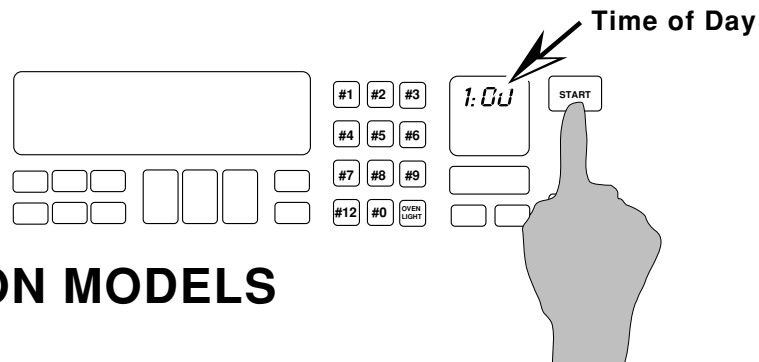

CONVECTION MODELS

Select "Start" and the oven will preheat.

Electronic Range Controls

Sabbath Mode

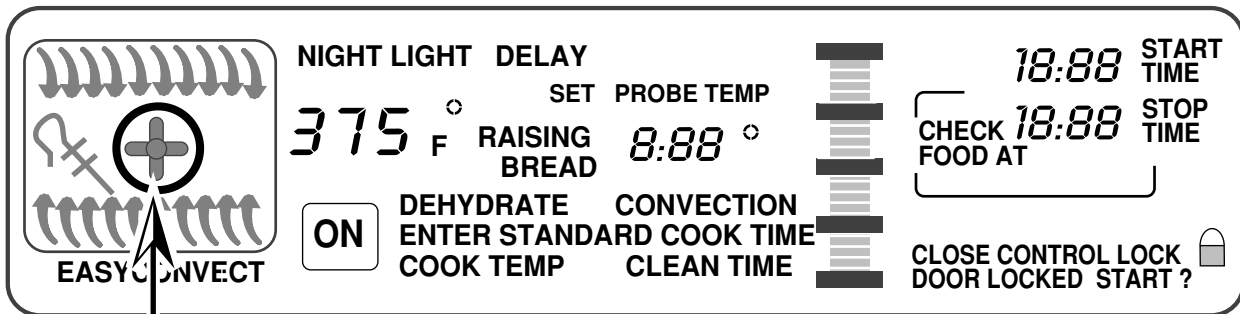

CONVECTION MODELS

NOTE: Ring element used on electric models only.

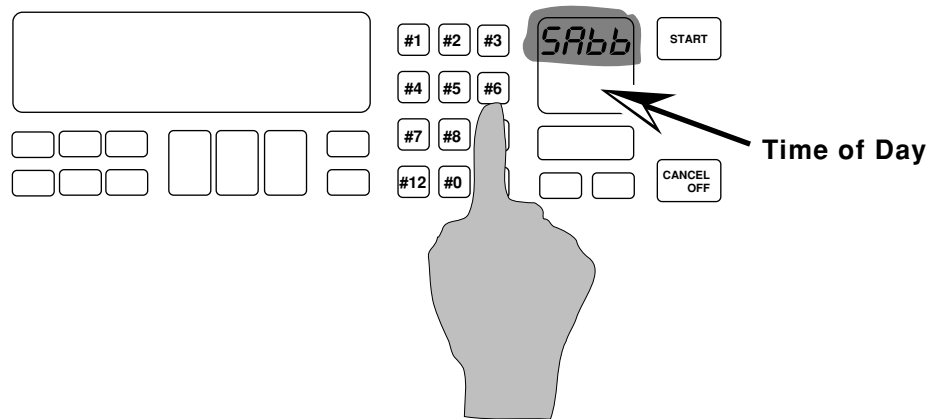

- When the oven has finished preheating, press and hold the #6 keypad for 5-seconds.
- The Time of Day display changes to “SAbb.”
- The Sabbath Mode can only be cancelled by pressing and holding the #6 keypad.

Electronic Range Controls

Clean Mode

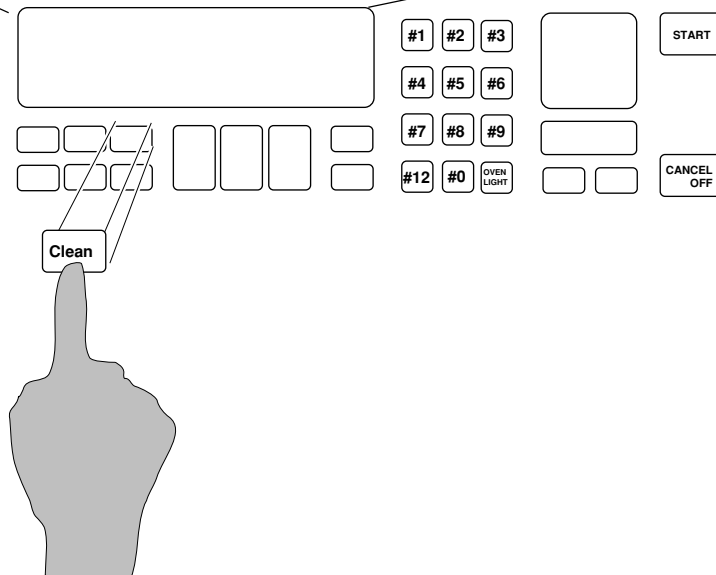
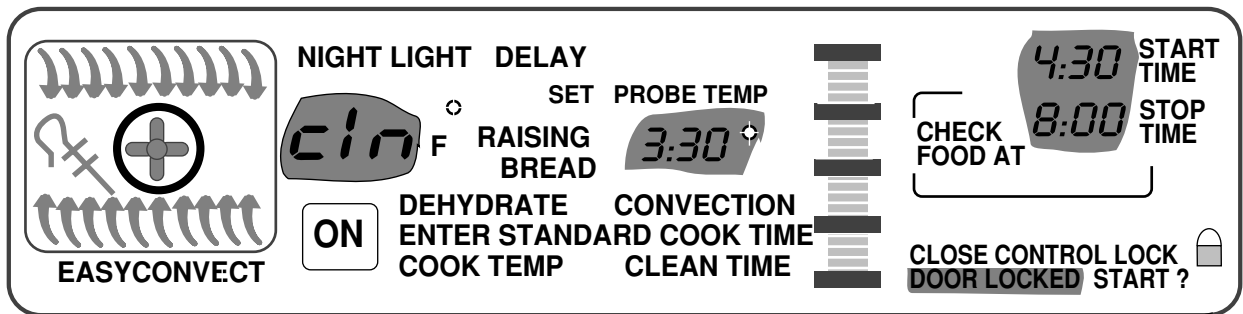

The customer selects the “Clean Mode” on the touch panel. The 3-¹/₂ hour default clean time will be displayed (the customer can select a clean cycle of between 2-¹/₂ and 4-¹/₂ hours). The Start and Stop times will be displayed (based on the time selected by the customer).

Electronic Range Controls

Clean Mode

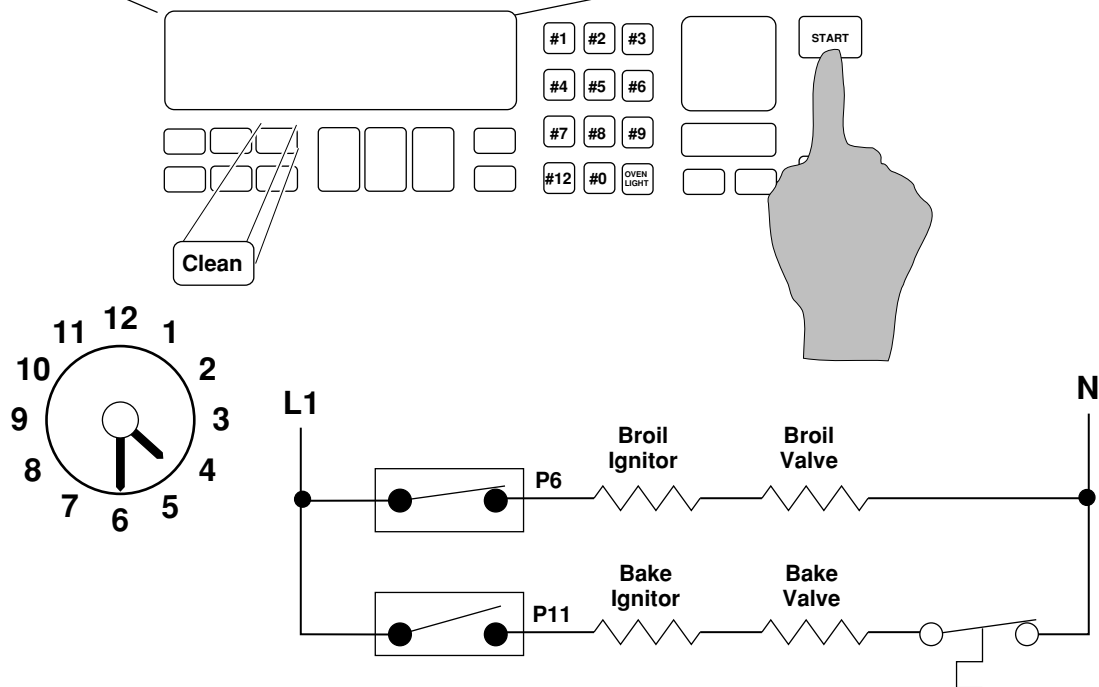
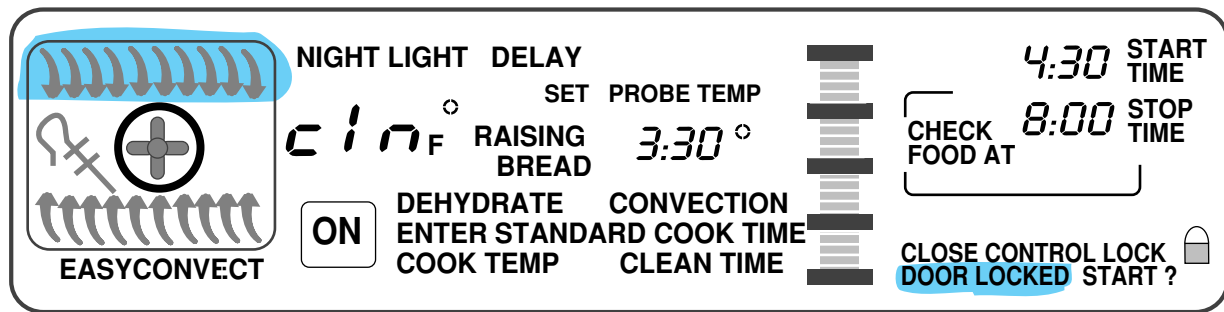

At the instant of start:

- The door will lock.
- The Broil Ignitor is ON.
- The Broil Valve is ON.
- The oven will start heating.

Electronic Range Controls

Clean Mode

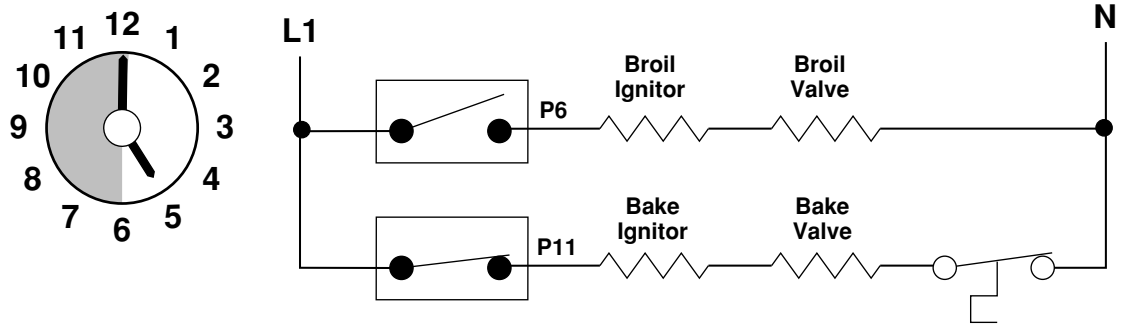
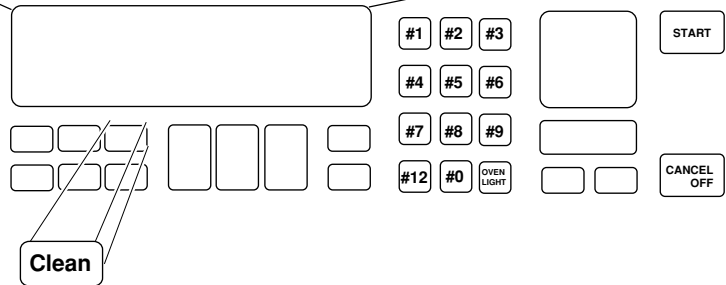
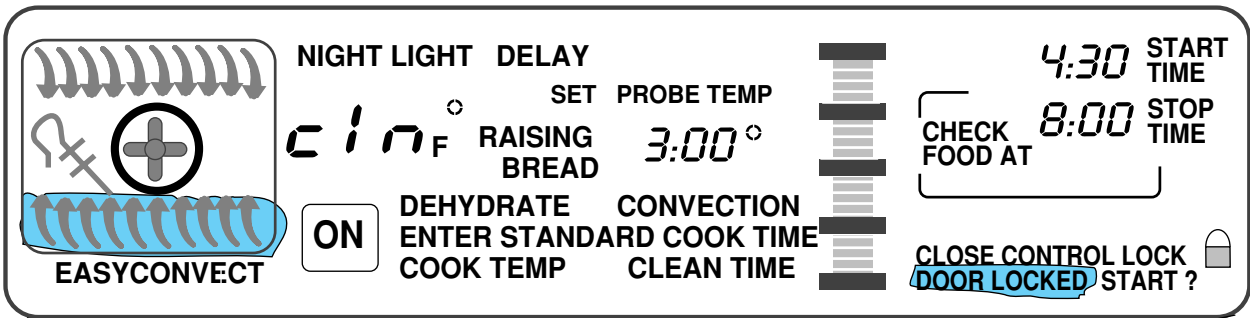

After 30-minutes:

- The Bake Ignitor is ON.
- The Bake Valve is ON.
- The Broil Circuit is OFF.

Electronic Range Controls

Clean Mode

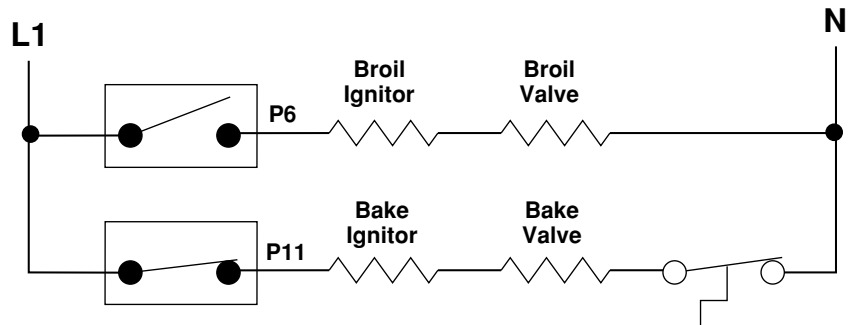
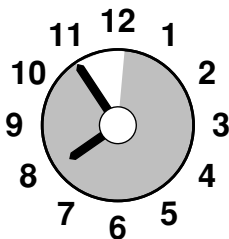
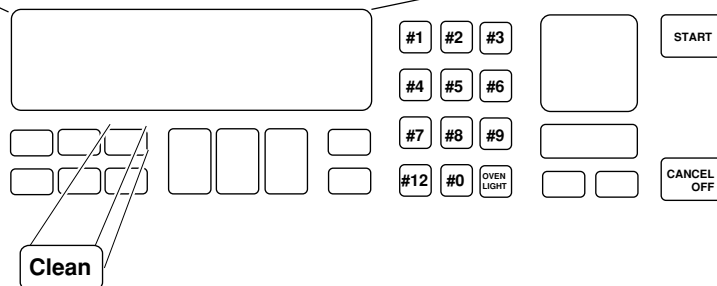
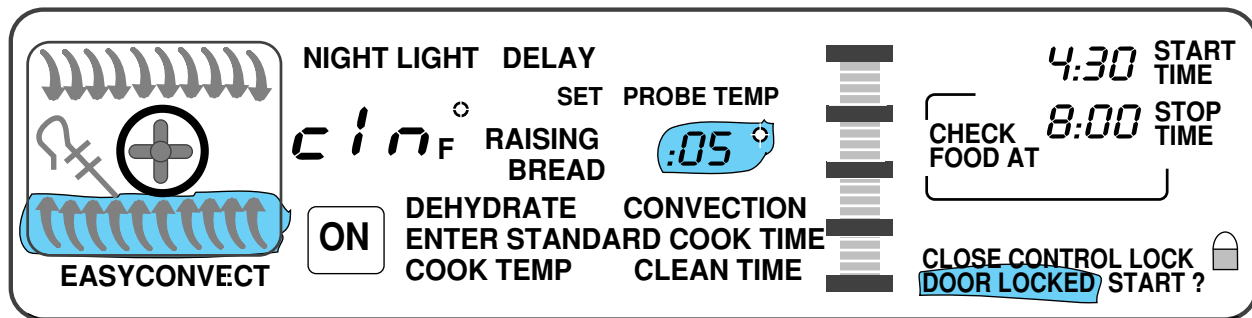

After approximately 3-hours:

- The display shows that the clean time remaining is 5-minutes.

Electronic Range Controls

Clean Mode

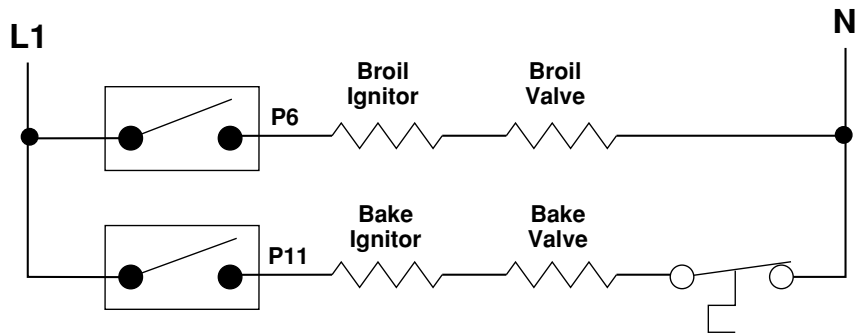
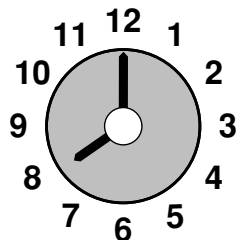
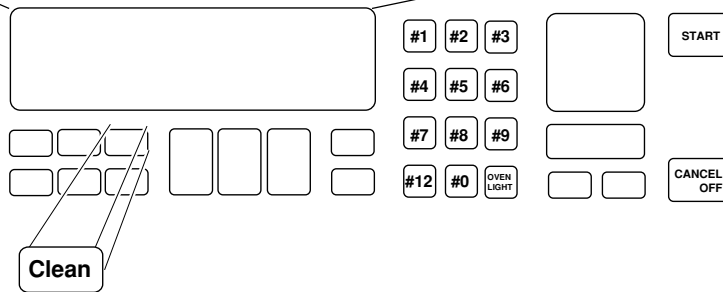
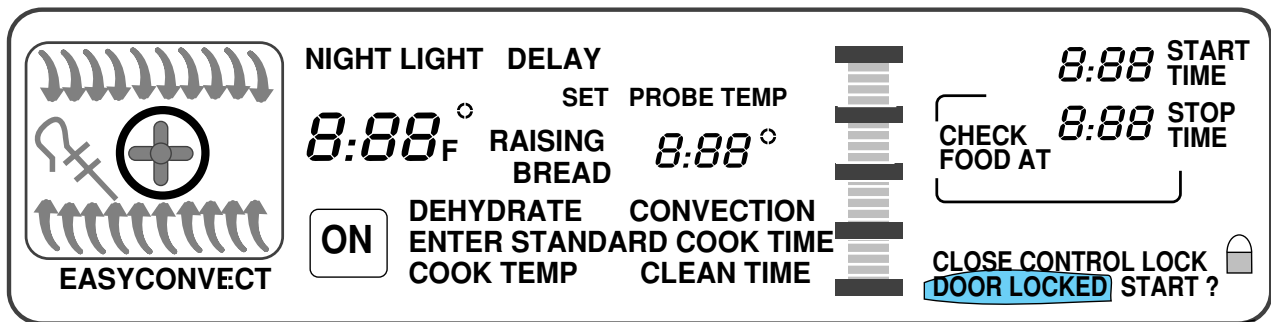

When the Clean Cycle ends:

- The oven door will remain locked.
- The display will show “locked” for as long as the oven is hot.

Electronic Range Controls

Clean Mode

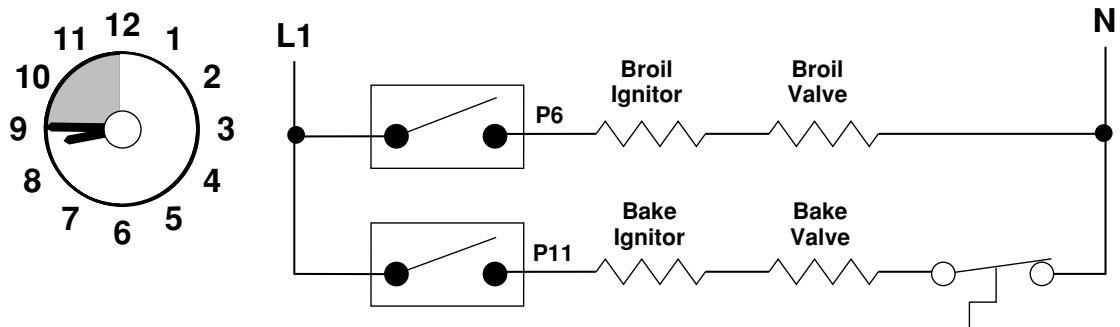
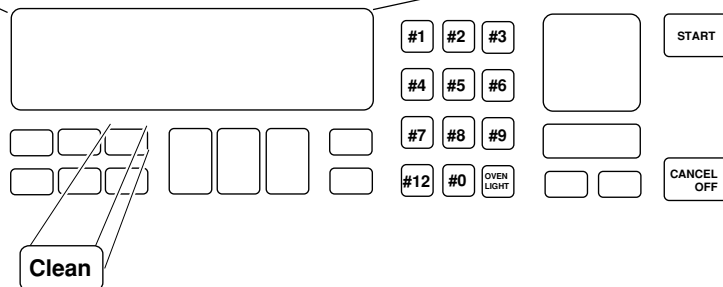
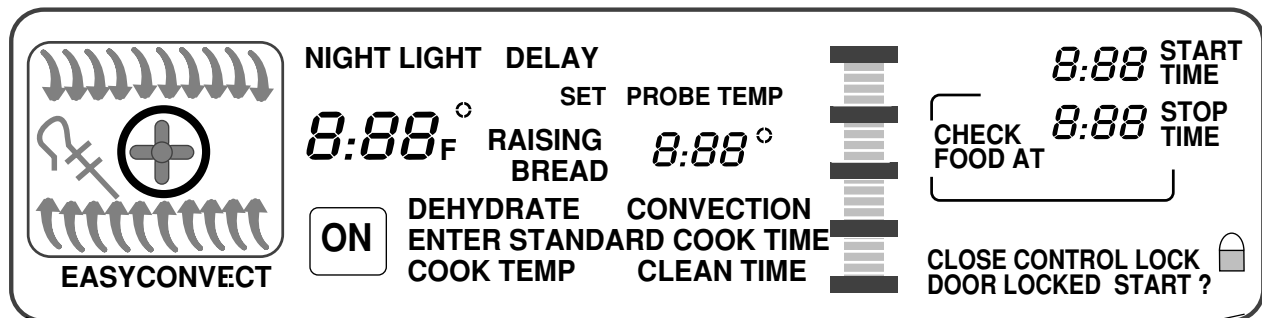

After approximately 45-minutes:

- The oven door will unlock.
- The oven door “locked” display will turn off when the oven temperature is below 600°F.

Things To Know

- Replacement service controls must be programmed to meet the range configuration they are being used in. Failure to do so will result in an F-code (F1 - E3).

Program Procedure

Press the following keypad sequence after the unit has been powered up.

Convection Freestanding/Slide In:

- Convection Broil
- Clean
- Baked Goods
- Stop Time
- #1, #9, #0
- Timer Set
- Start
- Cancel

Non-Convection Freestanding/Slide In:

- Clean
- Stop Time
- #0
- Oven Light
- #1
- Start
- Cancel

This will set the board for the proper range configuration.

NOTE: These program sequences also check all the capacitive glass touchpad keys. If the sequence does not work, unplug the unit, wait 10-seconds, plug the unit back in, and rerun the sequence from the "PF" mode.

Things To Know (Cont'd)

- **On gas models only, the convection fan is delay-started 1-minute for any convection cook cycle.**
 - **On gas models the convection fan cycles on and off during operation.**
 - **On for 10-seconds and off for 20-seconds in convection broil.**
 - **On for 30-seconds and off for 1-seconds in convection bake/roast.**
 - **The convection fan stops running if the oven door is opened.**
 - **The temperature sensor mounting screw is removed from the rear on freestanding models, and from the front on slide-in models.**
 - **The gas shut-off lever is located on the gas safety valve.**
 - **All gas models are shipped with the LP conversions orifice kit Part #9751844 packed with the Use & Care materials. The kit consists of the following:**
 - (2) 6" burner spuds**
 - (2) 8" burner spuds**
 - (1) broiler burner spud**
-
-

Range Cooling System

Refer to Figure 3 while you read this section.

- A cooling fan, in the storage drawer area, is used to maintain optimum temperatures in the console areas.
- Restrictions to the air flow in the cooling systems can cause premature failure of the controls or the thermal protectors.

The cooling fan draws air from inside the base of the cabinet. It forces the air up the air channel, which is located under the left side panel, to the opening at the end of the control panel chassis. Air then flows across the chassis below the control panel, and cools it. Air enters through the series of holes in front of the range top, flows beneath it, and exits to the outside through slots in the rear panel.

The cooling fan is operated by the cooling fan thermal switch, which is located under the right side of the control panel, on the control panel chassis.

When the control panel temperature exceeds 104°F, the thermal switch will close and turn ON the cooling fan.

When the control panel chassis temperature drops below the turn-on point, the thermal switch opens, and turns the cooling fan off.

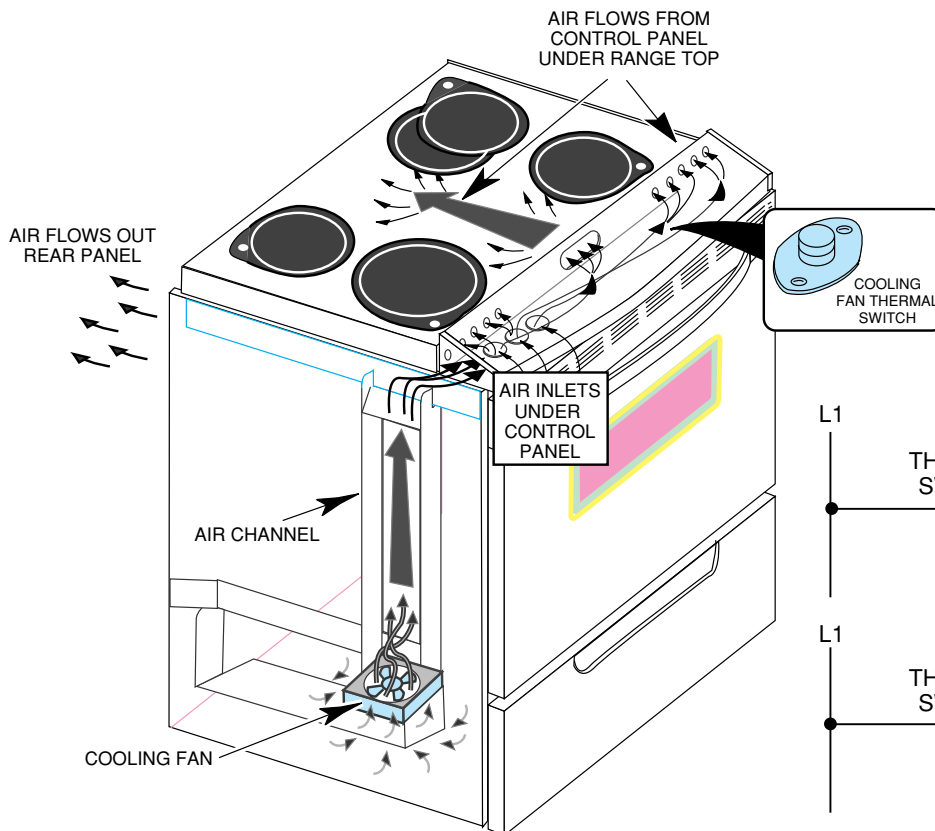
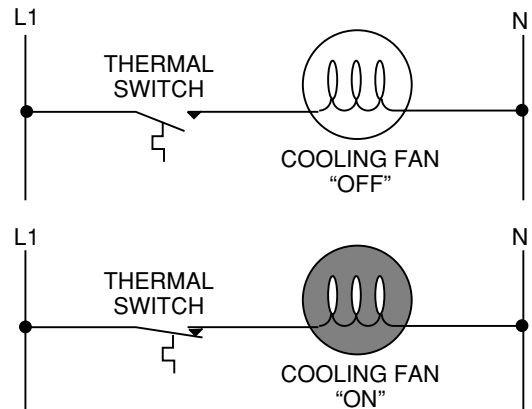

FIGURE 3
The Cooling System



Component Layout

Refer to Figures 4 & 5 for the locations of the individual components in the electric and gas ranges.

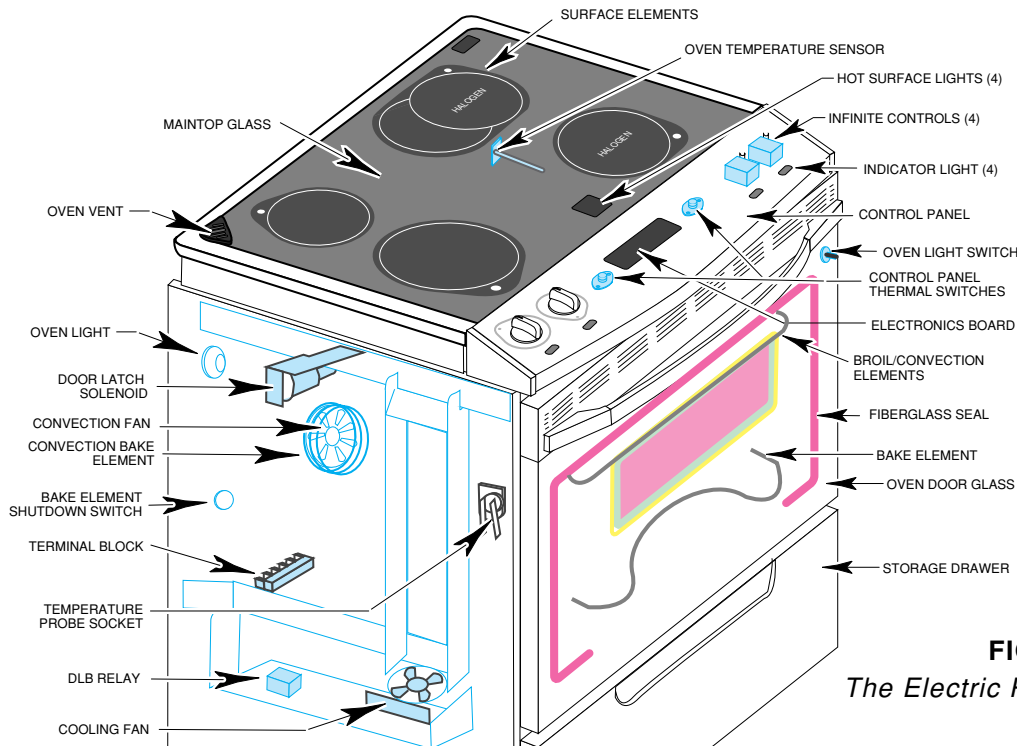

FIGURE 4
The Electric Range Components

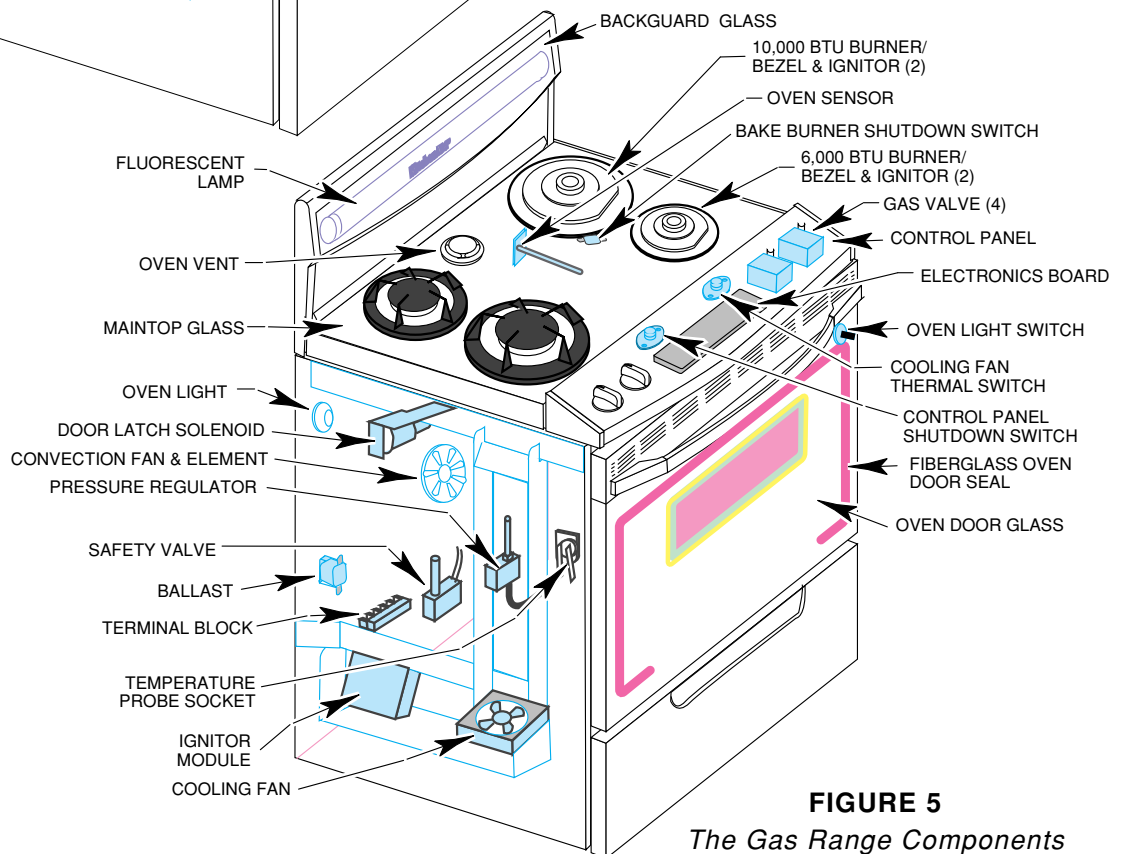

FIGURE 5
The Gas Range Components

Accessing Components Behind The Control Panel

The following major components are serviced by removing the control panel:

- Computer Board
- Capacitive Glass Panel
- Cooling Fan Thermal Switch
- Burner Valves & Switches
- Hi Limit Thermal Switch

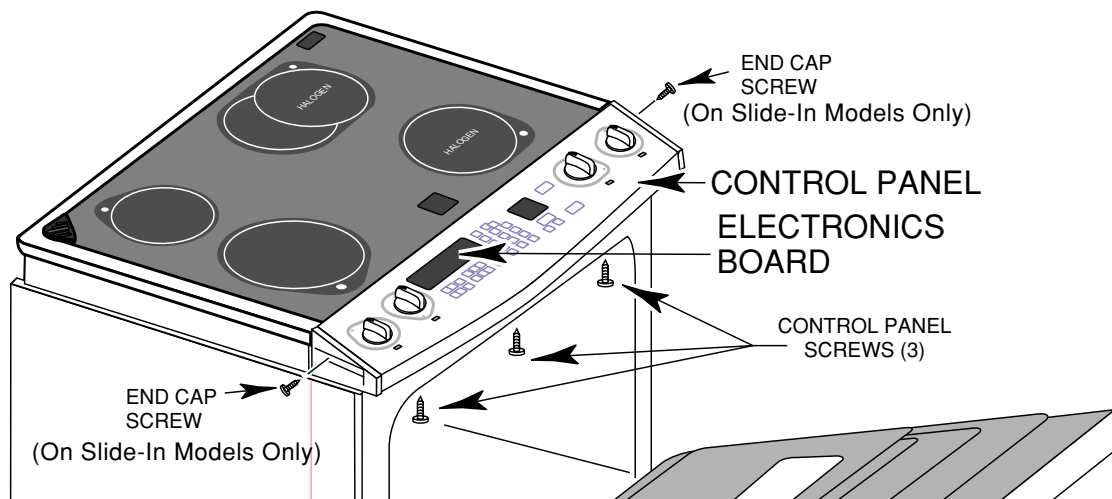

FIGURE 6

Removing The Electric Range Control Panel

Refer to Figure 6 for the following steps.

1. Unplug the power cord plug from the AC receptacle.
2. Open the oven door, and remove the three screws from under the control panel and the two from the end caps, then close the oven door.
3. On gas models, remove the four (4) burner valve stem nuts.
4. Lift the control panel and set it on the maintop so that you can access the components.

Accessing Components Under The Cooktop

The following major components are serviced by raising the cooktop:

- Surface Burner Assemblies
- Ignitors
- Ceran Element Assemblies

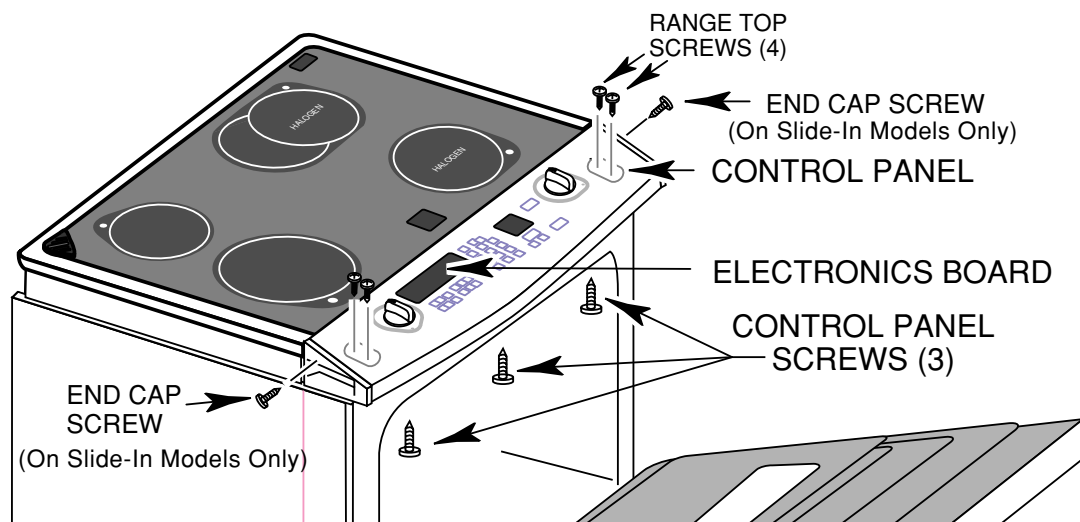

FIGURE 7

Accessing Components Under The Cooktop

Refer to Figure 7 for the following steps.

1. Unplug the power cord plug from the AC receptacle, and if necessary, move the range out from the wall.
2. Open the oven door, and remove the three screws from under the control panel, and the two from the end caps, then close the oven door.
3. Set the control panel on the maintop, and remove the four chassis screws (two on each side) that are under the control panel, then position the control panel back in its normal location.
4. Lift the front of the maintop and prop it up so you can easily access the components underneath. Be careful not to stress any of the wiring when you lift the top.

Accessing Components Behind The Rear Panel

The following major components are serviced by removing the component and access covers:

- Locking Solenoid
- Convection Fan Motor
- Temperature Sensor (Freestanding Models Only)

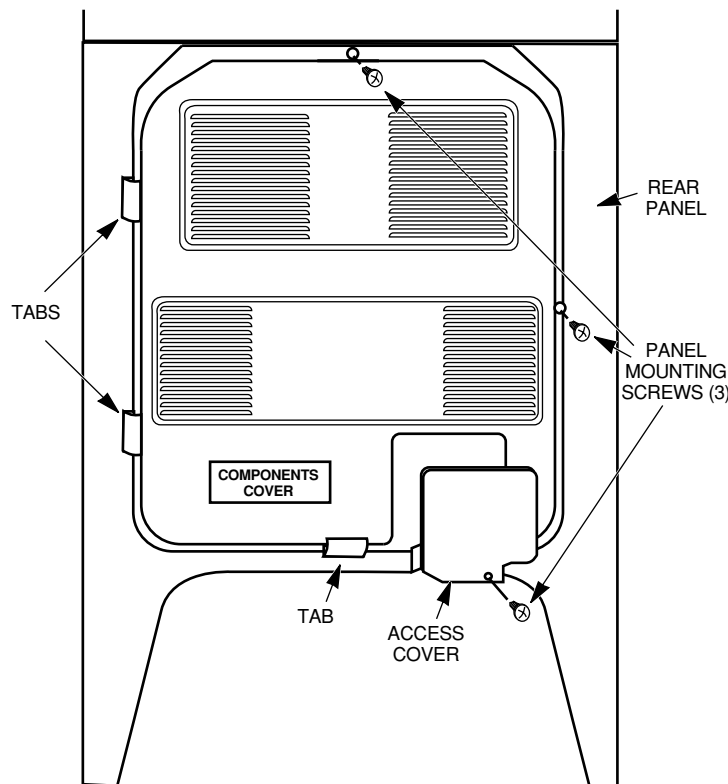

FIGURE 8

*Accessing Components Behind
The Rear Panel*

Refer to Figure 8 for the following steps.

1. Disconnect the power cord plug from the AC receptacle.
2. Pull the range out from the wall or cabinet cutout far enough to access the back panel.
3. Remove the three screws from the component and access covers that are mounted to the rear panel, then unhook and remove the covers.

Accessing Components Behind The Storage Drawer

The following major components are serviced by removing the storage drawer:

- Cooling Fan
- Burner Valve & Pressure Regulator
- Ignitor Module
- Double Line Break (DLB) Relay (Electric Only)

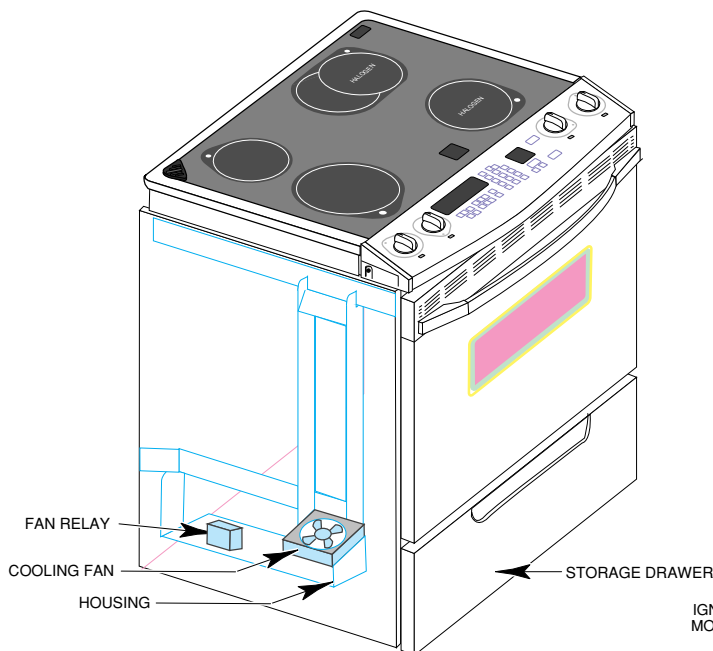

FIGURE 9
*Removing The Storage Drawer
Electric Models*

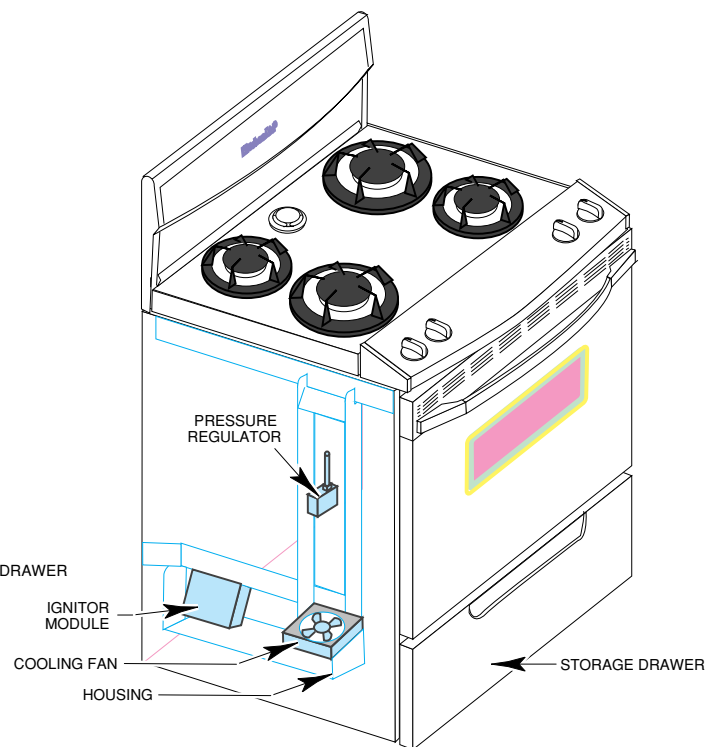

FIGURE 10
*Removing The Storage Drawer
Gas Models*

Refer to Figures 9 or 10 for the following steps.

1. Unplug the range's power cord plug from the AC receptacle.
2. Remove the storage drawer from the range.
3. From inside the storage area, remove the three mounting screws from the housing.
4. Remove the housing by sliding it forward and unhooking the tab from the slot in the bottom of the range.

Error Codes

The microcomputer contains self-diagnostic codes that will be displayed on the control panel whenever a failure occurs when using the range. Audible 1-second and 5-second tones will sound to alert the user whenever a failure code is being displayed. Each code can be cancelled by pressing the CANCEL/OFF keypad. The code will return if the user attempts to use the range before the failure has been corrected.

The F/E-Codes will be displayed for the indicated reasons, shown in the following chart.

FAULT	ERROR	FAULT PRIORITY	FAULT CONSTANT NAME IN SOFTWARE	FAULT DESCRIPTION	SERVICE ACTION
F1	E0	N/A	FAULT EEPROM	EEPROM READ FAULT (SILENT FAULT, NOT DISPLAYED)	SUSPECT CONTROL
F1	E1	N/A	EEPROM CHECKSUM ERROR	EEPROM CHECKSUM DOES NOT MATCH AT START KEY (SILENT FAULT, NOT DISPLAYED)	SUSPECT CONTROL
F1	E3	7	CONFIG JUMPERS NO MATCH	CONFIGURATION JUMPER CHANGE, FREESTAND, ELECTRIC SWITCHES ,OR P9 (PIN 6 TO 7) CHANGED SINCE POWER UP	SUSPECT CONTROL
F1	E4	2	Q8 SHORTED	Q8 SHORTED	SUSPECT CONTROL
F1	E9	0	STACK OVERFLOW	STACK OVERFLOW, HIGHEST PRIORITY	SUSPECT CONTROL
F2	E0	4	CANCEL KEY TOO LOW	CANCEL KEY LEVEL TOO LOW (OPEN)	SUSPECT KEYPAD ASSEMBLY
F2	E2	3	CANCEL KEY CHANNEL	CANCEL KEY LOOP TEST FAILED	SUSPECT KEYPAD ASSEMBLY
F2	E3	5	KEY DOWN TOO LONG	KEY HELD DOWN TOO LONG OR KEYBOARD SHORT	SUSPECT KEYPAD ASSEMBLY
F2	E4	6	KEYS UNSETTLED	KEYS UNSETTLED PROBABLY DUE TO NOISE	SUSPECT KEYPAD ASSEMBLY
F3	E0	9	OPEN PLAT	PLAT SENSOR OPEN	SUSPECT KEYPAD ASSEMBLY
F3	E1	8	SHORTED PLAT	PLAT SENSOR SHORTED	SUSPECT TEMP SENSOR
F3	E2	10	OVEN TEMP TOO HIGH	OVEN TEMP TOO HIGH (RUNAWAY)	SUSPECT TEMP SENSOR
F4	E1	15	SHORTED MEAT PROBE	HEAT PROBE SHORTED (LESS THAN 1500 OHMS)	SUSPECT TEMP SENSOR
F5	E1	13	SELF-CLEAN LATCH WILL NOT MAKE	SELF-CLEAN LATCH WILL NOT MAKE AFTER 30-SECONDS	SUSPECT MEAT PROBE
F5	E3	1	LOSS OF GND L1 N REVERSE	LOSS OF 120 VAC ACROSS L1 TO GROUND, OR Q19 CIRCUIT ERROR	SUSPECT INPUT SWITCH
F5	E5	14	SELF CLEAN TEMP NOT SATISFIED	SELF-CLEAN TEMPERATURE NOT SATISFIED AFTER 30-MINUTES	SUSPECT INPUT SWITCH
F5	E6	16	DOOR OPEN AND LOCKED	DOOR LOCKED WITH DOOR OPEN	SUSPECT INPUT SWITCH
F5	E7	17	DOOR WILL NOT UNLATCH	DOOR UNLOCKED AND WILL NOT UNLATCH	SUSPECT INPUT SWITCH
F6	E0	12	AMBIENT OVER TEMP	AMBIENT SENSOR OPENED (TOO HOT)	F6
F7	E0	11	INPUT SWITCH ERROR	INPUT SWITCHES WILL NOT FOLLOW THEIR STROBE LEVEL (SHORTED TO GROUND)	F7
PF				POWER FAILURE (NOT A FAILURE OF CONTROL. PRESS CANCEL)	

Hidden Functions

The displays shown in the chart are codes that are programmed into the range that are not normally displayed. To use these hidden codes, touch and hold the indicated keypad for 5-seconds. The display's code is described in the following chart.

KEYPAD	DESCRIPTION OF CODE
Bake	Calibration allows preset bake temperature to be varied +35°F (21°C) to -35°F (-21°C).
Broil	Toggles between F (Fahrenheit) & C (Celsius).
0	Displays the last F/E code that was used & the latest ROM revision.
1	Shows the type of range the control is configured for.
3	Locks out the keypads so they cannot be used.
6	Switches the range to the "Sabbath" mode.
7	Changes the frequency of the tones.
Clock	Turns off the clock (time-of-day) display.
Cook Time	Turns off the "end-of-cycle" tones.
Stop Time	Turns off the keypad entry tones.
Timer Start	Turns off the timer operating tones.
Timer Cancel	Turns on the "sell" mode.
Conv. Bake	Used to dehydrate food.
Baked Goods	Used for raising bread dough.

The Component Test Charts

Test Chart 1

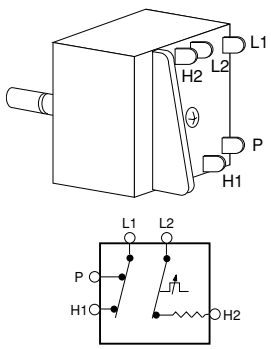
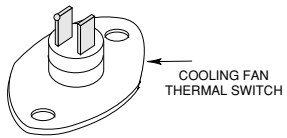
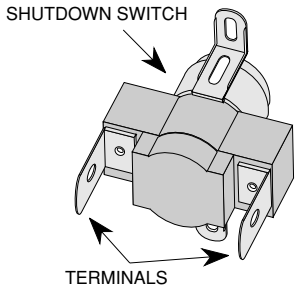
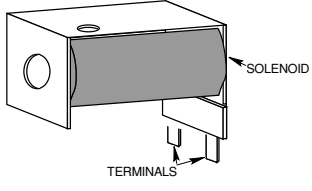
COMPONENT ILLUSTRATION	COMPONENT	TEST PROCEDURE	TEST RESULTS								
	Electronics Board	Test all input and output connections to board.	Refer to the error codes on the previous two pages.								
	Infinite Switches	<p>Set the ohmmeter to R x 1.</p> <p>Connect the meter leads to the switch terminals, and measure the continuity when the switch is turned ON and OFF.</p>	<table border="1"> <thead> <tr> <th>Switch ON</th> <th>Switch OFF</th> </tr> </thead> <tbody> <tr> <td>L1-P = 0 Ω</td> <td>L1-P = ∞ Ω</td> </tr> <tr> <td>L1-H1 = 0 Ω</td> <td>L1-H1 = ∞ Ω</td> </tr> <tr> <td>L2-H2 = 0 Ω</td> <td>L2-H2 = ∞ Ω</td> </tr> </tbody> </table>	Switch ON	Switch OFF	L1-P = 0 Ω	L1-P = ∞ Ω	L1-H1 = 0 Ω	L1-H1 = ∞ Ω	L2-H2 = 0 Ω	L2-H2 = ∞ Ω
Switch ON	Switch OFF										
L1-P = 0 Ω	L1-P = ∞ Ω										
L1-H1 = 0 Ω	L1-H1 = ∞ Ω										
L2-H2 = 0 Ω	L2-H2 = ∞ Ω										
	Cooling Fan Thermostat	<p>Set the ohmmeter to R x 1.</p> <p>Connect the meter leads to the thermostat terminals, and measure the continuity when the switch is heated above 104°F, and then cools to below 104°F.</p>	<p>Above 104°F = 0 Ω.</p> <p>Below 104°F = ∞ Ω.</p>								
	<p>Bake & Broil Element Shutdown Switch</p> <p>OR</p> <p>Bake Burner Shutdown Switch</p>	<p>Set the ohmmeter to R x 1.</p> <p>Connect the meter leads to the thermostat terminals, and measure the continuity when the switch is heated above 395°F, and then cools to below 395°F.</p>	<p>Above 395°F = 0 Ω.</p> <p>Below 395°F = ∞ Ω.</p>								
	Door Latch Solenoid	<p>Set the ohmmeter to R x 10.</p> <p>Connect one of the meter leads to circuit board pin J1-1.</p> <p>Connect the other meter lead to circuit board pin J1-8.</p>	55 Ω. ±10 Ω								

Test Chart 2

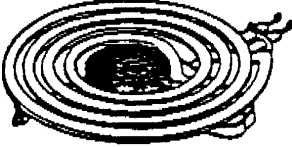
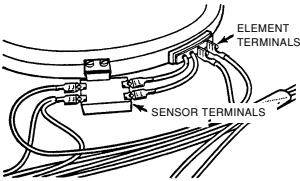
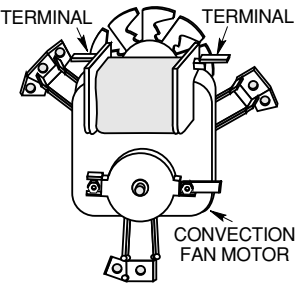
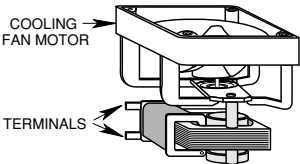
COMPONENT ILLUSTRATION	COMPONENT	TEST PROCEDURE	TEST RESULTS
	Coil Elements	<p>Set the ohmmeter to R x 1.</p> <p>Connect the meter leads to the element terminals, and measure the continuity.</p>	<p>8" Coil (2600W) = 22 Ω ±5 Ω</p> <p>6" Coil (1500W) = 38 Ω ±5 Ω</p>
	Ceran Elements	<p>Set the ohmmeter to R x 1.</p> <p>Connect the meter leads to the element terminals, and measure the continuity. NOTE: Halogen tubes should show continuity.</p>	<p>9" Rad (2400W) = 22 Ω ±5 Ω</p> <p>7" Rad (1700W) = 32 Ω ±5 Ω</p> <p>6" Rad (1400W) = 39 Ω ±5 Ω</p> <p>7" Hal (1800W) = 0 Ω</p> <p>Dual Oval (2500W Tot) Hal Inner (1500W) = 0 Ω Rad Outer (1000W) = 50 ±5 Ω</p>
	Convection Fan Motor	<p>Set the ohmmeter to R x 1.</p> <p>Connect one of the meter leads to circuit board pin J1-1.</p> <p>Connect the other meter lead to circuit board pin J1-6.</p>	15 Ω. ±3 Ω
	Cooling Fan Motor	<p>Set the ohmmeter to R x 10.</p> <p>Connect one of the meter leads to circuit board pin J1-1.</p> <p>Connect the other meter lead to the yellow wire marked "FAN" on the cooling fan thermal switch.</p>	65 Ω. ±10 Ω

Test Chart 3

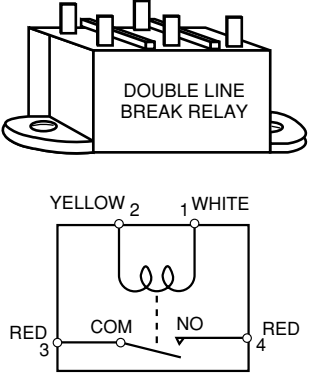
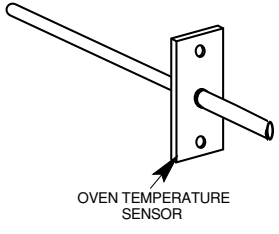
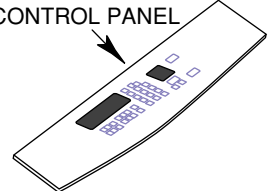
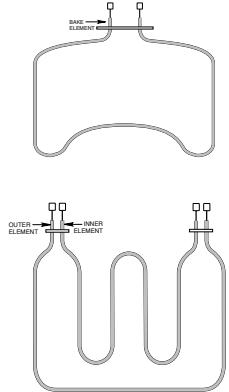
COMPONENT ILLUSTRATION	COMPONENT	TEST PROCEDURE	TEST RESULTS																		
	<p>Double Line Break (DLB) Relay</p>	<p>Set the ohmmeter to R x 1.</p> <p>Connect the meter leads to DLB relay terminals 3 & 4.</p> <p>Apply 120 VAC to terminals 1 & 2 of the DLB relay.</p> <p>Measure the continuity at pins 3 & 4 with and without AC power applied.</p>	<p>120 VAC Applied = 0 Ω.</p> <p>120 VAC Not Applied = ∞ Ω.</p>																		
	<p>Oven Temperature Sensor</p>	<p>Set the ohmmeter to R x 100.</p> <p>Connect one of the meter leads to circuit board pin P1-10.</p> <p>Connect the other meter lead to circuit board pin P1-11.</p>	<table border="1"> <thead> <tr> <th>Temp (°F)</th> <th>Resist (Ω)</th> </tr> </thead> <tbody> <tr> <td>32 ± 1.9</td> <td>1000 ± 4.0</td> </tr> <tr> <td>75 ± 2.5</td> <td>1091 ± 5.3</td> </tr> <tr> <td>250 ± 4.4</td> <td>1453 ± 8.9</td> </tr> <tr> <td>350 ± 5.4</td> <td>1654 ± 10.8</td> </tr> <tr> <td>450 ± 6.9</td> <td>1853 ± 13.5</td> </tr> <tr> <td>550 ± 8.2</td> <td>2047 ± 15.8</td> </tr> <tr> <td>650 ± 8.6</td> <td>2237 ± 18.5</td> </tr> <tr> <td>800 ± 13.6</td> <td>2667 ± 24.4</td> </tr> </tbody> </table>	Temp (°F)	Resist (Ω)	32 ± 1.9	1000 ± 4.0	75 ± 2.5	1091 ± 5.3	250 ± 4.4	1453 ± 8.9	350 ± 5.4	1654 ± 10.8	450 ± 6.9	1853 ± 13.5	550 ± 8.2	2047 ± 15.8	650 ± 8.6	2237 ± 18.5	800 ± 13.6	2667 ± 24.4
Temp (°F)	Resist (Ω)																				
32 ± 1.9	1000 ± 4.0																				
75 ± 2.5	1091 ± 5.3																				
250 ± 4.4	1453 ± 8.9																				
350 ± 5.4	1654 ± 10.8																				
450 ± 6.9	1853 ± 13.5																				
550 ± 8.2	2047 ± 15.8																				
650 ± 8.6	2237 ± 18.5																				
800 ± 13.6	2667 ± 24.4																				
	<p>Capacitive Glass Touch Panel.</p>	<p>Unplug the unit, wait 10-seconds, plug the unit back in, and run the program sequence on page 23 of this Job Aid.</p>	<p>All keypads touched, should show a response.</p>																		
	<p>Bake Element.</p> <p>Broil Element.</p>	<p>Set the ohmmeter to R x 1.</p> <p>Connect the meter leads to the element terminals and measure the resistance.</p>	<p>Bake = 20 ± 5Ω.</p> <p>Broil:</p> <p>Inner = 35 ± 5Ω.</p> <p>Outer = 55 ± 5Ω.</p>																		

Wiring Diagram

Electric Ranges

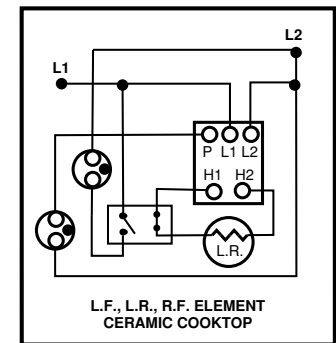
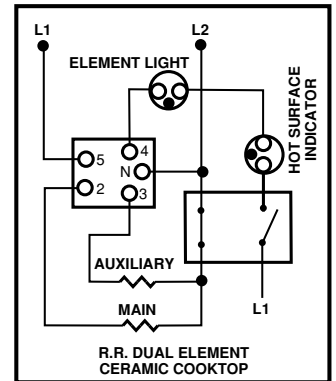
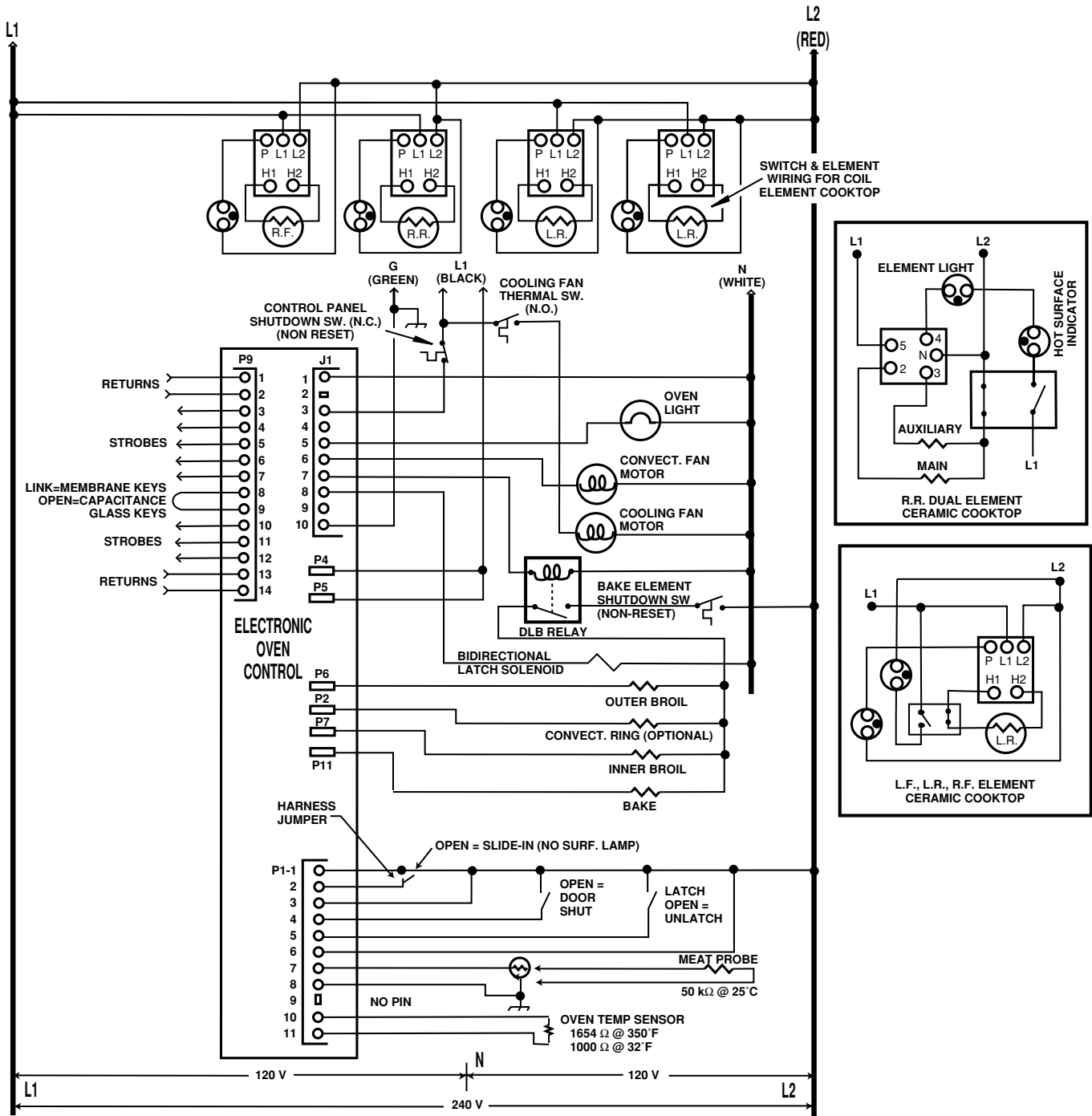

Strip Circuits

Electric Ranges

BAKE (& PREHEAT)

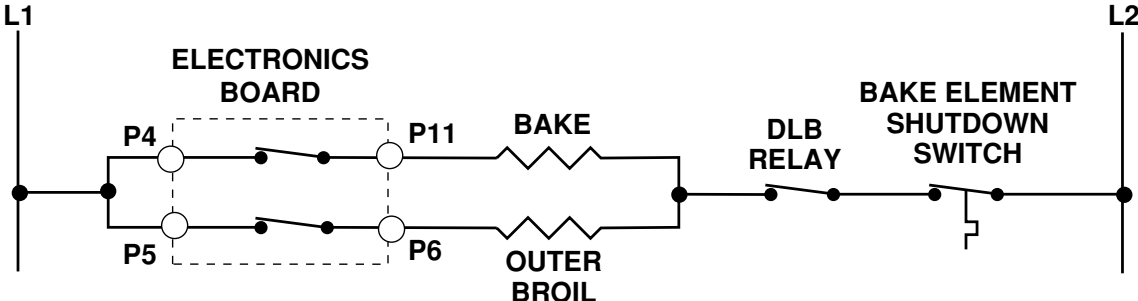

ECONOMY BROIL

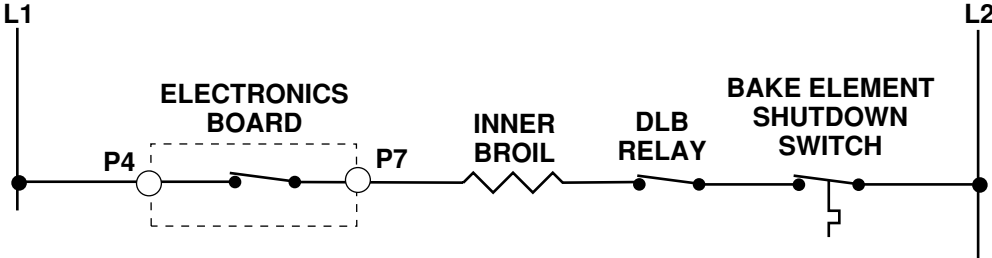

STANDARD BROIL

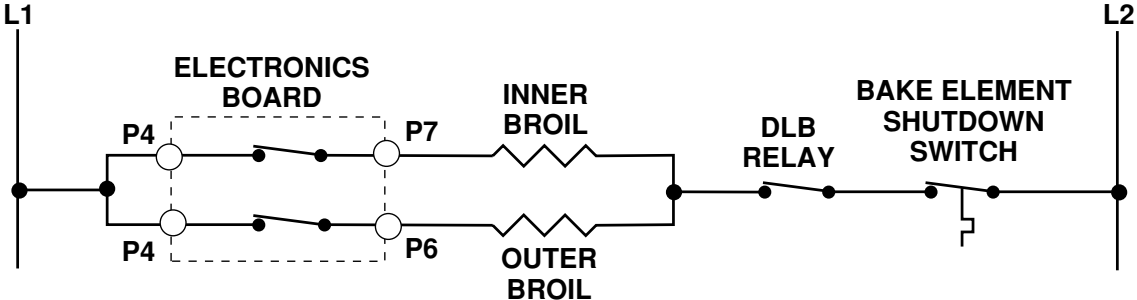

CLEAN

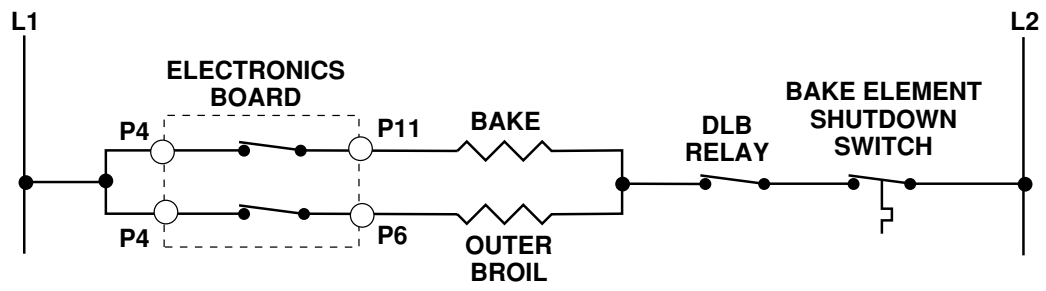

LATCH DRIVING CIRCUIT

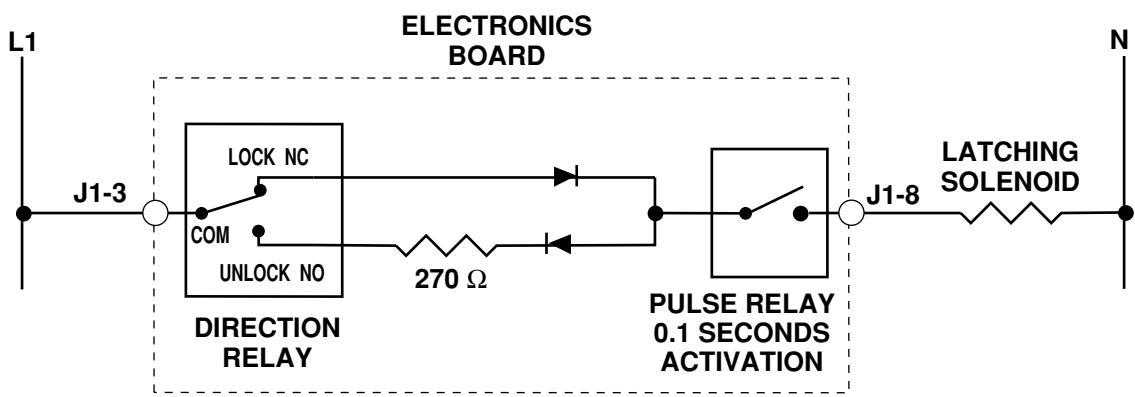

CONVECTION ROAST, PREHEAT FOR CONVECTION BAKE, DEHYDRATE, & RAISING BREAD

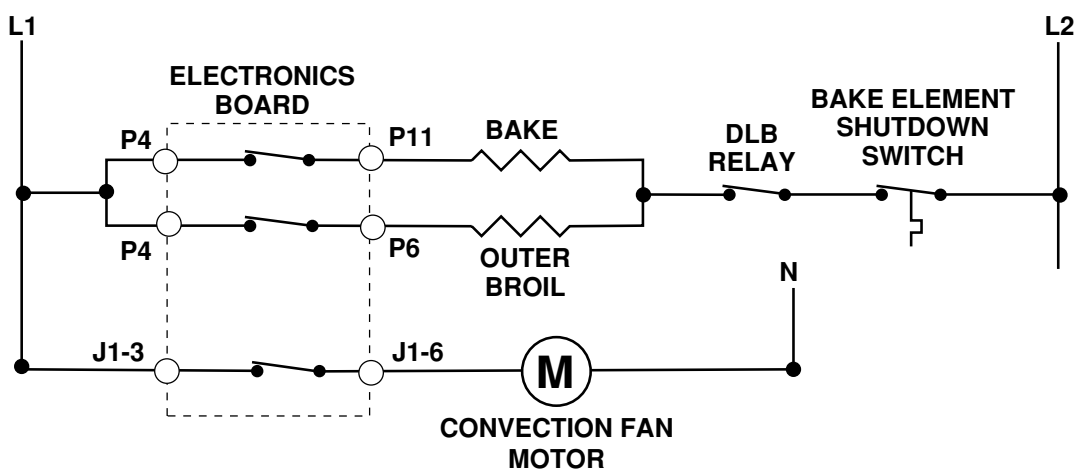

CONVECTION BROIL

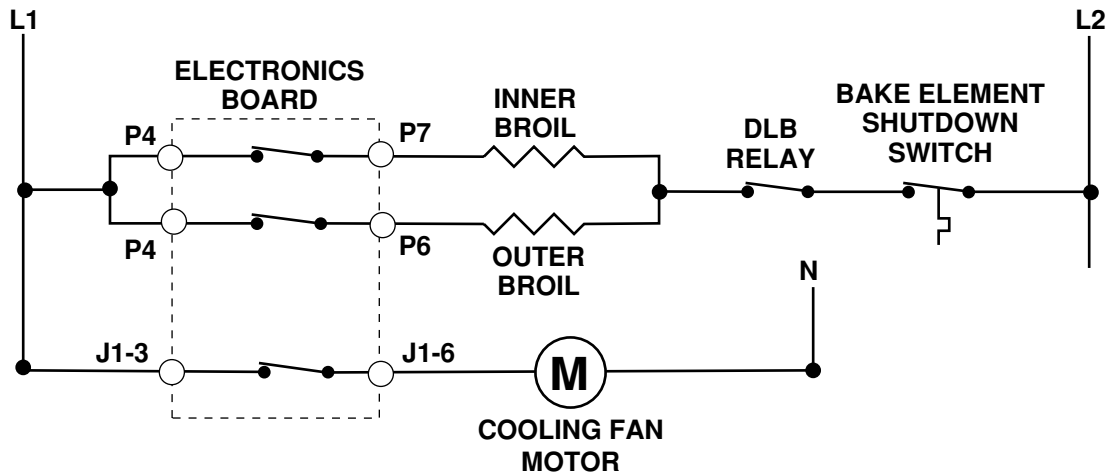

CONVECTION BAKE, DEHYDRATE, RAISING BREAD

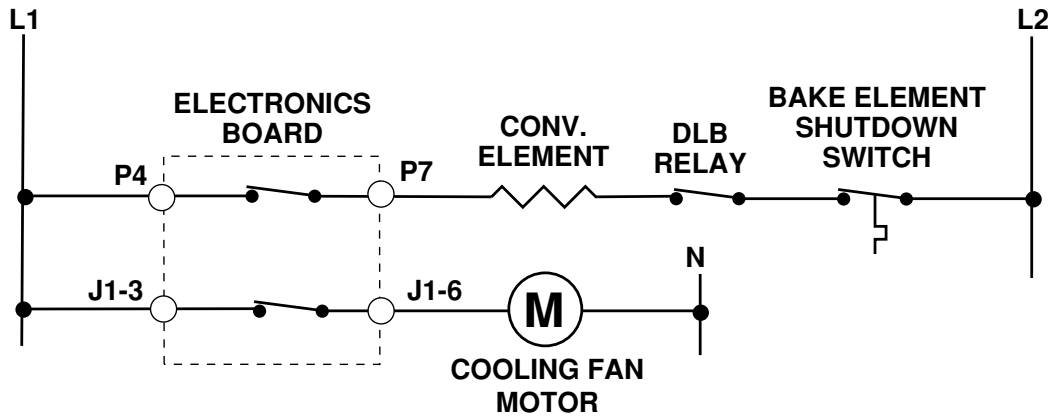

OVEN LIGHT

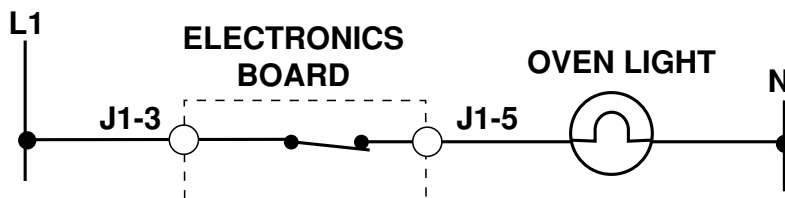

Wiring Diagram *Gas Ranges*

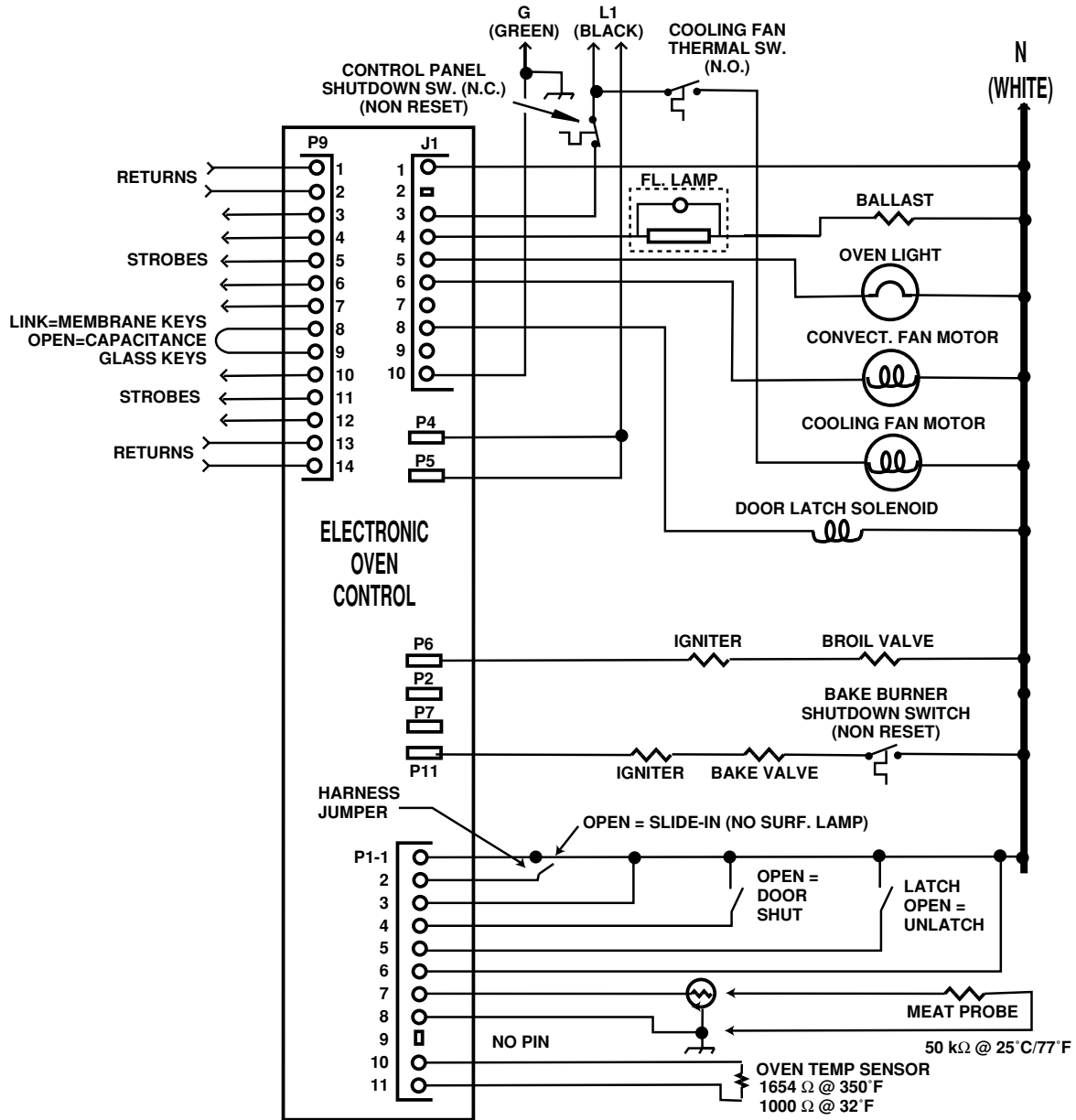
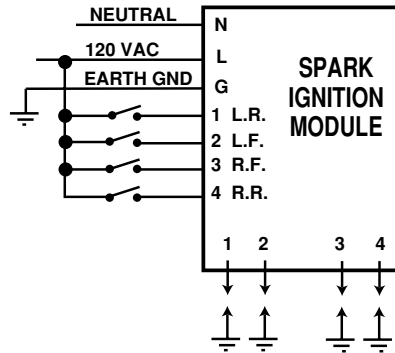

Strip Circuits

Gas Ranges

BAKE

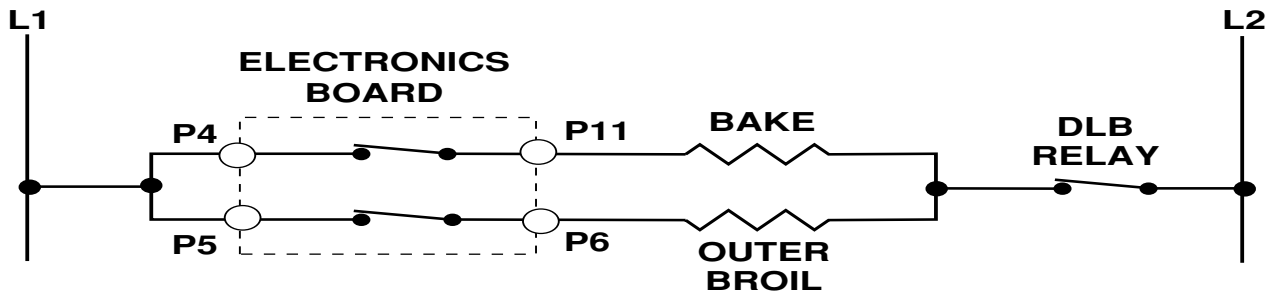

BROIL

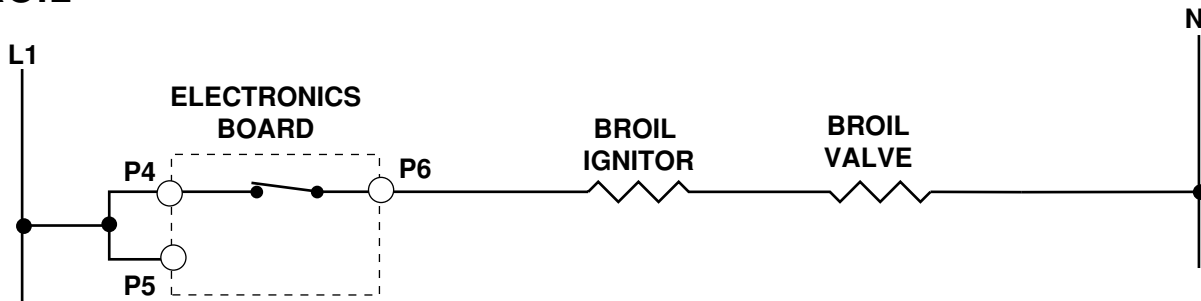

CONVECTION BAKE & ROAST

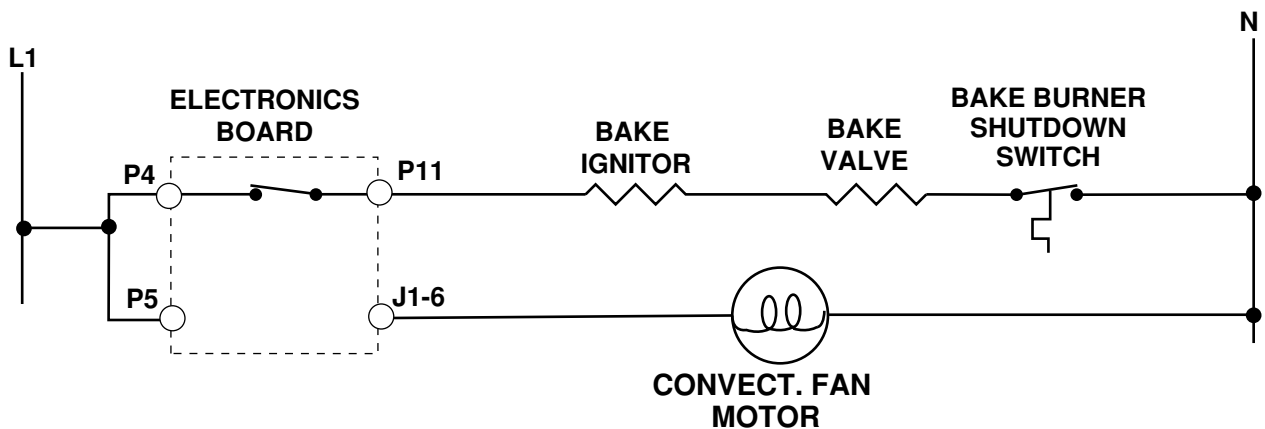

CONVECTION BROIL

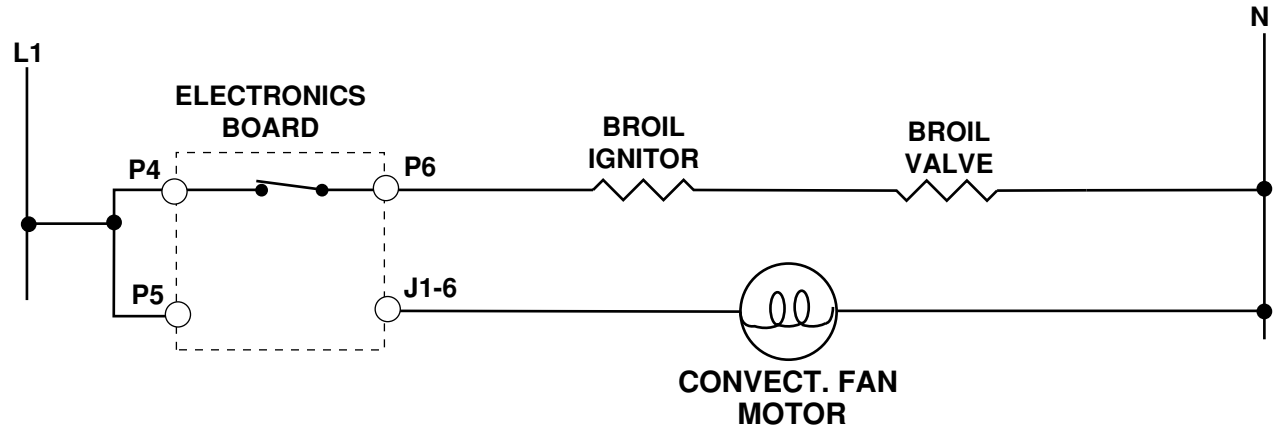

CLEAN First 30-Minutes

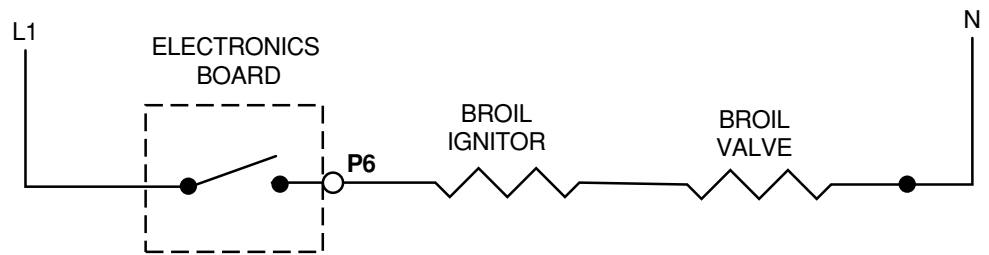

After 30-Minutes

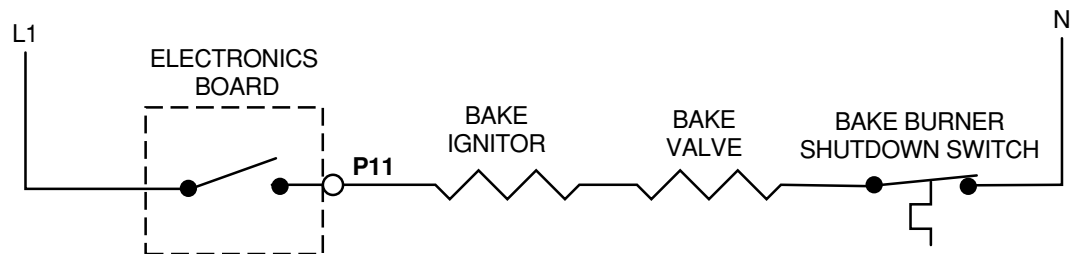

LATCH DRIVING CIRCUIT

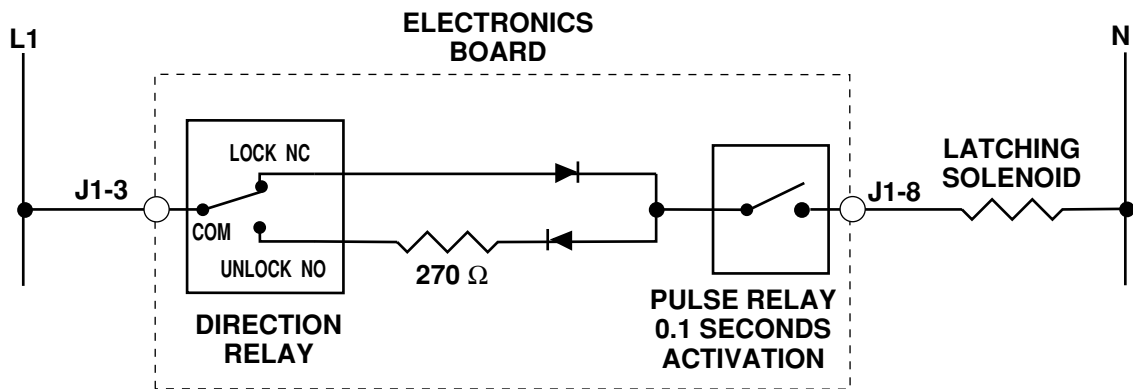

COOLING FAN MOTOR

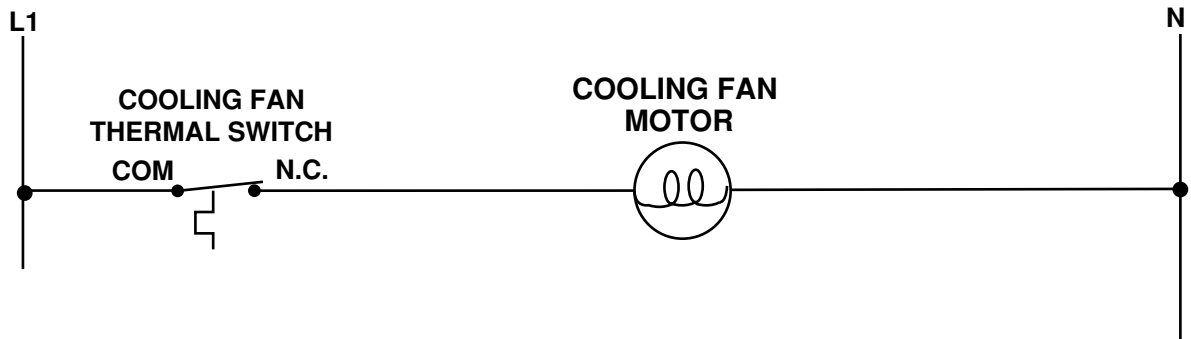

OVEN LIGHT

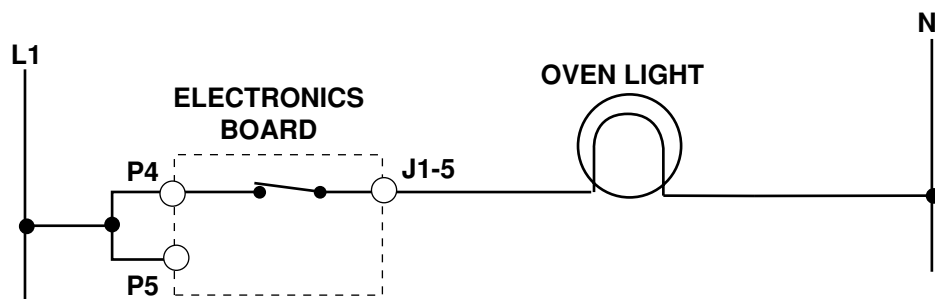

Confirmation of Understanding

1. On gas model ranges, the convection fan cycles ON for _____ - seconds and OFF for _____ - seconds in convection broil mode.
2. The oven temperature sensor mounting screw is accessed from the _____ on freestanding models, and from the _____ on slide-in models.
3. All Gas model ranges are shipped with LP conversion orifice kits:
_____ True _____ False.
4. Replacement service controls DO NOT have to be programmed to meet the range configuration they are being used in, otherwise an F-code will occur:
_____ True _____ False.
5. A cooling fan is used to maintain optimum temperatures in the console area of gas ranges only: _____ True _____ False.
6. A _____ speed fan, located in the storage drawer area, is used on freestanding and slide-in ranges.
7. Restricting the _____ _____ in the cooking systems can cause premature failure of the controls and thermal switches.
8. To set the control for Celsius temperature, press and hold the #6 keypad for 5-seconds: _____ True _____ False.
9. An error code of F5 - E3 means that the range is connected to a non-polarized receptacle: _____ True _____ False.
10. The cooling fan motor can be replaced from the console area:
_____ True _____ False.

— NOTES —

Answers

1. 10-seconds & 20-seconds
2. rear & front
3. True
4. False
5. False
6. single
7. air flow
8. False
9. True
10. False

KitchenAid Electronic Range Controls

“B” Line Freestanding/Slide-In

“D” Line Built-In Wall Ovens

- **Developed by Digital Appliance Control (DAC).**
- **Used on Gas & Electric Models.**
 - Slide-In: Up front glass “Capacitive Touch” switch membrane.
 - Freestanding: Up front glass “Capacitive Touch” membrane.
 - Wall Ovens: Mylar touch membrane switch.
- **Unique Functions:**
 - **Sabbath Mode:** Allows the oven to be operated continuously during the Jewish Sabbath.
 - **Eacy Convect:** Automatically converts standard cooking times and temperatures to convection cooking times and temperatures.
 - **Full Meal Convect:** Ten preprogrammed cook cycles and one favorite cooking cycle.
- **2nd through 5th year parts only warranty.**

KitchenAid Electronic Range Controls

“B” Line Slide-In

- **Electric Models:**

- KESS300B
- KESC300B
- KESC307B
- KESH307B

- **Gas Models:**

- KGST300B
- KGST307B

KitchenAid Electronic Range Controls

"B" Line Slide-In

Keypad Layout

Convection Slide-In

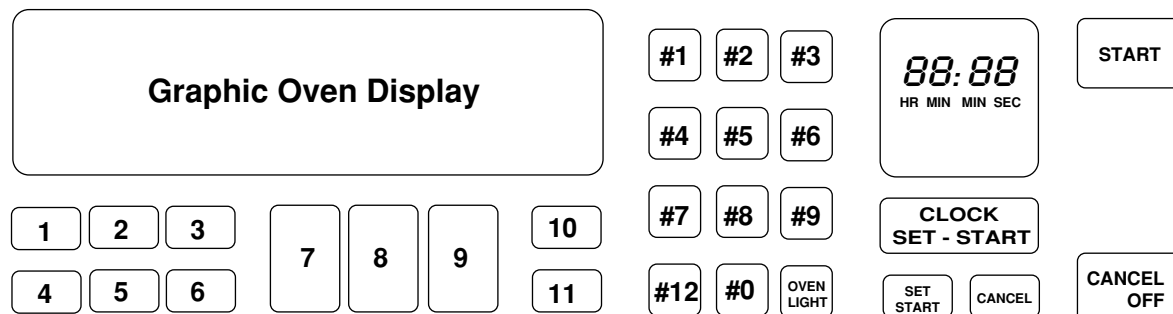

Keypad Layout

Non-Convection Slide-In

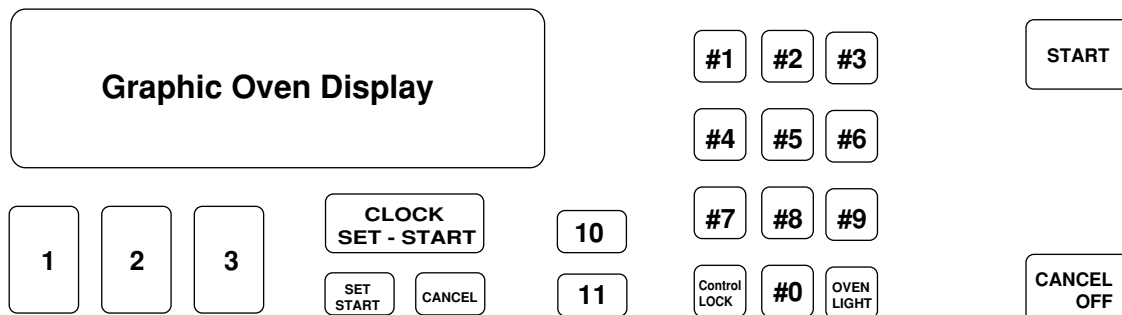

Keypads:

- 1 = Bake
- 2 = Broil
- 3 = Clean
- 4 = Convection Bake
- 5 = Convection Broil
- 6 = Convection Roast
- 7 = Easy Convection (Baked Goods)
- 8 = Easy Convection (Meats)
- 9 = Easy Convection (Other Foods)
- 10 = Cook Time
- 11 = Stop Time
- 12 = Convection Full Meal

KitchenAid Electronic Range Controls

“B” Line Freestanding

- **Electric Models (Available in late 1995):**
 - KERS500B
 - KERC500B
 - KERC507B
 - KERH507B

- **Gas Models:**
 - KGRT500B
 - KGRT507B

KitchenAid Electronic Range Controls

“B” Line Freestanding

Keypad Layout

Convection Freestanding

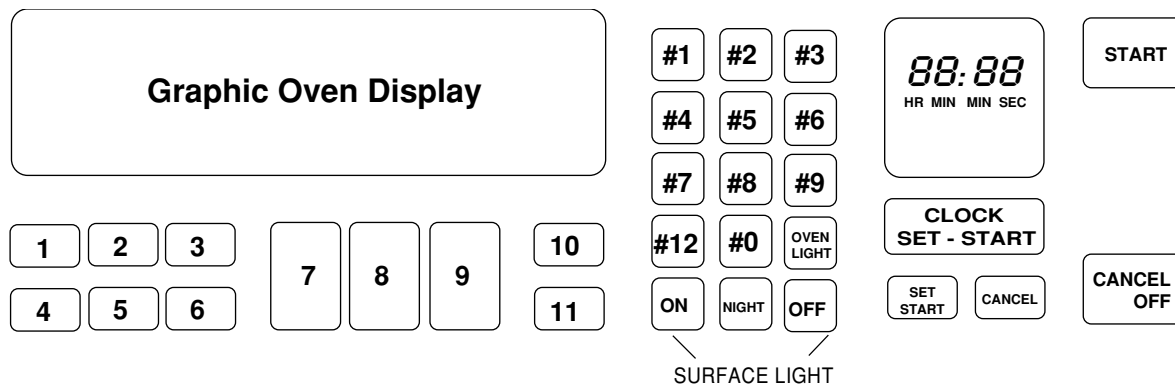

Keypad Layout

Non-Convection Freestanding

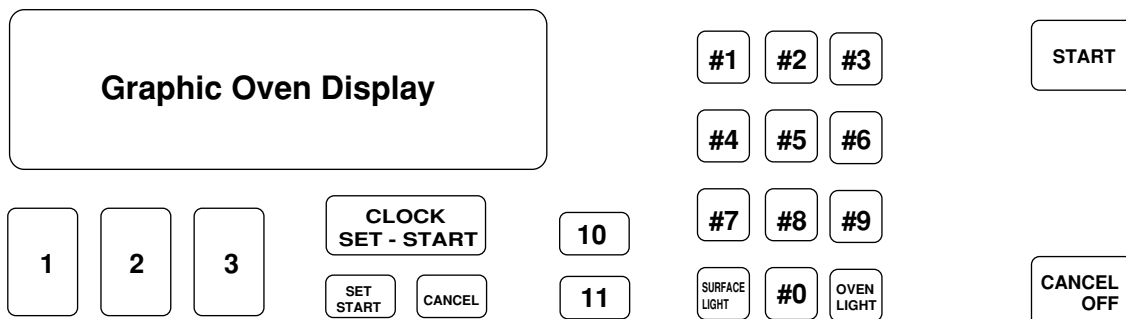

Keypads:

- 1 = Bake
- 2 = Broil
- 3 = Clean
- 4 = Convection Bake
- 5 = Convection Broil
- 6 = Convection Roast
- 7 = Easy Convection (Baked Goods)
- 8 = Easy Convection (Meats)
- 9 = Easy Convection (Other Foods)
- 10 = Cook Time
- 11 = Stop Time
- 12 = Convection Full Meal

KitchenAid Electronic Range Controls

"B" Line Freestanding/Slide-In

NOTE:
Ring element used on electric models only.

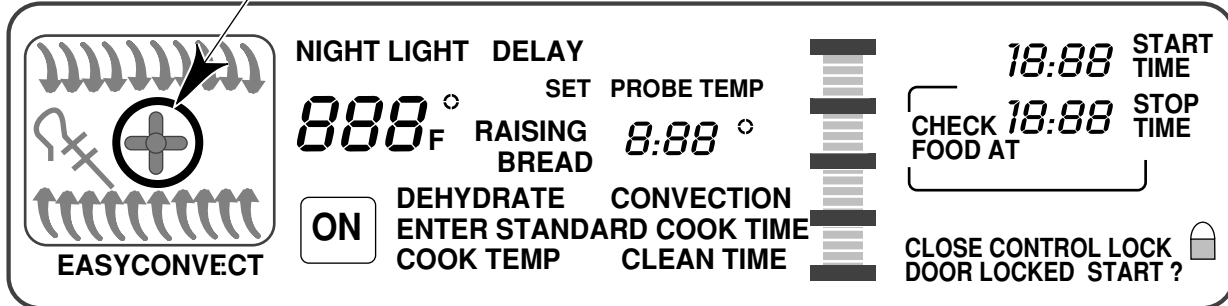

The control panel for convection models features a digital display and several function buttons. On the left, there is a graphic of a ring element with a plus sign and the text "EASYCONVECT". The main display shows "888" with a degree symbol and "F". To the right of the display are buttons for "NIGHT LIGHT", "DELAY", "SET PROBE TEMP", "RAISING BREAD", and "8:88" with a degree symbol. Further right is a vertical stack of seven buttons. Below the display is an "ON" button. At the bottom, there are buttons for "DEHYDRATE", "CONVECTION ENTER STANDARD COOK TIME", "COOK TEMP", and "CLEAN TIME". On the far right, there is a "CHECK FOOD AT" display showing "18:88" and "STOP TIME", and a "CLOSE CONTROL LOCK DOOR LOCKED START?" button with a lock icon.

CONVECTION MODELS

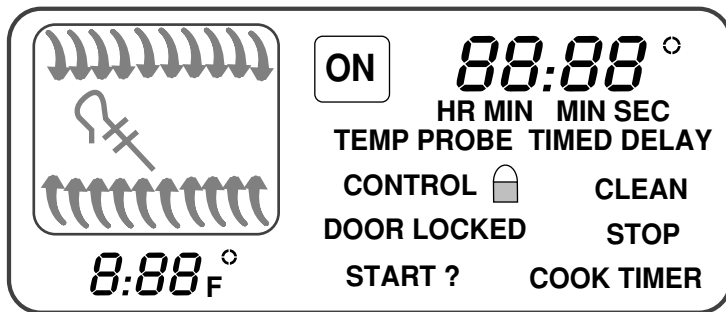

The control panel for nonconvection models features a digital display and several function buttons. On the left, there is a graphic of a ring element with a plus sign and the text "EASYCONVECT". The main display shows "8:88" with a degree symbol and "F". To the right of the display are buttons for "ON", "HR MIN MIN SEC", "TEMP PROBE TIMED DELAY", "CONTROL" with a lock icon, "CLEAN", "DOOR LOCKED", "STOP", "START?", and "COOK TIMER".

NONCONVECTION MODELS

KitchenAid Electronic Range Controls

“D” Line Wall Ovens

- **Electric Models:**

24" Ovens

KEBI141D

KEBS147D

KEBS246D

KEBS247D

27" Ovens

KEBI171D

KEBS177D

KEBS276D

KEBS277D

KEBS278D

30" Ovens

KEBI101D

KEBS107D

KEBS206D

KEBS207D

KEBS208D

KitchenAid Electronic Range Controls

“D” Line Wall Ovens

Keypad Layout Convection Single

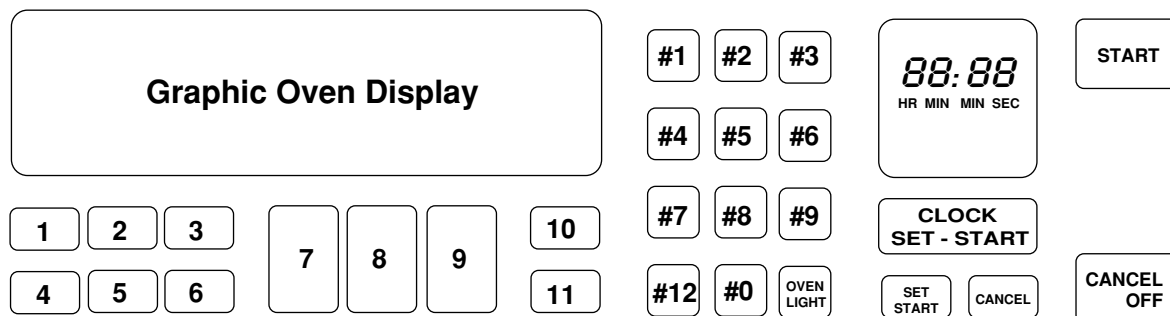

Keypad Layout Non-Convection Single

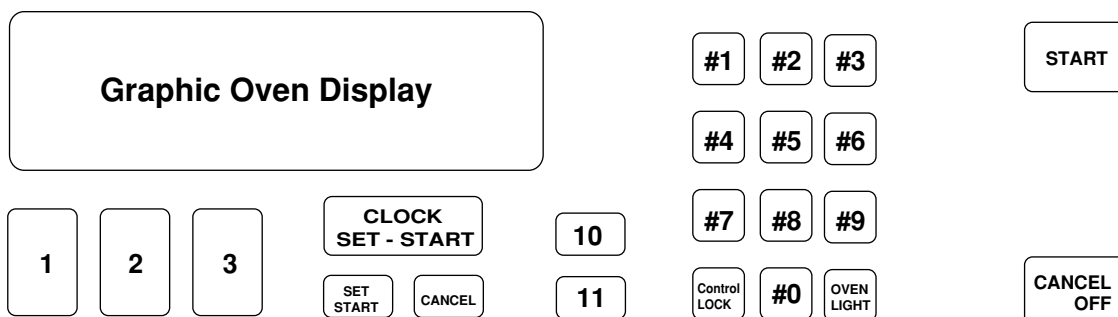

Keypads:

- 1 = Bake
- 2 = Broil
- 3 = Clean
- 4 = Convection Bake
- 5 = Convection Broil
- 6 = Convection Roast
- 7 = Easy Convection (Baked Goods)
- 8 = Easy Convection (Meats)
- 9 = Easy Convection (Other Foods)
- 10 = Cook Time
- 11 = Stop Time
- 12 = Convection Full Meal

KitchenAid Electronic Range Controls

"D" Line Wall Ovens

Keypad Layout Convection Double

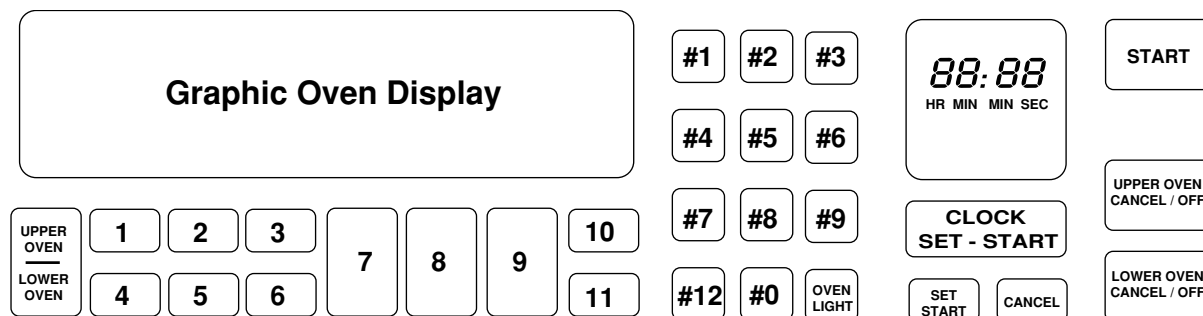

Keypad Layout Non-Convection Double

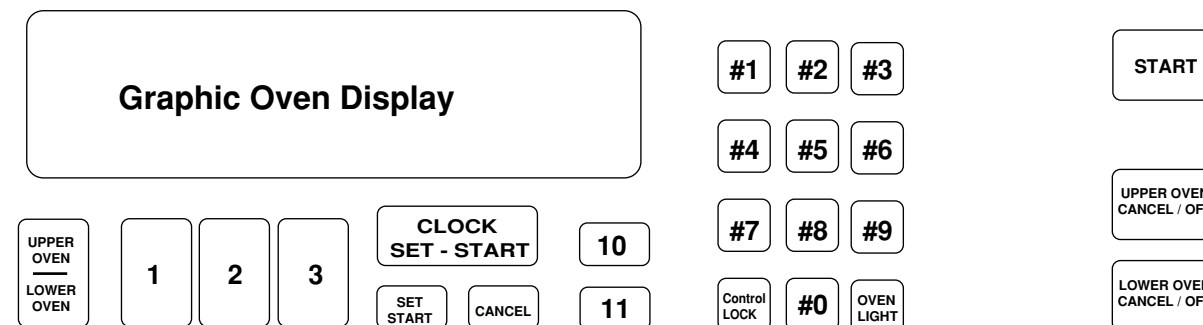

Keypads:

- 1 = Bake
- 2 = Broil
- 3 = Clean
- 4 = Convection Bake
- 5 = Convection Broil
- 6 = Convection Roast
- 7 = Easy Convection (Baked Goods)
- 8 = Easy Convection (Meats)
- 9 = Easy Convection (Other Foods)
- 10 = Cook Time
- 11 = Stop Time
- 12 = Convection Full Meal

KitchenAid Electronic Range Controls

"D" Line Wall Ovens

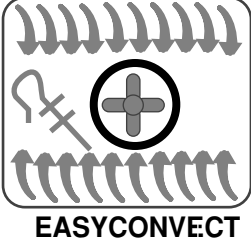

EASYCONNECT

DELAY
888[°]_F SET PROBE TEMP
 RAISING BREAD **8:88**[°]

ON DEHYDRATE CONVECTION
 ENTER STANDARD COOK TIME
 COOK TEMP CLEAN TIME

18:88 START TIME
 CHECK **18:88** STOP TIME
 FOOD AT

CLOSE CONTROL LOCK DOOR LOCKED START ? 

CONVECTION SINGLE

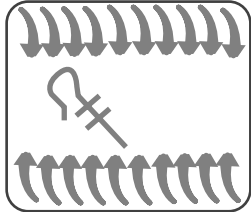

ON **88:88**[°]
 HR MIN MIN SEC
 TEMP PROBE TIMED DELAY

CONTROL  CLEAN
 DOOR LOCKED STOP

8:88[°]_F START ? COOK TIMER

NON-CONVECTION SINGLE

KitchenAid Electronic Range Controls

"D" Line Wall Ovens

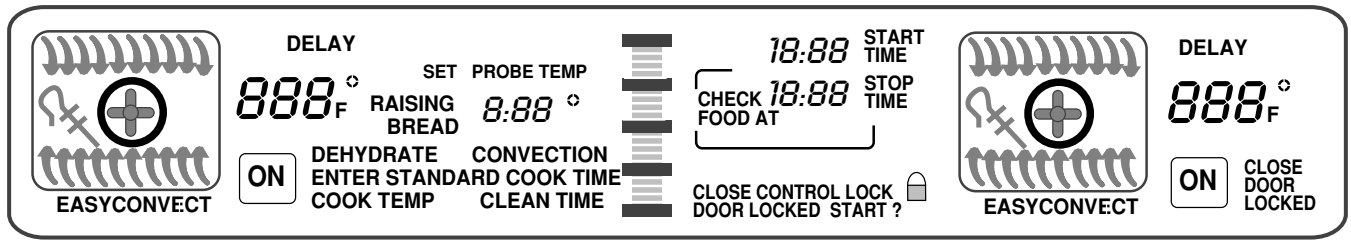

CONVECTION DOUBLE

NON-CONVECTION DOUBLE

Reading The Graphic Display

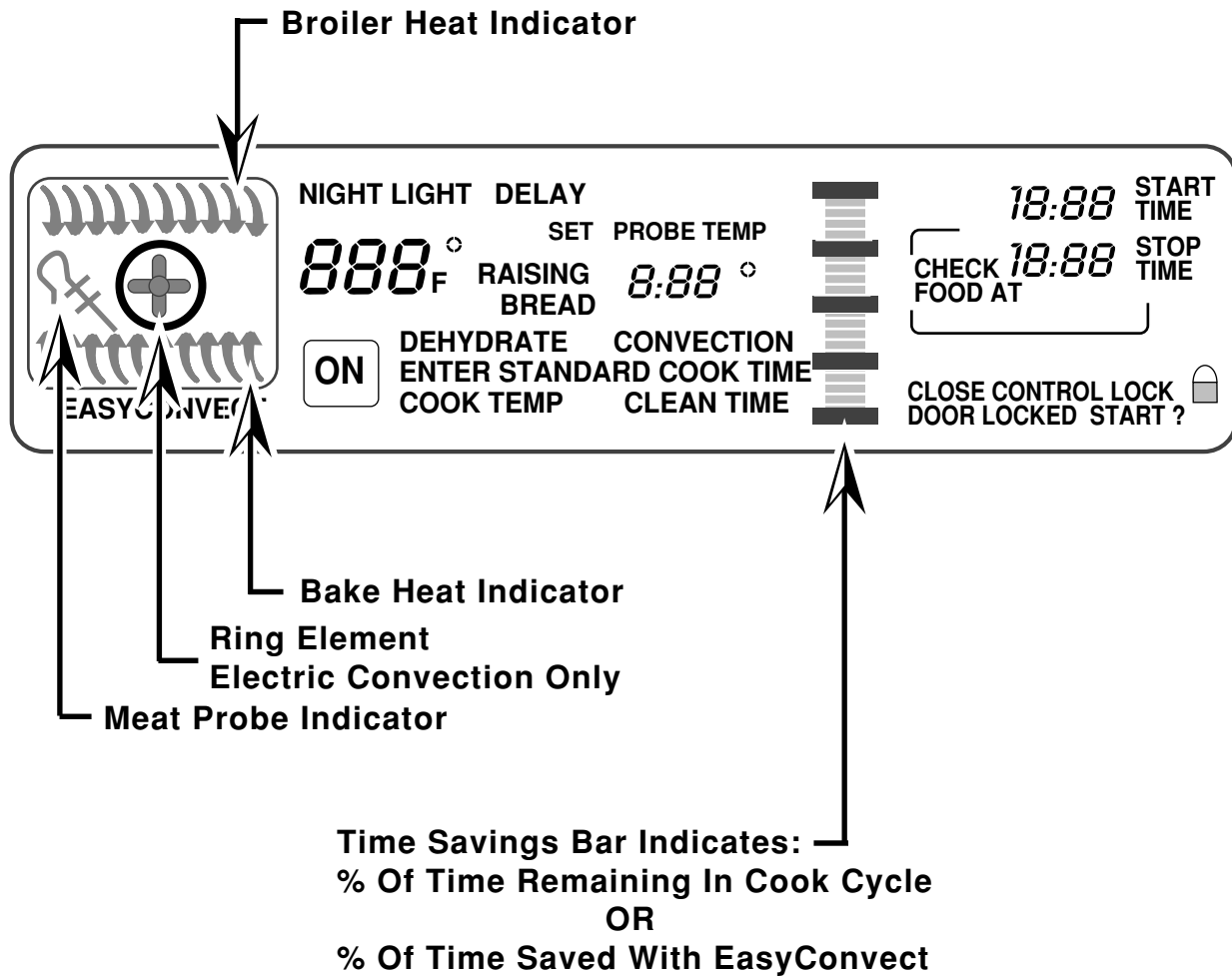

KitchenAid Electronic Range Controls “Easy Convect”

- **Available on convection models only.**
- **Allows the consumer to cook standard oven recipes in the convection mode.**
- **Three Easy Convect cooking functions:**
 - **Baked Goods: Converts time by –50% and temperature by –50° F.**
 - **Meats: Converts time by –20% and temperature by –25° F.**
 - **Other: Converts time by –10% and temperature by –25° F.**
- **Let’s review the operation of the Easy Convect cycle. We will use the “Meats” cycle to show how it works.**

KitchenAid Electronic Range Controls

“Easy Convect (Meats)”

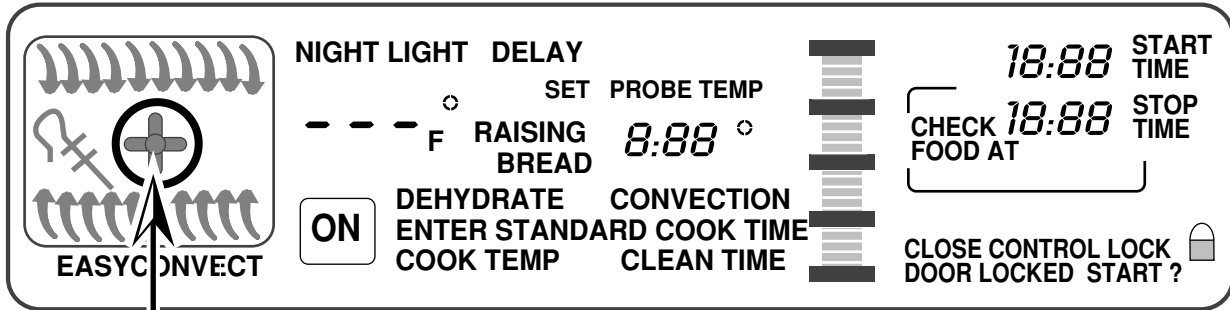

NOTE:
Ring element used
on electric models
only.

CONVECTION MODELS

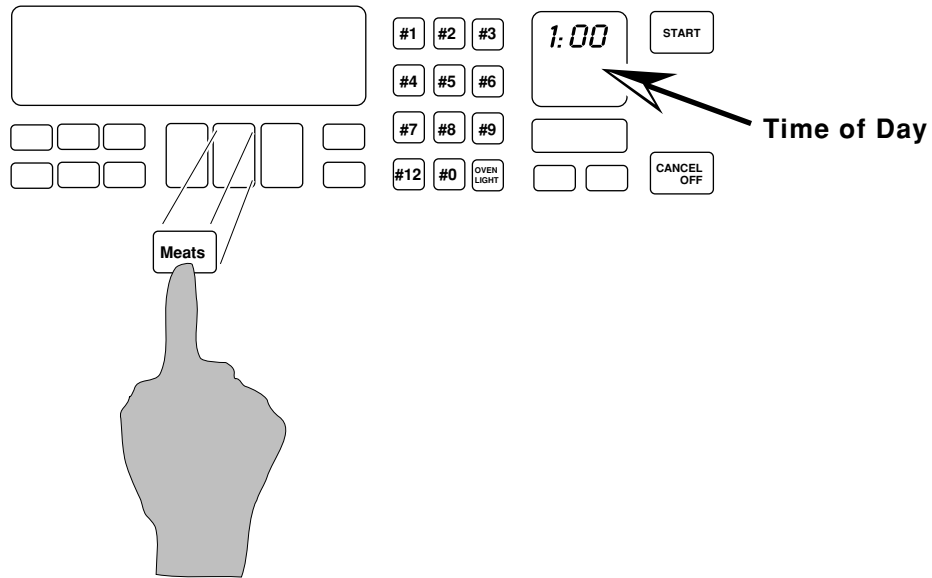

Press the “Meats” keypad.

KitchenAid Electronic Range Controls

“Easy Convect (Meats)”

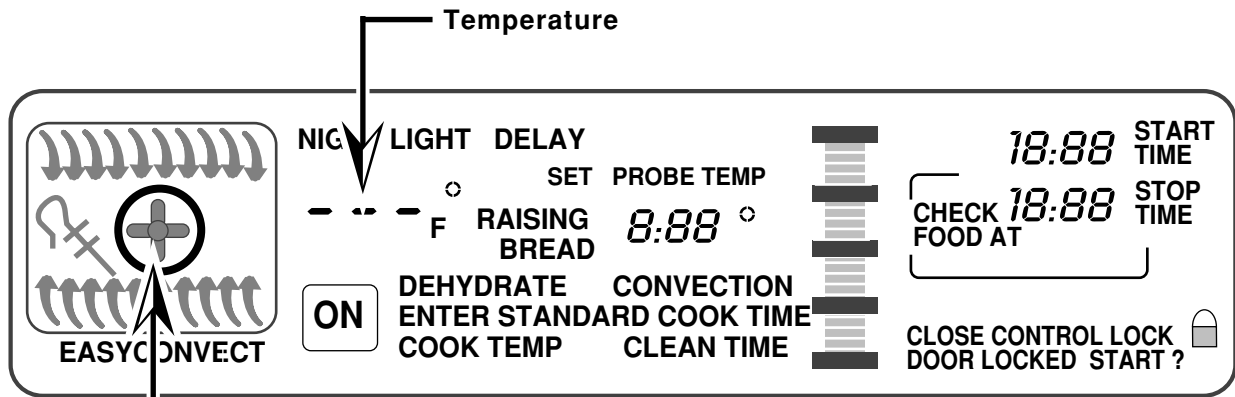

NOTE:
Ring element used on electric models only.

CONVECTION MODELS

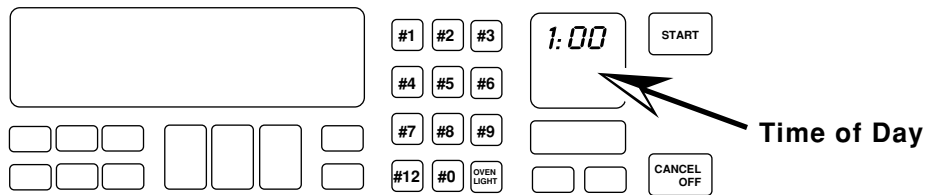

Enter the normal cooking temperature.

KitchenAid Electronic Range Controls

“Easy Convection (Meats)”

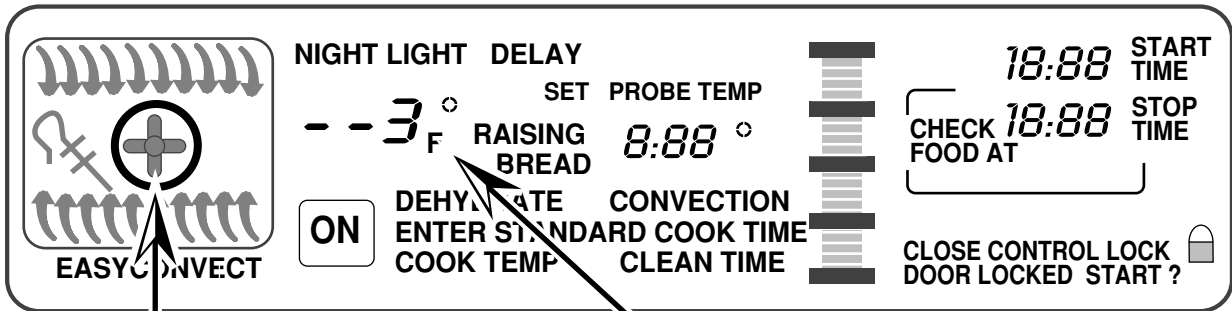

NOTE:
Ring element used
on electric models
only.

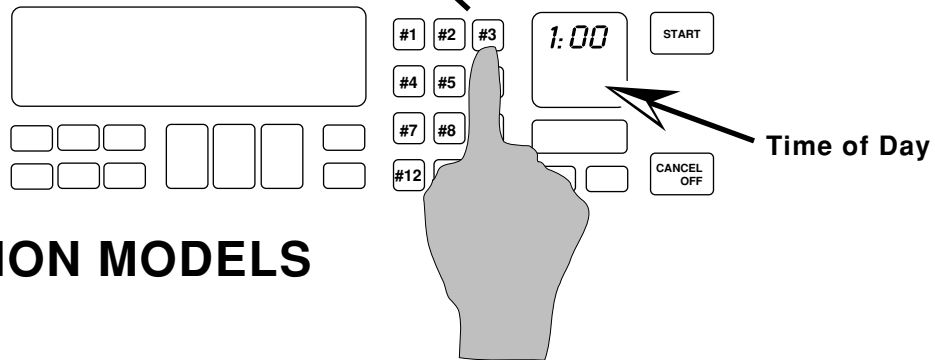

CONVECTION MODELS

Enter the normal cooking temperature.

KitchenAid Electronic Range Controls

“Easy Convect (Meats)”

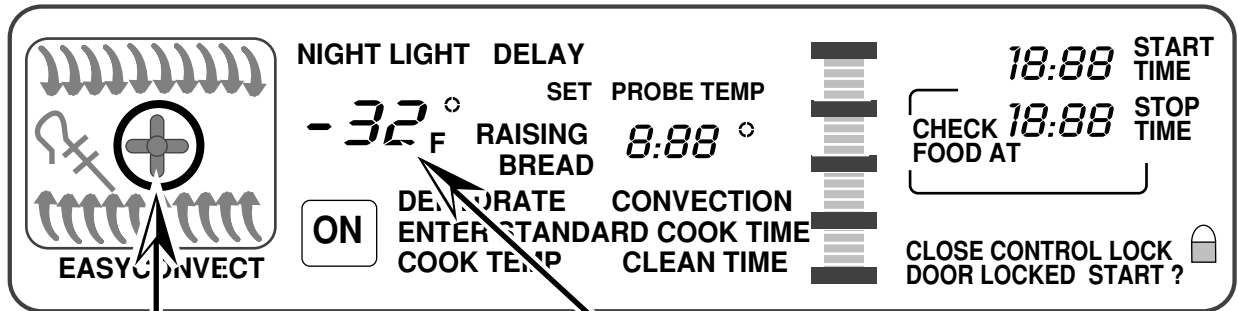

NOTE:
Ring element used
on electric models
only.

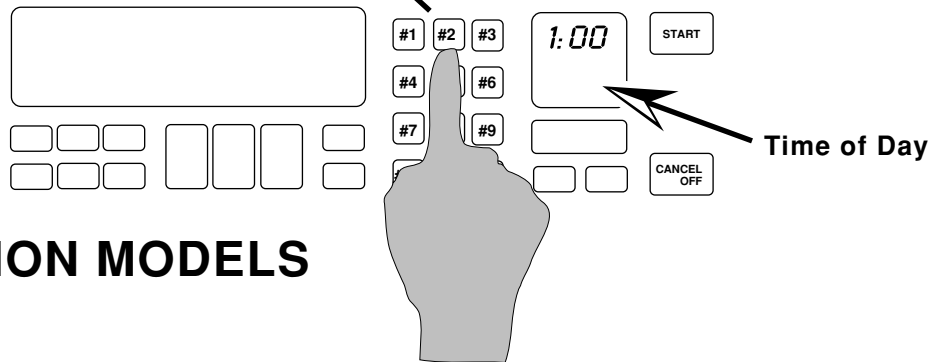

CONVECTION MODELS

Enter the normal cooking temperature.

KitchenAid Electronic Range Controls

“Easy Convect (Meats)”

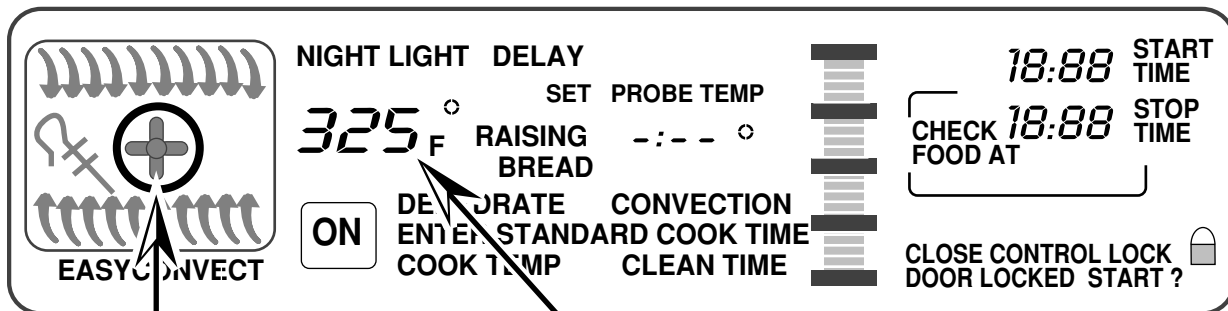

NOTE:
Ring element used
on electric models
only.

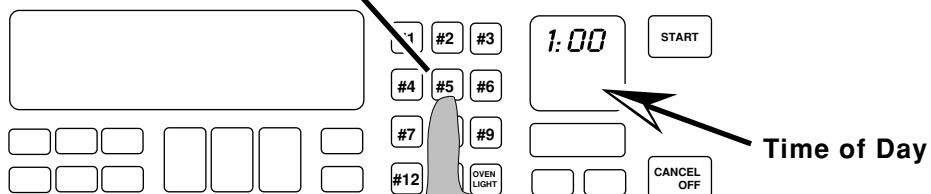

CONVECTION MODELS

Enter the normal cooking temperature.

KitchenAid Electronic Range Controls

“Easy Convect (Meats)”

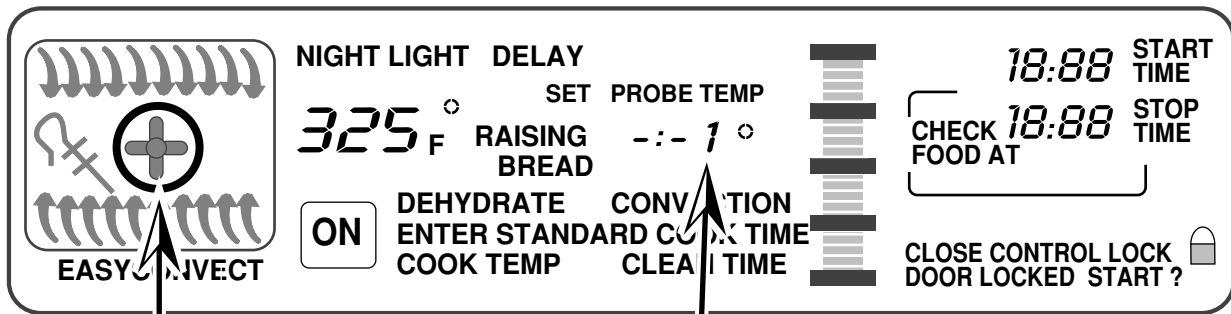

NOTE:
Ring element used
on electric models
only.

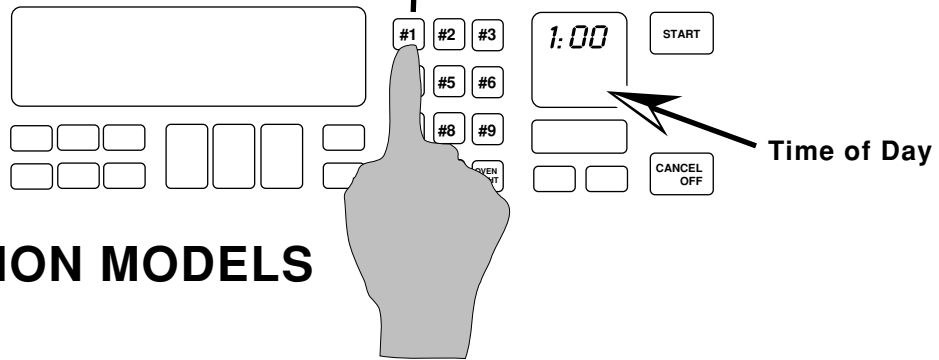

CONVECTION MODELS

Enter the normal cooking time.

KitchenAid Electronic Range Controls

“Easy Convect (Meats)”

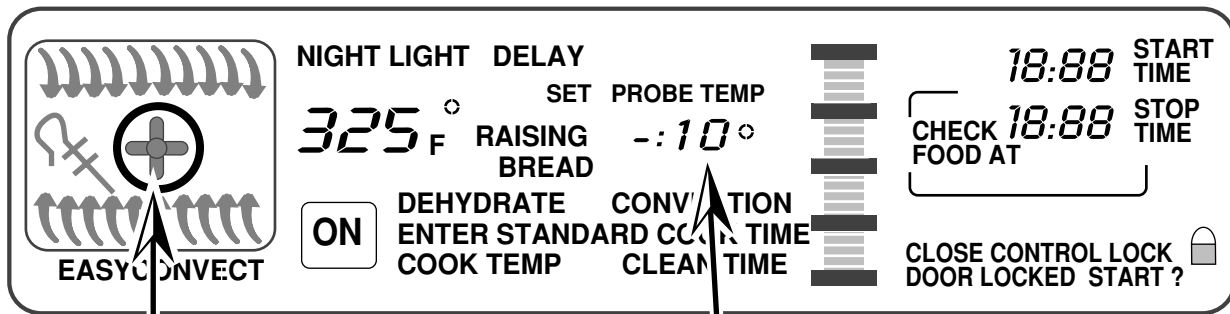

NOTE:
Ring element used
on electric models
only.

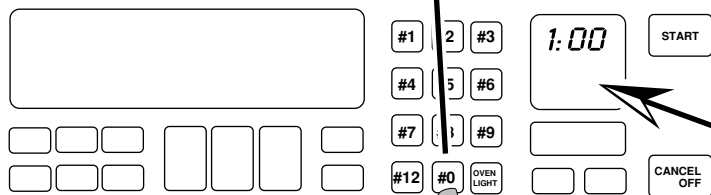

Time of Day

CONVECTION MODELS

Enter the normal cooking time.

KitchenAid Electronic Range Controls

“Easy Convect (Meats)”

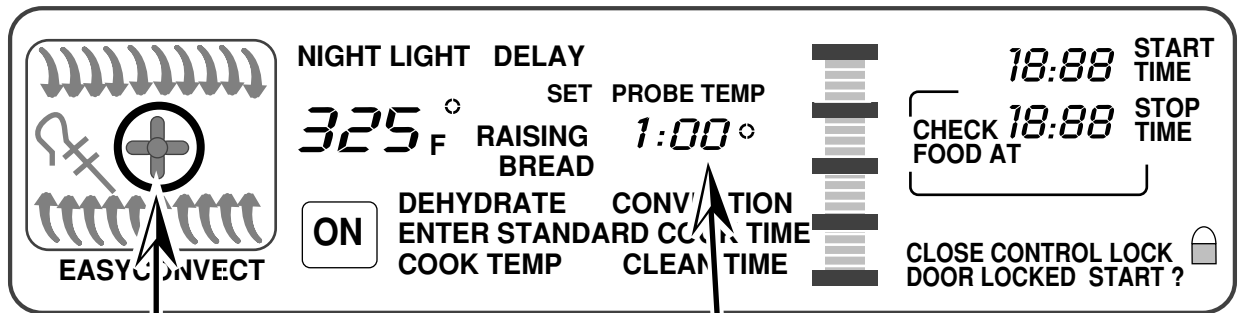

NOTE:
Ring element used
on electric models
only.

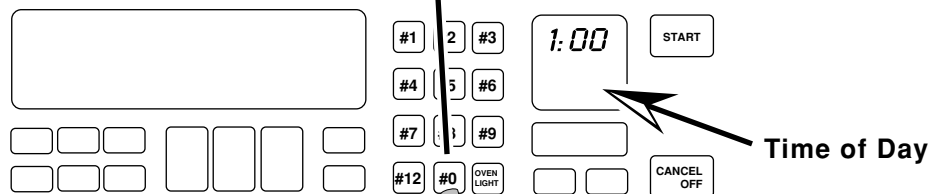

CONVECTION MODELS

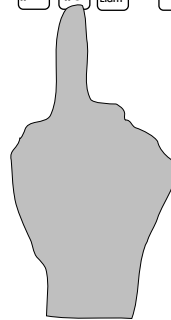

Enter the normal cooking time.

KitchenAid Electronic Range Controls

“Easy Convect (Meats)”

Temperature adjusted by 25°

Convection Cooking Time adjusted by 20%

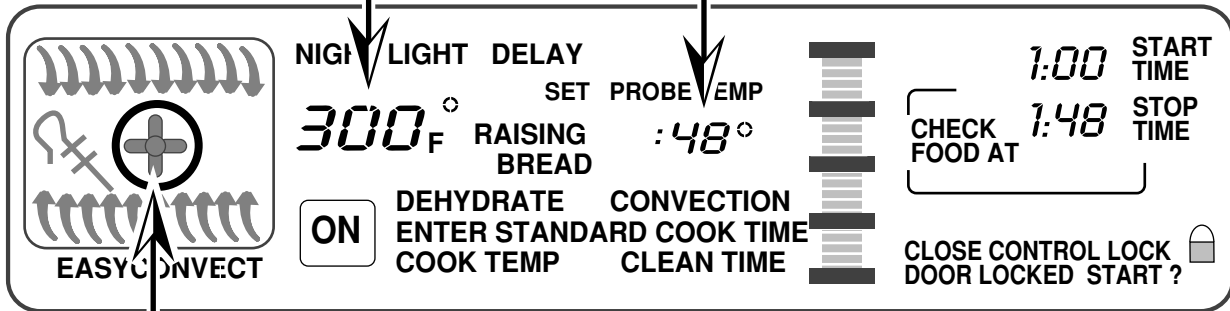

NOTE: Ring element used on electric models only.

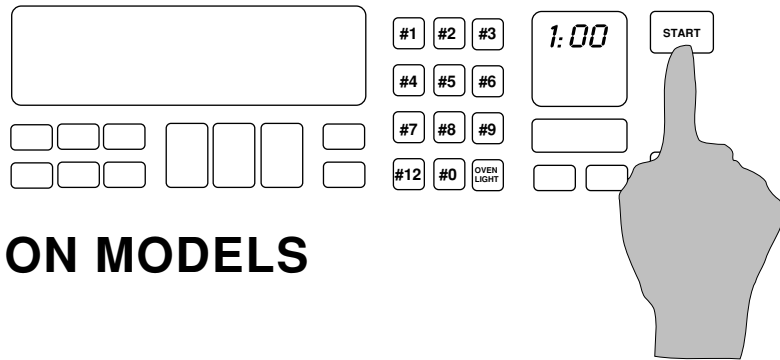

CONVECTION MODELS

Press “Start”

After the Start button is pressed, the control adjusts the convection cooking time by 20% and the temperature by 25-degrees.

KitchenAid Electronic Range Controls “Sabbath Mode”

- **Available on all KitchenAid models.**
- **Allows the consumer to meet the “No Work” requirements of the Jewish Sabbath. This means that:**
 - **The range will operate nonstop as long as power is applied to the range.**
 - **The range will resume cooking if there is a power failure while in this mode of operation (convection models will resume the “Favorite Cycle”).**
- **No tones will sound when in this mode.**
- **Touchpad responses are delayed by 1-second to prevent accidentally turning the range off.**
- **Let’s review the operation of the Sabbath Mode.**

KitchenAid Electronic Range Controls

“Sabbath Mode”

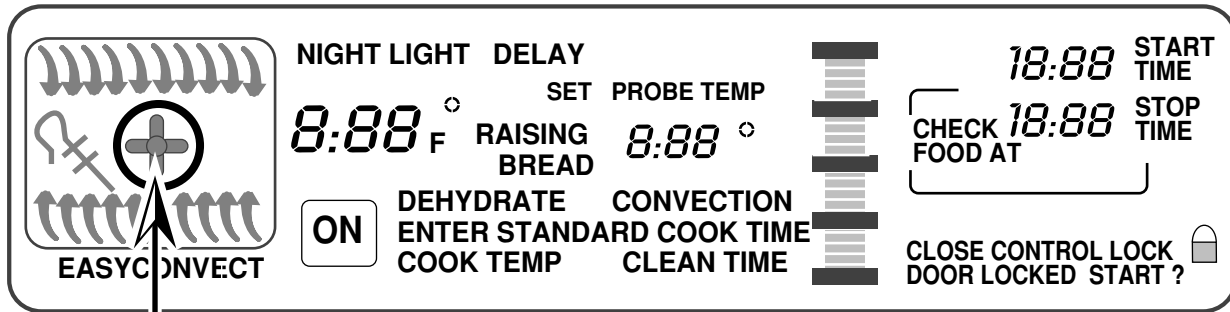

NOTE:
Ring element used
on electric models
only.

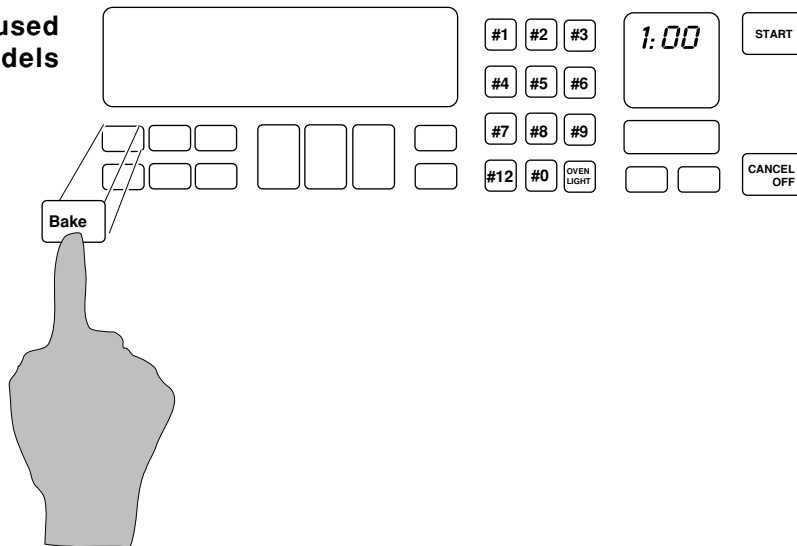

KitchenAid Electronic Range Controls

“Sabbath Mode”

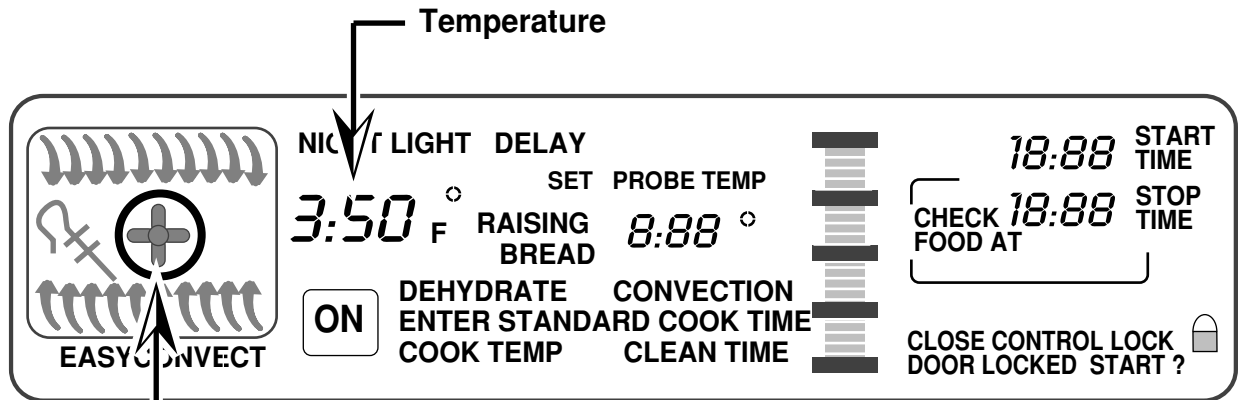

CONVECTION MODELS

NOTE:
Ring element used
on electric models
only.

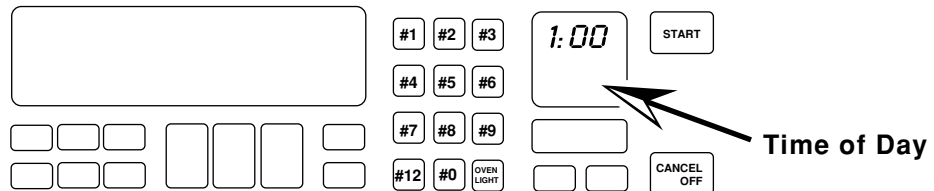

Set the temperature you desire to use during
the Sabbath Mode. We will use 375°.

KitchenAid Electronic Range Controls

“Sabbath Mode”

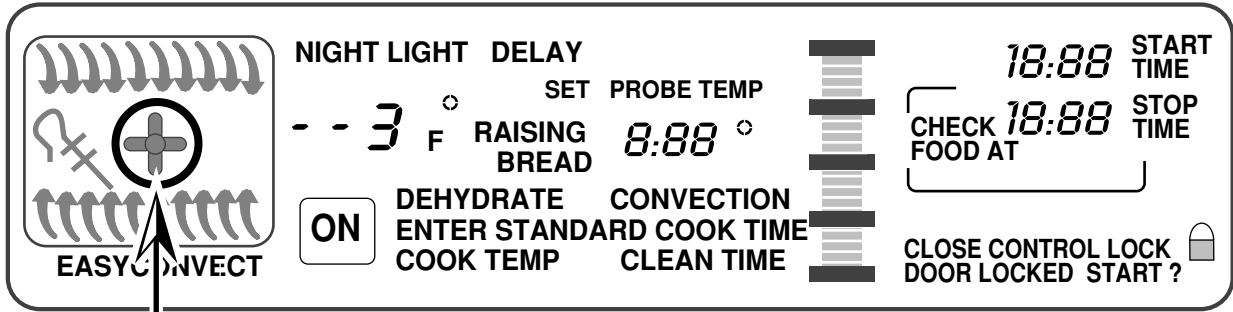

CONVECTION MODELS

NOTE:
Ring element used
on electric models
only.

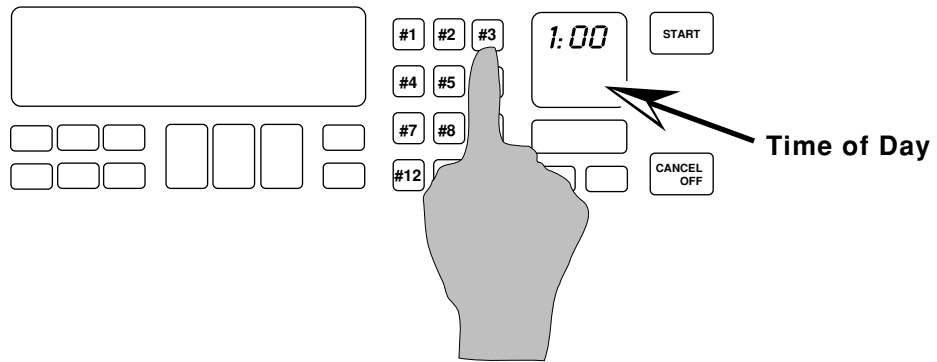

Set the temperature you desire to use during the Sabbath Mode. We will use 375°.

KitchenAid Electronic Range Controls

“Sabbath Mode”

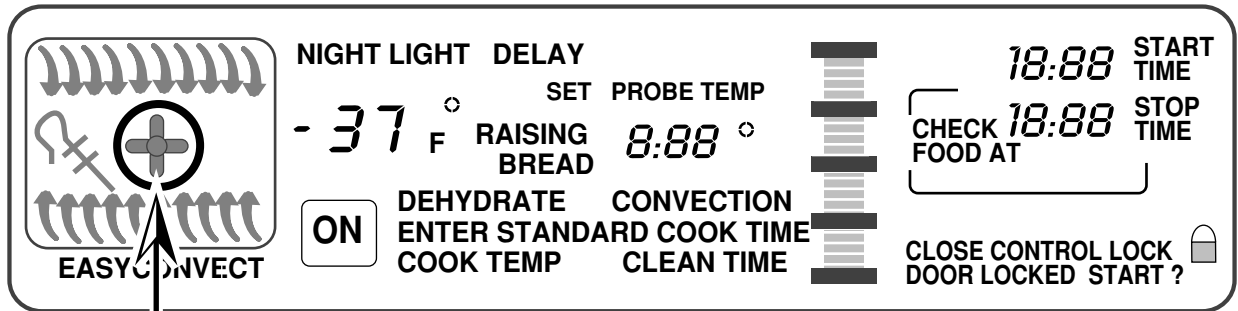

CONVECTION MODELS

NOTE:
Ring element used
on electric models
only.

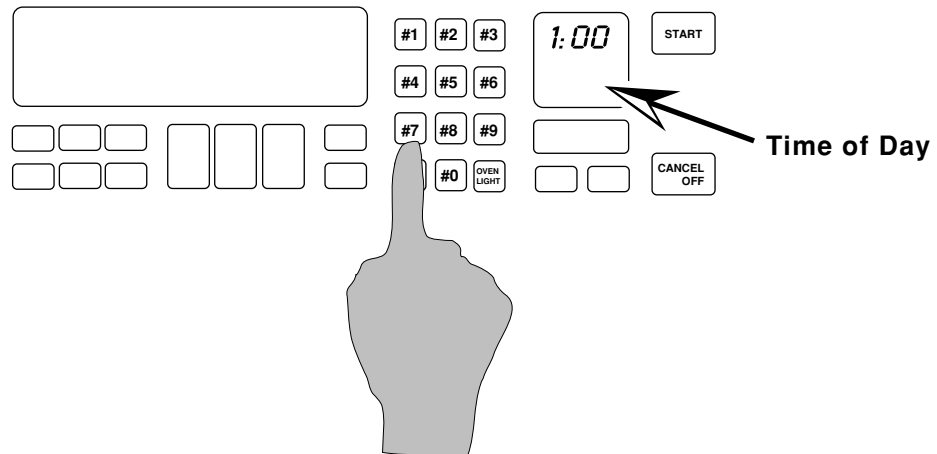

Set the temperature you desire to use during the Sabbath Mode. We will use 375°.

KitchenAid Electronic Range Controls

“Sabbath Mode”

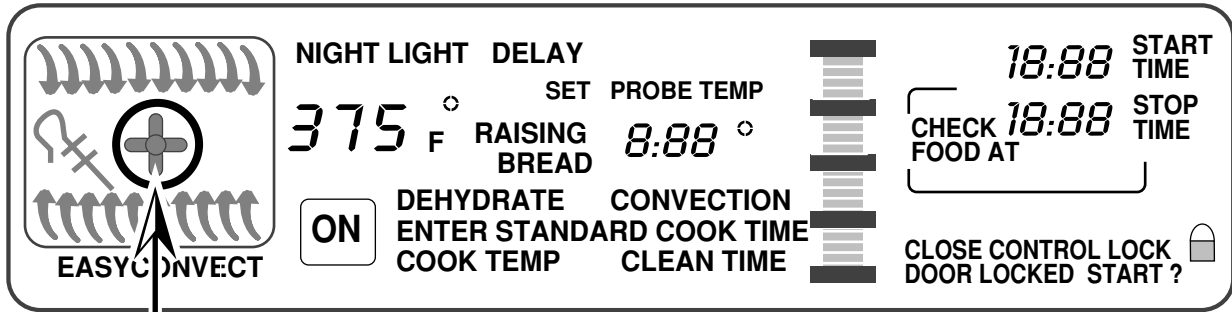

CONVECTION MODELS

NOTE:
Ring element used
on electric models
only.

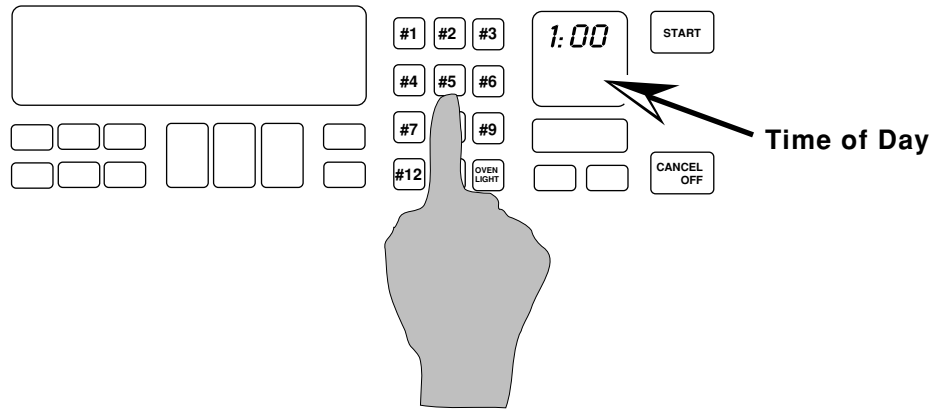

Set the temperature you desire to use during the Sabbath Mode. We will use 375°.

KitchenAid Electronic Range Controls

“Sabbath Mode”

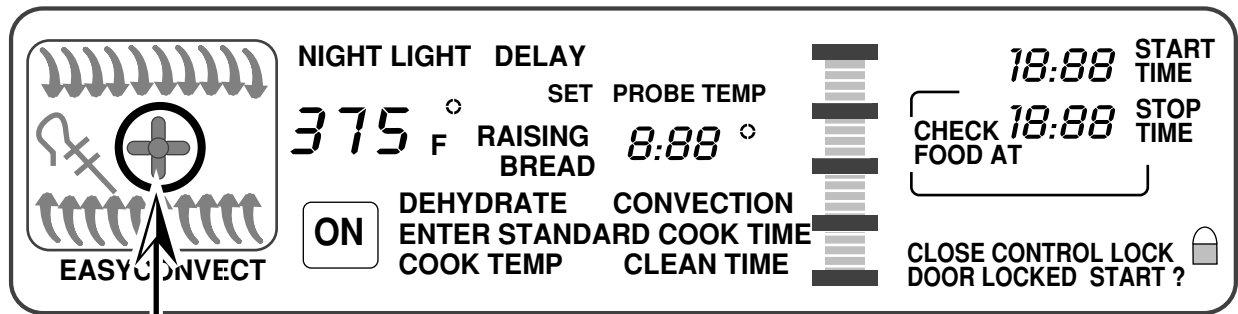

CONVECTION MODELS

Time of Day

NOTE:
Ring element used
on electric models
only.

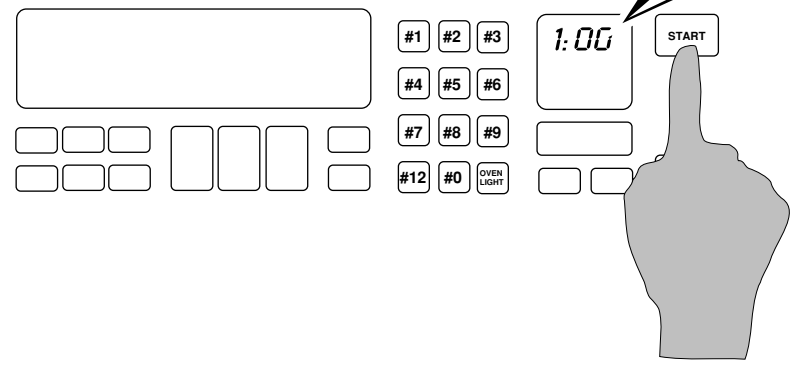

Select “Start” and the oven will preheat.

KitchenAid Electronic Range Controls

“Sabbath Mode”

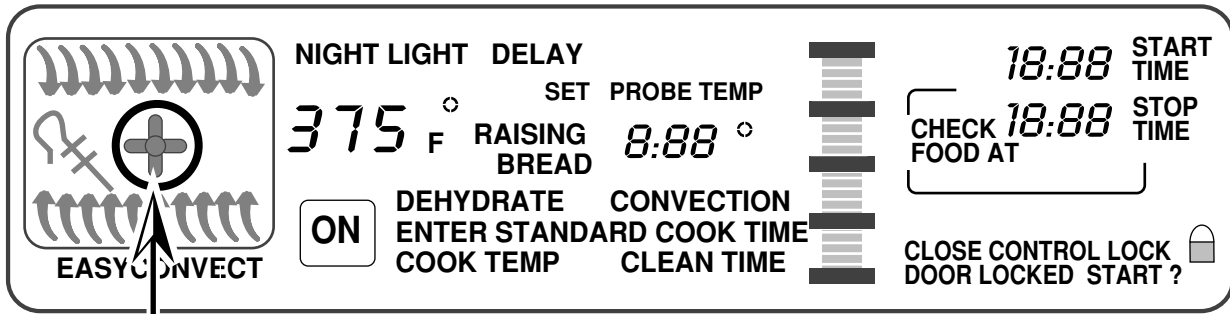

CONVECTION MODELS

NOTE:
Ring element used
on electric models
only.

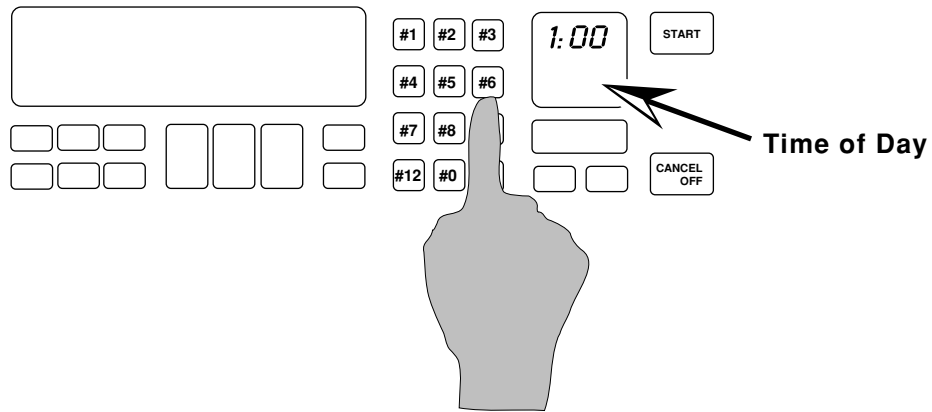

When the oven has finished preheating, press and hold the #6 keypad for 5-seconds.

KitchenAid Electronic Range Controls

“Sabbath Mode”

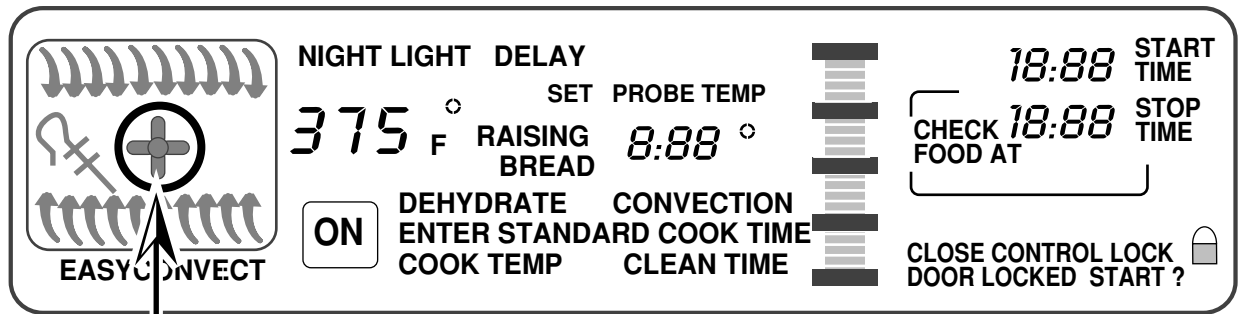

CONVECTION MODELS

NOTE:
Ring element used
on electric models
only.

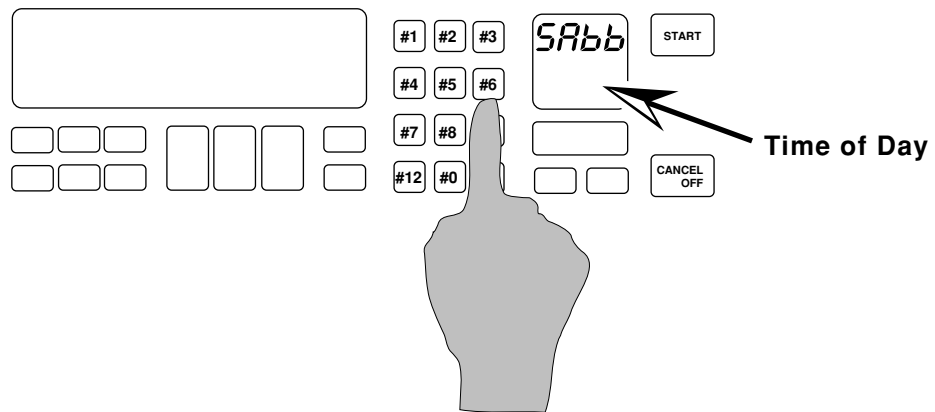

The Time of Day display changes to “SAbb.”

KitchenAid Electronic Range Controls

“Sabbath Mode”

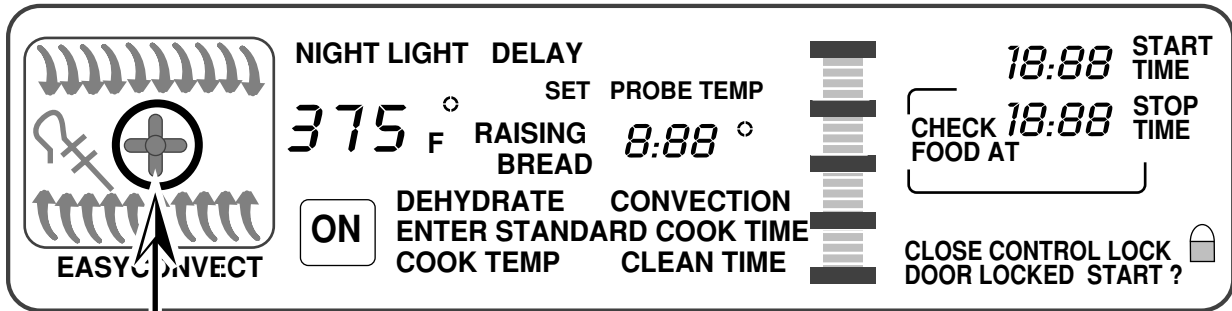

CONVECTION MODELS

NOTE:
Ring element used
on electric models
only.

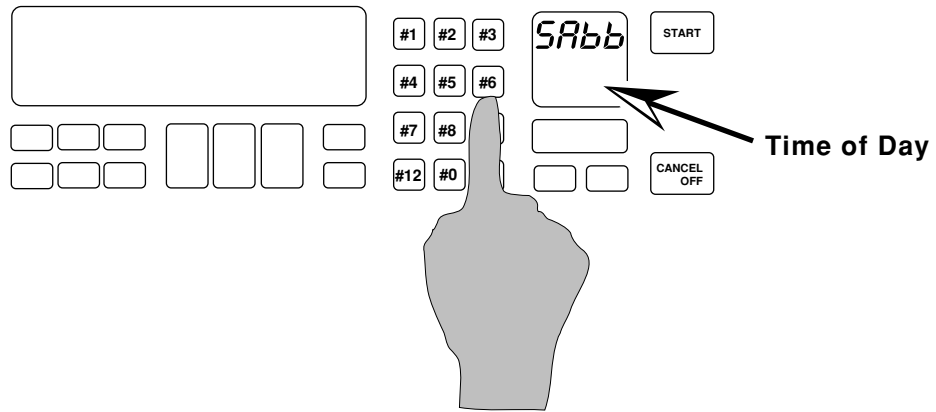

**The Sabbath Mode can only be cancelled
by pressing and holding the #6 keypad.**

KitchenAid Electronic Range Controls

“Clean Mode”

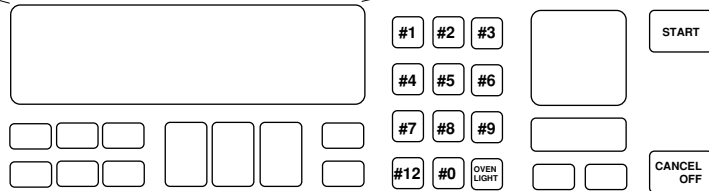
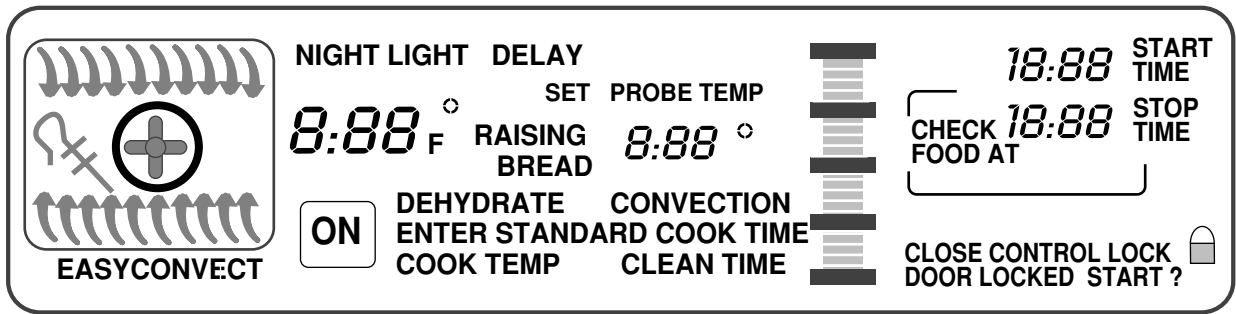

How does the oven operate in the Clean Cycle?

KitchenAid Electronic Range Controls

“Clean Mode”

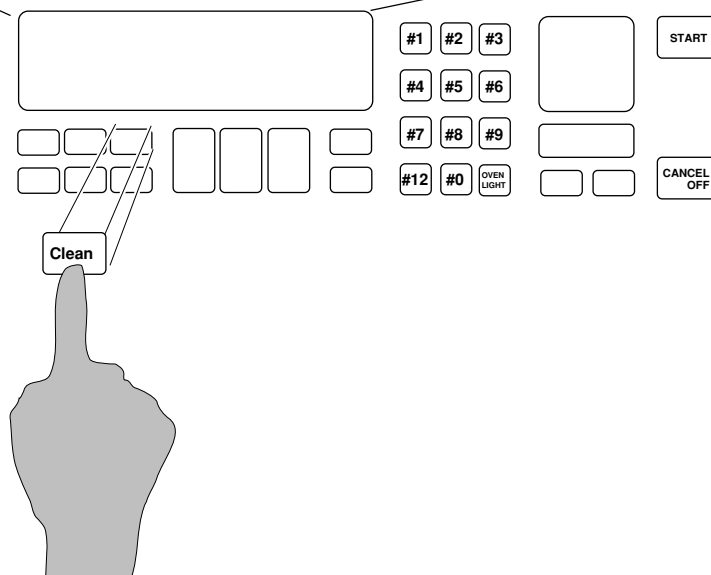
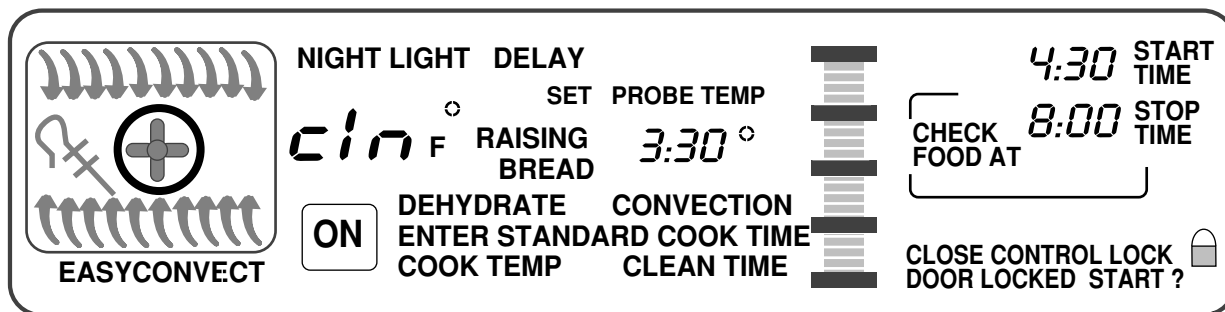

The customer selects the “Clean Mode” on the touch panel. The 3-¹/₂ hour default clean time will be displayed (the customer can select a clean cycle of between 2-¹/₂ and 4-¹/₂ hours). The Start and Stop times will be displayed (based on the time selected by the customer).

KitchenAid Electronic Range Controls

“Clean Mode”

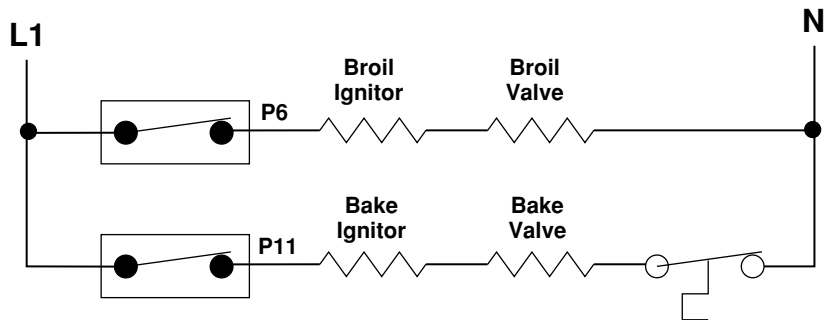
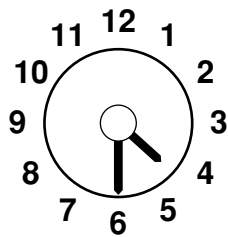
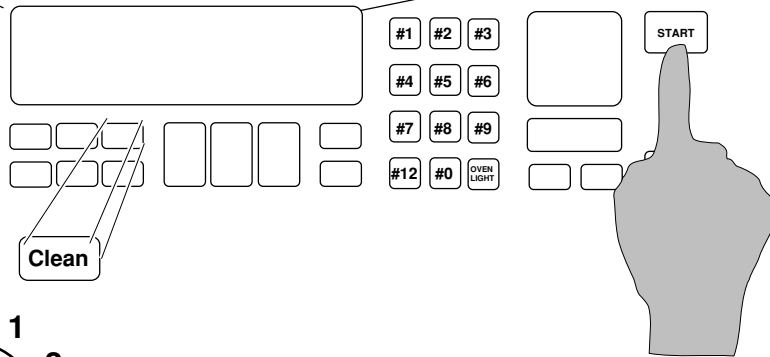
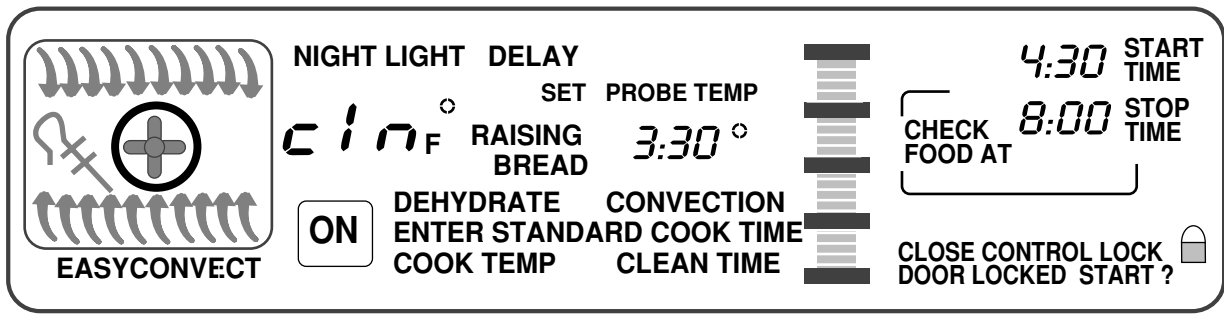

At the instant of start:

- The door will lock.
- The Broil Ignitor is ON.
- The Broil Valve is ON.
- The oven will start heating.

KitchenAid Electronic Range Controls

“Clean Mode”

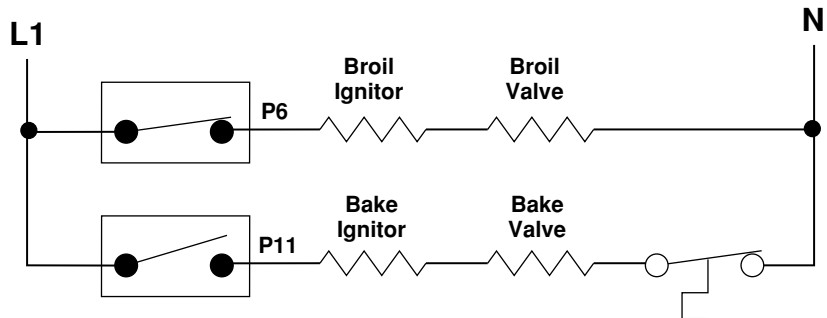
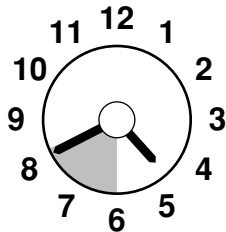
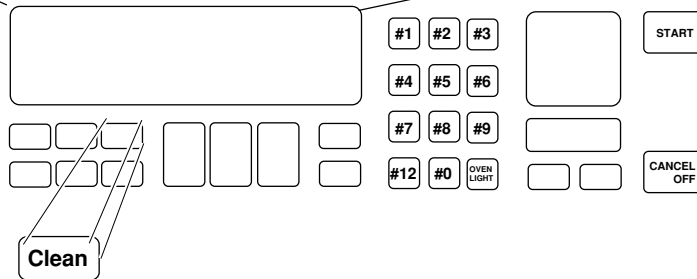
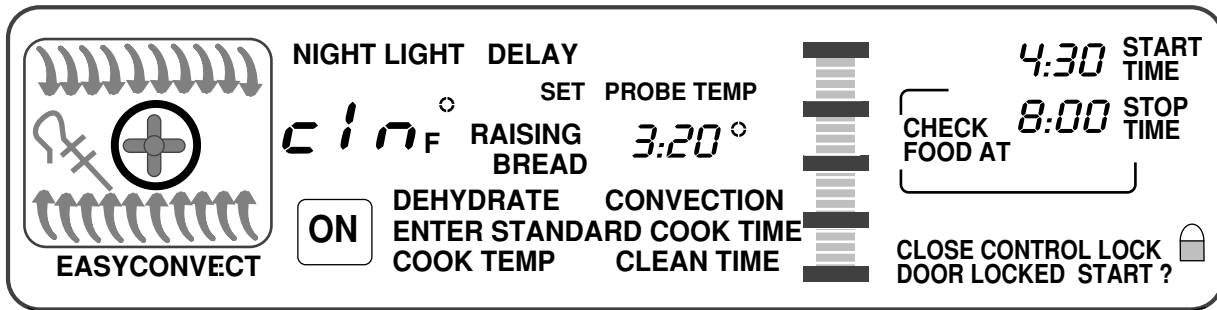

KitchenAid Electronic Range Controls

“Clean Mode”

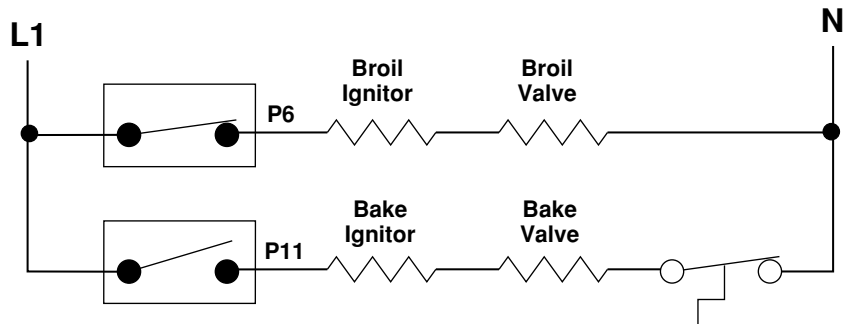
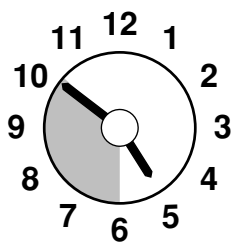
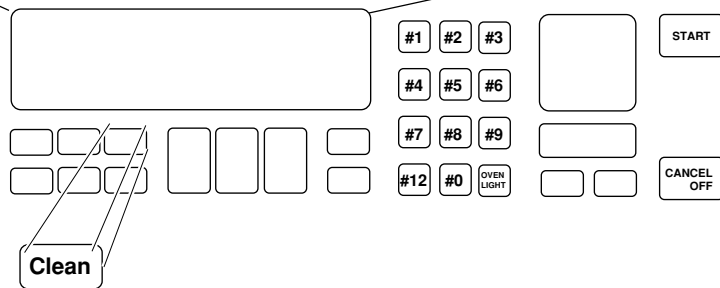
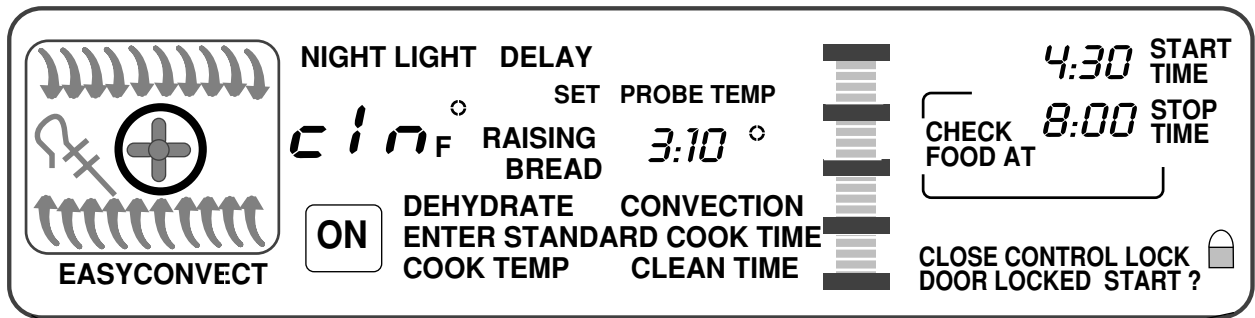

KitchenAid Electronic Range Controls

“Clean Mode”

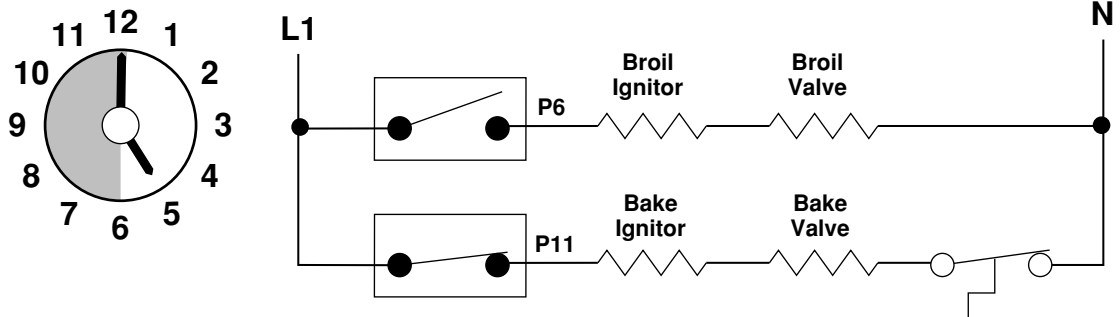
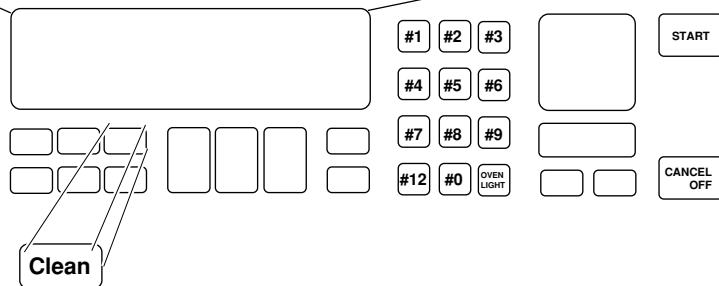
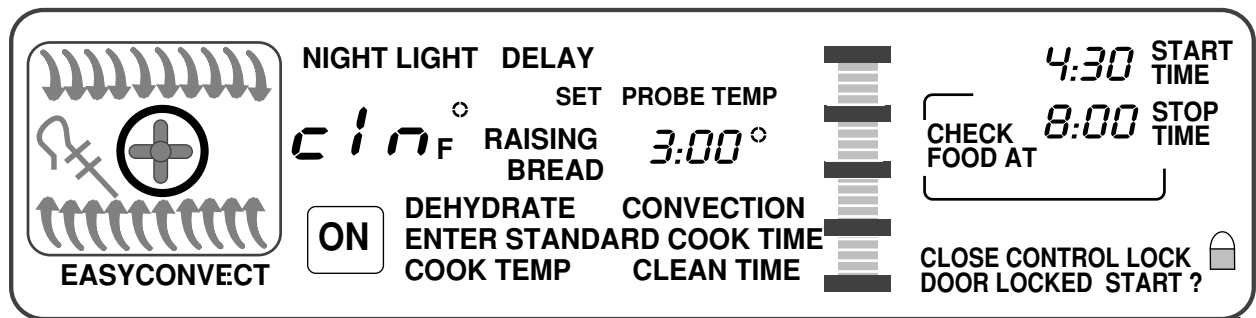

After 30-minutes:

- The Bake Ignitor is ON.
- The Bake Valve is ON.
- The Broil Circuit is OFF.

KitchenAid Electronic Range Controls “Clean Mode”

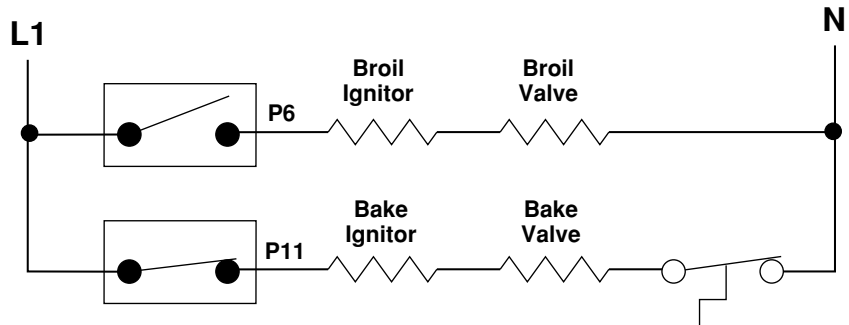
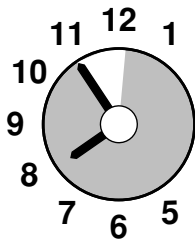
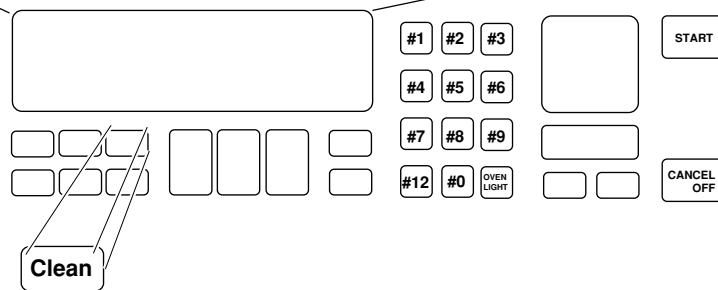
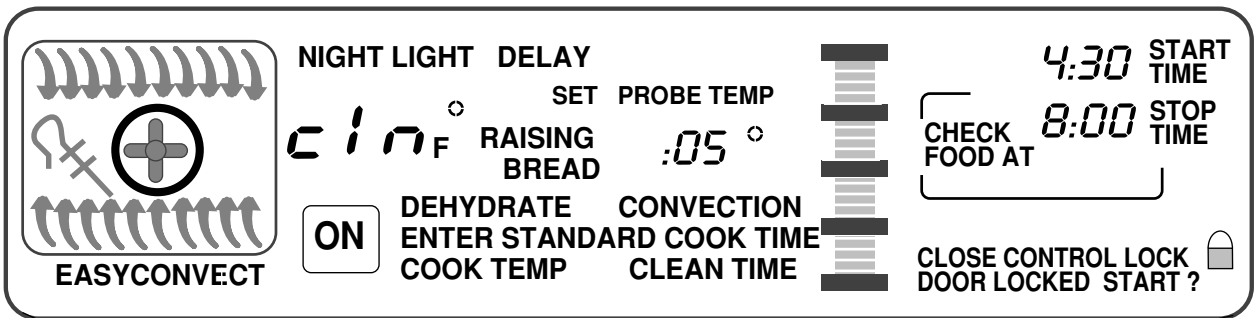

After approximately 3-hours:

- The display shows that the clean time remaining is 5-minutes.

KitchenAid Electronic Range Controls

“Clean Mode”

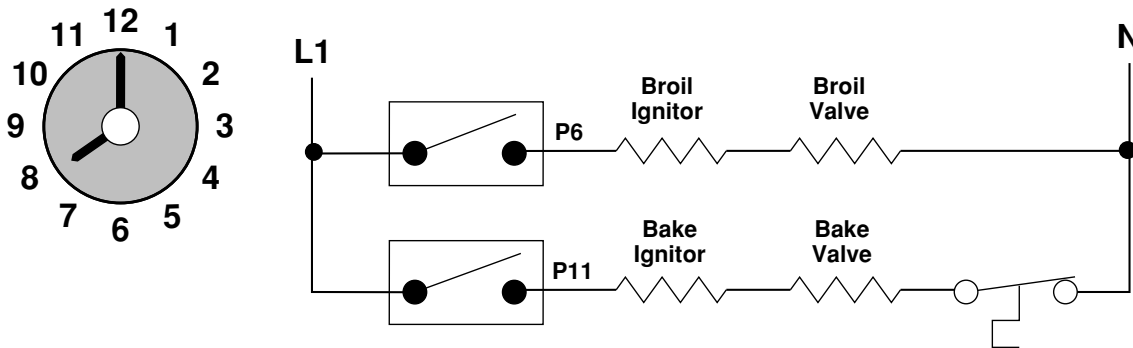
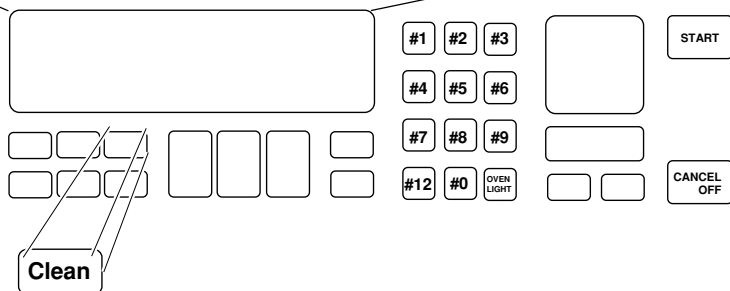
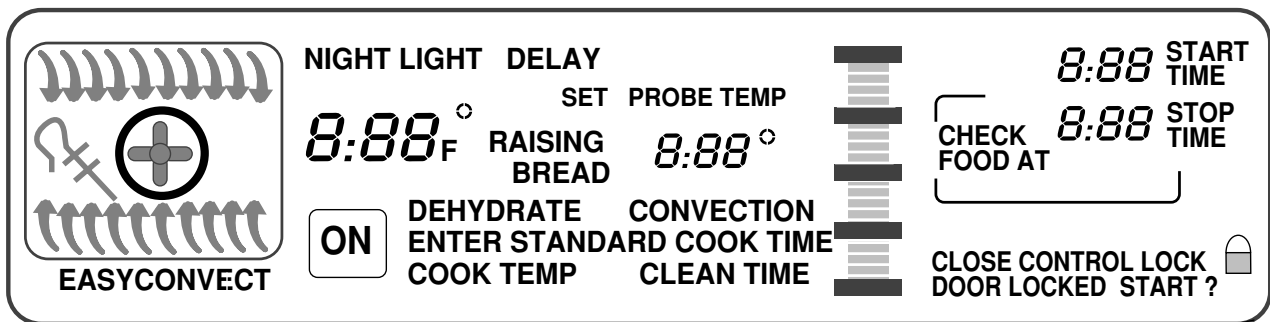

When the Clean Cycle ends:

- The oven door will remain locked.
- The display will show “locked” for as long as the oven is hot.

KitchenAid Electronic Range Controls “Clean Mode”

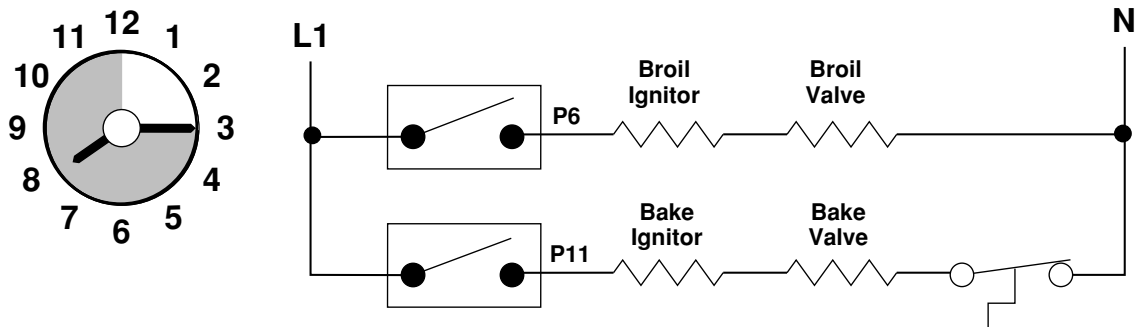
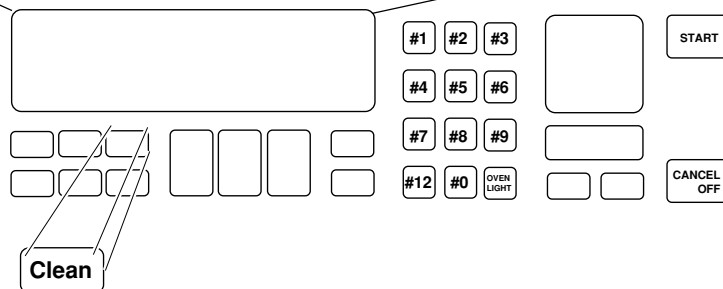
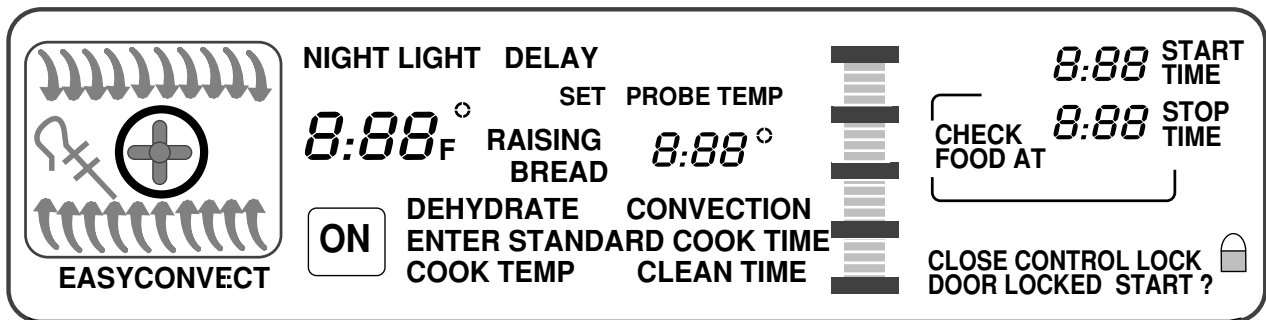

When the Clean Cycle ends:

- The oven door will remain locked.
- The display will show “locked” for as long as the oven is hot.

KitchenAid Electronic Range Controls

“Clean Mode”

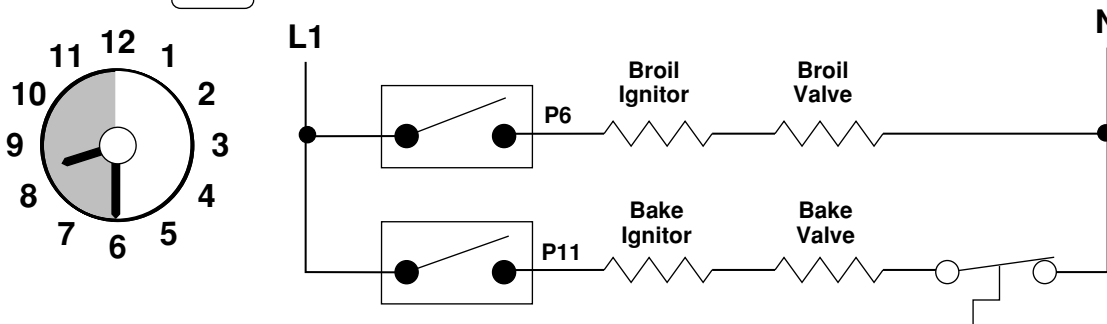
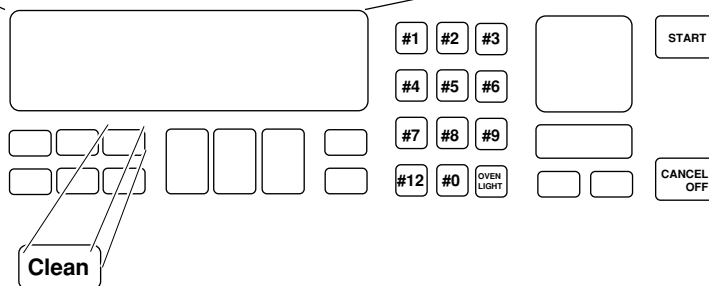
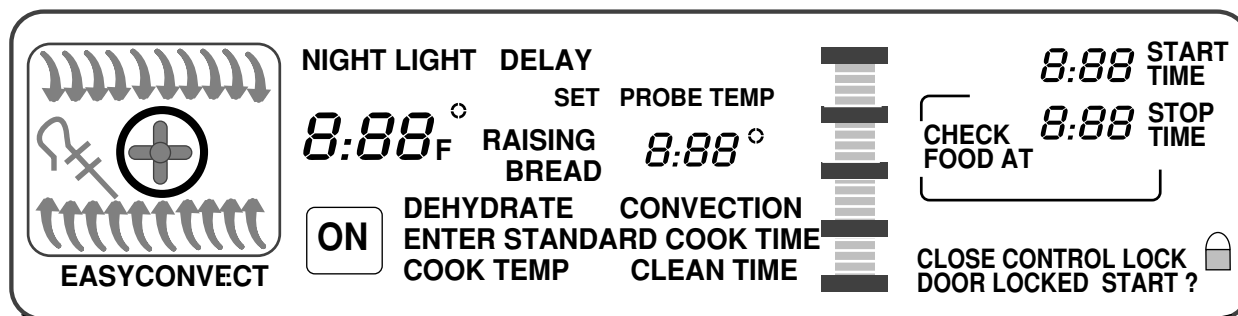

When the Clean Cycle ends:

- The oven door will remain locked.
- The display will show “locked” for as long as the oven is hot.

KitchenAid Electronic Range Controls

“Clean Mode”

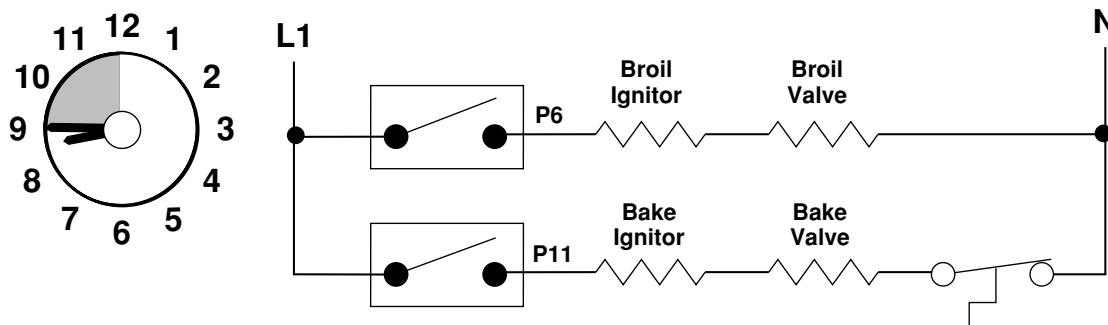
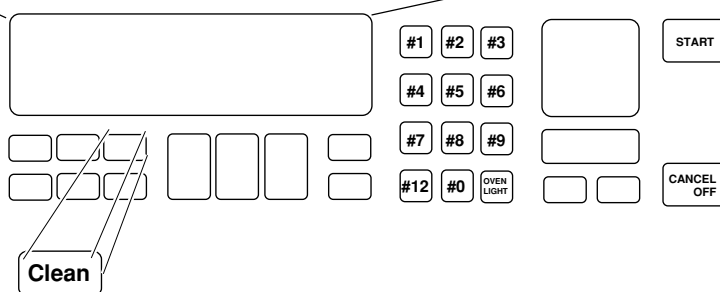
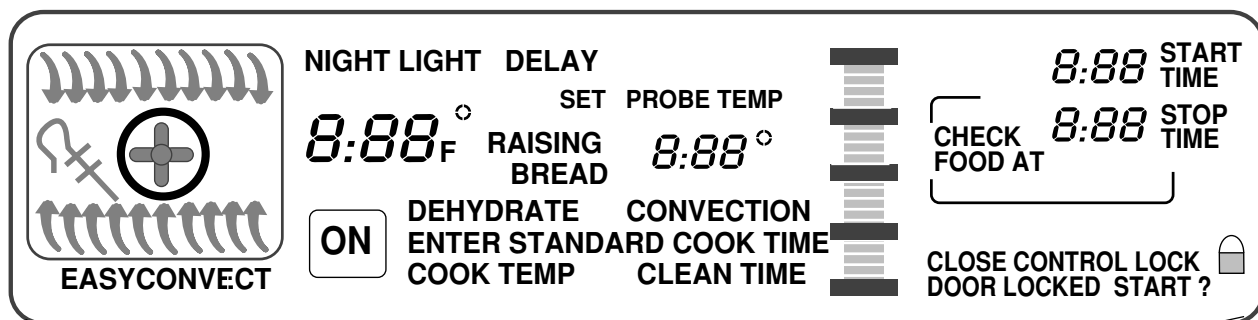

After approximately 45-minutes:

- The oven door will unlock.
- The oven door “locked” display will turn off when the oven temperature is below 600°F.

KitchenAid Electronic Range Controls

“B” Line Freestanding/Slide-In

“D” Line Built-In Wall Ovens

Things to Remember:

- **Replacement service controls must be programmed to meet the range configuration that they are being used in. Failure to do so will result in an F-code.**

QUESTIONS