

KitchenAid

TECHNICAL EDUCATION

27" & 30" ELECTRIC BUILT-IN DOUBLE OVEN



MODELS: KEBK276S*, KEBK206S*, KEBS277S*
KEBS207S*, KEBS278S*, KEBS208S*

JOB AID 4317416

FORWARD

This Kitchen Aid Job Aid “27” & 30” Electric Built-In Double Oven” (Part No. 4317416), provides the In-Home Service Professional with information on the installation, operation, and service of the 27” & 30” Electric Built-In Double Oven. For specific information on the model being serviced, refer to the “Use and Care Guide,” or “Tech Sheet” provided with the oven.

The Wiring Diagram and Strip Circuits used in this Job Aid are typical and should be used for training purposes only. Always use the Wiring Diagram supplied with the product when servicing the oven.

GOALS AND OBJECTIVES

The goal of this Job Aid is to provide information that will enable the In-Home Service Professional to properly diagnose malfunctions and repair the 27” & 30” Electric Built-In Double Oven.

The objectives of this Job Aid are to:

- Understand and follow proper safety precautions.
- Successfully troubleshoot and diagnose malfunctions.
- Successfully perform necessary repairs.
- Successfully return the oven to its proper operational status.

WHIRLPOOL CORPORATION assumes no responsibility for any repairs made on our products by anyone other than authorized In-Home Service Professionals.

TABLE OF CONTENTS

Page

GENERAL	1-1
Oven Safety	1-1
Model & Serial Number Designations	1-2
Model & Serial Number Label And Tech Sheet Locations.....	1-3
Specifications	1-4
INSTALLATION INFORMATION	2-1
Installation Requirements.....	2-1
Installation Instructions.....	2-4
PRODUCT OPERATION	3-1
COMPONENT ACCESS	4-1
Component Locations	4-1
<i>Upper Oven Components</i>	4-1
Removing The Keypad And User Interface Board	4-2
Removing The Oven Appliance Manager	4-3
Removing The Oven Light Transformer	4-5
Removing The AC Terminal Block.....	4-6
Removing The Upper Door Latch Assembly	4-7
Removing The Upper Broil Element And The Upper Oven Temperature Sensor	4-10
Removing The Upper Convection Ring Element and Convection Fan Motor	4-12
Removing The Upper Halogen Light Assembly And Meat Probe Jack	4-14
Removing The Upper Blower Assembly, Blower, Speed Resistor, And Thermal Cutoff... ..	4-16
Removing The Upper Hidden Bake Element	4-18
Removing Upper Oven Door Glass and Handle	4-20
Removing Upper Oven Door Gasket	4-22
<i>Lower Oven Components</i>	4-23
Removing The Lower Door Latch Assembly	4-24
Removing The Lower Broil Element And The Lower Oven Temperature Sensor	4-27
Removing The Lower Convection Ring Element And Convection Fan Motor	4-29
Removing Lower Halogen Light Assembly And Meat Probe Jack	4-31
Removing Lower Blower Assembly, Blower Seed Resistor, And Oven Thermal Cutoff	4-33
Removing The Lower Hidden Bake Element	4-35
Removing Lower Oven Door Glass And Handle	4-37
Removing Lower Oven Door Gasket	4-38

	Page
COMPONENT TESTING	5-1
UPPER OVEN COMPONENTS	5-1
Blower Motor	5-1
Oven Temperature Sensor	5-1
Convection Ring Element	5-2
Convection Fan Motor	5-2
Broil Element	5-3
Hidden Bake Element.....	5-3
Door Latch Assembly.....	5-4
Oven Shutdown Thermal Cutoff (TCO)	5-5
Oven Light Transformer.....	5-5
Meat Probe Jack.....	5-6
Blower Speed Resistor	5-6
LOWER OVEN COMPONENTS	5-7
Door Latch Assembly.....	5-7
Broil Element	5-8
Oven Temperature Sensor	5-8
Convection Ring Element	5-9
Convection Fan Motor	5-9
Meat Probe Jack.....	5-10
Blower Motor	5-10
Blower Speed Resistor	5-11
Oven Shutdown Thermal Cutoff (TCO)	5-11
Hidden Bake Element.....	5-12
DIAGNOSTICS & TROUBLESHOOTING	6-1
Diagnostics.....	6-1
Failure/Error Display Codes	6-2
Fahrenheit To Celsius Conversion	6-6
Adjust Oven Temperature Calibration	6-6
Programming The Cavity Size	6-6
Keypads	6-7
Relay Logic - Upper And Lower Oven.....	6-7
WIRING DIAGRAM & STRIP CIRCUITS	7-1
Wiring Diagram	7-1
Strip Circuits.....	7-2

GENERAL OVEN SAFETY

Your safety and the safety of others are very important.

We have provided many important safety messages in this manual and on the appliance. Always read and obey all safety messages.



This is the safety alert symbol.

This symbol alerts you to potential hazards that can kill or hurt you and others.

All safety messages will follow the safety alert symbol and either the word “DANGER” or “WARNING.” These words mean:

! DANGER

You can be killed or seriously injured if you don't immediately follow instructions.

! WARNING

You can be killed or seriously injured if you don't follow instructions.

All safety messages will tell you what the potential hazard is, tell you how to reduce the chance of injury, and tell you what can happen if the instructions are not followed.

WHIRLPOOL MODEL & SERIAL NUMBER DESIGNATIONS

MODEL NUMBER

MODEL NUMBER	K	EB	S	20	8	S	SS	0
PRODUCT GROUP K = KITCHENAID								
PRODUCT IDENTIFICATION EB = ELECTRIC BUILT-IN OVEN EH = ELECTRIC BUILT-IN HI SPEED COMBO EM = ELECTRIC BUILT-IN MICRO COMBO EW = ELECTRIC WARMING OVEN/DRAWER GB = GAS BUILT-IN OVEN GM = GAS BUILT-IN MICRO COMBO OVEN								
MERCHANDISING SCHEME A = ARCHITECT C = FLUSH LOOK D = DRAWER I = IMPERIAL N = INTERNATIONAL COLLECTION EUROPEAN S = SUPERBA V = VBL PRO LINE SERIES								
CAPACITY / SIZE / SERIES / CONFIGURATION 1ST POSITION 2ND POSITION 1 = SINGLE OVEN 4 = 24" WIDE 2 = DOUBLE OVEN 6 = 36" WIDE 3 = COMBO OVEN 7 = 27" WIDE 5 = MINI OVEN 0 = 30" WIDE 6 = COMBO W/MINI OVEN								
FEATURE CODE 0 = STANDARD FEATURES 1 = STANDARD FEATURES / ELEC COOK 2 = INDOOR / OUTDOOR FEATURES 5 = DELUXE FEATURES 6 = DELUXE FEATURES / ELEC. CLOCK 9 = MULTI-MODE								
YEAR OF INTRODUCTION S = 2006 T = 2007								
COLOR CODE SS = STAINLESS STEEL BL = BLACK WH = WHITE								
ENGINEERING CHANGE (0, 1, 2, ETC.)								

SERIAL NUMBER

SERIAL NUMBER	X	T	41	01002
DIVISION RESPONSIBILITY X = OXFORD				
YEAR OF PRODUCTION T = 2006 U = 2007				
WEEK OF PRODUCTION 41 = 41ST WEEK				
PRODUCT SEQUENCE NUMBER				

MODEL & SERIAL NUMBER LABEL AND TECH SHEET LOCATIONS

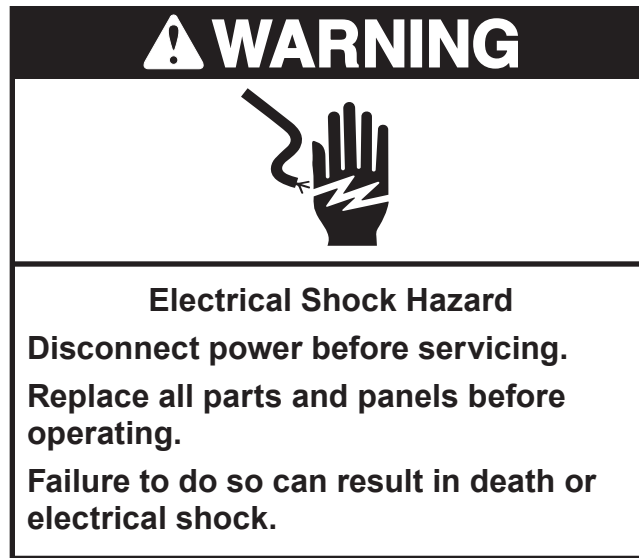

The Model/Serial Number label and Tech Sheet locations are shown below.

**Tech Sheet Location
(Under Top Cover)**



**Model & Serial Number
Label Location**

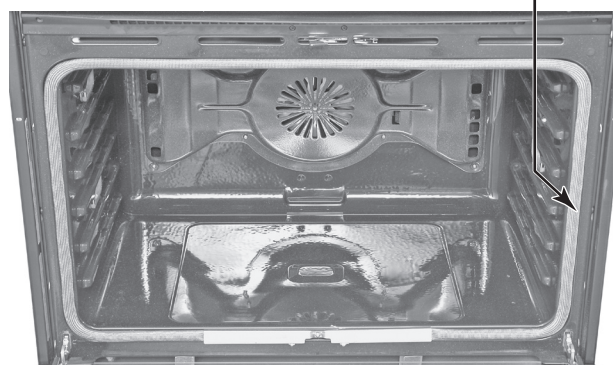

SPECIFICATIONS

Model Number	KEBK276SSS, BL, WH	KEBK206SSS, BL, WH
Model Description	Double Built-In Oven	Double Built-In Oven
Size - Configuration	27"	30"
Feature Level/Series	KitchenAid	KitchenAid
Predecessor Model (Model This Model Replaces)	KEBC276K	KEBC206K
Dimensions		
Exterior Dimensions		
Overall Height	50 3/4"	50 3/4"
Overall Width	26-3/4"	29-3/4"
Overall Depth (Includes Hdw/Handle)	26"	26"
Depth w/Door Open 90°	43-3/4"	43-3/4"
Door Swing	15-3/8"	15-3/8"
Cutout Dimensions		
Cutout Height (Measure or Min/Max)	49 3/4"	49 3/4"
Cutout Width (Measure or Min/Max)	25-1/2"	28-1/2"
Cutout Depth (Measure or Min/Max)	23-1/4"	23-1/4"
Other Dimensions		
Conduit Size (Length/Diameter)	66" / 1/2"	66" / 1/2"
Ratings		
Electric Voltage/Phase/Frequency (Hz)	208V / 240V / 2-3 / 60	208V / 240V / 2-3 / 60
Total Connected Load in kW		
240 Volts	10.50	10.50
208 Volts	7.88	7.88
240/120V AC	10.63	10.63
Circuit Amps	40	40
Interior		
Upper Oven		
Cooking System	Standard Thermal	Standard Thermal
Cleaning System	Self Cleaning	Self Cleaning
Upper Oven Liner Finish	Blue Porcelain	Blue Porcelain
Upper Oven Dimensions		
Upper Oven Volume (cu ft)	3.6	4.1
Upper Oven Height	16"	16"
Upper Oven Width	22"	25"
Upper Oven Depth	17-5/8"	17-5/8"
Oven Light #/Location	3 Side Halogen	3 Side Halogen
Upper Oven		
Hidden Bake Element	Yes	Yes
Electric Element Output		
Bake (w@240/208)	2000 Watt	2000 Watt
Broil Inner Element (w@240/208)	1800 Watt	1800 Watt
Broil Outer Element (w@240/208)	1450 Watt	1450 Watt

Model Number	KEBK276SSS, BL, WH	KEBK206SSS, BL, WH
Lower Oven		
Cooking System	Standard Thermal	Standard Thermal
Cleaning System	Self Cleaning	Self Cleaning
Lower Oven Liner Finish	Blue Porcelain	Blue Porcelain
Lower Oven Dimensions		
Lower Oven Volume (cu ft)	3.6	4.1
Lower Oven Height	16"	16"
Lower Oven Width	22"	25"
Lower Oven Depth	17-5/8"	17-5/8"
Oven Light #/Location	3 Side Halogen	3 Side Halogen
Lower Oven		
Hidden Bake Element	Yes	Yes
Electric Element Output		
Bake (w@240/208)	2000 Watt	2000 Watt
Broil Inner Element (w@240/208)	1800 Watt	1800 Watt
Broil Outer Element (w@240/208)	1450 Watt	1450 Watt
Miscellaneous		
Product Literature		
Installation Instructions Part #	8304336	8304336
Service Manual Part #	4317416	4317416
Tech Sheet Part #	8303952 (E) 8304416 (F)	8303952 (E) 8304416 (F)
Under Counter Capability	No	No
Agency Approvals	UL, CUL	UL, CUL
Installation Hardware	Yes	Yes
Warranty		
Limited	12 Mo.	12 Mo.
Extended		
Electronic Controls	60 Mo. Parts Only	60 Mo. Parts Only
Electrical Elements	60 Mo. Parts Only	60 Mo. Parts Only

SPECIFICATIONS

Model Number	KEBS277SSS, BL, BT, WH	KEBS207SSS, BL, BT, WH
Model Description	Double Built-In Oven	Double Built-In Oven
Size - Configuration	27"	30"
Feature Level/Series	Superba	Superba
Predecessor Model (Model This Model Replaces)	KEBC277K	KEBC207K
Dimensions		
Exterior Dimensions		
Overall Height	50 3/4"	50 3/4"
Overall Width	26-3/4"	29-3/4"
Overall Depth (Includes Hdw/Handle)	26"	26"
Depth w/Door Open 90°	43-3/4"	43-3/4"
Door Swing	15-3/8"	15-3/8"
Cutout Dimensions		
Cutout Height (Measure or Min/Max)	49 3/4"	49 3/4"
Cutout Width (Measure or Min/Max)	25-1/2"	28-1/2"
Cutout Depth (Measure or Min/Max)	23-1/4"	23-1/4"
Other Dimensions		
Conduit Size (Length/Diameter)	66" / 1/2"	66" / 1/2"
Ratings		
Electric Voltage/Phase/Frequency (Hz)	208V / 240V / 2-3 / 60	208V / 240V / 2-3 / 60
Total Connected Load in kW		
240 Volts	12.10	12.10
208 Volts	9.08	9.08
240/120V AC	12.27	12.27
Circuit Amps	40	40
Interior		
Upper Oven		
Cooking System	Bow-Tie Convection	Bow-Tie Convection
Cleaning System	Self Cleaning	Self Cleaning
Upper Oven Liner Finish	Blue Porcelain	Blue Porcelain
Upper Oven Dimensions		
Upper Oven Volume (cu ft)	3.6	4.1
Upper Oven Height	16"	16"
Upper Oven Width	22"	25"
Upper Oven Depth	17-5/8"	17-5/8"
Oven Light #/Location	3 Side Halogen	3 Side Halogen
Upper Oven		
Hidden Bake Element	Yes	Yes
Electric Element Output		
Bake (w@240/208)	2000 Watt	2000 Watt
Broil Inner Element (w@240/208)	1800 Watt	1800 Watt
Broil Outer Element (w@240/208)	1450 Watt	1450 Watt
Convection (w@240/208)	1600 Watt	1600 Watt

Model Number	KEBS277SSS, BL, BT, WH	KEBS207SSS, BL, BT, WH
Lower Oven		
Cooking System	Standard Thermal	Standard Thermal
Cleaning System	Self Cleaning	Self Cleaning
Lower Oven Liner Finish	Blue Porcelain	Blue Porcelain
Lower Oven Dimensions		
Lower Oven Volume (cu ft)	3.6	4.1
Lower Oven Height	16"	16"
Lower Oven Width	22"	25"
Lower Oven Depth	17-5/8"	17-5/8"
Oven Light #/Location	3 Side Halogen	3 Side Halogen
Lower Oven		
Hidden Bake Element	Yes	Yes
Electric Element Output		
Bake (w@240/208)	2000 Watt	2000 Watt
Broil Inner Element (w@240/208)	1800 Watt	1800 Watt
Broil Outer Element (w@240/208)	1450 Watt	1450 Watt
Miscellaneous		
Product Literature		
Installation Instructions Part #	8304336	8304336
Service Manual Part #	4317416	4317416
Tech Sheet Part #	8303952 (E) 8304416 (F)	8303952 (E) 8304416 (F)
Under Counter Capability	No	No
Agency Approvals	UL, CUL	UL, CUL
Installation Hardware	Yes	Yes
Warranty		
Limited	12 Mo.	12 Mo.
Extended		
Electronic Controls	60 Mo. Parts Only	60 Mo. Parts Only
Electrical Elements	60 Mo. Parts Only	60 Mo. Parts Only

SPECIFICATIONS

Model Number	KEBS278SSS, BL, BT, WH	KEBS208SSS, BL, BT, WH
Model Description	Double Built-In Oven	Double Built-In Oven
Size - Configuration	27"	30"
Feature Level/Series	Superba	Superba
Predecessor Model (Model This Model Replaces)	KEBC278K	KEBC208K
Dimensions		
Exterior Dimensions		
Overall Height	50 3/4"	50 3/4"
Overall Width	26-3/4"	29-3/4"
Overall Depth (Includes Hdw/Handle)	26"	26"
Depth w/Door Open 90°	43-3/4"	43-3/4"
Door Swing	15-3/8"	15-3/8"
Cutout Dimensions		
Cutout Height (Measure or Min/Max)	49 3/4"	49 3/4"
Cutout Width (Measure or Min/Max)	25-1/2"	28-1/2"
Cutout Depth (Measure or Min/Max)	23-1/4"	23-1/4"
Other Dimensions		
Conduit Size (Length/Diameter)	66" / 1/2"	66" / 1/2"
Ratings		
Electric Voltage/Phase/Frequency (Hz)	208V / 240V / 2-3 / 60	208V / 240V / 2-3 / 60
Total Connected Load in kW		
240 Volts	13.70	13.70
208 Volts	10.28	10.28
240/120V AC	13.91	13.91
Circuit Amps	40	40
Interior		
Upper Oven		
Cooking System	Bow-Tie Convection	Bow-Tie Convection
Cleaning System	Self Cleaning	Self Cleaning
Upper Oven Liner Finish	Blue Porcelain	Blue Porcelain
Upper Oven Dimensions		
Upper Oven Volume (cu ft)	3.6	4.1
Upper Oven Height	16"	16"
Upper Oven Width	22"	25"
Upper Oven Depth	17-5/8"	17-5/8"
Oven Light #/Location	3 Side Halogen	3 Side Halogen
Upper Oven		
Hidden Bake Element	Yes	Yes
Electric Element Output		
Bake (w@240/208)	2000 Watt	2000 Watt
Broil Inner Element (w@240/208)	1800 Watt	1800 Watt
Broil Outer Element (w@240/208)	1450 Watt	1450 Watt
Convection (w@240/208)	1600 Watt	1600 Watt

Model Number	KEBS278SSS, BL, BT, WH	KEBS208SSS, BL, BT, WH
Lower Oven		
Cooking System	Standard Thermal	Standard Thermal
Cleaning System	Self Cleaning	Self Cleaning
Lower Oven Liner Finish	Blue Porcelain	Blue Porcelain
Lower Oven Dimensions		
Lower Oven Volume (cu ft)	3.6	4.1
Lower Oven Height	16"	16"
Lower Oven Width	22"	25"
Lower Oven Depth	17-5/8"	17-5/8"
Oven Light #/Location	3 Side Halogen	3 Side Halogen
Lower Oven		
Hidden Bake Element	Yes	Yes
Electric Element Output		
Bake (w@240/208)	2000 Watt	2000 Watt
Broil Inner Element (w@240/208)	1800 Watt	1800 Watt
Broil Outer Element (w@240/208)	1450 Watt	1450 Watt
Lower Convection (w@240/208)	1600 Watt	1600 Watt
Miscellaneous		
Product Literature		
Installation Instructions Part #	8304336	8304336
Service Manual Part #	4317416	4317416
Tech Sheet Part #	8303952 (E) 8304416 (F)	8303952 (E) 8304416 (F)
Under Counter Capability	No	No
Agency Approvals	UL, CUL	UL, CUL
Installation Hardware	Yes	Yes
Warranty		
Limited	12 Mo.	12 Mo.
Extended		
Electronic Controls	60 Mo. Parts Only	60 Mo. Parts Only
Electrical Elements	60 Mo. Parts Only	60 Mo. Parts Only

— NOTES —

INSTALLATION INFORMATION

INSTALLATION REQUIREMENTS

TOOLS AND PARTS

Gather the required tools and parts before starting installation. Read and follow the instructions provided with any tools listed here.

Tools needed

- Phillips screwdriver
- Measuring tape
- Hand or electric drill (for wall cabinet installations)
- 1" (25 mm) drill bit (for wall cabinet installations)
- Level

Parts needed

- UL listed or CSA approved conduit connector
- UL listed wire connectors

Parts supplied

- # 8-14 x 1" screws - single oven (2), double oven (4)
- Bottom vent (supplied on some models)
- Two # 8-18 x 3/8" screws - bottom vent (supplied on some models)

Check local codes. Check existing electrical supply. See "Electrical Requirements," page 2-2. It is recommended that all electrical connections be made by a licensed, qualified electrical installer.

LOCATION REQUIREMENTS

Make sure you have everything needed for correct installation. It is the responsibility of the installer to comply with the installation clearances specified in these instructions.

IMPORTANT: Observe all governing codes and ordinances.

- Cabinet opening dimensions that are shown must be used. Given dimensions provide minimum clearance with oven.

- Recessed installation area must provide complete enclosure around the recessed portion of the oven.
- Grounded electrical supply is required. See "Electrical Requirements," page 2-2.
- Electrical supply junction box should be located 3" (7.6 cm) maximum below the support surface when the oven is installed in a wall cabinet. A 1" (2.5 cm) minimum diameter hole should have been drilled in the right rear or left rear corner of the support surface to pass the appliance cable through to the junction box.
- Oven support surface must be solid, level and flush with bottom of cabinet cutout. Floor must be able to support a total weight (double built-in oven) of 287 lbs (108 kg).

Product Dimensions

27" (68.6 cm) and 30" (76.2 cm) Ovens

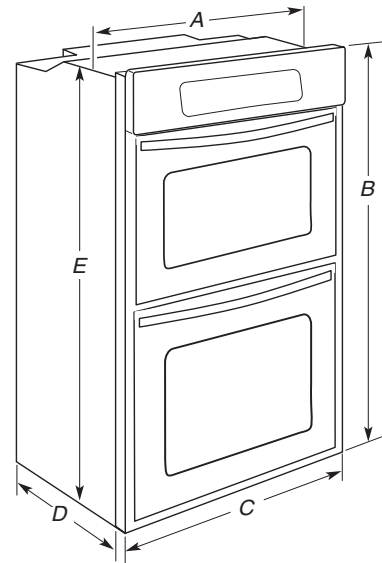

27" (68.6 cm) models

A. 25 5/16" (64.3 cm) max. recessed width

B. 50 3/4" (128.9 cm) max. overall height

C. 26 3/4" (67.9 cm) overall width

D. 23" (58.4 cm) max. recessed depth

E. 49 9/16" (125.9 cm) recessed height

30" (76.2 cm) models

A. 28 5/16" (71.9 cm) max. recessed width

B. 50 3/4" (128.9 cm) max. overall height

C. 29 3/4" (75.6 cm) overall width

D. 23" (58.4 cm) max. recessed depth

E. 49 9/16" (125.9 cm) recessed height

Cabinet Dimensions

27" (68.6 cm) and 30" (76.2 cm) Ovens

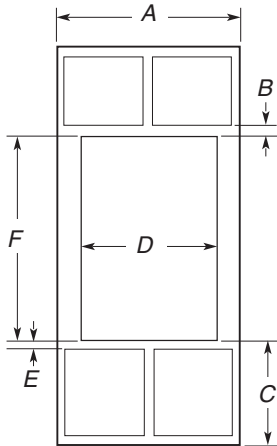

27" (68.6 cm) models

- A. 27" (68.6 cm) min. cabinet width
- B. 1" (2.5 cm) top of cutout to bottom of upper cabinet door
- C. 14 3/4" (37.5 cm) bottom of cutout to floor
- D. 25 1/2" (64.8 cm) cutout width
- E. 1 1/2" (3.8 cm) min. bottom of cutout to top of cabinet door
- F. 49 3/4" (126.4 cm) min. cutout height

30" (76.2 cm) models

- A. 30" (76.2 cm) min. cabinet width
- B. 1" (2.5 cm) top of cutout to bottom of upper cabinet door
- C. 14 3/4" (37.5 cm) bottom of cutout to floor
- D. 28 1/2" (72.4 cm) cutout width
- E. 1 1/2" (3.8 cm) min. bottom of cutout to top of cabinet door
- F. 49 3/4" (126.4 cm) min. cutout height

Cabinet Side View

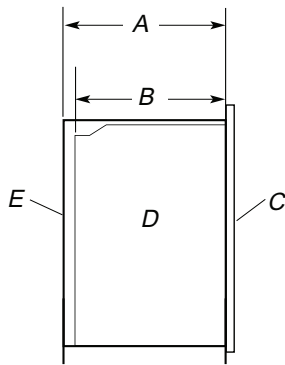

- A. 23-1/4" (59.1 cm) min. cutout depth
- B. 23" (58.4 cm) recessed oven depth
- C. Oven front
- D. Recessed oven
- E. Cabinet

ELECTRICAL REQUIREMENTS

If codes permit and a separate ground wire is used, it is recommended that a qualified electrical installer determine that the ground path and wire gauge are in accordance with local codes.

Check with a qualified electrical installer if you are not sure the oven is properly grounded.

This oven must be connected to a grounded metal, permanent wiring system.

Be sure that the electrical connection and wire size are adequate and in conformance with the National Electrical Code, ANSI/NFPA 70-latest edition or CSA Standards C22.1-94, Canadian Electrical Code, Part 1 and C22.2 No. O-M91-latest edition, and all local codes and ordinances.

A copy of the above code standards can be obtained from:

National Fire Protection Association
 One Batterymarch Park
 Quincy, MA 02269
 CSA International
 8501 East Pleasant Valley Road
 Cleveland, OH 44131-5575

Electrical Connection

To properly install your oven, you must determine the type of electrical connection you will be using and follow the instructions provided for it here.

- Oven must be connected to the proper electrical voltage and frequency as specified on the model/serial number rating plate. The model/serial number rating plate is located at the bottom of the right-hand mounting rail. See the following illustration.

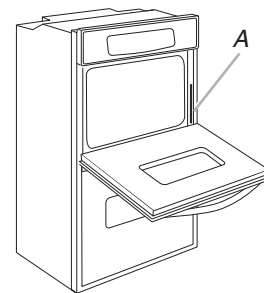

Double Oven
 A. Model/serial number plate

- Models rated from 7.3 to 9.6 kW at 240 volts (5.5 to 7.2 kW at 208 volts) require a separate 40-amp circuit. Models rated at 7.2 kW and below at 240 volts (5.4 kW and below at 208 volts) require a separate 30-amp circuit.
 - A time-delay fuse or circuit breaker is recommended.
 - Connect directly to the fused disconnect (or circuit breaker box) through flexible, armored or nonmetallic sheathed, copper cable (with grounding wire). See “Make Electrical Connection,” page 2-5.
 - Flexible cable from the oven should be connected directly to the junction box.
 - Fuse both sides of the line.
- Do not cut the conduit. The length of conduit provided is for serviceability of the oven.
 - A UL listed or CSA approved conduit connector must be provided.
 - If the house has aluminum wiring follow the procedure below:
 1. Connect a section of solid copper wire to the pigtail leads.
 2. Connect the aluminum wiring to the added section of copper wire using special connectors and/or tools designed and UL listed for joining copper to aluminum.
- Follow the electrical connector manufacturer’s recommended procedure. Aluminum/copper connection must conform with local codes and industry accepted wiring practices.

INSTALLATION INSTRUCTIONS

PREPARE BUILT-IN DOUBLE OVEN

1. Decide on the final location for the oven. Locate existing wiring to avoid drilling into or severing wiring during installation.

⚠ WARNING

Excessive Weight Hazard

Use two or more people to move and install oven.

Failure to do so can result in back or other injury.

2. To avoid floor damage, set the oven onto cardboard prior to installation. Do not use handle or any portion of the front frame for lifting.
3. Remove the shipping materials and tape from the oven.
4. Remove the hardware package from inside the bag containing literature.
5. Remove and set aside racks and other parts from inside the oven.
6. Move oven and cardboard close to the oven's final location.

REMOVE OVEN DOOR

IMPORTANT: Use both hands to remove oven door.

1. Open the oven door.
2. Locate the oven door latches in both corners of the oven door, and rotate the latches forward to the unlocked position.

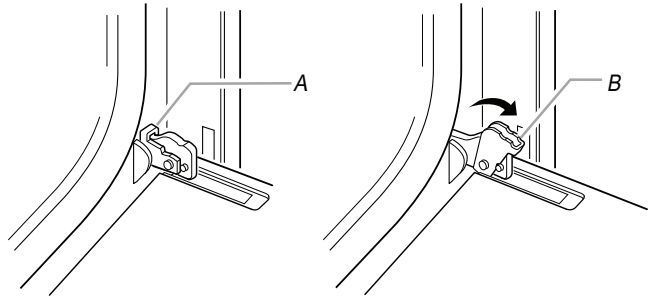

A. Oven door latch in locked position

B. Oven door latch in unlocked position

3. Grasp the edges of the oven door with both hands and close the oven door until it will no longer close. Lift and pull oven door toward you and remove. Set the oven door aside on a covered work surface.

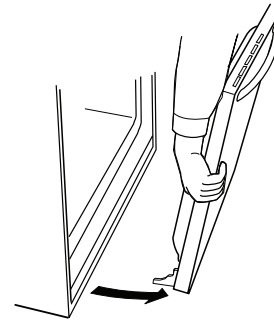

MAKE ELECTRICAL CONNECTION

! WARNING



Electrical Shock Hazard
Disconnect power before servicing.
Use 8 gauge solid copper wire.
Electrically ground oven.
Failure to follow these instructions can result in death, fire, or electrical shock.

This oven is manufactured with a neutral (white) power supply wire and a cabinet-connected green (or bare) ground wire twisted together.

1. Disconnect power.
2. Feed the flexible cable conduit from the oven through the opening in the cabinet.
3. Remove junction box cover if it is present.
4. Install a UL listed or CSA approved conduit connector to the junction box.

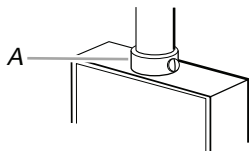

A. UL listed or CSA approved conduit connector

5. Route the flexible cable conduit from the oven to the junction box through a UL listed or CSA approved conduit connector.
6. Tighten screws on conduit connector.
7. See "Electrical Connection Options Chart" to complete installation for your type of electrical connection.

Electrical Connection Options Chart

If your home has:

Go to section:

4-wire

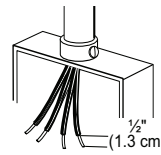

4-wire Cable from Home Power Supply

3-wire

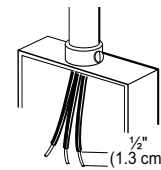

3-wire Cable from Home Power Supply

4-Wire Cable from Home Power Supply

IMPORTANT: Use the 4-wire cable from home power supply in the U.S. where local codes do not allow grounding through neutral, New Branch circuit installations (1996 NEC), mobile homes and recreational vehicles, new construction and in Canada.

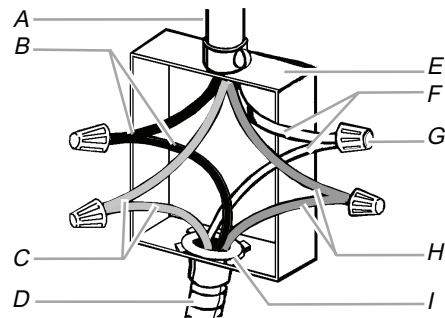

- | | |
|------------------------------------|--|
| A. Cable from home power supply | F. White wires |
| B. Black wires | G. UL listed wire connectors |
| C. Red wires | H. Green (or bare) ground wires |
| D. 4-wire flexible cable from oven | I. UL listed or CSA approved conduit connector |
| E. Junction box | |

1. Connect the 2 black wires (B) together using a UL listed wire connector.
2. Connect the 2 red wires (C) together using a UL listed wire connector.
3. Untwist white wire from green (or bare) ground wire coming from the oven.
4. Connect the 2 white wires (F) together using a UL listed wire connector.
5. Connect the green (or bare) ground wire (H) from the oven cable to the green (or bare) ground wire (in the junction box) using a UL listed wire connector.
6. Install junction box cover.

3-Wire Cable from Home Power Supply - U.S. Only

IMPORTANT: Use the 3-wire cable from home power supply where local codes permit a 3-wire connection.

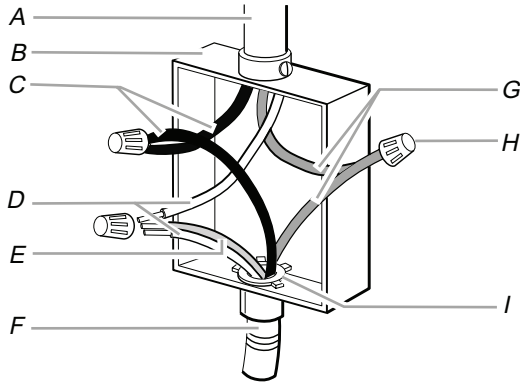

- | | |
|--|--|
| A. Cable from home power supply | F. 4-wire flexible cable from oven |
| B. Junction box | G. Red wires |
| C. Black wires | H. UL listed wire connectors |
| D. White wires | I. UL listed or CSA approved conduit connector |
| E. Green (or bare) ground wire (from oven) | |

1. Connect the 2 black wires (C) together using a UL listed wire connector.
2. Connect the 2 white wires (D) and the green (or bare) ground wire (of the oven cable) using a UL listed wire connector.
3. Connect the 2 red wires (G) together using a UL listed wire connector.
4. Install junction box cover.

INSTALL OVEN

! WARNING

Excessive Weight Hazard

Use two or more people to move and install oven.

Failure to do so can result in back or other injury.

1. Using 2 or more people, lift oven partially into cabinet cutout using the oven opening as an area to grip.

NOTE: Push against seal area of oven front frame when pushing oven into cabinet. Do not push against outside edges.

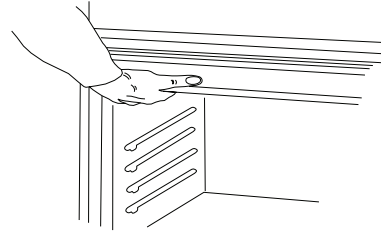

2. Push against seal area of front frame to push oven into cabinet.

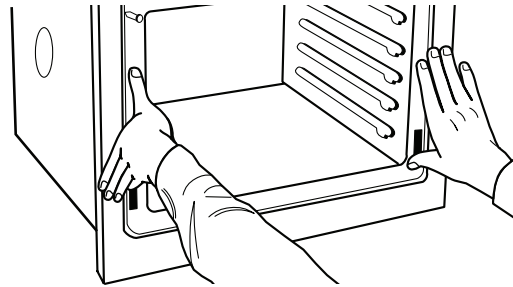

3. Push oven completely into cabinet and center oven into cabinet cutout.

- Securely fasten oven to cabinet using the #8-14 x 1" screws (2 for single oven, 4 for double oven) provided. Insert the screws through holes in mounting rails. Do not overtighten screws.

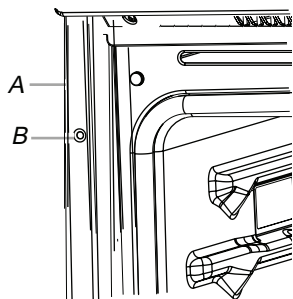

A. Mounting rail
B. Insert #8-14 x 1" screw.

- On some models, the oven vent is taped to the side of the oven.

With one #8-14 x 3/8" screw for each side of the vent, fasten vent securely to the oven.

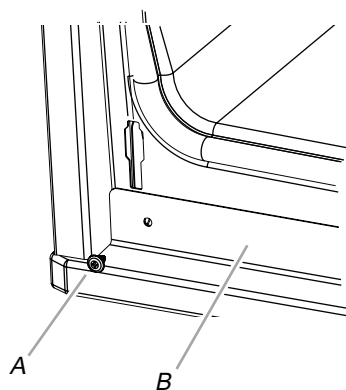

A. #8-14 x 3/8" screw
B. Oven vent

- Replace oven racks.
- Replace oven door by inserting ends of hinges into hinge slots in the oven frame.
- Push hinges in as far as they will go and open the oven door. You should feel the oven door drop into place.
- Rotate both hinge latches back to the locked position.

- Check that the door is free to open and close. If it is not, repeat the removal and installation procedures. See "Remove Oven Door," page 2-4.
- Reconnect power.
- Display panel will light briefly, and "PF" should appear in the display.
- If display panel does not light, please reference the "Assistance or Service" section of the Use and Care Guide or contact the dealer from whom you purchased your oven.

COMPLETE INSTALLATION

- Check that all parts are now installed. If there is an extra part, go back through the steps to see which step was skipped.
- Check that you have all of your tools.
- Dispose of/recycle all packaging materials.
- For oven use and cleaning, read the Use and Care Guide.

Check Operation of Lower Oven

- Turn power on.
- When "CLOCK ENTER TIME" appears in the lower oven display touch START.
- Touch LOWER OVEN to select the oven you are testing.
- Touch BROIL.
- Touch START.

If oven does not operate, check the following:

- Household fuse is intact and tight; or circuit breaker has not tripped.
 - Electrical supply is connected.
 - See "Troubleshooting" section in the Use and Care Guide.
- When oven has been on for 5 minutes, feel for heat. If you do not feel heat or if an error code ("F" followed by a number plus "E" followed by a number) appears in the display, turn off the oven and contact a qualified technician.
 - Touch LOWER OVEN OFF.

Check Operation of Upper Oven

1. Turn power on.
2. When “CLOCK ENTER TIME” appears in the lower oven display touch START.
3. Touch UPPER OVEN to select the oven you are testing.
4. Touch BROIL.
5. Touch START.

If oven does not operate, check the following:

- Household fuse is intact and tight; or circuit breaker has not tripped.
 - Electrical supply is connected.
 - See “Troubleshooting” section in the Use and Care Guide.
6. When oven has been on for 5 minutes, feel for heat. If you do not feel heat or if an error code (“F” followed by a number plus “E” followed by a number) appears in the display, turn off the oven and contact a qualified technician.
 7. Touch UPPER OVEN OFF.

If you need Assistance or Service:

Please reference the “Assistance or Service” section of the Use and Care Guide or contact the dealer from whom you purchased your built-in oven.

PRODUCT OPERATION

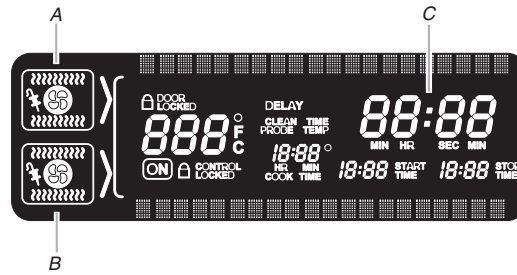

Double Oven Display
 A. Upper oven cavity symbol
 B. Lower oven cavity symbol
 C. Time of day, timer display

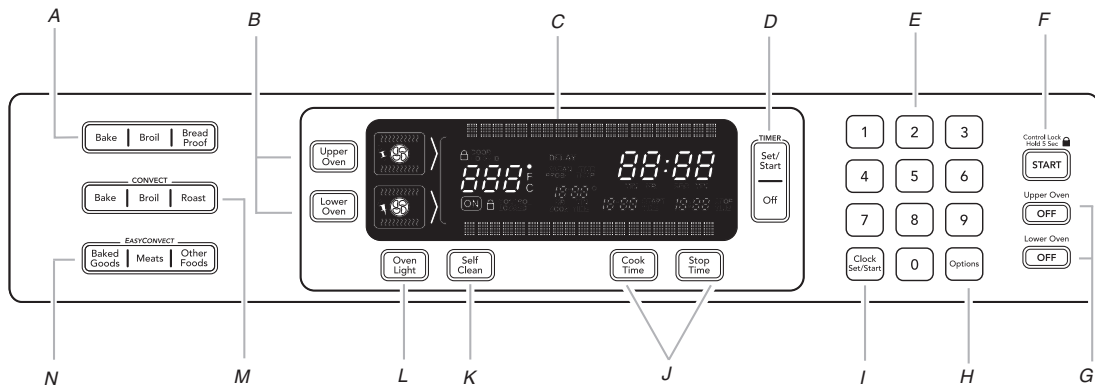

A. Oven settings
 B. Upper or lower oven selectors (double oven models only)
 C. Oven display
 D. Timer
 E. Number keys
 F. Start/control lock
 G. Upper and lower oven Off (double oven models) Off (single oven models)
 H. Options
 I. Clock set/start
 J. Timed cooking
 K. Self-clean
 L. Oven light
 M. Convection cooking settings
 N. EasyConvect™ conversion

ELECTRONIC OVEN CONTROL

CONTROL LOCK

The Control Lock shuts down the control panel keys to avoid unintended use of the oven. The Control Lock will remain set after a power failure, if set before the power failure occurs.

When the control is locked, only the TIMER SET/START, TIMER OFF and OVEN LIGHT keys will function.

The Control Lock is preset unlocked, but can be locked.

To Lock Control: Touch and hold START for approximately 5 seconds, until “control locked” appears on the lower text line and a lock icon appears in the display.

To Unlock Control: Repeat to unlock and remove “control locked” and lock icon from the display.

DEHYDRATING

(on convection models, closed door)

Dehydration is a method used to preserve food. Various factors, such as the quality of the fresh food, pretreatment techniques, the size and thickness of the food, and the climate may affect the finished product.

During dehydration, heat is used to force out moisture and air circulation is used to carry the moisture away.

Refer to a reliable book or source for complete information about dehydrating and preserving foods.

NOTE: The oven will automatically turn off after 12 hours. However, some foods may take more than 12 hours to dehydrate. If this is the case, the oven will need to be restarted.

SABBATH MODE

The Sabbath Mode sets the oven(s) to remain on in a bake setting until turned off. A timed Sabbath Mode can also be set to keep the oven on for only part of the Sabbath.

When the Sabbath Mode is set, only the number and start keys will function, no tones will sound, and the displays will not show messages or temperature changes. The heat sources icons will appear lit on the oven display throughout the Sabbath Mode.

When the oven door is opened or closed, the oven light will not turn on or off and the heating elements will not turn on or off immediately.

If a power failure occurs when the Sabbath Mode is set, the oven(s) will remain in Sabbath Mode but will no longer be actively cooking. The "ON" indicator will no longer be lit. Touch OFF to return to normal operating mode (non-Sabbath Mode, not cooking).

To Activate:

Before the Sabbath Mode can be regularly set, the oven(s) must first be enabled with a one time only setup. On double oven models, the following steps will enable both ovens.

1. On double ovens, open the upper or lower oven door. On single ovens, open the oven door.
2. On double ovens, touch UPPER OVEN OFF or LOWER OVEN OFF. On single ovens, touch OFF.
3. Touch the number keys 7, 8, 9, 6, in this order.
4. Touch START to activate. "SABBATH ENABLED" will appear on the display and remain for approximately 5 seconds. You may also touch OFF, UPPER OVEN OFF or LOWER OVEN OFF to clear the display.
5. Close oven door.

To Deactivate:

The oven(s) can be disabled of the ability to set the Sabbath Mode by repeating the previous steps. See the "To Activate" section. When disabled "SABBATH DISABLED" will appear on the display and remain on for approximately 5 seconds. The Sabbath Mode cannot be regularly set until re-enabled. On double oven models these steps will disable both ovens.

To Regularly Set, Untimed:

Sabbath Mode must be enabled before starting the Bake cycle.

See the "To Activate" section.

1. On double ovens only, touch UPPER OVEN or LOWER OVEN.
Each oven can be independently set.
2. Touch BAKE.
Touch the number keys to enter a temperature other than 350°F (177°C). The bake range can be set between 170°F and 500°F (77°C and 260°C).
3. Touch START.
4. Touch OPTIONS and then number key "7." "SABBATH MODE" will appear on the oven display.

CONVECTION BROIL

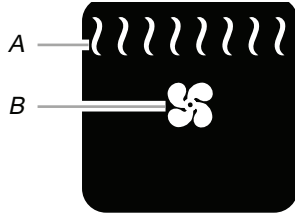

A. Broil heat
B. Convection fan

During convection broiling, the broil elements will cycle on and off in intervals to maintain oven temperature, while the fan constantly circulates the hot air.

The temperature is preset at 450°F (232°C), but can be changed to a different temperature. Cooking times will vary depending on the rack position and temperature and may need to be adjusted.

If the oven door is opened during convection broiling, fan turns off immediately when door is opened and turns on again immediately when door is closed. Broil elements will turn off approximately 30 seconds after the door is opened. They will turn on again approximately 30 seconds after the door is closed.

TEMPERATURE PROBE

⚠ WARNING
Burn Hazard
Use an oven mitt to remove temperature probe.
Do not touch broil element.
Failure to follow these instructions can result in burns.

The temperature probe accurately measures the internal temperature of meat, poultry and casseroles with liquid and should be used in determining the doneness of meat and poultry. It should not be used during full and center broiling, convection broiling, dehydrating or proofing bread.

Always unplug and remove the temperature probe from the oven when removing food.

— NOTES —

COMPONENT ACCESS

This section instructs you on how to service each component inside the KitchenAid 27" & 30" Electric Built-In Double Oven. The upper oven components and their locations are shown below. The lower oven component locations are shown on page 4-23.

COMPONENT LOCATIONS *Upper Oven Components*

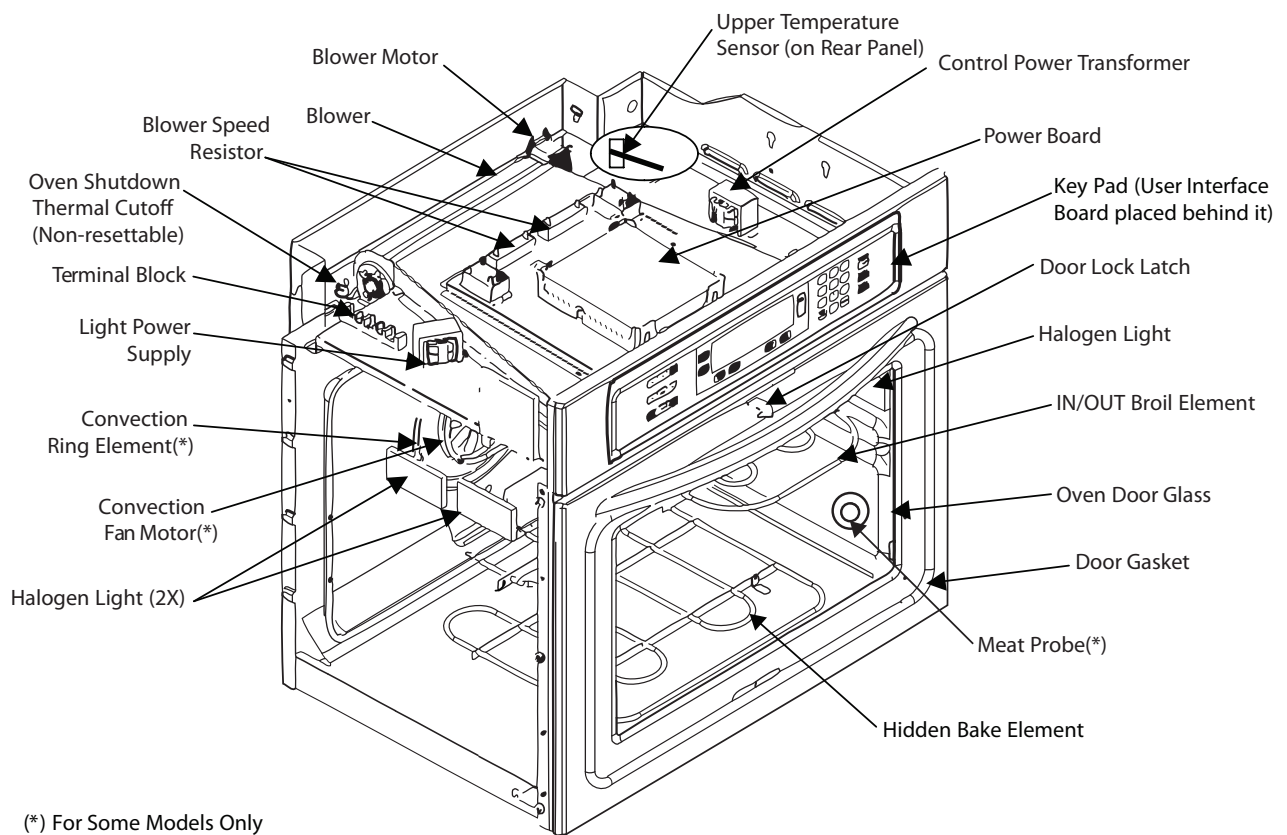

REMOVING THE KEYPAD AND USER INTERFACE BOARD

⚠ WARNING



Electrical Shock Hazard

Disconnect power before servicing.
Replace all parts and panels before operating.

Failure to do so can result in death or electrical shock.

1. Unplug oven or disconnect power.
2. Open the upper oven door, remove the two flat-head screws from the bottom of the control panel frame, and remove the frame.

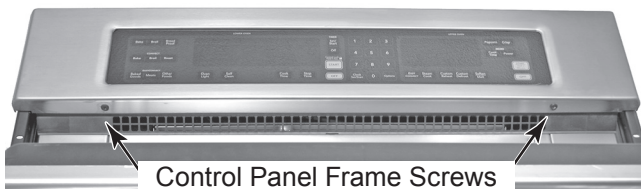

3. Remove two keypad retainer screws on right side of keypad.

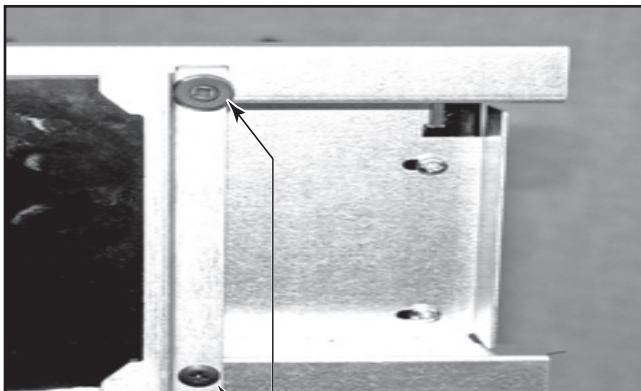

Keypad Retainer Screws

4. Remove the three screws from the front user interface board and remove the user interface board from inner frame.

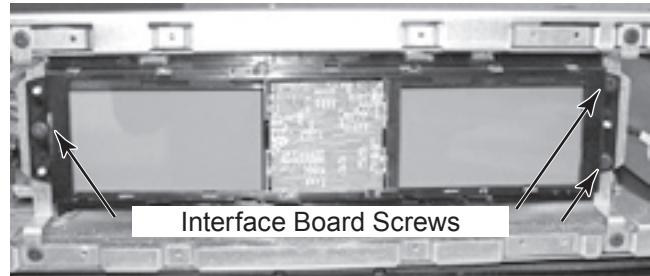

5. Disconnect wire connections from interface board and remove.

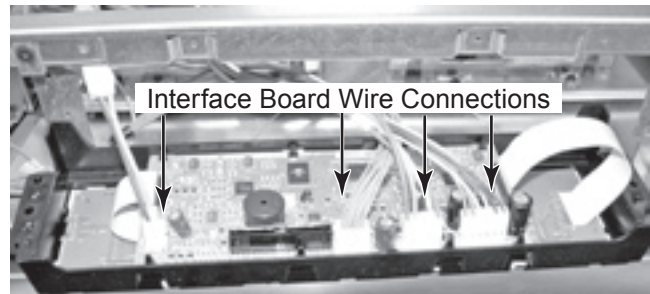

REMOVING THE OVEN APPLIANCE MANAGER

⚠ WARNING



Electrical Shock Hazard
Disconnect power before servicing.
Replace all parts and panels before operating.
Failure to do so can result in death or electrical shock.

1. Unplug oven or disconnect power.

⚠ WARNING

Excessive Weight Hazard
Use two or more people to move and install oven.
Failure to do so can result in back or other injury.

2. Remove the oven from its mounting location (see "Installation Information" in Section 2) and pull it forward so that you can access the top cover.
3. Remove the six screws from the top cover and remove conduit screw and remove the cover.

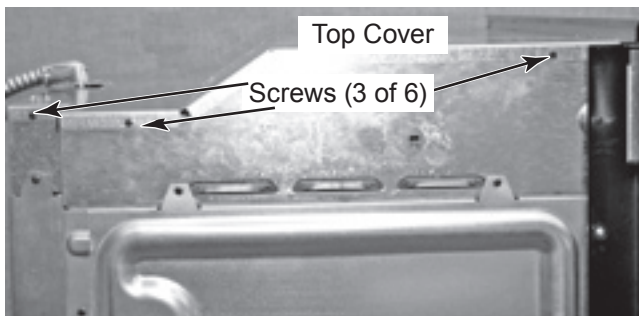

4. Unhook and remove the AC wiring conduit connector from the back of the cover (see the photo below).

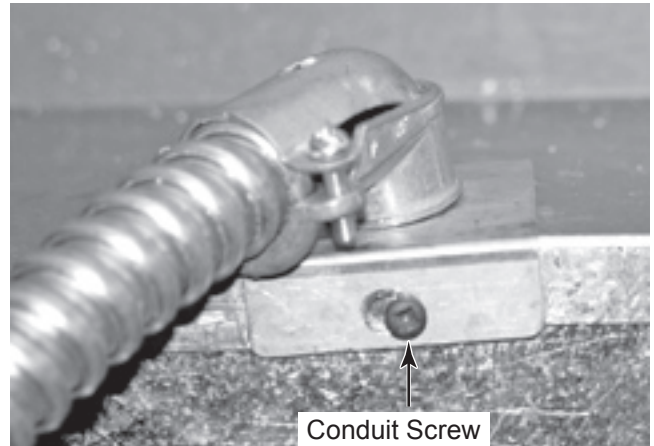

Continued on the next page.

5. Disconnect the wire connectors from the oven appliance manager board pins. The wire connector colors are as follows:
 T3 = OR, RD, YL, BU
 T4 = 4 BK
 T5 = OR, RD, YL, BU
 T10 = BK/WH, BK/WH, BK
 P9 = OR/WH, GK, YL, BK
 P8 = BK, OR, GY, YL, BK/WH
 P7 = RD, WH
 P2 = 2 VI, OR, WH
 P1 = TN, BR, OR, TN, BR, OR
 P5 = GN, R/W
 P6 = BR, OR, YL, BU
6. Remove the four lower oven appliance manager housing screws and remove the housing assembly.

7. Unclip the six tabs from the lower oven appliance manager and remove it from the housing.

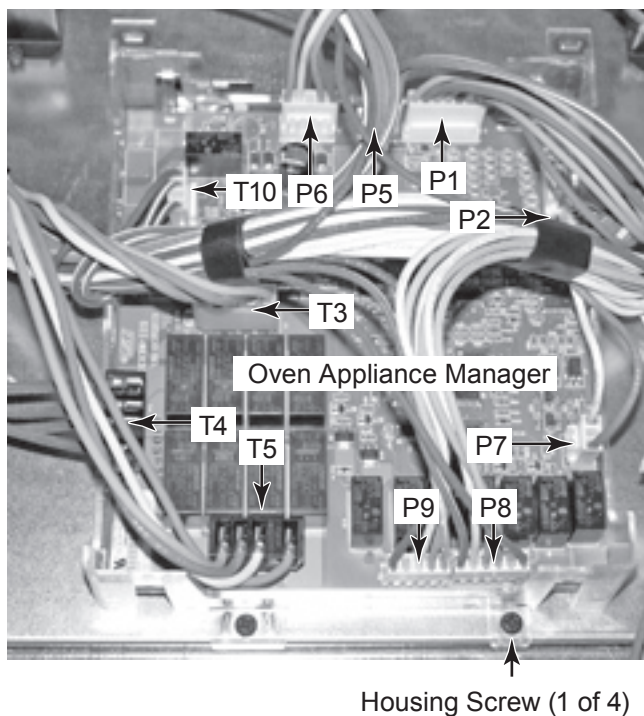
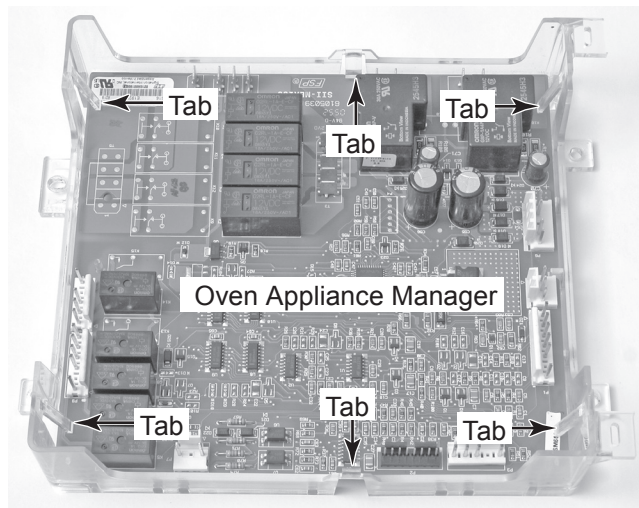

REMOVING THE OVEN LIGHT TRANSFORMER

⚠ WARNING



Electrical Shock Hazard
Disconnect power before servicing.
Replace all parts and panels before operating.
Failure to do so can result in death or electrical shock.

1. Unplug oven or disconnect power.

⚠ WARNING

Excessive Weight Hazard
Use two or more people to move and install oven.
Failure to do so can result in back or other injury.

2. Remove the oven from its mounting location (see “Installation Information” in Section 2) and pull it forward so that you can access the top cover.
3. Remove the top cover from the oven (see page 4-3 for the procedure).

4. To remove the oven light transformer:
 - a) Disconnect the four wire connectors from the transformer terminals.
 - b) Remove the two screws from the transformer and remove it.

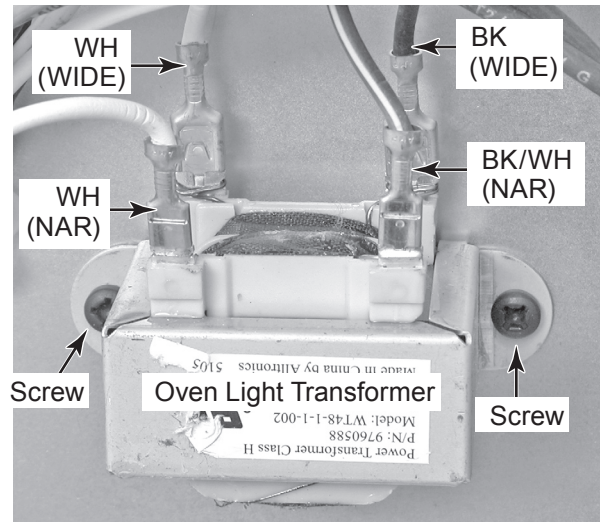

REMOVING THE AC TERMINAL BLOCK

⚠ WARNING



Electrical Shock Hazard

Disconnect power before servicing.

Replace all parts and panels before operating.

Failure to do so can result in death or electrical shock.

1. Unplug oven or disconnect power.

⚠ WARNING

Excessive Weight Hazard

Use two or more people to move and install oven.

Failure to do so can result in back or other injury.

2. Remove the oven from its mounting location (see “Installation Information” in Section 2) and pull it forward so that you can access the top cover.
3. Remove the top cover from the oven (see page 4-3 for the procedure).

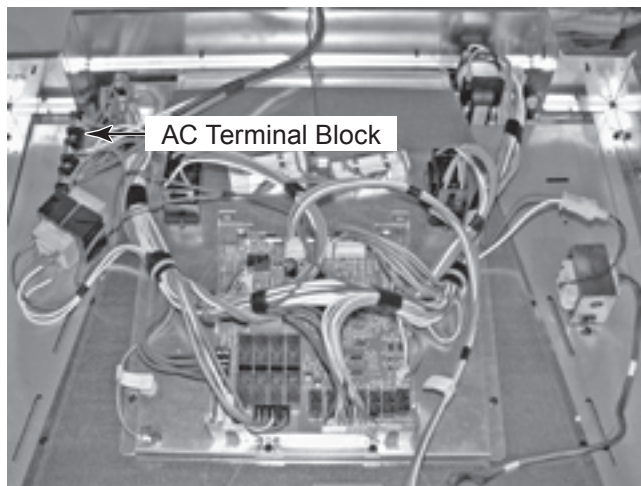

4. Remove the nuts from the black, white, and red wires and remove the wires from the terminal block studs.
5. Remove the two mounting screws from the terminal block and remove it from the side cover.

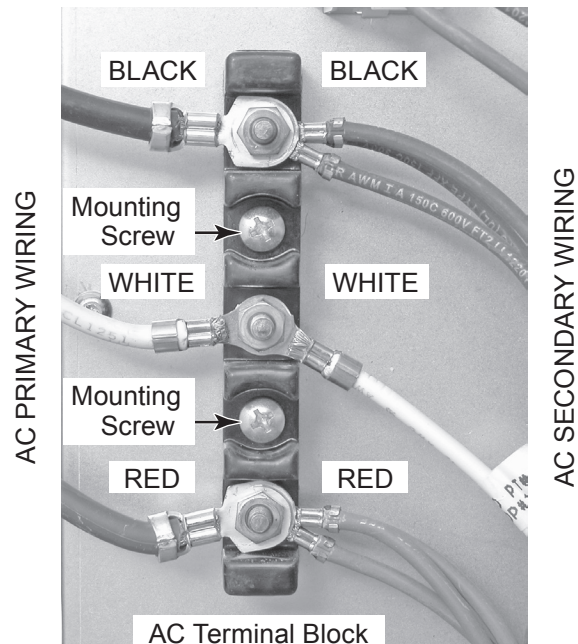

REMOVING THE UPPER DOOR LATCH ASSEMBLY

⚠ WARNING



Electrical Shock Hazard

Disconnect power before servicing.

Replace all parts and panels before operating.

Failure to do so can result in death or electrical shock.

1. Unplug oven or disconnect power.

⚠ WARNING

Excessive Weight Hazard

Use two or more people to move and install oven.

Failure to do so can result in back or other injury.

2. Remove the oven from its mounting location (see “Installation Information” in Section 2) and pull it forward so that you can access the top cover.
3. Remove the six screws from the top cover and remove conduit screw and remove the cover.

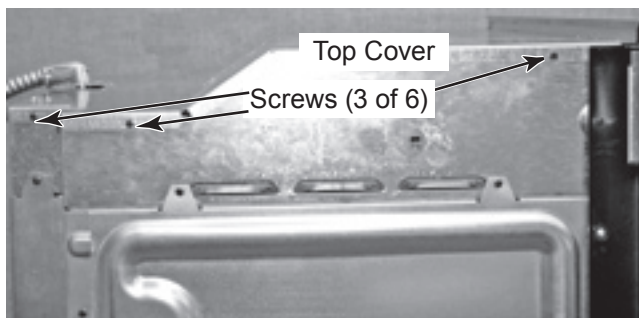

4. Unhook and remove the AC wiring conduit connector from the back of the cover

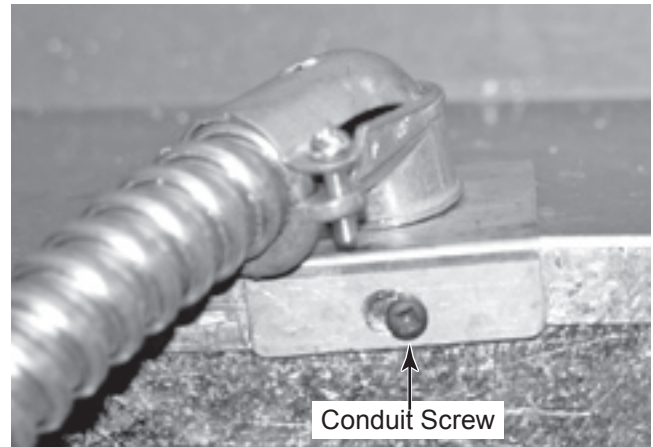

5. Open the upper oven door, remove the two flat-head screws from the bottom of the control panel frame, and remove the frame.

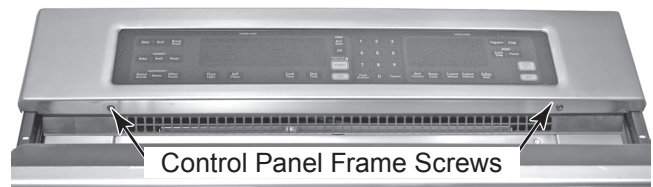

6. Remove the four screws from the front control subpanel, remove the subpanel assembly, and lay it on top of the oven.



7. Remove the four screws from the upper oven air vent and remove the vent.

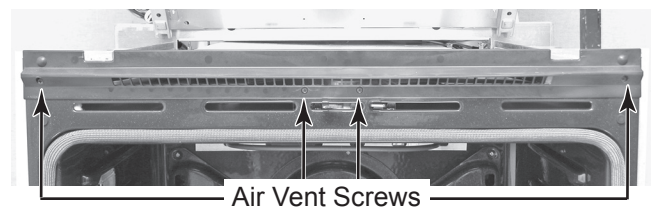

Continued on the next page.

- Remove the three screws from the appliance manager mounting bracket and slide back to expose top air duct latch cover.

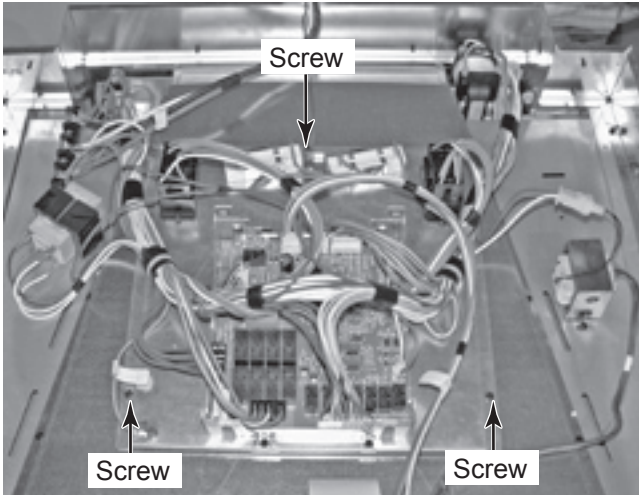

- Bend and break the two front tabs on the top air duct latch assembly cover.
- Using a pair of side-cutters, cut the two front joins on the top air duct latch assembly cover, then bend the top and bottom covers up as far as they will go.

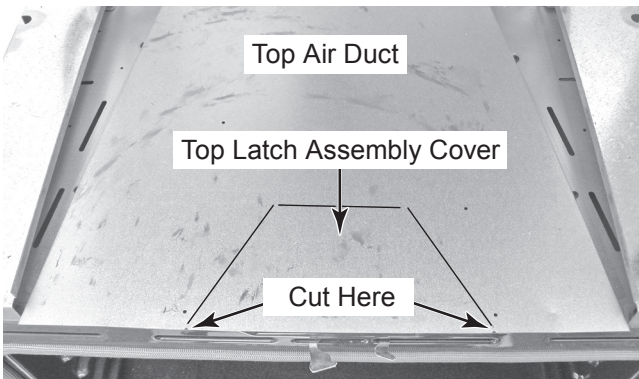

- Remove the two screws from the door latch assembly, pull the latch assembly back to remove the latches from the cutouts, and then lift and pull it forward so that you can access the wiring.

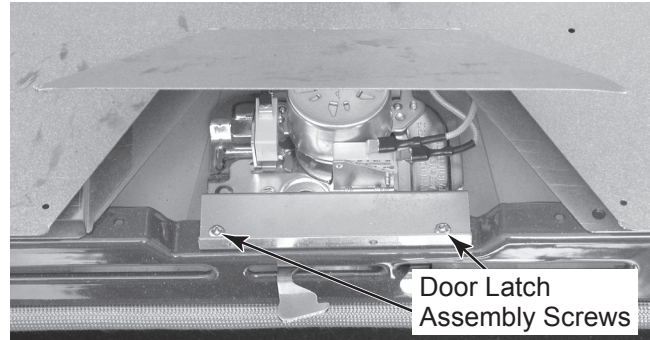

- Disconnect the wires from the assembly as follows:

Latch motor = yellow & white
 Door switch = brown (C) & orange (N.O.)
 Latch switch = tan (C) & blue (N.O.)

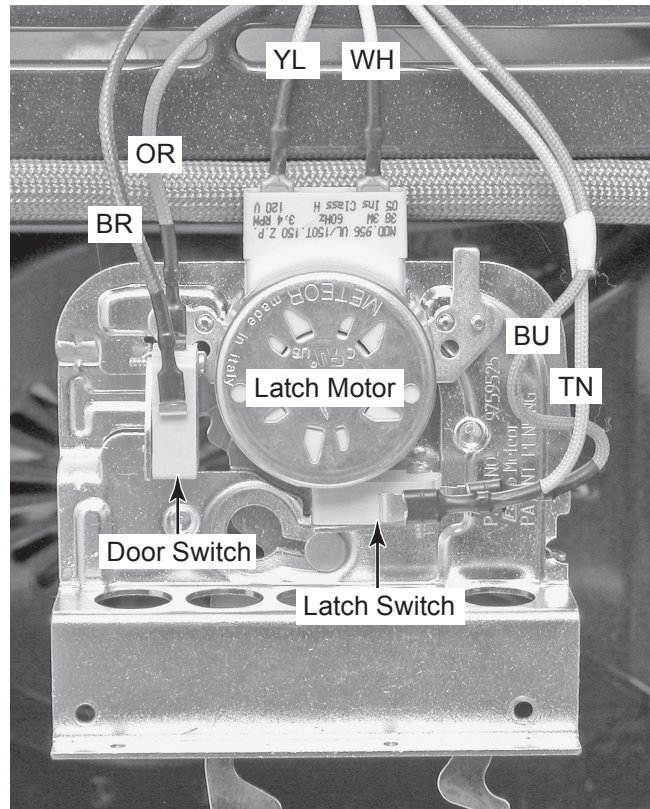

13. **To remove the latch motor**, remove the two motor screws from the bottom of the assembly.

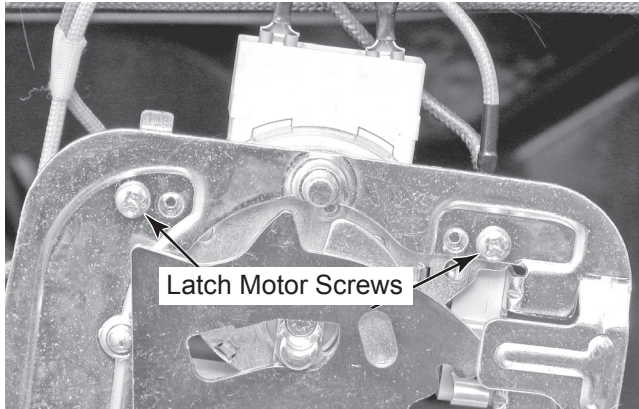

14. **To remove the door or latch switch**, remove the bracket screw. **NOTE:** You will have to remove the latch motor (in step 9) to access the door or latch switch screws.

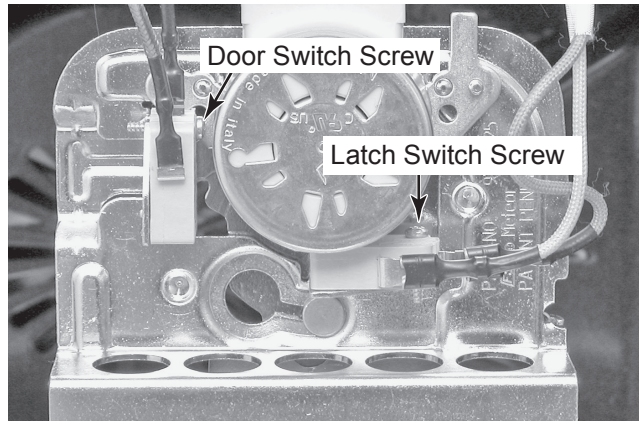

REASSEMBLY NOTE: After you reinstall the door latch assembly in the oven, press the two covers back down into place. Use a piece of shipping tape and tape over the front edge of the top cover to hold it in place and keep it from vibrating during operation.

REMOVING THE UPPER BROIL ELEMENT AND THE UPPER OVEN TEMPERATURE SENSOR

⚠ WARNING



Electrical Shock Hazard

**Disconnect power before servicing.
Replace all parts and panels before
operating.**

**Failure to do so can result in death or
electrical shock.**

1. Unplug oven or disconnect power.
2. Open the upper oven door.

Broil Element Temperature Sensor

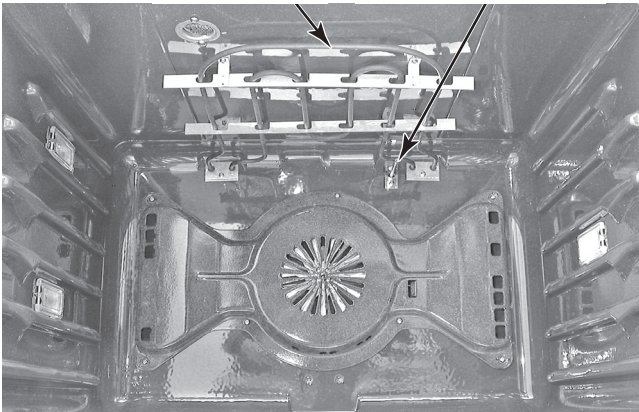

3. To remove the broil element:

- a) Remove the four screws from the front and rear brackets (see the top right photo).

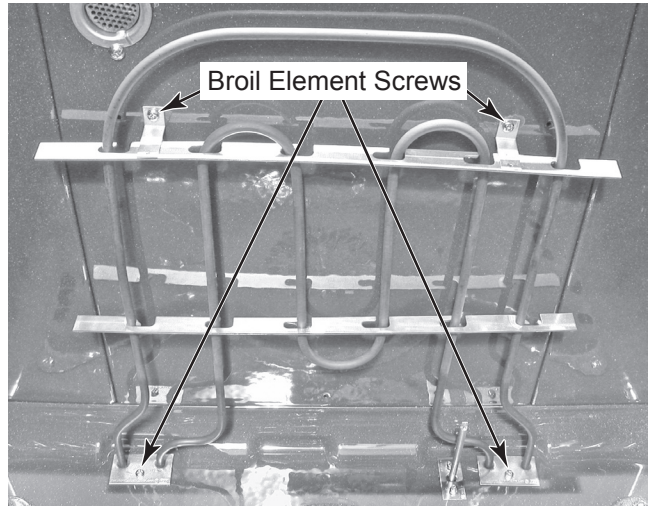

- b) Pull the broil element forward until you can access the wire terminals.
- c) Disconnect the orange and blue wire connectors from the broil element terminals and remove the element.

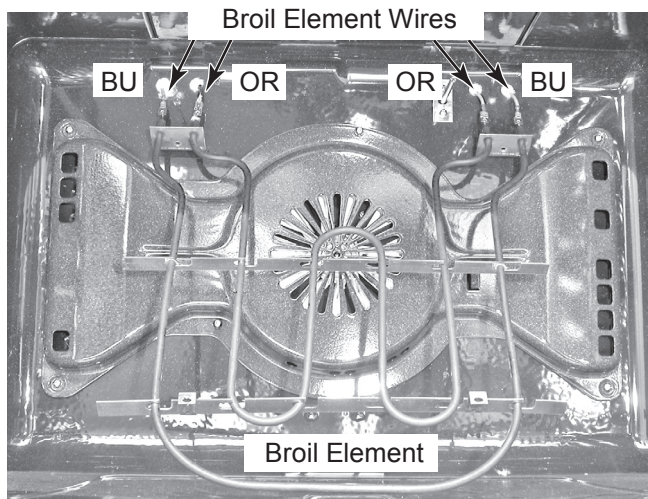

4. To remove the oven temperature sensor:

- a) Remove the screws from the sensor bracket.

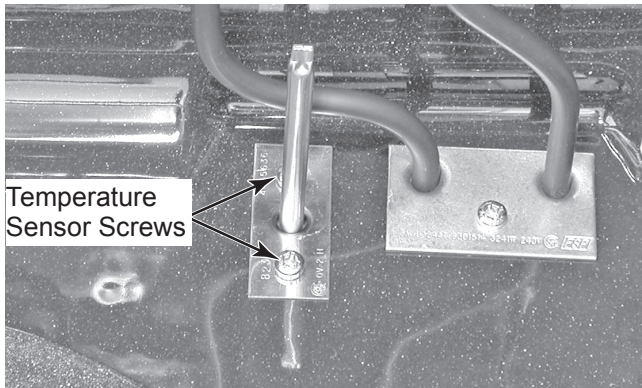

- b) Remove the oven from its mounting location (see "Installation Information" in Section 2) and pull it forward so that you can access the top cover.
- c) Remove the six screws from the top cover and remove the cover.

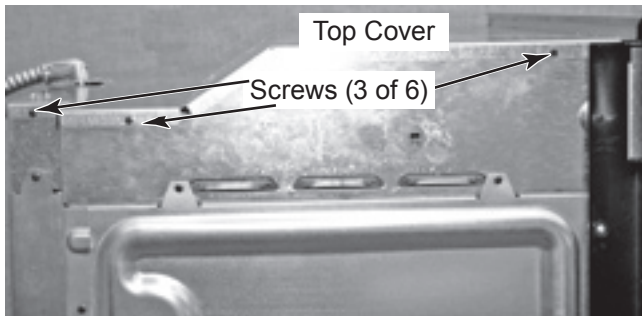

- d) Remove the twelve screws from the rear cover and remove the cover.

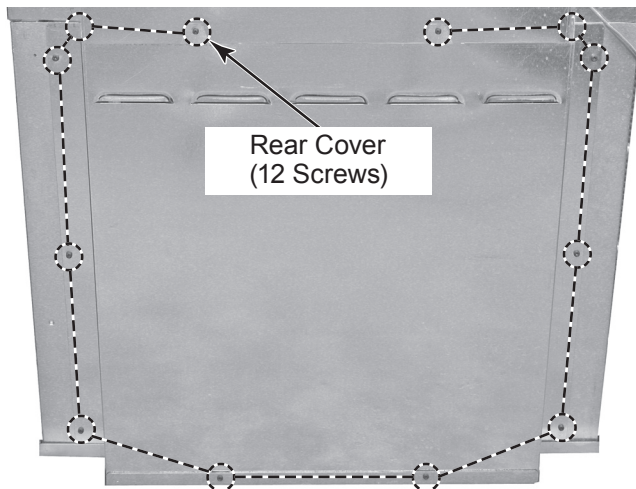

- e) Disconnect the sensor wire connector from the wiring harness.
- f) Push the sensor wire connector through the oven liner hole from the rear of the oven.

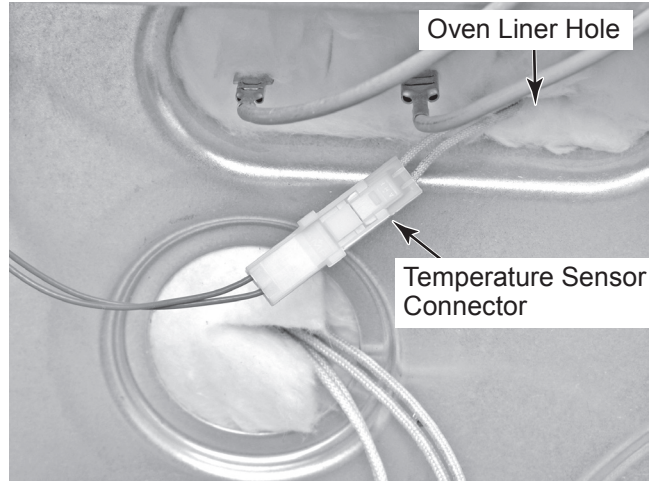

- g) Pull the temperature sensor connector out of the hole and remove the sensor.

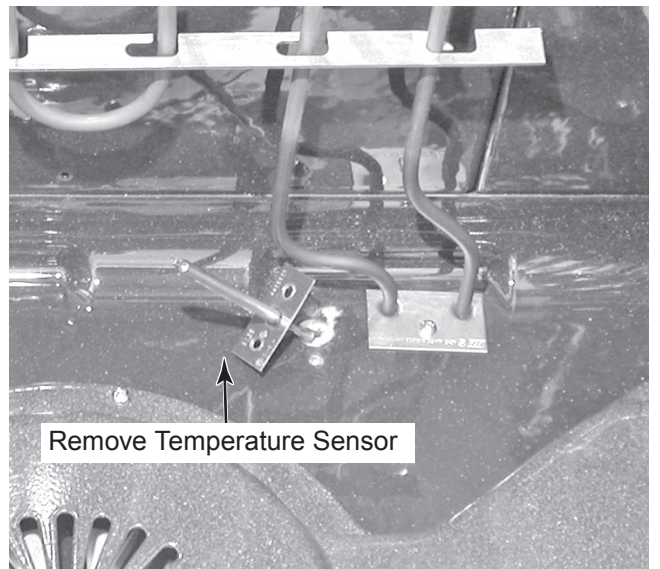

REMOVING THE UPPER CONVECTION RING ELEMENT AND CONVECTION FAN MOTOR

⚠ WARNING



Electrical Shock Hazard

Disconnect power before servicing.

Replace all parts and panels before operating.

Failure to do so can result in death or electrical shock.

1. Unplug oven or disconnect power.
2. Open the upper oven door.
3. Remove the seven screws from the convection cover and remove the cover.

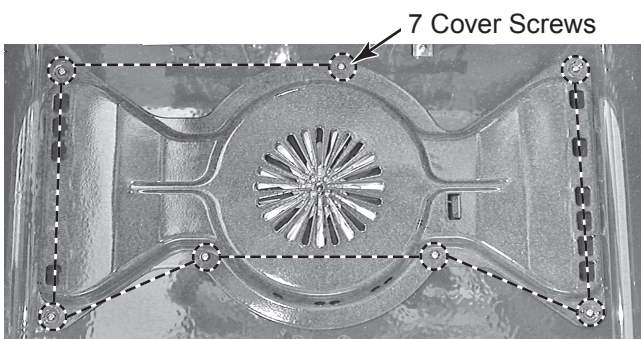
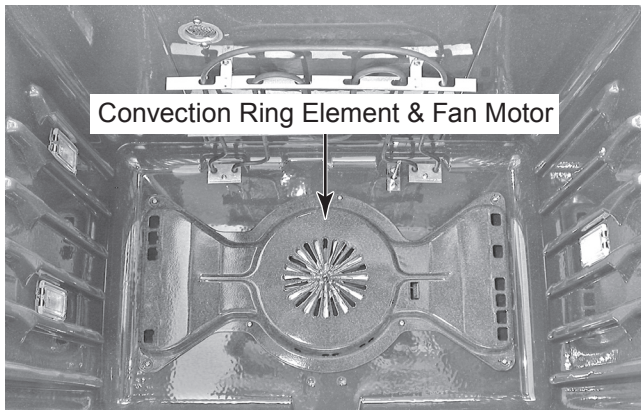

4. To remove the convection ring element:
 - a) Remove the two screws from the element brackets.

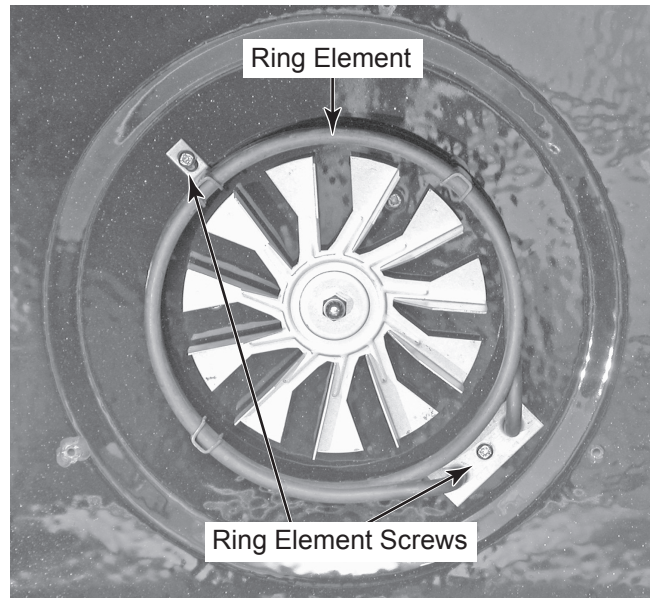

- b) Pull the convection ring element forward far enough to access the two wire connectors.
- c) Disconnect the wire connectors from the convection ring element terminals and remove the element.

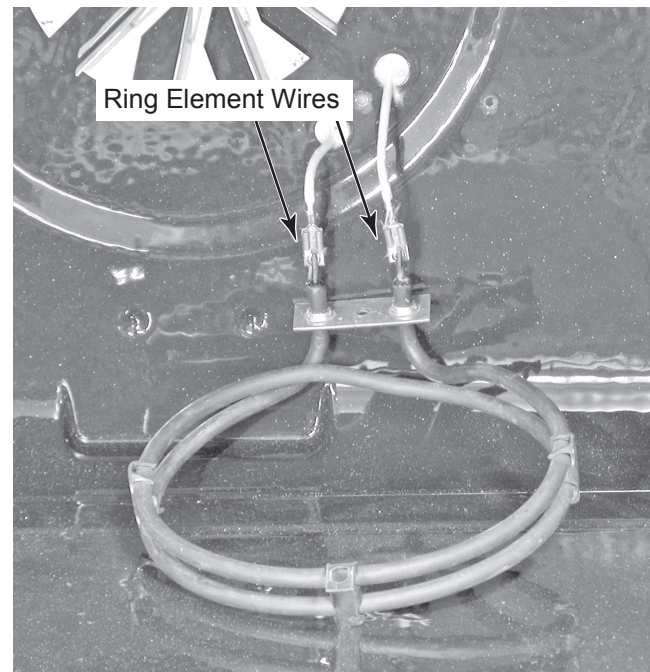

5. **To remove the convection fan motor:**

- a) Remove the 10mm hex nut from the convection fan blade (left-hand rotation) and remove the blade from the motor shaft.

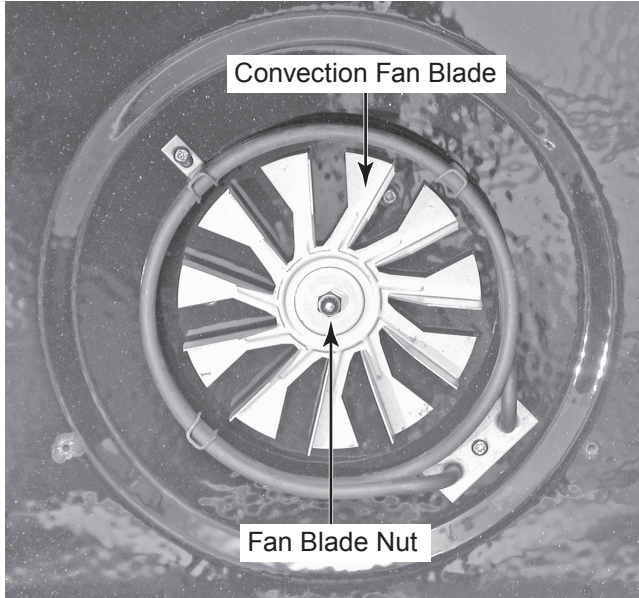

- b) Remove the three front screws from the convection fan motor.

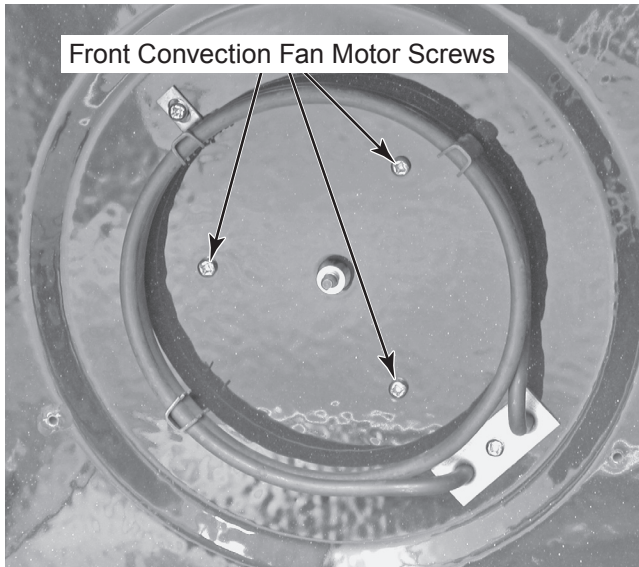

- c) Remove the oven from its mounting location (see "Installation Information" in Section 2) and pull it forward so that you can access the rear covers.

- d) Remove the twelve screws from the upper rear cover and remove the cover.

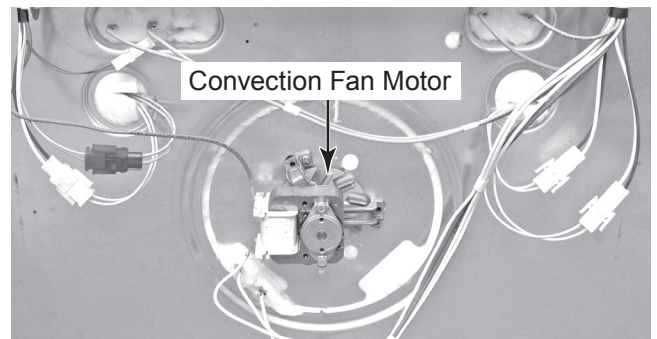
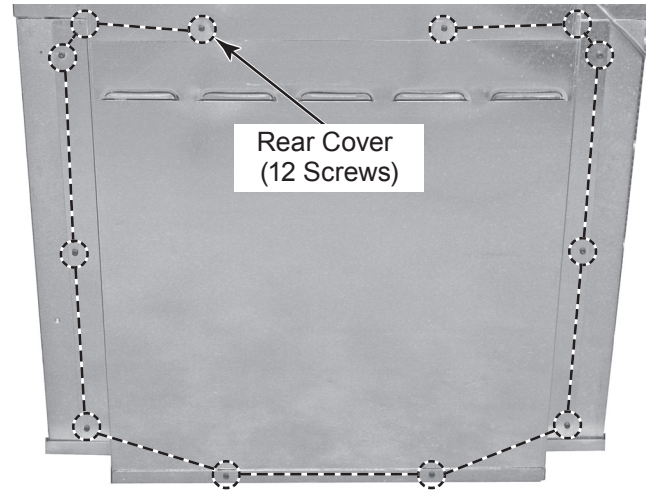

- e) Disconnect the red and yellow wires from the convection fan motor terminals.
- f) Remove the two screws from the fan motor and remove the motor.

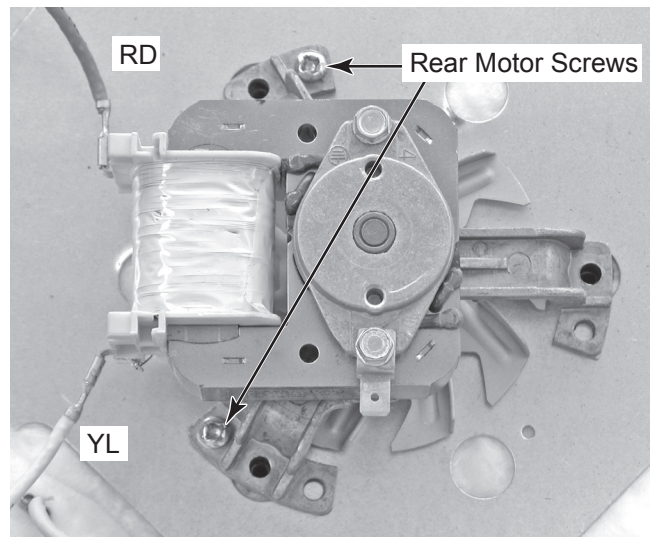

REMOVING UPPER HALOGEN LIGHT ASSEMBLY AND MEAT PROBE JACK

⚠ WARNING



Electrical Shock Hazard

Disconnect power before servicing.

Replace all parts and panels before operating.

Failure to do so can result in death or electrical shock.

1. Unplug oven or disconnect power.
2. Open the upper oven door.

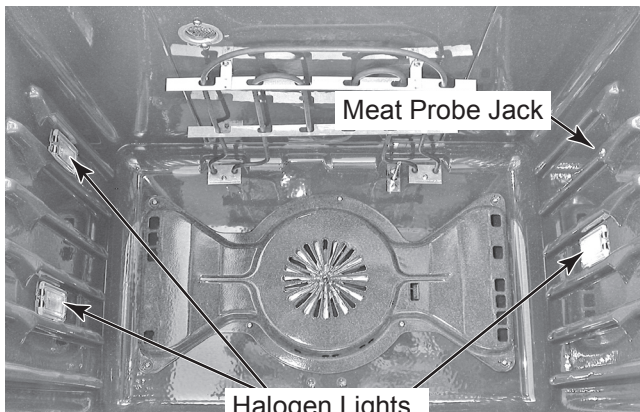

3. To remove a halogen light assembly:

- a) Remove the screw from the lens.

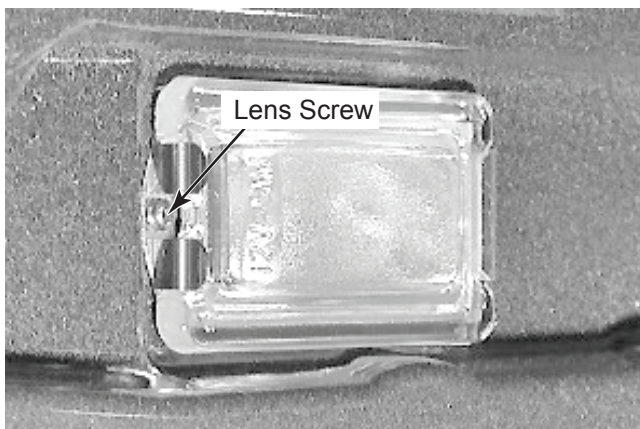

- b) Unclip the lens from the socket and remove the lens.

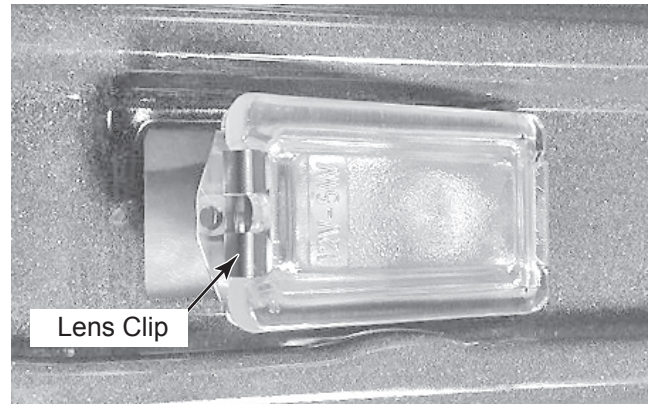

- c) Remove the halogen bulb from the socket connector.

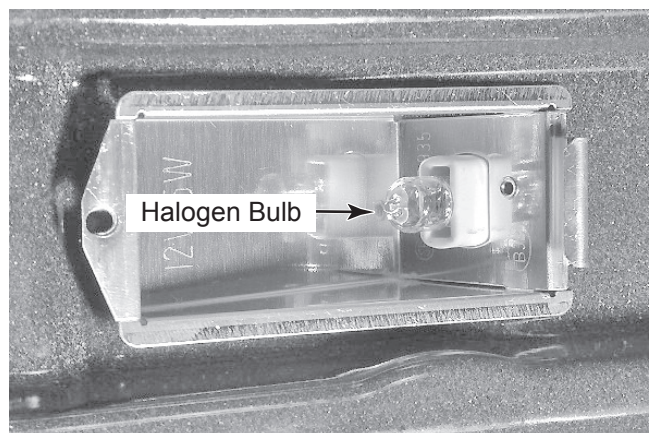

- d) Cut the wires near the socket body and splice the new socket in its place.

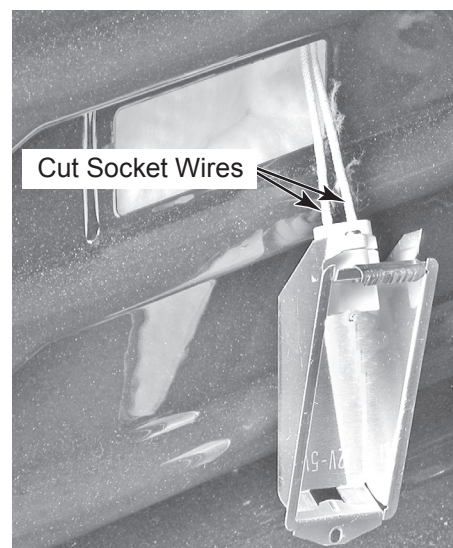

4. **To remove the meat probe jack:**

- a) Remove the nut from the meat probe jack.

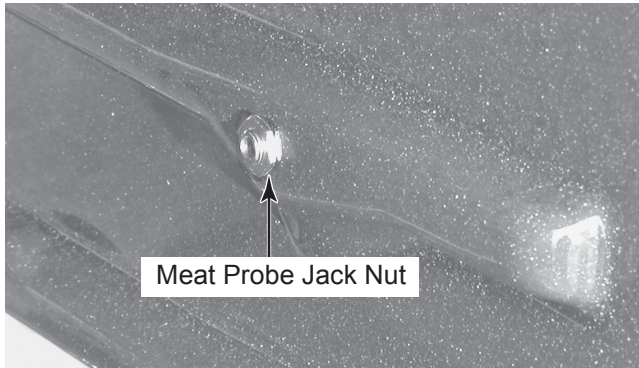

- b) Remove the oven from its mounting location (see "Installation Information" in Section 2) and pull it forward so that you can access the meat probe jack access cover on the right side of the oven.

⚠ WARNING

Excessive Weight Hazard
Use two or more people to move and install oven.
Failure to do so can result in back or other injury.

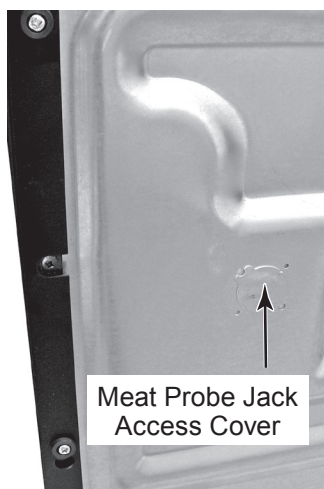

- c) Use a pair of side-cutters and cut the meat probe jack access cover from the right side cover (see the top right photo).



- d) Remove the meat probe jack from the right side cover.
- e) Disconnect the wires from the meat probe jack terminals. **NOTE:** Make sure that you reinstall the star washer on the new jack when you install it.

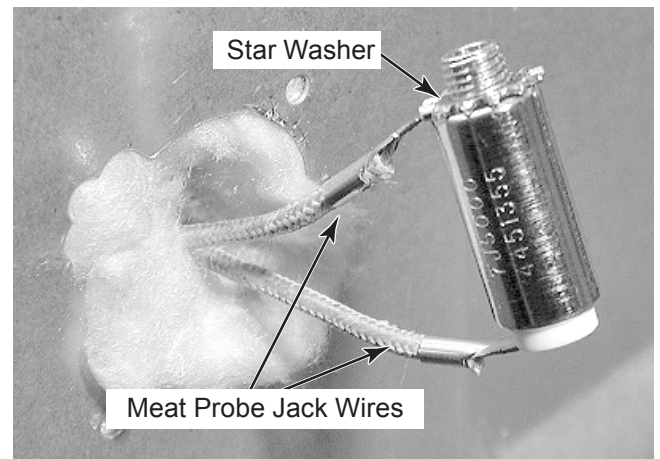

- f) Mount the meat probe jack access cover to the side cover with two screws.

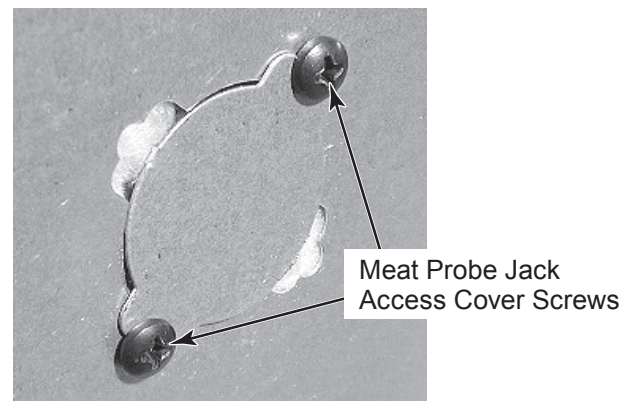

REMOVING UPPER BLOWER ASSEMBLY, BLOWER SPEED RESISTOR, AND OVEN THERMAL CUTOFF

⚠ WARNING



Electrical Shock Hazard

Disconnect power before servicing.

Replace all parts and panels before operating.

Failure to do so can result in death or electrical shock.

1. Unplug oven or disconnect power.

⚠ WARNING

Excessive Weight Hazard

Use two or more people to move and install oven.

Failure to do so can result in back or other injury.

2. Remove the oven from its mounting location (see "Installation Information" in Section 2) and pull it forward so that you can access the top cover.
3. Remove the six screws from the top cover and remove the cover.

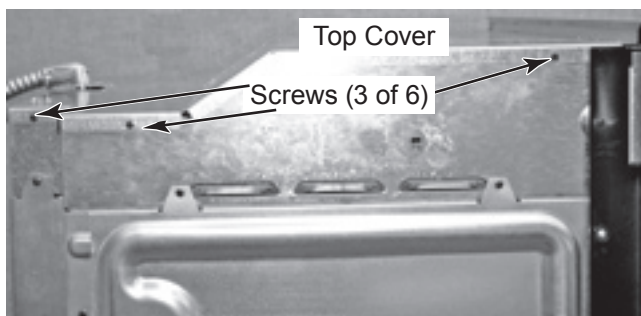

4. Remove the twelve screws from the upper rear cover of the oven and remove the cover.

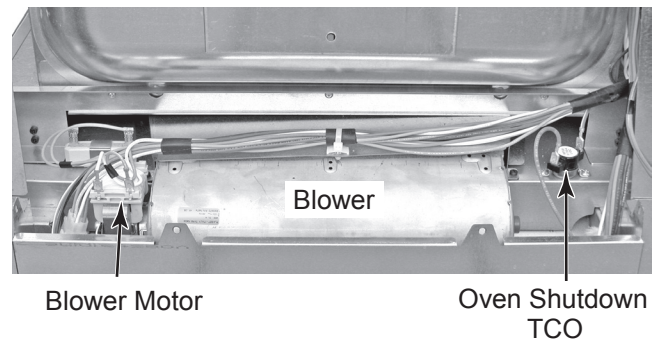
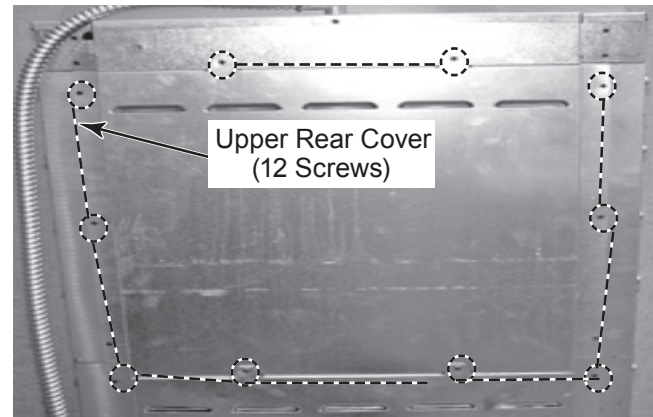

5. **To remove the blower assembly:**
 - a) Disconnect the white and gray wires from the blower motor terminals.
 - b) Remove the two screws from the blower brackets.
 - c) Pull back on the blower assembly while rotating it upwards and remove the assembly.

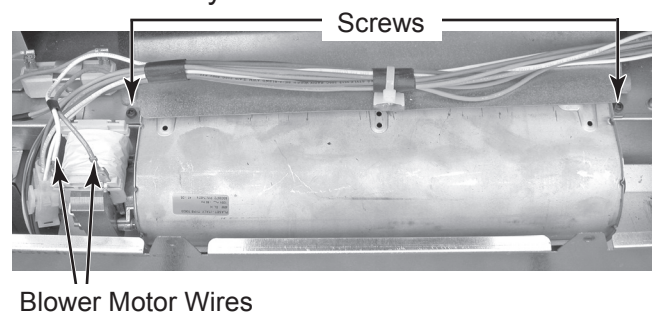

6. To remove the blower speed resistor:

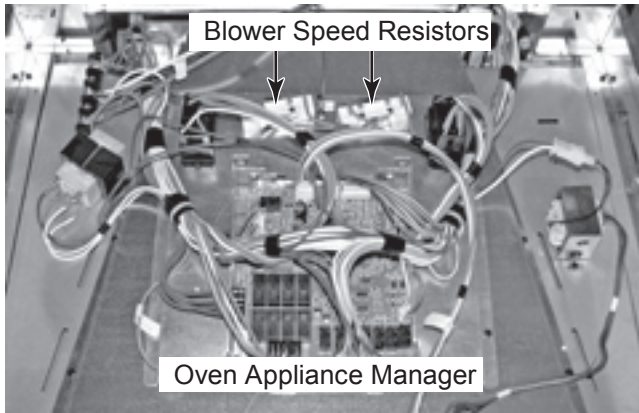

- a) Disconnect the two gray wires from the resistor terminals.
- b) Remove the screw from the resistor bracket and remove the resistor.

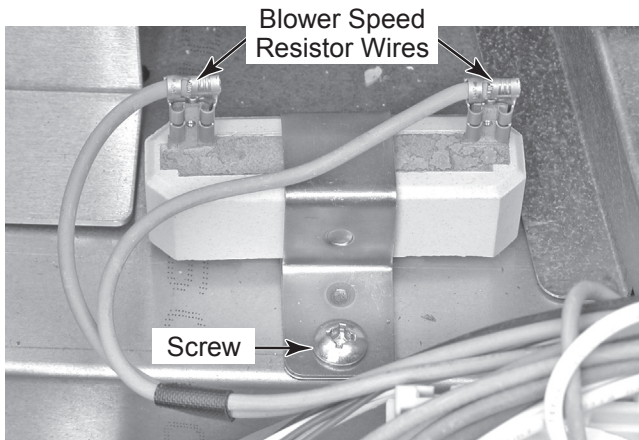

7. To remove the oven thermal cutoff (TCO):

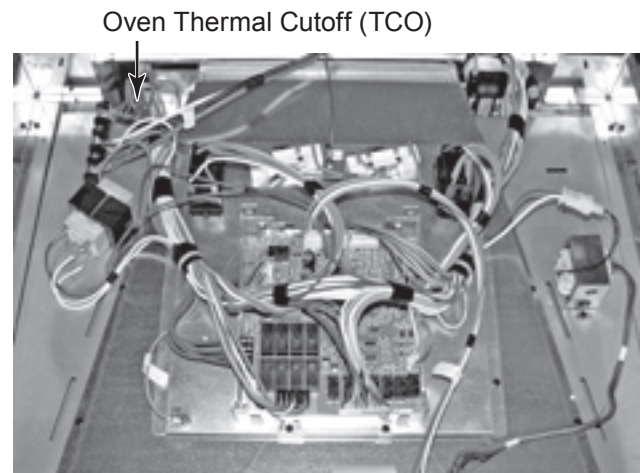

- a) Disconnect the two red wires from the TCO terminals.
- b) Remove the two mounting screws and remove the TCO.

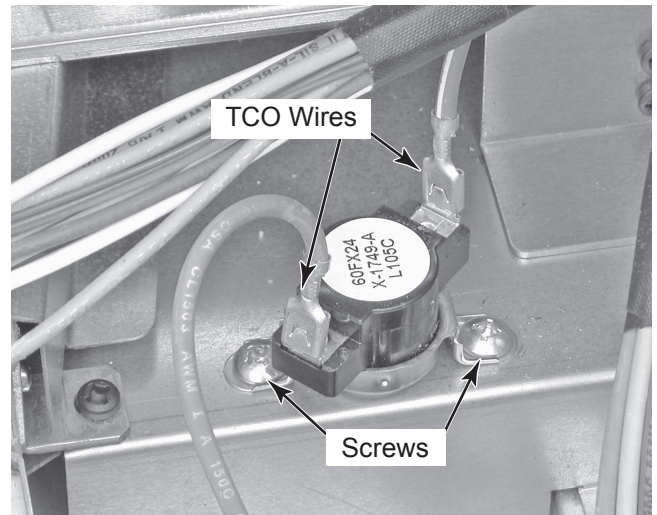

REMOVING UPPER HIDDEN BAKE ELEMENT

⚠ WARNING



Electrical Shock Hazard

Disconnect power before servicing.

Replace all parts and panels before operating.

Failure to do so can result in death or electrical shock.

1. Unplug oven or disconnect power.

⚠ WARNING

Excessive Weight Hazard

Use two or more people to move and install oven.

Failure to do so can result in back or other injury.

2. Remove the oven from its mounting location (see "Installation Information" in Section 2) and pull it forward so that you can access the top cover.
3. Remove the six screws from the top cover and remove the cover.

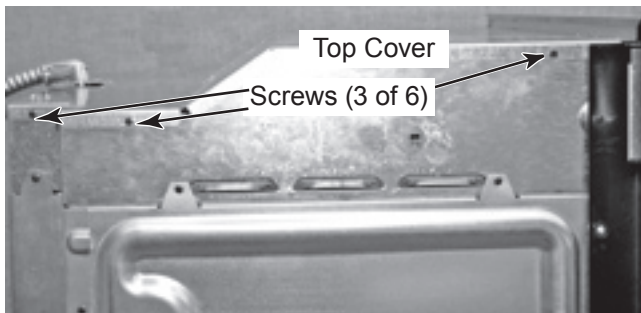

4. Remove the twelve screws from the upper rear cover and remove the cover.

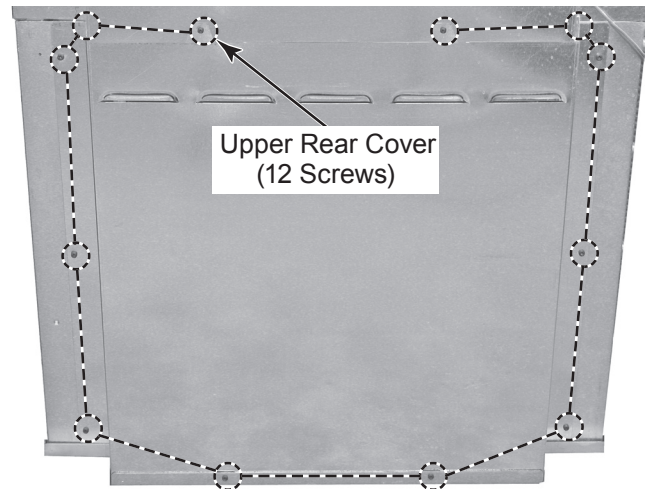

5. Disconnect the two red wires from the hidden bake element terminals.
6. Remove the four screws from the hidden bake element cover.

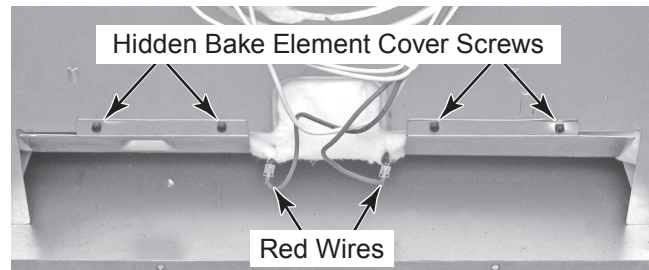

7. Bend the hidden bake element cover flaps down as far as possible.
8. Using a single-edge razor blade, cut the insulation blanket along the bracket edge of the hidden bake element. Spread the blanket apart so you can access the bracket screws.

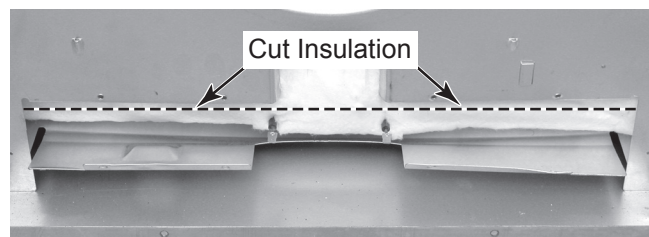

9. Remove the four screws from the hidden bake element bracket.

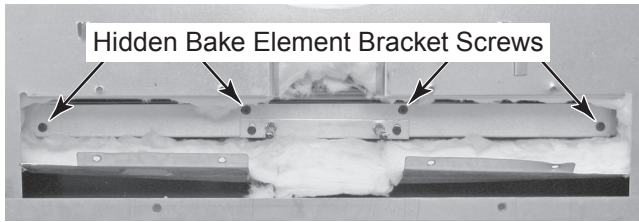

NOTE: When you remove the hidden bake element, press down on the front edge of the panel that is below the element so that it does not interfere with the removal.

10. Pull the hidden bake element out and remove it from the bottom of the oven.
11. Remove the two bracket screws from the hidden bake element and remove the bracket from the element.

REASSEMBLY NOTE: When you install the replacement hidden bake element, press down on the front edge of the panel that is below the element so that it does not interfere with the installation. When installed, the edge of the panel should be below the element bracket so that the bracket fits flush against the chassis.

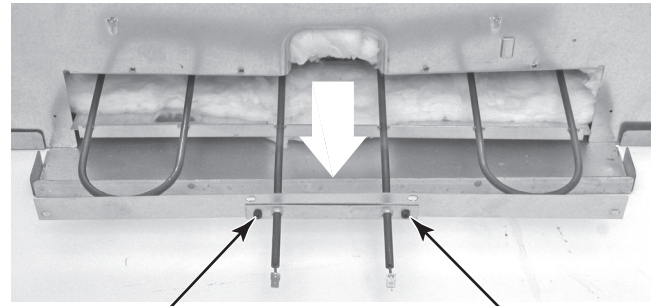

Hidden Bake Element Bracket Screws

REMOVING UPPER OVEN DOOR GLASS AND HANDLE

1. Open the upper oven door.
2. Raise the two door hinge tabs to the “unlocked” position.

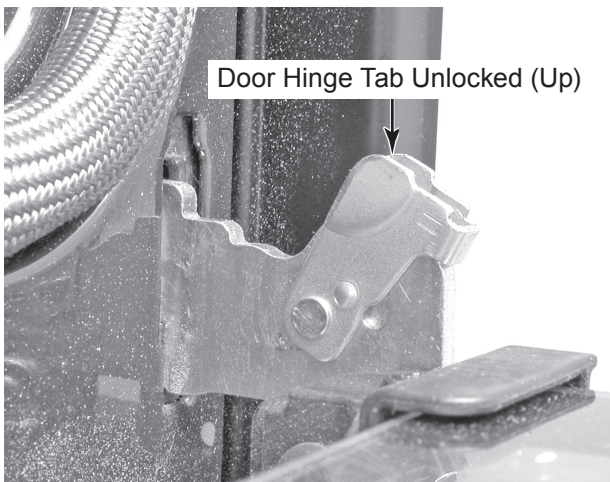

3. Close the oven door to within several inches, lift and pull out on the hinges, and remove them from the oven slots.
4. Place the oven door front side down on a padded surface to protect the finish.
5. Remove the two screws from each of the bottom corner glass holders and remove the holders.
6. **To remove the inner oven door glass panels**, lift each of the three glass panels, and remove them from the door.

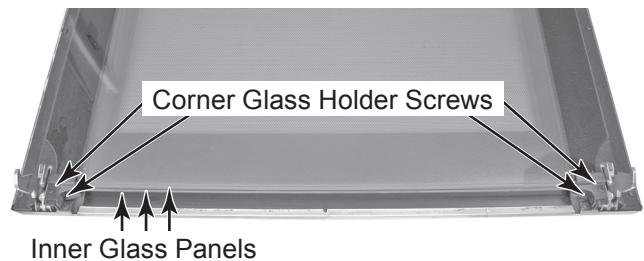

7. **To remove the door handle and outer oven door glass:**
 - a) Remove the three inner glass panels (see step 6).
 - b) Remove the three screws from the air vent and remove the vent.

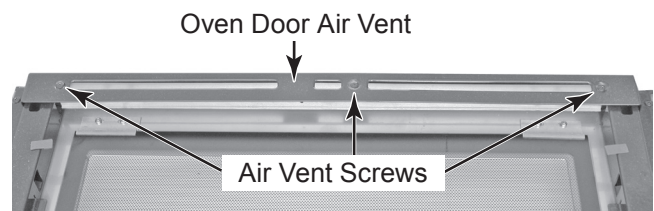

- c) Remove the four door handle bracket screws and remove the brackets and handle from the door.
- d) Slide the bottom edge of the outer oven door glass out of the door frame and remove the glass.

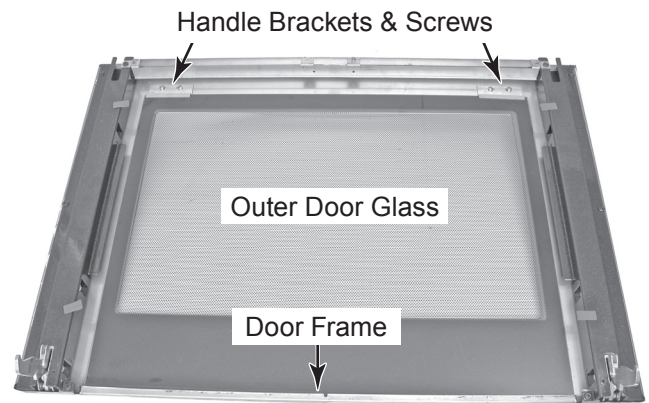

REMOVING UPPER OVEN DOOR GASKET

1. Remove the upper oven door (see the procedure on page 4-19).
2. Remove the screw from the door gasket retainer and remove the retainer.
3. Pull the door gasket clips out of the oven liner holes and remove the gasket.

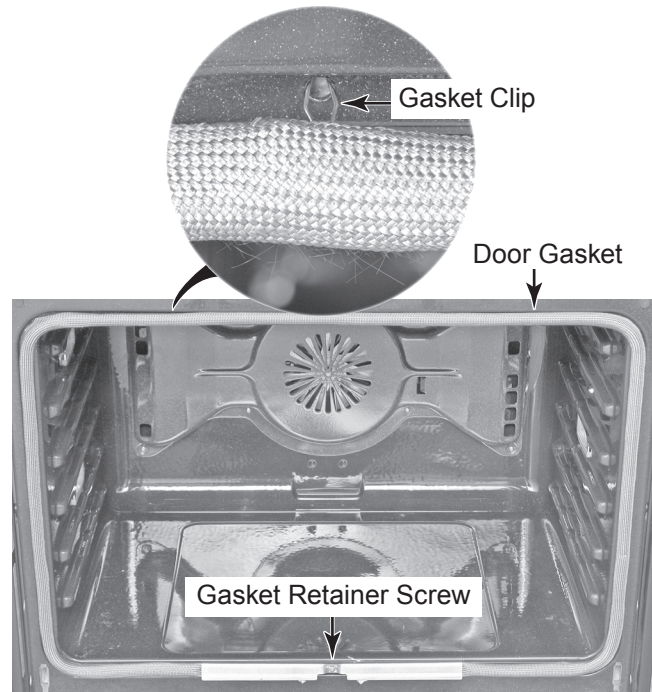

Lower Oven Components

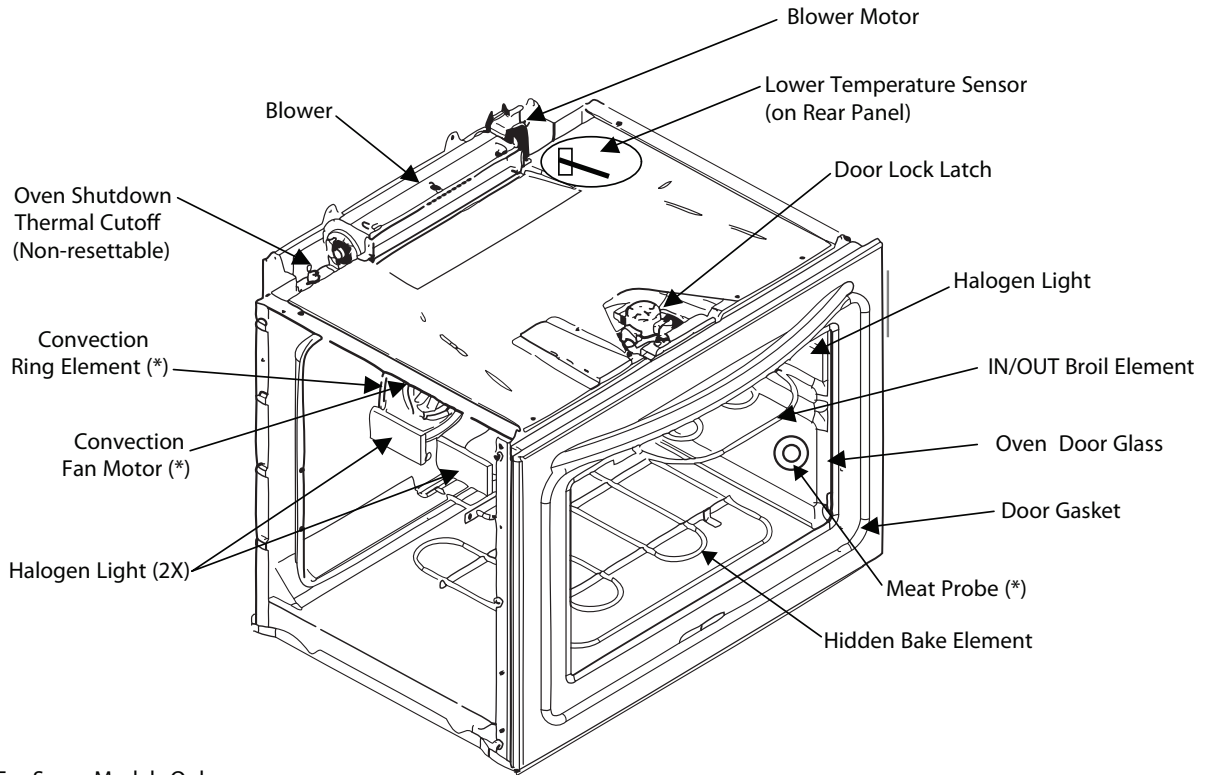

(*) For Some Models Only

REMOVING THE LOWER DOOR LATCH ASSEMBLY

⚠ WARNING



Electrical Shock Hazard

Disconnect power before servicing.

Replace all parts and panels before operating.

Failure to do so can result in death or electrical shock.

1. Unplug oven or disconnect power.

⚠ WARNING

Excessive Weight Hazard

Use two or more people to move and install oven.

Failure to do so can result in back or other injury.

2. Remove the oven from its mounting location (see "Installation Information" in Section 2) and pull it forward so that you can access the top cover.
3. Remove the six screws from the top cover and remove conduit screw and remove the cover.

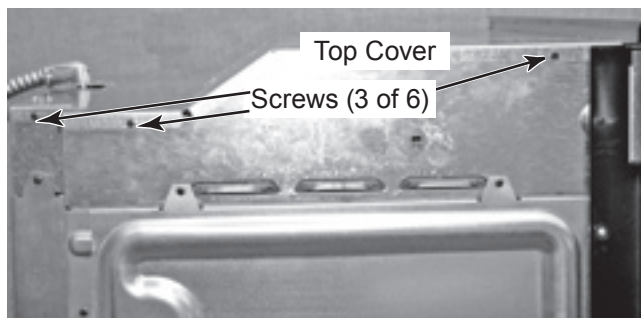

4. Unhook and remove the AC wiring conduit connector from the back of the cover

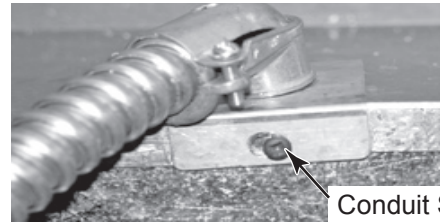

5. Open the upper oven door, remove the two flat-head screws from the bottom of the control panel frame, and remove the frame.

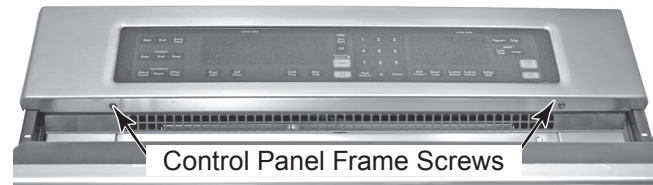

6. Remove the four screws from the front control subpanel, remove the subpanel assembly, and lay it on top of the oven.



7. Remove the seven screws from the left and right rails and remove the rails from the oven.

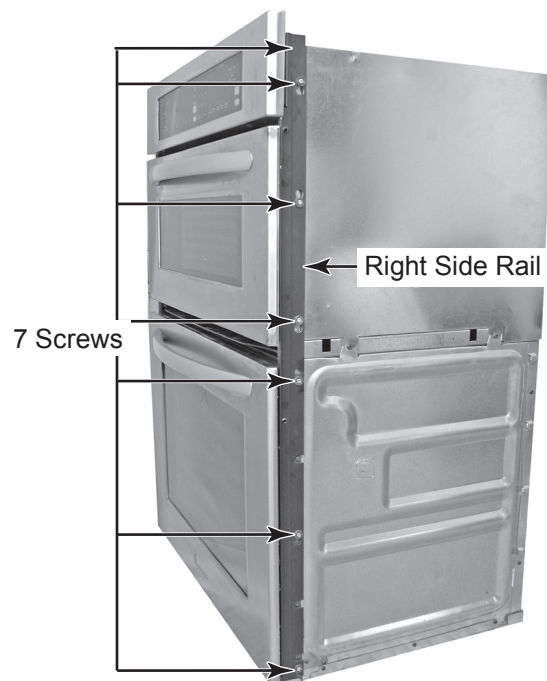

- Remove the twelve screws from the upper rear cover of the oven and remove the cover.

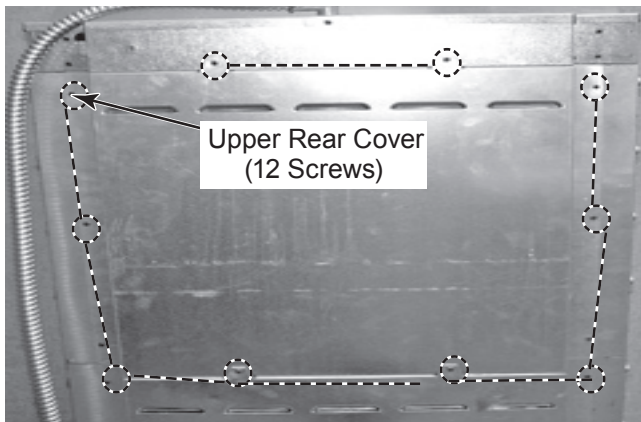

- Remove the four screws from both sides of the oven.

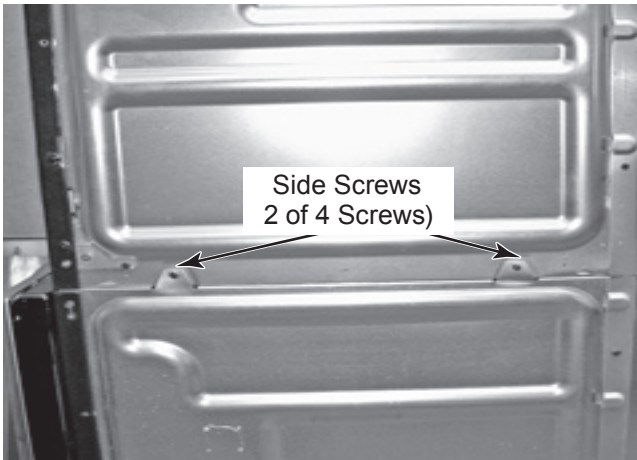

- Remove the four screws from the lower oven air vent and remove the vent.

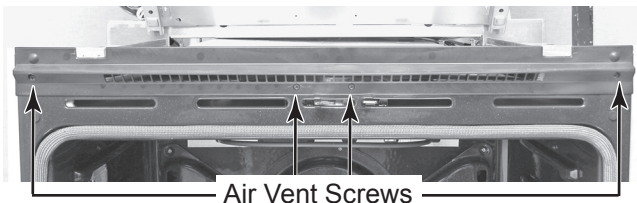

- Set the control subpanel assembly in its place on the front of the oven and hold it in place so it does not fall.

NOTE: You will need something approximately 6-8" long to prop up the front of the upper oven in step 12.

NOTE: You may want to remove upper oven door to lighten the upper oven when lifting in step 12.

- Lift the front of the upper oven and securely prop it up so that you can access the lower door latch assembly.



- Bend and break the two front tabs on the top air duct latch assembly cover.

- Using a pair of side-cutters, cut the two front joints on the top air duct latch assembly cover, then bend the top and bottom covers up as far as they will go.

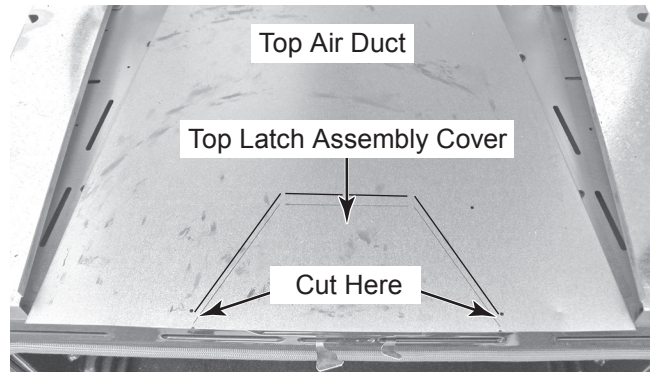

Continued on the next page.

- Remove the two screws from the door latch assembly, pull the latch assembly back to remove the latches from the cutouts, and then lift and pull it forward so that you can access the wiring.

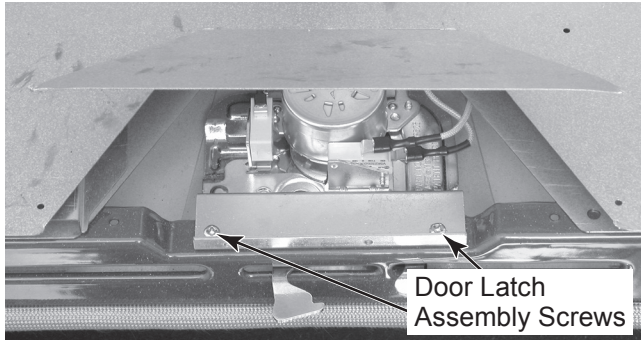

- Disconnect the wires from the assembly as follows:
 Latch motor = yellow & white
 Door switch = brown (C) & orange (N.O.)
 Latch switch = tan (C) & blue (N.O.)

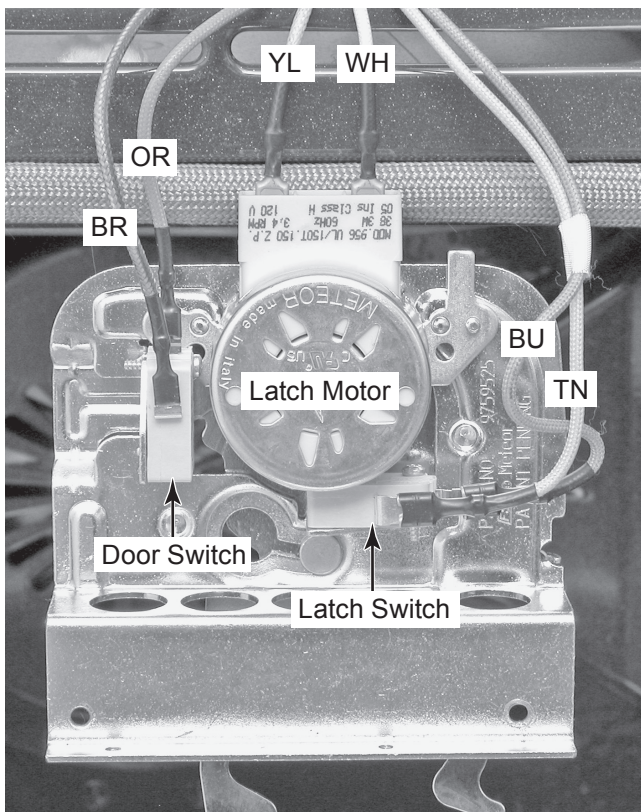

- To remove the latch motor, remove the two motor screws from the bottom of the assembly.

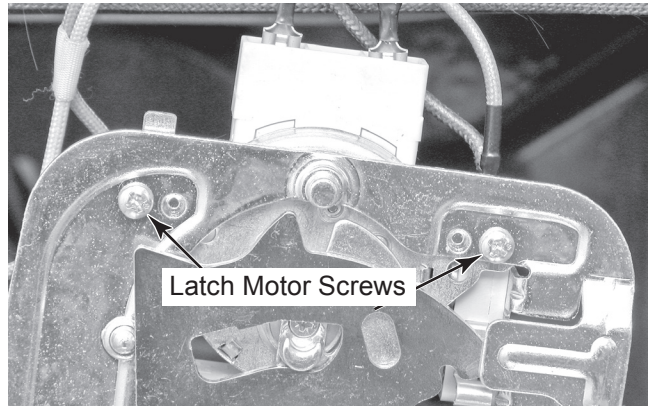

- To remove the door or latch switch, remove the bracket screw. **NOTE:** You will have to remove the latch motor (in step 15) to access the door or latch switch

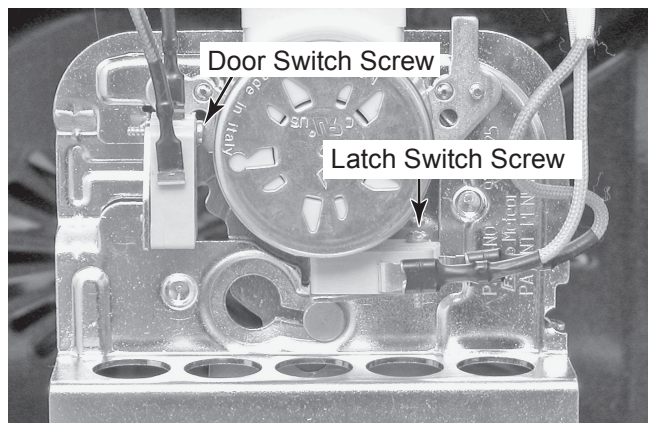

REASSEMBLY NOTE: After you reinstall the door latch assembly in the oven, press the two covers back down into place. Use a piece of shipping tape and tape over the front edge of the top cover to hold it in place and keep it from vibrating during operation.

REMOVING THE LOWER BROIL ELEMENT AND THE LOWER OVEN TEMPERATURE SENSOR

! WARNING



Electrical Shock Hazard
Disconnect power before servicing.
Replace all parts and panels before operating.
Failure to do so can result in death or electrical shock.

1. Unplug oven or disconnect power.
2. Open the lower oven door.

Broil Element Temperature Sensor

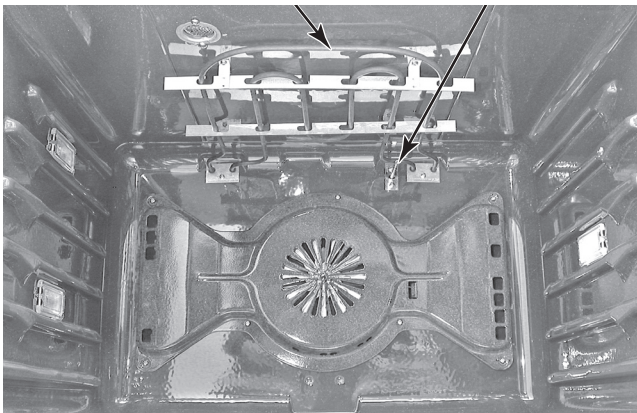

3. To remove the broil element:

- a) Remove the four screws from the front and rear brackets (see the top right photo).

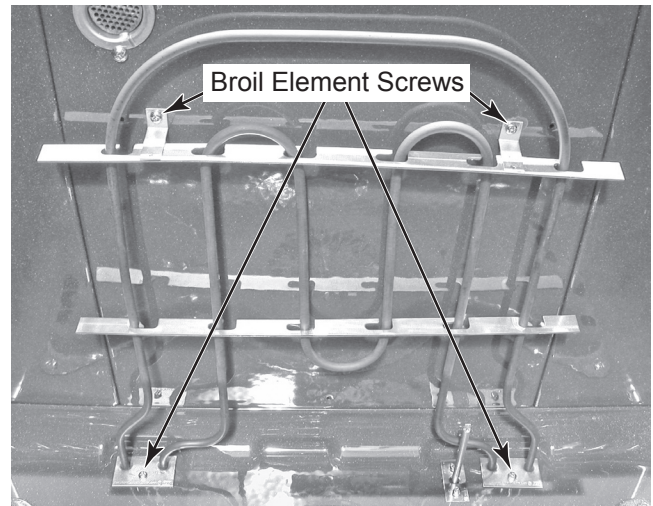

- b) Pull the broil element forward until you can access the wire terminals.
- c) Disconnect the orange and blue wire connectors from the broil element terminals and remove the element.

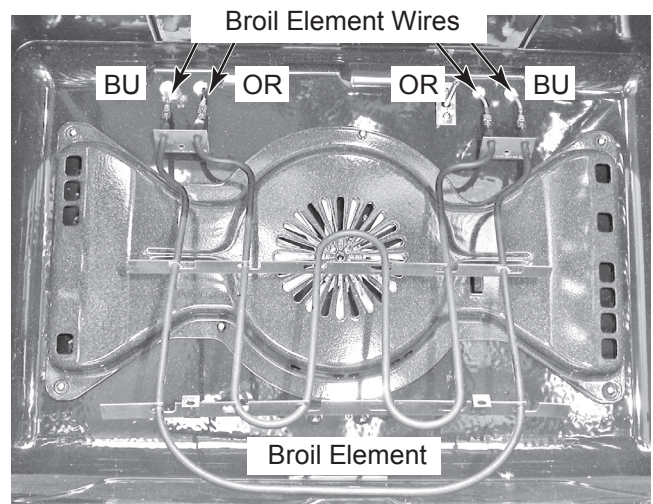

Continued on the next page.

4. To remove the oven temperature sensor:

- a) Remove the screws from the sensor bracket.

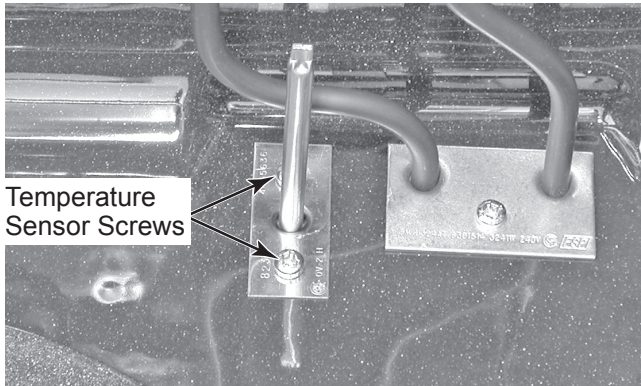

⚠ WARNING



Electrical Shock Hazard
Disconnect power before servicing.
Replace all parts and panels before operating.
Failure to do so can result in death or electrical shock.

A warning box with a black background and white text. It features a warning symbol (a triangle with an exclamation mark) and an icon of a hand being struck by a lightning bolt. The text reads: "Electrical Shock Hazard. Disconnect power before servicing. Replace all parts and panels before operating. Failure to do so can result in death or electrical shock."

- b) Remove the oven from its mounting location (see "Installation Information" in Section 2) and pull it forward so that you can access the top cover.
- c) Remove the six screws from the top cover and remove the cover.

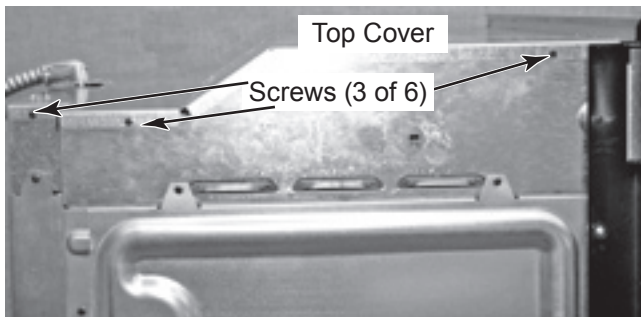

- d) Remove the twelve screws from the lower rear cover and remove the cover.

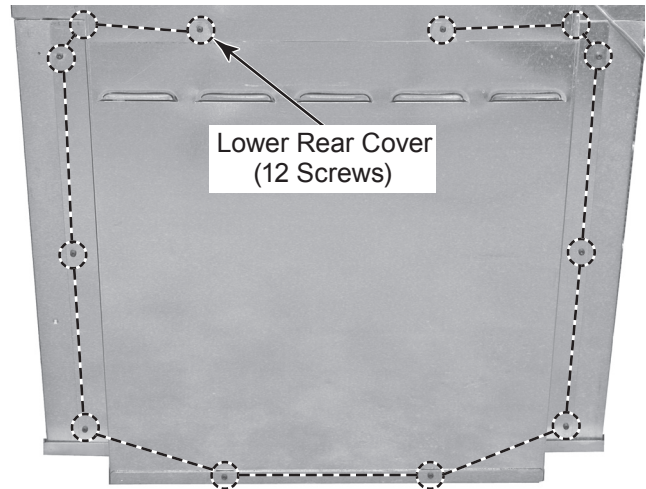

- e) Disconnect the sensor wire connector from the wiring harness.
- f) Push the sensor wire connector through the oven liner hole from the rear of the oven.

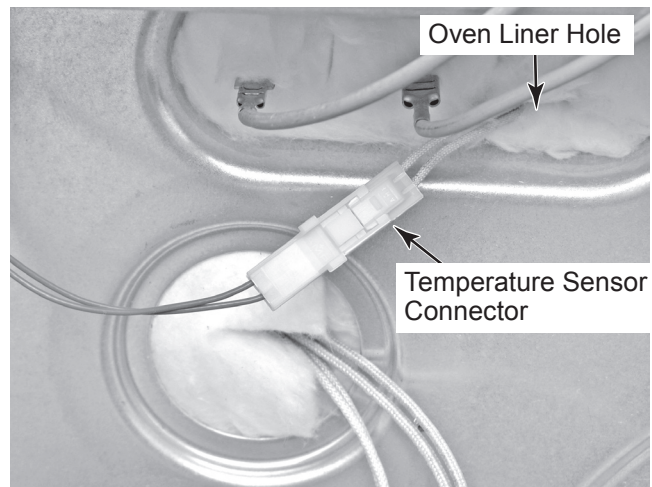

- g) Pull the temperature sensor connector out of the hole and remove the sensor.

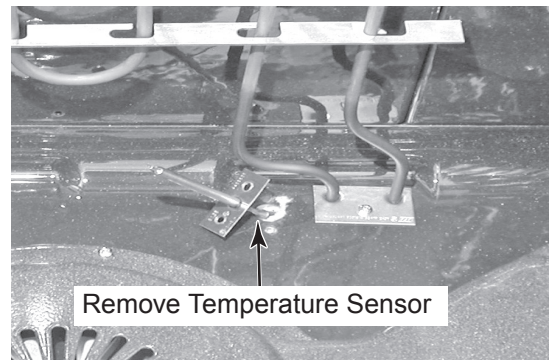

REMOVING THE LOWER CONVECTION RING ELEMENT AND CONVECTION FAN MOTOR

! WARNING



Electrical Shock Hazard
Disconnect power before servicing.
Replace all parts and panels before operating.
Failure to do so can result in death or electrical shock.

1. Unplug oven or disconnect power.
2. Open the lower oven door.
3. Remove the seven screws from the convection cover and remove the cover.

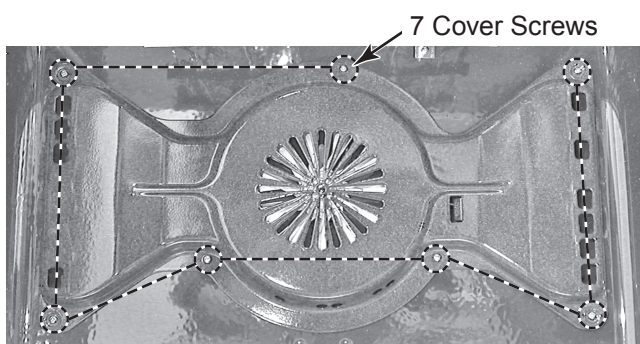
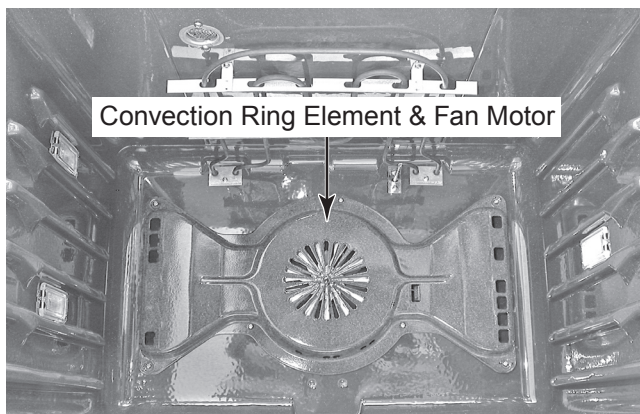

4. To remove the convection ring element:
 - a) Remove the two screws from the element brackets.

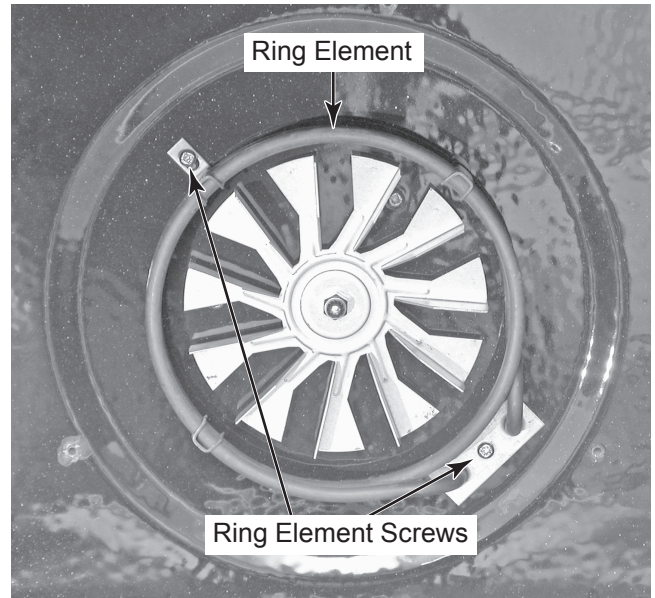

- b) Pull the convection ring element forward far enough to access the two wire connectors.
 - c) Disconnect the wire connectors from the convection ring element terminals and remove the element.

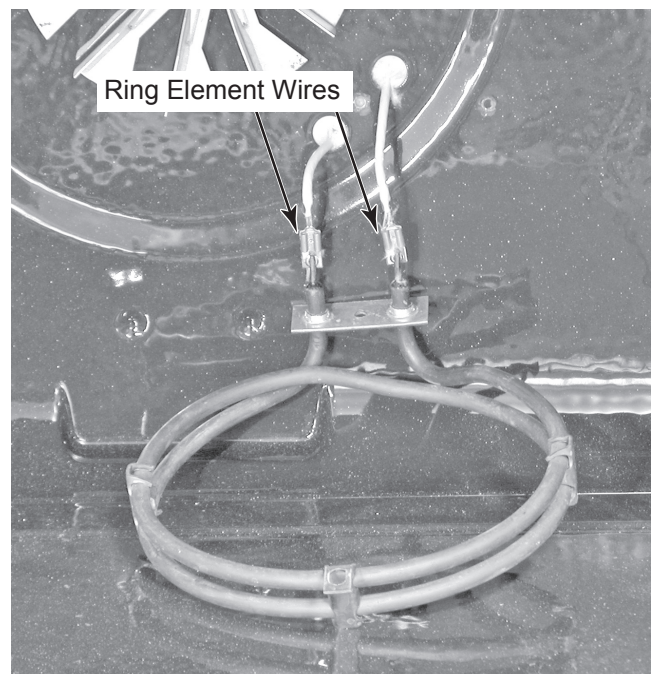

Continued on the next page.

5. To remove the convection fan motor:

- a) Remove the 10mm hex nut from the convection fan blade (left-hand rotation) and remove the blade from the motor shaft.

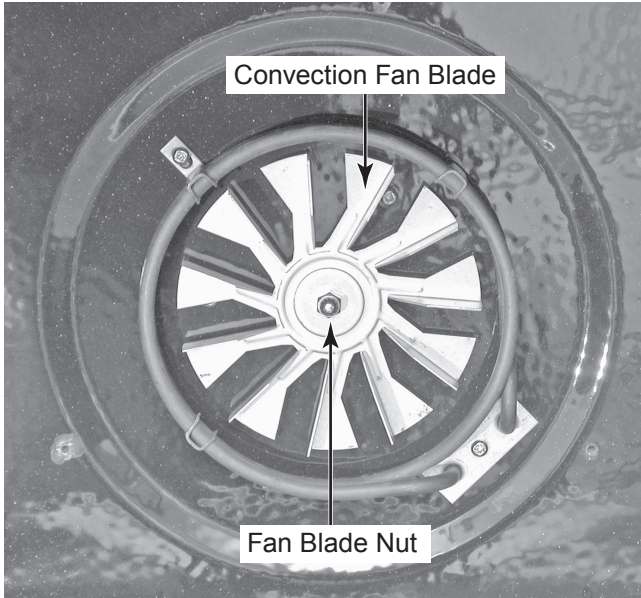

- b) Remove the three front screws from the convection fan motor.

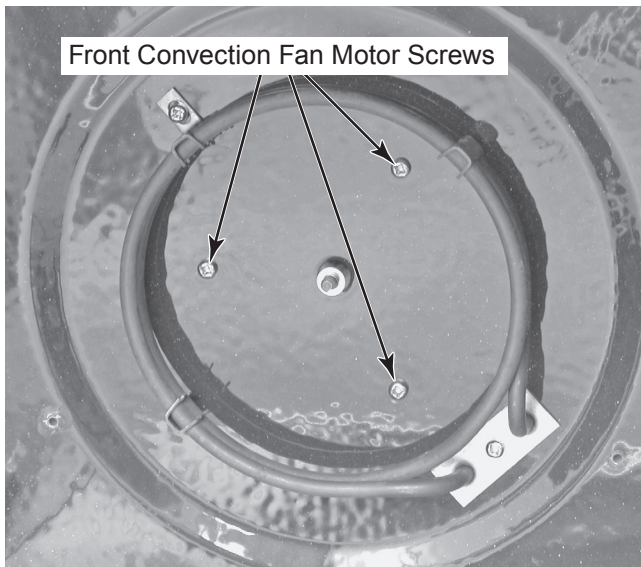

- c) Remove the oven from its mounting location (see "Installation Information" in Section 2) and pull it forward so that you can access the rear covers.

- d) Remove the twelve screws from the lower rear cover and remove the cover.

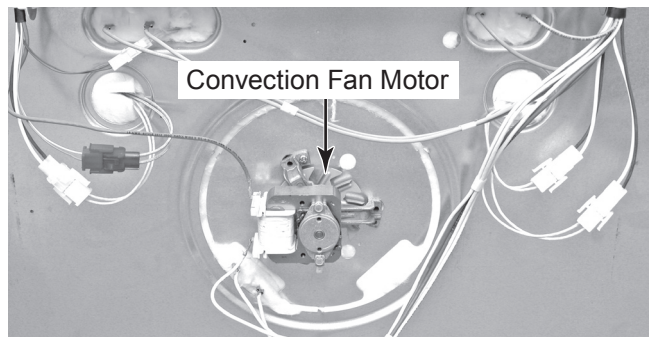
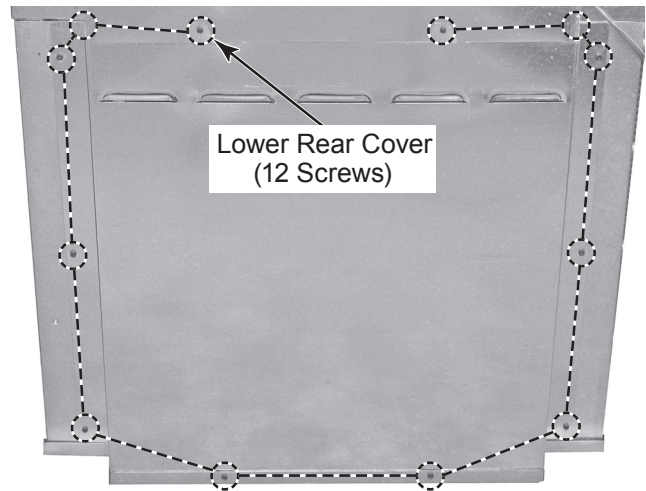

- e) Disconnect the red and yellow wires from the convection fan motor terminals.
- f) Remove the two screws from the fan motor and remove the motor.

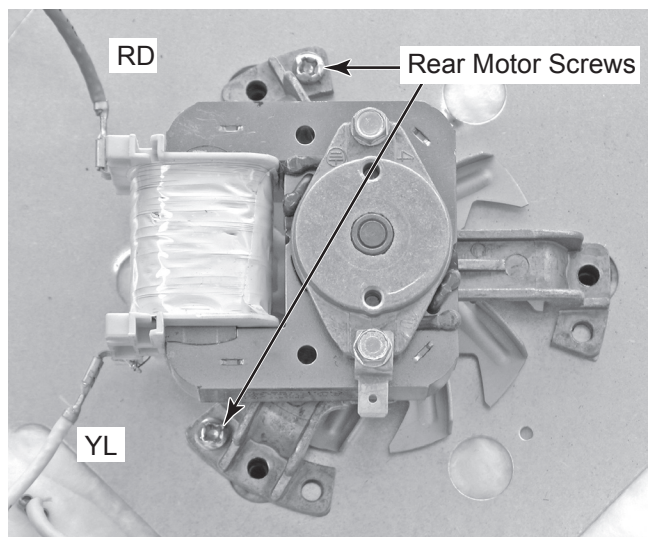

REMOVING LOWER HALOGEN LIGHT ASSEMBLY AND MEAT PROBE JACK

⚠ WARNING



Electrical Shock Hazard
Disconnect power before servicing.
Replace all parts and panels before operating.
Failure to do so can result in death or electrical shock.

1. Unplug oven or disconnect power.
2. Open the lower oven door.

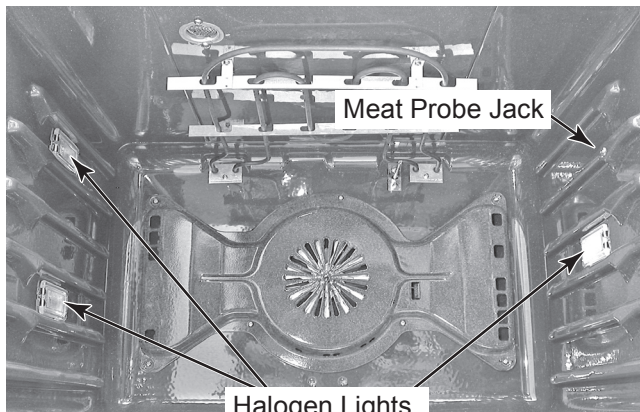

3. To remove a halogen light assembly:

- a) Remove the screw from the lens.

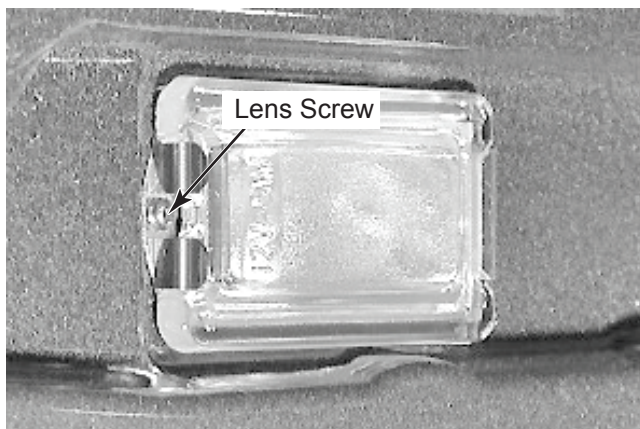

- b) Unclip the lens from the socket and remove the lens.

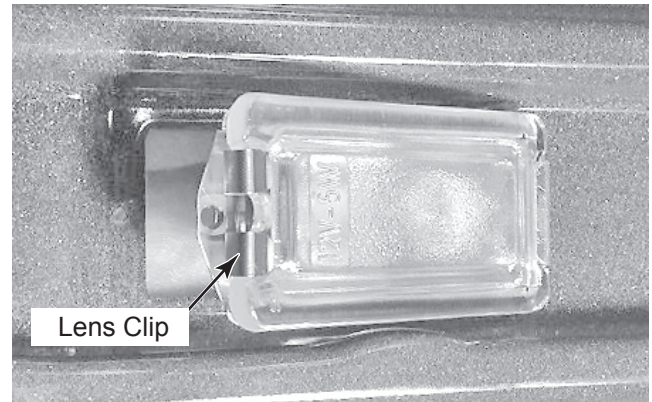

- c) Remove the halogen bulb from the socket connector.

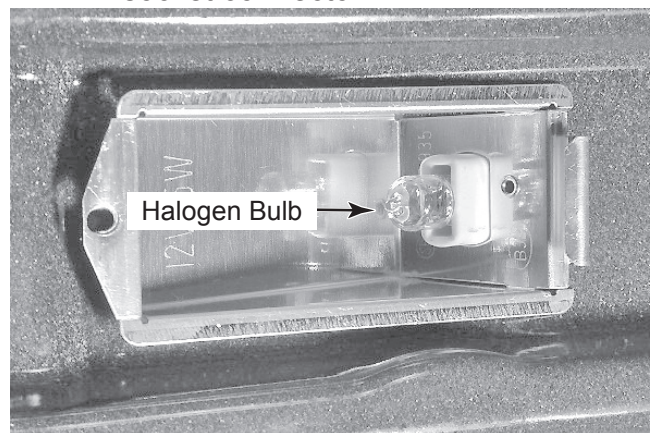

- d) Cut the wires near the socket body and splice the new socket in its place.

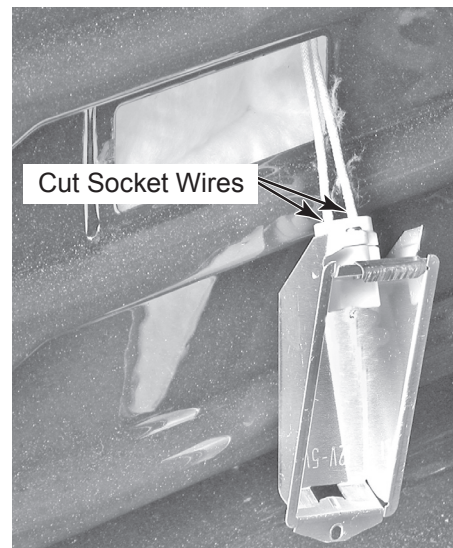

Continued on the next page.

4. To remove the meat probe jack:
- Remove the nut from the meat probe jack.

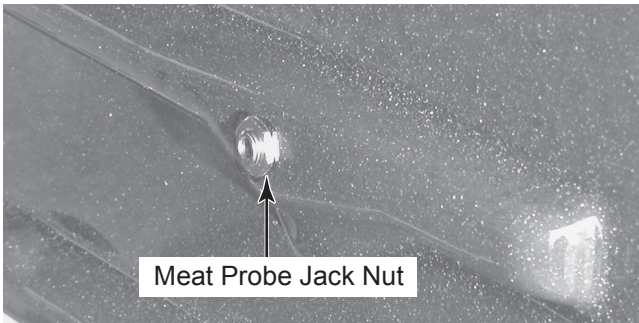

⚠ WARNING



Electrical Shock Hazard
Disconnect power before servicing.
Replace all parts and panels before operating.
Failure to do so can result in death or electrical shock.

- Remove the oven from its mounting location (see "Installation Information" in Section 2) and pull it forward so that you can access the meat probe jack access cover on the right side of the oven.

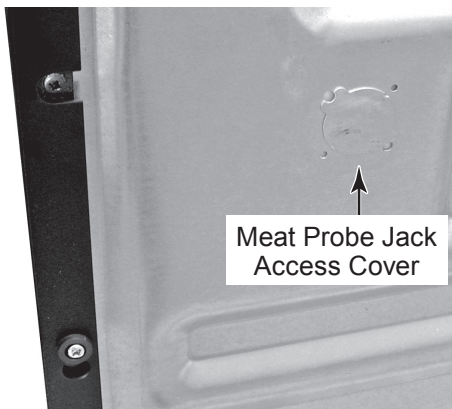

- Use a pair of side-cutters and cut the meat probe jack access cover from the right side cover (see the top right photo).



- Remove the meat probe jack from the right side cover.
- Disconnect the wires from the meat probe jack terminals. **NOTE:** Make sure that you reinstall the star washer on the new jack when you install it.

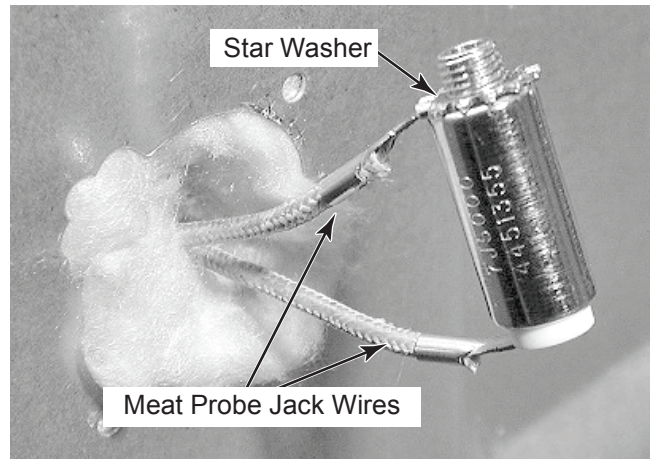

- Mount the meat probe jack access cover to the side cover with two screws.

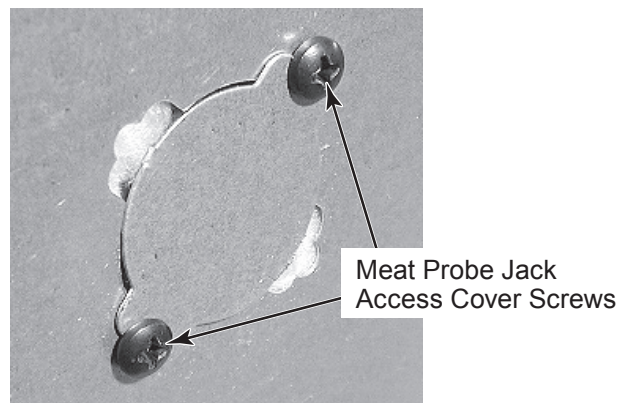

REMOVING LOWER BLOWER ASSEMBLY, BLOWER SPEED RESISTOR, AND OVEN THERMAL CUTOFF

⚠ WARNING



Electrical Shock Hazard

Disconnect power before servicing.

Replace all parts and panels before operating.

Failure to do so can result in death or electrical shock.

1. Unplug oven or disconnect power.

⚠ WARNING

Excessive Weight Hazard

Use two or more people to move and install oven.

Failure to do so can result in back or other injury.

2. Remove the oven from its mounting location (see “Installation Information” in Section 2) and pull it forward so that you can access the top cover.
3. Remove the six screws from the top cover and remove the cover.

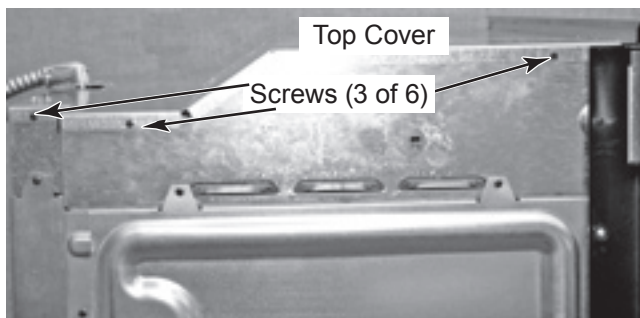

4. Remove the twelve screws from the upper rear cover of the oven and remove the cover.

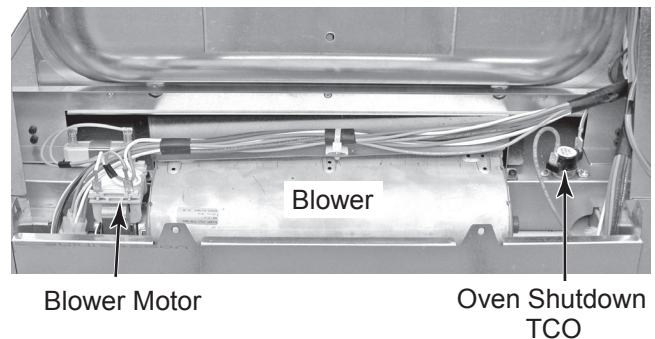
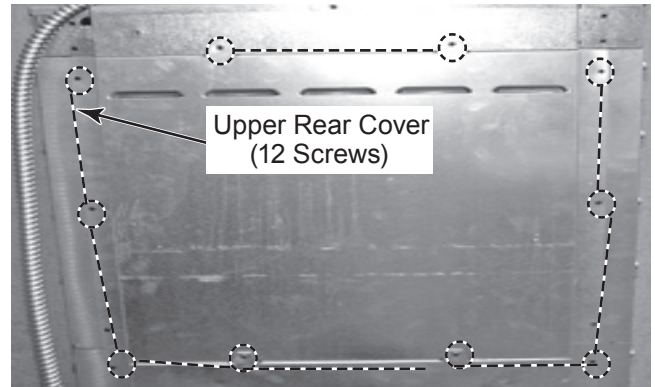

5. **To remove the blower assembly:**
 - a) Disconnect the white and gray wires from the blower motor terminals.
 - b) Remove the two screws from the blower brackets.
 - c) Pull back on the blower assembly while rotating it upwards and remove the assembly.

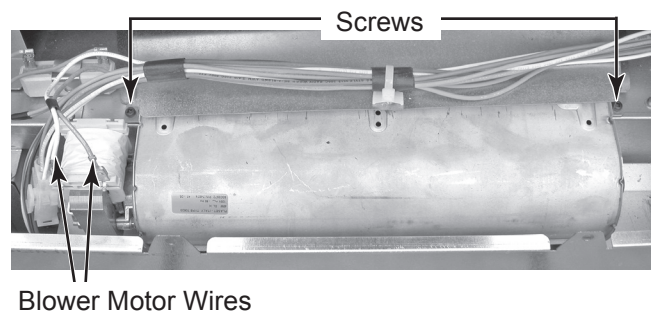

Continued on the next page.

6. To remove the blower speed resistor:

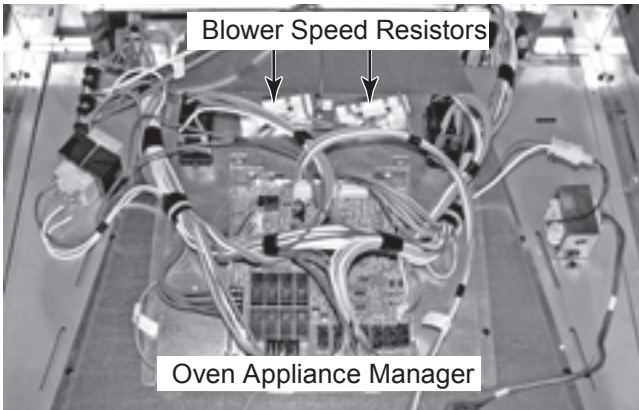

- a) Disconnect the two gray wires from the resistor terminals.
- b) Remove the screw from the resistor bracket and remove the resistor.

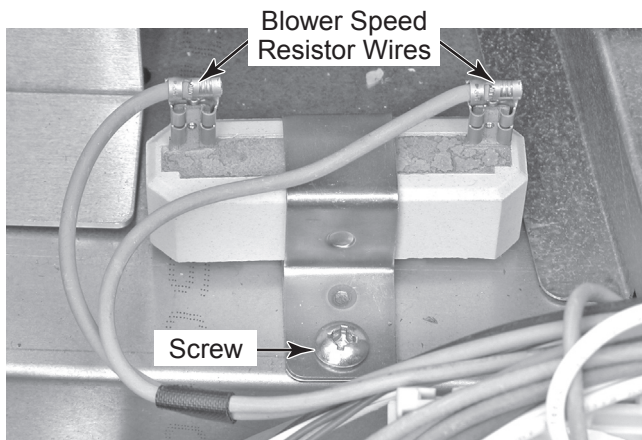

7. To remove the oven shutdown thermal cutoff (TCO):

- a) Remove the twelve screws from the upper rear cover and remove the cover.

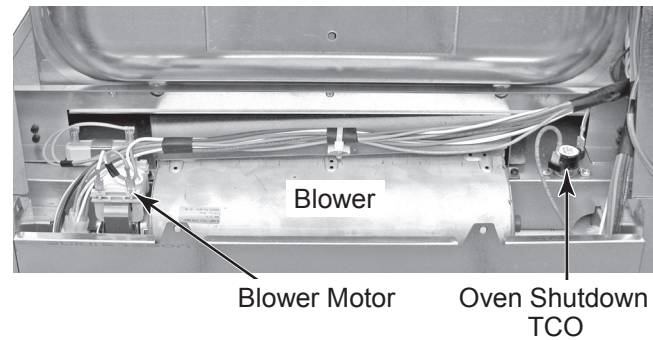
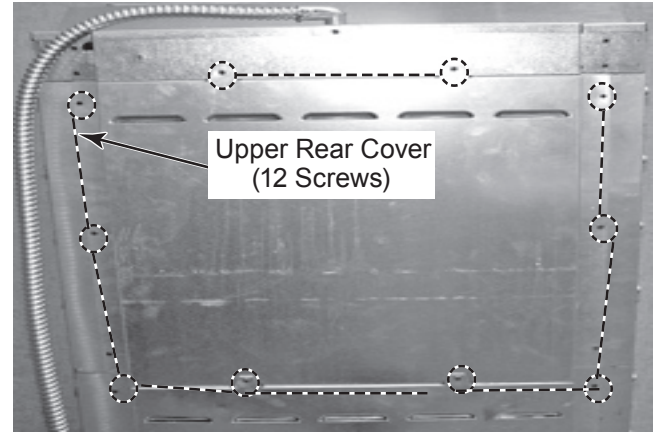

- b) Disconnect the two red wires from the TCO terminals.
- c) Remove the two mounting screws and remove the TCO.

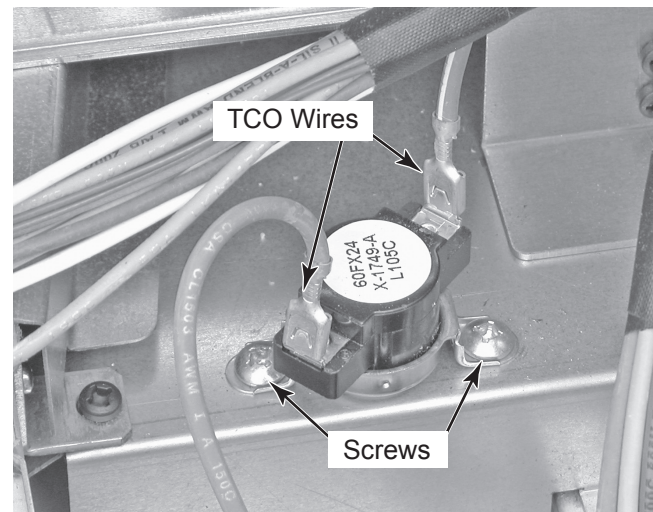

REMOVING THE LOWER HIDDEN BAKE ELEMENT

⚠ WARNING



Electrical Shock Hazard

**Disconnect power before servicing.
Replace all parts and panels before
operating.**

**Failure to do so can result in death or
electrical shock.**

1. Unplug oven or disconnect power.
2. Remove the oven from its mounting location (see “Installation Information” in Section 2) and pull it forward so that you can access the top cover.
3. Remove the six screws from the top cover and remove the cover.

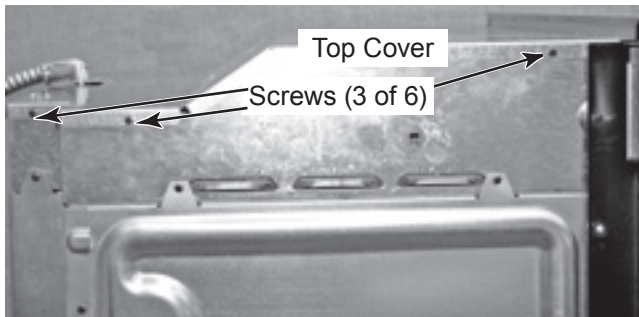

4. Remove the twelve screws from the lower rear cover and remove the cover.

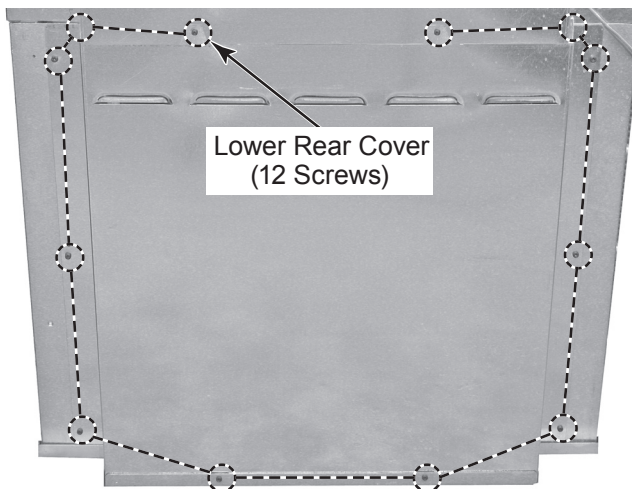

5. Disconnect the two red wires from the hidden bake element terminals.
6. Remove the four screws from the hidden bake element cover.

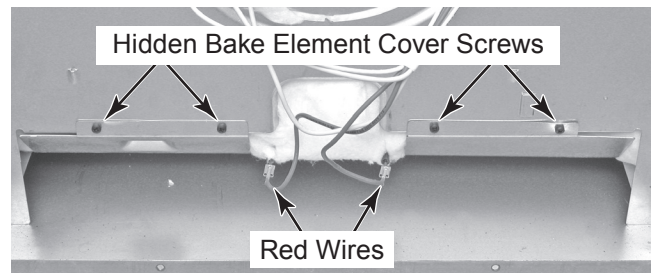

Continued on the next page.

7. Bend the hidden bake element cover flaps down as far as possible.
8. Using a single-edge razor blade, cut the insulation blanket along the bracket edge of the hidden bake element. Spread the blanket apart so you can access the bracket screws.

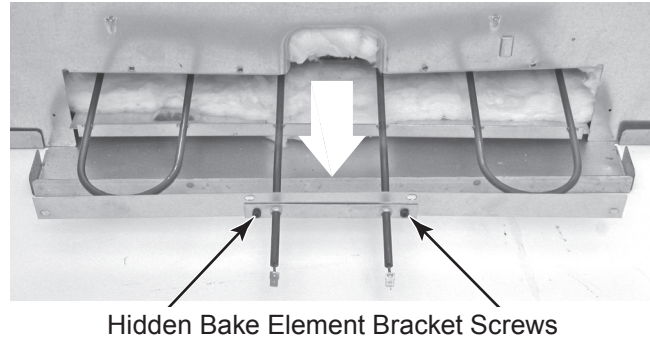
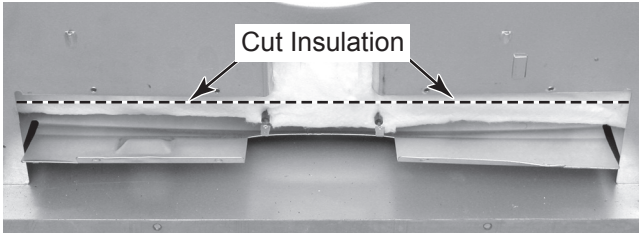

9. Remove the four screws from the hidden bake element bracket.

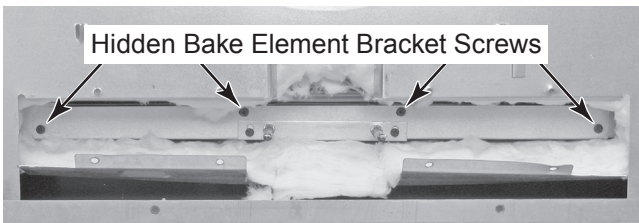

NOTE: When you remove the lower hidden bake element, press down on the front edge of the panel that is below the element so that it does not interfere with the removal.

10. Pull the lower hidden bake element out and remove it from the bottom of the oven.
11. Remove the two bracket screws from the hidden bake element and remove the bracket from the element.

REASSEMBLY NOTE: When you install the replacement hidden bake element, press down on the front edge of the panel that is below the element so that it does not interfere with the installation. When installed, the edge of the panel should be below the element bracket so that the bracket fits flush against the chassis.

REMOVING LOWER OVEN DOOR GLASS AND HANDLE

1. Open the lower oven door.
2. Raise the two door hinge tabs to the “un-locked” position.



3. Close the oven door to within several inches, lift and pull out on the hinges, and remove them from the oven slots.
4. Place the oven door front side down on a padded surface to protect the finish.
5. Remove the two screws from each of the bottom corner glass holders and remove the holders.
6. **To remove the inner oven door glass panels**, lift each of the three glass panels, and remove them from the door.

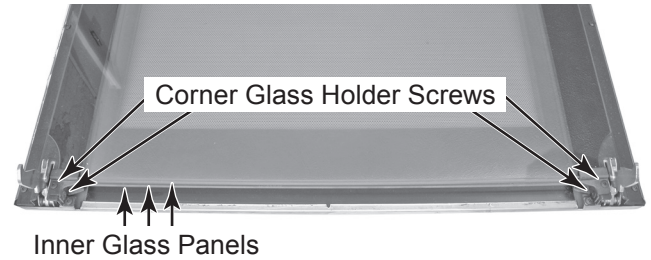

7. **To remove the door handle and outer oven door glass:**

- a) Remove the three inner glass panels (see step 6).
- b) Remove the three screws from the air vent and remove the vent.

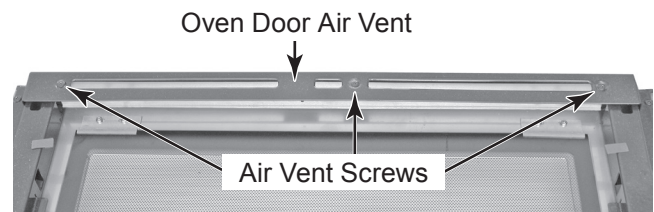

- c) Remove the four door handle bracket screws and remove the brackets and handle from the door.
- d) Slide the bottom edge of the outer oven door glass out of the door frame and remove the glass.

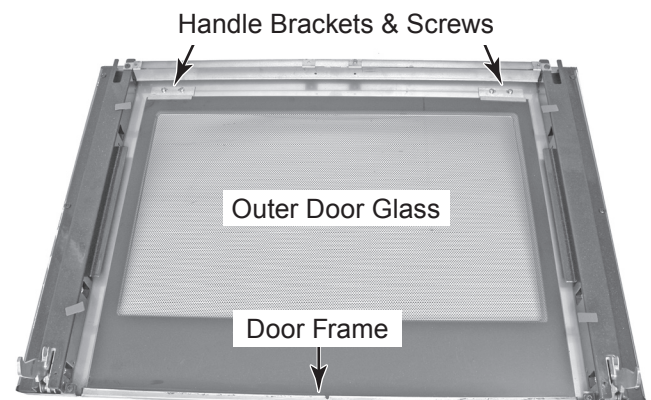

REMOVING LOWER OVEN DOOR GASKET

1. Remove the lower oven door (see the procedure on page 4-35).
2. Remove the screw from the door gasket retainer and remove the retainer.
3. Pull the door gasket clips out of the oven liner holes and remove the gasket.

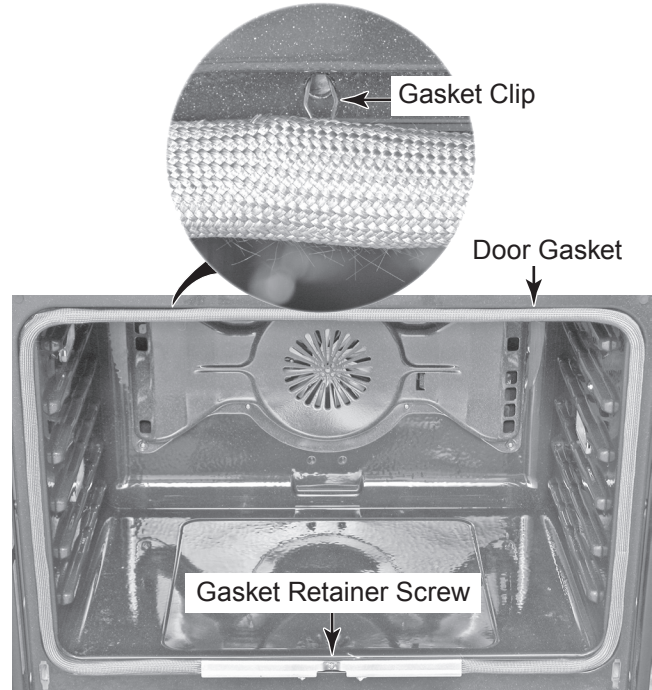

COMPONENT TESTING

UPPER OVEN COMPONENTS

Before testing any of the components, perform the following checks:

- The most common cause for control failure is corrosion on connectors. Therefore, disconnecting and reconnecting wires will be necessary throughout test procedures.
- All tests/checks should be made with a VOM or DVM having a sensitivity of 20,000 ohms-per-volt DC, or greater.
- Check all connections before replacing components, looking for broken or loose wires, failed terminals, or wires not pressed into connectors far enough.
- Voltage checks must be made with all connectors attached to the boards.
- Resistance checks must be made with power cord unplugged from outlet, and with wiring harness or connectors disconnected.



! WARNING

Electrical Shock Hazard

**Disconnect power before servicing.
Replace all parts and panels before operating.
Failure to do so can result in death or electrical shock.**

BLOWER MOTOR

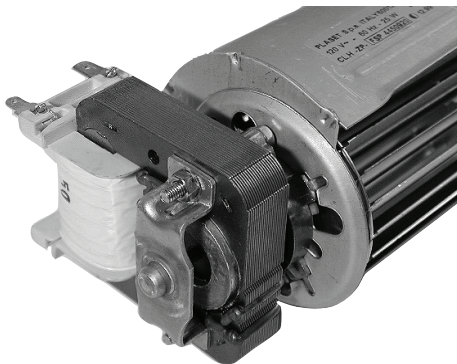

Refer to page 4-16 for the procedure for accessing the blower motor.

1. Unplug oven or disconnect power.
2. Set the ohmmeter to the R x 1 scale.
3. Touch the ohmmeter test leads across wire connector terminals. The meter should indicate between 181 and 240 Ω .

OVEN TEMPERATURE SENSOR



Refer to page 4-11 for the procedure for accessing the oven temperature sensor.

1. Unplug oven or disconnect power.
2. Set the ohmmeter to the R x 1K scale.
3. Touch the ohmmeter test leads across wire connector terminals. The meter should indicate approximately 1091 Ω @ 75°F (23.9°C).

⚠ WARNING



Electrical Shock Hazard

Disconnect power before servicing.
Replace all parts and panels before operating.
Failure to do so can result in death or electrical shock.

CONVECTION RING ELEMENT



Refer to page 4-12 for the procedure for accessing the convection ring element.

1. Unplug oven or disconnect power.
2. Set the ohmmeter to the R x 1 scale.
3. Touch the ohmmeter test leads across wire connector terminals. The meter should indicate between 33 and 37 Ω .

CONVECTION FAN MOTOR

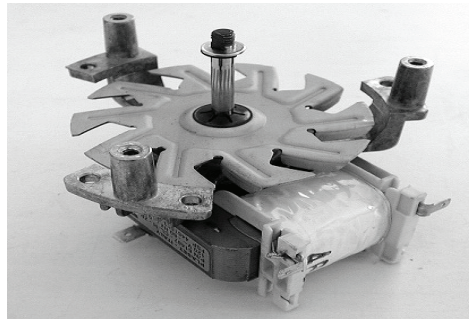

Refer to page 4-13 for the procedure for accessing the convection fan motor.

1. Unplug oven or disconnect power.
2. Set the ohmmeter to the R x 1 scale.
3. Touch the ohmmeter test leads across wire connector terminals. The meter should indicate approximately 18 Ω .



! WARNING

Electrical Shock Hazard

Disconnect power before servicing.
Replace all parts and panels before operating.
Failure to do so can result in death or electrical shock.

BROIL ELEMENT

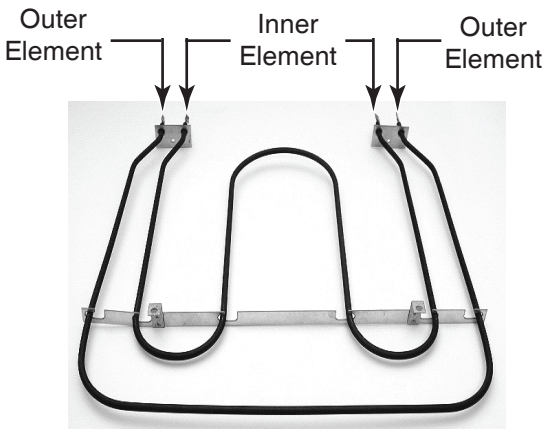

Refer to page 4-10 for the procedure for accessing the broil element.

1. Unplug oven or disconnect power.
2. Set the ohmmeter to the R x 1 scale.
3. Touch the ohmmeter test leads across the wire connector terminals. The meter should indicate as shown below:

Inner Element: The meter should indicate between 31 and 36 Ω .

Outer Element: The meter should indicate between 53 and 59 Ω .

HIDDEN BAKE ELEMENT

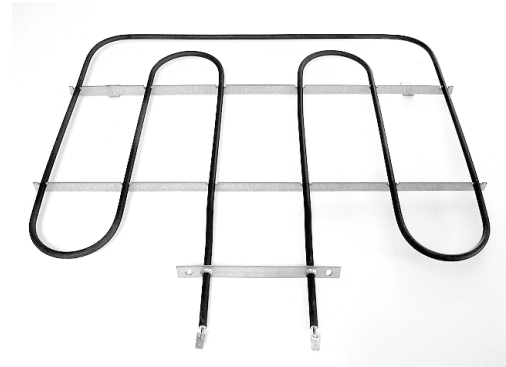

Refer to page 4-18 for the procedure for accessing the hidden bake element.

1. Unplug oven or disconnect power.
2. Set the ohmmeter to the R x 1 scale.
3. Touch the ohmmeter test leads across wire connector terminals. The meter should indicate between 26 and 30 Ω .

! WARNING



Electrical Shock Hazard

Disconnect power before servicing.
Replace all parts and panels before operating.
Failure to do so can result in death or electrical shock.

DOOR LATCH ASSEMBLY

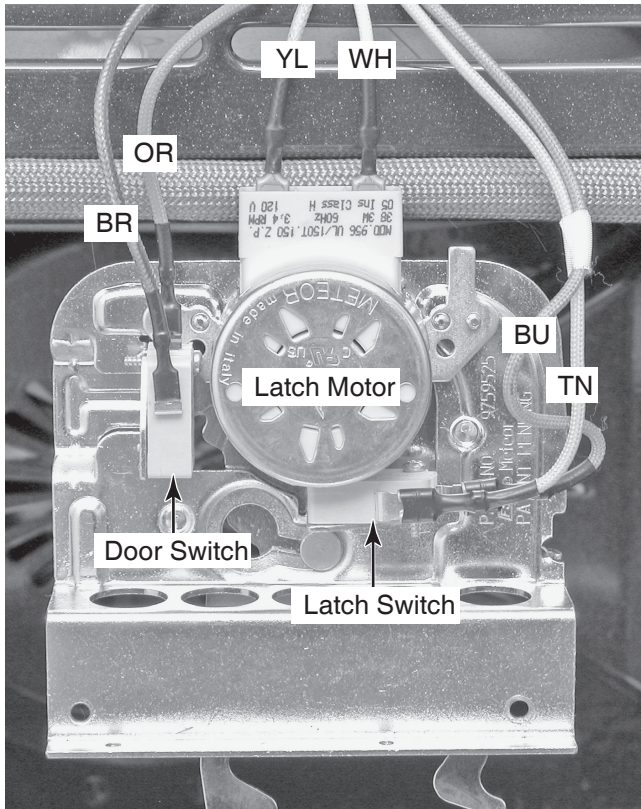

Refer to page 4-7 for the procedure for accessing the door latch assembly.

1. Unplug oven or disconnect power.
2. Set the ohmmeter to the R x 1K scale.
3. Touch the ohmmeter test leads to the wire connector terminals. The meter should indicate as shown below:

Latch Switch: (BU) and (TN). The meter should indicate an open circuit (infinite) with door unlocked, and a closed circuit (0Ω) with the door locked.

Door Switch: (OR) and (BR). The meter should indicate an open circuit (infinite) with door unlocked, and a closed circuit (0Ω) with the door locked.

Latch Motor: (YL) and the neutral (WH) terminal. The meter should indicate approximately 2450Ω .



⚠ WARNING

Electrical Shock Hazard

Disconnect power before servicing.
Replace all parts and panels before operating.
Failure to do so can result in death or electrical shock.

OVEN SHUTDOWN THERMAL CUTOFF (TCO)

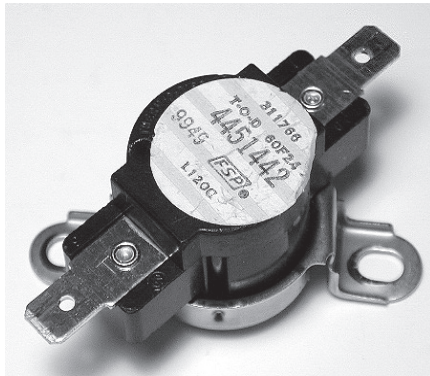

Refer to page 4-17 for the procedure for accessing the oven shutdown thermal cutoff.

1. Unplug oven or disconnect power.
2. Set the ohmmeter to the R x 1 scale.
3. Touch the ohmmeter test leads across wire connector terminals. The meter should indicate a closed circuit (0 Ω).

OVEN LIGHT TRANSFORMER

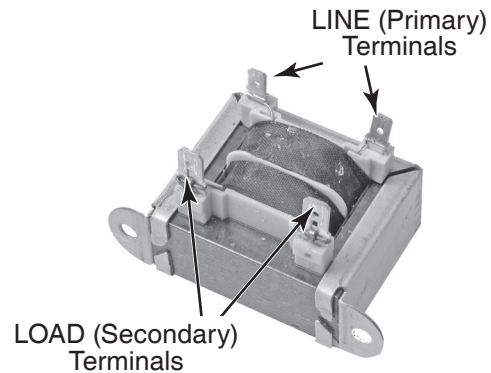

Refer to page 4-5 for the procedure for accessing the oven light transformer.

1. Unplug oven or disconnect power.
2. Disconnect one of the wires from the LINE (primary) and one from the LOAD (secondary) terminals.
3. Set the ohmmeter to the R x 1 scale.
4. Touch the ohmmeter test leads to the LINE terminals. The meter should indicate approximately 40 to 45 Ω .
5. Touch the ohmmeter test leads to the LOAD terminals. The meter should indicate less than 1 Ω .

! WARNING

Electrical Shock Hazard

Disconnect power before servicing.
Replace all parts and panels before operating.
Failure to do so can result in death or electrical shock.



MEAT PROBE JACK

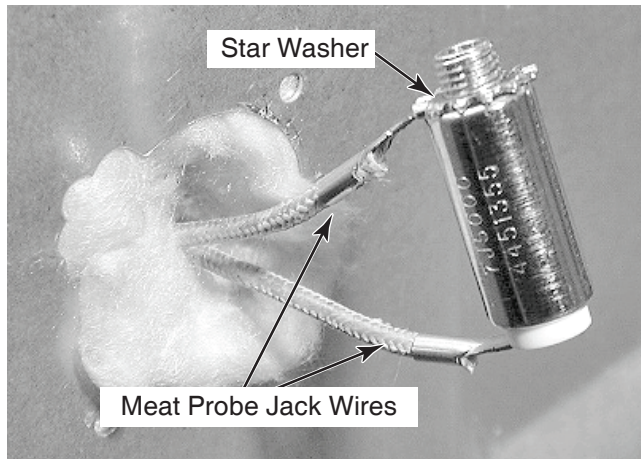

Refer to page 4-15 for the procedure for accessing the meat probe jack.

1. Unplug oven or disconnect power.
2. Set the ohmmeter to the R x 1 scale.
3. Touch the ohmmeter test leads across wire connector terminals. The meter should indicate approximately 78 Ω @ 60°F (15.6°C).

BLOWER SPEED RESISTOR

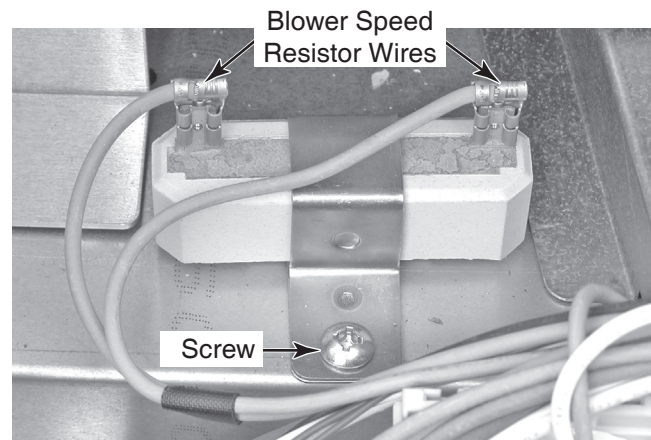

Refer to page 4-16 for the procedure for accessing the blower speed resistor.

1. Unplug oven or disconnect power.
2. Set the ohmmeter to the R x 1 scale.
3. Touch the ohmmeter test leads across wire connector terminals. The meter should indicate approximately 170 Ω .

LOWER OVEN COMPONENTS



! WARNING

Electrical Shock Hazard

Disconnect power before servicing.

Replace all parts and panels before operating.

Failure to do so can result in death or electrical shock.

DOOR LATCH ASSEMBLY

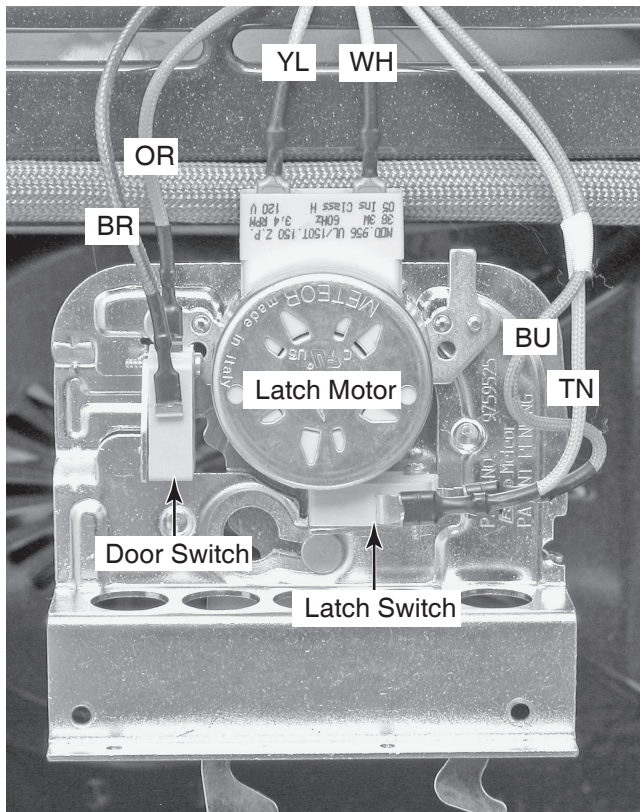

Refer to page 4-24 for the procedure for accessing the door latch assembly.

1. Unplug oven or disconnect power.
2. Set the ohmmeter to the R x 1K scale.
3. Touch the ohmmeter test leads to the wire connectors. The meter should indicate as shown below:

Latch Switch: (BU) and (TN). The meter should indicate an open circuit (infinite) with door unlocked, and a closed circuit (0 Ω) with the door locked.

Door Switch: (OR) and (BR). The meter should indicate an open circuit (infinite) with door unlocked, and a closed circuit (0 Ω) with the door locked.

Latch Motor: (YL) and the neutral (WH) stud on the AC terminal block. The meter should indicate approximately 2450 Ω .



! WARNING

Electrical Shock Hazard

Disconnect power before servicing.
Replace all parts and panels before operating.
Failure to do so can result in death or electrical shock.

BROIL ELEMENT

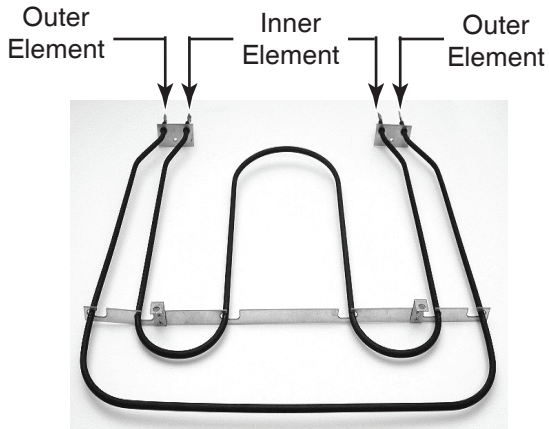

Refer to page 4-27 for the procedure for accessing the broil element.

1. Unplug oven or disconnect power.
2. Set the ohmmeter to the R x 1 scale.
3. Touch the ohmmeter test leads across the wire connector terminals. The meter should indicate as shown below:

Inner Element: The meter should indicate between 31 and 36 Ω .

Outer Element: The meter should indicate between 53 and 59 Ω .

OVEN TEMPERATURE SENSOR



Refer to page 4-28 for the procedure for accessing the oven temperature sensor.

1. Unplug oven or disconnect power.
2. Set the ohmmeter to the R x 1K scale.
3. Touch the ohmmeter test leads across the wire connector terminals. The meter should indicate approximately 1091 Ω @ 75°F (23.9°C).



! WARNING

Electrical Shock Hazard

**Disconnect power before servicing.
Replace all parts and panels before operating.
Failure to do so can result in death or electrical shock.**

CONVECTION RING ELEMENT

CONVECTION FAN MOTOR

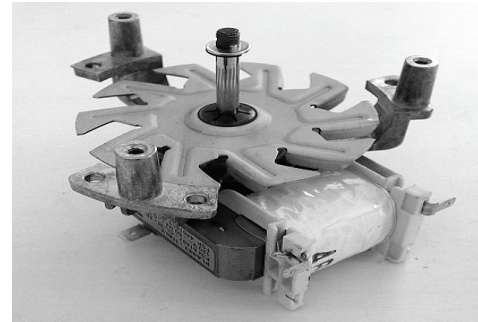
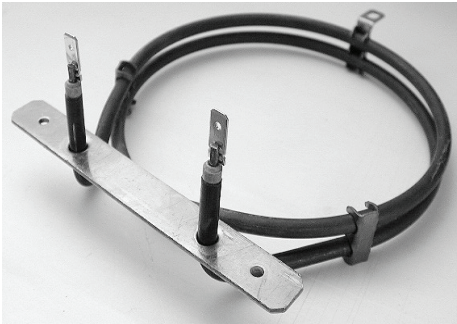

Refer to page 4-29 for the procedure for accessing the convection ring element.

1. Unplug oven or disconnect power.
2. Set the ohmmeter to the R x 1 scale.
3. Touch the ohmmeter test leads across the wire connector terminals. The meter should indicate between 33 and 37 Ω .

Refer to page 4-30 for the procedure for accessing the convection fan motor.

1. Unplug oven or disconnect power.
2. Set the ohmmeter to the R x 1 scale.
3. Touch the ohmmeter test leads across the wire connector terminals. The meter should indicate approximately 18 Ω .

⚠ WARNING



Electrical Shock Hazard

Disconnect power before servicing.
Replace all parts and panels before operating.
Failure to do so can result in death or electrical shock.

MEAT PROBE JACK

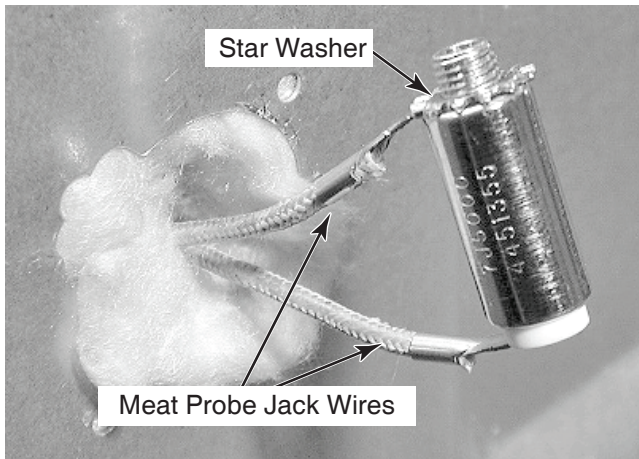

Refer to page 4-32 for the procedure for accessing the meat probe jack.

1. Unplug oven or disconnect power.
2. Set the ohmmeter to the R x 1 scale.
3. Touch the ohmmeter test leads across the wire connector terminals. The meter should indicate approximately 78Ω @ 60°F (15.6°C).

BLOWER MOTOR

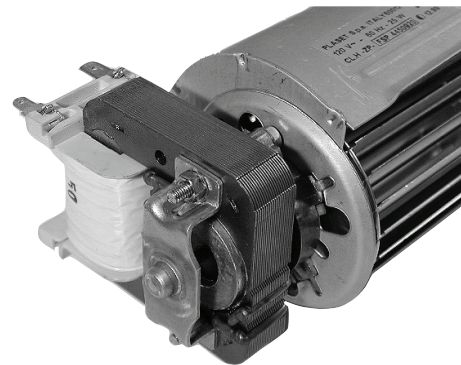

Refer to page 4-33 for the procedure for accessing the blower motor.

1. Unplug oven or disconnect power.
2. Set the ohmmeter to the R x 1 scale.
3. Touch the ohmmeter test leads across the wire connector terminals. The meter should indicate between 181 and 240Ω .



⚠ WARNING

Electrical Shock Hazard

Disconnect power before servicing.
Replace all parts and panels before operating.
Failure to do so can result in death or electrical shock.

BLOWER SPEED RESISTOR

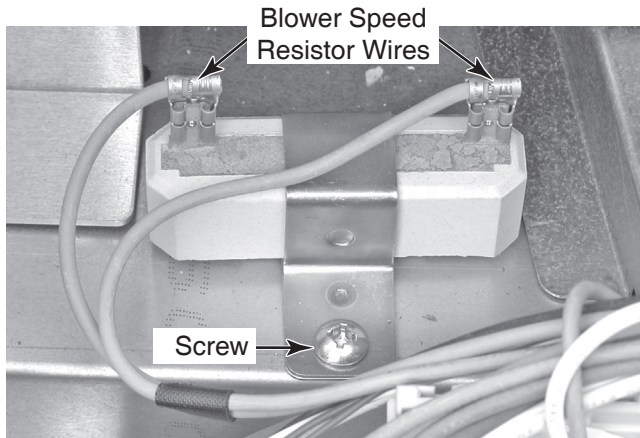

Refer to page 4-33 for the procedure for accessing the blower speed resistor.

1. Unplug oven or disconnect power.
2. Set the ohmmeter to the R x 1 scale.
3. Touch the ohmmeter test leads across the wire connector terminals. The meter should indicate approximately 170 Ω .

OVEN SHUTDOWN THERMAL CUTOFF (TCO)

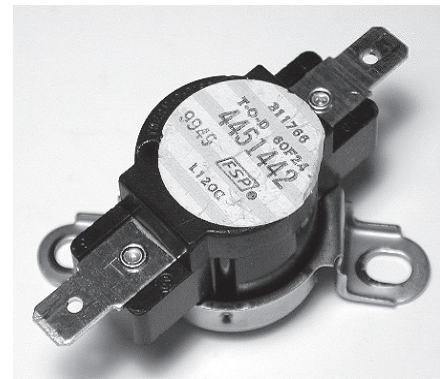

Refer to page 4-34 for the procedure for accessing the oven shutdown thermal cutoff.

1. Unplug oven or disconnect power.
2. Set the ohmmeter to the R x 1 scale.
3. Touch the ohmmeter test leads across the wire connector terminals. The meter should indicate a closed circuit (0 Ω).

! WARNING



Electrical Shock Hazard

Disconnect power before servicing.

Replace all parts and panels before operating.

Failure to do so can result in death or electrical shock.

HIDDEN BAKE ELEMENT

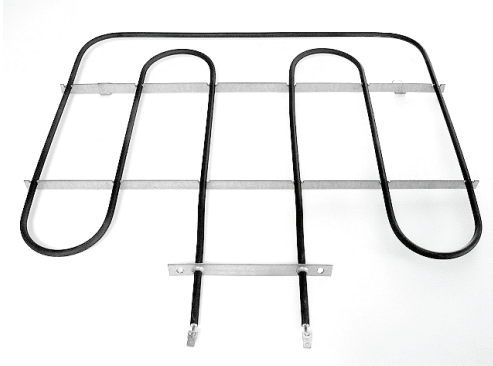

Refer to page 4-35 for the procedure for accessing the hidden bake element.

1. Unplug oven or disconnect power.
2. Set the ohmmeter to the R x 1 scale.
3. Touch the ohmmeter test leads across the wire connector terminals. The meter should indicate between 26 and 30 Ω .

DIAGNOSTICS & TROUBLESHOOTING



⚠ WARNING

Electrical Shock Hazard

Disconnect power before servicing.

Replace all parts and panels before operating.

Failure to do so can result in death or electrical shock.

IMPORTANT

Electrostatic Discharge (ESD) Sensitive Electronics

ESD problems are present everywhere. ESD may damage or weaken the electronic control assembly. The new control assembly may appear to work well after repair is finished, but failure may occur at a later date due to ESD stress.

- Use an anti-static wrist strap. Connect wrist strap to green ground connection point or unpainted metal in the appliance.

-OR-

Touch your finger repeatedly to a green ground connection point or unpainted metal in the appliance.

- Before removing the part from its package, touch the anti-static bag to a green ground connection point or unpainted metal in the appliance.
- Avoid touching electronic parts or terminal contacts; handle electronic control assembly by edges only.
- When repackaging failed electronic control assembly in anti-static bag, observe above instructions.

DIAGNOSTICS

- Is oven in “Sabbath Mode”? If so “SAB” will appear in the digital display. Press OPTIONS and “7” to end Sabbath mode. This will return to BAKE mode for an untimed bake.

Disconnect power and perform the following checks:

- A potential cause of a control not functioning is corrosion on connections. Observe connections and check for continuity with an ohmmeter.
- All tests/checks should be made with a VOM or DVM having a sensitivity of 20,000 ohms per volt DC or greater.
- Check all connections before replacing components, looking for broken or loose wires, failed terminals, or wires not pressed into connectors far enough. Damaged harness must be entirely replaced. Do not re-work a harness.
- Voltage checks must be made with all connectors attached to the boards.
- Resistance checks must be made with power cord unplugged from outlet, and with wiring harness or connectors disconnected.

FAILURE / ERROR DISPLAY CODES

Before proceeding with any corrective action, perform the following steps to enter the Diagnostic mode.

1. Press the OFF key.
2. Press the OFF key.
3. Press the START key. If control does not enter Diagnostics, repeat steps.

Screen 1:

- A. Main clock hours display shows latch state in first display position, and door state in second position. Upper cavity is displayed. To display lower cavity, press lower oven key.
- B. Main clock minutes display show the model select state associated with control system.
- C. Main temperature display shows the cavity temperature.
- D. Lower text line shows software versions for appliance manager (AM), user interface (UI) and EEPROM version.

Press key #6 to scroll to next screen.

Screen 2:

Screen displays programmed cavity size. Press key #6 to scroll to next screen.

Screen 3:

Displays the last error code in memory. If GOOD is displayed there is not an error coded in memory.

To Clear Last Error Code

- A. Unplug oven or disconnect power.
- B. Wait 10 seconds, reconnect or plug in oven.
- C. Enter Diagnostics mode by pressing OFF, OFF, START.
- D. Press key #6 to show cavity size select screen.
- E. Press key #6 to show error code.
- F. To edit press CLOCK key
- G. Press START key to clear last error. Control should display GOOD.

Troubleshooting Key strokes

- Press the Bake key activates Bake relay.
- Press Broil key once to activate Outer Broil, press again for Inner Broil.
- Press Convection Bake key activates Convection Ring and Fan.
- Press Self Clean key activates Latch Motor.
- Press Cook time key once to activate low speed, press again for high speed.

FAILURE (Leftmost 2 Clock Digits)	ERROR (Rightmost 2 Clock Digits)	MESSAGE/DESCRIPTION
		SUGGESTED CORRECTIVE ACTION PROCEDURE
F0 Default	E0	NO FAILURE (GOOD)
F1 Internal	E0	CHECK OVEN USER INTERFACE
<p>PROCEDURE: Before proceeding, press OFF, OFF, START to enter the Diagnostic mode and verify the error codes.</p> <p>A. Unplug oven or disconnect power.</p> <p>B. Replace oven user interface board.</p> <p>C. Replace all parts and panels before operating.</p> <p>D. Plug in oven or reconnect power.</p> <p>E. Verify operation is normal. Press OFF, OFF, START to reenter the Diagnostic mode and complete checks.</p>		
FAILURE (Leftmost 2 Clock Digits)	ERROR (Rightmost 2 Clock Digits)	MESSAGE/DESCRIPTION
		SUGGESTED CORRECTIVE ACTION PROCEDURE
F1 Internal	E1	CHECK OVEN APPLIANCE MANAGER
<p>PROCEDURE: Before proceeding, press OFF, OFF, START to enter the Diagnostic mode and verify the error codes.</p> <p>A. Unplug oven or disconnect power.</p> <p>B. Check oven door switch. If OK, go to step C.</p> <p>C. Replace oven appliance manager.</p> <p>D. Replace all parts and panels before operating.</p> <p>E. Plug in oven or reconnect power.</p> <p>F. Verify operation is normal. Press OFF, OFF, START to reenter the Diagnostic mode and complete checks.</p>		



⚠ WARNING

Electrical Shock Hazard

Disconnect power before servicing.
Replace all parts and panels before operating.
Failure to do so can result in death or electrical shock.

FAILURE (Leftmost 2 Clock Digits)	ERROR (Rightmost 2 Clock Digits)	MESSAGE/DESCRIPTION
SUGGESTED CORRECTIVE ACTION PROCEDURE		
F2 Keypad	E0 E1	KEYPAD DISCONNECTED STUCK OR SHORTED KEY
<p>PROCEDURE: Before proceeding, press OFF, OFF, START to enter the Diagnostic mode and verify the error codes.</p> <p>A. Unplug oven or disconnect power.</p> <p>B. Check keypad connector for firm connection.</p> <p>C. Replace all parts and panels before operating.</p> <p>D. Plug in range or reconnect power.</p> <p>E. If error code returns after 60 seconds proceed to step F.</p> <p>F. Unplug oven or disconnect power.</p> <p>G. Replace keypad.</p> <p>H. Replace all parts and panels before operating.</p> <p>I. Plug in oven or reconnect power. Wait 60 seconds.</p> <p>J. If error code returns after 60 seconds, proceed to step K.</p> <p>K. Unplug oven or disconnect power.</p> <p>L. Replace cable connecting user interface and keypad.</p> <p>M. Replace all parts and panels before operating.</p> <p>N. Plug in oven or reconnect power. Wait 60 seconds.</p> <p>O. If error code returns after 60 seconds, proceed to step P.</p> <p>P. Unplug oven or disconnect power.</p> <p>Q. Replace oven user interface.</p> <p>R. Replace all parts and panels before operating.</p> <p>S. Plug in oven or reconnect power. Wait 60 seconds.</p> <p>T. Verify operation is normal. Press OFF, OFF, START to reenter the Diagnostic mode and complete checks.</p>		
F3 Sensors	E0 E1 E3	UPPER OVEN SENSOR SHORTED OR OPEN LOWER OVEN SENSOR SHORTED OR OPEN MEAT PROBE SHORTED
<p>PROCEDURE: Before proceeding, press OFF, OFF, START to enter the Diagnostic mode and verify the error codes.</p> <p>A. Verify in Diagnostics temperature reading on sensor.</p> <p>B. If dashes appear in main temperature display proceed to step C.</p> <p>C. Unplug oven or disconnect power.</p> <p>D. Remove back panels and ensure the indicated temperature sensor is plugged in properly and fully inserted. If not, plug in the connector and proceed to step E. If sensor is plugged in properly proceed to step E.</p> <p>E. Check connector P2 on the appliance manager. Ensure P2 connector is plugged in properly and fully inserted. If connector is inserted properly go to step J. If not proceed to step F.</p> <p>F. Visually inspect the wires between P2 on the appliance manager and the indicated temperature sensor. Make sure the wires are not pinched or cut. If wires appear intact, unplug P2 connector on the appliance manager. Go to step G.</p> <p>G. Measure the indicated sensor resistance value (measure between appropriate P2 connector pins). For the following sensors, the resistance value should read:</p> <p>Upper Oven Sensor Between 931 and 2869 Ω. (Approx. 1080 Ω at room temp.)</p> <p>Lower Oven Sensor Between 931 and 2869 Ω. (Approx. 1080 Ω at room temp.)</p> <p>Meat Probe Sensor Between 1,300 and 103,000 Ω.</p>		

FAILURE (Leftmost 2 Clock Digits)	ERROR (Rightmost 2 Clock Digits)	MESSAGE/DESCRIPTION
SUGGESTED CORRECTIVE ACTION PROCEDURE		
<p>H. For UPPER and LOWER sensors: Replace appropriate temperature sensor. Repeat step G. If the requirements are not met, replace sensor harness. Repeat step G.</p> <p>For MEAT PROBE SENSOR: Replace meat probe sensor, repeat step G. If the requirements are not met, replace sensor harness. Repeat step G. If the requirements are still not met, replace the meat probe jack. Repeat step G. If the meat probe sensor is still not operating correctly go to step I.</p> <p>I. Replace the appliance manager. Ensure all connectors are properly placed and firmly connected.</p> <p>J. Replace all parts and panels before operating.</p> <p>K. Plug in oven or reconnect power. Wait 60 seconds.</p> <p>L. Enter into Diagnostic mode and read sensor for upper oven sensor and meat probe on immediate display.</p>		
F3 Sensors	E2	WARMING DRAWER SENSOR SHORTED OR OPEN
<p>PROCEDURE: Oven is not equipped with this feature. If error occurs press OFF, OFF, START to enter into Diagnostic mode and verify the error codes. If error code returns, replace user interface with correct control associated with this product.</p>		
F5	E0 E1	DOOR AND LATCH SWITCH DO NOT AGREE DOOR LATCH NOT OPERATING.
<p>PROCEDURE: Before proceeding, press OFF, OFF, START to enter the Diagnostic mode and verify the error codes.</p> <p>TO VERIFY DOOR SWITCH:</p> <p>A. While in diagnostics, open the oven door. The second digit on the clock display should toggle between "1" and "0" as the door opens and closes. When door is closed display should show "1", when the door is open display should show "0". If the second digit on the clock display did not toggle, go to step B. If the digit did not toggle after replacing the door switch, go to step D. If the digit did not toggle after replacing the door switch harness, go to step F.</p> <p>B. Unplug oven or disconnect power.</p> <p>C. Replace door switch. (If door switch is integral to the door latch motor assembly, replace the entire door/latch motor assembly). Go to step H.</p> <p>D. Unplug oven or disconnect power.</p> <p>E. Check the integrity of the harness wires and connections between the appliance manager and the door/latch assembly. Ensure there are no shorted or pinched wires. If the wiring harness is pinched or damaged, replace the door switch harness. Go to step H. If wiring harness is good, go to step H.</p> <p>F. Unplug oven or disconnect power.</p> <p>G. Replace appliance manager. Go to step H.</p> <p>H. Replace all parts and panels before operating.</p> <p>I. Plug in oven or reconnect power.</p> <p>J. Press OFF, OFF, START to reenter the Diagnostic mode and complete checks. Repeat step A.</p>		

FAILURE (Leftmost 2 Clock Digits)	ERROR (Rightmost 2 Clock Digits)	MESSAGE/DESCRIPTION
		SUGGESTED CORRECTIVE ACTION PROCEDURE
TO VERIFY DOOR LATCH SWITCH/MOTOR ASSEMBLY:		
<p>A. While in Diagnostics, press the CLEAN key within the first 120 seconds of power up to cycle the latch motor to the locked position. "1" should display in the first clock digit from the left when locked. Press the CLEAN key to cycle the latch motor to the unlocked position. The first clock digit should toggle to "0" when the door is unlocked.</p> <p>If the digit did not toggle, go to step B.</p> <p>If motor runs continuously, wait until motor reaches the unlocked position, open the door and press the OFF key. Go to step B.</p> <p>If motor did not run go to step H.</p> <p>If the digit did not toggle after replacing the door latch motor assembly, go to step D.</p> <p>If the digit did not toggle after replacing the door switch harness, go to step F.</p> <p>If the digit did toggle, door latch switch is operating correctly.</p> <p>B. Unplug oven or disconnect power.</p> <p>C. Replace door latch motor assembly. Go to step K.</p> <p>D. Unplug oven or disconnect power.</p> <p>E. Check integrity of all harness wires and connections between the appliance manager and the door latch switch assembly. Ensure no wires are pinched or damaged.</p> <p>If the wiring harness is damaged replace the door latch switch harness. Go to step K.</p> <p>If wiring is good go to step K.</p> <p>F. Unplug oven or disconnect power.</p> <p>G. Replace appliance manager. Go to step K.</p> <p>H. Unplug oven or disconnect power.</p> <p>I. Check integrity of latch mechanism, ensuring alignment of latch assembly and door slot. Correct any mechanical malfunction.</p> <p>J. Check continuity of the latch motor and electrical connections between the appliance manager P8 and motor.</p> <p>If continuity is present, replace appliance manager. Go to step K.</p> <p>If continuity is not present, go to step K.</p> <p>K. Replace all parts and panels before operating.</p> <p>L. Plug in oven or reconnect power.</p> <p>M. Press OFF, OFF, START to reenter the Diagnostic mode and complete checks. Repeat step A.</p>		

FAILURE (Leftmost 2 Clock Digits)	ERROR (Rightmost 2 Clock Digits)	MESSAGE/DESCRIPTION
		SUGGESTED CORRECTIVE ACTION PROCEDURE
F6	E0	LOST COMMUNICATIONS
<p>PROCEDURE: Before proceeding, press OFF, OFF, START to enter Diagnostic mode and verify the error codes. Ensure AM software, UI software and EEPROM CHECKSUM versions appear on the lower text line. If AM software version does not appear, UI and AM may not be communicating.</p> <p>A. Unplug oven or disconnect power.</p> <p>B. Open the back panels and make sure the P6 connector on the appliance manager and P2 connector on the user interface are fully inserted. If it is not, plug in to the connector and proceed to step F. If it is plugged in, go to step C.</p> <p>C. Visually inspect all the wires between P6 on the appliance manager and P2 on the user interface. Make sure wires are not cut or pinched. If the wires appear to be intact, perform a continuity check between P6-1 of the appliance manager and P2-1 of the user interface board. Complete for P6-2 (AM) to P2-2 (UI), P6-4 (AM) to P2-4 (UI), and P6-5 (AM) to P2-5 (UI). All the measurements made should be less than 5 Ω.</p> <p>If any of these measurements exceed the 5 Ω, go to step E.</p> <p>If the measurements are less than 5 Ω reconnect P2, go to step D.</p> <p>D. Replace the appliance manager. Go to step F.</p> <p>E. Replace the wiring harness (signal). Go to step F.</p> <p>F. Ensure all wiring connections are properly inserted.</p> <p>G. Replace all parts and panels before operating.</p> <p>H. Plug in oven or reconnect power. Observe for longer than 60 seconds to determine if error has been repaired.</p> <p>I. If error does not appear, initiate a bake cycle. Let the cycle run for at least 60 seconds.</p> <p>If no error occurs, cancel the cycle, the problem has been repaired.</p> <p>If error occurs again, restart the troubleshooting procedure at step A. (Except in step D, replace the user interface board if appliance manager has already been replaced.)</p>		

FAILURE (Leftmost 2 Clock Digits)	ERROR (Rightmost 2 Clock Digits)	MESSAGE/DESCRIPTION
		SUGGESTED CORRECTIVE ACTION PROCEDURE
F6	E1 E2	COOK OVEN OVER TEMPERATURE CLEAN OVEN OVER TEMPERATURE
<p>PROCEDURE: Before proceeding, press OFF, OFF, START to enter the Diagnostic mode and verify the error codes.</p> <p>A. If oven is off, turn oven on and inspect all of the elements, convect ring, bake and broil. Visually inspect all elements to ensure they are not operating.</p> <p>B. Unplug oven or disconnect power. Wait 10 seconds.</p> <p>C. Plug in oven or reconnect power.</p> <p>D. Enter into Diagnostics by pressing OFF, OFF, START.</p> <p>E. Press the BAKE key to cycle the bake relay on and off as long as Diagnostic mode is within the first 120 seconds of power up.</p> <p>F. If the bake relay does not cycle, proceed to step G.</p> <p>G. Unplug oven or disconnect power for 30 seconds.</p> <p>H. Plug in oven or reconnect power.</p> <p>I. Enter into Diagnostics by pressing OFF, OFF, START. Press the BAKE key to cycle relay on and off.</p> <p style="padding-left: 20px;">If the bake relay does not cycle on and off, go to step P.</p> <p style="padding-left: 20px;">If the element does not cycle with the relay, go to step N.</p> <p style="padding-left: 20px;">If the element does cycle on and off, go to step J.</p> <p>J. Press the BROIL key, while in Diagnostic mode, to cycle the broil relays. Press BROIL key one time for outer broil element. Ensure outer broil relay energizes by inspecting the outer broil element. Press BROIL key again for inner broil element. Ensure inner broil relay energizes by inspecting the inner broil element.</p> <p style="padding-left: 20px;">If broil relay does not turn on and off, go to step P.</p> <p style="padding-left: 20px;">If the element does not cycle with the relay, go to step N.</p> <p style="padding-left: 20px;">If the element does cycle on and off, go to step K.</p> <p>K. Press the CONVECT key, while in Diagnostic mode, to cycle the convect relay on and off.</p> <p>L. If the convect relay does not turn on and off, go to step P.</p> <p>M. If the element does not cycle with the relay, go to step N.</p> <p>N. Unplug oven or disconnect power.</p> <p>O. Check integrity of all harness wires and connections between the appliance manager and the electrical elements. Ensure all wiring and connections between the appliance manager and elements, and the appliance manager and user interface are intact and properly seated and that no wires are shorted or damaged.</p> <p style="padding-left: 20px;">If the wiring connections are intact, go to step Q.</p> <p style="padding-left: 20px;">If the wiring connections are damaged, go to step S.</p> <p>P. Unplug oven or disconnect power.</p> <p>Q. Replace the appliance manager. Go to step R.</p> <p>R. Replace user interface board. Go to step S.</p> <p>S. Replace the harness.</p> <p>T. Replace all parts and panels before operating.</p> <p>U. Plug in oven or reconnect power.</p> <p>V. Verify operation is normal. Press OFF, OFF, START to reenter the Diagnostic mode and complete checks.</p>		
F6	E3	MINI OVEN/WARM DRAWER OVER TEMPERATURE
<p>PROCEDURE: Oven is not equipped with this feature. If error occurs, before proceeding press OFF, OFF, START to enter into Diagnostic mode and verify the error codes, then replace user interface with correct control associated with this product.</p>		

FAILURE (Leftmost 2 Clock Digits)	ERROR (Rightmost 2 Clock Digits)	MESSAGE/DESCRIPTION
		SUGGESTED CORRECTIVE ACTION PROCEDURE
F6	E4	USER INTERFACE/APPLIANCE MANAGER MISMATCH
<p>PROCEDURE: Before proceeding, press OFF, OFF, START to enter the Diagnostic mode and verify the error codes.</p> <p>A. Unplug oven or disconnect power. Wait for 10 seconds.</p> <p>B. Plug in oven or reconnect power.</p> <p>C. Enter into Diagnostic mode by pressing OFF, OFF, START.</p> <p>D. Press BAKE. Ensure bake relay energizes by inspecting bake element active.</p> <p>E. Press BROIL one time for outer broil element. Ensure outer broil relay energizes by inspecting the outer broil element.</p> <p>F. Press BROIL again for inner broil element. Ensure inner broil relay energizes by inspecting the inner broil element.</p> <p>G. Press SELF CLEAN to drive door latch to lock door. Press again to reset the door latch to normal state.</p> <p>H. Press COOK to activate the low speed cooling fan. Press again for high speed.</p> <p>I. If all functions are working, the PB and UI are properly working.</p> <p>J. Exit Diagnostics by pressing OFF.</p> <p>K. Press BAKE and ensure that bake relay energizes and the control enters the bake preheat. Wait up to 60 seconds to ensure error has been resolved. If error returns, proceed to step L.</p> <p>L. Unplug oven or disconnect power.</p> <p>M. Remove covers for access to oven controls.</p> <p>N. Replace the appliance manager. Ensure all connections are properly seated. Go to step O.</p> <p>O. Replace all parts and panels before operating.</p> <p>P. Plug in oven or reconnect power.</p> <p>Q. Press BAKE and ensure the bake relay energizes and the control enters into bake/preheat. Wait up to 60 seconds to ensure error has been resolved. If error does not return, replace all covers. If error returns, go to step R.</p> <p>R. Replace the user interface. Ensure all connections are properly seated. Go to step S.</p> <p>S. Replace all parts and panels before operating.</p> <p>T. Plug in oven or reconnect power.</p> <p>U. Press BAKE and ensure the bake relay energizes and the control enters into bake/preheat. Wait up to 60 seconds to ensure error has been resolved. If error does not return replace all covers.</p>		
F6	E5	NO CAVITY SIZE COMMAND
<p>PROCEDURE: Control should immediately power up in cavity size select mode. Using key #6 (down) and key #3 (up) scroll through to locate the corresponding cavity size. Once located, press the start key to accept the proper cavity size for the oven being programmed. Control should reinitialize to cavity size selected. If error returns at least 60 seconds after cavity size has been set, go to step A.</p> <p>A. Unplug oven or disconnect power. Wait 10 seconds.</p> <p>B. Plug in oven or reconnect power.</p> <p>C. Enter into Diagnostic mode by pressing OFF, OFF, START. Press #6 (down) once main diagnostics screen appears. Screen should identify cavity size for oven being programmed. If this is incorrectly shown, press CLOCK to edit current programmed size. Press #6 (down) to locate the proper cavity size. Once located, press START to accept the new cavity size. Control will reset and initialize the new cavity size programmed. Wait for 60 seconds to ensure error has been corrected.</p> <p style="padding-left: 20px;">If error is corrected, replace all parts and panels before operating.</p> <p style="padding-left: 20px;">If error returns, proceed to step D.</p> <p>D. Unplug oven or disconnect power.</p> <p>E. Replace user interface oven control ensuring all connections are properly seated and go to step F.</p> <p>F. Replace all parts and panels before operating.</p> <p>G. Plug in oven or reconnect power.</p> <p>H. Control may power up in cavity size select mode. Set cavity size as outlined in step C by locating proper cavity size and pressing START once located.</p> <p>I. Wait for at least 60 seconds to ensure error has been corrected.</p>		

FAHRENHEIT (° F) TO CELSIUS (° C) CONVERSION

The temperature is preset in Fahrenheit, however it can be changed to Celsius.

To Change: Press OPTIONS and then “1” to toggle temperature between Fahrenheit and Celsius settings.

When in Fahrenheit, “°F” follows the oven temperature.

When in Celsius, “°C” follows the oven temperature.

ADJUST OVEN TEMPERATURE CALIBRATION

1. Press OPTIONS and then “6” to set the calibration.
2. On double oven only, press UPPER OVEN or LOWER OVEN to select oven.
Each oven calibration can be independently set.
3. Press “3” to increase and “6” to decrease the temperature.
4. Press START to end calibration.

PROGRAMMING THE CAVITY SIZE

- A. Unplug oven or disconnect power.
- B. Wait 10 (ten) seconds, plug in oven or reconnect power.
- C. Enter Diagnostics mode by pressing OFF, OFF, START.
- D. Press key #6 to show cavity size select screen.
- E. To edit press CLOCK key.
- F. Scroll through cavity sizes by pressing key #6 until size required is displayed.
- G. Once correct size is displayed, press the START key to accept modification.

KEYPADS

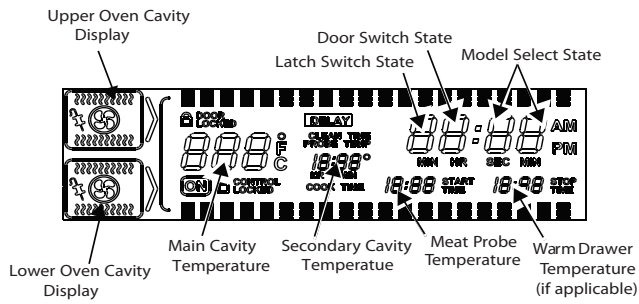

Model Select State	Description
01	Thermal Convection Upper/Thermal Convection Lower
05	Thermal Convection Upper/Standard Clean Lower
07	Standard Clean Upper/Standard Clean Lower

RELAY LOGIC - UPPER AND LOWER OVEN

MODES	RELAYS							
	BAKE	IN BROIL	OUT BROIL	CONV ELEM	CONV FAN	DLB RELAY	OVEN LT	BLOWER
OFF	O	O	O	O	O	⊗	⊗	
BAKE PRE-B	X	+	X	O	O	X	⊗	L
BAKE PRE-A	X	+	+	O	O	X	⊗	L
BAKE SS	+	+	+	O	O	X	⊗	L
CBAKE PRE-B	X	+	+	O	X	X	⊗	L
CBAKE PRE-A	+	O	+	X	X	X	⊗	L
CBAKE SS	+	O	+	X	X	X	⊗	L
FBROIL PRE-B	O	X	X	O	O	X	⊗	L
FBROIL PRE-A	O	X	X	O	O	X	⊗	L
FBROIL SS	O	+	+	O	O	X	⊗	L
INBROIL PRE-B	O	X	O	O	O	X	⊗	L
INBROIL PRE-A	O	X	O	O	O	X	⊗	L
INBROIL SS	O	+	O	O	O	X	⊗	L
CBROIL PRE-B	O	X	X	O	X	X	⊗	L
CBROIL PRE-A	O	X	X	O	X	X	⊗	L
CBROIL SS	+	+	+	O	X	X	⊗	L
CROAST PRE-B	X	+	+	O	X	X	⊗	L
CROAST PRE-A	X	+	+	O	X	X	⊗	L
CROAST SS	O	+	+	O	X	X	⊗	L
BPROOF PRE-B	+	O	O	O	O	X	⊗	L
BPROOF PRE-A	+	O	O	O	O	X	⊗	L
BPROOF SS	+	O	O	O	O	X	⊗	L
DEHYDRATE PRE-B	+	+	+	O	X	X	⊗	L
DEHYDRATE PRE-A	O	O	O	+	X	X	⊗	L
DEHYDRATE SS	O	O	O	+	X	X	⊗	L
CLEAN	+	+	+	O	O	X	O	H

RELAY LOGIC KEY

- O - OFF
- X - ON
- +
- ⊗ - ON OR OFF
- L - ON (LOW SPEED)
- H - ON (HIGH SPEED)

THE FOLLOWING COMPONENTS CAN BE TESTED AT THE CONTROL PANEL:

LOWER OVEN			
COMPONENTS	FRONT/REAR/ TOP SERVICEABLE	CHECK POINTS	RESULTS
Door Switch	Front	P1-2 (BR) to P1-3 (OR)	Door Open = Open Circuit Door Closed = Closed Circuit
Latch Motor	Front	P9-3 (Y) to Neutral (W)	4800 Ω
Oven Temperature Sensor	Rear	P2-3 (GY) to P2-4 (GY)	1091 Ω @ 75°F (23.9°C)
Blower	Rear	P9-2 (GY) to Neutral (W)	181 Ω to 240 Ω 8Ω to 12Ω
Oven Shutdown Thermal Cutoff (non-resettable)	Rear	Bake (R) and In Broil (OR) to Red/White Wire at Double Line Break Relay	Closed Circuit
Bake Element	Rear	T5-3 (R) to In Broil (OR) T5-3 (R) to Double Line Break Relay (R/W)	26 Ω to 30 Ω
Inner Broil Element	Front	T5-4 (OR) to Bake (R) T5-4 (OR) to Double Line Break Relay (R/W)	31 Ω to 36 Ω
Outer Broil Element	Front	T5-1 (BU) to Red/White Wire at Double Line Break Relay	53 Ω to 59 Ω
Convection Ring Element	Front	T5-2 (Y) to Red/White Wire at Double Line Break Relay	33 Ω to 37 Ω
Convection Fan Motor	Rear	P9-1 (OR/W) to Neutral (W)	8 Ω to 12 Ω
Latch Switch	Front	P1-1 (T) to P1-2 (BR)	Door Unlocked = Open Circuit Door Locked = Closed Circuit
Meat Probe Jack	Rear	P2-7 (Y) to P2-8 (G)	Probe into jack - check for 78 kΩ at room temperature

NOTES :

- The oven shutdown thermal cutoff (non-resettable) is located at the top of the oven.
- It will shut down all elements if the temperature at the top of the oven exceeds component limits.
- The upper and lower oven Blower Speed Resistor are connected in parallel.

UPPER OVEN			
COMPONENTS	FRONT/REAR/ TOP SERVICEABLE	CHECK POINTS	RESULTS
Door Switch	Front	P1-5 (BR) to P1-7 (OR)	Door Open = Open Circuit Door Closed = Closed Circuit
Latch Motor	Front	P8-5 (Y) to Neutral (W)	4800 Ω
Oven Temperature Sensor	Rear	P2-1 (V) to P2-2 (V)	1091 Ω @ 75°F (23.9°C)
Blower	Rear	P9-2 (GY) to Neutral (W)	181 Ω to 240 Ω
Light Power Supply	Top	Primary Winding Secondary Winding	40 Ω to 45 Ω Less than 1 Ω
Oven Shutdown Thermal Cutoff (non-resettable)	Rear	Bake (R) and In Broil (OR) to Red/White Wire at Double Line Break Relay	Closed Circuit
Bake Element	Rear	T3-3 (R) to In Broil (OR) T3-3 (R) to Double Line Break Relay (R/W)	26 Ω to 30 Ω
Inner Broil Element	Front	T3-4 (OR) to Bake (R) T3-4 (OR) to Double Line Break Relay (R/W)	31 Ω to 36 Ω
Outer Broil Element	Front	T3-1 (BU) to Red/White Wire at Double Line Break Relay	53 Ω to 59 Ω
Convection Ring Element	Front	T3-2 (Y) to Red/White Wire at Double Line Break Relay	33 Ω to 37 Ω
Convection Fan Motor	Rear	P8-3 (OR) to Neutral (W)	8 Ω to 12 Ω
Latch Switch	Front	P1-4 (T) to P1-5 (BR)	Door Unlocked = Open Circuit Door Locked = Closed Circuit
Meat Probe Jack	Rear	P2-5 (OR) to P2-6 (W)	Probe into jack - check for 78 kΩ at room temperature
Control Power Transformer (XFMR)	Top	Primary Winding Secondary Winding (Connected on User Interface Board) P1-1 to P1-3 P1-4 to P1-5 P1-7 to P1-8	22.9 Ω +/-10% 0.71 Ω +/-10% 0.742 Ω +/-10% 2.37 Ω +/-10%
Blower Speed Resistors	Top	P8-4 (GY) to P9-2(GY)	86 Ω +/-5%

WIRING DIAGRAM & STRIP CIRCUITS

WIRING DIAGRAM

SYMBOLS

GROUND (CHASSIS)	RELAY COIL	ENCLOSED THERMISTOR
PLUG WITH FEMALE CONNECTOR	RELAY CONTACTS	OPERATED BY DOOR
RECEPTACLE WITH MALE CONNECTOR	HEATING ELEMENT	THERMAL CUTOFF (NON-RESETTABLE)
LIGHT	SOLENOID	RESISTOR
AC DRIVE MOTOR		

NOTES:

- When replacing the electronic control, be sure to program the cavity size. See "Programming the Cavity Size" on page 1.
- Dots indicate connections or splices.
- Circuit shown in STANDBY/OFF mode with oven door closed.
- Pin locations in parenthesis represent the lower cavity.

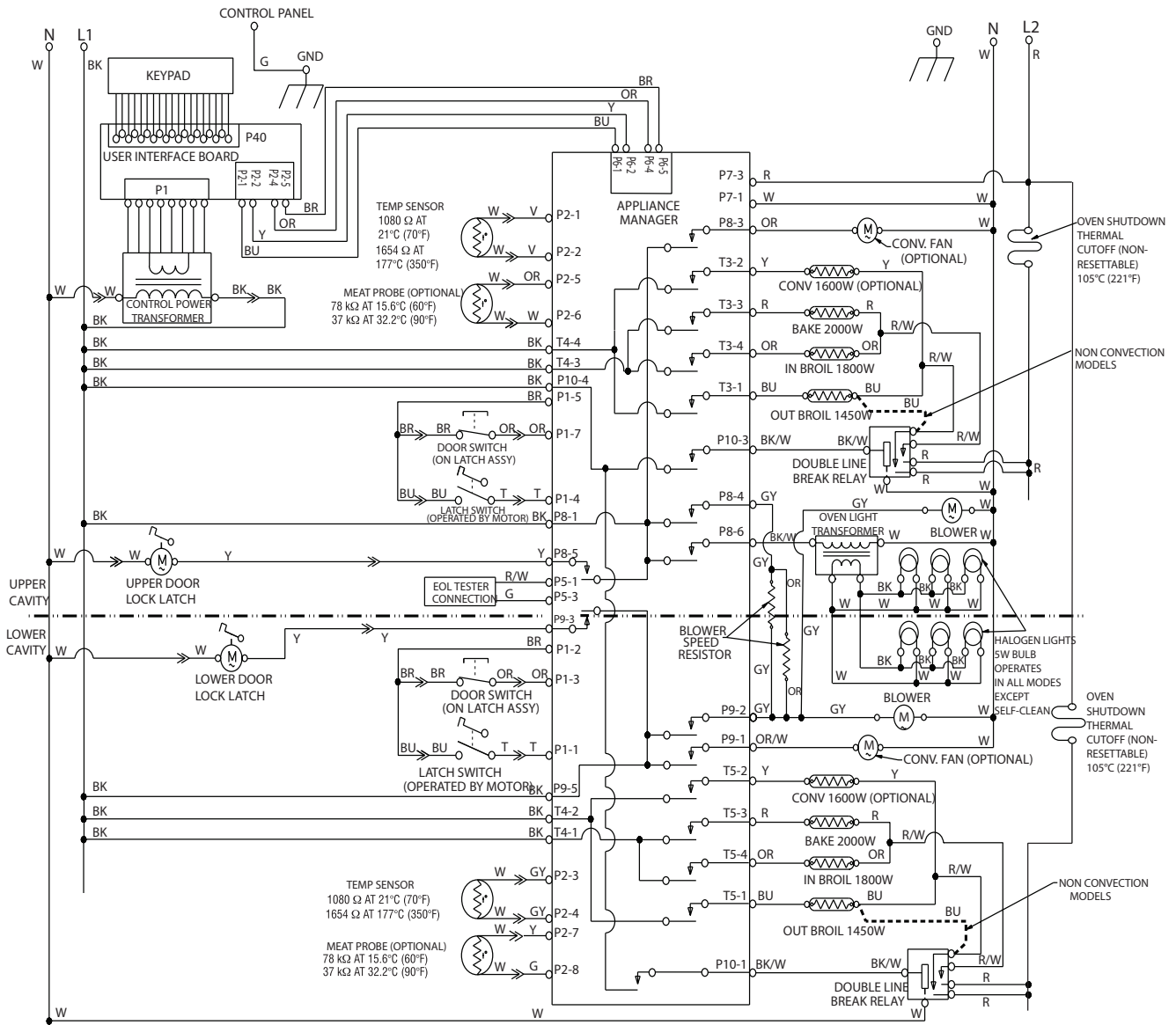

STRIP CIRCUITS

The following individual circuits are for use in diagnosis, and are shown in the ON position. Do not continue with the diagnosis of the appliance if a fuse is blown, a circuit breaker is tripped, or if there is less than a 240 volt power supply at the wall outlet.

BAKE PREHEAT B - BAKE PREHEAT A - BAKE SS

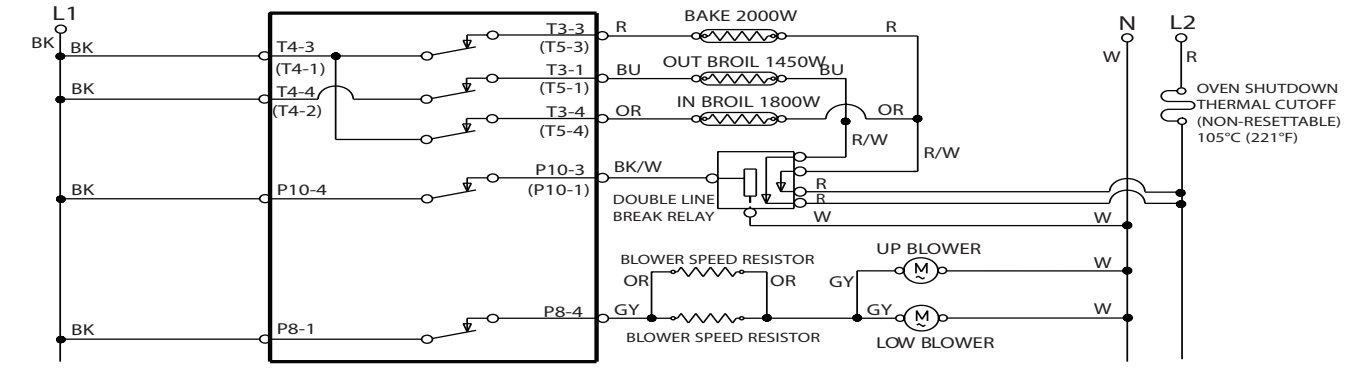

INNER BROIL PREHEAT B - INNER BROIL PREHEAT A - INNER BROIL SS

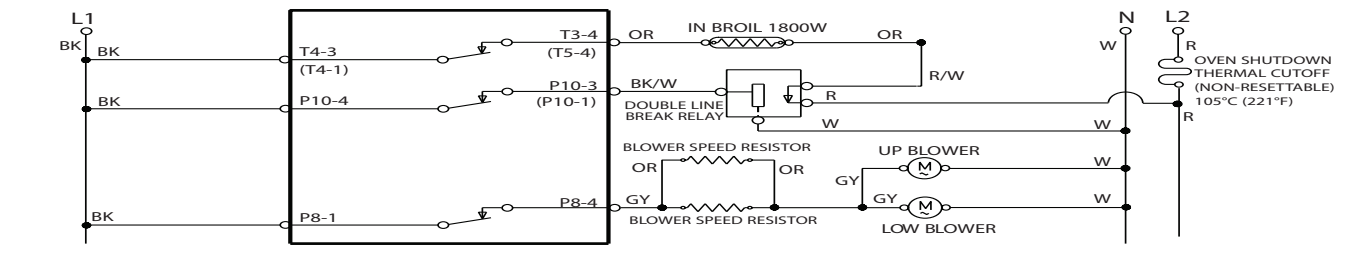

FULL BROIL PREHEAT B - FULL BROIL PREHEAT A - FULL BROIL SS

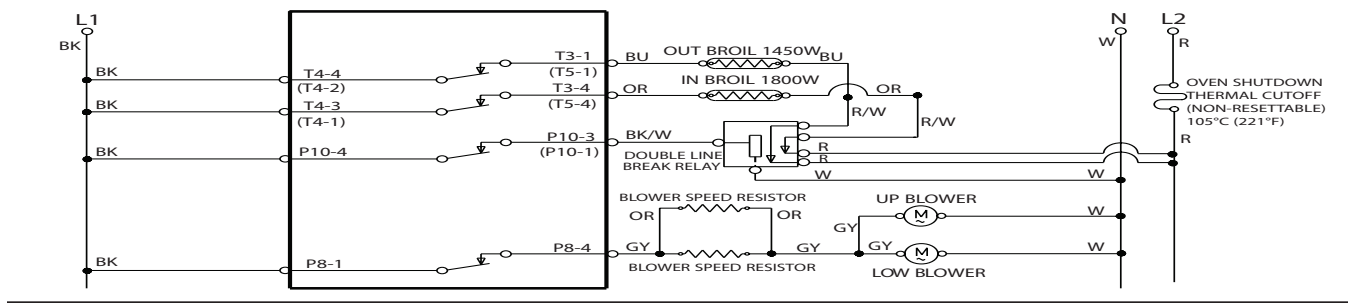

CONVECT BROIL PREHEAT B - CONVECT BROIL PREHEAT A - CONVECT BROIL SS (CONVECTION MODELS ONLY)

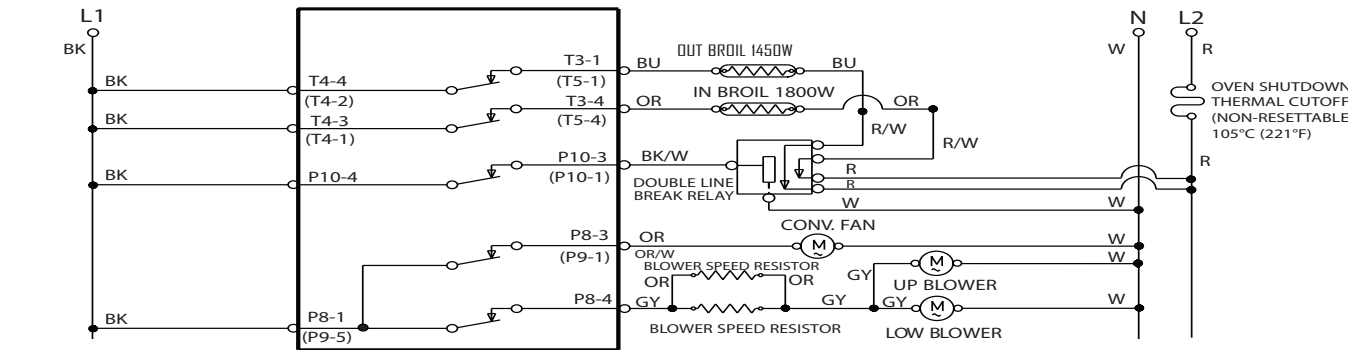

BREAD PROOF PREHEAT B - BREAD PROOF PREHEAT A - BREAD PROOF SS

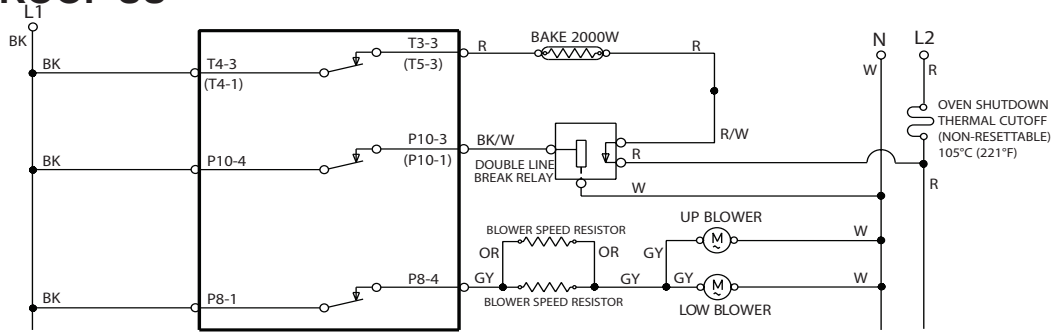

CONVECT BAKE PREHEAT A - CONVECT BAKE SS

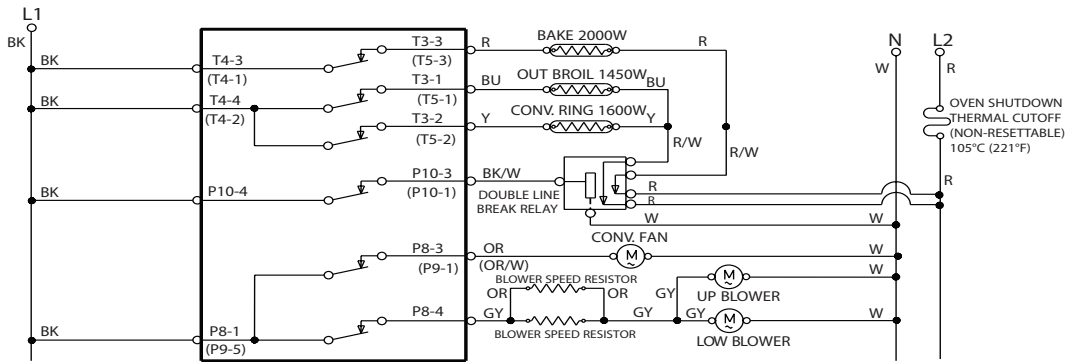

CONVECT BAKE PREHEAT B - CONVECT ROAST PREHEAT B - CONVECT ROAST PREHEAT A - CONVECT ROAST SS - DEHYDRATE PREHEAT B (CONVECTION MODELS ONLY)

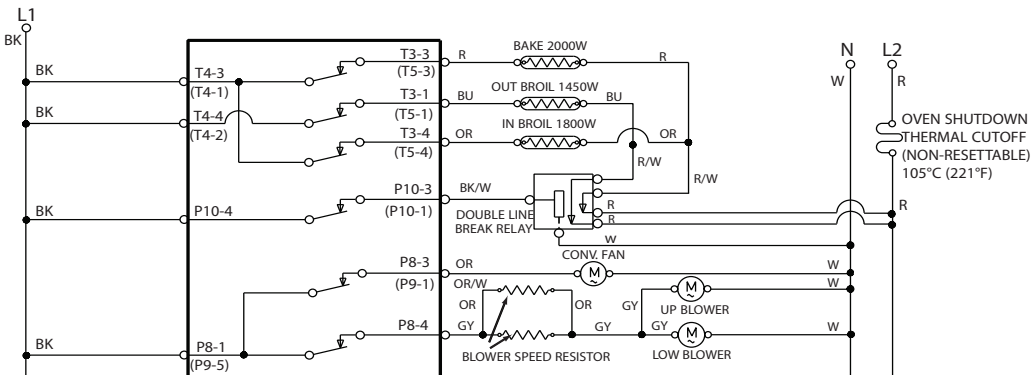

DEHYDRATE PREHEAT SS - DEHYDRATE PREHEAT A (CONVECTION MODELS ONLY)

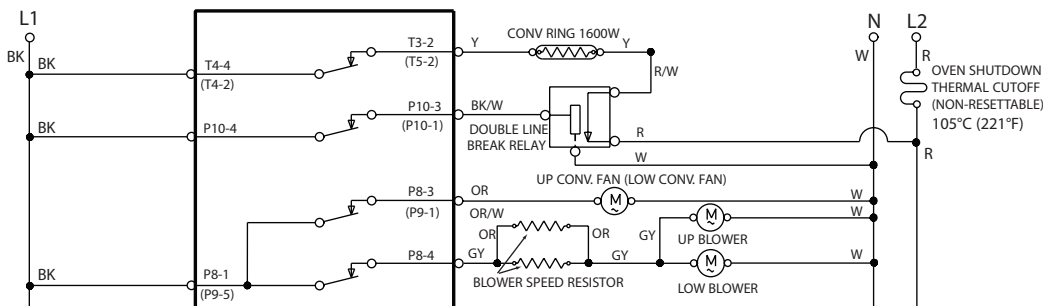

CLEAN

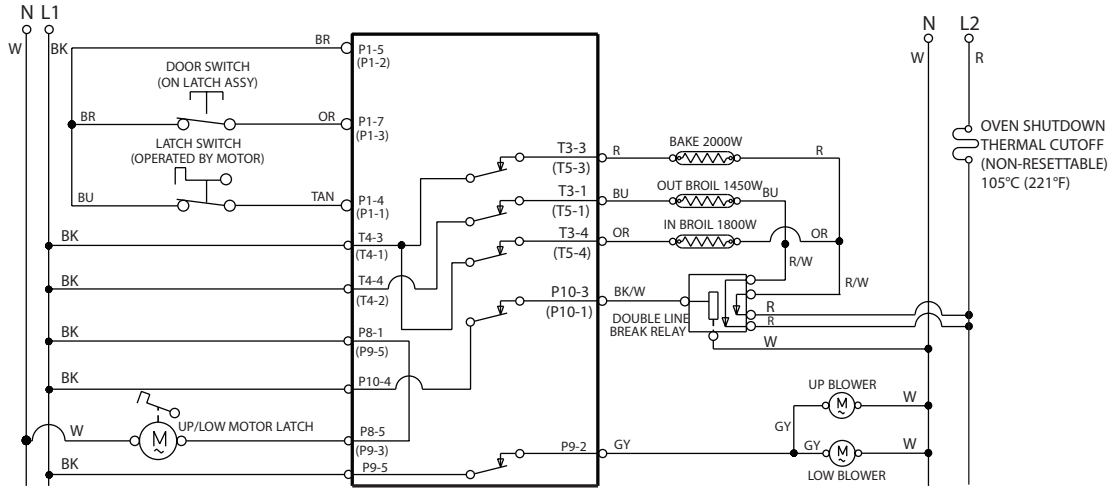

PRODUCT SPECIFICATIONS AND WARRANTY INFORMATION SOURCES

IN THE UNITED STATES:

FOR PRODUCT SPECIFICATIONS AND WARRANTY INFORMATION CALL:

FOR WHIRLPOOL PRODUCTS: 1-800-253-1301
FOR KITCHENAID PRODUCTS: 1-800-422-1230
FOR ROPER PRODUCTS: 1-800-447-6737

FOR TECHNICAL ASSISTANCE WHILE AT THE CUSTOMER'S HOME CALL:

THE TECHNICAL ASSISTANCE LINE: 1-800-832-7174

**HAVE YOUR STORE NUMBER READY TO IDENTIFY YOU AS AN
AUTHORIZED IN-HOME SERVICE PROFESSIONAL**

FOR LITERATURE ORDERS:

PHONE: 1-800-851-4605

FOR TECHNICAL INFORMATION AND SERVICE POINTERS:

www.servicematters.com

IN CANADA:

FOR PRODUCT SPECIFICATIONS AND WARRANTY INFORMATION CALL:

1-800-461-5681

FOR TECHNICAL ASSISTANCE WHILE AT THE CUSTOMER'S HOME CALL:

THE TECHNICAL ASSISTANCE LINE: 1-800-488-4791

**HAVE YOUR STORE NUMBER READY TO IDENTIFY YOU AS AN
AUTHORIZED IN-HOME SERVICE PROFESSIONAL**

KitchenAid®
FOR THE WAY IT'S MADE.®