



CONSUMER SERVICES TECHNICAL  
EDUCATION GROUP PRESENTS

KR-37

## 30" & 36" FLUSH-MOUNT GAS COOKTOPS



Model GLS3064R S

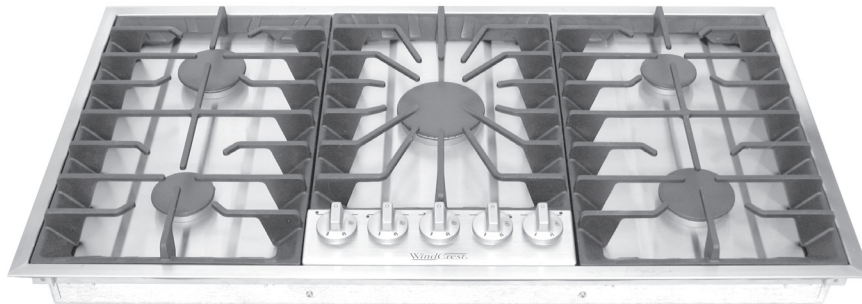

Model GLS3665R S

JOB AID  
Part No. 8178526



## **FORWARD**

This Whirlpool Job Aid, “30” & 36” Flush-Mount Gas Cooktops” (Part No. 8178526), provides the technician with information on the installation and service of the 30” & 36” Flush-Mount Gas Cooktops. For specific information on the model being serviced, refer to the “Use and Care Guide” provided with the 30” & 36” Flush-Mount Gas Cooktops.

The Wiring Diagrams used in this Job Aid are typical and should be used for training purposes only. Always use the Wiring Diagram supplied with the product when servicing the unit.

## **GOALS AND OBJECTIVES**

The goal of this Job Aid is to provide information that will enable the service technician to properly diagnose malfunctions and repair the 30” & 36” Flush-Mount Gas Cooktops.

The objectives of this Job Aid are to:

- Understand and follow proper safety precautions.
- Successfully troubleshoot and diagnose malfunctions.
- Successfully perform necessary repairs.
- Successfully return the cooktop to its proper operational status.

WHIRLPOOL CORPORATION assumes no responsibility for any repairs made on our products by anyone other than Authorized Service Technicians.

# TABLE OF CONTENTS

	Page
<b>GENERAL</b> .....	1-1
Safety First .....	1-1
Whirlpool Model & Serial Number Designations .....	1-2
Model & Serial Number Label Location .....	1-3
Specifications .....	1-4
Whirlpool Gas Cooktop Warranty .....	1-5
<b>INSTALLATION INFORMATION</b> .....	2-1
L.P Gas Conversion .....	2-1
<b>COMPONENT ACCESS</b> .....	3-1
Component Locations .....	3-1
Removing The Burners And Cooktop .....	3-2
Removing A Burner Base .....	3-4
Removing An Ignition Switch And Gas Valve .....	3-5
Removing An Ignitor And A Spark Module .....	3-6
Removing The Power Supply Cord .....	3-8
<b>COMPONENT TESTING</b> .....	4-1
Ignition Switch .....	4-1
<b>WIRING DIAGRAMS</b> .....	5-1

— NOTES —

# GENERAL SAFETY FIRST

## **Your safety and the safety of others is very important.**

We have provided many important safety messages in this Job Aid and on the appliance. Always read and obey all safety messages.



This is the safety alert symbol.

This symbol alerts you to hazards that can kill or hurt you and others.

All safety messages will follow the safety alert symbol and either the word “DANGER” or “WARNING.” These words mean:

**! DANGER**

**You can be killed or seriously injured if you don't immediately follow instructions.**

**! WARNING**

**You can be killed or seriously injured if you don't follow instructions.**

All safety messages will tell you what the potential hazard is, tell you how to reduce the chance of injury, and tell you what can happen if the instructions are not followed.

# WHIRLPOOL MODEL & SERIAL NUMBER DESIGNATIONS

## MODEL NUMBER

<b>MODEL NUMBER</b>	<b>G</b>	<b>L</b>	<b>S</b>	<b>30</b>	<b>64</b>	<b>R</b>	<b>S</b>	<b>0</b>
<b>PRODUCT GROUP</b> R = ELECTRIC COOKING PRODUCTS S = GAS COOKING PRODUCTS G = WHIRLPOOL GOLD								
<b>PRODUCT IDENTIFICATION</b> C = BUILT-IN COOKTOP J = GOLD ELECTRIC COOKTOP L = GOLD GAS COOKTOP								
<b>CONFIGURATION</b> S = PORCELAIN / STEEL TOP T = TEMPERED GLASS TOP (GAS ONLY) C = CERAMIC GLASS TOP M = MODULAR DOWNDRAFT								
<b>MODEL SIZE</b> 20 = 20" 30 = 30" 36 = 36"								
<b>FEATURE VARIATIONS</b> 0 = LOW SPEED COIL ELECTRIC / OPEN LOW END BURNER GAS / OPEN BAYS 1 = HIGH SPEED COIL ELECTRIC / SEALED BURNERS 2 = CERAMIC RADIANT ELECTRIC 3 = CERAMIC RADIANT / DUAL 4 = MODULAR 6 = FLUSH MOUNT  0 = NO ELEMENTS / BURNERS 2 = TWO ELEMENT / BURNER 4 = FOUR ELEMENT / BURNER 5 = FIVE ELEMENT / BURNER								
<b>YEAR OF INTRODUCTION</b> R = 2005								
<b>COLOR CODE</b> S = STAINLESS STEEL								
<b>ENGINEERING CHANGE (0, 1, 2, ETC.)</b>								

## SERIAL NUMBER

<b>SERIAL NUMBER</b>	<b>XD</b>	<b>S</b>	<b>32</b>	<b>02111</b>
<b>DIVISION RESPONSIBILITY</b> XD = OXFORD / CNP INDUSTRIES				
<b>YEAR OF PRODUCTION</b> S = 2005				
<b>WEEK OF PRODUCTION</b> 32ND WEEK				
<b>PRODUCT SEQUENCE NUMBER</b>				

# MODEL & SERIAL NUMBER LABEL LOCATION

The Model/Serial Number label location is shown below.

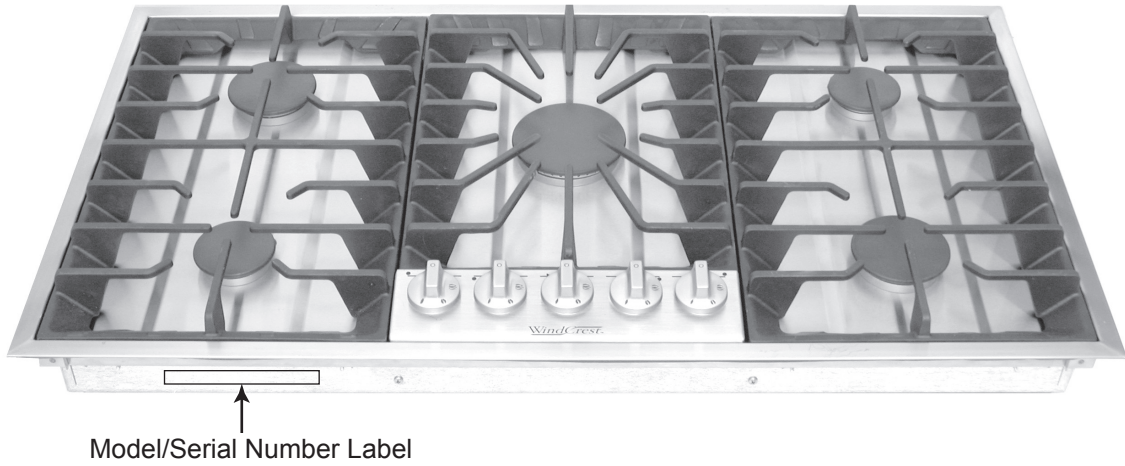

# SPECIFICATIONS

<b>Model Number</b>	<b>GLS3064R S</b>	<b>GLS3665R S</b>
Model Description	Steel cooktop	Steel cooktop
Size-Configuration	30"	36"
<b>Dimensions/Specifications</b>		
Overall Width (in)	30"	36"
Overall Depth (in)	20 1/8"	20 1/8"
Cutout Width (in)	29 3/8"	35 3/8"
Cutout Depth (in)	19 1/2"	19 1/2"
<b>Ratings</b>		
Electric	120 Volts/60Hz	120 Volts/60Hz
Circuit Amps	15 AMP	15 AMP
<b>Exterior</b>		
Cooktop Burners	Stainless	Stainless
Control Type Knob	Metal	Metal
Simmer Switch	No	No
Hot Surface Indicator	No	No
<b>Cooktop Burners</b>		
Burner Configuration	2 front, 2 rear	2 front, 3 rear
Gas Burner Type	Sealed	Sealed
Gas R Front Output (BTU)(Nat/LP)	9,000	9,000
Gas L Front Output (BTU)(Nat/LP)	15,000	12,000
Gas R Rear Output (BTU)(Nat/LP)	12,000	12,000
Gas L Rear Output (BTU)(Nat/LP)	9,000	9,000
Gas Center Rear Output (BTU)(Nat/LP)	N/A	15,000
Gas Ignition	Electronic	Electronic
Gas Auto Reignition	Yes	Yes
Gas Valves Degrees	210	210
LP Conversion	Kit Included	Kit Included
<b>Miscellaneous</b>		
Installation Instructions	9761893	9761893
Use & Care Guide	9761890	9761890
Wiring Diagram	In installation instructions	In installation instructions
Agency Approvals	UL, CUL	UL, CUL
Approved to Install Over BI Oven	No	No
Hardware Included	Yes	Yes
Residential Use Only	Yes	Yes
Warranty	Yes	Yes
Full	12 months	12 months
Extended	5 Yr. limited (burners)	5 Yr. limited (burners)



# WHIRLPOOL GAS COOKTOP WARRANTY

## FULL ONE-YEAR WARRANTY

For one year from the date of purchase, when this appliance is operated and maintained according to instructions attached to or furnished with the product, Whirlpool Corporation will pay for FSP® replacement parts and repair labor to correct defects in materials or workmanship. Service must be provided by a Whirlpool designated service company.

---

## FIVE-YEAR LIMITED WARRANTY

On cooktop burners, in the second through fifth years from the date of purchase, when this appliance is operated and maintained according to instructions attached to or furnished with the product, Whirlpool Corporation will pay for FSP® replacement parts for any gas burner to correct defects in materials or workmanship. Service must be provided by a Whirlpool designated service company.

---

### Whirlpool Corporation will not pay for:

1. Service calls to correct the installation of your appliance, to instruct you how to use your appliance, to replace house fuses or correct house wiring, or to replace owner-accessible light bulbs.
  2. Repairs when your appliance is used in other than normal, single-family household use.
  3. Pickup and delivery. Your appliance is designed to be repaired in the home.
  4. Damage resulting from accident, alteration, misuse, abuse, fire, flood, improper installation, acts of God or use of products not approved by Whirlpool Corporation or Whirlpool Canada Inc.
  5. Repairs to parts or systems resulting from unauthorized modifications made to the appliance.
  6. Replacement parts or repair labor costs for units operated outside the United States or Canada.
  7. In Canada, travel or transportation expenses for customers who reside in remote areas.
  8. Any labor costs during limited warranty.
- 

### **WHIRLPOOL CORPORATION AND WHIRLPOOL CANADA SHALL NOT BE LIABLE FOR INCIDENTAL OR CONSEQUENTIAL DAMAGES.**

Some states or provinces do not allow the exclusion or limitation of incidental or consequential damages, so this exclusion or limitation may not apply to you. This warranty gives you specific legal rights and you may also have other rights which may vary from state to state or province to province.

**Outside the 50 United States and Canada, this warranty does not apply. Contact your authorized Whirlpool dealer to determine if another warranty applies.**

If you need service, first see the “Troubleshooting” section of the Use and Care Guide. After checking “Troubleshooting,” additional help can be found by checking the “Assistance or Service” section or by calling the Whirlpool Customer Interaction Center, **1-800-253-1301** (toll-free), from anywhere in the U.S.A. For parts and service in Canada, please call **1-800-807-6777**. For product related questions in Canada, please call **1-800-461-5681**.

— NOTES —

# INSTALLATION INFORMATION

## L.P. GAS CONVERSION

### **⚠️ WARNING**



**Electrical Shock Hazard**  
**Disconnect power before servicing.**  
**Replace all parts and panels before operating.**  
**Failure to do so can result in death or electrical shock.**

**NOTE: Gas conversion from natural to L.P. gas must be done by a qualified installer.**

To convert the cooktop for use with L.P. gas, perform the following steps.

1. Unplug cooktop or disconnect power.
2. Turn off gas supply to cooktop.
3. Use a screwdriver and remove the access cap on the gas distribution valve.

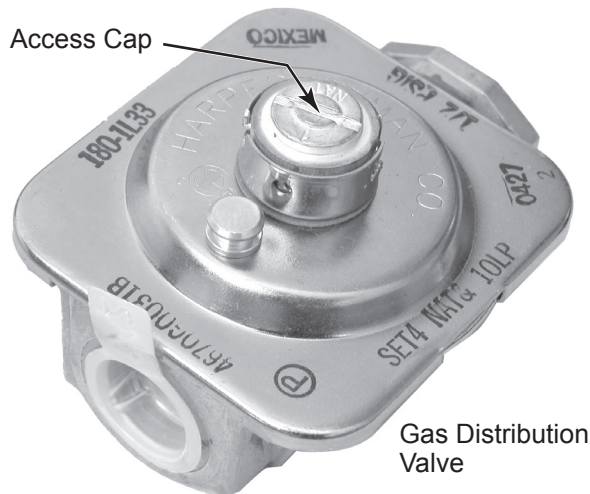

4. Turn the access cap over so that the letters L.P. are facing up, and then reinstall the cap on the valve.

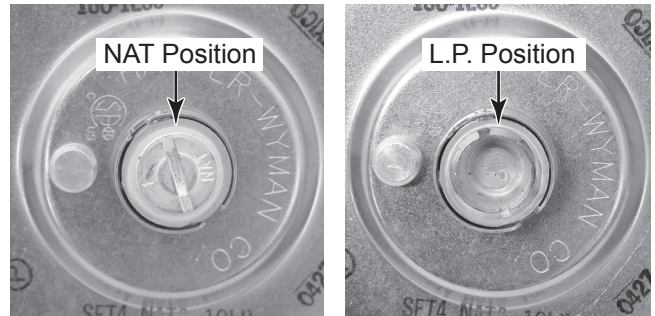

5. To convert the cooktop burners for use with L.P. gas:

- a) Remove the grates and burner caps.

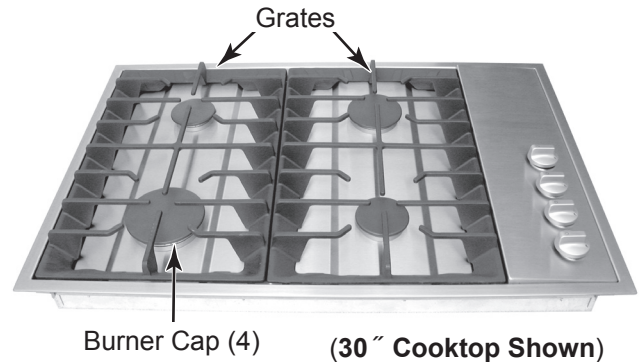

- b) Remove the two screws from the burners and remove the burners from the cooktop.

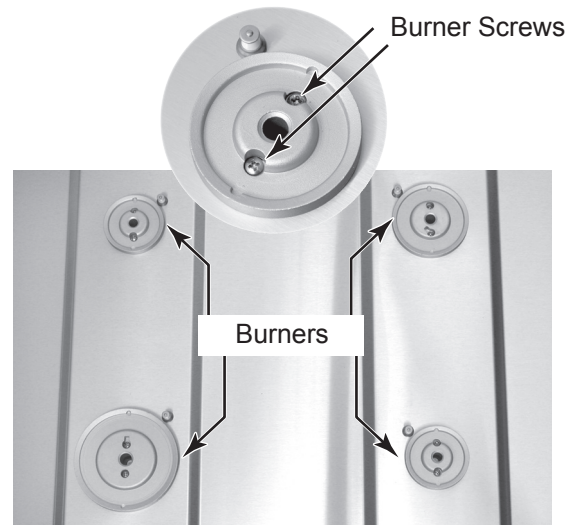

c) Open the L.P. Conversion pack and remove the contents.

**NOTE:** Each burner, and its associated gas valve, has a plastic bag containing an L.P. gas orifice and a bypass jet pin. The bags are marked with the burner/valve B.T.U. rating. Match the B.T.U. rating on the bag with the burner and valve locations (shown in the drawings at the bottom right column) for the cooktop you are converting. **Do not open the bags until you are ready to use them.**



**Orifice Bags (36" Model)**



**IMPORTANT:** Once removed, place the natural gas orifice **on top** of the appropriate orifice bag. After the L.P. orifice from the bag is installed, place the natural gas orifice in the bag for reuse if the cooktop is ever converted back to natural gas. Also do this for the bypass jet pins in step 6. Be careful not to interchange the natural and L.P. gas orifices and pins.

d) Use a 7 mm socket wrench and remove the orifices from the burner bases.

**NOTE:** Place a small piece of masking tape along the inside edge of the socket to help hold each orifice in the driver.

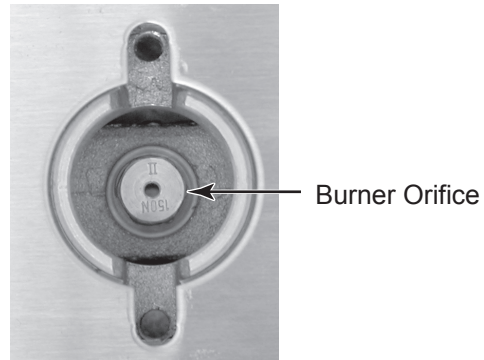

e) Install the L.P. orifices in their appropriate burner bases (be careful not to crossthread or overtighten the orifices).

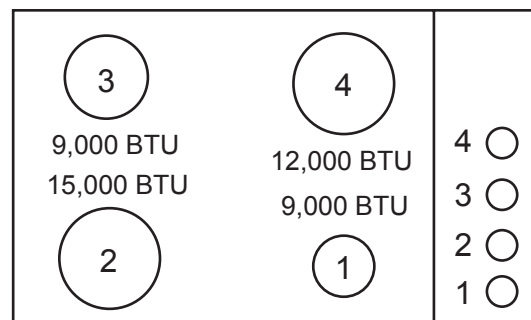

**30" Model Cooktop**

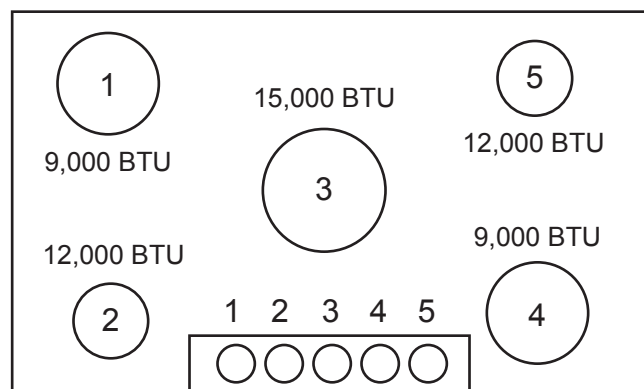

**36" Model Cooktop**

f) Reinstall the burners on the cooktop.  
g) Replace the burner caps on the burners.

6. **To convert the gas valves for use with L.P. gas:**

- a) Remove the control knobs from the gas valves.
- b) Reach inside the control panel openings with your fingers, and slide the rubber guards off the gas valve stems.
- c) Using a small screwdriver, unscrew and remove the bypass jet pins from the gas valves.
- d) Install the L.P. bypass jet pins in the gas valves until they are just snug. Do not overtighten the pins.

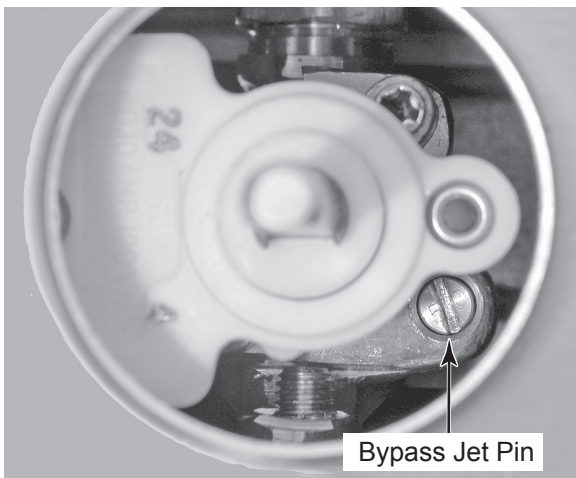

- e) Reinstall the control knobs on the gas valves.
- f) Remove the backing from the L.P. conversion sticker, and press the sticker onto the bottom of the cooktop chassis near the model/serial number label.

7. **To check the burner operation:**

- a) Turn on the power and gas supply to the cooktop.
- b) Light a burner, and quickly turn the gas valve from low to high, and then back to low. Both the high and low flames should be on steady and not go out. If the flame should go out at the high or low setting, it should automatically reignite.
- c) Repeat the previous step for the remaining burners.
- d) Reinstall the cooktop grates.

**— NOTES —**

# COMPONENT ACCESS

This section instructs you on how to service each component inside the 30" & 36" flush-mount gas cooktops. The components and their locations are shown below.

## COMPONENT LOCATIONS

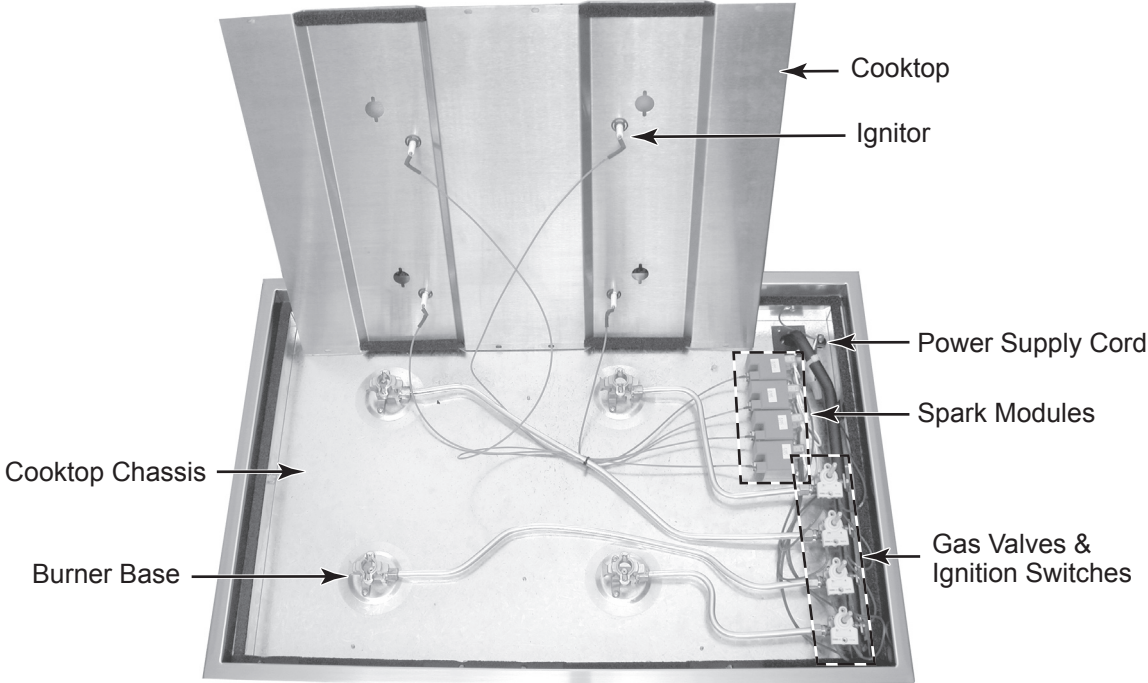

30" Model Cooktop

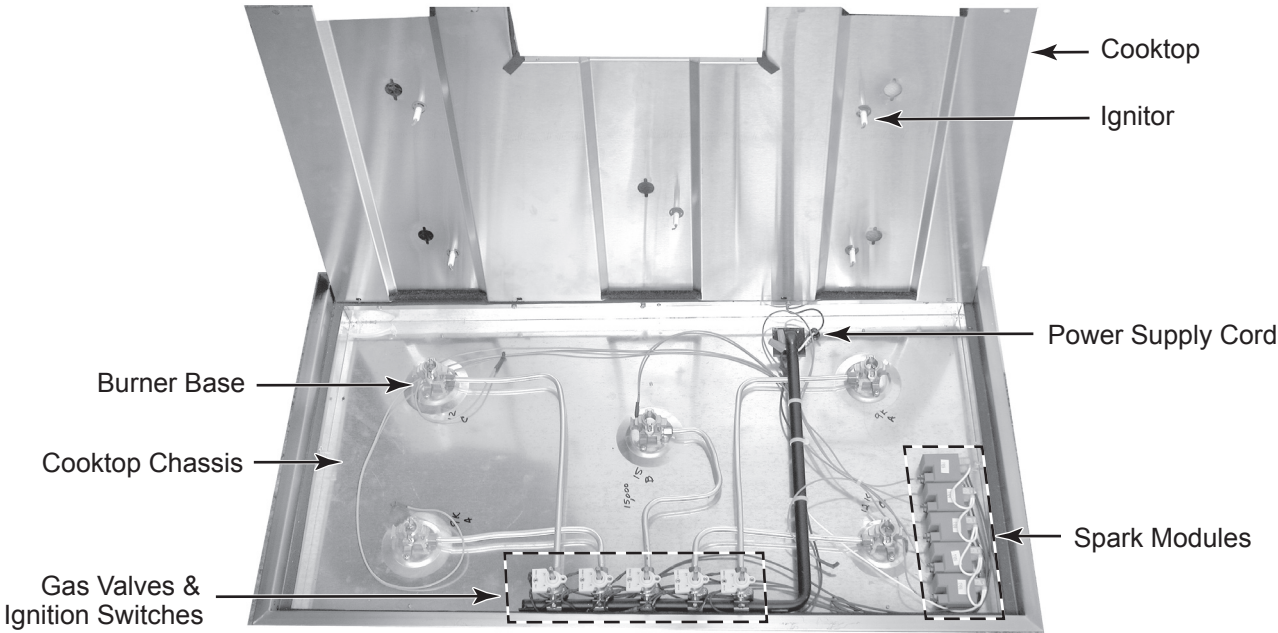

36" Model Cooktop

# REMOVING THE BURNERS AND COOKTOP

## ⚠️ WARNING



### Electrical Shock Hazard

**Disconnect power before servicing.**

**Replace all parts and panels before operating.**

**Failure to do so can result in death or electrical shock.**

1. Unplug cooktop or disconnect power.
2. Turn off gas supply to cooktop.
3. Lift the burner grates off the cooktop.
4. Lift the burner caps off the burners.
5. Pull the control knobs off the gas valve stems.

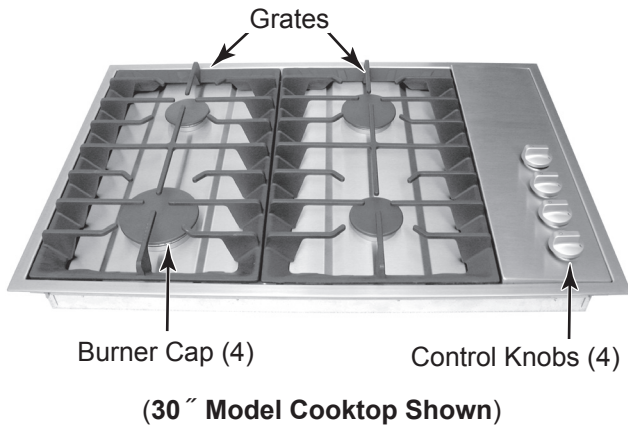

6. Remove the two screws from each of the burners and remove the burners from the cooktop.

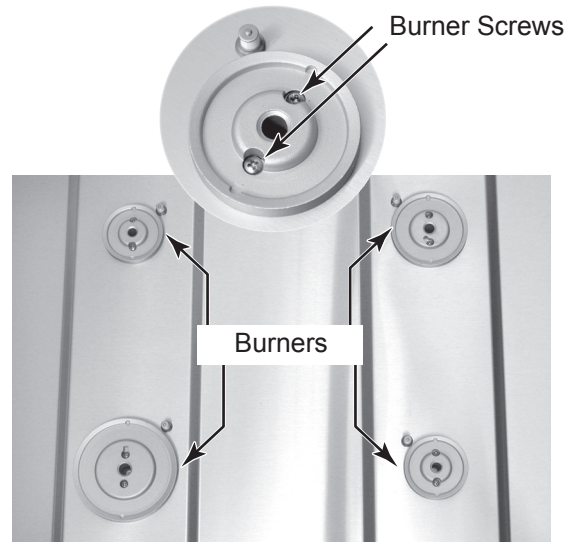

7. Remove the eight screws from the cooktop.
8. Remove the screws from the side of the control panel, and lift the control panel off the cooktop chassis.

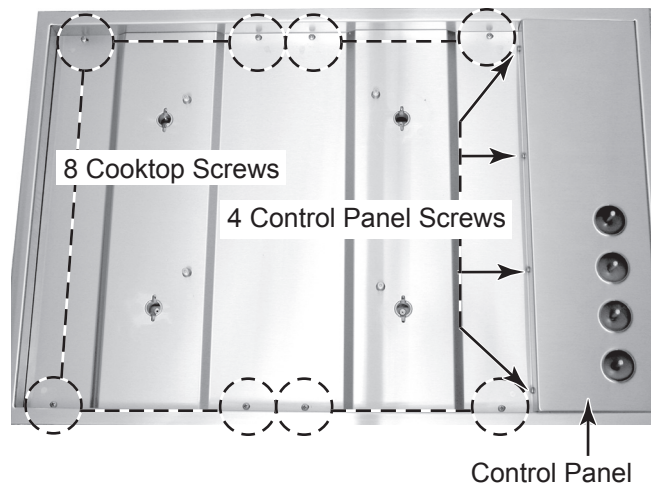



- Lift the cooktop off the cooktop chassis, disconnect the wires from the ignitor terminals, and remove the cooktop.

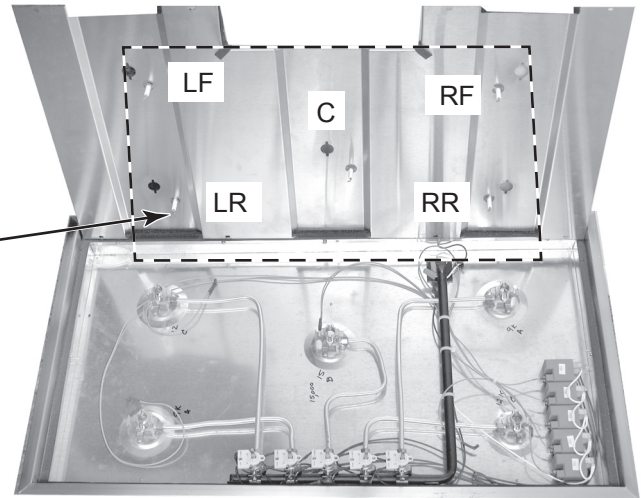
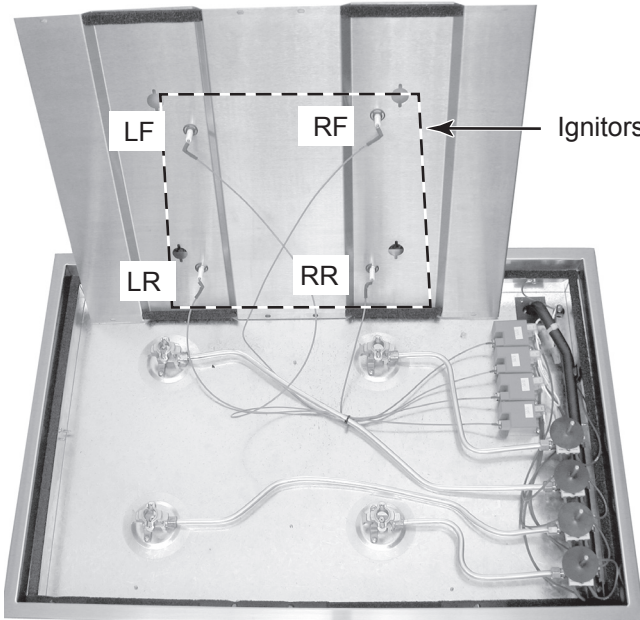

**REASSEMBLY NOTE:** Since each of the burner ignitors for the 30" and 36" cooktops has its own spark module, make sure that you connect each of the module output wires to its corresponding ignitor.

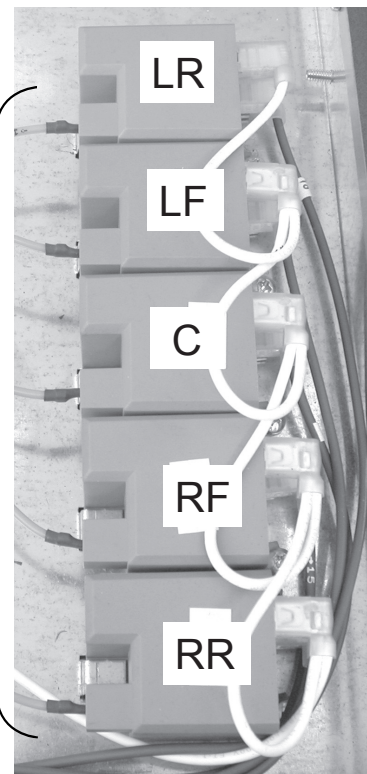

5 Spark Module Output Wires To Ignitors



4 Spark Module Output Wires To Ignitors

Spark Modules

## REMOVING A BURNER BASE

### **! WARNING**



#### **Electrical Shock Hazard**

**Disconnect power before servicing.**

**Replace all parts and panels before operating.**

**Failure to do so can result in death or electrical shock.**

1. Unplug cooktop or disconnect power.
2. Turn off gas supply to cooktop.
3. Remove the cooktop from the unit (see page 3-2 for the procedure).

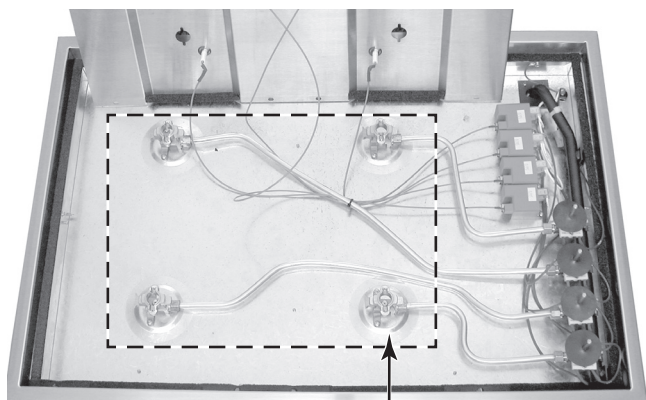

(30" Model Cooktop) Burner Bases

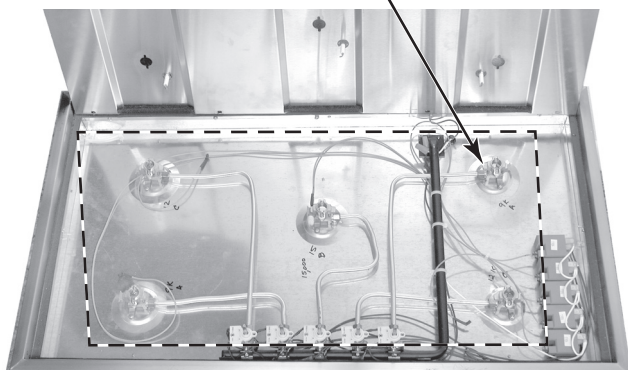

(36" Model Cooktop)

4. Remove the 9/16" gas line nut from the burner base.
5. Remove the two screws from the burner base and remove the base from the cooktop chassis.

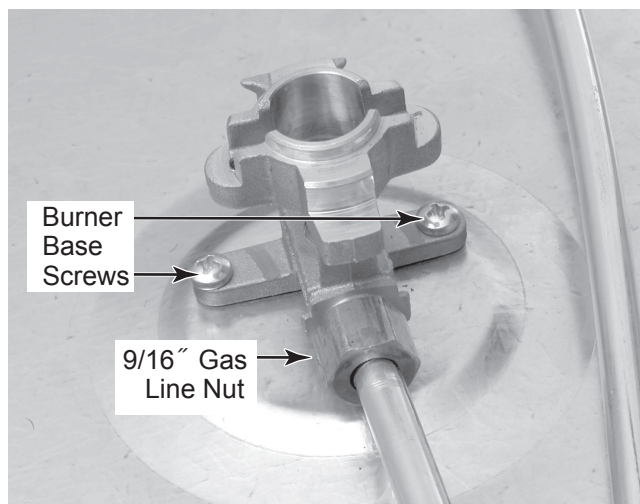

6. Remove the orifice from the burner base using a 7 mm socket, and install the orifice in the new burner base. Do not over-tighten the orifice when you install it.

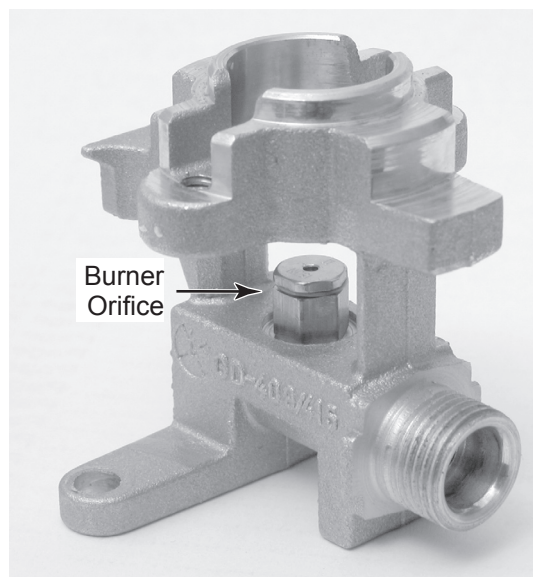

**IMPORTANT:** Refer to the "Reassembly Note" on page 3-3.

# REMOVING AN IGNITION SWITCH AND GAS VALVE

## ⚠️ WARNING



**Electrical Shock Hazard**  
**Disconnect power before servicing.**  
**Replace all parts and panels before operating.**  
**Failure to do so can result in death or electrical shock.**

1. Unplug cooktop or disconnect power.
2. Turn off gas supply to cooktop.
3. Remove the grates and pull the control knobs off the gas valve stems.
4. Remove the screws from the control panel, then lift and remove the control panel from the unit.

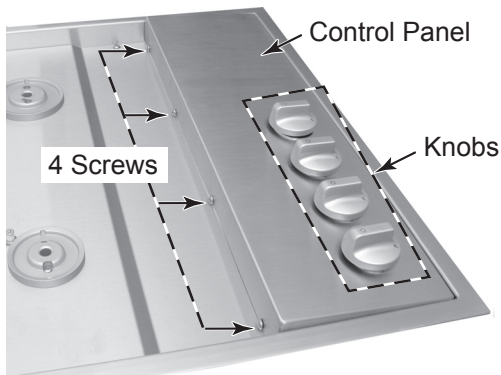

5. Lift the rubber guard off the gas valve you are servicing.

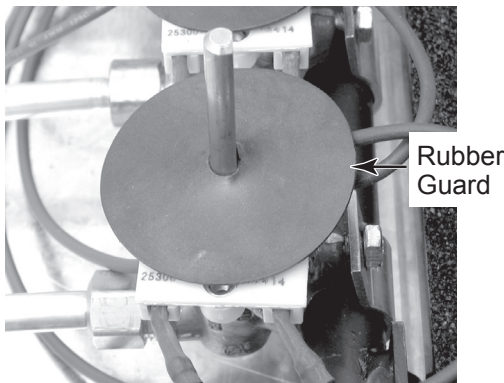

6. **To remove an ignition switch:**
  - a) Disconnect the two wire connectors from the switch terminals.
  - b) Unclip the e-ring from the gas valve shaft.
  - c) Pull the switch straight up and off the gas valve.

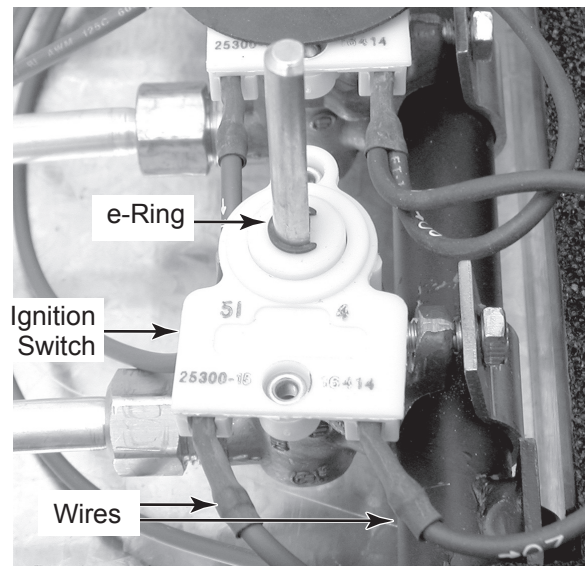

7. **To remove a gas valve:**
  - a) Remove the ignition switch (see step 6).
  - b) Remove the 9/16" gas line nut from the valve.
  - c) Remove the 5/16" hex-head screw from the valve clamp and remove the clamp.
  - d) Remove the gas valve from the manifold.

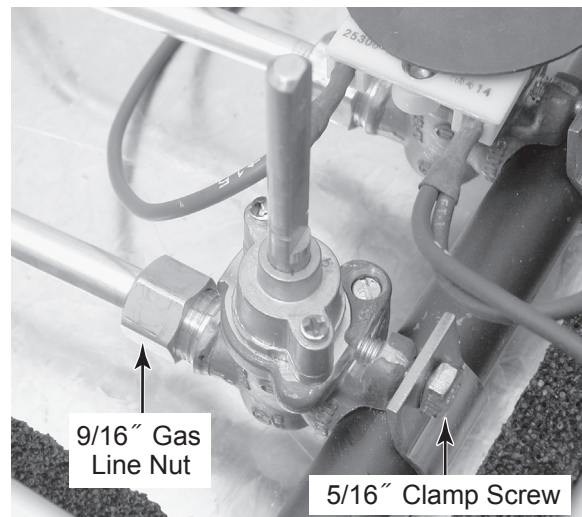

## REMOVING AN IGNITOR AND A SPARK MODULE

### **! WARNING**



#### **Electrical Shock Hazard**

**Disconnect power before servicing.**

**Replace all parts and panels before operating.**

**Failure to do so can result in death or electrical shock.**

1. Unplug cooktop or disconnect power.
2. Turn off gas supply to cooktop.
3. **To remove an ignitor:**
  - a) Remove the cooktop from the unit (see page 3-2 for the procedure).

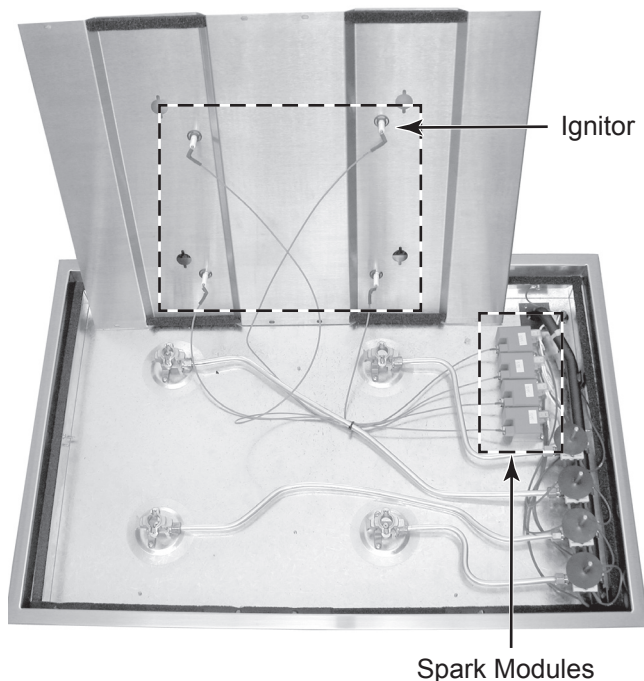

- b) Disconnect the wire from the ignitor terminal (if not already done).
- c) Unclip the e-ring and remove the ignitor from the cooktop.

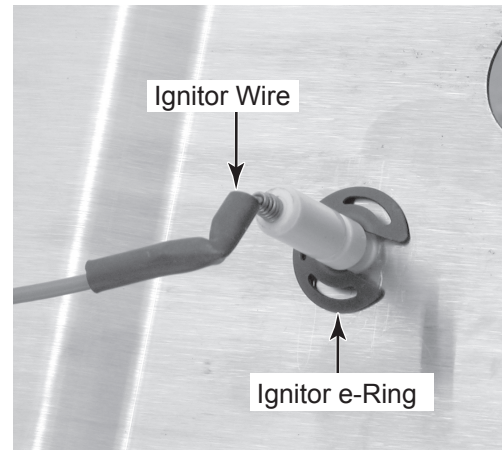

4. **To remove a spark module:**
  - a) Remove the grates and pull the control knobs off the gas valve stems.
  - b) Remove the screws from the control panel, then lift and remove the control panel from the unit.

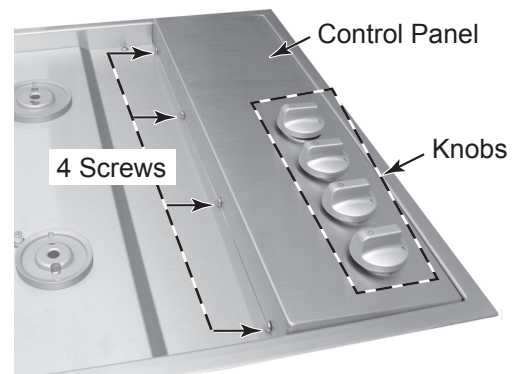

- c) Disconnect the orange, white, and blue wires from the spark module terminals.
- d) Remove the mounting screw.
- e) Unhook the module from the cooktop chassis tab, and remove the module from the cooktop.

**IMPORTANT:** Refer to the “Reassembly Note” on page 3-3.

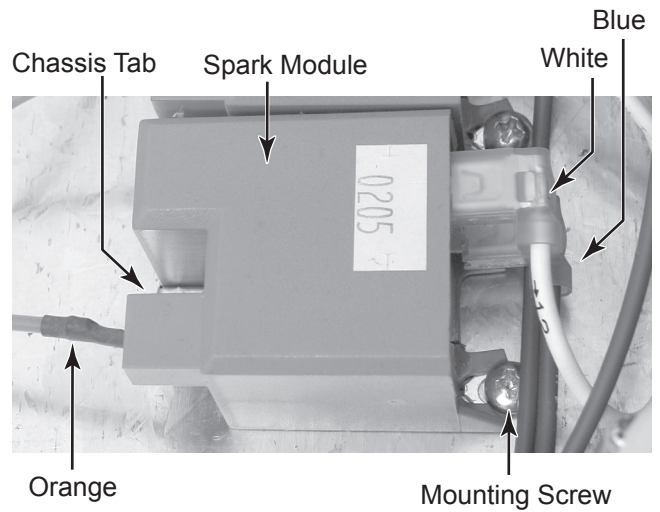

## REMOVING THE POWER SUPPLY CORD

### **! WARNING**



#### **Electrical Shock Hazard**

**Disconnect power before servicing.**

**Replace all parts and panels before operating.**

**Failure to do so can result in death or electrical shock.**

1. Unplug cooktop or disconnect power.
2. Turn off gas supply to cooktop.
3. Remove the grates and pull the control knobs off the gas valve stems.
4. Remove the screws from the control panel, then lift and remove the control panel from the unit.

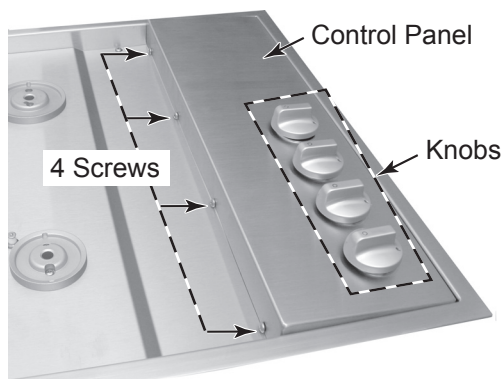

5. If installed, cut the wire tie from around the gas manifold and the power supply cord wires.
6. Remove the twist-on connectors from the black and white power supply cord wires and separate the wires.
7. Remove the chassis screw from the power supply cord green ground wire.
8. Remove the power supply cord strain relief from the chassis hole and remove the cord from the unit.

Ground Wire Screw

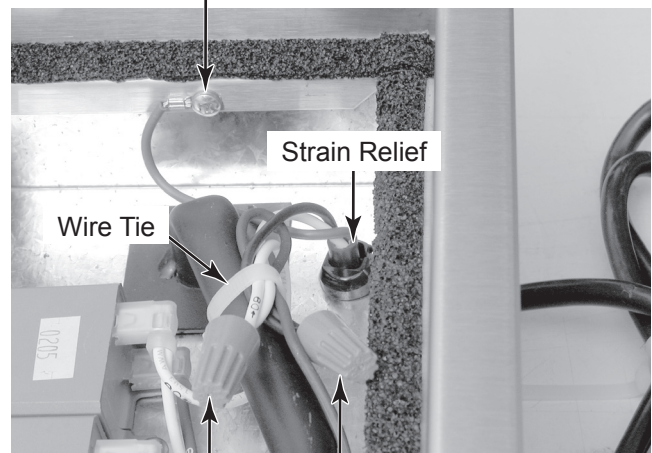

Twist-On Connectors  
(Black & White Wires)

# COMPONENT TESTING

Before testing any of the components, perform the following checks:

- The most common cause for control failure is corrosion on connectors. Therefore, disconnecting and reconnecting wires will be necessary throughout test procedures.
- All tests/checks should be made with a VOM or DVM having a sensitivity of 20,000 ohms-per-volt DC, or greater.
- Check all connections before replacing components, looking for broken or loose wires, failed terminals, or wires not pressed into connectors far enough.
- Resistance checks must be made with power cord unplugged from outlet, and with wiring harness or connectors disconnected.

	<b>⚠ WARNING</b>
	<b>Electrical Shock Hazard</b>
	<b>Disconnect power before servicing. Replace all parts and panels before operating. Failure to do so can result in death or electrical shock.</b>

## IGNITION SWITCH

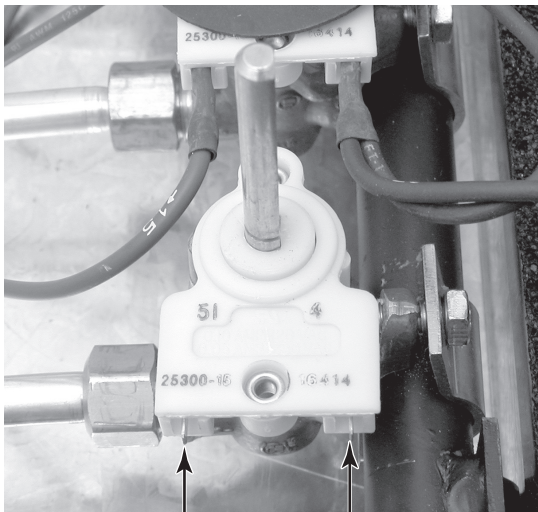

Ignition Switch Terminals

Refer to page 3-5 for the procedure for accessing the ignition switches.

1. Unplug cooktop or disconnect power.
2. Disconnect the two wires from the ignition switch terminals.
3. Set the ohmmeter to the R x 1 scale.
4. Touch the ohmmeter test leads to the ignition switch pins.
5. Turn the gas valve shaft to the Off position. The meter should indicate an open circuit (infinite).
6. Rotate the gas valve shaft. The meter should indicate a closed circuit ( $0 \Omega$ ) at approximately  $20^\circ$  (LITE position) of rotation, and open again at approximately  $30^\circ$  of rotation.

— NOTES —



# WIRING DIAGRAMS

## 30" COOKTOP

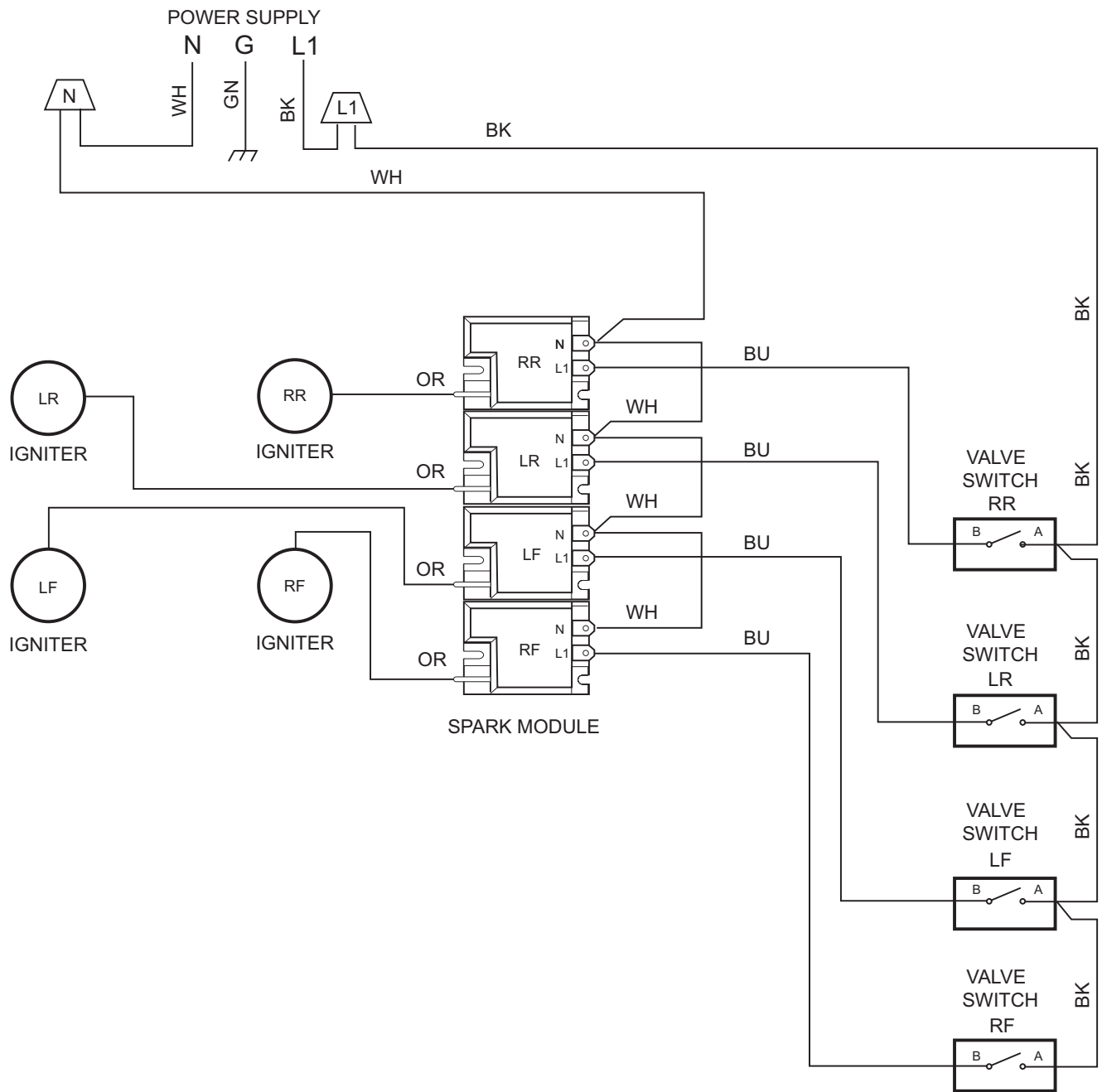

# 36" COOKTOP

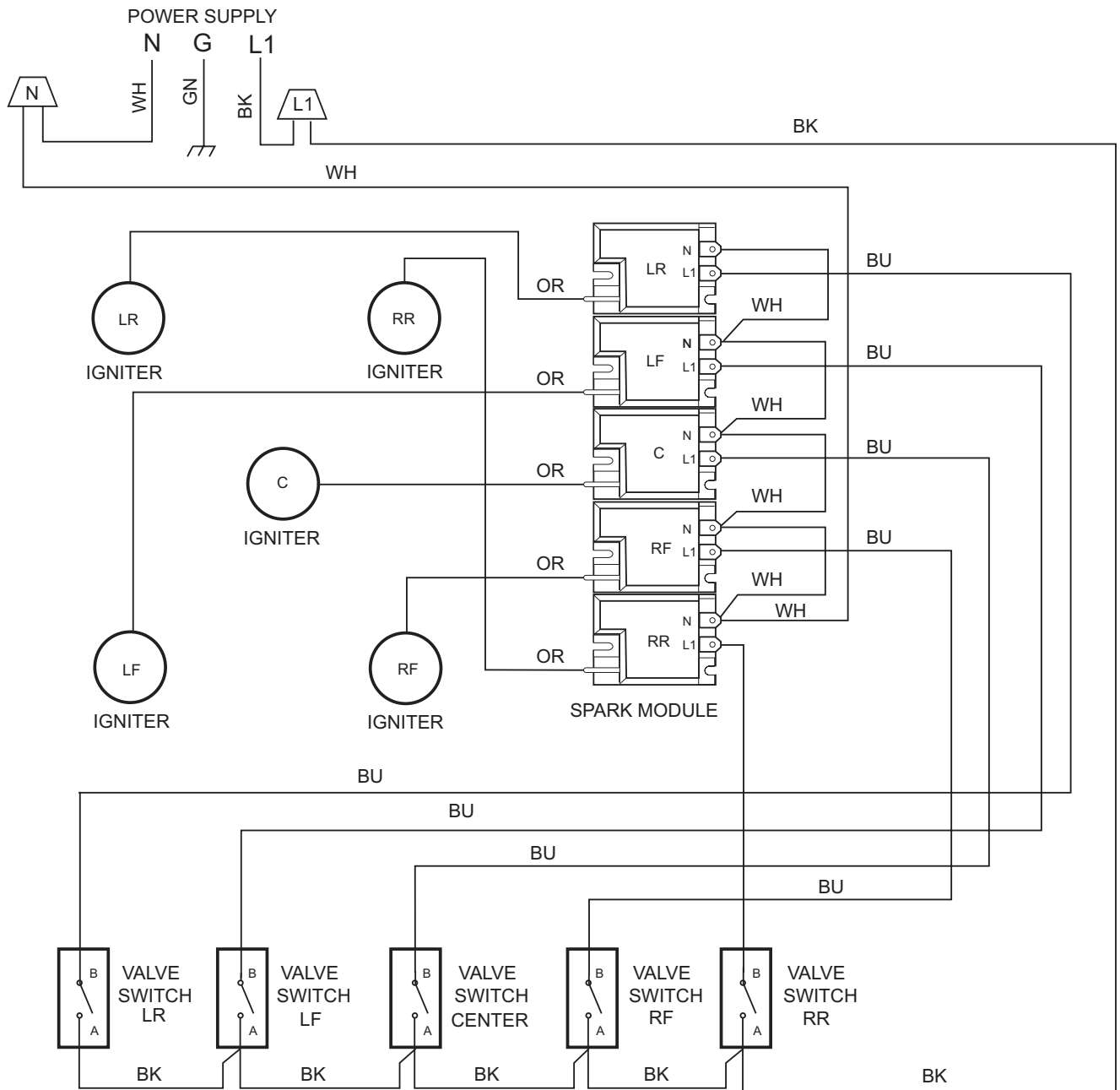

# **PRODUCT SPECIFICATIONS AND WARRANTY INFORMATION SOURCES**

***IN THE UNITED STATES:***

**FOR PRODUCT SPECIFICATIONS AND WARRANTY INFORMATION CALL:**

**FOR WHIRLPOOL PRODUCTS: 1-800-253-1301**

**FOR KITCHENAID PRODUCTS: 1-800-422-1230**

**FOR ROPER PRODUCTS: 1-800-447-6737**

**FOR TECHNICAL ASSISTANCE WHILE AT THE CUSTOMER'S HOME CALL:**

**THE TECHNICAL ASSISTANCE LINE: 1-800-253-2870**

**HAVE YOUR STORE NUMBER READY TO IDENTIFY YOU AS AN  
AUTHORIZED SERVICER**

**FOR LITERATURE ORDERS:**

**PHONE: 1-800-851-4605**

**FOR TECHNICAL INFORMATION AND SERVICE POINTERS:**

**[www.servicematters.com](http://www.servicematters.com)**

---

***IN CANADA:***

**FOR PRODUCT SPECIFICATIONS AND WARRANTY INFORMATION CALL:**

**1-800-461-5681**

**FOR TECHNICAL ASSISTANCE WHILE AT THE CUSTOMER'S HOME CALL:**

**THE TECHNICAL ASSISTANCE LINE: 1-800-488-4791**

**HAVE YOUR STORE NUMBER READY TO IDENTIFY YOU AS AN  
AUTHORIZED SERVICER**

