



TECHNICAL EDUCATION

MICROWAVE DRAWER



Model JMD2124WS

FORWARD

This Jenn-Air, Drawer Microwave Oven job aid (Part No. 8178775), provides the technician with information on the installation, operation, and service of the Drawer Microwave Oven. It is to be used as a training Job Aid and Service Manual. For specific information on the model being serviced, refer to the “Use and Care Guide,” or “Wiring Diagram” provided with the microwave oven.

The Wiring Diagrams used in this Job Aid are typical and should be used for training purposes only. Always use the Wiring Diagram supplied with the product when servicing the unit.

GOALS AND OBJECTIVES

The goal of this Job Aid is to provide detailed information that will enable the service technician to properly diagnose malfunctions and repair the KitchenAid Over-The-Counter Microwave Oven.

The objectives of this Job Aid are to:

- Understand and follow proper safety precautions.
- Successfully troubleshoot and diagnose malfunctions.
- Successfully perform necessary repairs.
- Successfully return the microwave to its proper operational status.

WHIRLPOOL CORPORATION assumes no responsibility for any repairs made on our products by anyone other than Authorized Service Technicians.

TABLE OF CONTENTS

	Page
GENERAL	1-1
Safety First	1-1
Important Information for Service Technicians	1-4
Precautions To Be Observed Before And During Servicing To Avoid Possible Exposure To Excessive Microwave Energy	1-5
R.F. Leakage Test	1-6
Model & Serial Number Label Location.....	1-7
Specifications	1-8
Jenn-Air Cooking Appliance Warranty	1-10
INSTALLATION REQUIREMENTS	2-1
Product Dimensions	2-2
THEORY OF OPERATION	3-1
Microwave Operating Sequence.....	3-1
The Absolute Humidity (AH) Sensor Circuit	3-3
Schematic (Off Condition).....	3-5
COMPONENT ACCESS	4-1
Component Locations	4-1
Accessing Internal Components	4-2
Removing The Power Cord.....	4-4
Removing The Secondary Interlock Switch, Monitor Switch And Front And Rear Door Switch.....	4-5
Removing The Oven Lamp	4-7
Removing The Drawer Assembly.....	4-8
Removing The Stirrer Cover And Stirrer Fan Assemblies	4-9
Removing The Stirrer Motor	4-10
Removing The Humidity Sensor	4-11
Interior Components Locations	4-12
Removing The High Voltage Capacitor And Diode	4-13
Removing The High Voltage Transformer	4-14
Removing The Magnetron.....	4-15
Removing The Cooling Fan Assembly	4-16
Removing The Relay, Noise Filter And Power Supply Boards.....	4-17
Removing The Auto Drawer Gear	4-18
Removing The Rack Gear.....	4-19

	Page
COMPONENT TESTING	5-1
Microwave Oven Power Output Test.....	5-1
Switching Power Supply (Switching Regulator)	5-3
DIAGNOSIS & TROUBLESHOOTING	6-1
Troubleshooting	6-1
Primary Secondary And Monitor Interlock Switch Checkout Procedures.....	6-2
Diagnostics.....	6-3
WIRING DIAGRAM	7-1
Schematic Diagram.....	7-1

GENERAL SAFETY FIRST

Your safety and the safety of others is very important.

We have provided many important safety messages in this Job Aid and on the appliance. Always read and obey all safety messages.



This is the safety alert symbol.

This symbol alerts you to hazards that can kill or hurt you and others.

All safety messages will follow the safety alert symbol and either the word “DANGER” or “WARNING.” These words mean:

⚠ DANGER

You can be killed or seriously injured if you don't immediately follow instructions.

⚠ WARNING

You can be killed or seriously injured if you don't follow instructions.

All safety messages will tell you what the potential hazard is, tell you how to reduce the chance of injury, and tell you what can happen if the instructions are not followed.

ELECTRICAL POWER SUPPLY & GROUNDING REQUIREMENTS

⚠ WARNING



Electrical Shock Hazard

Disconnect power before servicing.

Replace all parts and panels before operating.

Failure to do so can result in death or electrical shock.

⚠ WARNING



Electrical Shock Hazard

Plug into a grounded 3-prong outlet.

Do not remove ground prong.

Do not use an adapter.

Do not use an extension cord.

Failure to follow these instructions can result in death, fire, or electrical shock.

Before touching any oven component or wiring, always unplug the oven from its power source and discharge the high voltage capacitor .

Check that the unit is grounded before troubleshooting. Be careful of the high voltage circuits. Discharge any static charge from your body by touching ground before handling any part of the circuitry on the control board. Electrostatic discharge may damage the control circuit.

Do not touch oven components or wiring during operation. Attach meter leads with alligator clips when making operational tests.

For continued protection against radiation emission, replace only with these types of switches: Primary (Interlock) Switch: SZM-V16-FA-63 or VP-533A-OF; Secondary (Interlock) Switch: SZM-V01-FA-32; Interlock (Monitor) Switch: SZM-VI6-FA-62 or VP-532A-OF; Oven Lamp Switch: SZM-V6-FA-31 or VP-331 A-OD.

It is neither necessary nor advisable to attempt measurement of high voltage.

Attaching the adaptor ground terminal to the wall receptacle cover screw does not ground the appliance unless the cover screw is metal and not insulated and the wall receptacle is grounded through the house wiring.

The microwave oven must be grounded. In the event of an electrical short circuit, grounding reduces the risk of electrical shock by providing an escape wire for the electrical current. The microwave oven is equipped with a cord having a grounding wire with a grounding plug. The plug must be plugged into an outlet that is properly installed and grounded.

Consult a qualified electrician or serviceman if the grounding instructions are not completely understood, or if doubt exists as to whether the microwave oven is properly grounded. Do not use an extension cord. If the power supply cord is too short, have a qualified electrician or serviceman install an outlet near the microwave oven.

ELECTROSTATIC DISCHARGE (ESD) SENSITIVE ELECTRONICS

ESD problems are present everywhere. ESD may damage or weaken the electronic control assembly. The new control assembly may appear to work well after repair is finished, but failure may occur at a later date due to ESD stress.

- Use an antistatic wrist strap. Connect the wrist strap to a green ground connection point or unpainted metal in the appliance; or touch your finger repeatedly to a green ground connection point or unpainted metal in the appliance.
- Before removing the part from its package, touch the antistatic bag to a green ground connection point or unpainted metal in the appliance.
- Avoid touching electronic parts or terminal contacts. Handle the electronic control assembly by the edges only.
- When repackaging the failed electronic control assembly in an antistatic bag, observe the above instructions.

IMPORTANT INFORMATION FOR SERVICE TECHNICIANS

To avoid possible exposure to microwave radiation or energy, visually check the oven for damage to the drawer and drawer seal before operating any oven. Use a microwave survey meter to check the amount of leakage before servicing. In the event the R.F. leakage exceeds 4 mw/cm² at 5 cm, appropriate repair must be made before continuing to service the unit. Check interlock function by operating the drawer latch. The oven cook cycle should cut off before the drawer can be opened.

The drawer and latching assembly contains the radio frequency energy within the oven. The drawer is protected by three safety interlock switches. Do not attempt to defeat them.

Under no circumstances should you try to operate the oven with the drawer open.

- Proper operation of microwave ovens requires that the magnetron be properly assembled to the waveguide and cavity. Never operate the magnetron unless it is properly installed.
- Be sure the "RF" seal is not damaged and is assembled around the magnetron dome properly when installing the magnetron.
- Routine service safety procedures should be exercised at all times.
- Untrained personnel should not attempt service without a thorough review of test procedures and safety information contained in this Job Aid.

Jenn-Air microwave ovens have a monitoring system designed to assure proper operation of the safety interlock systems.

The monitor switch will immediately cause the oven fuse to blow if the drawer is opened and the primary door interlock switch and/or the secondary interlock switch contacts fail in a closed position.

NOTE: Replace a blown fuse with a 20 ampere class H fuse only.

Test the upper and lower door interlock switches, cook relay, and monitor switch (middle switch) for proper operation as described in the component test procedures, before replacing the blown oven fuse.

Do not attempt to repair sticking contacts of any interlock switch, safety switch, or Cook (Latch) relay. The components must be replaced.

Any indication of sticking contacts during component tests requires replacement of that component to assure reliability of the safety interlock system.

If the fuse is blown, the Monitor switch, and the Primary, and Secondary interlock switches must be replaced. Be sure they are properly connected.

PRECAUTIONS TO BE OBSERVED BEFORE AND DURING SERVICING TO AVOID POSSIBLE EXPOSURE TO EXCESSIVE MICROWAVE ENERGY

- A. Do not operate or allow the oven to be operated with the drawer open.
- B. Make the following safety checks on all ovens to be serviced before activating the magnetron or other microwave source, and make repairs as necessary:
 - 1) Interlock Operation
 - 2) Proper Drawer Closing
 - 3) Seal and Sealing Surfaces (Arcing, Wear, and Other Damage)
 - 4) Damage to or Loosening of Hinges and Latches
 - 5) Evidence of Dropping or Abuse
- C. Before turning on the microwave power for any service test or inspection within the microwave generating components, check the magnetron, wave guide or transmission line, and cavity for proper alignment, integrity, and connections.
- D. Any defective or misadjusted components in the interlock, monitor, drawer seal, and microwave generation and transmission systems shall be repaired, replaced, or adjusted, using procedures described in this Job Aid, before the oven is released to the owner.
- E. A microwave leakage check to verify compliance with the Federal Performance Standard should be performed on each oven prior to release to the owner.
- F. Do not attempt to operate the oven if the drawer glass is broken.

R.F. LEAKAGE TEST

EQUIPMENT

- Electromagnetic energy leakage monitor (NARDA 8100B, HOLADAY H 1501).
- 275 ±15 ML glass beaker.

TEST

On every service call, checks for microwave energy emission must be made according to the following manner.

1. Remove the cooking rack from the oven cavity, if the microwave oven is so equipped.
2. Place a 275±15 ML (9.3 oz.) glass of water in the center of the oven bottom.
3. Select "HIGH" cook power, turn the microwave oven on, and test for R.F. leakage at the following locations:
 - a) Around the cabinet at the front.
 - b) Around the door/drawer.
 - c) Across the console panel.
 - d) Horizontally across the door/drawer.
 - e) Vertically across the door/drawer.
 - f) Diagonally across the door/drawer.
 - g) Across the air vents.
 - h) Across the rear air vent.
 - i) All lockseams.
 - j) Weld at bottom.
 - k) Bottom plate.
 - l) Oven feet.
4. The scan speed is one inch per second.

When checking for R.F. leakage, use an approved R.F. measuring device to assure less than 4 mw/cm² emission at 5 cm distance with a maximum scan rate of 2.54 cm/second, in compliance with U.S. Government Department of Health, Education and Welfare 21CFR1030, Performance Standard for Microwave Ovens.

A properly operating drawer and seal assembly will normally register small emissions, but they must be no greater than 4 mw/cm² to allow for measurement uncertainty.

NOTE: Enter leakage readings in space BEFORE and AFTER on the service document.

All microwave ovens exceeding the emission level of 4 mw/cm² must be reported to Dept. of Service for Microwave Ovens immediately and the owner should be told not to use the microwave oven until it has been repaired completely.

If a microwave oven is found to operate with the door open, report to Dept. of Service, the manufacturer and CDRH* immediately. Also tell the owner not to use the oven.

The monitor switch acts as the final safety switch protecting the customer from microwave radiation. If the monitor switch operated to blow the fuse when the interlocks failed, you must replace all interlock switches with new ones, because the contacts of those interlock switches may be melted and welded together.

If safety interlock/monitor switch replacement, or adjustment, is required, you must reconnect the circuit, and perform a continuity check on the monitor circuit.

All repairs must be performed in such a manner that microwave energy emissions are minimal.

Address for CDRH is:

**Office of Compliance (HFZ-312) Center for
Devices and Radiological Health
1390 Piccard Drive
Rockville, MD 20850**

* CDRH: Center for Devices and Radiological

MODEL & SERIAL NUMBER LABEL LOCATION

The Model/Serial Number label location is shown below.

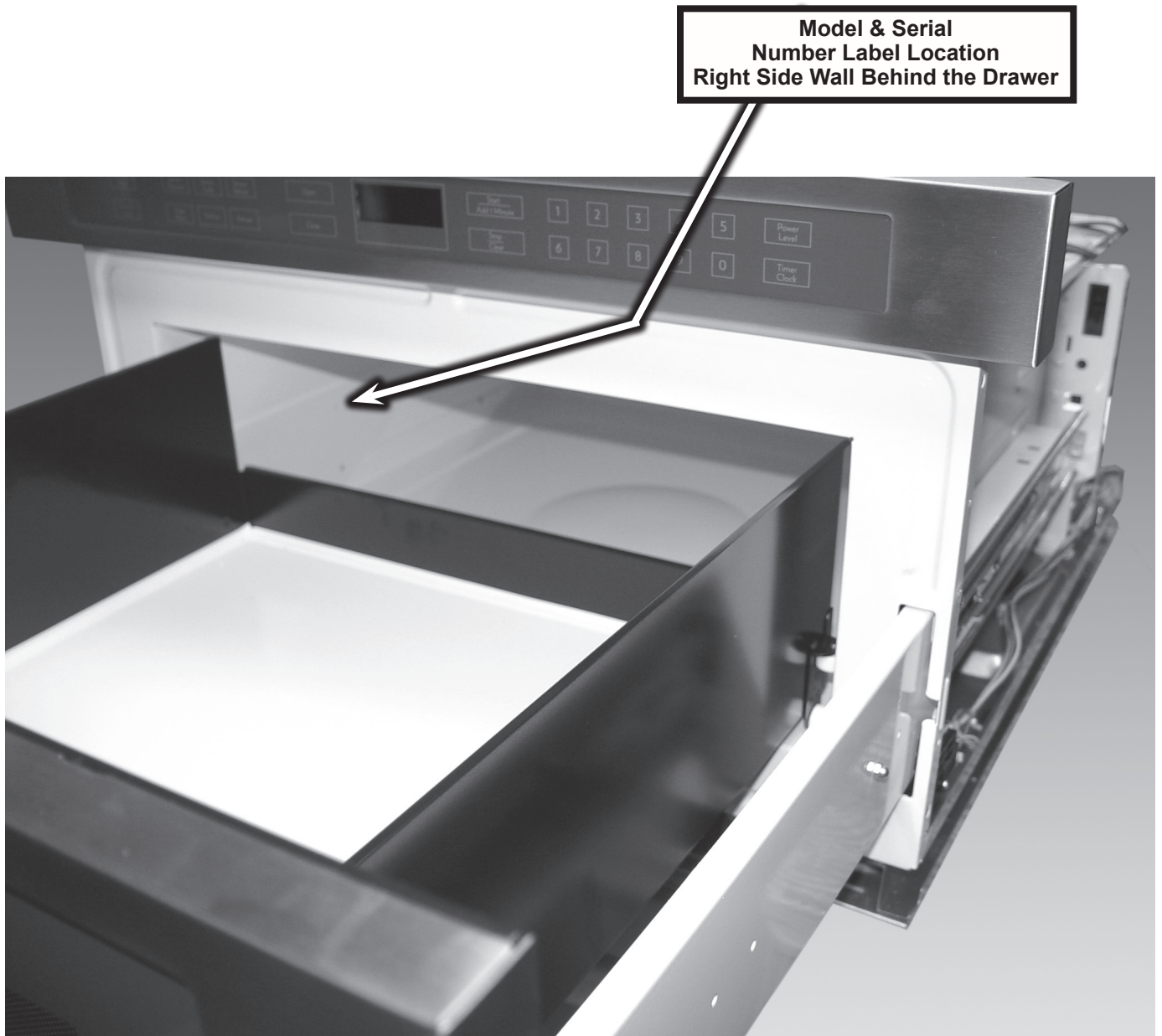

SPECIFICATIONS

MICROWAVE DRAWER SPECIFICATION

ITEM	DESCRIPTION
Power Requirements	Canada - 117 Volts / 13.0 Amperes / 1500 Kw / 60 Hz (CUL) U.S.A. - 120 Volts / 13.6 Amperes / 1500 Kw / 60 Hz (UL) Single phase, 3 wire grounded
Power Output	950 watts (IEC TEST PROCEDURE) Operating frequency of 2450MHz
Cooking Cavity Dimensions 1.0 Cubic Feet	Width 17-11/32 Height 5-7/8" Depth 17-1/8"
Outside Dimensions (Including drawer handle)	Width 23-7/8" Height 15-9/32" Depth 26-1/16"
Control Complement	Touch Control System Clock (1:00 - 12:59) Timer (0 - 99 min. 99 seconds) Microwave Power for Variable Cooking Repetition Rate; P-HI Full power throughout the cooking time P-90..... approx. 90% of Full Power P-80..... approx. 80% of Full Power P-70..... approx. 70% of Full Power P-60..... approx. 60% of Full Power P-50..... approx. 50% of Full Power P-40..... approx. 40% of Full Power P-30 approx. 30% of Full Power P-20..... approx. 20% of Full Power P-10..... approx. 10% of Full Power P-0..... No power throughout the cooking time Setup/Help Pad, Control Lock Pad, Sensor Popcorn Pad, Keep Warm Pad, Sensor Clock Pad, Defrost Pad, Sensor Reheat Pad, Reheat Pad, Open Pad, Close Pad, START/Add 1 Minute Pad, Stop/Clear Pad, Power Level Pad, Timer Clock Pad.
Oven Cavity Light	Yes
Safety Standard	Canadian Standards Association Health Canada, Industry Canada UL Listed FCC Authorized DHHS Rules, CFR, Title 21, Chapter 1, Subchapter J

SPECIFICATIONS

Model	JMD2124WS
Brand	Jenn-Air
Platform	Built-in Microwave Drawer
Size-Configuration	24" 1.0 Cu. Ft.
Feature Level Series	Sensor
Fuel Type	Electric
Color	Stainless
Dimensions	
Overall Height (in)	15 13/32"
Overall Width (in)	23 7/8"
Overall Depth (in)	26 3/16"
Door Swing (in)	Drawer Open 15"
Weight Crated – lb	103
Electrical Specifications	
Voltage	120
Phase	Single
Frequency	60
Circuit Amps @ 120VAC	15
Power Cord	Yes 3 Ft.
UL Approved	Yes
Domestic Use Only	Yes
Residential Use Only	Yes
CUL Approved	Yes
Window Material	Glass
Handle Material	N/A Power Open/Close
Cooking Power Wattage	950
Interior Light	Yes - "On" when open
Light Type	Incandescent
Light Wattage	10
Magnetron	Yes
Levels	10

JENN-AIR® COOKING APPLIANCE WARRANTY

LIMITED WARRANTY

For one year from the date of purchase, when this major appliance is operated and maintained according to instructions attached to or furnished with the product, Jenn-Air brand of Whirlpool Corporation or Whirlpool Canada LP (hereafter "Jenn-Air") will pay for factory specified parts and repair labor to correct defects in materials or workmanship. Service must be provided by a Jenn-Air designated service company. This limited warranty is valid only in the United States or Canada and applies only when the major appliance is used in the country in which it was purchased. Outside the 50 United States and Canada, this limited warranty does not apply. Proof of original purchase date is required to obtain service under this limited warranty.

SECOND THROUGH FIFTH YEAR LIMITED WARRANTY ON CERTAIN COMPONENT PARTS

In the second through fifth years from the date of purchase, when this appliance is operated and maintained according to instructions attached to or furnished with the product, Jenn-Air will pay for factory specified parts for the following components (if applicable to the product) if defective in materials or workmanship:

- Electric element
- Touch Pad and microprocessor
- Glass ceramic cooktop: if due to thermal breakage
- Electronic controls
- Magnetron tube
- Sealed gas burners

ITEMS EXCLUDED FROM WARRANTY

This limited warranty does not cover:

1. Service calls to correct the installation of your major appliance, to instruct you on how to use your major appliance, to replace or repair house fuses, or to correct house wiring or plumbing.
2. Service calls to repair or replace appliance light bulbs, air filters or water filters. Consumable parts are excluded from warranty coverage.
3. Repairs when your major appliance is used for other than normal, single-family household use or when it is used in a manner that is contrary to published user or operator instructions and/or installation instructions.
4. Damage resulting from accident, alteration, misuse, abuse, fire, flood, acts of God, improper installation, installation not in accordance with electrical or plumbing codes, or use of consumables or cleaning products not approved by Jenn-Air.
5. Cosmetic damage, including scratches, dents, chips or other damage to the finish of your major appliance, unless such damage results from defects in materials or workmanship and is reported to Jenn-Air within 30 days from the date of purchase.
6. Any food loss due to refrigerator or freezer product failures.
7. Costs associated with the removal from your home of your major appliance for repairs. This major appliance is designed to be repaired in the home and only in-home service is covered by this warranty.
8. Repairs to parts or systems resulting from unauthorized modifications made to the appliance.
9. Expenses for travel and transportation for product service if your major appliance is located in a remote area where service by an authorized Jenn-Air servicer is not available.
10. The removal and reinstallation of your major appliance if it is installed in an inaccessible location or is not installed in accordance with published installation instructions.
11. Major appliances with original model/serial numbers that have been removed, altered or cannot be easily determined. This warranty is void if the factory applied serial number has been altered or removed from your major appliance.

The cost of repair or replacement under these excluded circumstances shall be borne by the customer.

DISCLAIMER OF IMPLIED WARRANTIES; LIMITATION OF REMEDIES

CUSTOMER'S SOLE AND EXCLUSIVE REMEDY UNDER THIS LIMITED WARRANTY SHALL BE PRODUCT REPAIR AS PROVIDED HEREIN. IMPLIED WARRANTIES, INCLUDING WARRANTIES OF MERCHANTABILITY OR FITNESS FOR A PARTICULAR PURPOSE, ARE LIMITED TO ONE YEAR OR THE SHORTEST PERIOD ALLOWED BY LAW. JENN-AIR SHALL NOT BE LIABLE FOR INCIDENTAL OR CONSEQUENTIAL DAMAGES. SOME STATES AND PROVINCES DO NOT ALLOW THE EXCLUSION OR LIMITATION OF INCIDENTAL OR CONSEQUENTIAL DAMAGES, OR LIMITATIONS ON THE DURATION OF IMPLIED WARRANTIES OF MERCHANTABILITY OR FITNESS, SO THESE EXCLUSIONS OR LIMITATIONS MAY NOT APPLY TO YOU. THIS WARRANTY GIVES YOU SPECIFIC LEGAL RIGHTS, AND YOU MAY ALSO HAVE OTHER RIGHTS WHICH VARY FROM STATE TO STATE OR PROVINCE TO PROVINCE.

If outside the 50 United States and Canada, contact your authorized Jenn-Air dealer to determine if another warranty applies.

If you need service, first see the "Troubleshooting" section of the Use & Care Guide. After checking "Troubleshooting," you may find additional help by checking the "Assistance or Service" section or by calling Jenn-Air. In the U.S.A., call **1-800-688-1100**. In Canada, call **1-800-807-6777**.

9/07

Keep this book and your sales slip together for future reference. You must provide proof of purchase or installation date for in-warranty service.

Write down the following information about your major appliance to better help you obtain assistance or service if you ever need it. You will need to know your complete model number and serial number. You can find this information on the model and serial number label located on the product.

Dealer name _____

Address _____

Phone number _____

Model number _____

Serial number _____

Purchase date _____

INSTALLATION REQUIREMENTS

⚠ WARNING

Excessive Weight Hazard

Use two or more people to move and install the microwave oven.

Failure to do so can result in back or other injury.

Tools and Parts

Tools Needed

Gather the required tools and parts before starting installation. Read and follow the instructions provided with any tools listed here.

- Measuring tape
- Drill
- Pencil
- 1/16" (2 mm) drill bit
- No. 2 Phillips screwdriver

Parts Supplied

The microwave drawer is preassembled.

- 1" (2.5 cm) mounting screws (4)

Materials needed

- 6" (15.2 cm) Anti-Tip block (installer to provide)

Location Requirements

The microwave drawer may be located in a cabinet or below the counter, and/or below a built-in oven. Check the opening where the microwave drawer will be installed. The location must provide:

- Wood cabinetry.
- Cutout opening that is plumb and square. See "Minimum Cutout Dimensions" in "Minimum Dimensions" section.
- Cutout floor that is solid, level and flush with bottom of cabinet cutout.
- Support for weight of at least 100 lbs (45.4 kg), which includes microwave oven and items placed inside.
- Grounded electrical outlet. See "Electrical Requirements" section.
- Minimum installation clearances for installation location. See "Minimum Dimensions" section.
- Complete enclosure around the recessed portion of the microwave drawer.

Minimum Dimensions

Minimum Installation Clearances

For proper installation, the following minimum clearances must exist above and below the cutout opening.

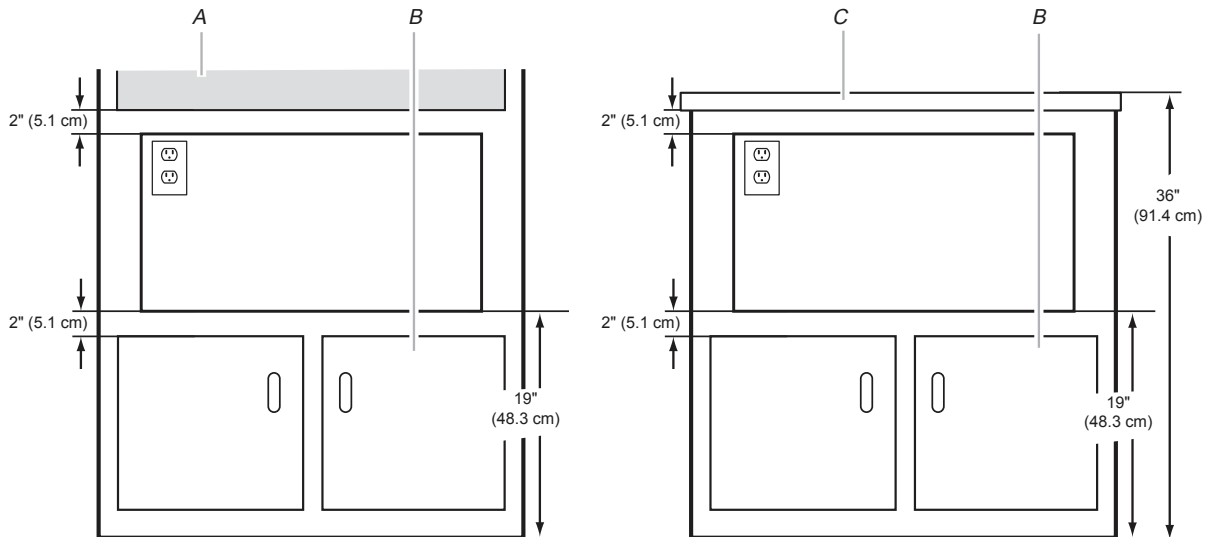

A. Upper oven
B. Lower cabinet
C. Counter

PRODUCT DIMENSIONS

Minimum Cutout Dimensions

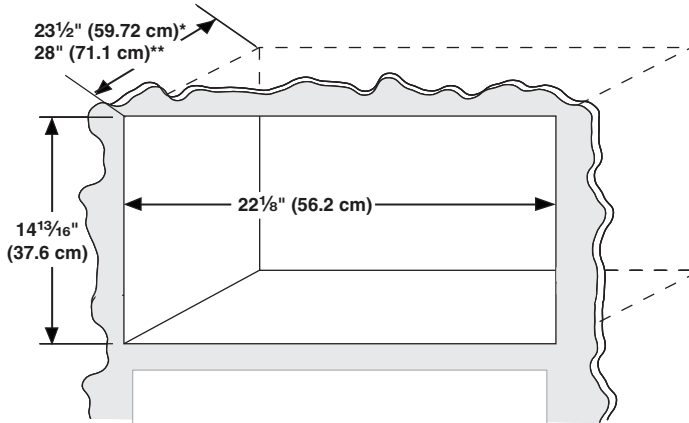

*With flush receptacle.

**With non-flush receptacle.

Width	22 1/8" (59.7 cm)
Height	14 13/16" (37.6 cm) for all installations
Depth	23 1/2" (59.7 cm) with flush receptacle; 28" (71.1 cm) with non-flush receptacle

Cutout Top View

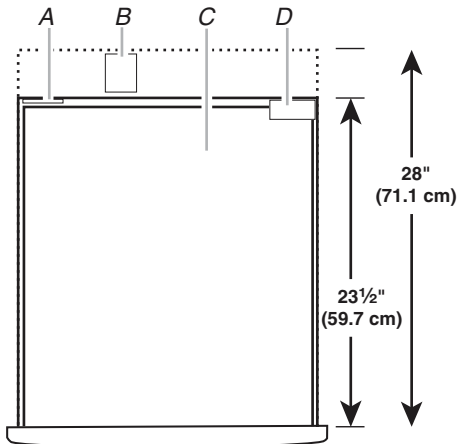

- A. Flush receptacle located in upper left corner only
- B. Non-flush receptacle
- C. Microwave drawer
- D. Anti-tip block located in upper right corner only

Product Dimensions

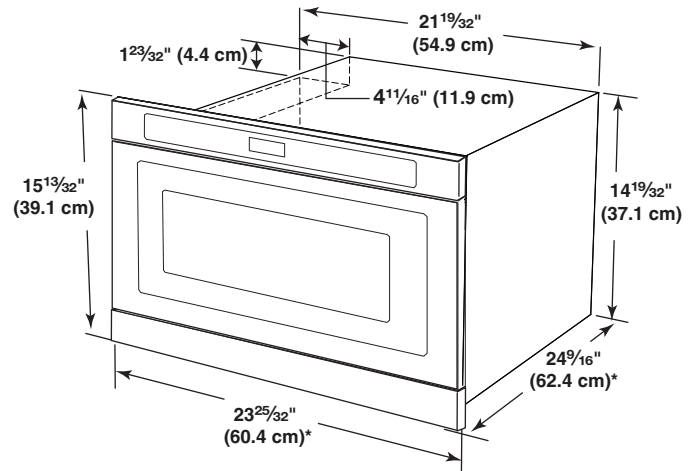

*Measurements include front facing of microwave drawer.

The drawer opens 15" (38.1 cm).

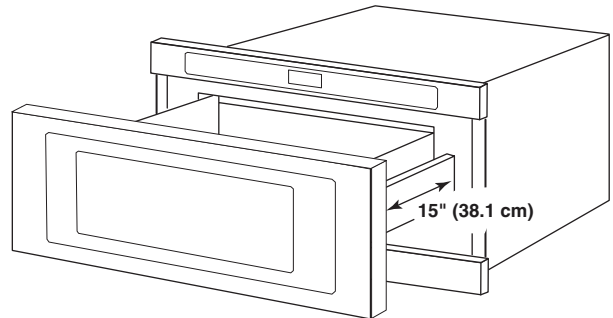

THEORY OF OPERATION

MICROWAVE OPERATING SEQUENCE

The following is a description of component functions during oven operation.

OFF CONDITION

Closing the drawer activates the door sensing switch and secondary interlock switch. (In this condition, the monitor switch contacts are opened.)

When oven is plugged in, 120 volts A.C. is supplied to the control unit.

1. The display will show flashing "Enjoy Your Drawer Touch Clear and Touch Clock".

To set any program or set the clock, you must first touch the STOP/CLEAR pad. The display will clear, and " : " will appear.

COOKING CONDITION

Program desired cooking time by touching the NUMBER pads. Program the power level by touching the POWER LEVEL pad and then a Number pad. When the START pad is touched, the following operations occur:

1. The contacts of relays are closed and components connected to the relays are turned on as follows.

RELAY	CONNECTED COMPONENTS
RY-1	oven lamp/stir fan motor/fan motor
RY-2	power transformer

2. 120 volts A.C. is supplied to the primary winding of the power transformer and is converted to about 3.3 volts A.C. output on the filament winding, and approximately 2370 volts A.C. on the high voltage winding.
3. The filament winding voltage heats the magnetron filament and the H.V. winding voltage is sent to a voltage doubler circuit.

4. The microwave energy produced by the magnetron is channelled through the waveguide into the cavity feedbox, and then into the cavity where the food is placed to be cooked.
5. Upon completion of the cooking time, the power transformer, oven lamp, etc. are turned off, and the generation of microwave energy is stopped. The oven will revert to the OFF condition.
6. When the drawer is opened during a cook cycle, the monitor switch, door sensing switch, secondary interlock switch, relay (RY1) and primary interlock relay are activated with the following results. The circuits to the stir fan motor, the cooling fan motor, and the high voltage components are de-energized, the oven lamp remains on, and the digital read-out displays the time still remaining in the cook cycle when the door was opened.
7. The monitor switch electrically monitors the operation of the secondary interlock switch and secondary interlock relay and is mechanically associated with the drawer so that it will function in the following sequence.
8. When the drawer opens from the closed position, the primary interlock relay (RY2) and secondary interlock switch open their contacts. And contacts of the relay (RY1) remains closed. Then the monitor switch contacts close.
9. When the drawer is closed from the open position, the monitor switch contacts open first. Then the contacts of the secondary interlock switch and door sensing switch close. And contacts of the relay (RY1) open.

If the secondary interlock switch and primary interlock relay (RY2) fail with the contacts closed when the drawer is opened, the closing of the monitor switch contacts will form a short circuit through the fuse, secondary interlock

switch, relay(RY1) and secondary interlock relay (RY2), causing the fuse to blow.

POWER LEVEL P-0 TO P-90 COOKING

When Variable Cooking Power is programmed, the 120 volts A.C. is supplied to the power transformer intermittently through the contacts of relay (RY-2) which is operated by the control unit within a 32 second time base. Microwave power operation is as follows:

VARI-MODE	ON TIME	OFF TIME
Power 10(P-HI)	32 sec.	0 sec.
(100% power)		
Power 9(P-90)	30 sec.	2 sec.
(approx. 90% power)		
Power 8(P-80)	26 sec.	6 sec.
(approx. 80% power)		
Power 7(P-70)	24 sec.	8 sec.
(approx. 70% power)		
Power 6(P-60)	22 sec.	10 sec.
(approx. 60% power)		
Power 5(P-50)	18 sec.	14 sec.
(approx. 50% power)		
Power 4(P-40)	16 sec.	16 sec.
(approx. 40% power)		
Power 3(P-30)	12 sec.	20 sec.
(approx. 30% power)		
Power 2(P-20)	8 sec.	24 sec.
(approx. 20% power)		
Power 1(P-10)	6 sec.	26 sec.
(approx. 10% power)		
Power 0(P-0)	0 sec.	32 sec.
(0% power)		

Note: The ON/OFF time ratio does not correspond with the percentage of microwave power, because approximately .2 seconds are needed for heating of the magnetron filament.

SENSOR COOKING CONDITION

Using the SENSOR function, food is cooked without figuring time, power level or quantity. When the oven senses enough steam from the food, it relays the information to its micro-processor which will calculate the remaining cooking time and power level needed for best results. When the food is cooked, water vapor is developed. the sensor "senses" the vapor and its resistance increase gradually. When the resistance reaches the value set according to the menu, supplementary cooking is started. The time of supplementary cooking is determined by experiment with each food category and inputted into the LSI. An example of how sensor works: (Potatoes)

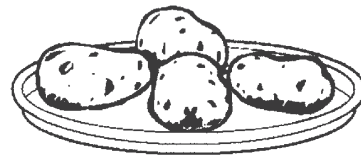

1. Potatoes at room temperature. Vapor is emitted very slowly.

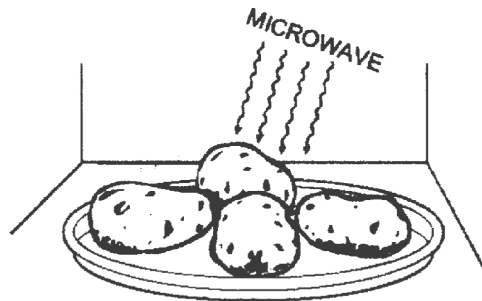

2. Heat Potatoes. Moisture and humidity is emitted very rapidly. You can smell the aroma as it cooks.

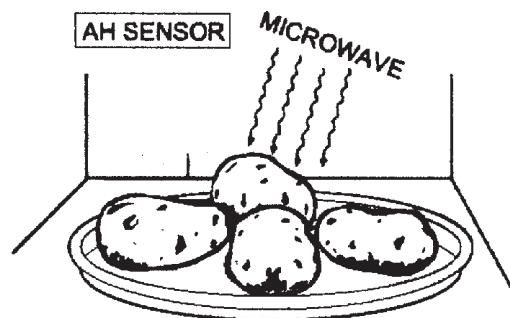

3. Sensor detects moisture and humidity and calculates cooking time and variable power.

Cooking Sequence

1. Touch one of the SENSOR pads.

NOTE: The oven should not be operated on sensor immediately after plugging in the unit. Wait two minutes before cooking on SENSOR.

2. The coil of shut-off relay (RY-1) is energized, but the power transformer is not turned on.
3. After about 16 seconds, the cook relay(RY-2) is energized. The power transformer is turned on, microwave energy is produced and first stage is started.

The 16 seconds is the cooling time required to remove any vapor from the oven cavity and sensor.

NOTE: During this first stage, do not open the drawer or touch STOP/CLEAR pad.

4. When the sensor detects the vapor emitted from the food, the display switches over to the remaining cooking time and the timer counts down to zero.
At this time, the drawer may be opened to stir, turn or season food.
5. When the timer reaches zero, an audible signal sounds. The shut-off relay and cook relay are de-energized and the power transformer, oven lamp, etc. are turned off.
6. Opening the drawer or touching the STOP/CLEAR pad, the time of the day will reappear on the display and the oven will revert to an OFF condition. When the timer reaches zero, an audible signal sounds.

THE ABSOLUTE HUMIDITY (AH) SENSOR CIRCUIT

(1) Structure of Humidity Sensor

The humidity sensor includes two thermistors as shown in the illustration. One thermistor is housed in the closed vessel filled with dry air while another in the open vessel.

Each sensor is provided with the protective cover made of metal mesh to be protected from the external airflow.

Ventilation Opening for Sensing

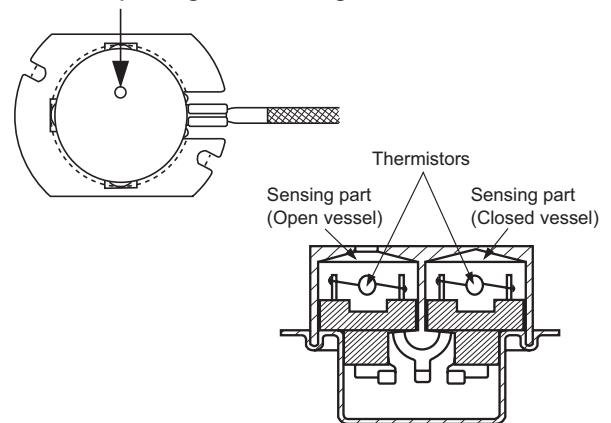

(2) Operational Principle of Humidity Sensor

The figure below shows the basic structure of an absolute humidity sensor. A bridge circuit is formed by two thermistors and two resistors (R1 and R2). The output of the bridge circuit is to be amplified by the operational amplifier. Each thermistor is supplied with a current to keep it heated at about 150°C (302°F), the resultant heat is dissipated in the air and if the two thermistors are placed in different humidity conditions they show different degrees of heat conductivity leading to a potential difference between them causing an output voltage from the bridge circuit, the intensity of which is increased as the absolute humidity of the air increases. Since the output is varied every minute, it is amplified by the operational amplifier.

THE ABSOLUTE HUMIDITY (AH) SENSOR CIRCUIT (cont'd)

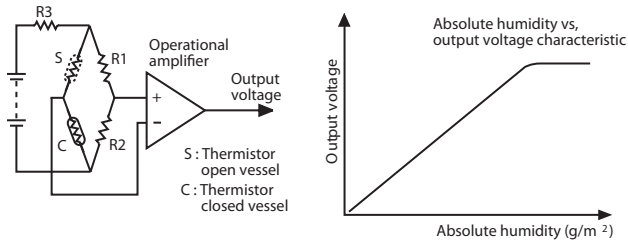

(3) Detector Circuit of Humidity Sensor Circuit

This detector circuit is used to detect the output voltage of the absolute humidity circuit to allow the LSI to control sensor cooking of the unit. When the unit is set in the sensor cooking mode, 16 seconds clearing cycle occurs than the detector circuit starts to function and the LSI observes the initial voltage available at its AN6 terminal.

With this voltage given, the switches SW1 to SW5 in the LSI are turned on in such a way as to change the resistance values in parallel with R45 ~ R49. Changing the resistance values results in that there is the same potential at both F-3 terminal of the absolute humidity sensor and AN6 terminal of the LSI. The voltage of AN7 terminal will indicate about +2.5V. This initial balancing is set up about 16 seconds after the unit is put in the Sensor Cooking mode. As the sensor cooking proceeds, the food is heated to generate

moisture by which the resistance balance of the bridge circuit is deviated to increase the voltage available at AN6 terminal of the LSI. Then the LSI observes that voltage at AN7 terminal and compares it with its initial value, and when the comparison rate reaches the preset value (fixed for each menu to be cooked), the LSI causes the unit to stop sensor cooking; thereafter, the unit goes in the next operation automatically.

When the LSI starts to detect the initial voltage at AN7 terminal 16 seconds after the unit has been put in the Sensor Cooking mode, if it is not possible to balance the bridge circuit due to disconnection of the absolute humidity sensor, ERROR will appear on the display and the cooking is stopped.

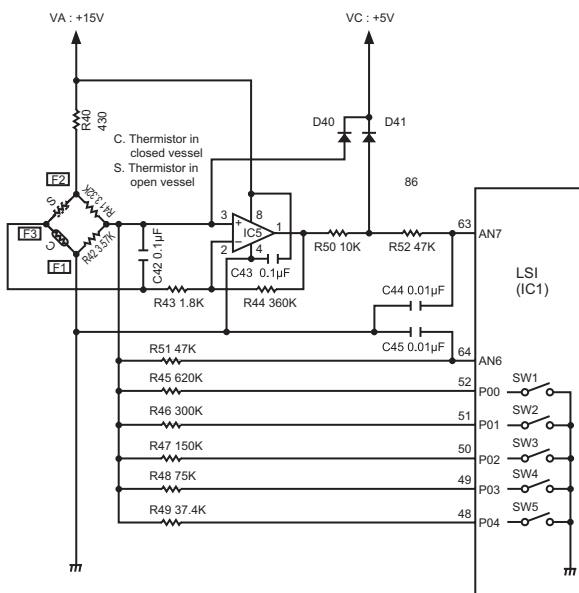

SCHEMATIC (OFF CONDITION)

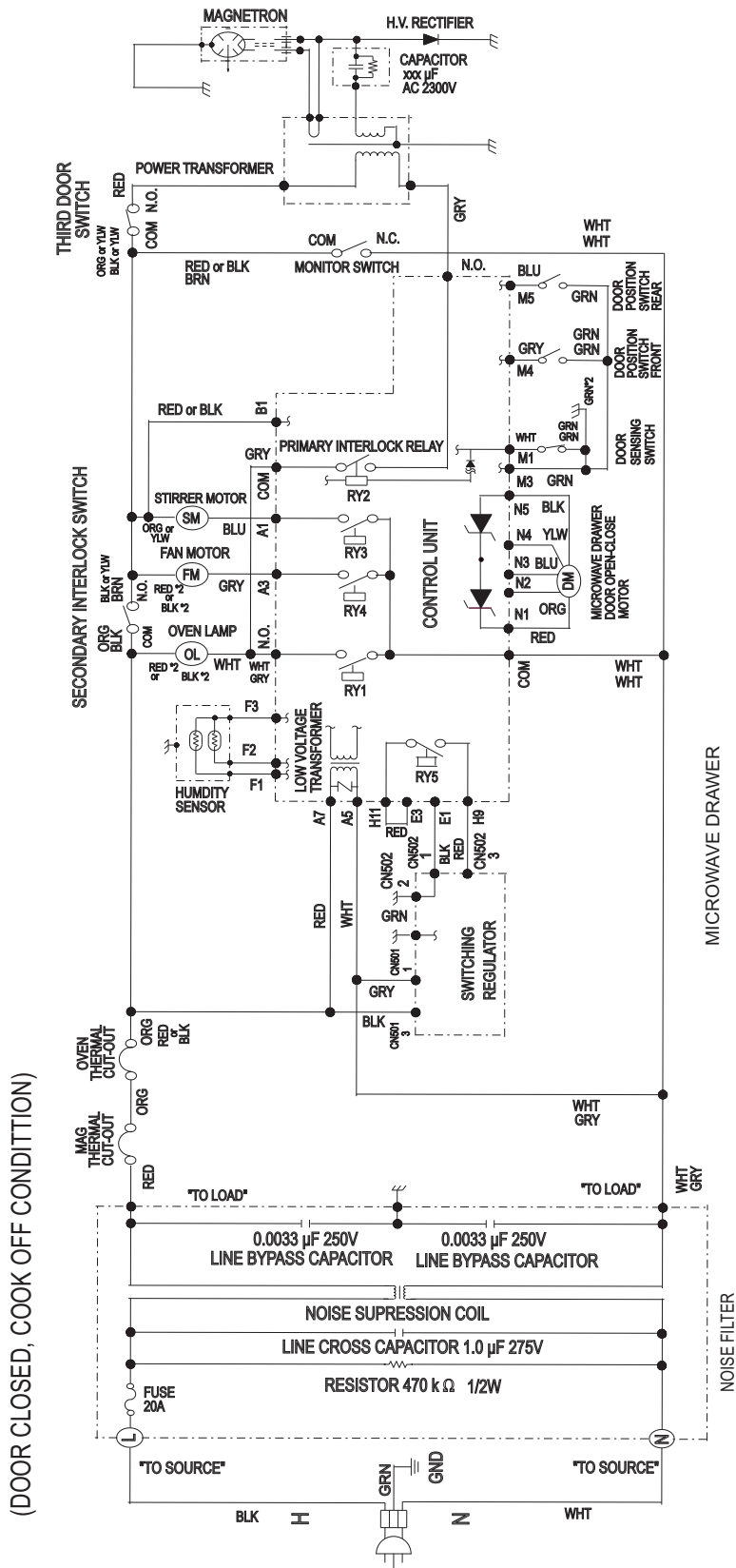

- NOTES:
1. Circuits / Wire Colors subject to change without notice.
 2. Terminal that is located on the right side on lamp socket's back view must be connected to neutral wire.
 3. Only certain models use the absolute humidity sensor.
 4. Power Transformer (Finish Lead) terminal must be connected to Hot wire (RED)

- NOTES -

COMPONENT ACCESS

This section instructs you on how to service each component inside the Microwave Drawer. The components and their locations are shown below.

⚠ WARNING



Electrical Shock Hazard
Disconnect power before servicing.
Replace all parts and panels before operating.
Failure to do so can result in death or electrical shock.

COMPONENT LOCATIONS

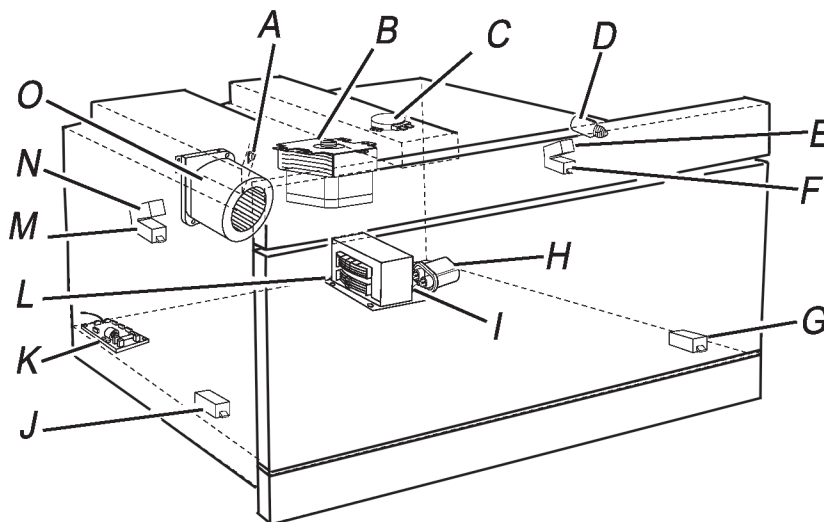

- | | | |
|------------------------|---------------------------------|-------------------------------|
| A. Cavity thermostat | F. Drawer sensing switch | K. AC line filter |
| B. Magnetron | G. Door position switch (front) | L. H.V. transformer |
| C. Stirrer motor | H. H.V. capacitor | M. Secondary interlock switch |
| D. Cavity light | I. H.V. diode | N. Monitor interlock switch |
| E. Third drawer switch | J. Door position switch (rear) | O. Cooling fan motor |

ACCESSING INTERNAL COMPONENTS

⚠ WARNING



Electrical Shock Hazard
Disconnect power before servicing.
Replace all parts and panels before operating.
Failure to do so can result in death or electrical shock.

1. Unplug microwave drawer or disconnect power.
2. Before removing Microwave Drawer, take measures to protect the Drawer trim by either removing the trim or by letting the trim over hang off flat protected surface (see figure 1).
3. Open the Drawer to access the 4 mounting screws holding the unit on to the wall or cabinet opening, see figure 1.

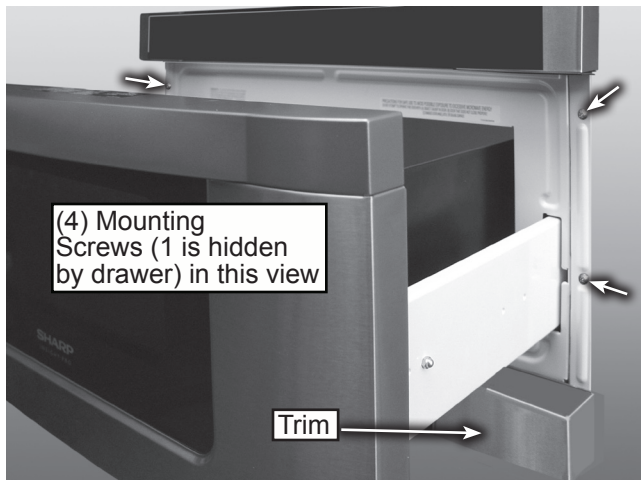

Figure 1

4. Close Drawer and pull the unit out from opening and unplug the power supply cord.
5. Remove top cover, see figure 2.



Figure 2

6. Remove air cover from back of unit, then both side panels. (figures 3 & 4).

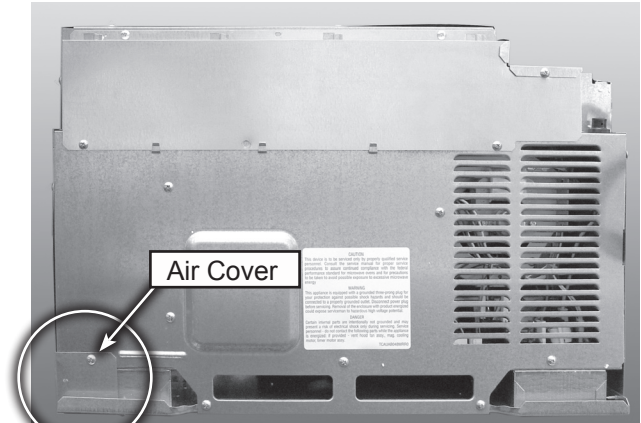

Figure 3

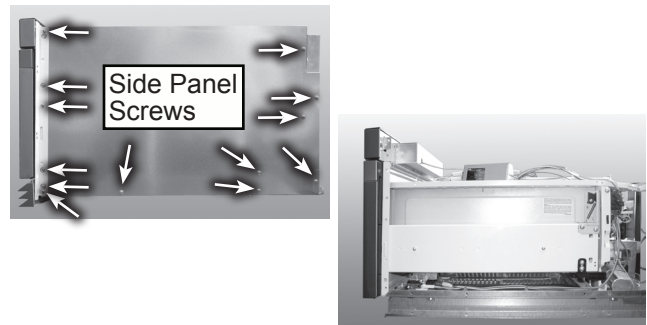

Figure 4

(Remove both side panels, right side is shown)

ACCESSING INTERNAL COMPONENTS (continued)

7. Remove exhaust duct and back cover (see figures 5 & 6).

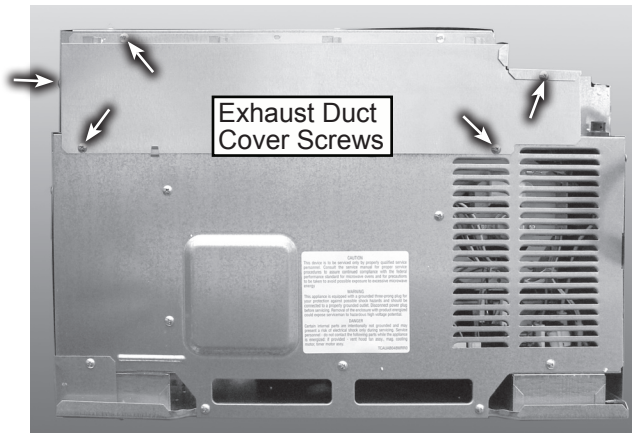

Figure 5

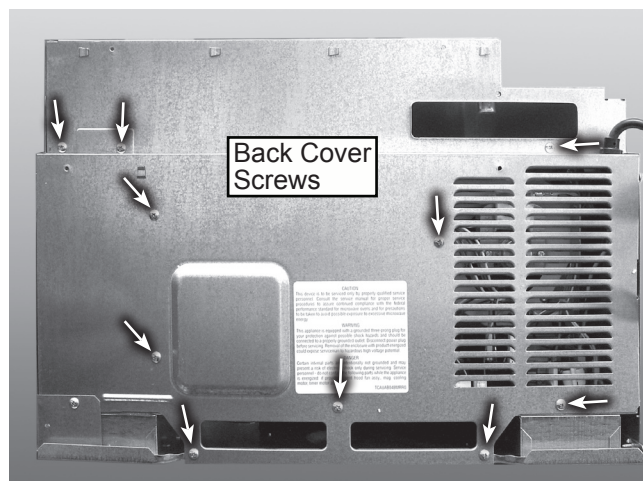

Figure 6

7. To remove the Control Panel Assembly, remove the top panel as outlined in step 5 in this section.
8. Remove (2) screws on each end on the back of the control panel, see figure 7.



Figure 7

9. Unsnap the top control panel assembly from the frame and drop down to the front of the microwave, see figure 8.
10. Unplug all wires. The frame and Power Control Board can now be serviced, see figure 8.

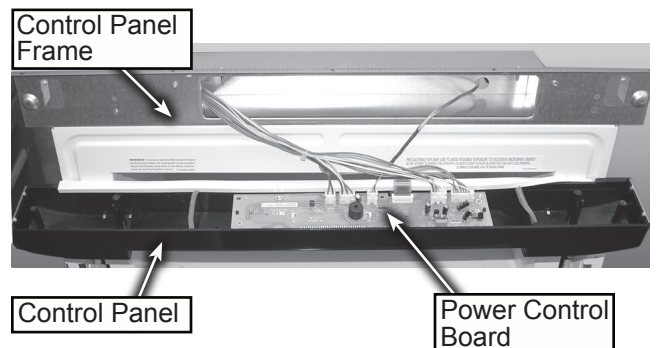

Figure 8

REMOVING THE POWER CORD

⚠ WARNING



Electrical Shock Hazard

Disconnect power before servicing.

Replace all parts and panels before operating.

Failure to do so can result in death or electrical shock.

1. Unplug microwave drawer or disconnect power.
2. Follow procedures to remove the back panel as outlined in the steps under "ACCESSING INTERNAL COMPONENTS" pages 4-2 and 4-3.
3. Un-hook the black and white AC terminals from the Noise Filter and green ground wire from the back plate, see figure 1 & 2.

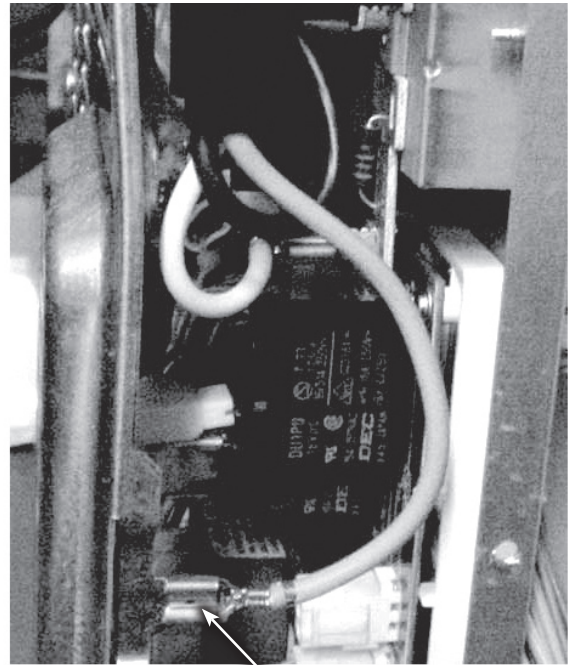

Un-hook Ground to metal Tab on Back Panel

Figure 2

NOTE: The green ground wire terminal can be attached when reassembling the back plate to the drawer cavity.

Un-hook Black AC Wire to Top Terminal

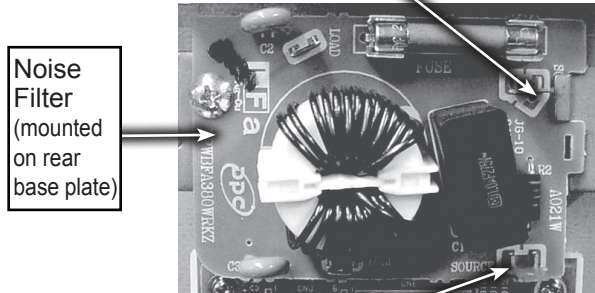

Un-hook White AC Wire to Bottom Terminal

Figure 1

4. Attach the black and white AC terminals from the new Power Cord to the Noise Filter as shown in figure 1.

REMOVING THE SECONDARY INTERLOCK SWITCH, MONITOR SWITCH AND FRONT AND REAR DOOR SWITCH

⚠ WARNING



Electrical Shock Hazard
Disconnect power before servicing.
Replace all parts and panels before operating.
Failure to do so can result in death or electrical shock.

1. Unplug microwave drawer or disconnect power.
2. Follow procedures to remove the side panels as outlined in the steps under "ACCESSING INTERNAL COMPONENTS" pages 4-2 and 4-3.
3. Discharge the high voltage capacitor terminals with a 20,000 Ω 2 watt resistor to chassis ground.
4. Remove the screw holding the latch hook to the oven flange, see figure 1.

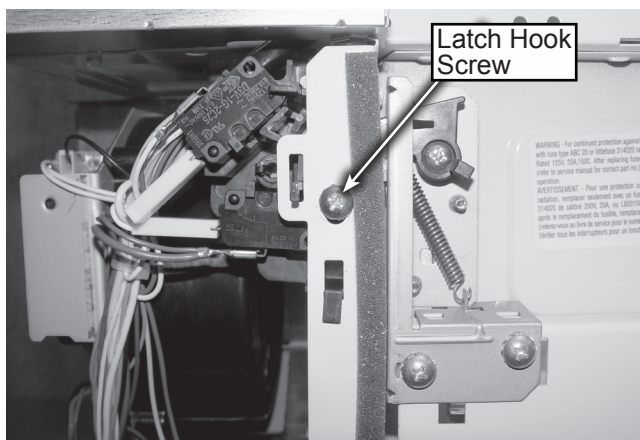

Figure 1

5. Remove the latch hook from the oven flange.

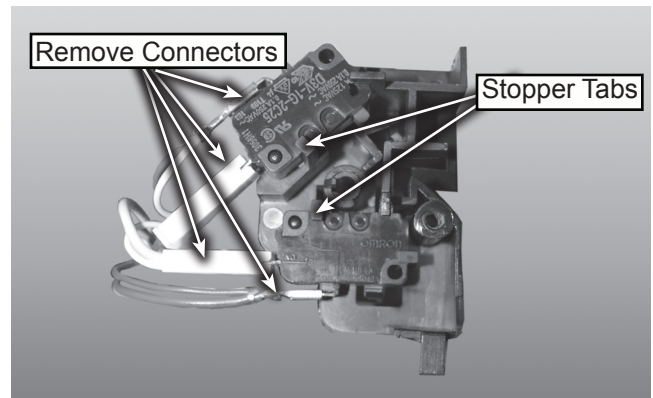

Figure 2

6. Disconnect the wire leads of each switch.
7. Remove each switch from the latch hook by pushing the stopper tabs holding each switch, see figure 2.

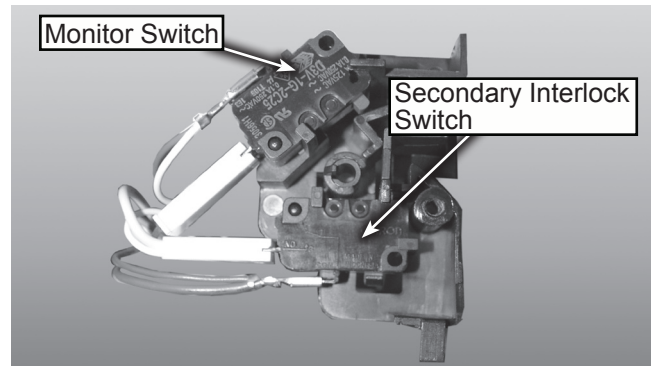

Figure 3

NOTE: Figure 3 switches are mounted on the left side of the microwave.

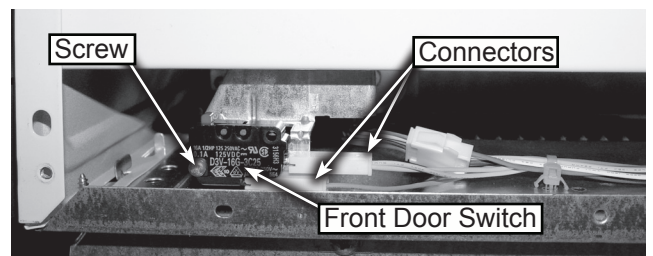

Figure 4

8. The front door switch is located behind the side panel on the right side of the microwave, see figure 4.
9. Remove the connectors and one screw to replace, see figure 4.

Continued on the next page

REMOVING THE SECONDARY INTERLOCK SWITCH, MONITOR SWITCH AND FRONT AND REAR DOOR SWITCH (continued)

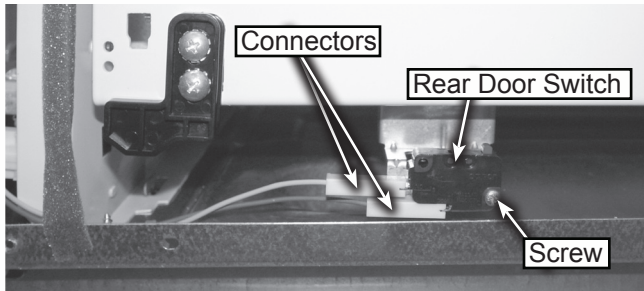

Figure 5

- 8. The rear door switch is located behind the side panel on the left side of the microwave, see figure 4.
- 9. Remove the connectors and one screw to replace, see figure 5.

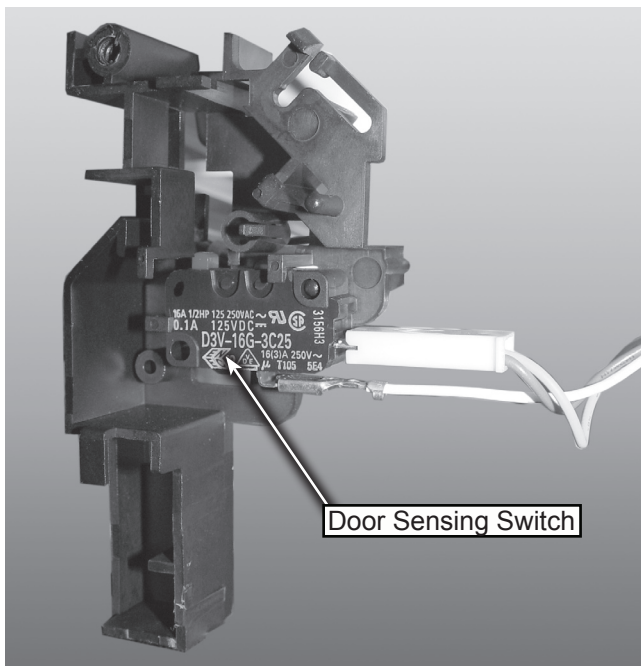

Figure 6

NOTE: This switch is mounted on the right side of the microwave. The switch is accessed in a similar manner as the left side as described in removal steps on pages 4-4 and 4-5.

Re-install

- 1. Re-install each switch in its place. The secondary interlock switch is in the lower position and the monitor switch is in the top position, located on the left side of the unit, see figure 3.

The door sensing switch by itself on the right side of the unit, see figure 4.

- 2. Re-connect wire leads to each switch. Refer to pictorial diagram.

NOTE: Reinstall the switch assembly bracket and then connect the wires to the switch terminals. Use the correct diagram to make sure of your connections.

- 3. Secure the latch hooks with mounting screws to oven flange.
- 4. Make sure that the monitor switch is operating properly and check continuity of the monitor circuit.

REMOVING THE OVEN LAMP

⚠ WARNING



Electrical Shock Hazard
Disconnect power before servicing.
Replace all parts and panels before operating.
Failure to do so can result in death or electrical shock.

1. Unplug microwave drawer or disconnect power.
2. Remove the microwave drawer from the cabinet.
3. Remove one screw securing the access panel to the right front top of the microwave. The access panel is held in place by two tabs that engage two slots toward the rear, see figure 1.

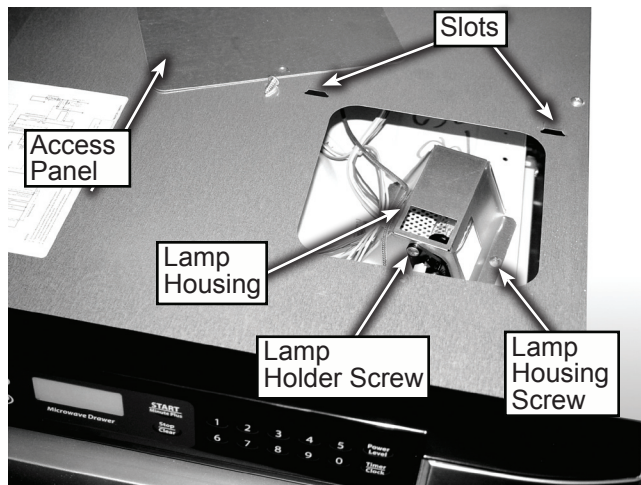

Figure 1

4. To replace the oven lamp or lamp holder: Remove one screw securing the lamp housing to the top of the microwave, see figure 1.
5. Disengage the tab on the opposite side of the housing to access the lamp and lamp holder, see figure 2.

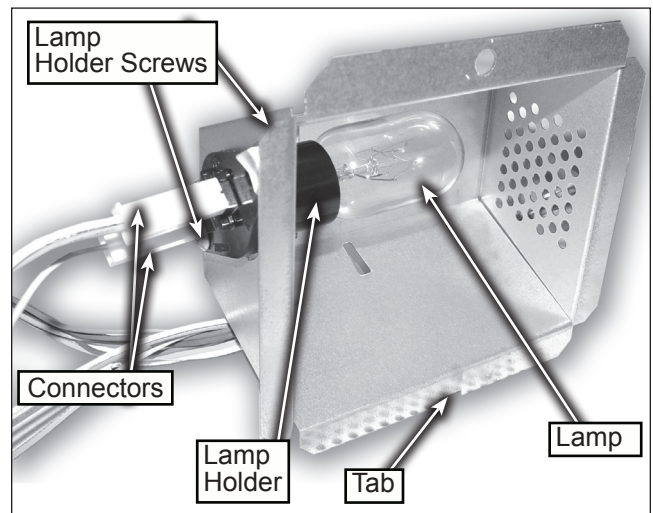

Figure 2

6. Unscrew the lamp and replace, see figure 2.

REMOVING THE DRAWER ASSEMBLY

1. Open drawer and extend it fully.
2. Locate the drawer support cover on the back of the frame on both sides of the Drawer Assembly.
3. Using a putty knife gently pry on the side of the cover until it snaps out, see figure 1.

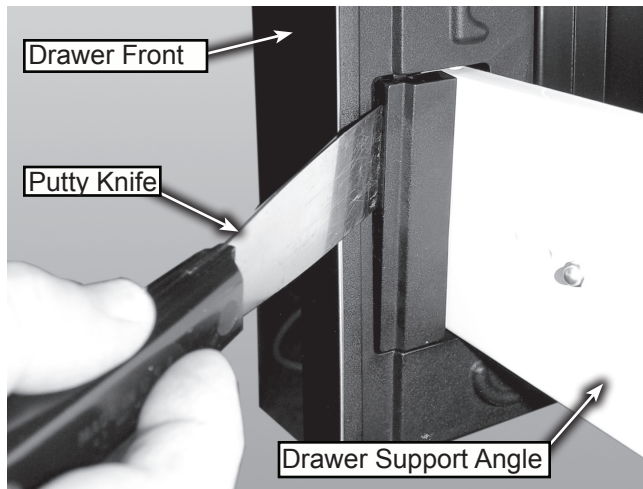

Figure 1

4. Remove two screws on either side of the drawer support angles securing the drawer, see figure 2.

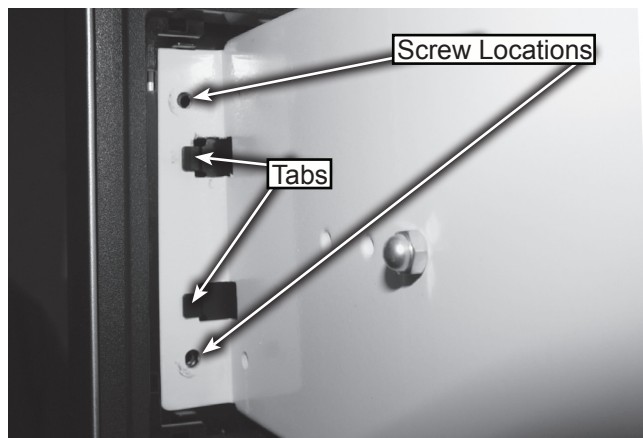

Figure 2

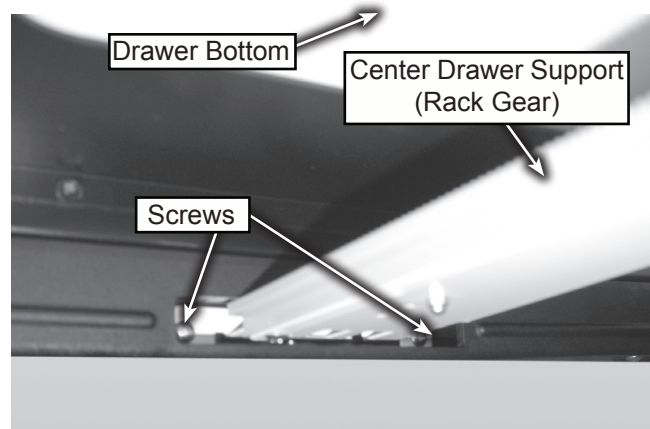

Figure 3

5. Once all screws are removed, release the side support angles by pulling the angles out slightly to clear the tabs. Lift and remove the drawer assembly see figure 2.



Figure 4

6. With the Drawer removed, the oven cavity can easily be serviced. see figure 4.

REMOVING THE STIRRER COVER AND STIRRER FAN ASSEMBLIES

1. Remove the Drawer Assembly, see Removing the Drawer Assembly page 4-8.
2. Remove the two canoe clips that secure the front of the stirrer cover. These clips are removed by gently prying them from their mounting holes, see figure1.
3. Disengage the Stirrer Cover Assembly notches from the tabs in the microwave top at the rear, see figure 1. The cover will drop and the Stirrer Fan will be accessible, see figure2.

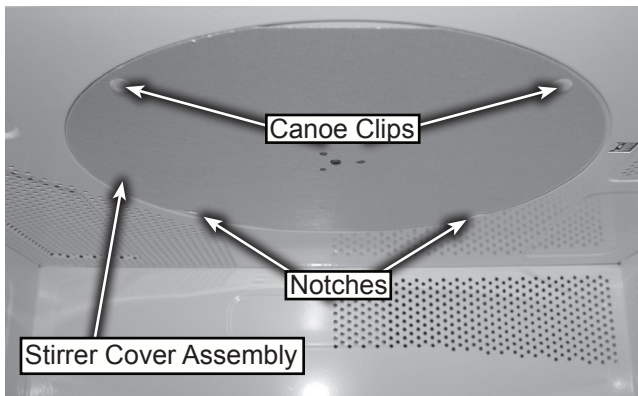

Figure 1

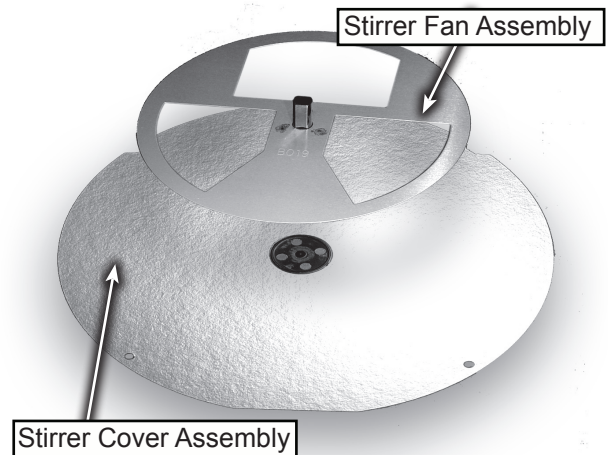

Figure 2

4. Remove the Stirrer Fan Assembly.
5. Reassemble in reverse order making sure to not damage the Canoe Clips as it is necessary to reuse these clips to resecure the Stirrer Cover Assembly.

REMOVING THE STIRRER MOTOR

⚠ WARNING



Electrical Shock Hazard

Disconnect power before servicing.

Replace all parts and panels before operating.

Failure to do so can result in death or electrical shock.

1. Unplug microwave drawer or disconnect power.
2. Remove the microwave drawer from the cabinet. (see page 4-2 for the procedure).
3. Remove the top panel. (see page 4-2 figure 2.)

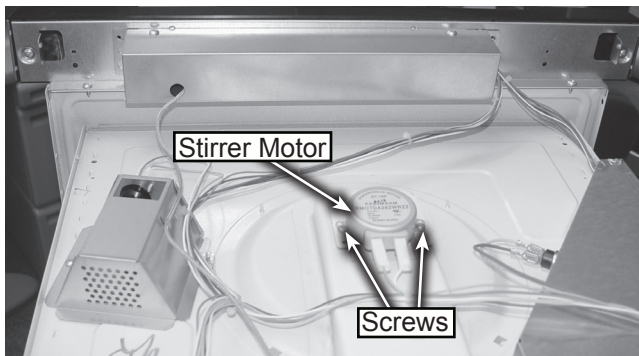

Figure 1

4. Remove two screws securing the stirrer motor, see figure 1.

5. Disengage two tabs on the bracket from the mounting holes in the motor, see figure 2.
6. Remove two connectors and replace motor, see figure 2.

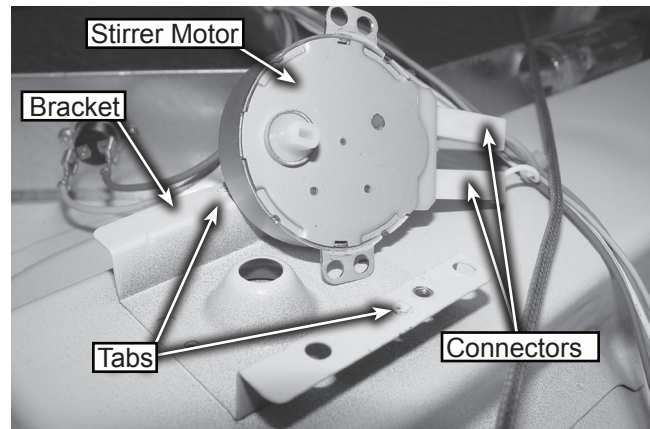

Figure 2.

7. Be sure to reattach the stirrer fan assembly to the motor. This may require performing the procedures outlined in steps 1-5 on page 4-9 Removing the Stirrer Cover and Stirrer Fan Assemblies.

REMOVING THE HUMIDITY SENSOR

⚠ WARNING



Electrical Shock Hazard
Disconnect power before servicing.
Replace all parts and panels before operating.
Failure to do so can result in death or electrical shock.

1. Unplug microwave drawer or disconnect power.
2. Remove the microwave drawer from the cabinet. (see page 4-2 for the procedure).
3. Remove the top panel. (see page 4-2 figure 2.)

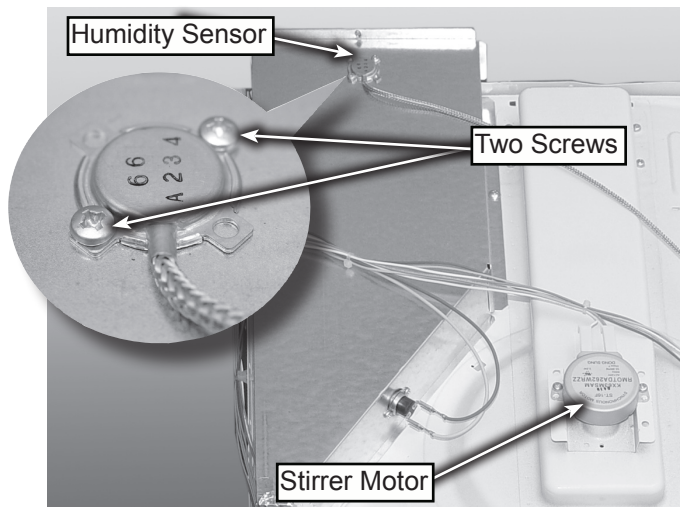

Figure 1
(left rear with the top panel removed)

4. Remove two screws securing the humidity sensor to the microwave top, see figure 1.
5. Disconnect the connector with the shielded black red and white wires from the control PCB at location CNF, see figure 2.

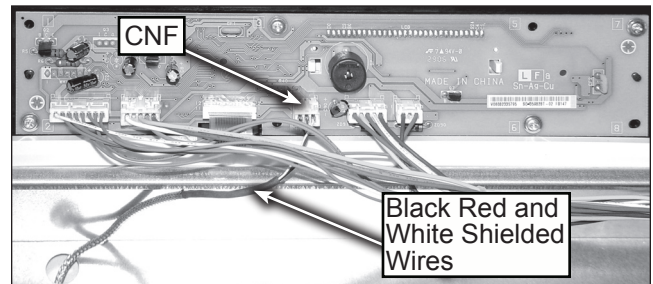

Figure 2

INTERIOR COMPONENTS LOCATIONS

⚠ WARNING



Electrical Shock Hazard
Disconnect power before servicing.
Replace all parts and panels before operating.
Failure to do so can result in death or electrical shock.

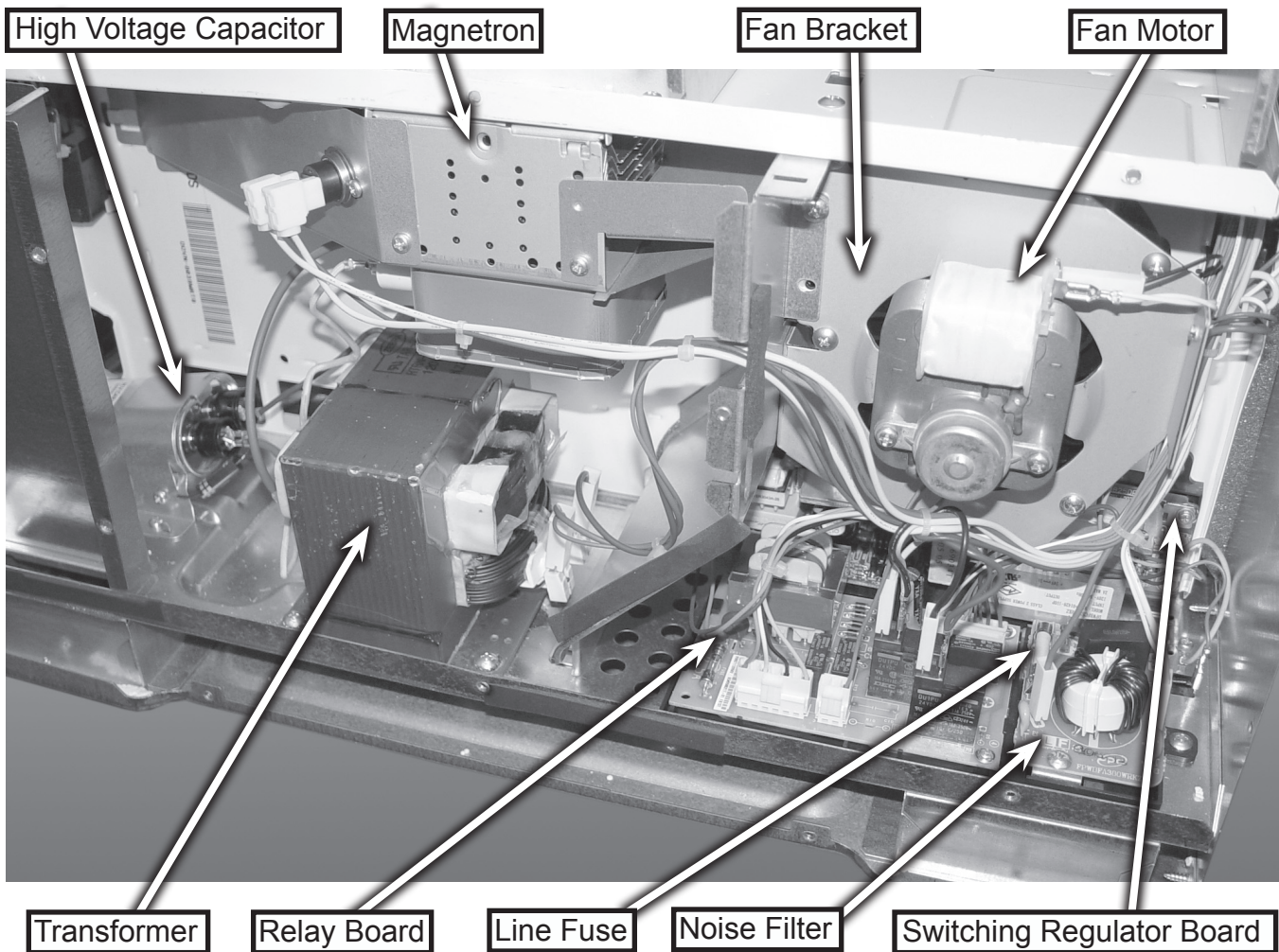

REMOVING THE HIGH VOLTAGE CAPACITOR AND DIODE

⚠ WARNING



Electrical Shock Hazard
Disconnect power before servicing.
Replace all parts and panels before operating.
Failure to do so can result in death or electrical shock.

1. Unplug microwave drawer or disconnect power.
2. Remove the microwave drawer from the cabinet as outlined in steps 1-4 of Accessing Internal Components (see page 4-2 for the procedure).
3. Remove the top, side and back panels as outlined in the steps Accessing Internal Components (see page 4-2 and 4-3 for the procedure).
4. Discharge the high voltage capacitor terminals with a 20,000 Ω 2 watt resistor to chassis ground.

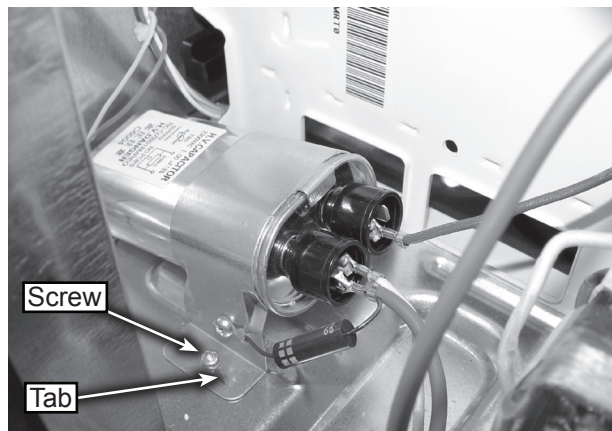

Figure 1

5. Remove one screw and disengage the capacitor mounting bracket from the tab on the microwave base, see figure 1.

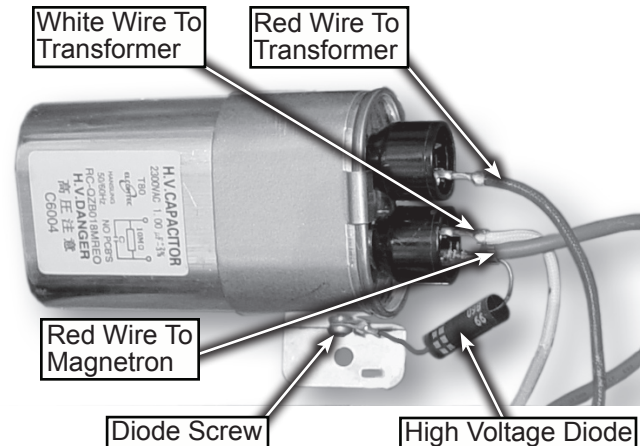

Figure 2

6. Remove the mounting screw from the capacitor bracket and diode ring terminal, see figure 2.
7. Disconnect the diode wire from the magnetron terminal and remove the diode.
8. Reassemble in reverse order.

REMOVING THE HIGH VOLTAGE TRANSFORMER

⚠ WARNING



Electrical Shock Hazard

Disconnect power before servicing.

Replace all parts and panels before operating.

Failure to do so can result in death or electrical shock.

1. Unplug microwave drawer or disconnect power.
2. Remove the microwave drawer from the cabinet as outlined in steps 1-4 of Accessing Internal Components (see page 4-2 for the procedure).
3. Remove the top, side and back panels as outlined in the steps Accessing Internal Components (see page 4-2 and 4-3 for the procedure).
4. Discharge the high voltage capacitor terminals with a 20,000 Ω 2 watt resistor to chassis ground.

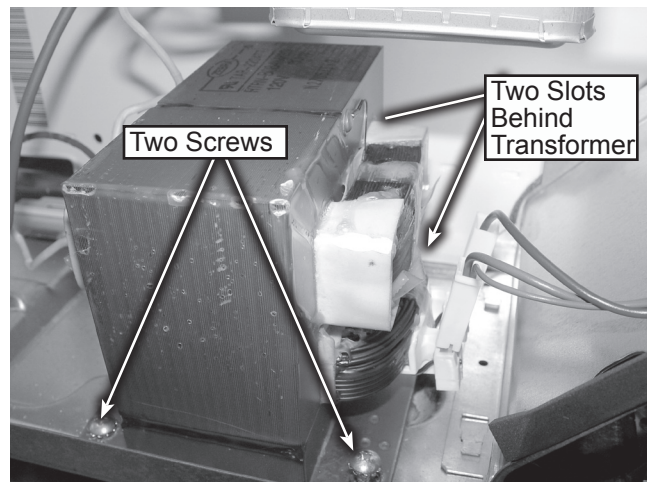

Figure 1

5. Remove two screws securing the base of the transformer to the microwave.
6. Disengage two tabs from the slots at the rear of the transformer on the microwave base.
7. Remove connections and replace the transformer.

REMOVING THE MAGNETRON

⚠ WARNING



Electrical Shock Hazard
Disconnect power before servicing.
Replace all parts and panels before operating.
Failure to do so can result in death or electrical shock.

1. Unplug microwave drawer or disconnect power.
2. Remove the microwave drawer from the cabinet as outlined in steps 1-4 of Accessing Internal Components (see page 4-2 for the procedure).
3. Remove the top, side and back panels as outlined in the steps Accessing Internal Components (see page 4-2 and 4-3 for the procedure).
4. Discharge the high voltage capacitor terminals with a 20,000 Ω 2 watt resistor to chassis ground.

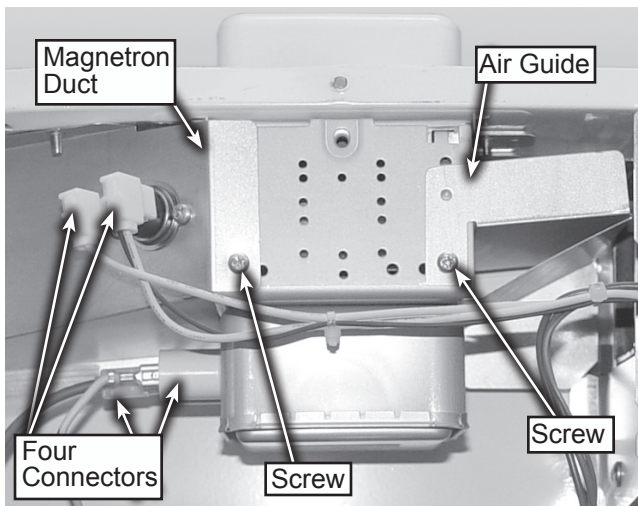

5. Remove the high voltage transformer, (see steps 1-7 on page 4-14). This step is necessary to provide clearance for magnetron removal.

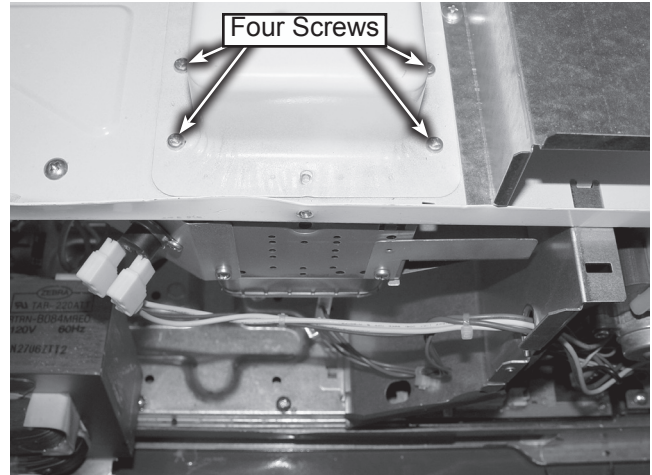

Figure 2

6. Remove four connectors.
7. Remove one screw that secures the magnetron to the magnetron air guide, see figure 1.
8. Remove one screw that secures the magnetron to the magnetron duct, see figure 1.
9. Remove the four screws that secure the magnetron to the microwave from the top.
10. Drop the magnetron down and replace or repair.

REMOVING THE COOLING FAN ASSEMBLY

⚠ WARNING



Electrical Shock Hazard

**Disconnect power before servicing.
Replace all parts and panels before
operating.**

**Failure to do so can result in death or
electrical shock.**

1. Unplug microwave drawer or disconnect power.
2. Remove the microwave drawer from the cabinet as outlined in steps 1-4 of Accessing Internal Components (see page 4-2 for the procedure).
3. Remove the top, side and back panels as outlined in the steps Accessing Internal Components (see page 4-2 and 4-3 for the procedure).
4. Discharge the high voltage capacitor terminals with a 20,000 Ω 2 watt resistor to chassis ground.

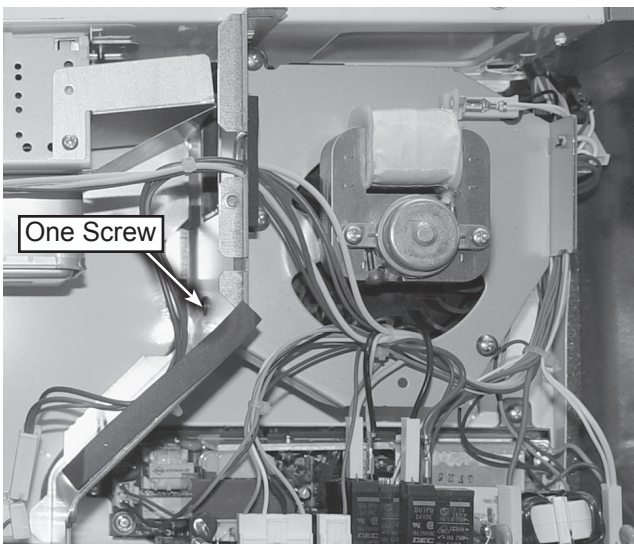

Figure 1

5. Remove one screw from the fan motor angle that secures the fan motor assembly, see figure 1.

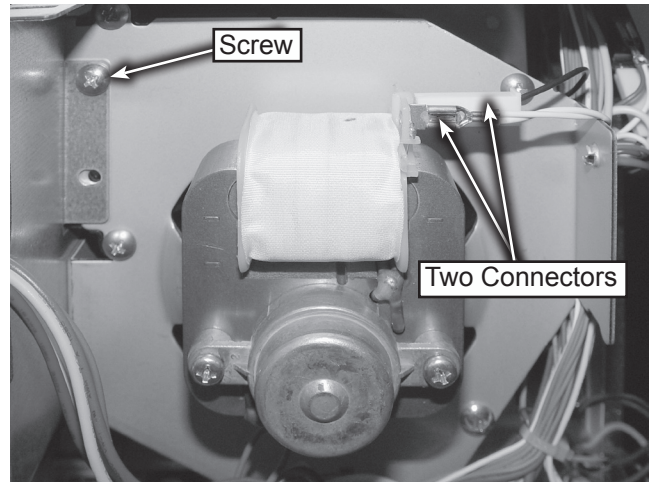

Figure 2

6. Disconnect two connectors, white wires from the front terminal and black wire from the back terminal, see figure 2.
7. Remove one screw from the inside of fan motor angle, this will release the housing and allow the fan motor assembly to be removed, see figure 2.

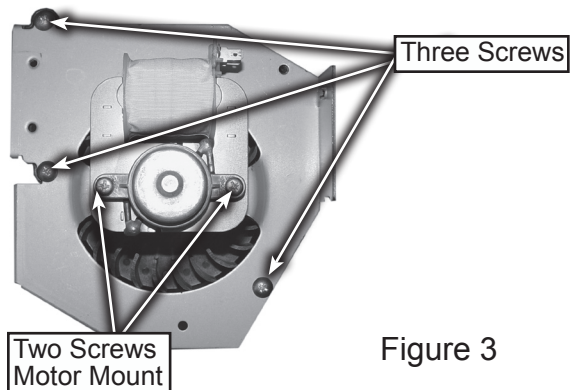

Figure 3

8. Remove three screws that attach the fan plenum to the fan motor assembly, see figure 3.
9. Remove the "E" clip securing the fan blade, see figure 4.

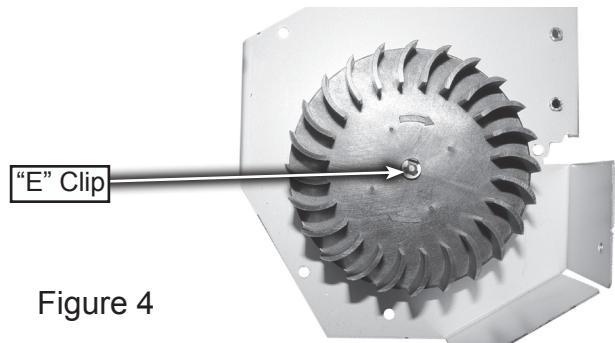

Figure 4

REMOVING THE RELAY, NOISE FILTER AND POWER SUPPLY BOARDS

⚠ WARNING



Electrical Shock Hazard
Disconnect power before servicing.
Replace all parts and panels before operating.
Failure to do so can result in death or electrical shock.

1. Unplug microwave drawer or disconnect power.
2. Remove the microwave drawer from the cabinet as outlined in steps 1-4 of Accessing Internal Components (see page 4-2 for the procedure).
3. Remove the top, side and back panels as outlined in the steps Accessing Internal Components (see page 4-2 and 4-3 for the procedure).
4. Discharge the high voltage capacitor terminals with a 20,000 Ω 2 watt resistor to chassis ground.

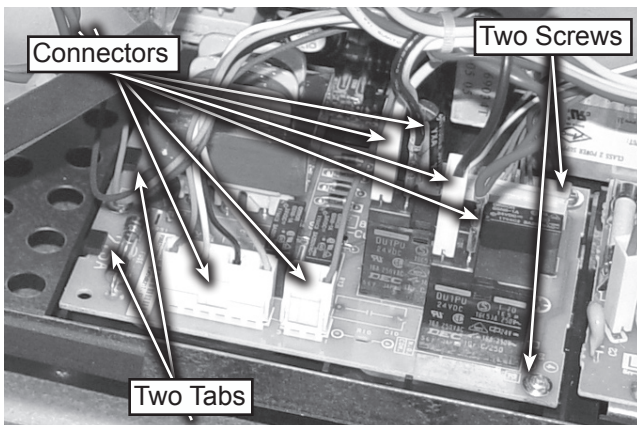

Figure 1

Relay Board

5. Disconnect six connectors from the relay board, see figure 1.

6. Remove two screws that secure the relay board to the microwave, see figure 1.
7. Disengage two tabs that hold the board in place, see figure 2.

Noise Filter Board

8. Remove one screw that secures the noise filter board to the microwave, see figure 1.
9. Remove four connectors.
10. Disengage one tab that holds the board in place, see figure 2.

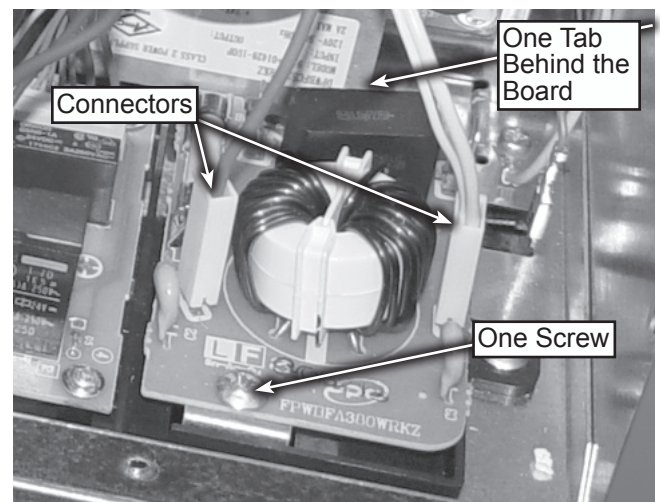

Figure 2

Switching Regulator Board

11. Remove the noise filter board to allow access to the switching regulator board, see figure 2.
12. Remove four connectors on the noise filter board.
13. Remove two screws that attach the board to the back wall of the microwave, see figure 3.

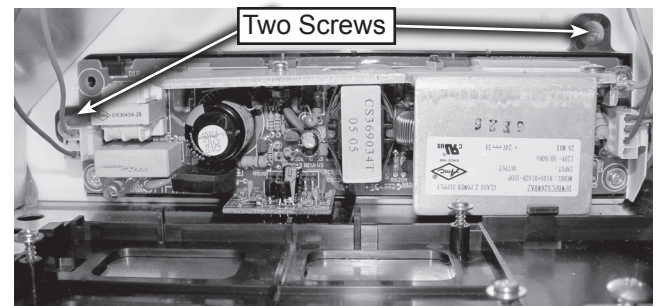



Figure 3

REMOVING THE AUTO DRAWER GEAR

⚠ WARNING



Electrical Shock Hazard

Disconnect power before servicing.

Replace all parts and panels before operating.

Failure to do so can result in death or electrical shock.

1. Unplug microwave drawer or disconnect power.
2. Remove the microwave drawer from the cabinet as outlined in steps 1-4 of Accessing Internal Components (see page 4-2 for the procedure).
3. Remove the top and right side panels as outlined in the steps Accessing Internal Components (see page 4-2 and 4-3 for the procedure).
4. Discharge the high voltage capacitor terminals with a 20,000 Ω 2 watt resistor to chassis ground.

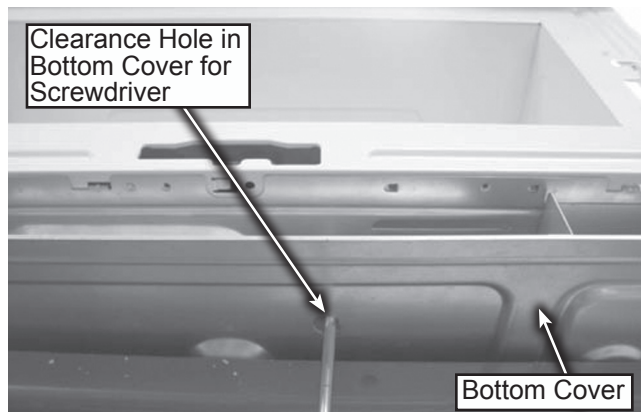

Figure 1a

5. Open the drawer and keep it open.
6. Unhook wiring to Auto Drawer Gear.
7. Remove bottom screw below Auto Drawer Gear, see figure 1a and 1b.

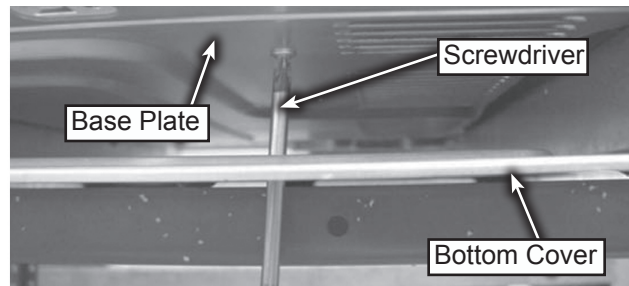

Figure 1b

8. Remove the (4) screws holding the auto drawer gear to the bottom cavity angle, see figure 2.

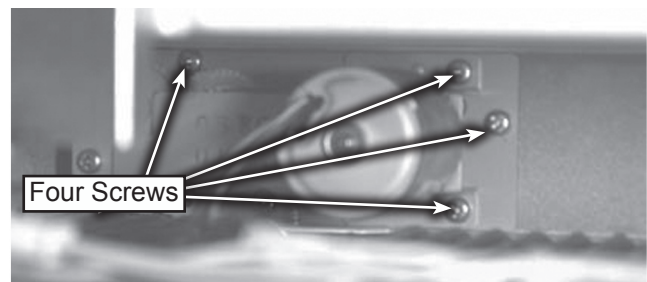

Figure 2

9. Disengage (pull) Auto Drawer Gear from rack gear and slide to the right (toward the rear), then turn motor 90° and slip out along rear of drawer, see figure 3.
10. Tilt Auto Gear Motor 20° to remove the assembly.

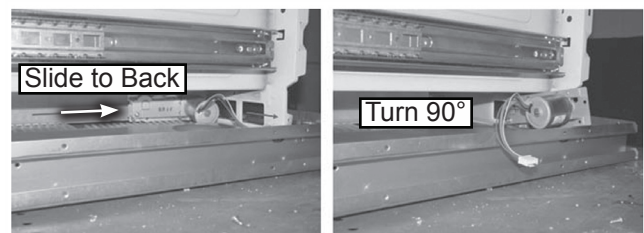

Figure 3

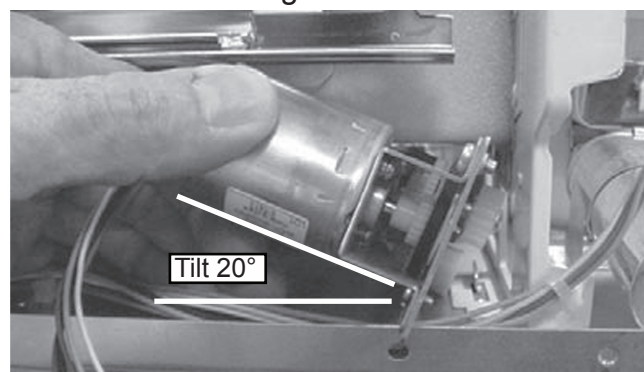

Figure 4

REMOVING THE RACK GEAR

⚠ WARNING



Electrical Shock Hazard
Disconnect power before servicing.
Replace all parts and panels before operating.
Failure to do so can result in death or electrical shock.

1. Unplug microwave drawer or disconnect power.
2. Discharge the high voltage capacitor terminals with a 20,000 Ω 2 watt resistor to chassis ground.
3. Follow the "Removing the Drawer Assembly on page 4-8.
4. Pull the center slide rail (rack gear) as far as it will go, see figure 1.



Figure 1

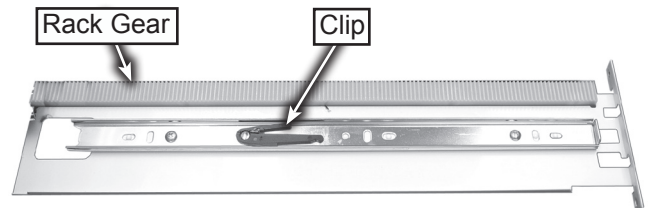

Top side of center slide rail
Figure 2

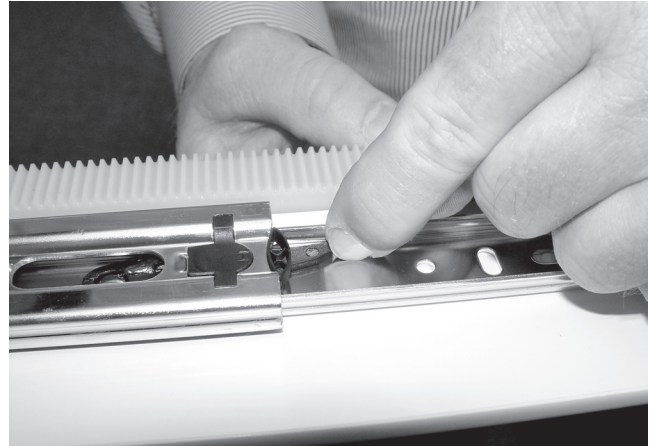
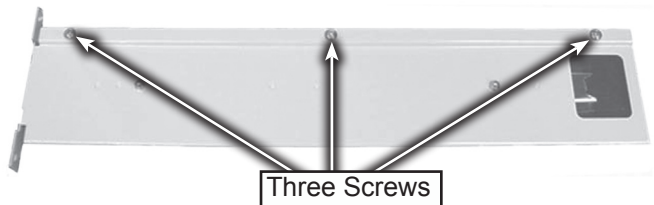

Figure 2A

5. Disengage the clip on the slide rail, see figure 2 and 2A.
6. Pull slide rail straight out to remove.
7. Remove the (3) screws holding the rack gear to the bottom slide rail, see figure 3.



Bottom side of center slide rail
Figure 3

— NOTES —

COMPONENT TESTING

⚠ WARNING



Electrical Shock Hazard
Disconnect power before servicing.
Replace all parts and panels before operating.
Failure to do so can result in death or electrical shock.

MICROWAVE OVEN POWER OUTPUT TEST

1. Place 8 oz (250 mL) of lukewarm water in the center of the microwave oven.
2. Operate on HIGH power level for 2 minutes. Water should be hot.

NOTE: If the water takes longer than 2 minutes to heat, this may indicate either the operating voltage is lower than 110 volts or there is a problem with the microwave oven.

Component Tests

IMPORTANT:

- Unplug microwave oven or disconnect power.
- Discharge the high-voltage capacitor and remove the lead wires from the primary winding of the high-voltage transformer before conducting any of the following tests.
- Remove the lead wires from the related component before conducting any of the following tests.
- Conduct a microwave energy test after performing any tests or repairs to the microwave oven.
- Check that all wire leads are in the correct positions before operating the microwave oven.
- All operational checks using microwave energy must be done with the microwave oven loaded with a minimum of 8 oz (250 mL) of water in a microwave safe container.
- Grasp wire connectors when removing the wire leads from microwave oven parts.
- All testing must be done with an ohmmeter having a sensitivity of 20,000 ohms per volt DC or greater, and powered by at least a 9-volt battery.

Components

Test/Results

H.V. Transformer

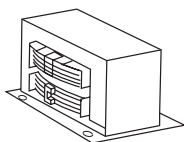

NOTE: The inside lead wire is red. The outside lead wire is white. Do not reverse leads.

1. Unplug microwave oven or disconnect power.
2. Remove wire leads.
3. Measure resistance:
 - Primary winding: 0.2 to 0.4 ohm (approximate)
 - Secondary winding: 60 to 90 ohms (approximate)
 - Filament winding: Less than 1 ohm
 - Primary winding to grounding: Normal: Infinite
 - Filament winding to grounding: Normal: Infinite

Magnetron

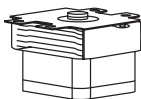

1. Unplug microwave oven or disconnect power.
2. Remove wire leads. Check that the seal is in good condition.
3. Measure resistance:
 - Filament terminal: Normal: Less than 1 ohm
 - Filament to chassis: Normal: Infinite

COMPONENT TESTING (continued)

Components

Test/Results

H.V. Capacitor

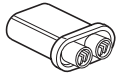

1. Unplug microwave oven or disconnect power.
2. Remove wire leads.
3. Prepare the DC 9-volt battery and 10k ohms resistance including wire leads.
4. Connect the DC 9-volt battery to the H.V. capacitor.
5. Measure resistance:
 - Terminal to terminal: Normal: 9 volts (approximate); Abnormal: 0 volts (approximate)
 - Terminal to case: Normal: 0 volts (approximate); Abnormal: 0 volts (approximate)

H.V. Diode

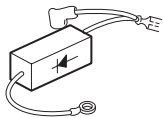

NOTE: Some inexpensive ohmmeters do not have a 9-volt battery incorporated in them, and may indicate infinite resistance in both directions when testing the diode. It is recommended that you use an ohmmeter with a 9-volt battery on the 10x scale to properly test the H.V. diode.

1. Unplug microwave oven or disconnect power.
2. For ohmmeters without a 9-volt battery, prepare the DC 9-volt battery and 10k ohms resistor in series including wire leads.
3. Connect the DC 9-volt battery to the H.V. diode.
4. Measure continuity:
 - Forward: Normal: 5 to 6 volts (approximate); Abnormal: Open—9 volts (approximate); Short—0 volts (approximate)
 - Reverse: Normal: 9 volts (approximate); Abnormal: Open—9 volts (approximate); Short—0 volts (approximate)

Stirrer Motor



1. Unplug microwave oven or disconnect power.
2. Remove wire leads.
3. Measure resistance:
 - Normal: $3.8k \pm 0.2k$ ohms (approximate)
 - Abnormal: Infinite

Cooling Fan Motor

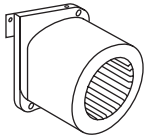

1. Unplug microwave oven or disconnect power.
2. Remove wire leads.
3. Measure resistance:
 - Normal:
 - A 95 to 120 ohms (approximate)
 - B 10 to 25 ohms (approximate)
 - Abnormal: Infinite

AC Line Filter

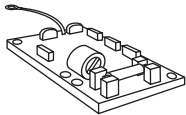

1. Unplug microwave oven or disconnect power.
2. Remove wire leads.
3. Measure resistance:
 - Normal: L(1) to L(2) (coil): Less than 1 ohm;
N(1) to N(2) (coil): Less than 1 ohm
 - Abnormal: Infinite
 - Normal: L(1) or L(2) to N(1) or N(2) (resistor): 1.5M ohms
 - Abnormal: 0 ohms

COMPONENT TESTING (continued)

Switching Power Supply (Switching Regulator)

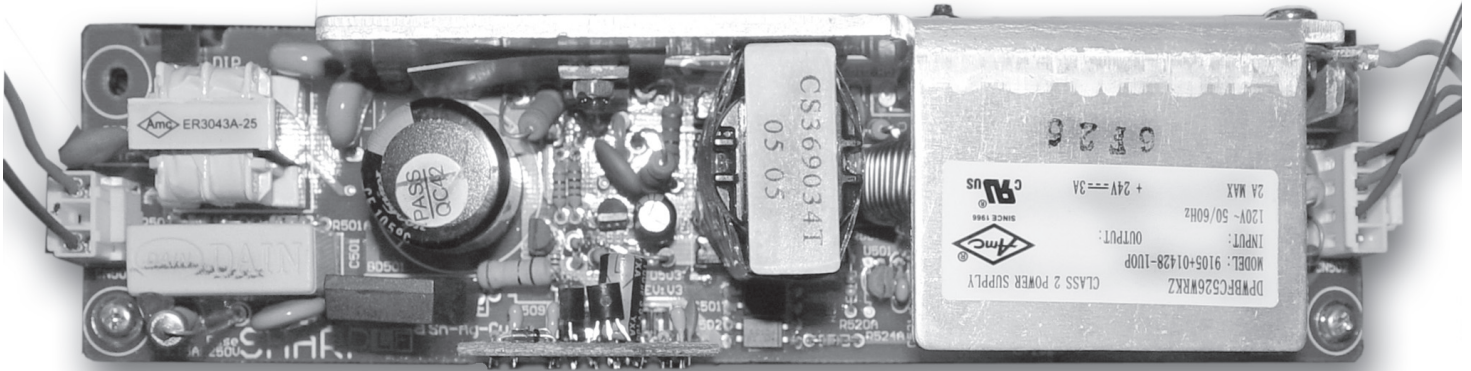

950W power output 120V

Switching power supply- "switching regulator" is a 24Vdc switching power supply (SW PSU). It is used to power the drawer motor to open/ close drawer. When Relay RY5 is active it allows the 24Vdc to get to the drawer motor. Relay RY5 is active only when the drawer is opening or closing.

DIAGNOSIS & TROUBLESHOOTING

TROUBLESHOOTING

⚠ WARNING



Electrical Shock Hazard

Disconnect power before servicing.

Replace all parts and panels before operating.

Failure to do so can result in death or electrical shock.

IMPORTANT: If the oven becomes inoperative because of a blown monitor fuse, check the monitor switch, relay RY1, secondary interlock relay RY2, secondary (door sensing) interlock switch, and primary interlock switch before replacing the monitor fuse. If monitor fuse is replaced, the monitor switch must also be replaced.

PRIMARY SECONDARY AND MONITOR INTERLOCK SWITCH CHECKOUT PROCEDURES

Switch	Check By	Drawer Open	Drawer Closed
Primary Interlock	<ol style="list-style-type: none"> 1. Unplug microwave oven or disconnect power. 2. Disconnect the wires at the Primary Interlock Switch. 3. Check the terminals. 	-	+
Secondary Interlock	<ol style="list-style-type: none"> 1. Unplug microwave oven or disconnect power. 2. Disconnect pin connector at the electronic control. 3. Check from the orange/black wire (pin 7) to the black/brown wire (pin 8). 	-	+
Monitor Interlock	<ol style="list-style-type: none"> 1. Unplug microwave oven or disconnect power. 2. Disconnect the common terminal (white/white wire) and the normally closed terminal (red/brown wire). 3. Check the terminals 	+	-

(+) Continuity (-) No Continuity

NOTE: These diagrams are not intended to show a complete circuit; they represent the position of switches during "DRAWER OPEN" or "DRAWER CLOSED" (continuity checks only).

Drawer Closed

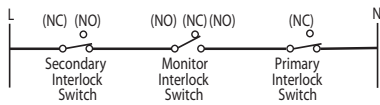

Drawer Open

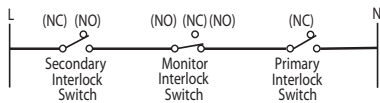

1. Unplug microwave oven or disconnect power.
2. A definite "click" can be heard when the microwave oven drawer is unlatched.
NOTE: Hold the drawer in a closed position and pull the drawer open. This causes the latch leads to rise, making it possible to hear the "click" as the drawer switches operate.
3. Visually check the drawer and cavity face plate for damage (dents, cracks, signs of arcing, etc.).
4. Carry out any remedial work that is necessary before operating the oven.

DIAGNOSTICS

Do not continue with the diagnostics of appliance if the household fuse is blown, a circuit breaker is tripped or if there is less than 120-volt power supply at the wall outlet.

Complete the following steps before checking microwave oven circuitry:

1. Unplug microwave oven or disconnect power.
2. Discharge high-voltage capacitor and disconnect white wire from power transformer.

3. Check for loose wiring or incorrect wiring within microwave oven.
4. All testing must be done with an ohmmeter having a sensitivity of 20,000 ohms per volt DC or greater, and powered by at least a 9-volt battery.
5. All operational checks using microwave energy must be done with the microwave oven loaded with a minimum of 8 oz (250 mL) of water in a microwave safe container.

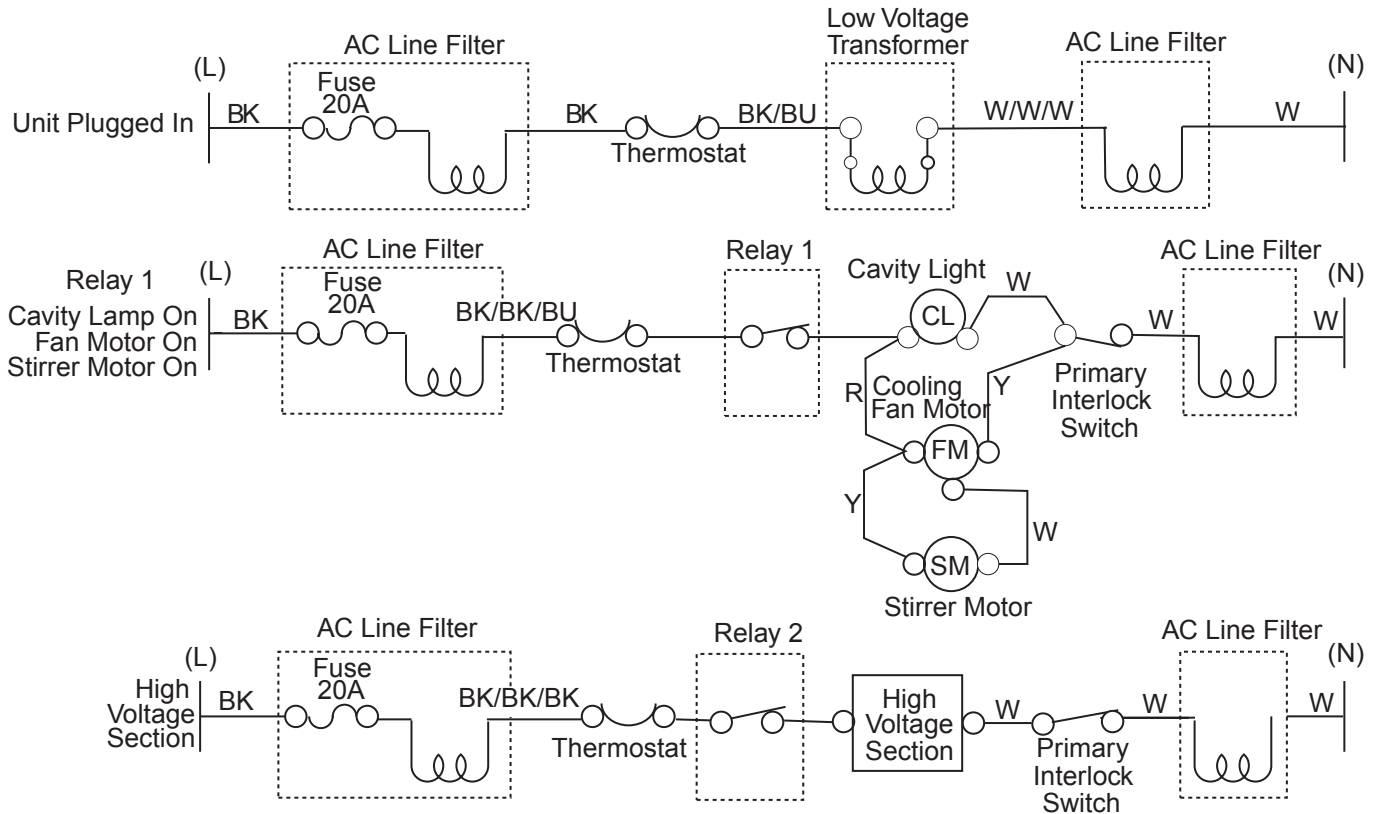

Touch Panel

Touch Panel Continuity Diagram

	J-4	J-3	J-2	J-1
J-12	-----	6	9	Timer Clock
J-11	-----	1	8	0
J-10	-----	2	3	5
J-9	-----	7	4	Power Level
J-8	-----	Sensor Cook	Open	-----
J-7	-----	Sensor Reheat	Sensor Popcorn	Setup Custom Help
J-6	Reheat	Defrost	Keep Warm	Control Lock On/Off
J-5	Stop/Clear	Start/Add 1 Minute	-----	Close

- NOTES -

WIRING DIAGRAM SCHEMATIC DIAGRAM

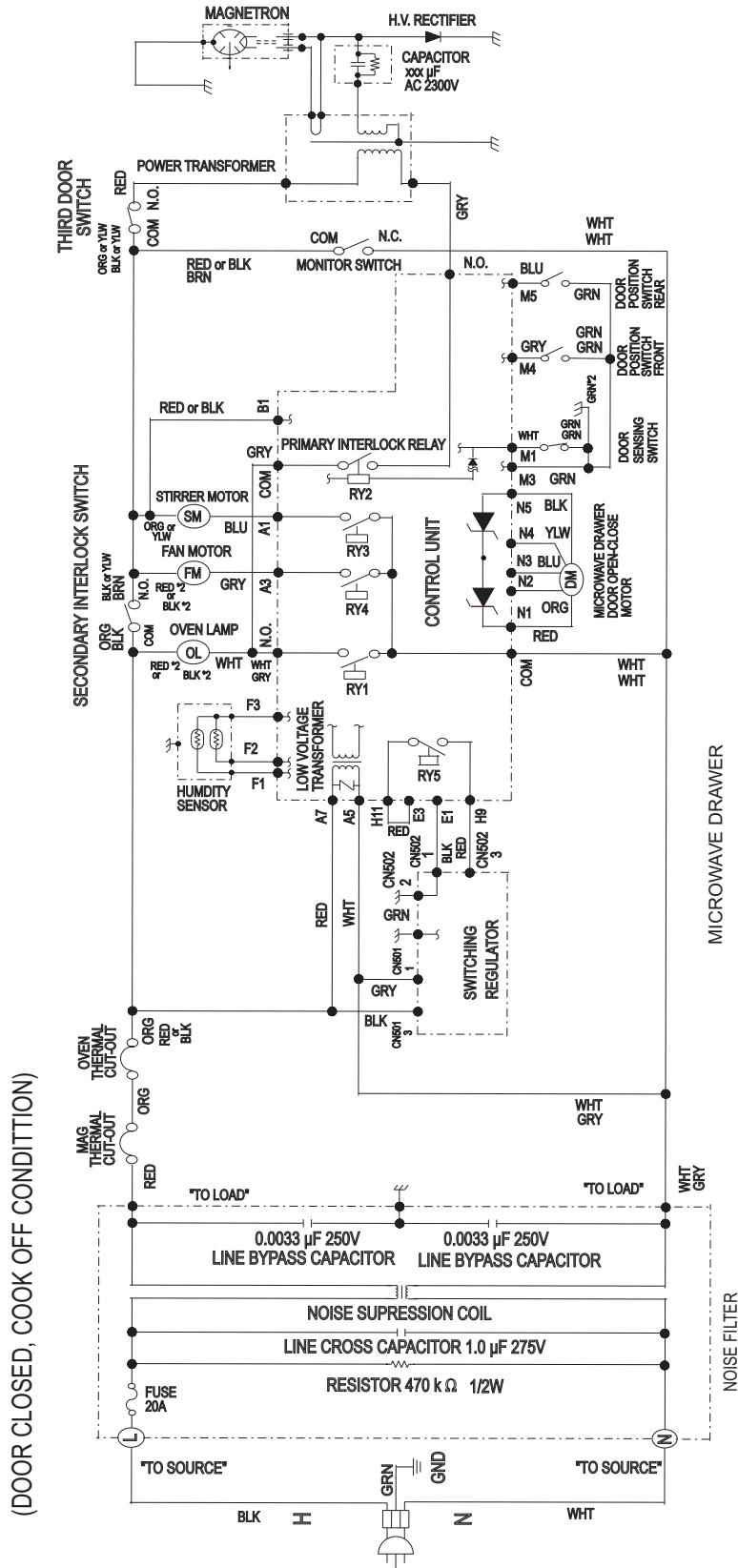

NOTES:

1. Circuits / Wire Colors subject to change without notice.
2. Terminal that is located on the right side on lamp socket's back view must be connected to neutral wire.
3. Only certain models use the absolute humidity sensor.
4. Power Transformer (Finish Lead) terminal must be connected to Hot wire (RED)

PRODUCT SPECIFICATIONS AND WARRANTY INFORMATION SOURCES

IN THE UNITED STATES:

FOR PRODUCT SPECIFICATIONS AND WARRANTY INFORMATION CALL:

FOR WHIRLPOOL PRODUCTS: 1-800-253-1301
FOR KITCHENAID PRODUCTS: 1-800-422-1230
FOR ROPER PRODUCTS: 1-800-447-6737

FOR TECHNICAL ASSISTANCE WHILE AT THE CUSTOMER'S HOME CALL:

THE TECHNICAL ASSISTANCE LINE: 1-800-253-2870

**HAVE YOUR STORE NUMBER READY TO IDENTIFY YOU AS AN
AUTHORIZED SERVICER**

FOR LITERATURE ORDERS:

PHONE: 1-800-851-4605

FOR TECHNICAL INFORMATION AND SERVICE POINTERS:

www.servicematters.com

IN CANADA:

FOR PRODUCT SPECIFICATIONS AND WARRANTY INFORMATION CALL:

1-800-461-5681

FOR TECHNICAL ASSISTANCE WHILE AT THE CUSTOMER'S HOME CALL:

THE TECHNICAL ASSISTANCE LINE: 1-800-488-4791

**HAVE YOUR STORE NUMBER READY TO IDENTIFY YOU AS AN
AUTHORIZED SERVICER**

