

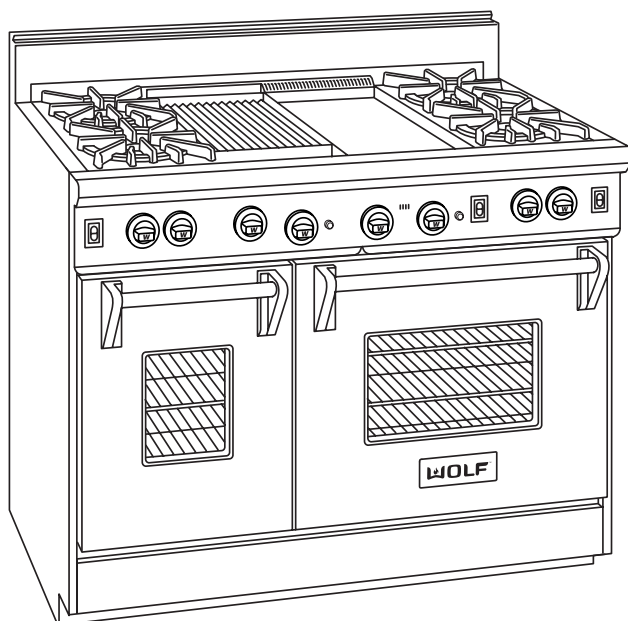

Technical Service Manual



Ranges

30 Inch

36 Inch

48 Inch

60 Inch

Rangetops

36 Inch

48 Inch

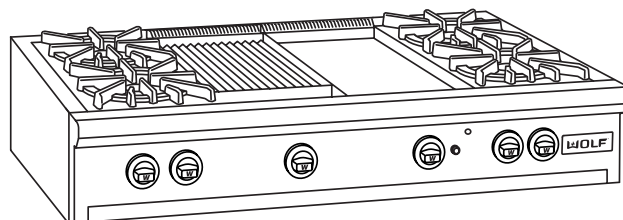

SECTION 1

GENERAL INFORMATION

INTRODUCTION

This Wolf Appliance Technical Service Manual, Part #803331, has been compiled to provide the most recent technical service information about the Wolf Appliance Company, LLC. Ranges and Rangetops. This information will enable the service technician to troubleshoot and diagnose malfunctions, perform necessary repairs, and return a Wolf Range and/or Rangetop to proper operational condition.

The service technician should read the complete instructions contained in this Training/Service Manual before initiating any repairs on a Wolf Appliance.

* *Some information in Section 2 (Theory of Operation) has been provided by the American Gas Association and reprinted with AGA's approval.*

IMPORTANT SAFETY INFORMATION

Below are the Product Safety Labels used in this manual. The "Signal Words" used are **WARNING** and **CAUTION**.

Please note that these safety labels are placed in areas where awareness of personal safety and product safety should be taken and lists the precautions to be taken when the signal word is observed.

⚠ WARNING

INDICATES THAT HAZARDOUS OR UNSAFE PRACTICES COULD RESULT IN SEVERE PERSONAL INJURY OR DEATH

⚠ CAUTION

Indicates that hazardous or unsafe practices could result in minor personal injury or product and/or property damage

In addition, please pay attention to the signal word "**NOTE**", which highlights especially important information within each section.

TECHNICAL ASSISTANCE

If you should have any questions regarding a Wolf appliance and/or this manual, please contact:

*Wolf Appliance Company, LLC
ATTN: Service Department
P.O. Box 44988
Madison, WI 53744-4988*

*Customer Service & Parts / Warranty Claims
Phone #: (800) 332 - 9513*

*Technical Assistance
Phone #: (800) 919 - 8324*

*Customer Service & Technical Assistance
Facsimile #: (608) 441 - 5887*

*Parts / Warranty Claims
Facsimile #: (608) 441 - 5886*

*Office Hours:
7:00 AM to 7:00 PM Central Time
Monday through Friday*

This manual is designed to be used by Authorized Service Personnel only. Wolf Appliance Company, LLC. assumes no responsibility for any repairs made to Wolf appliances by anyone other than Authorized Service Technicians.

The information and images are the copyright property of Wolf Appliance Company, LLC, an affiliate of Sub-Zero Freezer Company, Inc. Neither this manual nor any information or images contained herein may be copied or used in whole or in part without the express written permission of Wolf Appliance Company, LLC, an affiliate of Sub-Zero Freezer Company, Inc. © Wolf Appliance Company, LLC all rights reserved.

TABLE OF CONTENTS

	Page #		Page #
<u>Section 1 - General Information</u>		<u>Section 4 - Component Access and Removal Cont'd</u>	
Introduction.....	1-2	Switches & Lights.....	4-9
Important Safety Information.....	1-2	Thermostat.....	4-9
Technical Assistance.....	1-2	Components Below Roll Front.....	4-10
Table of Contents.....	1-3	Roll Front.....	4-10
Warranty Information.....	1-5	Surface Burner Valve.....	4-10
Model Features.....	1-6	Charbroiler/French Top Valve.....	4-10
Model Key.....	1-7	Components Behind Lower Access Panel.....	4-11
Top Configurations - 30", 36" & 48" Ranges.....	1-8	Lower Access Panel.....	4-11
Top Configurations - 60" Range.....	1-9	Door Switch.....	4-11
Top Configurations - Rangetops.....	1-10	Oven Burner Bi-Metal Valve.....	4-11
<u>Section 2 -Theory of Operation</u>		Oven Burner Orifice.....	4-11
Types of Fuel Gas.....	2-2	Oven Compartment Components.....	4-12
Heating Value of Gas.....	2-2	Oven Rack.....	4-12
Specific Gravity of Gas.....	2-2	Oven Rack Guide.....	4-12
Principals of Gas Combustion.....	2-3	Oven Light Components.....	4-12
Burner Components.....	2-4	Oven Convection Fan.....	4-12
Types of Burners.....	2-5	Oven Bottom Panel.....	4-12
Simple Theory of Operation.....	2-6	Oven Flame Deflector.....	4-13
<u>Section 3 - Installation Information</u>		Oven Burner Tube.....	4-13
Gas Pressure.....	3-2	Oven Glow Coil Igniter.....	4-13
Leak Testing.....	3-2	Oven Broiler Glow Coil Igniter.....	4-14
Electrical Requirements.....	3-2	Oven Infrared Broiler Burner.....	4-14
Unit Blocking.....	3-3	Oven Door Components.....	4-15
Unit Leveling.....	3-3	Door Assembly.....	4-15
Range Installation Dimensions.....	3-4	Disassembling Door.....	4-15
Rangetop Installation Dimensions.....	3-5	Side Panels & Components on Rear of Unit.....	4-16
<u>Section 4 - Component Access and Removal</u>		Side Panels.....	4-16
Important Warnings & Cautions.....	4-2	Oven Bi-Metal Valve.....	4-16
Surface Burner Components.....	4-3	Oven Broiler Orifice.....	4-16
Burner Grate & Rings.....	4-3	Spark Module.....	4-16
Pressed Steel Top.....	4-3	Fan Relay.....	4-16
Surface Burner Body.....	4-3	<u>Section 5 -Troubleshooting Guide</u>	
Surface Burner Orifice.....	4-4	How to Use the Troubleshooting Guide.....	5-2
Surface Burner Electrode.....	4-4	Troubleshooting Guide Table of Contents.....	5-2
Surface Burner Support.....	4-4	Troubleshooting Guide.....	5-3
Infrared Charbroiler Components.....	4-5	<u>Section 6- Technical Data</u>	
Cover, Grate & Frame.....	4-5	Gas Pressure Table.....	6-2
Charbroiler Orifice.....	4-5	Orifice Chart.....	6-2
Charbroiler Burner Box.....	4-5	Checking Oven Ignition System.....	6-3
Charbroiler Sparker.....	4-5	<u>Section 7 - Wiring Diagrams</u>	
Infrared Griddle Components.....	4-6	RANGES	
Griddle Plate.....	4-6	Model R304.....	7-2
Griddle Orifice.....	4-6	Model R366.....	7-3
Griddle Burner Box.....	4-6	Model R364C.....	7-4
Griddle Solenoid Valve.....	4-7	Model R364C.....	7-5
Griddle Thermostat.....	4-7	Model R488.....	7-6
Griddle Sparker.....	4-7	Model R486C.....	7-7
French Top Components.....	4-8	Model R486G.....	7-8
Rings, Plate, Spacers & Burner Head.....	4-8	Model R484CG.....	7-9
French Top Burner Pan.....	4-8	Model R484DC.....	7-10
French Top Electrode & Electrode Wire.....	4-8	Model R484DG.....	7-11
French Top Orifice.....	4-8	Model R484F.....	7-12
Control Panel Components.....	4-9	Model R482CF.....	7-13
Control Panel.....	4-9		

Page #

Section 7 - Wiring Diagrams Cont'd

<i>Model R606DC.....</i>	<i>7-14</i>
<i>Model R606DG.....</i>	<i>7-15</i>
<i>Model R606F.....</i>	<i>7-16</i>
<i>Model R606CG.....</i>	<i>7-17</i>
<i>Model R604CF.....</i>	<i>7-18</i>
<i>Model R604GF.....</i>	<i>7-19</i>

RANGETOPS

<i>Model RT366.....</i>	<i>7-20</i>
<i>Model RT364C.....</i>	<i>7-21</i>
<i>Model RT364G.....</i>	<i>7-22</i>
<i>Model RT362F.....</i>	<i>7-23</i>
<i>Model RT488.....</i>	<i>7-24</i>
<i>Model RT486C.....</i>	<i>7-25</i>
<i>Model RT486G.....</i>	<i>7-26</i>
<i>Model RT484CG.....</i>	<i>7-27</i>
<i>Model RT484DC.....</i>	<i>7-28</i>
<i>Model RT484DG.....</i>	<i>7-29</i>
<i>Model RT484F.....</i>	<i>7-30</i>
<i>Model RT484F.....</i>	<i>7-31</i>

WARRANTY INFORMATION

This page contains a summary of the 2 & 5 Year *Warranty* that is supplied with every Wolf product, followed by details and notes about the warranties.

TWO & FIVE YEAR Warranty Summary

- Two year TOTAL PRODUCT warranty, parts and labor.
- Limited Parts Only Warranty for the 3rd through 5th year on the following parts only:
Gas Burners (*excluding appearance*)
- Stainless Steel (Classic, Platinum & Carbon) doors, panels and product frames are covered by a limited 60 day parts and labor warranty for cosmetic defects.

Warranty Details:

The warranty applies only to products installed for normal residential use. The warranty applies only to products installed in the United States or Canada.

Warranty Notes:

- All warranties begin at the time of the unit's initial installation.
- All Warranty and Service information collected by Wolf Appliance Company, LLC. is arranged and stored under the unit serial number and/or the customer's name. Please note that Wolf Appliance LLC. requests that you have the model and serial number available whenever contacting the factory or parts distributor.
- See Figure 1-1 for typical serial plate layout.
- See Figures 1-2, 1-3 for serial plate location and access.

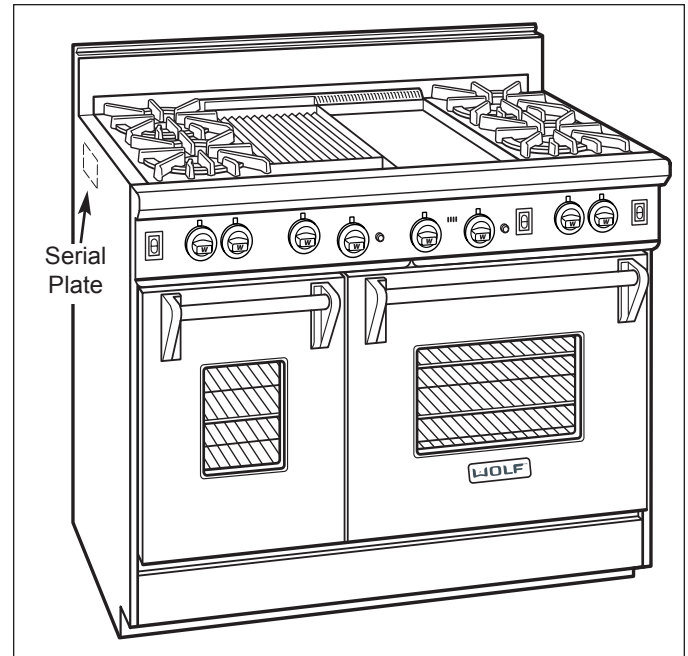

Figure 1-2. In most cases the serial plate is located inside the top burner box, on the left inside panel of ranges and rangetops. But, on models with the French Top located on the left, the serial plate is on the opposite (right) side.

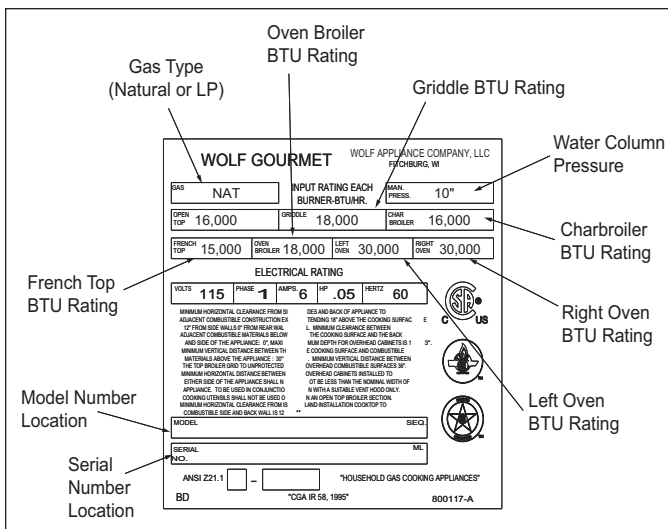

Figure 1-1. Typical Serial Plate Layout

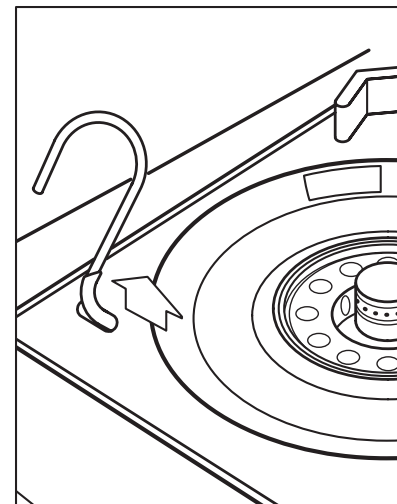

Figure 1-3. To access the serial plate, remove the grates from the pressed steel top. Remove the burner heads and then use the "S" hook supplied with the unit to remove the pressed steel top.

MODEL FEATURES

All ranges:

Oven burners input rated at 18,000 and 30,000 BTU. Infrared Oven Broiler input rated at 18,000 BTU.

Some models:

Charbroiler on rangetop rated at 16,000 BTU input. Griddle on rangetop rated at 18,000 BTU input. French Top on rangetop rated at 15,000 BTU input.

RANGE FEATURES:

- Natural or LP gas models
- Classic stainless steel exterior
- Large red control knobs with four position settings (optional blackknobs available)
- Chrome bezels surround all knobs
- Dual brass burners with automatic re-ignition at all settings
- Cast iron porcelain coated grates
- Optional S-grates available
- Stainless steel drip tray on ball bearing slides
- Door windows and interior lights in ovens
- Porcelain oven interior
- 3" (76 mm) adjustable stainless steel legs in front and adjustable rear casters
- Full side panels and skirt
- High altitude conversion kit available
- Optional risers – 5" (127 mm), 10" (254 mm) and 20" (508 mm) with shelf
- Two and five year residential warranty
- CSA certified for US and Canada

RANGETOP FEATURES:

- Natural or LP gas models
- Classic stainless steel exterior
- Large red control knobs with four position settings (optional black knobs available)
- Chrome bezels surround all knobs
- Dual brass burners with automatic re-ignition at all settings
- Cast iron porcelain coated grates
- Optional S-grates available
- Stainless steel drip tray on ball bearing slides
- Low profile stainless steel island trim
- High altitude conversion kit available
- Optional 10-1/2" (267 mm) riser
- Two and five year residential warranty
- CSA certified for US and Canada

MODEL NUMBER KEY

Refer to this key for an example of the model numbers.

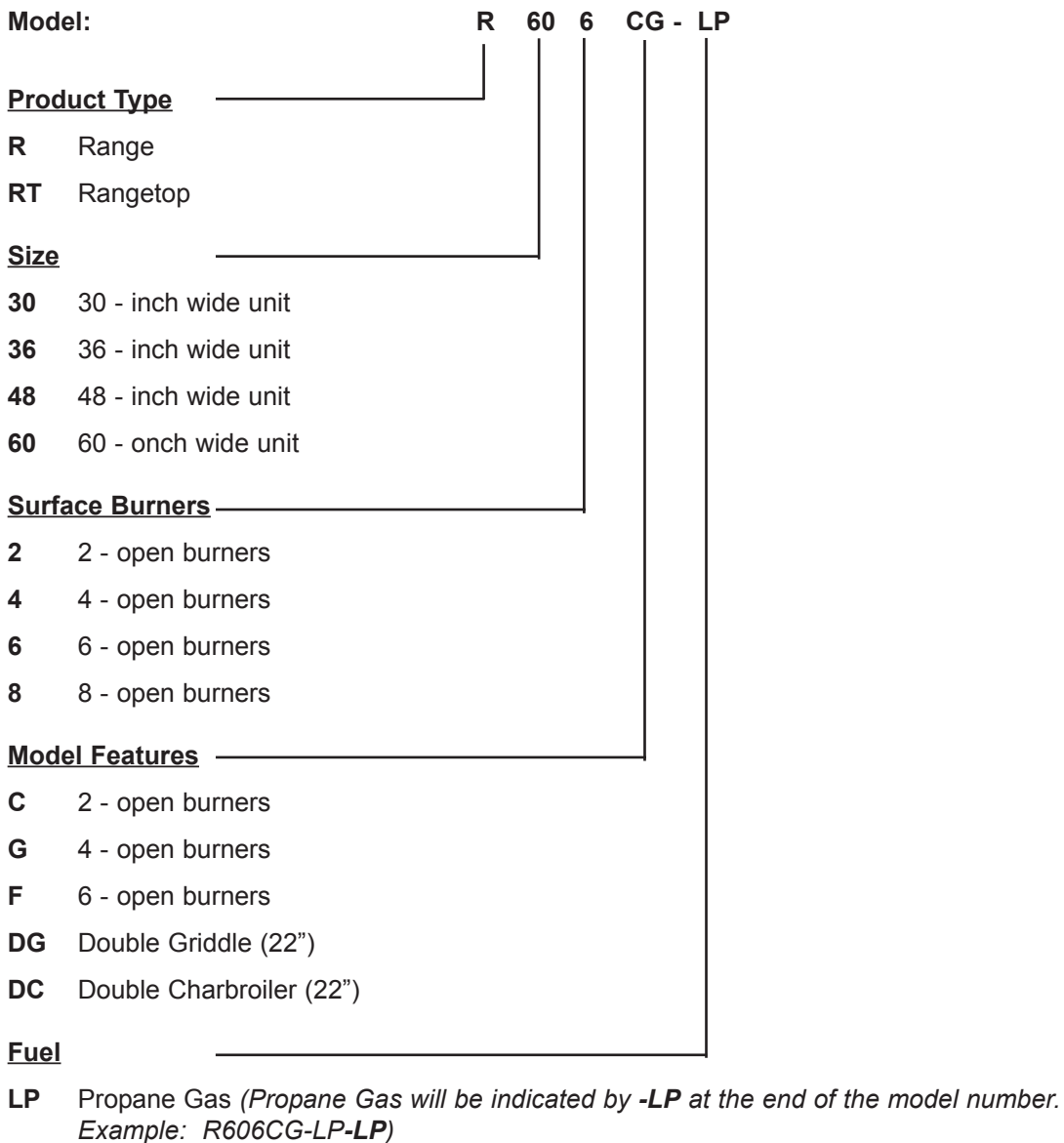

NOTE: If model number doesn't have -LP at the end, unit is Natural Gas.

TOP CONFIGURATIONS OF 30", 36" and 48" RANGES

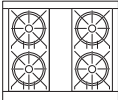
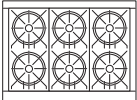
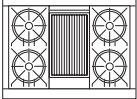
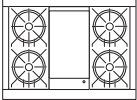
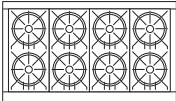
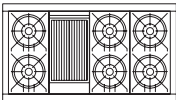
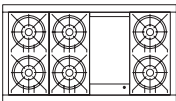
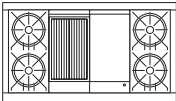
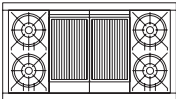
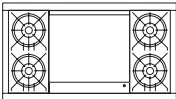
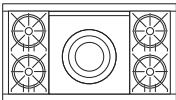
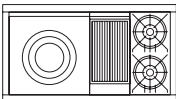
Configuration	New Model #	Old Model #	Description
	R304	AS30Ki	4 Open Burners
	R366	AS36Ki-2	6 Open Burners
	R364C	AS36Ki-7	4 Open Burners - w/11" Charbroiler
	R364G	AS36Ki-6	4 Open Burners - w/11" Griddle
	R488	PS488K	8 Open Burners
	R486C	PS486BK	6 Open Burners - w/11" Charbroiler
	R486G	PS486GK	6 Open Burners - w/11" Griddle
	R484CG	PS48GBK	4 Open Burners - w/11" Charbroiler & 11" Griddle
	R484DC	PS484BK	4 Open Burners - w/22" Charbroiler
	R484DG	PS484GK	4 Open Burners - w/22" Griddle
	R484F	PS484FK	4 Open Burners - w/22" French Top
	R482CF	PS48FBK	2 Open Burners - w/11" Charbroiler & 22" French Top

NOTE: (- LP) Following the New Model Number signifies Propane Gas

TOP CONFIGURATIONS OF 60" RANGE

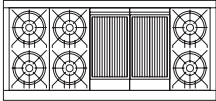
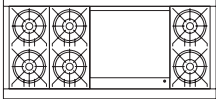
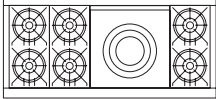
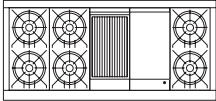
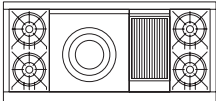
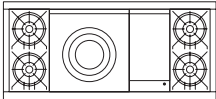
Configuration	New Model #	Old Model #	Description
	R606DC	S60BKK	6 Open Burners - w/22" Charbroiler
	R606DG	S60GKK	6 Open Burners - w/22" Griddle
	R606F	S60FKK	6 Open Burners - w/22" French Top
	R606CG	S60GBKK	6 Open Burners - w/11" Charbroiler & 11" Griddle
	R604CF	S60FBKK	4 Open Burners - w/11" Charbroiler & 22" French Top
	R604GF	S60FGKK	4 Open Burners - w/11" Griddle & 22" French Top

NOTE: (- LP) Following the New Model Number signifies Propane Gas

TOP CONFIGURATIONS OF 36" & 48" RANGETOPS

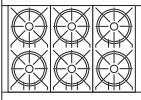
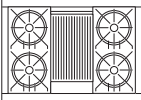
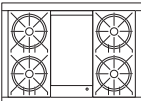
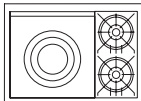
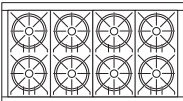
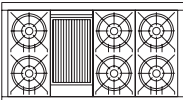
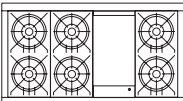
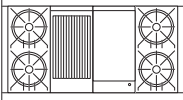
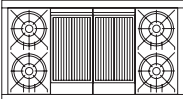
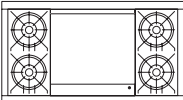
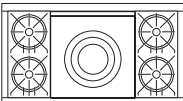
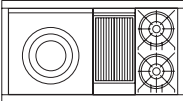
Configuration	New Model #	Old Model #	Description
	RT366	SB366	6 Open Burners
	RT364C	SB364B	4 Open Burners - w/11" Charbroiler
	RT364G	SB364G	4 Open Burners - w/11" Griddle
	RT362F	SB362F	2 Open Burners - w/22" French Top
	RT488	SB488	8 Open Burners
	RT486C	SB486B	6 Open Burners - w/11" Charbroiler
	RT486G	SB486G	6 Open Burners - w/11" Griddle
	RT484CG	SB48GB	4 Open Burners - w/11" Charbroiler & 11"Griddle
	RT484DC	SB484B	4 Open Burners - w/22" Charbroiler
	RT484DG	SB484G	4 Open Burners - w/22" Griddle
	RT484F	SB484F	4 Open Burners - w/22" French Top
	RT482CF	SB48FB	2 Open Burners - w/11" Charbroiler & 22" French Top

NOTE: (- LP) Following the New Model Number signifies Propane Gas

SECTION 2

THEORY OF OPERATION

THEORY OF OPERATION

A service technician should understand how a gas appliance operates before attempting to service the appliance. This section provides descriptions of the different types of fuel gases and explains gas heating values. A definition of specific gravity of gas is given along with its characteristics and effects. Gas combustion principals are explained and gas burner components are described and illustrated. The end of this section contains illustrations which demonstrate basic cooking appliance theory of operation.

Types of Fuel Gas:

Gases used to supply heat energy are called fuel gases. Common fuel gases are not simply one kind of hydrocarbon, they are mixtures of hydrocarbon gases. They contain other gases as well, such as free hydrogen, carbon dioxide and nitrogen. As an example natural gas might contain 85% methane, 12% ethane and 3% of other gases. The presence of each of these gases in the fuel gas has some effect on the nature of the gas.

Some common fuel gasses are methane [CH₄], ethane [C₂H₆], Propane [C₃H₈] and butane [C₄H₁₀]. Propane and butane are nearly odorless. Natural gas that is processed to remove condensables and moisture, has little or no odor and no color. Odorants are added to natural gas before distribution to aid in leak detection. A common odorant used is a colorless liquid containing sulfur compounds.

Heating Value of Gas:

Heat energy produced when burning a fuel gas is commonly expressed in British Thermal Units (BTU). One BTU of heat will raise the temperature of one pound of water one degree Fahrenheit.

The more carbon and hydrogen atoms in each molecule of a fuel gas, the higher its heating value. Natural gas which is high in methane has a heating value of about 950 to 1150 BTU per cubic foot. The variance is due to the various other substances found in natural gases. The more ethane, propane or butane in the gas raises the heating value. Propane, or LP gas, has a heating value of about 2500 BTU per cubic foot, and butane about 3200 BTU per cubic foot.

Specific Gravity of Gas:

The specific gravity of a gas is the weight of one cubic foot, or the gas compared to one cubic foot of dry air. When stating the specific gravity of a gas, a pressure and temperature must be clearly stated. In the gas industry, the standard conditions of pressure and temperature are 30.0 inches of mercury and 60° F. A pressure of 30.0 inches of mercury will sustain a column of mercury 30 inches high in a tube with a vacuum on top of the column. Since air is used as the reference, its specific gravity is always 1.0. This value of 1.0 has no direct physical meaning with regard to air, such as its density. It is only a relative number or ratio used to express specific gravity of other gases.

The specific gravity of a gas will determine if the gas will rise or fall when released into the air. Natural gas will rise since its specific gravity is less than 1.0 at 0.4 to 0.8. Propane has a specific gravity of 1.5 and butane 2.0. These gases will fall when released into the air. They sometimes collect in low spots into pools which become a hazard if open flames are present.

In addition, specific gravity has two other characteristics. It has an important effect on the flow of gases through orifices, and hence the rating of the burners. Gas flow through an orifice is dependent upon the orifice size and the gas pressure upstream of the orifice. More of a lighter gas will flow through a given orifice size than a heavier gas at the same gas pressure. This effect is taken into account in tables and calculators used to select orifice sizes for burners.

The gas flow in pipes is also affected by specific gravity. At a given pressure at a pipe inlet, more lighter gas will flow through a pipe than a heavier gas.

Principals of Gas Combustion:

Combustion - When oxygen acts with a substance to produce large amounts of heat rapidly.

Requirements for Combustion - There are three required elements for combustion to occur; Fuel (Gas), Oxygen (Air) and Heat (Ignition Temperature, which for gas is between 1100°F/593°C and 1200°F/649°C). All must be present. Removing any one of the three and combustion will cease.

Chemistry of Combustion - Combustion of gas is a chemical reaction between fuel gas and oxygen. The basic elements of common fuel gasses are hydrogen [H] and carbon [C]. When hydrogen burns, water vapor [H₂O] is produced. Complete burning of carbon in fuel gases form carbon dioxide [CO₂] and water vapor [H₂O].

Controlled Combustion - Controlled combustion takes place when gas and air are supplied at proper rates to assure complete combustion of the gas in a steady flame. When a gas appliance is operating properly, burning starts at the burner ports. Gas flow is controlled by gas orifice size and gas pressure upstream of the orifice. Air is mixed with the gas before it passes through the burner ports. This added air is called "Primary Air". The remaining air required for complete combustion is supplied to the burner at the point of combustion and is called "Secondary air".

Adjustments of the gas-to-air ratio and the secondary air supply is the key to obtaining stable blue flames at a burner. Proper amounts of primary and secondary air are required for quiet and efficient burner operation and for complete combustion of the gas. Air Shutters or other devices provide control of primary air. Inlet opening and flue outlets control Secondary Air flow.

Total air - In an ideal situation, primary and secondary air is all that is needed (for the oxygen required) to burn the gas, but some additional air is required to assure complete burning of the gas. The total air, "primary", "secondary" and "excess" are expressed as percentages of the amount needed. About ten cubic feet of air is required to completely burn one cubic foot of gas. For this reason an appliance should not be operated in an air tight home.

Limits of Flammability - Not all air-to-gas mixtures will burn. Mixtures with 0% - 4% natural gas in air are too lean to burn. Mixtures of 4% - 14% natural gas in air can burn with a controlled flame. Flammability limits come into play when primary air adjustments are made on burners. If too much primary air is used, the mixture may become too lean and fall below flammability limits, thus preventing combustion.

Incomplete Combustion (Causes and Effects) - To obtain complete combustion, sufficient amounts of air must be supplied to the process. This air must have a reasonably normal oxygen content. Complete burning of gas produces harmless carbon dioxide gas and water vapor. If the air supply is insufficient, incomplete combustion occurs resulting in the formation of toxic byproducts, such as carbon monoxide [CO] or aldehydes.

Carbon monoxide is colorless and odorless. Inhaling carbon monoxide in sufficient quantities could cause death by reducing oxygen levels in the blood.

Aldehydes, which are equally dangerous, have a sharp and penetrating odor which is easily detected by smell at very low concentrations. The odor caused by aldehydes should not be confused with odorants added to natural gas. The absence of aldehydes does not assure that carbon monoxide is not present. However, if the odor of aldehydes is present, then carbon monoxide is virtually always present.

Gas Burner Operation - A gas burner is a device to burn gas under control in order to produce useful heat.

Primary air is brought into the burner from outside of the appliance at atmospheric pressure. The gas jet streaming from the orifice draws primary air with it into the burner.

The gas/air mixture, combined with a spark at the burner port(s) and the secondary air creates a controlled burn.

Burner Components:

Gas Orifice - An opening or hole which regulates or limits the amount of gas flowing to a burner. Gas flow rate (volume) depends on the size of the orifice (hole) and the gas pressure at the inlet of the orifice.

Air Shutter - This is used to adjust the size of the primary air inlet area and therefore controls primary air flow.

Venturi Tube (*Open Surface Burner & French Top Only*) - A section of pipe at the inlet of the burner body that narrows and then flares out again. This tube helps maintain a proper and constant primary air injection.

Mixing Tube/Throat - Serves to carry the gas/air mixture from the venturi tube to the burner body.

Burner Body - The accumulation chamber below the burner base which allows the gas and air to mix together fully.

Burner Base/Cross Over Ring - The component below the burner ring which carries the gas/air mixture to the burner ring.

Burner Ring/Burner Head - The component containing the burner ports where the gas/air mixture ignites. The burner ports are distributed in a useful pattern to optimize heat transfer. The flames should be spread so they can be easily reached by secondary air and provide a stable blue flame.

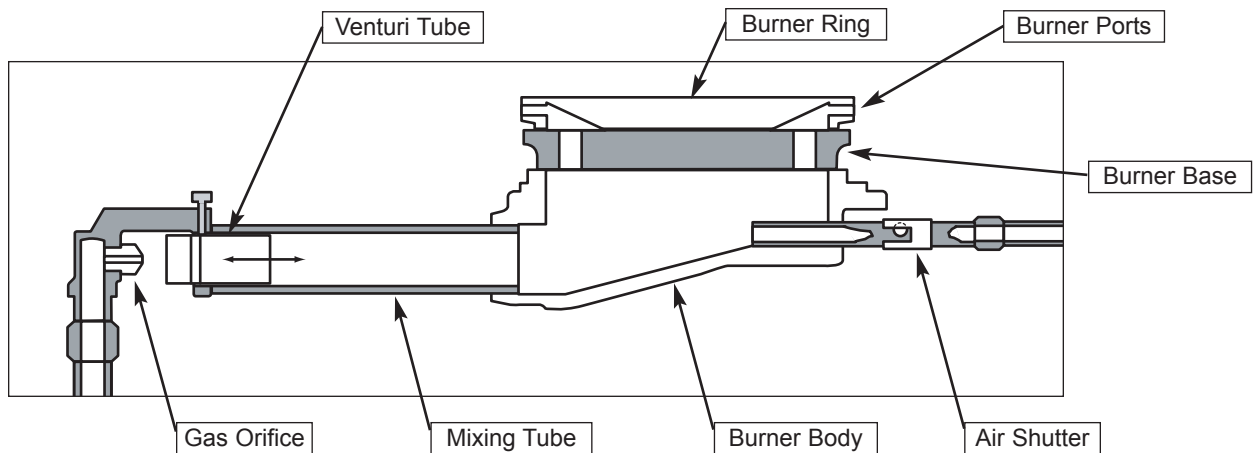

Figure 2-1. Cut-away View of Open Surface Burner Components

Types of Burners:

Blue Flame Burners - All Wolf open surface burners, French Top burners and the "U" burner in the oven are blue flame burners. With this type of burner, primary air is mixed with the fuel gas before the gas reaches the burner ports. An orifice is used to regulate gas flow to the burner. Air which is mixed with the gas inside the burner body enters through openings in the burner body. A shutter or venturi tube is used to adjust the size of these openings and control the primary air. Gas and air mix in the mixing tube or throat, which then exits the burner ports where it is ignited. Secondary air is air from around the flames. The flame produced has several zones, each represents a stage in burning of the gas. The burner tip has a thin dark blue cone called the inner or primary cone. A lighter cone called the outer cone, surrounds the inner cone. Air around the flame diffuses into the flame to burn at the outer cone. If conditions are perfect, products from the inner cone burn here. The final products of burning are carbon dioxide and water vapor. An outer mantle surrounds the outer cone where burning is usually completed. It is nearly invisible and glows only because of the high temperature of the final combustion.

Infrared Burners - Wolf gas ranges also use two types of infrared burners. The under-fired application for the charbroiler and the griddle uses a porous refractory ceramic tile burner. (See Figure 2-2) An over-fired screen type burner is used in the oven broiler. With these two types of burners, a substantial amount of energy output is in the form of infrared radiant energy. With infrared heat, thermal energy is transmitted through space without heating the medium through which it travels. Infrared energy is usually not affected by air flowing between the burners and heated surfaces because of the burner's numerous and tiny flames. This type of heat is very efficient and compact. The under-fired refractory infrared burner requires 100 percent primary air and is designed to have a hot glowing burner surface. The flame burns close to the burner surface at a high temperature. In the case of the over-fired screen type oven broiler, it does not require 100 percent primary air since sufficient amounts of secondary air can easily reach the screen where the gas is burning.

NOTE: *There is no shutter on infrared burners for adjusting the primary air and there is no change in orifice size for different altitude.*

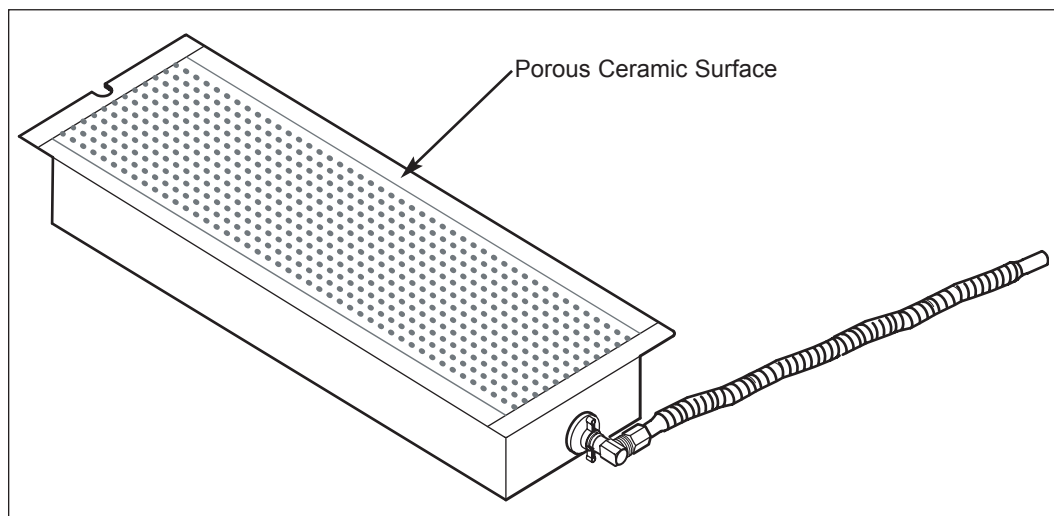

Figure 2-2. Infrared Burner (Under-fired Application for the Charbroiler or Griddle Shown)

Gas Cooking Appliance Simple Theory of Operation:

Gas arrives at the house through pipes (usually under ground) in the form of natural gas or liquid propane gas. This gas supply can be from a local utility source or a tank source.

A "Gas Pressure Regulator" on the appliance is connected to the gas supply line of the house. The regulator maintains the gas pressure in the appliance at a given point below the house gas pressure. (See Figure 2-3)

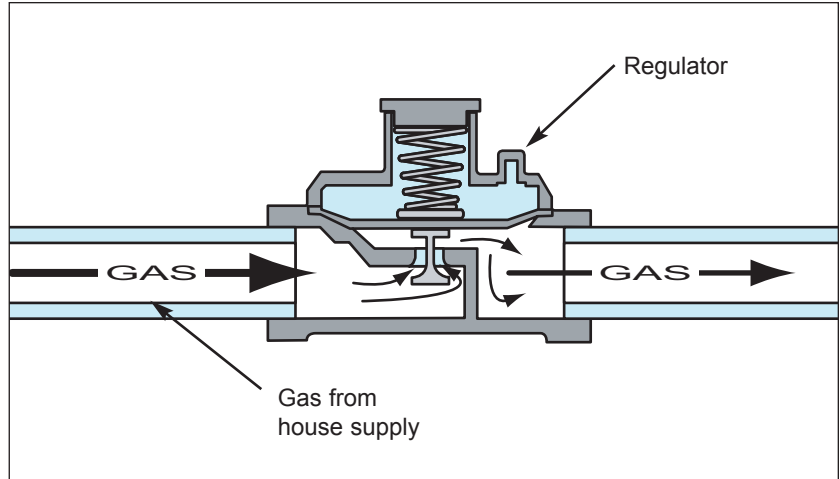

Figure 2-3. Gas Pressure Regulator

The gas passes through the regulator and is piped to a valve. This valve can be opened in varying amounts, to allow a specific quantity of gas to pass through. This is how the size of the flame is adjusted. (See Figure 2-4)

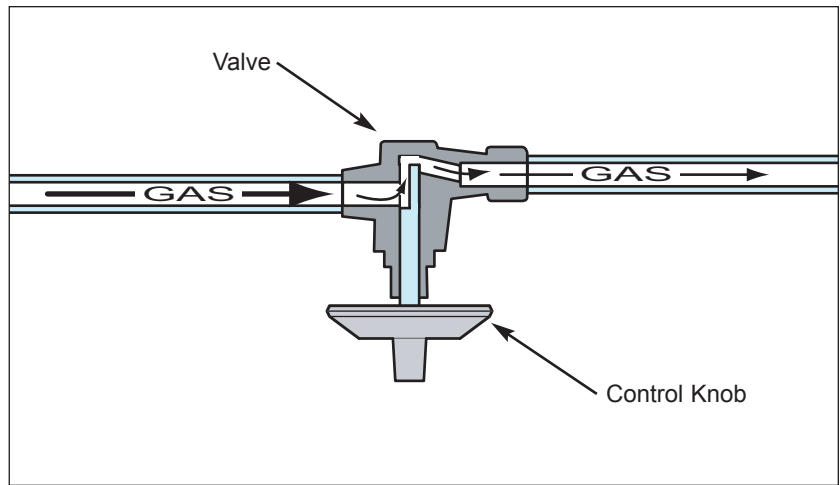

Figure 2-4. Gas Valve

After the valve, the gas is piped to a "gas orifice," which is an opening of very small diameter. The gas is pushed through the small diameter of the gas orifice, so when it exits it is under high velocity. This high velocity stream of gas causes a drop in pressure around itself. The low pressure around the stream of gas draws the nearby air, referred to as "primary air," with it into the venturi tube. (See Figure 2-5)

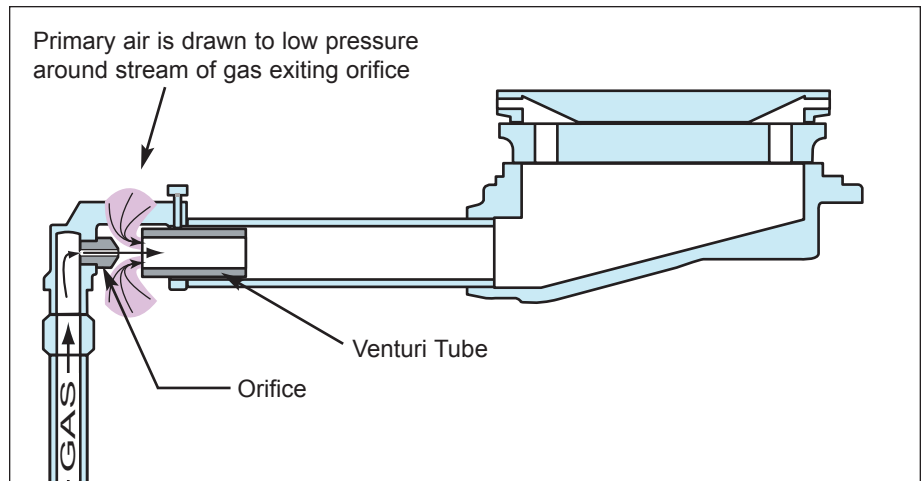

Figure 2-5. Gas Orifice

(Continued on next page)

The gas and air travel through the venturi tube and the mixing tube, also called the throat, where the gas and air begin to mix together. The gas and air mixture then enters into the base of the burner. The large volume of the base allows the gas and air to expand, mixing them together thoroughly. (See Figure 2-6)

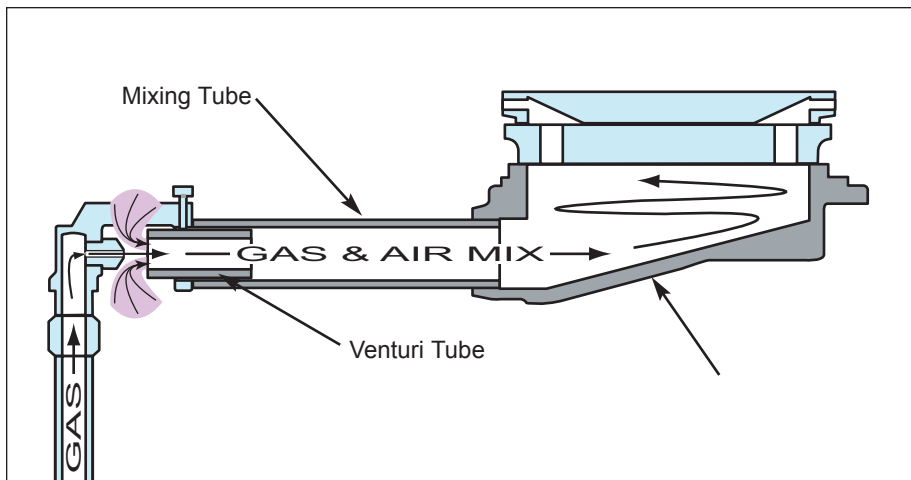

Figure 2-6. Venturi, Mixing Tube & Burner Body

The gas and air mixture then exits out of the burner ports where it further mixes with "secondary air." A spark is introduced to this gas and air mixture as it leaves the burner ports, which causes ignition. (See Figure 2-7)

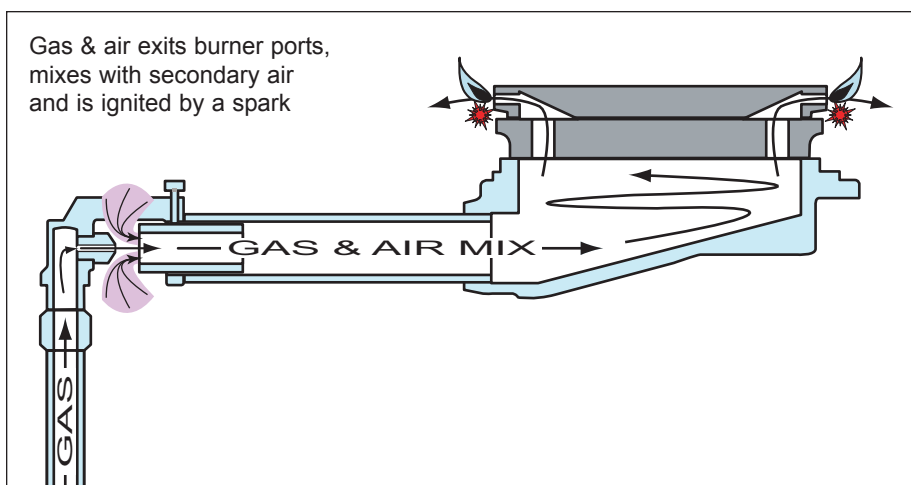

Figure 2-7. Gas/Air Exit Burner Ports and is Ignited

With the proper gas and air mixture, a flame of natural gas should be blue with a deep blue inner cone and have no trace of yellow flame. (See Figure 2-8)

With liquid propane gas some orange tipping is acceptable. In both cases, the flame should be odorless and completely free of dangerous gases.

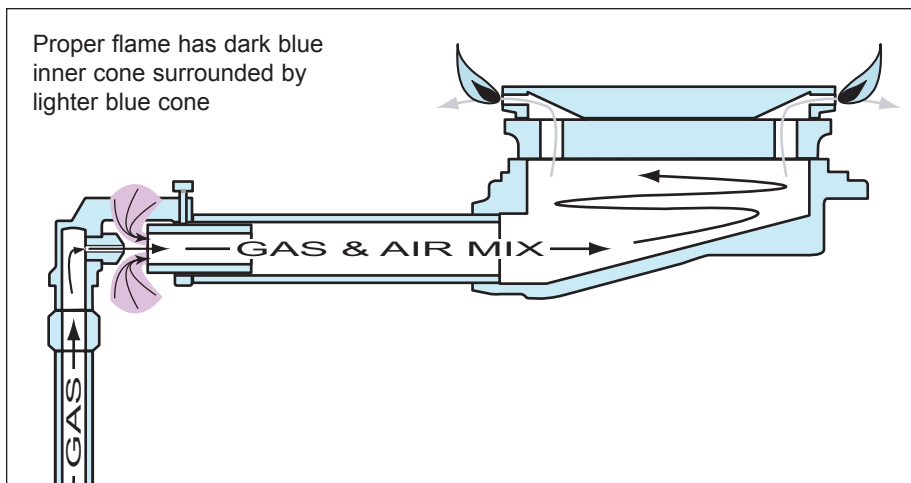

Figure 2-8. Proper Flame

SECTION 3

INSTALLATION INFORMATION

INSTALLATION INFORMATION

This section of the manual covers some of the installation issues that a service technician may need to know when servicing a Wolf range or rangetop. If additional installation information is needed after reviewing this section of the manual, please refer to the installation guide or contact the Wolf Appliance Customer Service Department.

Gas Pressure:

NOTE: All Wolf gas appliances are manufactured to work with natural gas, but Wolf gas appliances can be converted to work with LP gas (Liquid Propane gas).

Natural Gas Manifold Pressure

Standard natural gas orifices on the appliance are set for 5" WC (Water Column Pressure).

Liquid Propane Manifold Pressure

The standard propane gas orifices in a conversion kit will be set for 10" WC (Water Column Pressure).

Gas Supply Pressure

- Maximum line pressure for natural gas and LP is 14" WC; 1/2 psi (3.5 kPa).
- Minimum line pressure for natural gas is 7" WC.
- Minimum line pressure for LP gas is 11" WC.

Gas Pressure Regulator

To control and maintain a uniform gas pressure in the gas manifold, Wolf gas appliances must be connected to the gas supply line through a pressure regulator. The burner orifices are sized for the pressure delivered by the regulator. Never attempt to operate a Wolf gas appliance without the use of the proper pressure regulator.

⚠ CAUTION

The maximum gas supply pressure to the regulator should never exceed 14" WC (Water Column Pressure); 1/2 psi (3.5kPa).

Leak Testing:

⚠ WARNING

NEVER USE OPEN FLAMES TO CHECK FOR GAS LEAKS. ONLY USE A COMMERCIAL LEAK DETECTION SOLUTION OR SOAP SUDS AROUND GAS CONNECTIONS TO CHECK FOR LEAKS. DO NOT USE LIQUID NEAR VALVE STEMS.

Electrical Requirements:

A Wolf gas appliance requires 110 to 120 volts AC and a 15 ampere dedicated circuit breaker to operate properly.

The power supply cord provided on the appliance is equipped with a 3-prong (grounding) plug. The installation site must be equipped with a properly grounded 3-prong receptacle. If the electric receptacle or the power cord are not properly grounded and polarized, this could cause a shock hazard and the appliance may experience ignition problems. (See Figure 3-1)

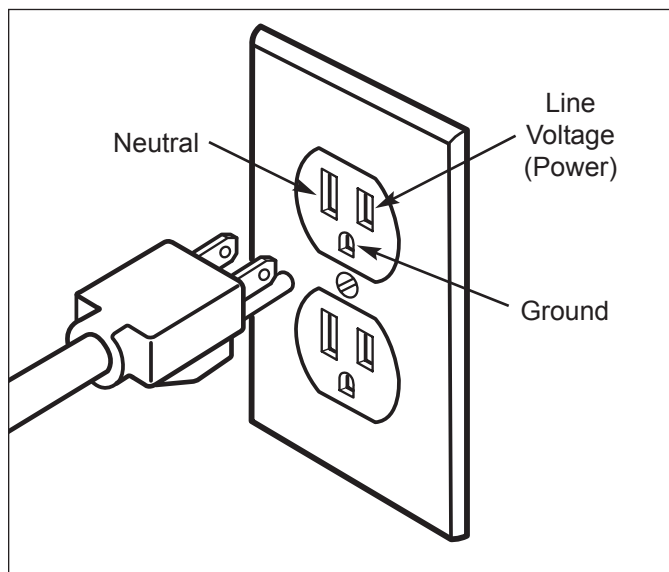

Figure 3-1. Proper Polarity at Electric Receptacle

⚠ WARNING

TO AVOID SHOCK HAZARD, NEVER REMOVE THE GROUND PRONG FROM THE PLUG OF THE POWER SUPPLY CORD.

Unit Blocking:

Wolf ranges can tip forward under certain load conditions. The anti-tip wall bracket must be attached to the wall behind the appliance so that it is directly above the bottom rear brace when the range is fully installed. (See Figure 3-2)

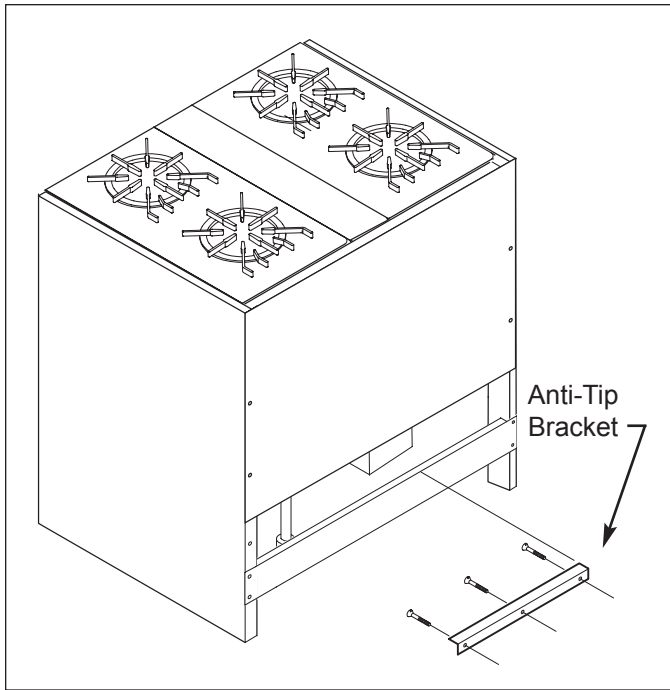

Figure 3-2. Anti-Tip Wall Bracket Installation

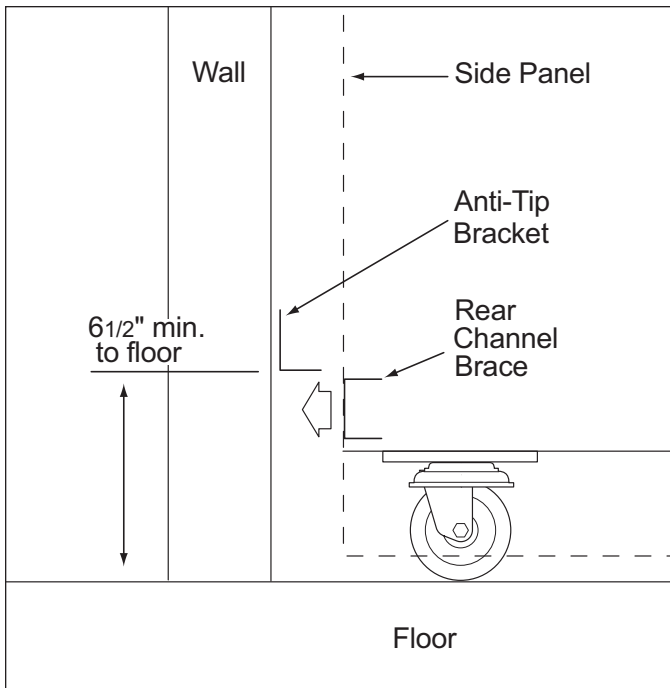

Figure 3-2. Anti-Tip Wall Bracket Installation

Unit Leveling:

Wolf ranges can be leveled at the front by adjusting the 3" (76 mm) adjustable front legs. (See Figure 3-3)

In order to level the rear of the unit, use the caster wrench (p/n 803239), to rotate the 2-5/16" (59 mm) nut clockwise to raise or counterclockwise to lower the unit. (See Figure 3-4)

Use shims to level a wolf rangetop.

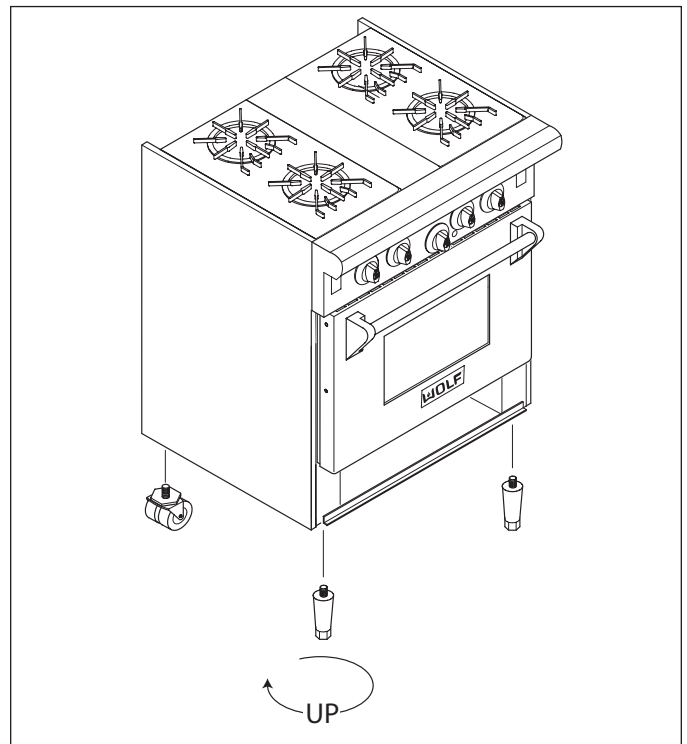

Figure 3-3. Unit Leveling, Front Leveling Leg

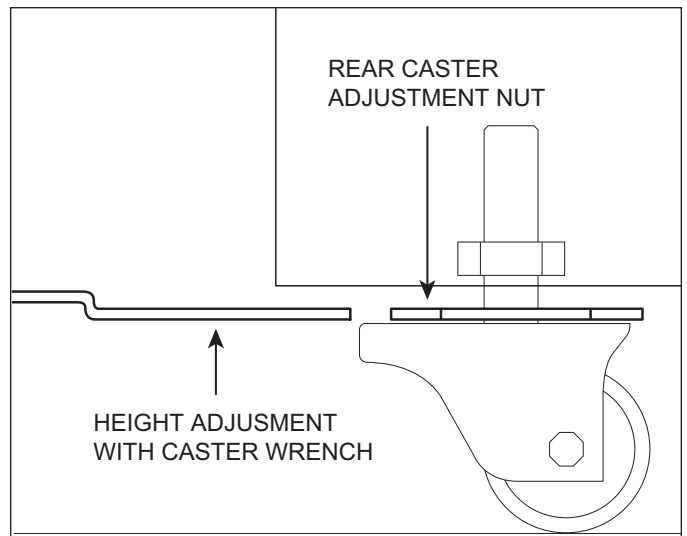
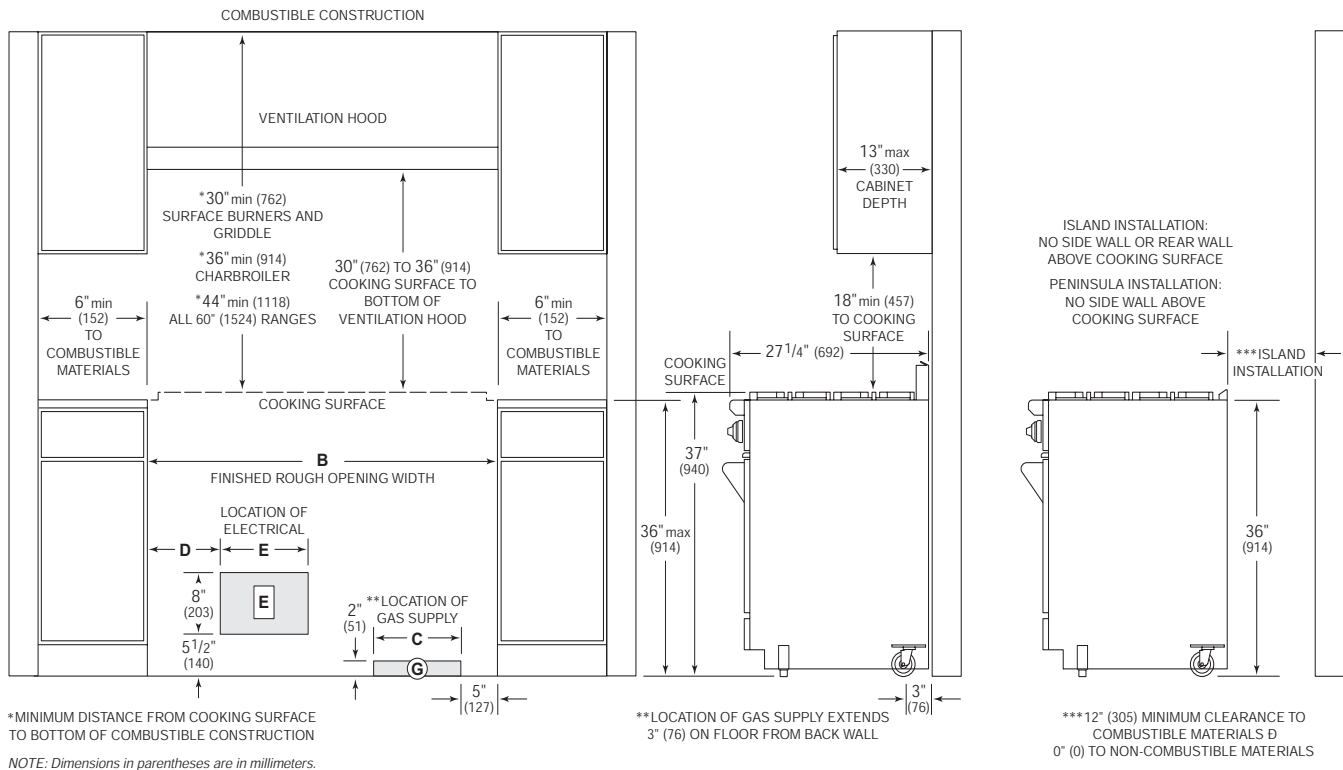
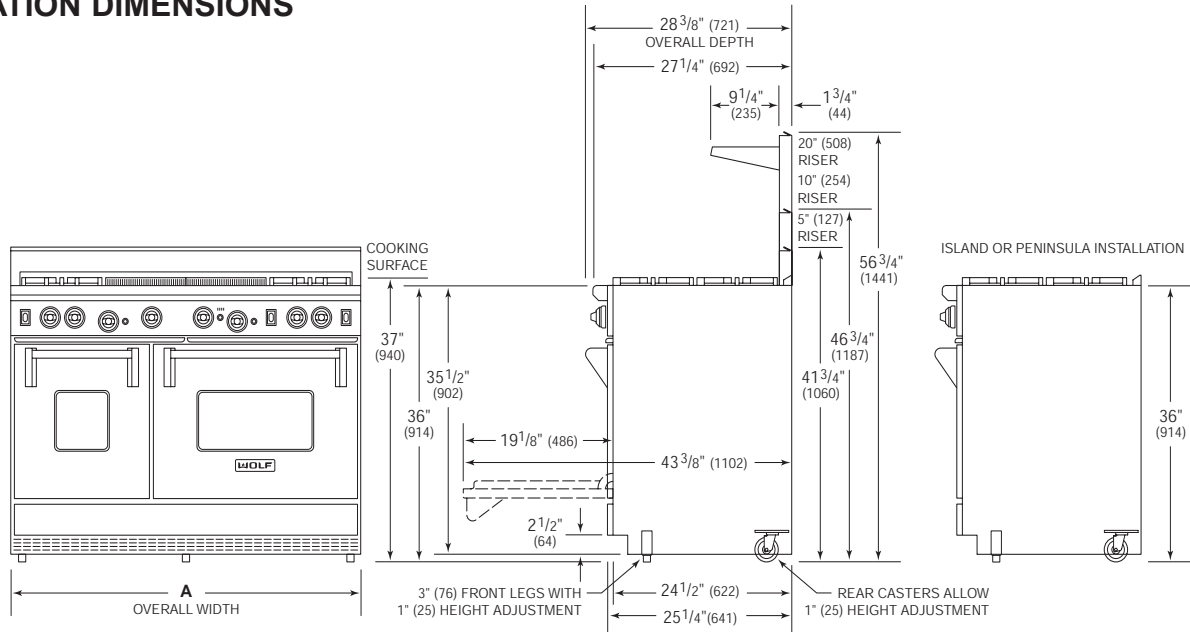

Figure 3-4. Unit Leveling, Rear Caster Adjustment

INSTALLATION DIMENSIONS

RANGES



	30" Range	36" Range	48" Range	60" Range
A Overall Width of Range (width may vary to +1/4")	30"(762)	36"(914)	48"(1219)	60"(1524)
B Finished Rough Opening Width	30 1/4"(768)	36 1/4" (921)	48 1/4"(1226)	60 1/4"(1530)
C Location of Gas Supply (within shaded area)	12"(305)	10"(254)	12"(305)	12"(305)
D Location of Electrical	10"(254)	10"(254)	26"(660)	10"(254)
E Location of Electrical (within shaded area)	12"(305)	12"(305)	12"(305)	12"(305)

INSTALLATION DIMENSIONS

RANGETOPS

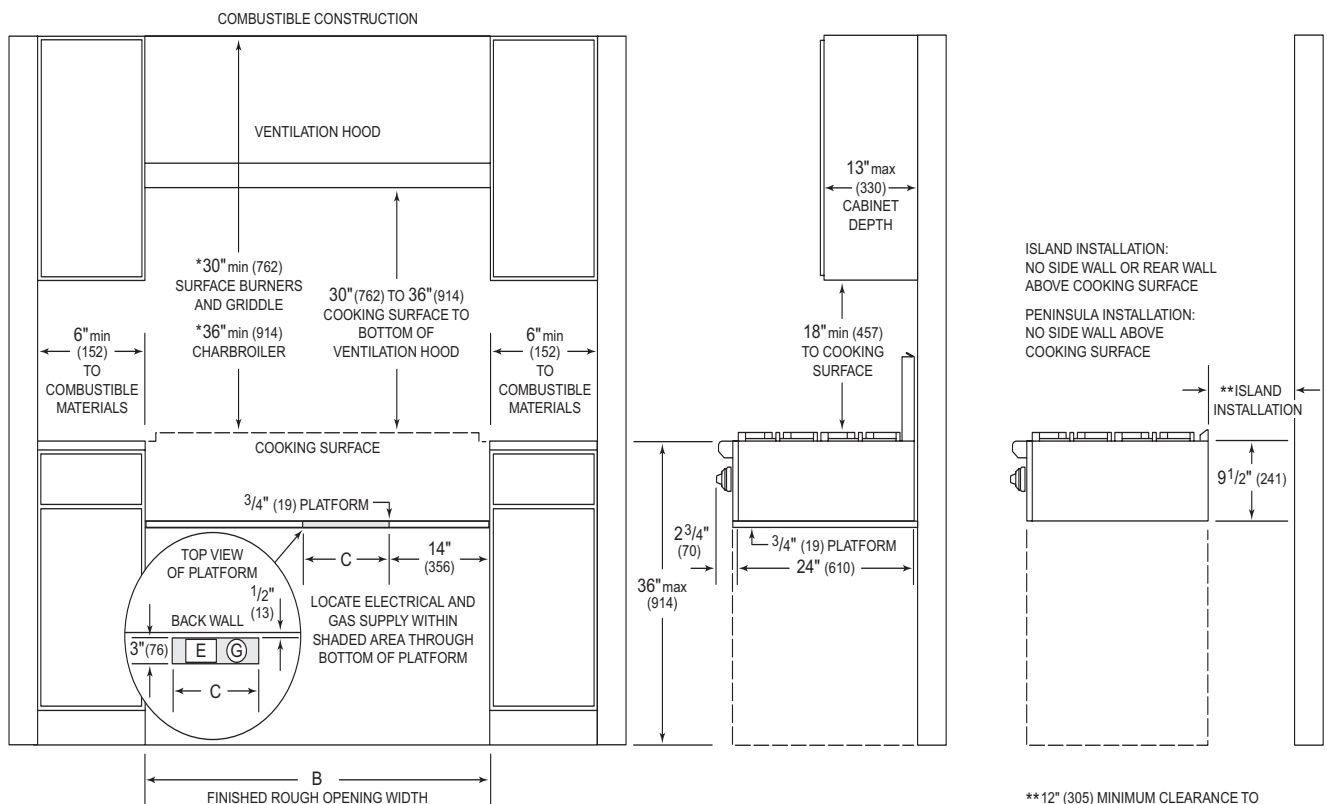
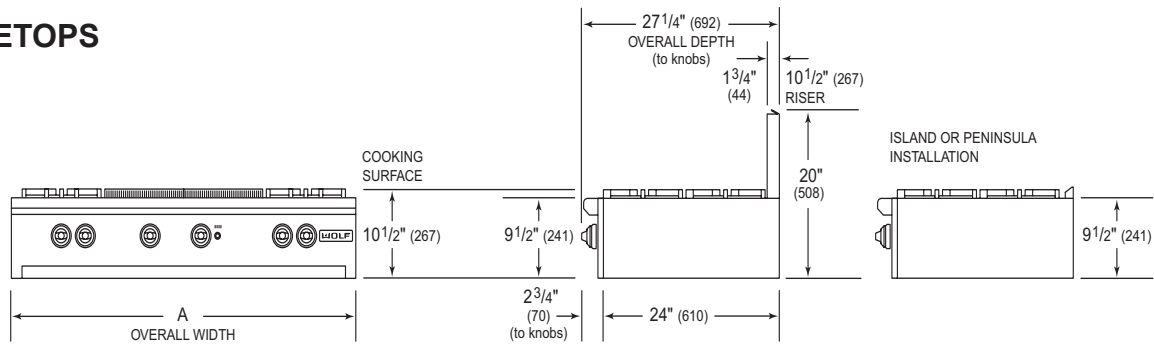

*MINIMUM DISTANCE FROM COOKING SURFACE TO BOTTOM OF COMBUSTIBLE CONSTRUCTION

NOTE: Dimensions in parentheses are in millimeters.

**12" (305) MINIMUM CLEARANCE TO COMBUSTIBLE MATERIALS & 0" (0) TO NON-COMBUSTIBLE MATERIALS

	36" Rangetop	48" Rangetop
A Overall Width of Rangetop	36" (914mm)	48" (1219mm)
B Finished Rough Opening Width	36 1/4" (921mm)	48 1/4" (1226mm)
C Location of Gas Supply and Electrical	8" (203mm)	16" (406mm)

SECTION 4

**COMPONENT
ACCESS AND REMOVAL**

COMPONENT ACCESS AND REMOVAL

This section explains how to access and remove components from a Wolf range and rangetop.

NOTE: Before attempting to access or remove any components from a Wolf appliance, take note of the **WARNINGS** and **CAUTIONS** below.

⚠ WARNING

TO AVOID SERIOUS BURNS AND/OR EXPLOSIONS, KEEP COMBUSTIBLES AWAY FROM THE APPLIANCE WHENEVER A FLAME IS PRESENT. KEEP IN MIND THAT OVEN SURFACES AND COMPONENTS GET HOT DURING USE OF THE APPLIANCE. IF THE OVEN IS SWITCHED ON DURING SERVICE, KEEP YOUR FACE AWAY FROM THE DOOR WHEN OPENING IT.

TO AVOID ELECTRIC SHOCK, POWER TO THE UNIT MUST BE DISCONNECTED WHENEVER ACCESSING AND/OR REMOVING COMPONENTS POWERED BY ELECTRICITY OR COMPONENTS NEAR OTHER ELECTRICAL COMPONENTS.

IF IT IS NECESSARY TO REMOVE A UNIT FROM ITS INSTALLATION, REMEMBER THAT THE UNIT COULD TIP FORWARD WHEN PULLED FORWARD BEYOND THE ANTI-TIP COMPONENTS, RESULTING IN SERIOUS INJURY OR DEATH. PULLING A UNIT FROM ITS INSTALLATION SHOULD ONLY BE PERFORMED BY AN AUTHORIZED SERVICE TECHNICIAN OR INSTALLER.

⚠ WARNING

WHEN REASSEMBLING GAS SUPPLY LINE TO REGULATOR, ONLY PIPE THREAD COMPOUND SHOULD BE USED. DO NOT USE TEFLON TAPE TO SEAL GAS PIPE CONNECTIONS.

⚠ WARNING

WHEN REASSEMBLING REGULATOR TO MANIFOLD, ONLY PIPE THREAD COMPOUND SHOULD BE USED. DO NOT USE TEFLON TAPE TO SEAL GAS CONNECTIONS.

⚠ CAUTION

- If removing or disconnecting the door spring, remember it could recoil quickly when released.

Surface Burner Components:

Surface Burner Grate, Inner Burner, Outer Burner Ring & Outer Burner Base Removal

- Lift the burner grate from the pressed steel top.
 - Lift the inner burner from the inner burner base.
 - Lift the outer burner ring from the outer burner base.
 - Lift the outer burner base from the burner body.
- (See Figure 3-1)

Surface Burner Pressed Steel Top Removal

After the grates are removed, the pressed steel top can be removed by placing the vinyl coated end of the “S” hook removal tool (supplied with the unit) into one of the oblong holes in the steel top and lifting up. (See Figure 3-2)

Surface Burner Body Removal

In order to remove the Burner Body, the components listed above will need to be removed first, and the unit will need to be pulled from its installation so that the back panel can be removed.

Once the back panel is removed, disconnect the appropriate electrode wire from the spark module and clip any cable ties around the wire being removed.

With wrenches, disconnect the inner burner gas supply line from the burner body. (See Figure 3-3)

With one wrench on the outer burner orifice holder, use another wrench to disconnect the flexible gas line which supplies the outer burner. (See Figure 3-4)

Extract the burner body mounting screws with a Phillips head screwdriver and lift the burner body from the appliance, along with the electrode wire.

NOTE: The inner burner base can be removed from the burner body with a large Allen wrench.

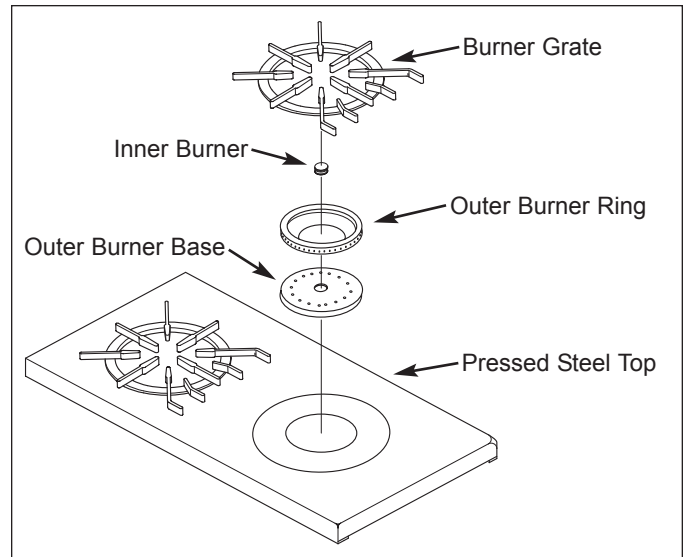

Figure 3-1. Components that Lift Off

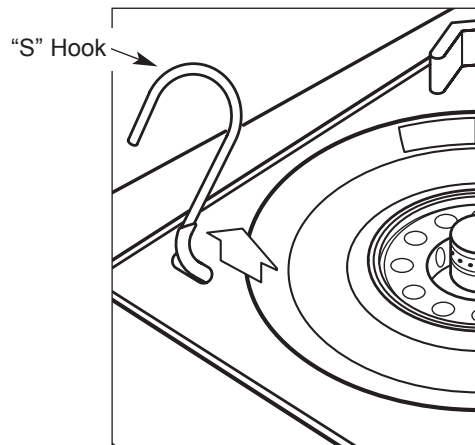

Figure 3-2. Steel Top Removal

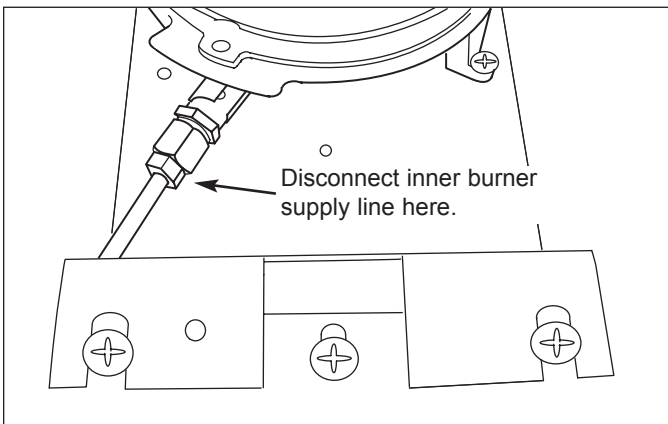

Figure 3-3. Disconnect Inner Burner Supply Line

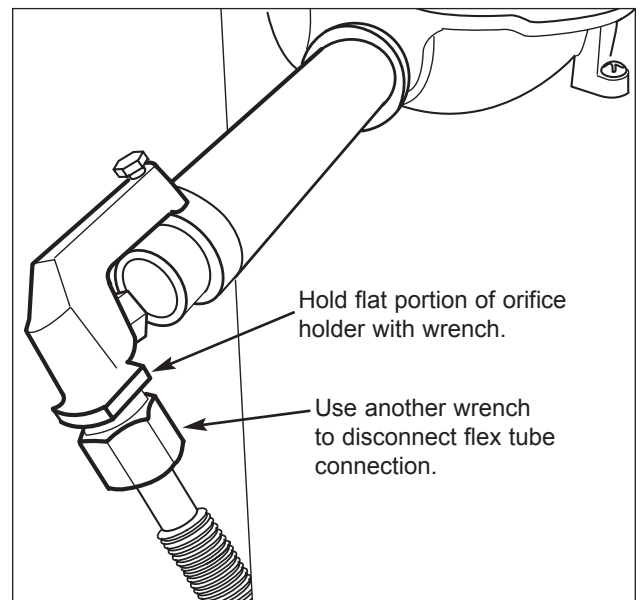

Figure 3-4. Disconnect Outer Burner Supply Line

Surface Burner Orifice Removal

Outer - The outer burner orifice is hex shaped and attached to the orifice holder near the inlet of the venturi tube. Use a wrench to remove it. (See Figure 3-5)

Inner - The inner burner orifice is small and bell-shaped. It is located inside the inner burner mixing tube and held in place by the gas line brass fitting. To remove the orifice, use a wrench to disconnect the brass fitting from the mixing tube. Then, use a flat-blade screwdriver to reach into the mixing tube and knock the orifice out. (See Figure 3-5)

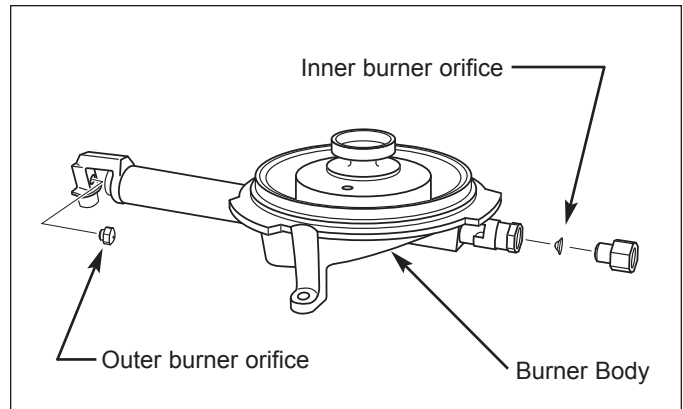

Figure 3-5. Surface Burner Orifice Removal

Surface Burner Electrode Removal

The surface burner electrode is attached to the burner body using an E-ring and a retaining spring at the bottom side of the burner body. The electrode wire is inserted down through a mounting hole in the burner body and through the retaining spring. When the electrode is installed down fully into the mounting hole, the retaining spring is pushed up tight to the bottom of the burner body and compressed slightly. The E-ring is placed behind the retaining spring into a groove on the base of the electrode. (See Figure 3-6) The electrode wire is then inserted into a wire sleeve and routed to the spark module which is located on the back side of the unit.

In order to remove a surface burner electrode, the unit must be pulled from its installation and the back panel must be removed. Once the back panel is removed, disconnect the appropriate electrode wire from the spark module. Then, using an 10mm allen wrench, remove the inner burner base.

Access the bottom of the burner body and locate the E-ring at the base of the electrode. Remove the E-clip using a small flat-blade screwdriver. Then, pull the electrode and its wire out from the wire sleeve and up through the burner body. (See Figure 3-6)

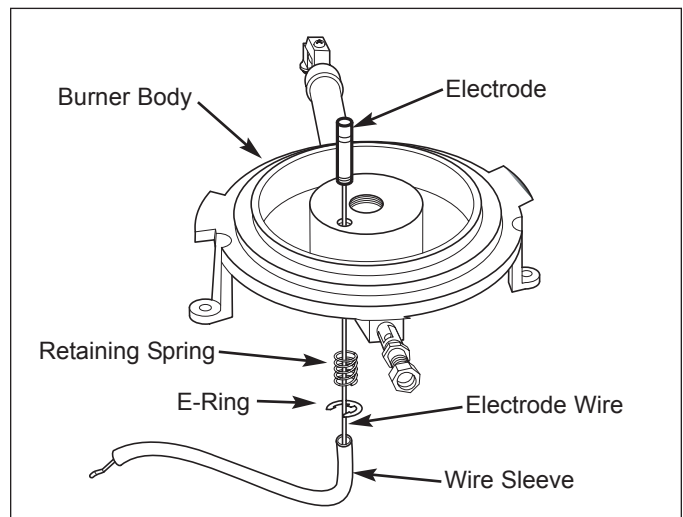

Figure 3-6. Surface Burner Electrode Removal

Surface Burner Support Removal

The burner body will need to be disconnected from the top of the surface burner support before attempting to remove the support. But, do not extract the support mounting screws until a pencil has been used to mark the position of the locator holes and the edge of the support at front and rear. (See Figure 3-7)

NOTE: These markings will assist in proper location of the support when reinstalling. Failure to mark the location before removal could cause burner alignment problems when reinstalling the support.

After marking the support location, use a Phillips head screwdriver to remove the four mounting screws, two at front and two at rear. Then lift the support from the top of the appliance.

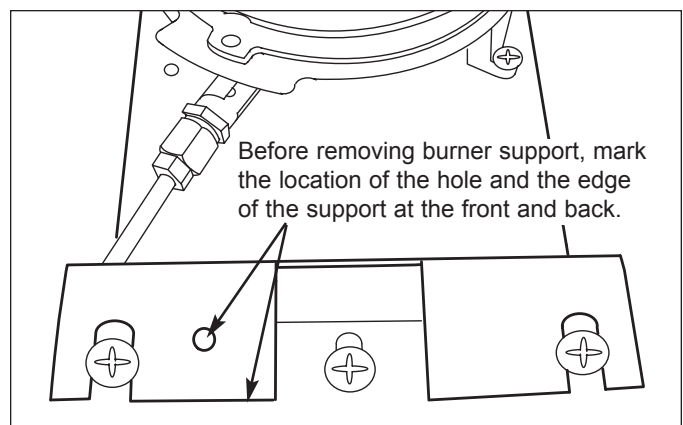

Figure 3-7. Mark Location Of Burner Support

Infrared Charbroiler Components:

Infrared Charbroiler Cover, Cover Spacer, Grate, Screen, Blank-off Plate & Charbroiler Frame Removal

- Lift the Charbroiler cover from the broiler frame.
- Lift the Charbroiler cover spacer from the broiler frame.
- Lift the Charbroiler grille from the broiler frame.
- Lift the Charbroiler screen from the burner box.
- Lift the Charbroiler blank-off from the burner box.
- Lift the Charbroiler frame from the top of the unit.
(See Figure 3-8)

Infrared Charbroiler Orifice Removal

The orifice is located in the brass orifice elbow, which is threaded into the orifice holder at the front of the burner box.

NOTE: *It is possible to access and remove the orifice without lifting out the infrared burner box, however lifting the box out first will make the task easier.*

To remove the orifice, first remove the heat shield and disconnect the gas line from the brass orifice elbow. Then, unscrew the elbow from the orifice holder, and extract the orifice from the elbow with wrenches. (See Figure 3-9)

Infrared Charbroiler Burner Box Removal

After removing the components listed above, extract the screw securing the sparker bracket. Then, extract the screw from the rear of the IR burner box. Extract the screws from the heat shield/baffle and lift it out. Disconnect the gas line from the brass orifice elbow and lift the burner box out. (See Figure 3-10)

Infrared Charbroiler Sparker Removal

The infrared Charbroiler sparker is attached to a bracket with a screw and then mounted 1/32" above the surface of the burner tile. The sparker wire is then inserted into a wire sleeve and routed to the spark module which is located on the back side of the unit.

In order to remove the Charbroiler sparker, the unit must be pulled from its installation and the back panel must be removed.

Once the back panel is removed, disconnect the sparker wire from the module. Extract the mounting screw from the sparker bracket and pull the sparker wire up through oblong hole in the back wall. (See Figure 3-10 & 3-16)

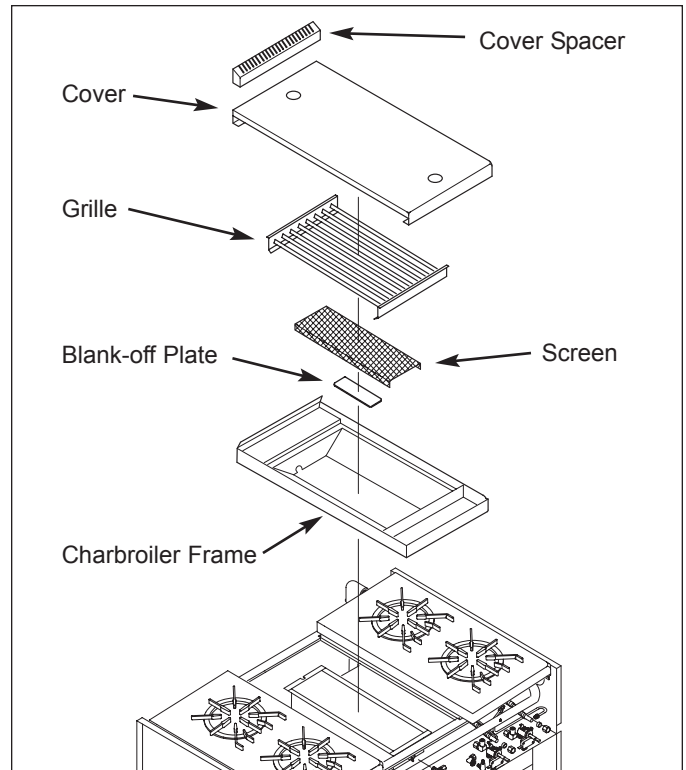

Figure 3-8. Components that Lift Off

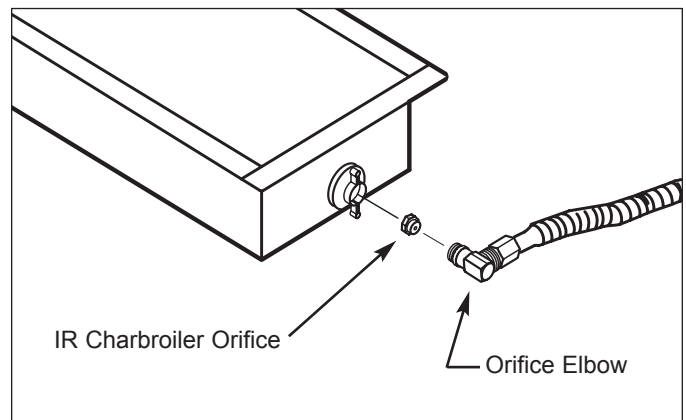

Figure 3-9. IR Charbroiler Orifice Removal

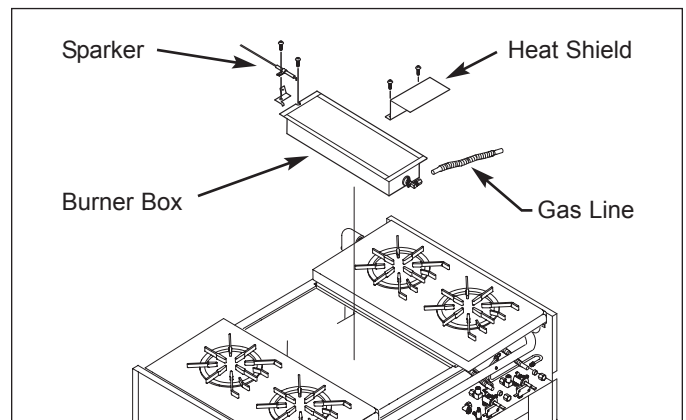

Figure 3-10. IR Charbroiler Burner & Sparker

Infrared Griddle Components:

Infrared Griddle Plate Removal

The griddle plate rests on top of the unit frame. A rigid drain spout is welded to the bottom front of the griddle plate and leads down to the grease trap on the drip pan. A channel is welded to the bottom of the griddle plate into which the griddle thermostat bulb is inserted.

11" Griddle Plate with Riser - To remove an 11" griddle plate from a unit with a riser, first remove the surface burner pressed steel tops at either side of the griddle. Then, lift the griddle plate until the front edge clears the top of the roll front. Then, rotate the plate until the back corner clears the face of the riser.

NOTE: Care should be taken at this time to avoid scratching the roll top or riser.

Lift the griddle straight up until the drain spout clears the unit frame. Now, tilt the griddle plate forward until it is vertical and lift straight up to disengage the thermostat bulb from the channel. (See Figure 3-11)

22" Griddle Plate with Riser - If the appliance is equipped with a 22" griddle and a riser, the unit will need to be pulled from its installation and the riser removed in order to remove the griddle plate. Then, lift the plate straight up until the drain spout clears the unit frame. Now, tilt the griddle plate forward until it is vertical and lift straight up to disengage the thermostat bulb from the channel. (See Figure 3-11)

Infrared Griddle Orifice Removal

The orifice is located in the brass orifice elbow, which is threaded into the orifice holder at the front of the burner box.

NOTE: It is possible to access and remove the orifice without lifting out the infrared burner box, but lifting the box out first will make the task easier.

To remove the orifice, first remove the heat shield and disconnect the gas line from the brass orifice elbow. Then, unscrew the elbow from the orifice holder, and extract the orifice from the elbow with wrenches. (See Figure 3-12)

Infrared Griddle Burner Box Removal

After removing the griddle plate, extract the screw securing the sparker bracket. Then, extract the screw from the rear of the IR burner box. Extract the screws from the heat shield/baffle and lift it out. Disconnect the gas line from the brass orifice elbow and lift the burner box out. (See Figure 3-13)

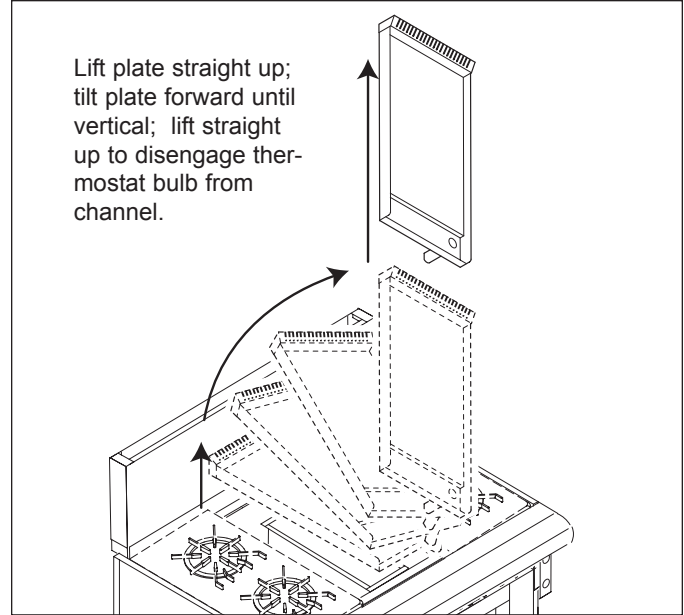

Figure 3-11. Griddle Plate Removal

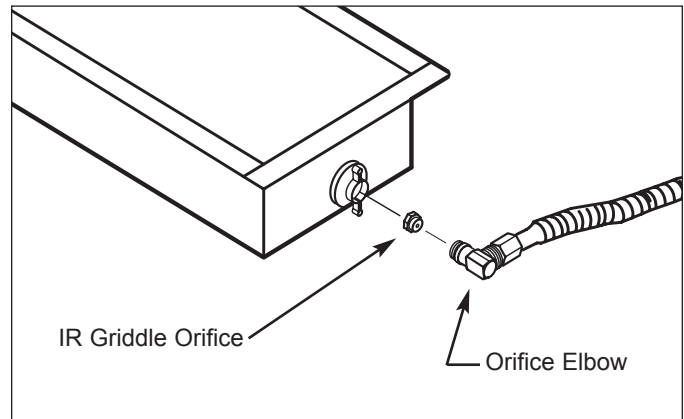

Figure 3-12. IR Griddle Orifice Removal

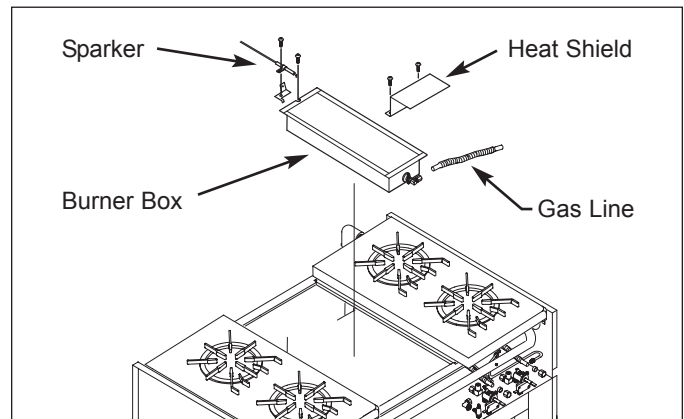

Figure 3-13. IR Griddle Burner Box Removal

Infrared Griddle Solenoid Valve Removal

The griddle solenoid valve is mounted to the side wall beneath the open burner pressed steel top, usually on the left hand side.

In order to remove the solenoid, the surface burner components will need to be removed first. Extract the solenoid shield mounting screws and remove the shield. Disconnect the gas lines from the brass elbows and the elbows from the valve body. Now, extract the bolts from the solenoid mounting bracket and pull the solenoid from the unit. (See Figure 3-14)

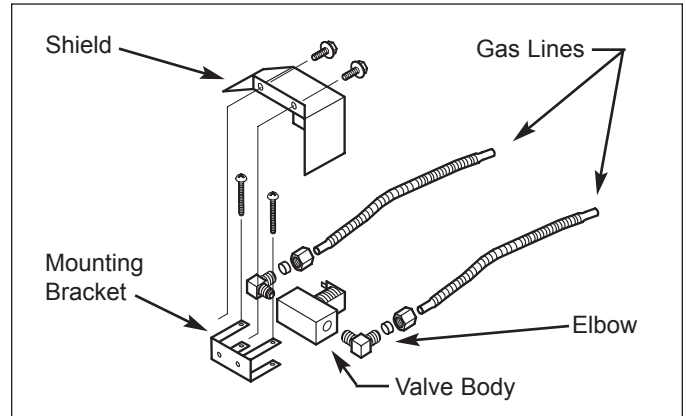

Figure 3-14. IR Griddle Solenoid Removal

Infrared Thermostat Removal

The griddle thermostat is mounted to the control panel with two screws and the thermostat bulb is inserted into a channel welded to the bottom of the griddle plate.

To remove the thermostat, first disconnect the control panel from the unit (*See Control Panel Removal Instructions*) and tilt the top of the panel down. Unplug the electrical leads from the thermostat. Pull the control knob from the shaft of the thermostat and extract the thermostat mounting screws. Pull the thermostat bulb from the channel at the bottom of the griddle plate and lift the thermostat from the unit. (See Figure 3-15)

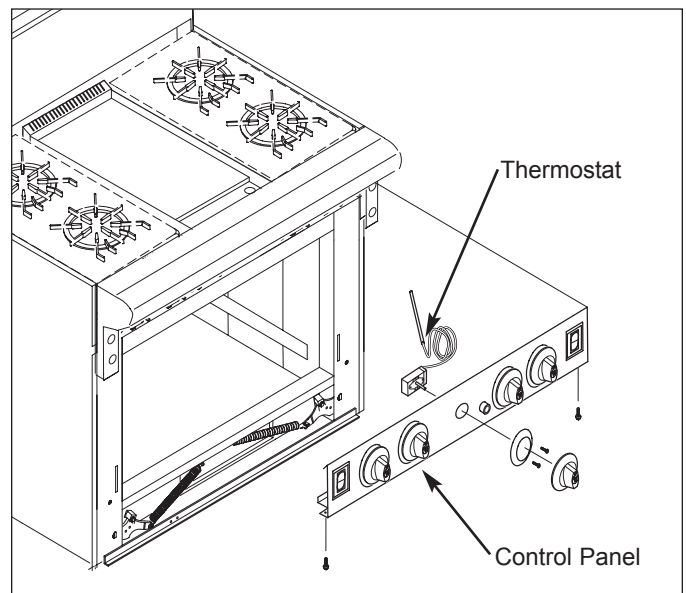

Figure 3-15. IR Griddle Thermostat Removal

Infrared Griddle Sparker Removal

The infrared griddle sparker is attached to a bracket with a screw and then mounted 1/32" above the surface of the burner tile. The sparker wire is then inserted into a wire sleeve and routed to the spark module which is located on the back side of the unit.

In order to remove the griddle sparker, the griddle plate must be removed, the unit must be pulled from its installation and the back panel must be removed.

Once the back panel is removed, disconnect the spark-er wire from the module. Extract the mounting screw from the sparker bracket and pull the sparker wire up through the oblong hole in the back wall. (See Figure 3-16)

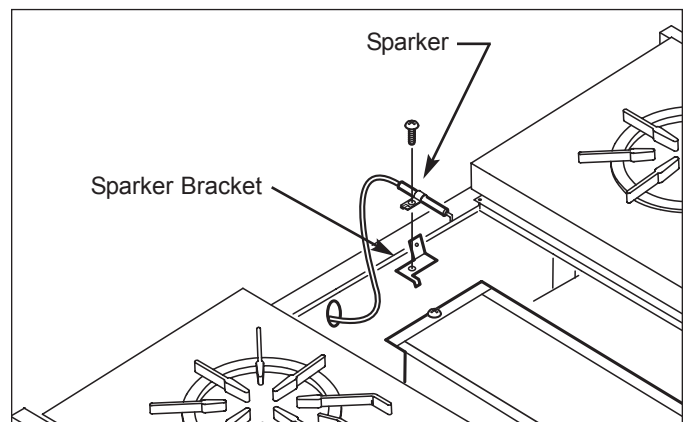

Figure 3-16. IR Griddle Sparker Removal

French Top Components:

French Top Burner Rings, Top Plate, Porcelanized Spacer, Flame Ring & Burner Head Removal

- Lift the center ring from the second ring, using the French Top hook provided with the appliance.
- Lift the second ring from the third ring.
- Lift the third ring from the top plate
- Lift the top plate from the appliance.
- Lift the porcelanized spacers from the appliance.
- Lift the flame ring off burner pan.
- Lift the burner head off of the burner.
(See Figure 3-17)

French Top Burner Pan Removal

After removing the components listed above, extract the screws at front, back and sides of the burner pan. Then, lift the front of the pan up.

NOTE: *If the burner pan has been riveted in place, the rivets will need to be drilled out. When reinstalling the burner pan 1/8" rivets may be used, or #10-24X1/2" screws (part #730228) can be installed.*

From under the burner pan, disconnect the electrode wire terminal from the electrode. Disconnect the gas line from the orifice holder at the bottom of the pan and lift the pan off of the appliance. (See Figure 3-18)

French Top Electrode & Electrode Wire Removal

Electrode - Begin removing the electrode by disconnecting the electrode wire terminal from the electrode. Remove the retaining clip from the bottom of the electrode and pull the electrode up out of its mounting hole. (See Figure 3-18)

Electrode Wire - The French Top electrode wire has a terminal at one end that fits onto the base of the electrode. The other end of the wire is inserted into a wire sleeve and routed to the spark module which is located on the back side of the unit.

In order to remove the French Top electrode wire, the unit must be pulled from its installation and the back panel removed. Then, disconnect the electrode wire terminal from the electrode and unplug the other end of the wire from the spark module. (See Figure 3-18)

French Top Orifice Removal

The French Top burner orifice is hex shaped and attached to the orifice holder/jet holder at the bottom of the burner pan.

Use wrenches to remove the orifice from the holder.
(See Figure 3-19)

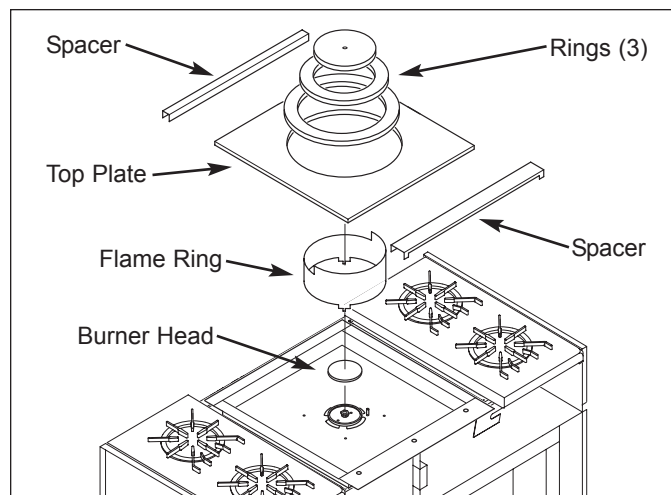

Figure 3-17. Components that Lift Off

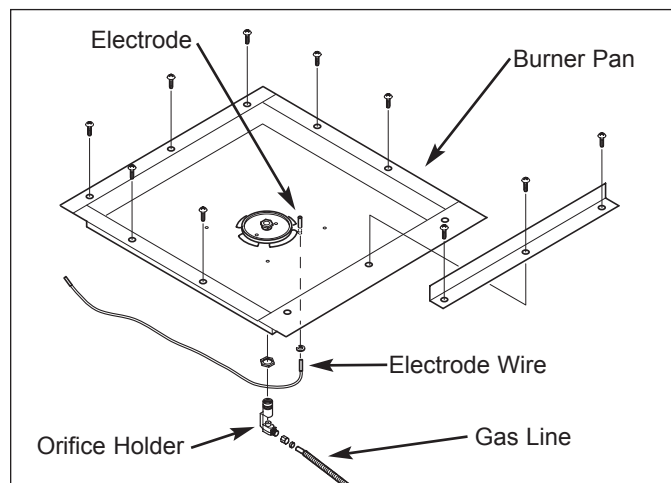

Figure 3-18. French Top Burner Pan Removal

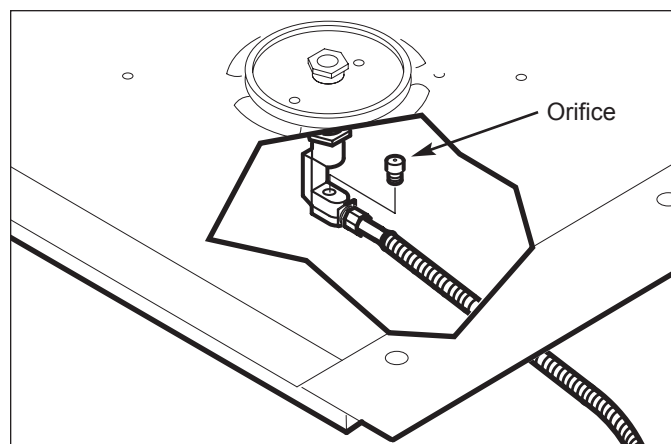

Figure 3-19. French Top Orifice Removal

Control Panel Components:

Control Panel Removal

NOTE: If servicing a rangetop, it will need to be pulled forward slightly to access the control panel mounting screws.

Begin removing a control panel by pulling all of the control knobs from the valve shafts. Extract the screws from the bottom left and right corners of the panel. Pull the bottom of the control panel out about thirty degrees and lift slightly to disengage the top flange of the panel from its mounting. Then, tilt the top forward. (See Figure 3-20)

To completely remove the control panel, the control knobs must be pulled from the thermostats. Then, extract all thermostat mounting screws and unplug all electrical leads from the lights and switches. (See Figure 3-20 & 3-21)

Fan Switch, Light Switch & Indicator Light Removal

After tilting the top of the control panel forward, a light switch, fan switch and/or indicator light can be removed by first disconnecting the electrical leads. Then, depress the tabs on the sides of the switch or light while pushing it towards the front of the panel. (See Figure 3-21)

Thermostat and Thermostat Bezel Removal

After tilting the top of the control panel forward, disconnect the electrical leads from the thermostat. Extract the thermostat mounting screws (which pass through the bezel into the thermostat bracket). Now, push the thermostat back out of the control panel. (See Figure 3-21)

NOTE: The thermostat bulb will need to be pulled from the oven compartment or griddle at this time.

Micro-Switch Removal

Surface Burner Micro-Switch - Remove a micro-switch from a surface burner valve by first disconnecting the wire leads to the switch. Then, extract the mounting screw and pull the switch from the valve. (See Figure 3-22)

Charbroiler or French Top Micro-Switch - Remove a micro-switch from a Charbroiler or French Top burner valve by disconnecting the wire leads to the switch. Then, pull the switch from the valve shaft. (See Figure 3-22)

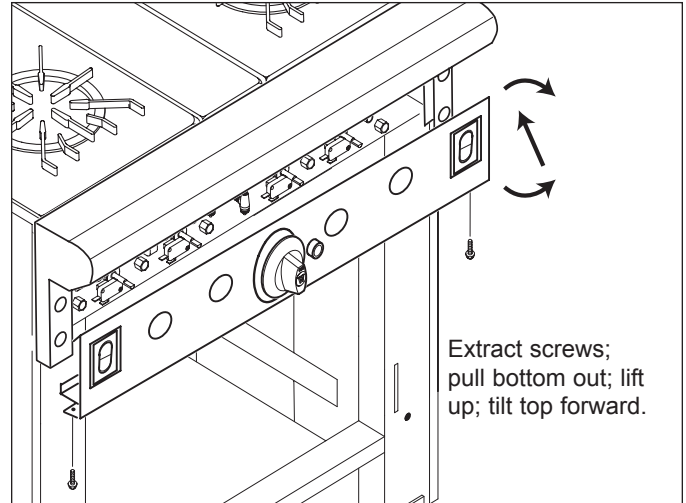

Figure 3-20. Control Panel Removal

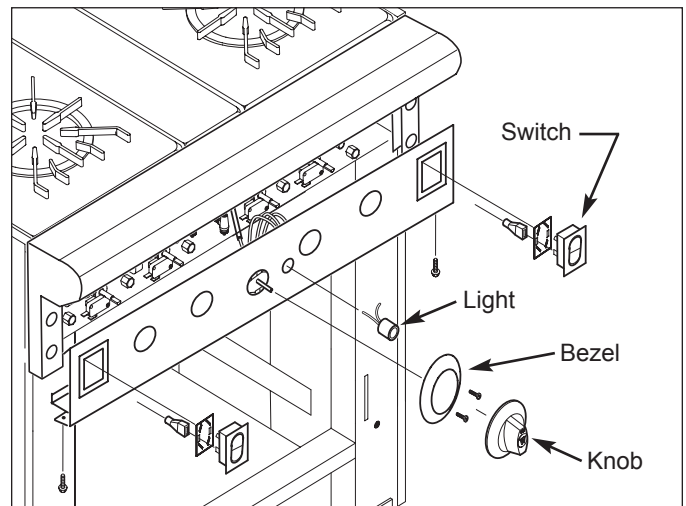

Figure 3-21. Switch, Light and Thermostat Removal

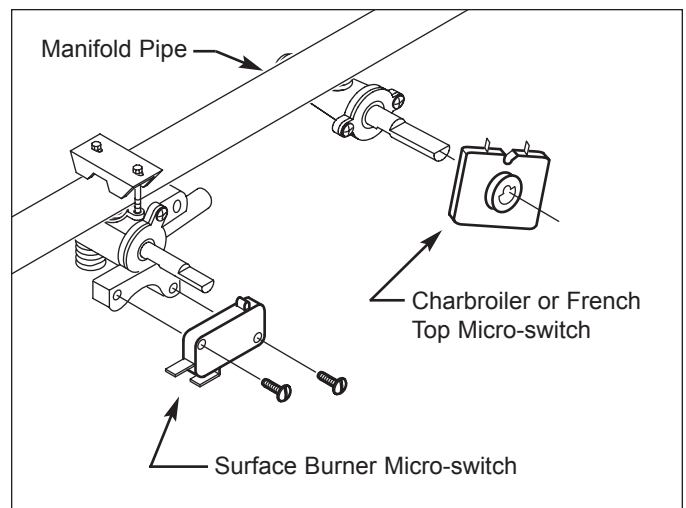

Figure 3-22. Micro-Switch Removal

Components Below the Roll Front:

Roll Front Removal

To remove the Roll Front, extract the two screws from the left and right legs of the roll top. Then extract the roll front baffle mounting screws from behind the roll front and lift the roll front and baffle off of the appliance together. (See Figure 3-23)

Surface Burner Valve Removal

Surface burner valves are held to the manifold pipe with bolts that pass down through a bracket at the top of the pipe, and are threaded into the body of the valve.

To remove a surface burner valve, first disconnect the gas lines from the valve. Then, extract the bolts from the valve body and mounting bracket. Now pull or twist the valve off of the manifold pipe.

(See Figure 3-24)

Charbroiler or French Top Valve Removal

To remove a Charbroiler or French Top valve, first disconnect the gas lines from the valve first. Then, remove the ninety degree elbow from the rear of the valve.

NOTE: Depending on the location of other components on the manifold, it may be necessary to extract the valve shaft mounting screws and pull the shaft from the valve at this point. (See Figure 3-25)

Now, unscrew the valve from the manifold pipe. (See Figure 3-25)

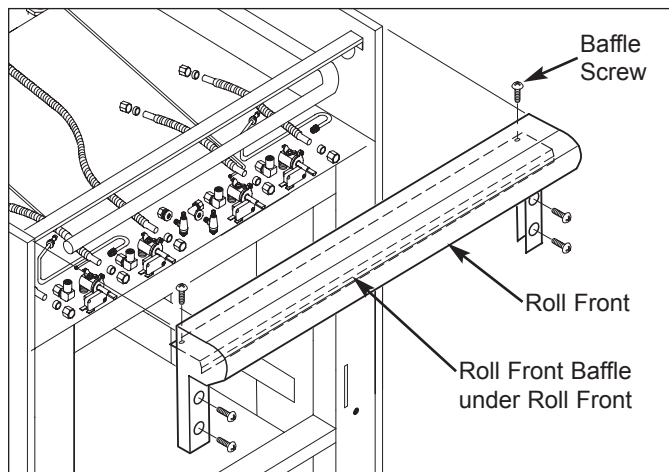

Figure 3-23. Roll Front Removal

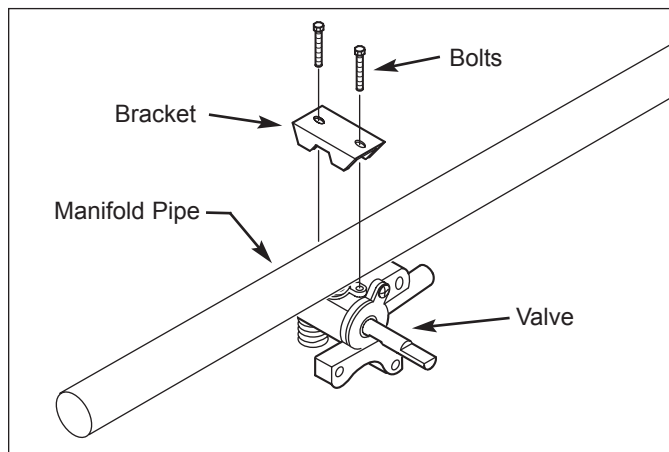

Figure 3-24. Surface Burner Valve Removal

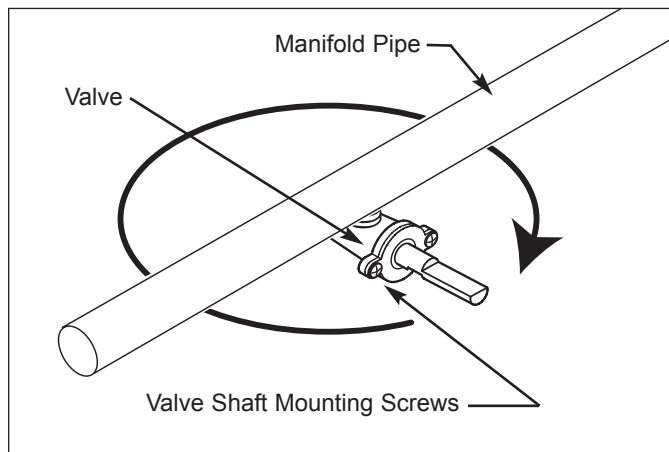

Figure 3-25. Charbroiler / French Top Valve Removal

Components Behind Lower Access Panel:

Lower Access Panel Removal

The lower access panel can be removed by extracting the mounting screws from the right and left corners of the panel and pulling the panel forward. (See Figure 3-26)

Door Switch Removal

The door switch is attached to a bracket with nuts and bolts. The bracket is then attached to the bottom frame brace with screws.

Begin removing the door switch by disconnecting the electrical leads. Then, extract the switch bracket mounting screws and pull the switch and bracket away from the unit. The switch can now be removed from the bracket by extracting the bolts from the nuts. (See Figure 3-27)

Oven Burner Bi-Metal Valve Removal

The oven burner bi-metal valve is attached to the bottom frame brace with a screw.

To remove the oven burner bi-metal valve, first disconnect the electrical leads and the gas lines. Then, extract the mounting screw and lift the bi-metal valve from the appliance. (See Figure 3-28)

Oven Burner Orifice Removal

The oven orifice is bell shaped with a hex shaped end. One end of the oven orifice elbow is inserted through a hole in the orifice fitting bracket. The orifice is then threaded onto the end of the elbow that protrudes through the bracket.

To remove the oven orifice, first remove the screws that hold the orifice fitting bracket to the bottom frame brace. Then, use wrenches to disconnect the oven orifice from the orifice elbow. (See Figure 3-28)

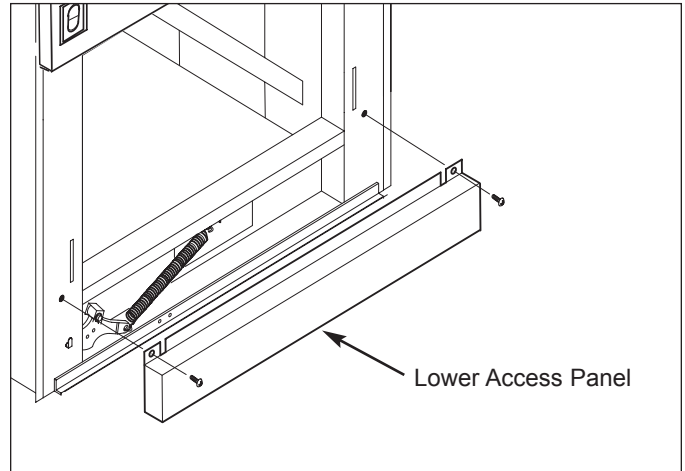

Figure 3-26. Lower Access Panel Removal

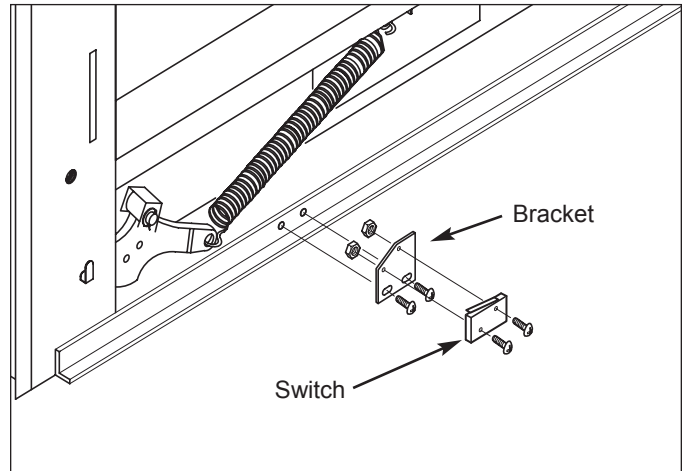

Figure 3-27. Door Switch Removal

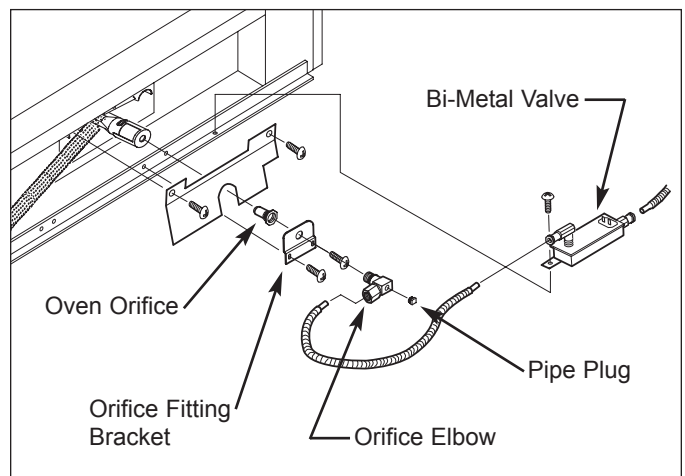

Figure 3-28. Oven Bi-Metal Valve and Oven Orifice Removal

Oven Compartment Components:

Oven Rack Removal

To remove an oven rack, pull the rack forward until it stops. Then, lift the front of rack to about a twenty-five degree angle and continue to pull the rack forward and out of the oven compartment. (No Diagram)

Oven Rack Guide Removal

The tops of the oven rack guides are hooked up into holes in the side walls, then the bottom of the rack guides are lowered down into holes in the bottom oven panel.

To remove an oven rack guide, lift it straight up, then pivot the bottom towards the center of the oven. Now, pull the rack guide down out of the holes in the side wall and out of the oven. (No Diagram)

Oven Light Components Removal

To access and remove the light components, begin by unscrewing the light lens. The light bulb can now be removed by unscrewing it from the light socket. (See Figure 3-29)

In order to remove the light socket, the unit must be pulled from its installation and the back panel removed. Then, disconnect the electrical leads from the socket terminals. With a small flat-blade screwdriver gently expand the metal tabs on each side of the ceramic socket and pull the socket out of the lamp base. (See Figure 3-29)

Oven Convection Fan Removal

The convection fan assembly is held to the back wall with screws. The fan cover is positioned in front of the fan assembly and also held to the back wall with screws.

To remove the fan assembly, first extract the fan cover mounting screws and pull the cover from the oven. Then, extract the fan assembly mounting screws and pull the fan assembly forward slightly. Disconnect the fan's electrical leads and pull the fan assembly from the oven. (See Figure 3-30)

Oven Bottom Panel Removal

To remove the bottom oven panel, extract the screws at the front and back, then lift the panel up and out of the oven. (See Figure 3-31)

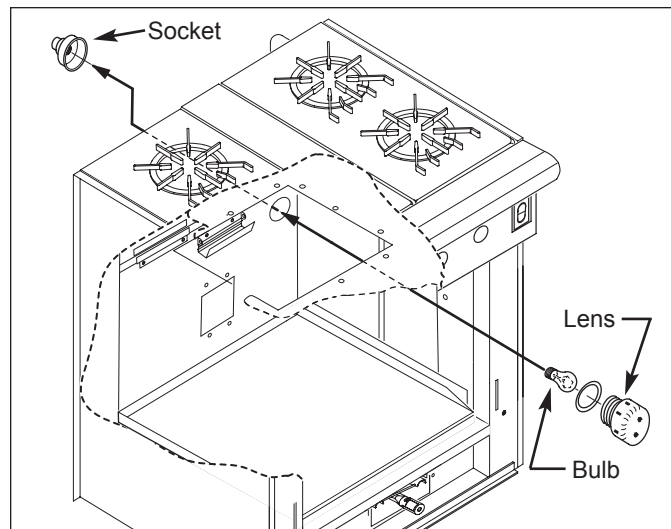

Figure 3-29. Light Components Removal

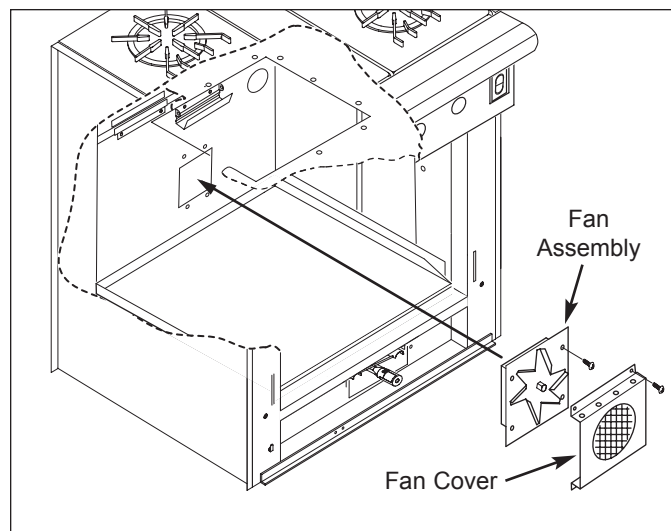

Figure 3-30. Convection Fan Removal

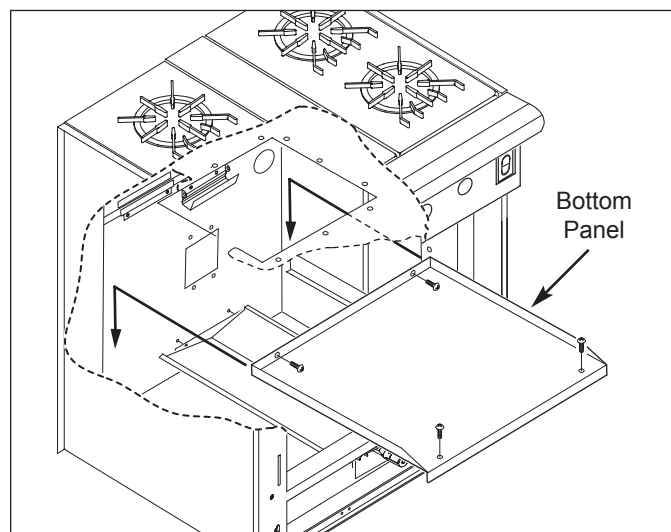

Figure 3-31. Bottom Panel Removal

Oven Flame Deflector Removal

The oven flame deflector sits on top of two deflector rests, one at the front and one at the back of the oven compartment. The screws that hold the front rest in place pass through the unit frame into the rest and help to secure the flame deflector.

Removing the flame deflector requires the lower access panel and the bottom oven panel to be removed first. Then, loosen, but do not remove, the front burner rest mounting screws and lift the deflector up and out of the oven. (See Figure 3-32)

Oven Burner Tube Removal

The oven orifice protrudes into the burner tube inlet, thus keeping the burner tube in the correct position at the front. A screw at the back of the burner tube secures the tube to the bottom of the oven compartment. The oven glow coil igniter is attached to a bracket on the side of the burner tube.

To remove an oven burner tube, the lower access panel will need to be removed. Then, disconnect the oven orifice fitting bracket from the bottom frame brace. Cut any cable ties that may be around the glow coil wires. Extract the screw at the back of the oven burner tube. Lift the rear of the burner tube slightly while pulling it towards the rear of the unit. Now, extract the glow coil igniter mounting screws, pull the igniter away from the burner tube, and lift the burner tube up and out of the oven. (See Figure 3-33)

Oven Glow Coil Igniter Removal

Two screws secure the oven glow coil igniter to a bracket on the side of the oven burner tube. One of the igniter wire leads is attached to the oven bi-metal valve and the other wire lead is connected to another wire with a butt-connector.

To remove an oven glow coil igniter, the lower access panel will need to be removed. Then, cut any cable ties that may be around the glow coil wires. Disconnect the wire lead from the bi-metal valve and cut the other wire lead just after the butt-connector. Now, lift the oven burner tube out of the oven compartment with the glow coil igniter attached. Extract the glow coil igniter mounting screws and pull the igniter away from the burner tube. (See Figure 3-33)

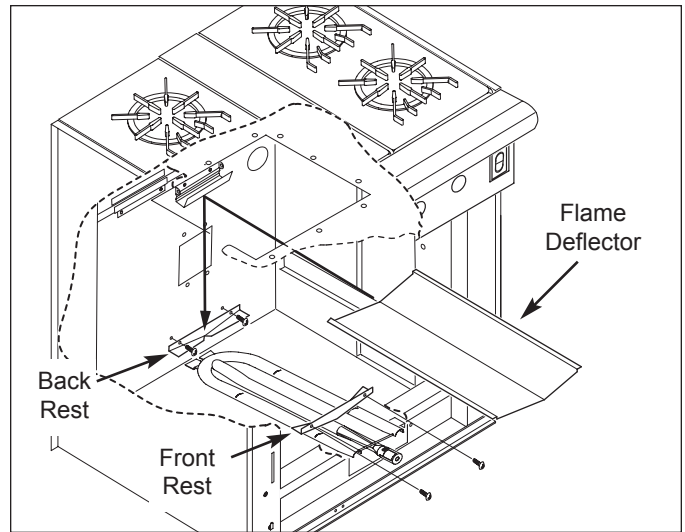

Figure 3-32. Flame Deflector Removal

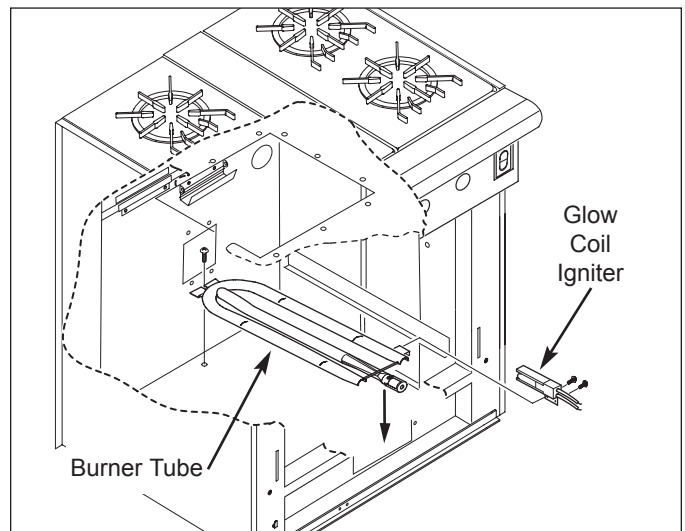

Figure 3-33. Burner Tube & Igniter Removal

Oven Broiler Glow Coil Igniter Removal

The oven broiler glow coil igniter is attached to the igniter bracket with screws and the bracket is attached to the top of the oven compartment, just under the oven broiler burner. The igniter wire leads are inserted through a wire sleeve and then routed into a hole in the side wall, then beneath the side panel and up to a molex connector under the surface burners.

Begin removing a broiler glow coil igniter by accessing the molex connector under the surface burners. With a pin extractor, push the pins on the igniter wires out of the molex connector.

NOTE: At this time it is recommended to tie a piece of string or wire (about 24" in length) to the igniter wire leads. By pulling this string down into the oven compartment with the wire leads during removal of the igniter, the string can then be attached to the wires of the replacement igniter and pulled back up to the molex connector. Failure to use this string will require the unit to be pulled from its installation and the side panel to be removed.

Now, extract the igniter bracket mounting screws from the top of the oven compartment and pull the igniter wires down and out of the hole in the oven side wall. (See Figure 3-34)

Oven Infrared Broiler Burner Removal

The broiler burner box sits in a pocket at the top of the oven. The burner mixing tube runs from the burner box to the back side of the appliance. The orifice holder bracket is welded to the back end of the mixing tube. The broiler burner is held in place by four brackets placed over the edges of the burner box. The brackets are then secured to the top of the oven with screws.

In order to remove the broiler burner, the unit must be pulled from its installation and the back panel and flue removed. Then, disconnect the gas line from the orifice elbow and remove the orifice elbow from the holder. Pull the broiler mixing tube out through the back side of the unit. Inside the oven, disconnect the glow coil igniter from the top of the oven. Extract the burner bracket mounting screws. Now, lower the broiler burner down at the front slightly, then pull it forward, down and out of the oven. (See Figure 3-34)

NOTE: The mixing tube must be replaced with the burner box. This is supplied as an assembly for service. When inserting the mixing tube back into the burner box, make sure that the tube is inserted fully to rest against brackets inside the burner box.

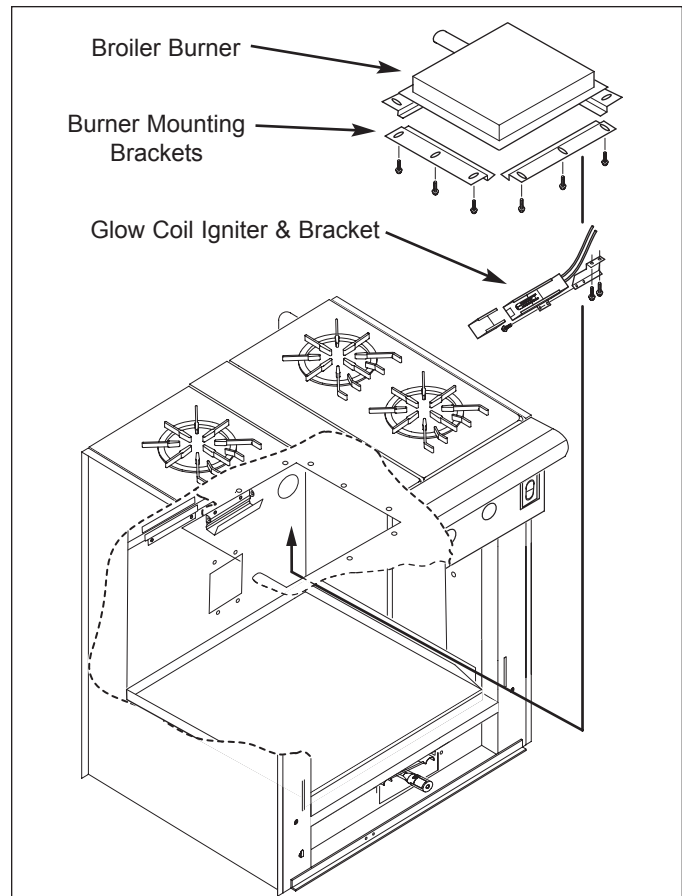

Figure 3-34. Broiler Burner & Igniter Removal

Oven Door Components:

Oven Door Assembly Removal

To remove an oven door, first relieve the tension of the door spring using a channel-lock wrench between the eye-bolt and mounting bracket. Squeeze the channel-lock wrench together and remove the nut from the eye-bolt. Now, when the channel-lock wrench is released, the spring tension will be relieved and the S-hook can be removed from the rocker arm and the door hinge. Then, extract the two inner hinge pin mounting screws from the bottom of the door and loosen, but do not remove the two outer hinge pin mounting screws. (See Figure 3-35) After loosening the screws, disengage the hinge pin from the trunion bolt using a nut-driver to slide the two outer hinge pin mounting screws towards the center of the door. Now, lift the door assembly off of the unit. (See Figure 3-35)

Disassembling Oven Door

If it is necessary to access or remove any of the components that make up the door assembly, extract all of the screws around the edge of the door and pull the door skin from the liner. This will allow removal of all door assembly components. (See Figure 3-36)

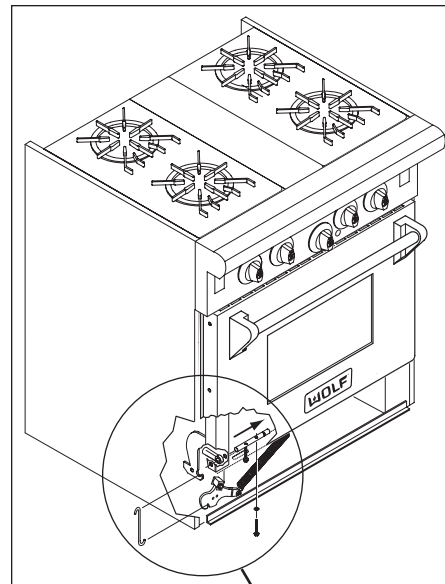

Figure 3-35.
Door Assembly Removal

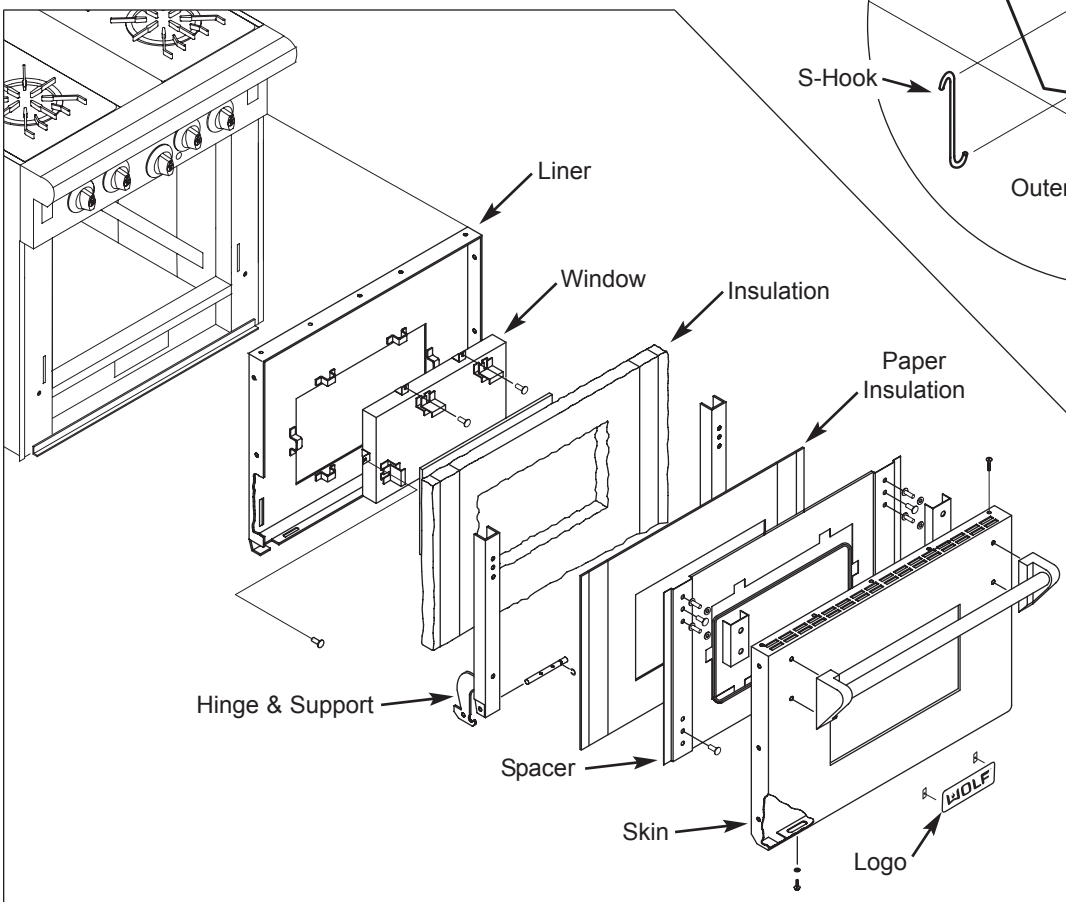
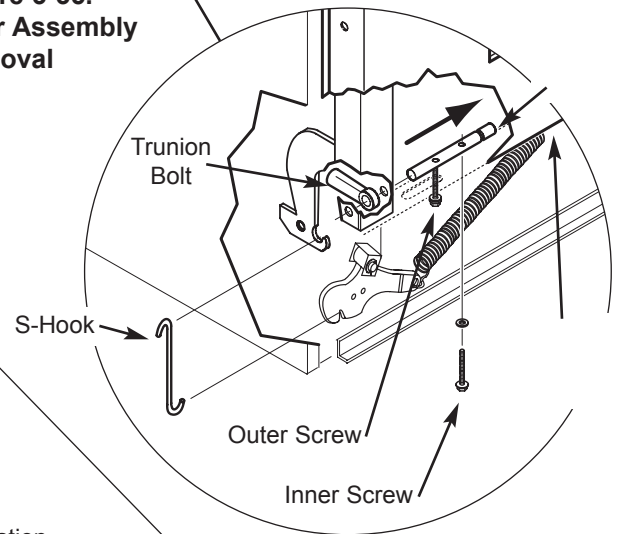

Figure 3-36. Disassembling Oven Door

Side Panels & Components on Rear of Unit:

NOTE: To remove side panels and components on rear of unit, the appliance must be pulled from its installation.

Side Panel Removal

Remove a side panel by first extracting the screws from the panel's back flange. Then, remove the screw at the bottom of the front flange. Now, pivot the back flange from the unit while sliding the panel forward. (See Figure 3-37)

Oven Bi-Metal Valve Removal

To remove the oven broiler bi-metal valve, disconnect the electrical leads and the gas lines from the valve. Then, extract the mounting screw and lift the bi-metal valve from the bracket. (See Figure 3-37)

Oven Broiler Orifice Removal

The broiler orifice is hex shaped and located in the brass broiler orifice elbow, which is threaded into the broiler orifice holder on the back end of the broiler mixing tube.

To remove the the orifice, first remove the flue which covers the orifice holder. Disconnect the gas line from the brass elbow and unscrew the elbow from the orifice holder. Now, use wrenches to remove the orifice from the holder. (See Figure 3-37)

Spark Module Removal

NOTE: It is recommended to note and label the electrode/sparker wire locations before removing a spark module.

Begin removing a spark module by disconnecting all wire leads at the module. Then, extract the module mounting screws and pull the module from the bracket. (See Figure 3-37)

Fan Relay Removal

To remove a fan relay, first disconnect all wire leads at the relay. Then, extract the relay mounting screws and lift the relay from the bracket. (See Figure 3-37)

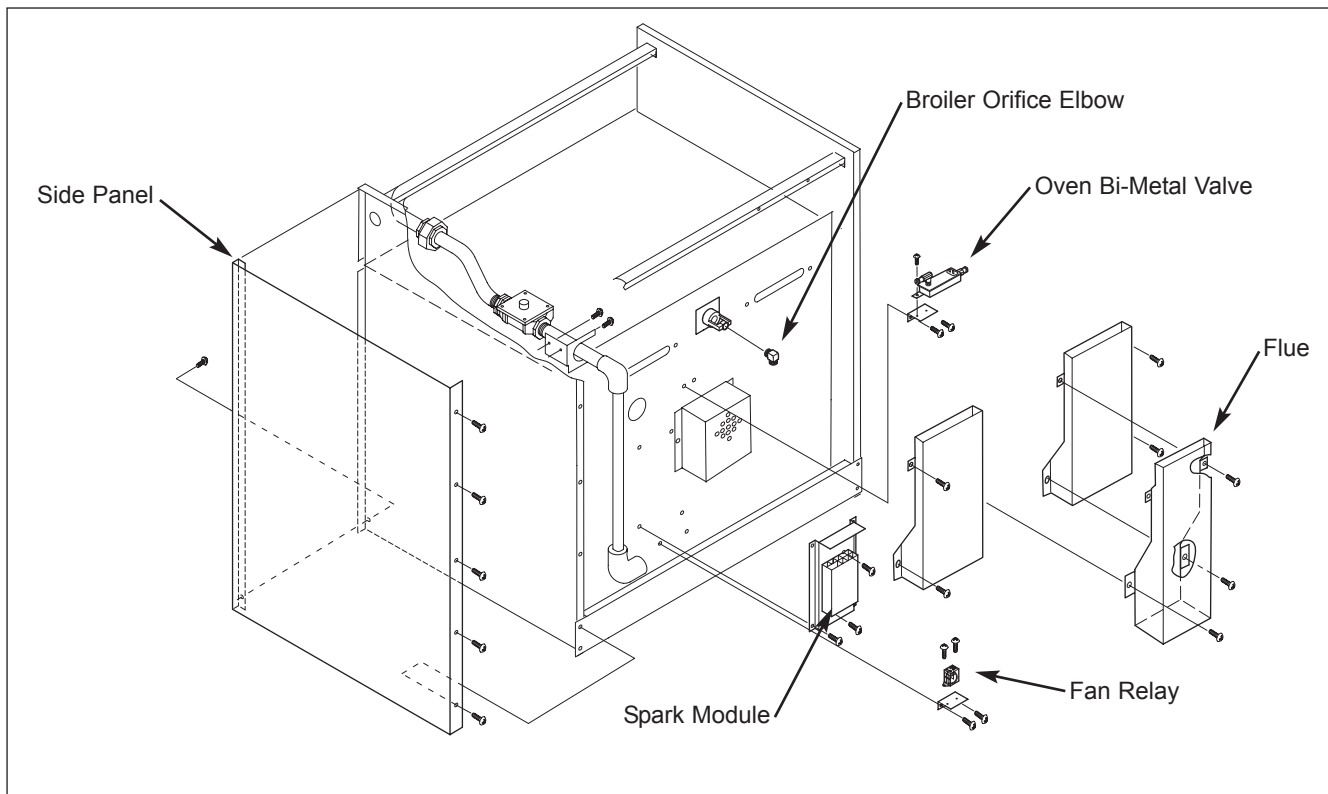

Figure 3-37. Side Panel and Components on Rear of Unit

SECTION 5

TROUBLESHOOTING GUIDE

TROUBLESHOOTING GUIDE

This section of the manual contains the General Troubleshooting Guide which will help the Service Technician troubleshoot a Wolf Range or Cooktop.

How to Use the Troubleshooting Guide

The troubleshooting guide table of contents shows how the troubleshooting guide is laid out. The troubleshooting guide is organized into component areas with the most common problems listed first.

On the table of contents below, identify the description of the problem that the unit is experiencing. To the left of the problem description is a letter. Locate that letter in the left column of the Troubleshooting Guide. The center column of the troubleshooting guide will identify the possible causes for the problem. The information to the right of the possible causes will explain what tests to perform in order to determine if what you are checking is the cause, and/or what action to take to correct the problem.

Troubleshooting Guide Table of Contents

	<i>page #</i>		<i>page #</i>
<u>Problems Associated with the Surface Burners</u>		<u>Problems Associated with the French Top</u>	
A. Constant sparking.....	6-3	S. Constant sparking.....	6-7
B. Intermittent Spark.....	6-3	T. Intermittent spark.....	6-7
C. Poor ignition	6-3	U. Poor ignition	6-8
D. No ignition.....	6-4	V. No ignition.....	6-8
E. Burner noise or whistle.....	6-4	W. Uneven Heat.....	6-8
F. Flame appearance.....	6-4	X. Not hot enough at center.....	6-8
1. Tall flame		Y. Too hot at front.....	6-8
2. Yellow flame			
3. Pulsing flames			
<u>Problems Associated with the Charbroiler</u>		<u>Problems Associated with the Oven Burner</u>	
G. Constant sparking.....	6-4	Z. Burner does not light.....	6-8
H. Intermittent spark.....	6-5	AA. Temperature to hot or cool for thermostat setting.....	6-8
I. Poor ignition.....	6-5	BB. Delayed ignition.....	6-9
J. No ignition.....	6-5	CC. Rushing noise from burner.....	6-9
K. Uneven Heat.....	6-5	DD. Yellow flames.....	6-9
L. Too hot.....	6-5		
<u>Problems Associated with the Griddle</u>		<u>Problems Associated with the Oven Broiler</u>	
M. Constant sparking.....	6-6	EE. Burner does not light.....	6-9
N. Intermittent spark.....	6-6	FF. Delayed ignition.....	6-10
O. Poor ignition	6-6	GG. Rushing noise from burner.....	6-10
P. No ignition.....	6-7		
Q. Uneven Heat.....	6-7	<u>Problems Associated with the Convection Fan</u>	
R. Cannot regulate temperatures.....	6-7	HH. Does not come on when switch is turned on.....	6-10
		II. Fan does not shut off when door is open.....	6-10
		<u>Problems Associated with the Oven Light</u>	
		JJ. No lights.....	6-10
		<u>Cosmetic</u>	
		KK. Surface burner rings turn rainbow colors.....	6-10
		LL. Riser is discolored or burned.....	6-10

PROBLEM	POSSIBLE CAUSE	TEST / ACTION
A. CONSTANT SPARKING AT SURFACE BURNERS	Burner base not properly positioned on burner body	Rotate to correct position and advise owner
	Electrode wired in wrong position at module	Check routing from wiring diagram for model
	Ground wire disconnected at outlet in wall	Have electrician repair
	Reverse Polarity at outlet power supply or power cord	May have to call an electrician. May have to properly wire the power cord to the unit.
	Defective micro switch at burner valve	Replace micro switch
	Arc at cut or splice in electrode wire	Replace electrode wire
	Cable ties on wire too tight	Cut tie and replace so wire is loose
	Defective spark module	Replace spark module
	Arcing at module to bracket or chassis	Check for break in insulation or missing fish paper shield
B. INTERMITTENT SPARKING AT SURFACE BURNERS	Dirty electrode	Clean with wire brush
	Cracked or damaged electrode	Replace electrode
	Electrode wired in wrong position at module	Check routing from wiring diagram for model
	Broken micro switch at burner valve	Replace micro-switch
	Electrode wires touching each other/metal	Separate and cover with sleeving
	Arc at cut or splice in electrode wire	Replace electrode wire
	Defective spark module	Replace spark module
	Bad connection at the molex connector on the spark module	Determine by continuity check
	Arcing at module to bracket or chassis	Check for break in insulation
C. POOR IGNITION AT SURFACE BURNERS	Outer burner ring not correctly placed on the burner base	Rotate to correct position and advise owner
	Burner base not properly positioned on burner body	Rotate to correct position and advise owner
	Burner base may be binding on pressed steel top and lifting	Check to see that there is an even concentric clearance between the burner base and the pressed steel top. The burner support may have to be repositioned
	Partially plugged holes or slots in the burner head	Clear as necessary
	Improper Gas orifice	Check orifice stamp number
	Gas pressure	Check for type gas and check gas pressure with a manometer

PROBLEM	POSSIBLE CAUSE	TEST / ACTION
D. NO IGNITION AT SURFACE BURNERS	Defective micro-switch at burner valve	Replace micro switch
	Defective or loose wiring	Replace/repair wiring
	Defective spark module or short to unit chassis	Replace spark module
	No Power	Check outlet and circuit breaker
	No gas to unit	Check gas pressure with a manometer
E. SURFACE BURNER NOISE OR WHISTLE	Air shutter or venturi out of adjustment	Adjust air shutter or venturi
	Check for proper orifice sizes	Check orifice stamp number
	Gas pressure	Check for type gas and check gas pressure with a manometer
F. FLAME APPEARANCE ON SURFACE BURNER 1. <i>Tall flame</i> 2. <i>Yellow flame</i> 3. <i>Flames pulsing</i>	Burner outer ring and burner base not positioned properly	Reposition rings
	Air shutter or venturi needs adjustment	Adjust air shutter or venturi
	By-products of combustion are affecting primary or secondary air	Make sure flue boxes are secure and seal is intact around IR broiler venturi tube
	Incorrect gas orifices	Check stamp number on orifices
	Gas pressure	Check gas pressure using a manometer
	Orifice holes in burner rings not to specification	Replace burner rings
G. CONSTANT SPARKING AT CHARBROILER	Sparker wire wired in wrong position at spark module	Check routing from wiring diagram for model
	Ground wire disconnected at outlet or on power cord to junction box	May have to call an electrician
	Reverse polarity at outlet, power supply or power cord	May have to call an electrician. may have to properly wire power cord to unit
	Defective micro switch at burner valve	Replace micro switch
	Cable ties on wire too tight	Cut tie and replace so wire is loose
	Defective spark module	Replace spark module
	Arcing at spark module to bracket or unit chassis	Check for break in insulation or missing

PROBLEM	POSSIBLE CAUSE	TEST / ACTION
H. INTERMITTENT SPARKING AT CHARBROILER	Dirty sparker	Clean food debris from sparker
	Cracked or damaged sparker	Replace sparker
	Sparkers wire wired in wrong position at spark module	Check routing from wiring diagram for model
	Defective micro switch at burner valve	Replace micro switch
	Sparkers wires touching each other or metal	Separate and cover with sleeving
	Arc at cut or splice in sparker	Replace sparker
	Bad connection at the molex connector on the spark module	Determine by continuity check. Repair/replace molex connector.
	Defective spark module	Replace spark module
I. POOR IGNITION AT CHARBROILER	Cracked or damaged sparker	Replace sparker
	Sparkers not arcing to ground strap close enough to tile surface	The strap and sparker should be clear of the screen and 1/32" above the tile
	Partially plugged holes in the burner tile	Clear as necessary with wire like paper clip. Replace burner if too many burner holes are clogged.
	Wrong orifice size	Check orifice stamp number
	Blockages in mixer tube or orifice	Clear or clean as necessary
	Gas pressure	Check gas pressure using a manometer
	Bent orifice bracket holder	Straighten so that gas jet is aimed straight down mixer tube or replace bracket holder
J. NO IGNITION AT CHARBROILER	Defective micro switch	Replace micro switch
	Loose or bad wire connection	Check all wires per wiring diagram
	Defective sparker	Replace sparker
	Defective spark module	Replace spark module
	No power	Check outlet and circuit breaker
	No gas	Check gas pressure using manometer
	Short to spark module bracket unit chassis	Visually inspect the spark module bracket
K. UNEVEN HEAT AT CHARBROILER	Unit not level	Level unit from front to rear and side to side
L. CHARBROILER TOO HOT	Needs blank off plate	Place blank-off plate on ceramic tiles per owner manual instruction

PROBLEM	POSSIBLE CAUSE	TEST / ACTION
M. CONSTANT SPARKING AT GRIDDLE	Sparker wired in wrong position at spark module	Check routing from wiring diagram for model
	Ground wire disconnected at outlet in wall or power cord to unit junction box	May have to call an electrician
	Reverse polarity at outlet, power supply or power cord	May have to call an electrician. May have to properly wire the power cord.
	Defective solenoid assembly	Replace solenoid assembly
	Defective thermostat	Replace thermostat
	Arc at cut or splice in sparker wire	Replace sparker
	Cable ties on wire too tight	Cut tie and replace the wire tie
	Defective spark module	Replace spark module
	Arcing at spark module to bracket or unit chassis	Check for break in insulation or missing fish paper shield
N. INTERMITTENT SPARKING AT GRIDDLE	Cracked or damaged sparker	Replace sparker
	Sparker wired in wrong position at spark module	Check routing from wiring diagram for model
	Sparker wires touching each other or metal	Separate and cover with sleeving
	Arc at cut or splice in sparker wire	Replace sparker
	Bad connection at the molex connector on the spark module	Determine by continuity check. Repair/replace molex connector.
	Defective thermostat	Replace thermostat
	Defective spark module	Replace spark module
O. POOR IGNITION AT GRIDDLE	Cracked or damaged sparker	Replace sparker
	Sparker not acing to ground strap close enough to tile surface	The strap and sparker should be clear of the screen and 1/32" above the tile
	Partially plugged holes in the burner tile	Clear as necessary with wire paper clip. Replace burner if too many burner holes are clogged.
	Wrong orifice size	Check orifice stamp number
	Gas pressure	Check gas pressure with a manometer
	Blockages in mixer tube or orifice	Clear or clean as necessary
	Bent orifice bracket holder	Straighten bracket holder so gas jet is aimed straight down mixing tube or replace bracket holder

PROBLEM	POSSIBLE CAUSE	TEST / ACTION
P. NO IGNITION AT GRIDDLE	Defective sparker	Replace sparker
	Defective solenoid or valve	Replace solenoid or valve
	Loose wire connection	Check all wires per wiring diagram
	Defective spark module	Replace spark module
	Defective thermostat	Replace thermostat
	Short at spark module bracket or unit chassis	Visually inspect the spark module or bracket for damage
	No gas	Check gas pressure with a manometer
Q. UNEVEN HEAT AT GRIDDLE	Unit not level	Level unit from front to rear and side to side
R. CANNOT REGULATE TEMPERATURE AT GRIDDLE	Kinked or pinched capillary tube on the thermostat	Straighten capillary tube or replace thermostat.
	Thermostat bulb not installed properly	Install thermostat bulb properly
	Defective thermostat	Replace thermostat
S. CONSTANT SPARKING AT FRENCH TOP	Electrode wired in wrong position at module	Check routing from wiring diagram for model
	Ground wire disconnected at outlet in wall or unit junction box	May have to call an electrician.
	Reverse polarity at outlet, power supply or power cord	May have to call an electrician. May have to properly wire the power cord to the unit.
	Cracked or defective electrode	Replace electrode
	Defective micro switch at burner valve	Replace micro switch
	Arc at cut or splice in electrode wire	Replace electrode wire
	Cable ties on wire too tight	Cut tie and replace so wire is loose
	Defective spark module	Replace spark module
	Arcing at spark module to bracket or unit chassis	Visually inspect the spark module or bracket for damage.
T. INTERMITTENT SPARKING AT FRENCH TOP	Cracked or defective electrode	Replace electrode
	Electrode wired in wrong position at module	Check routing from wiring diagram for model
	Arc at cut or splice in electrode wire	Replace electrode wire
	Electrode wires touching each other or metal	Separate cover with sleeving
	Bad connection at molex connector on spark module	Determine by continuity check. Repair/replace molex connector.
	Broken micro switch at burner valve	Replace micro switch
	Defective spark module	Replace spark module

PROBLEM	POSSIBLE CAUSE	TEST / ACTION
U. POOR IGNITION AT FRENCH TOP	Burner head not in position	Locate per owner's manual and advise owner
	Partially plugged holes in the burner head	Clear as necessary
	Cracked or damaged electrode or wiring	Replace electrode or wiring
	Check for proper orifice size	Check orifice number stamped on orifice
	Gas pressure	Check gas pressure with a manometer
V. NO IGNITION AT FRENCH TOP	Loose wire connection	Check per wiring diagram
	Defective electrode	Replace electrode
	Defective spark module	Replace spark module
	No power	Check outlet and circuit breaker
	No gas	Check gas pressure with a manometer
W. UNEVEN HEAT AT FRENCH TOP	Unit not level	Level unit from front to rear and side to side
X. NOT HOT ENOUGH AT CENTER OF FRENCH TOP	Flame ring missing	Place as shown in owner's manual and advise customer
Y. TOO HOT AT FRONT OF FRENCH TOP	Outer plate installed backwards	Turn outer plate in proper direction
Z. OVEN BURNER DOES NOT LIGHT	Defective glow coil igniter	Replace if not drawing 3.3 to 3.6 amps. See procedure in technical section
	Defective bi-metal valve	Replace if not drawing 3.03 to 3.3 VAC. See procedure in technical section
	Loose or broken connection between components	Check all connections per wiring diagram
	Defective thermostat	Check continuity at the thermostat and replace if defective.
	No power	Check outlet and circuit breaker
	No gas	Verify that there is gas to the appliance. You may have to also check bimetal valve. Also check shut-off valve on manifold to verify it is in open position.
AA. OVEN BURNER TEMPERATURE TOO HOT OR COOL FOR THERMOSTAT SETTING	Oven burner thermostat out of calibration	Calibrate oven burner thermostat (See instructions in Tech Data section of manual)

PROBLEM	POSSIBLE CAUSE	TEST / ACTION
BB. DELAYED IGNITION OF OVEN BURNER	Igniter bracket bent	Straighten and reposition or replace if necessary. Needs to be 90° with burner tube.
	Orifice bracket holder reversed	Reverse the bracket so the flange faces toward the back of the unit.
	Defective glow coil igniter	Replace if not drawing 3.3 to 3.6 amps. See procedure in technical section
	Bent orifice bracket holder	Straighten so that gas jet is aimed straight down venturi tube, replace if necessary.
	Defective bi-metal valve	Replace if not drawing 3.03 to 3.3 VAC. See procedure in technical section
	Kinked or pinched capillary tube on the thermostat	Straighten the capillary tube or replace the thermostat
	Defective thermostat	Replace thermostat
	Blockage in venturi or orifice	Clear as necessary
CC. RUSHING NOISE FROM OVEN BURNER	Orifice bracket holder reversed	Reverse the bracket so the flange faces toward the back of the unit.
	Bent orifice bracket holder	Straighten so that gas jet is aimed straight down venturi tube, replace if necessary.
	Oven burner tube pushed too far back	Pull burner tube forward so orifice is in burner tube.
	Air shutter out of adjustment	Adjust air shutter
DD. YELLOW FLAMES AT OVEN BURNER	Air shutter out of adjustment	Adjust air shutter
	Wrong or dirty orifice	Check orifice size and clean if necessary
EE. OVEN BROILER BURNER DOES NOT LIGHT	Defective glow coil igniter	Replace if not drawing 3.3 to 3.6 amps.
	Loose or broken connection between components	Check all connections per wiring diagram
	Defective bi-metal valve	Replace if not drawing 3.03 to 3.3 VAC.
	Defective thermostat	Check continuity at the thermostat and replace if defective.
	No power	Check outlet and circuit breaker
	No gas	Verify that there is gas to the appliance. You may have to also check bimetal valve. Also check shut-off valve on manifold to verify it is in open position.

PROBLEM	POSSIBLE CAUSE	TEST / ACTION
FF. DELAYED IGNITION OF OVEN BROILER	Igniter bracket bent	Straighten and position
	Defective glow coil igniter	Replace if not drawing 3.3 to 3.6 amps.
	Defective bi-metal valve	Replace if not drawing 3.03 to 3.3 VAC.
	Bent orifice bracket holder	Straighten so that gas jet is aimed straight down venturi tube, replace if necessary.
	Blockage in venturi or orifice	Clear as necessary
GG. RUSHING NOISE FROM OVEN BROILER BURNER	Bent orifice bracket holder	Straighten so that gas jet is aimed straight down venturi tube, replace if necessary.
	Back Lighting situation	Gas is burning between screens or in box. Broiler needs to be replaced
HH. CONVECTION FAN DOES NOT COME ON WHEN SWITCH IS TURNED ON	Oven broiler is on	Fan does not function during broil
	Loose connection	Check all components in circuit. See wiring diagram.
	Defective fan panel switch	Check for continuity and replace if defective
	Defective fan motor	Check for continuity and replace if defective
	Defective fan relay	Check for continuity and replace if defective
	No Power	Check outlet and circuit breaker
II. CONVECTION FAN DOES NOT SHUT OFF WHEN DOOR IS OPEN	Fan switch in "COOL" position	This is normal operation. Instruct customer
	Defective fan door switch	Check for continuity and replace if defective
	Defective fan relay	Check for continuity and replace if defective
	Defective fan panel switch	Check for continuity and replace if defective
JJ. PROBLEMS ASSOCIATED WITH THE OVEN LIGHT	Defective light bulb	Check light bulb and replace if necessary
	Loose or disconnected wire connection in the wiring circuit	Check for voltage at the light sockets
	Defective light panel switch	Check light circuit with wiring diagram
	Defective light socket	Check continuity of the light socket
	No power	Check outlet and circuit breaker
KK. SURFACE BURNER RINGS TURN RAINBOW COLORS	Discoloration from heat	This is normal after repeated use
LL. RISER IS DISCOLORED OR BURNED	Discoloration from heat, caused by flames licking out from large pots at rear burners.	This is normal. Always test cleaning solutions on a non conspicuous stainless steel spot before attempting to clean.

SECTION 6

TECHNICAL DATA

GAS PRESSURE		
Gas Supply Line Pressure	<i>Natural Gas and Liquid Propane Maximum</i>	14" WC
	<i>Natural Gas Minimum</i>	7" WC
	<i>Liquid Propane Minimum</i>	11" WC
Natural Gas Manifold Pressure, with Standard Orifice		5" WC
Liquid Propane Manifold Pressure, with Standard Orifice		10" WC

ORIFICE CHART							
Natural Gas 5" WC				Liquid Propane Gas 10" WC			
Description	BTU	Stamp No.	Part No.	Description	BTU	Stamp No.	Part No.
Valve, Burner	16,000			Valve, Burner	16,000		
Orifice, Inner Bypass		*40	800892	Orifice, Inner Bypass		*25	800055
Orifice, Outer Bypass		*88	800884	Orifice, Outer Bypass		*54	800054
Burner, Body Assy	16,000			Burner Body Assy	16,000		
Orifice, Inner		*34	800882	Orifice, Inner		*7	800052
Orifice, Outer		*170	800872	Orifice, Outer		*109	800875
Burner, Charbroiler	16,000			Burner, Charbroiler	16,000		
Orifice		*50	800048	Orifice		*56	800050
Burner, Griddle	18,000			Burner, Griddle	18,000		
Orifice		*46	800047	Orifice		*55	800049
Burner, Oven Broil	18,000			Burner, Oven Broil	18,000		
Orifice		*48	800259	Orifice		*56	800057
French Top	15,000			French Top	15,000		
Orifice		*170	800060	Orifice		*117	800061
Burner, Oven Tube	30,000			Burner, Oven Tube	30,000		
Large Oven Orifice		*36	800071	Large Oven Orifice		*1.65	800059
Burner, Oven Tube	18,000			Burner, Oven Tube	18,000		
Small Oven Orifice		*48	800073	Small Oven Orifice		*55	800058

* *Standard Orifice Size Supplied with Unit*

CHECKING OVEN IGNITION SYSTEM

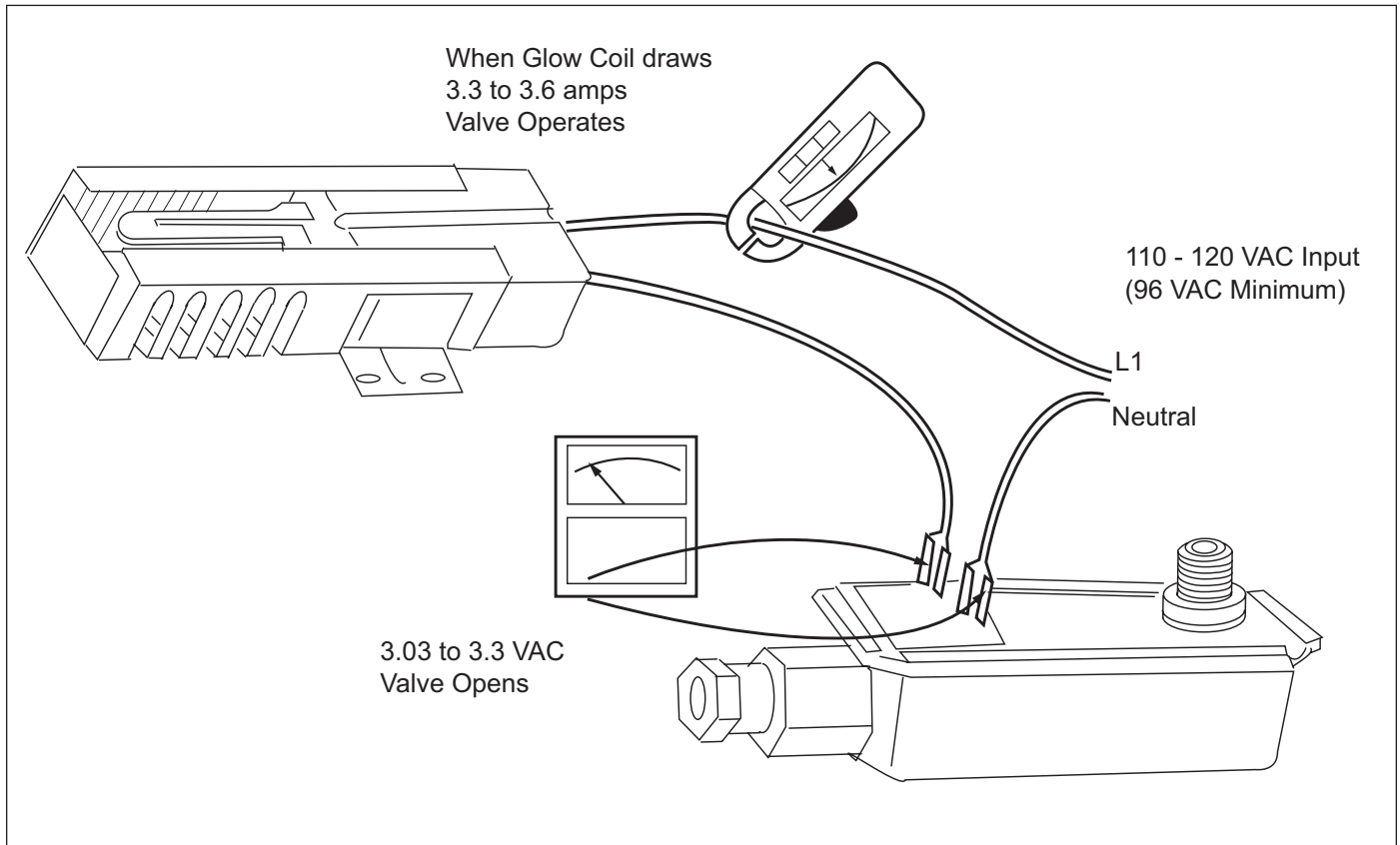

SECTION

N 7

WIRING

DIAGRAMS

R304/R304-LP

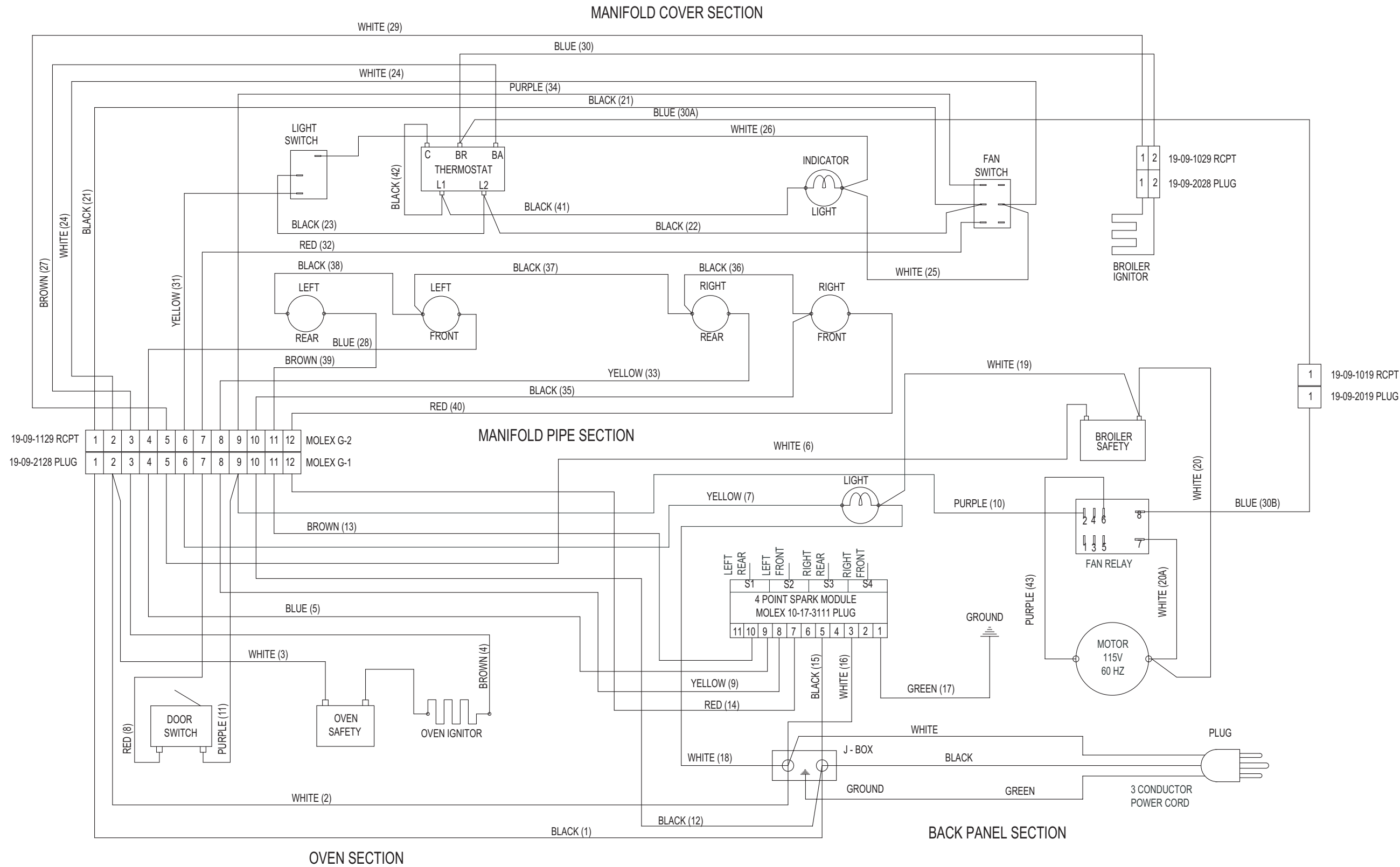

R366/R366-LP

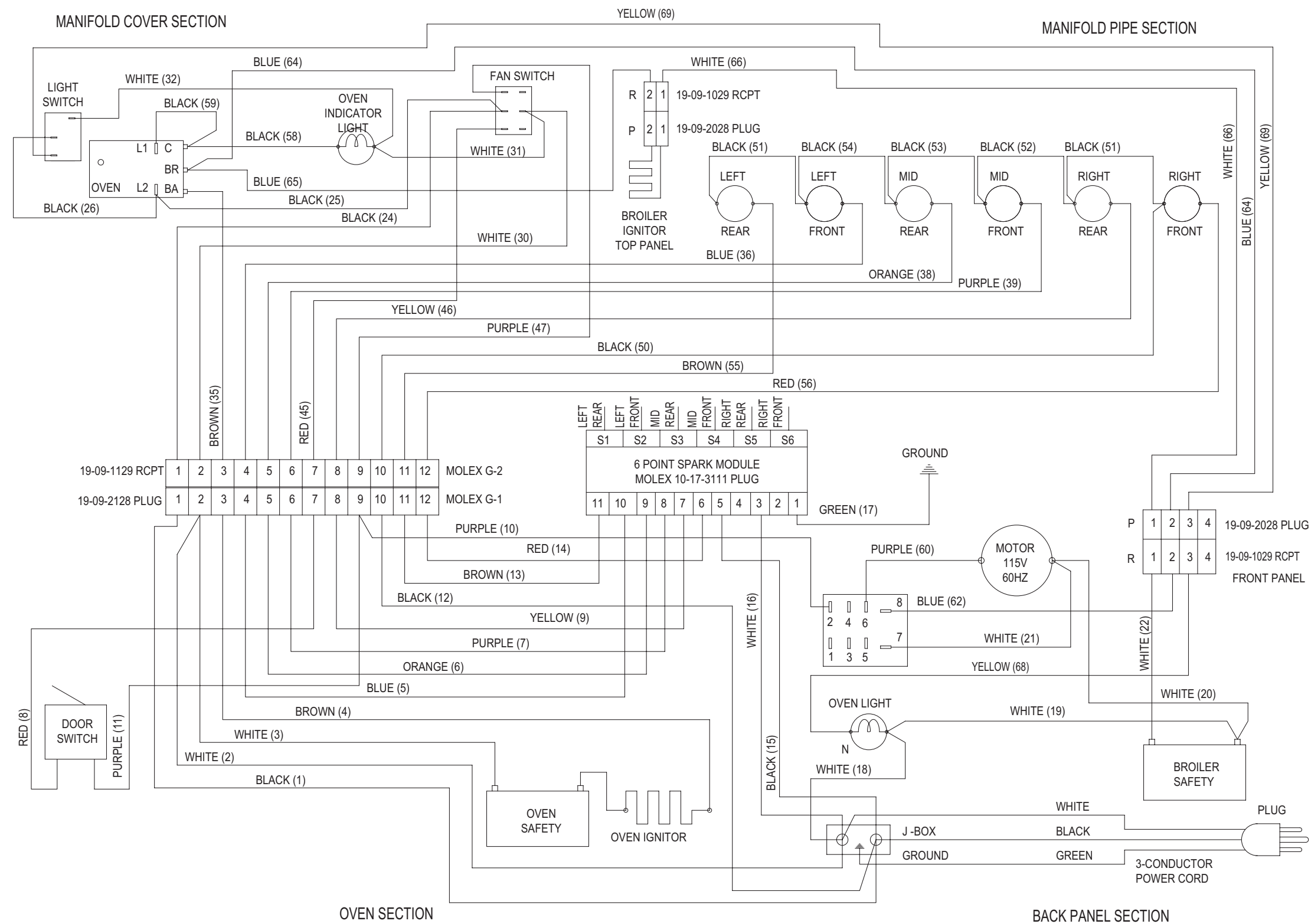

R364C/R364C-LP

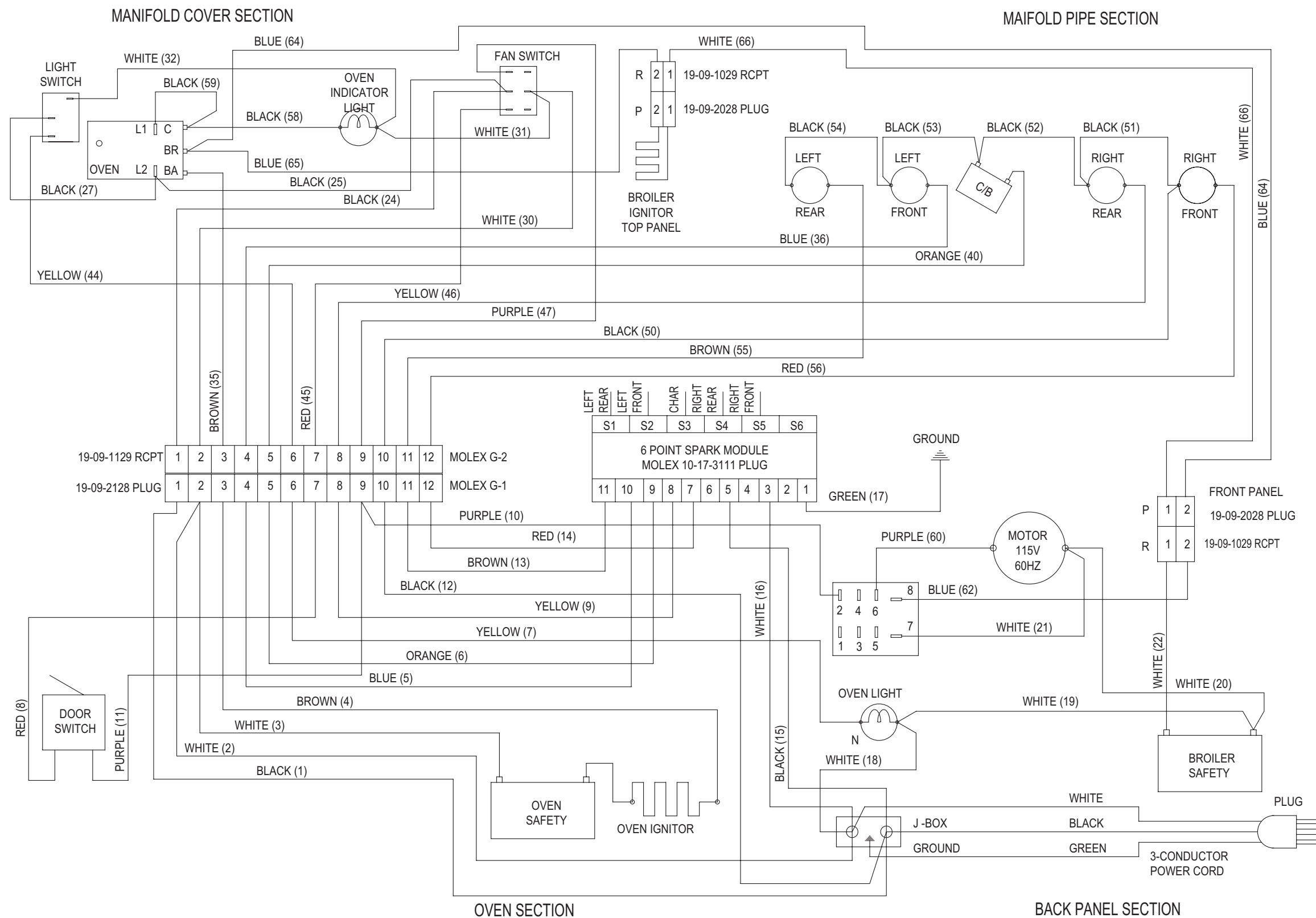

R364G/R364G-LP

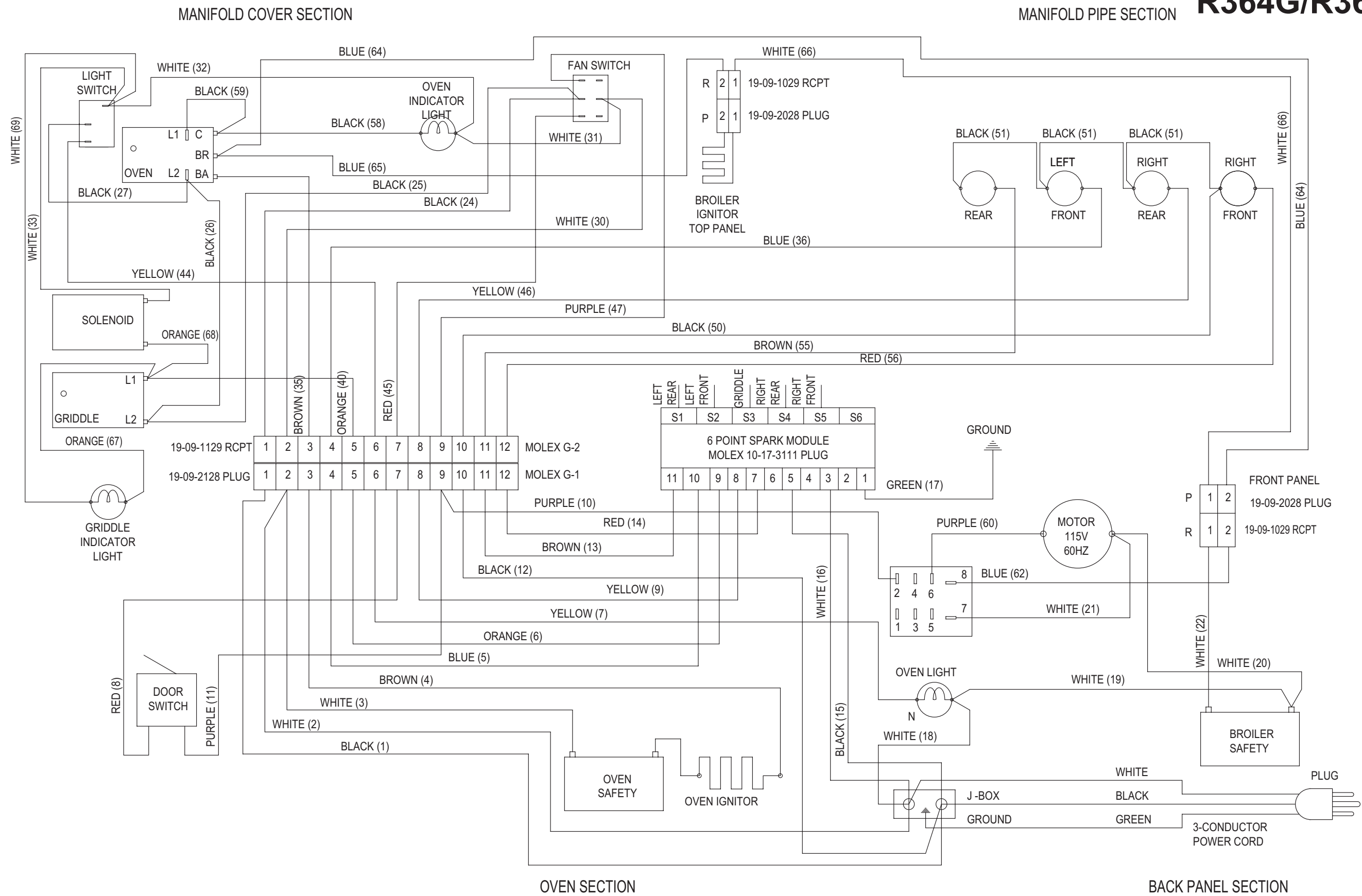

R488/R488-LP

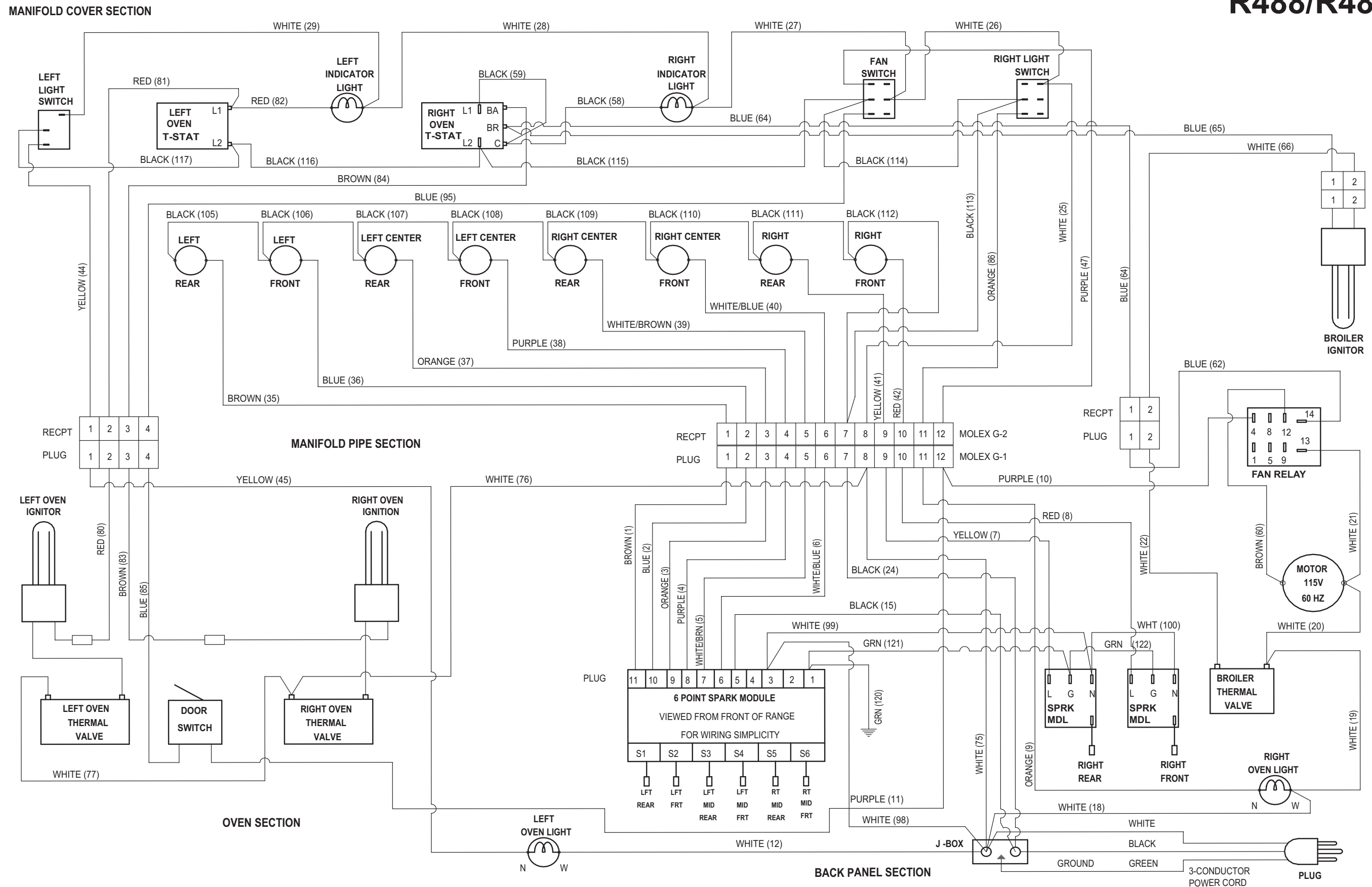

R486C/R486C-LP

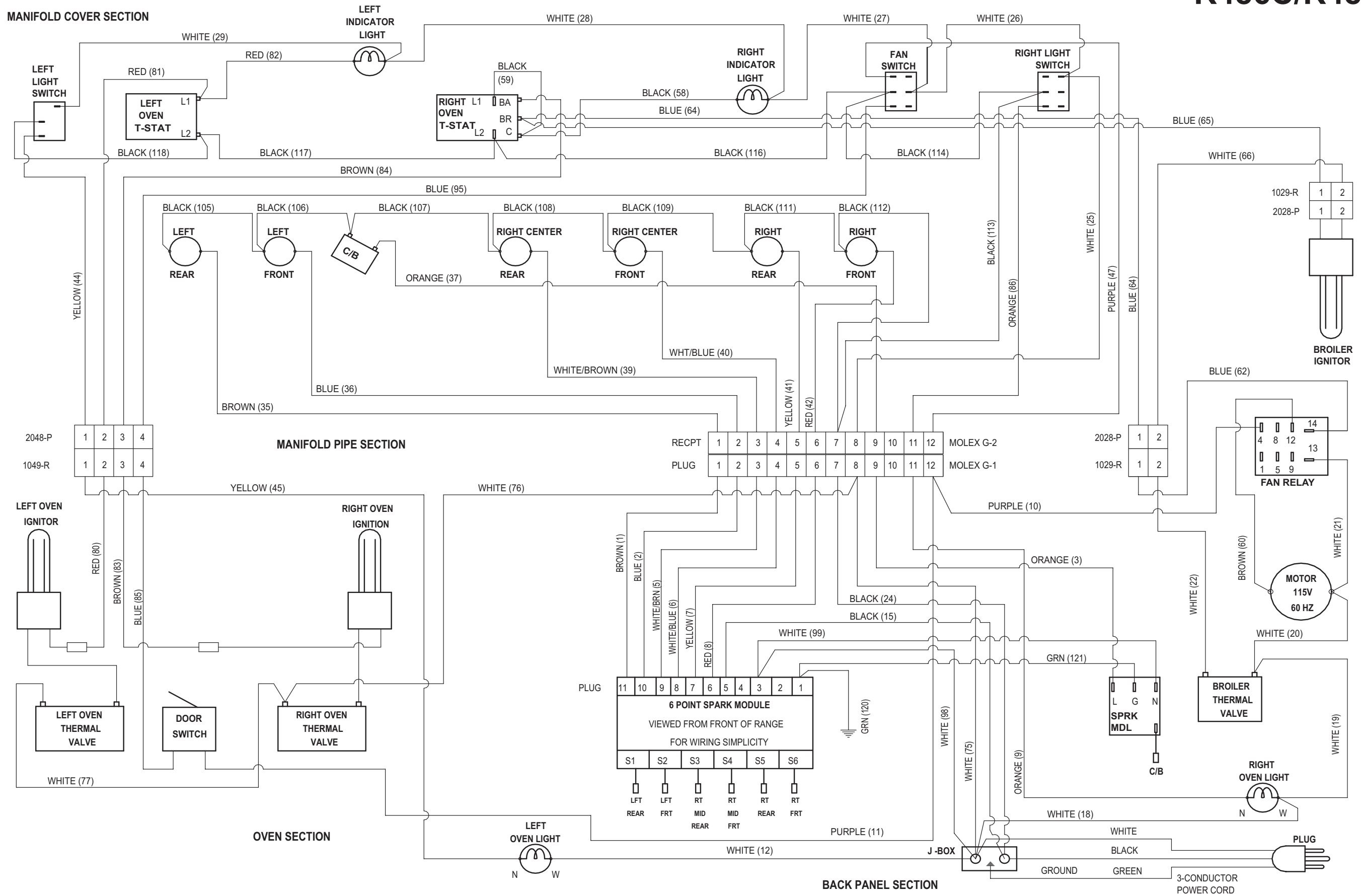

R486G/R486G-LP

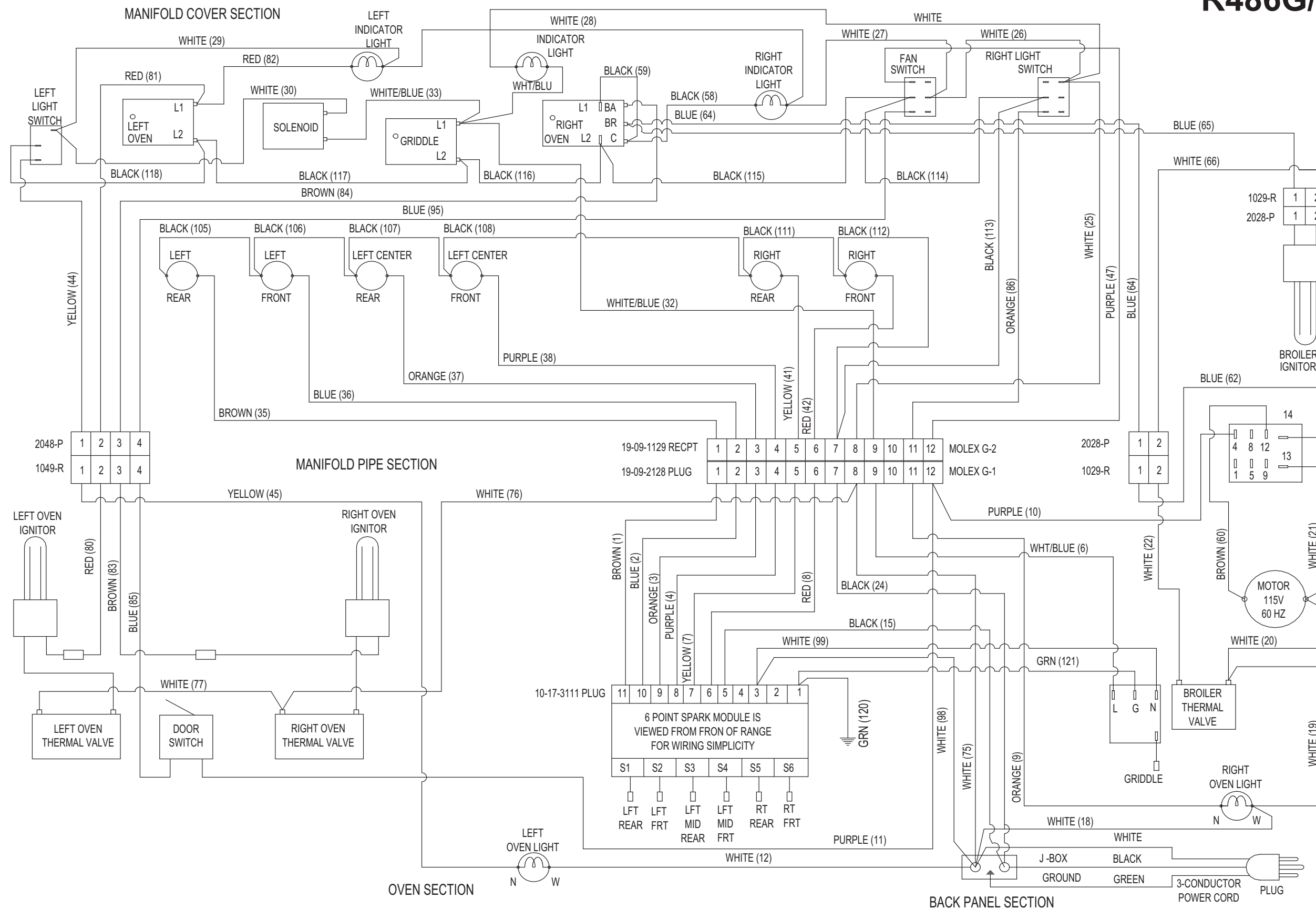

R484CG/R484CG-LP

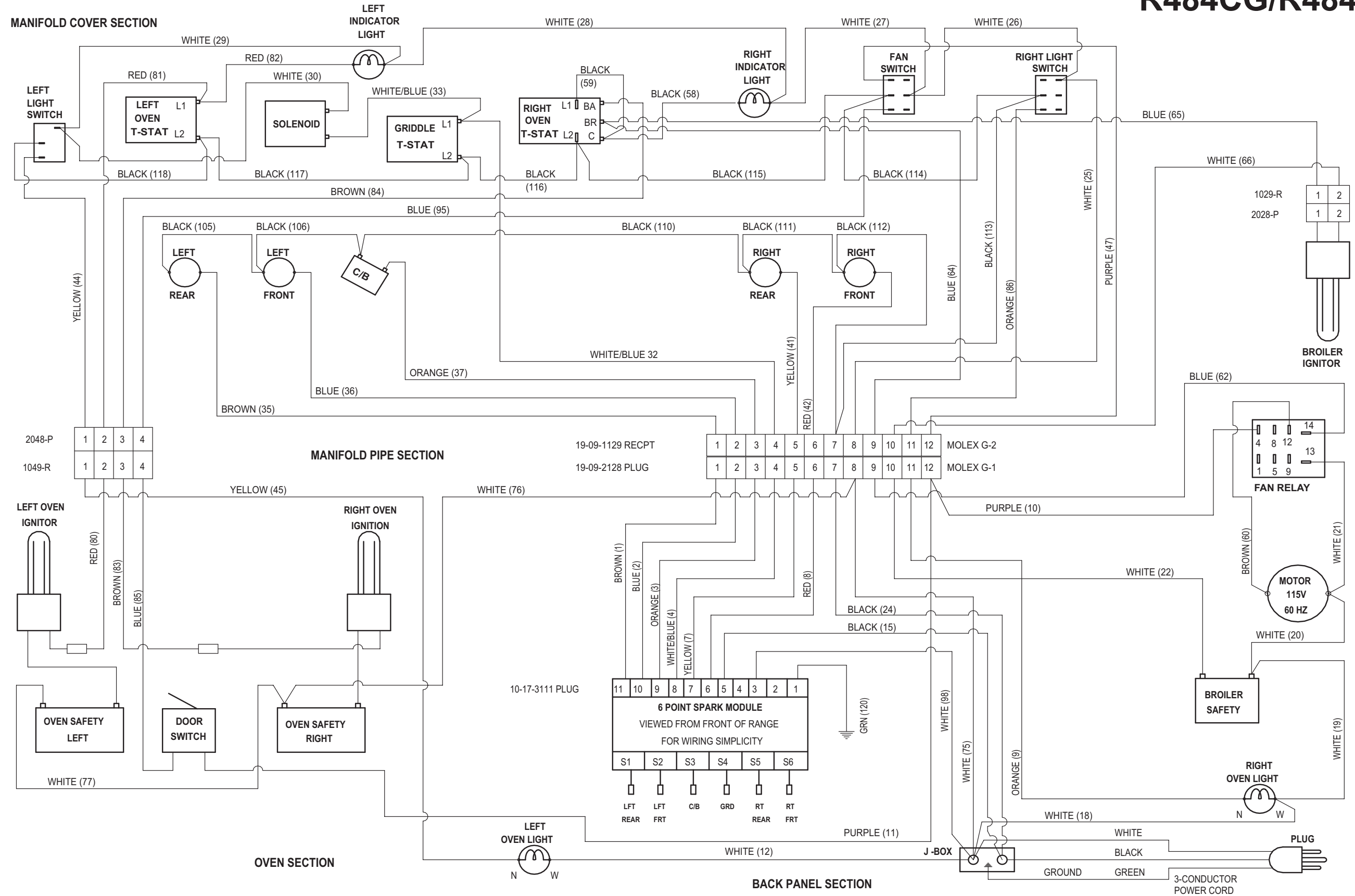

R484DC/R484DC-LP

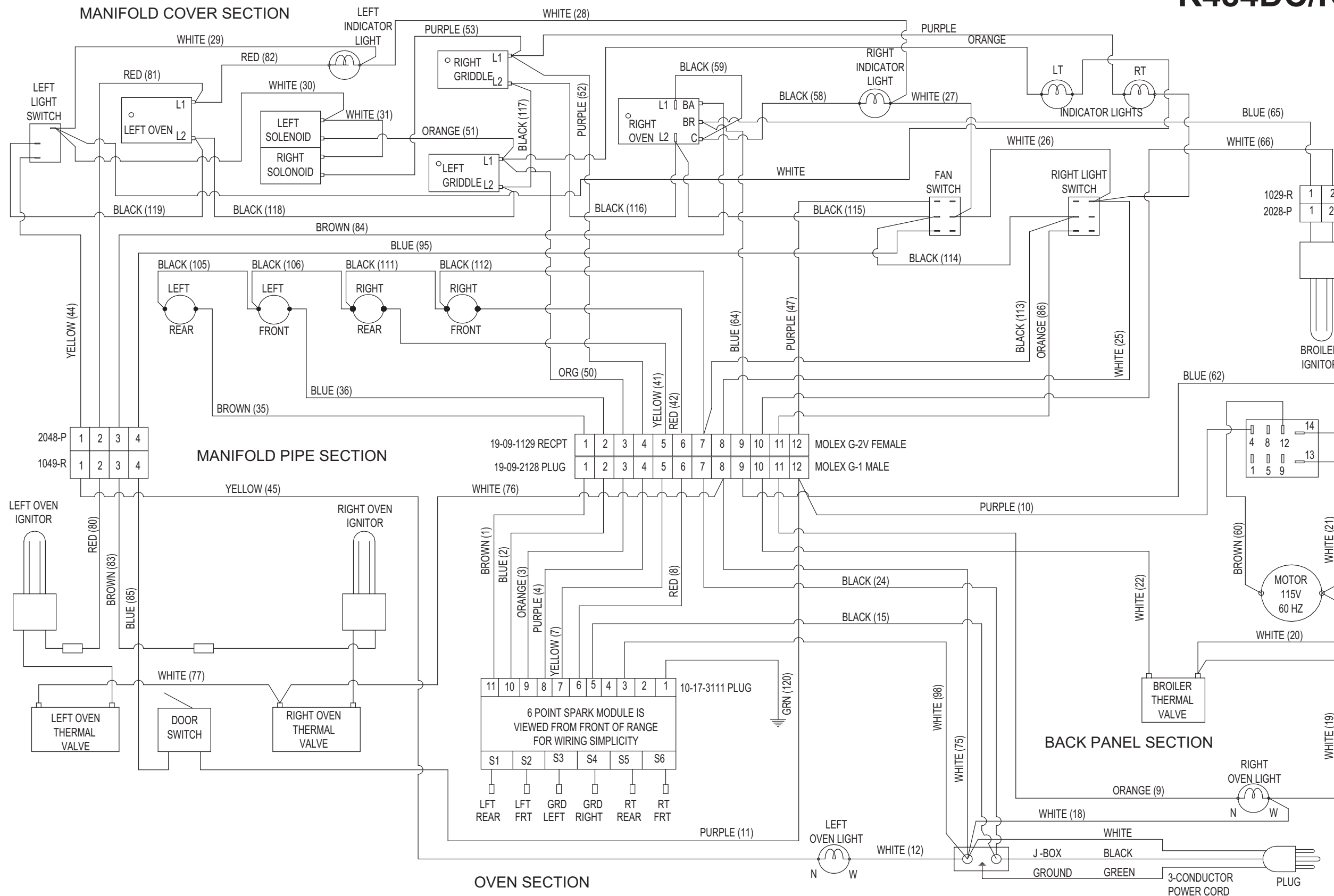

R484DG/R484DG-LP

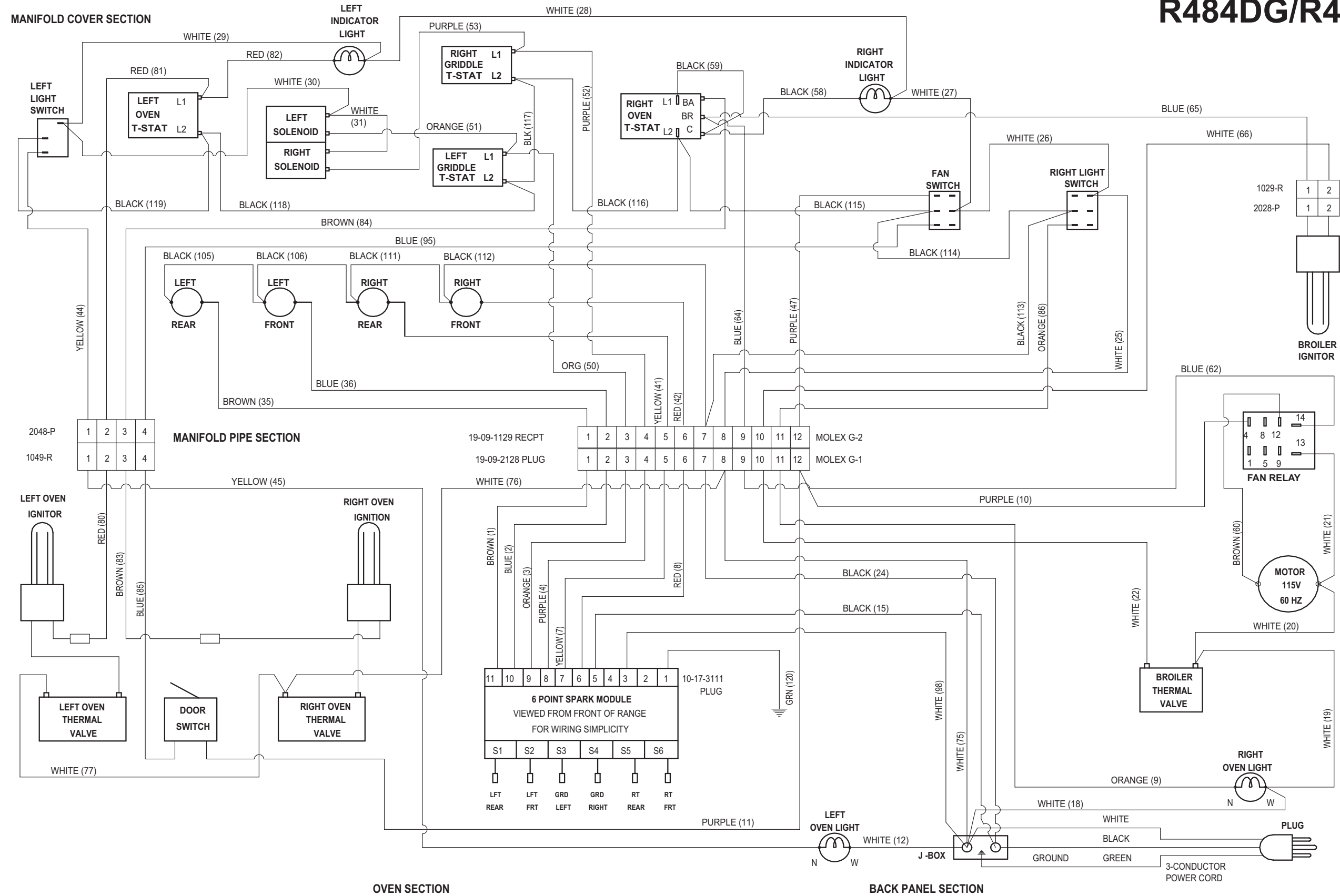

R484F/R484F-LP

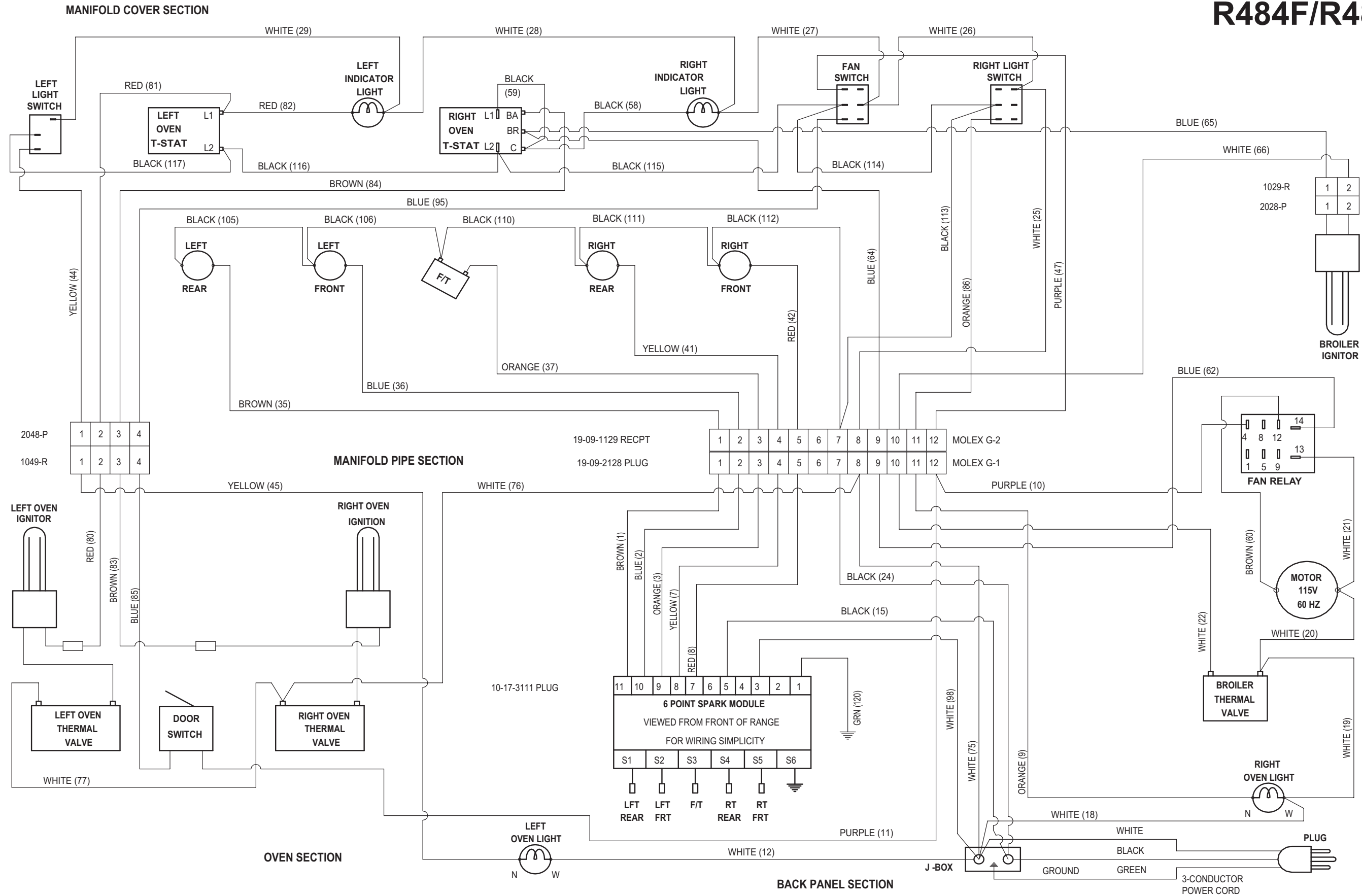

R482CF/R482CF-LP

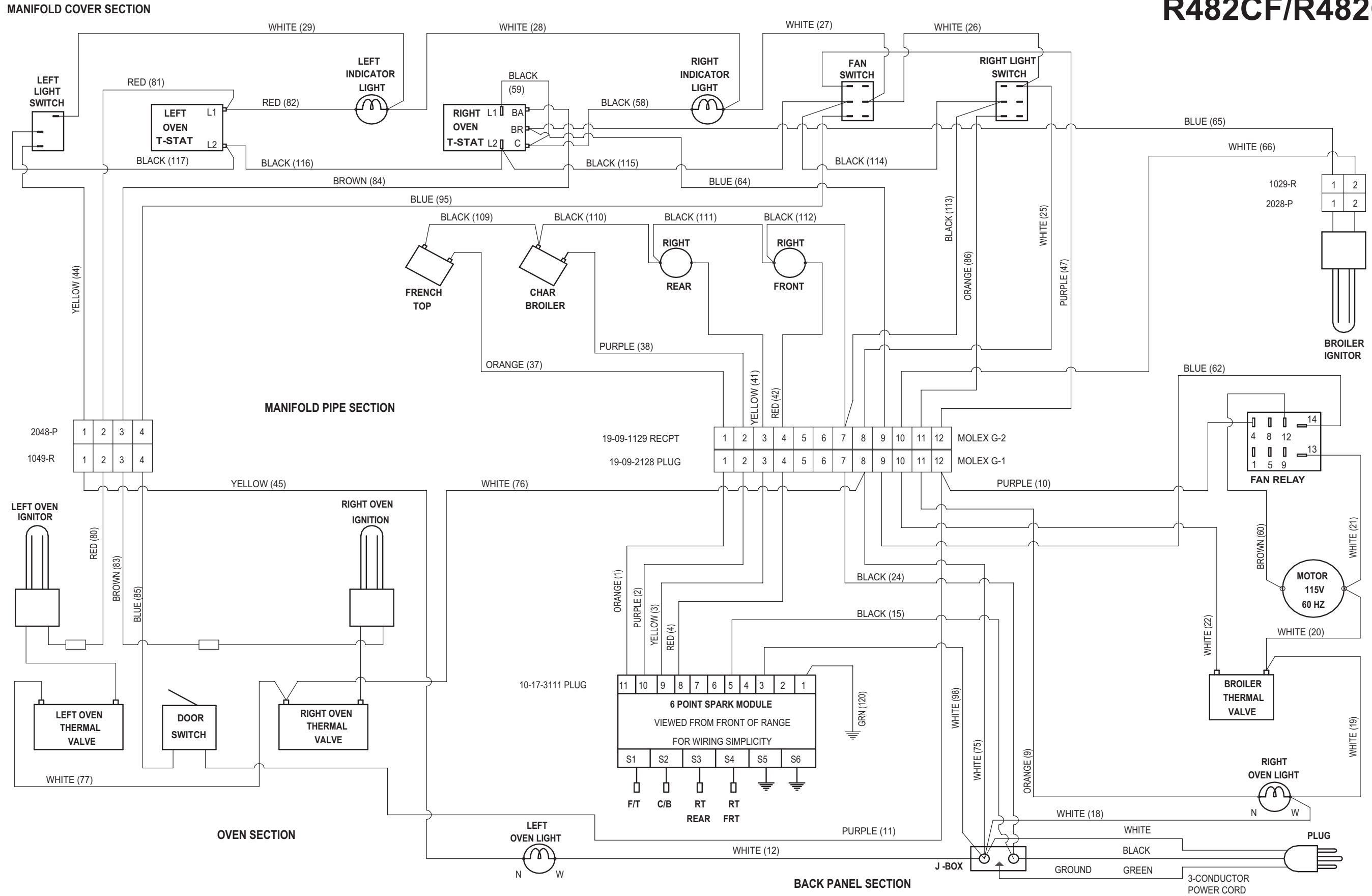

R606DC/R606DC-LP

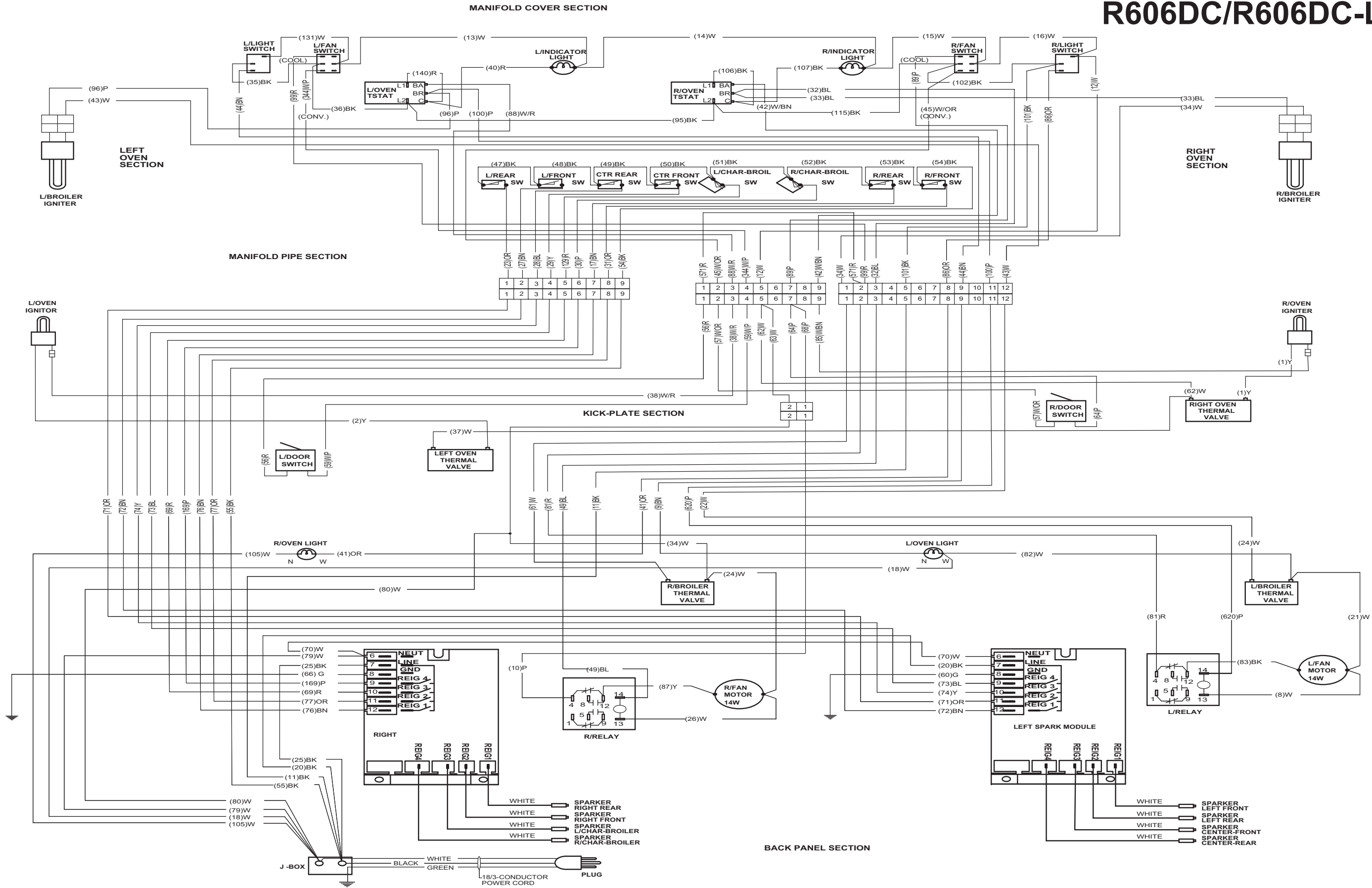

R606DG/R606DG-LP

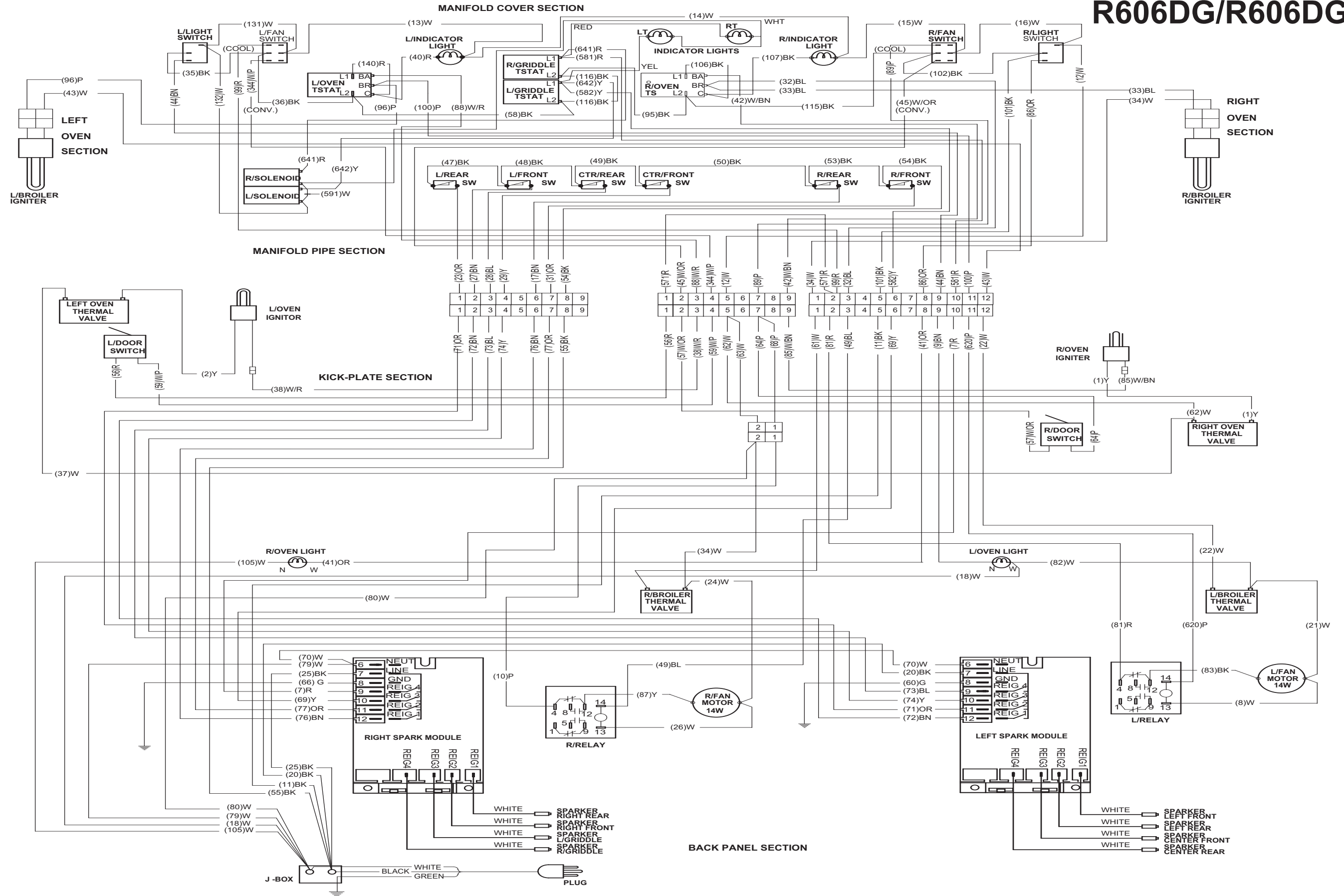

R606F/R606F-LP

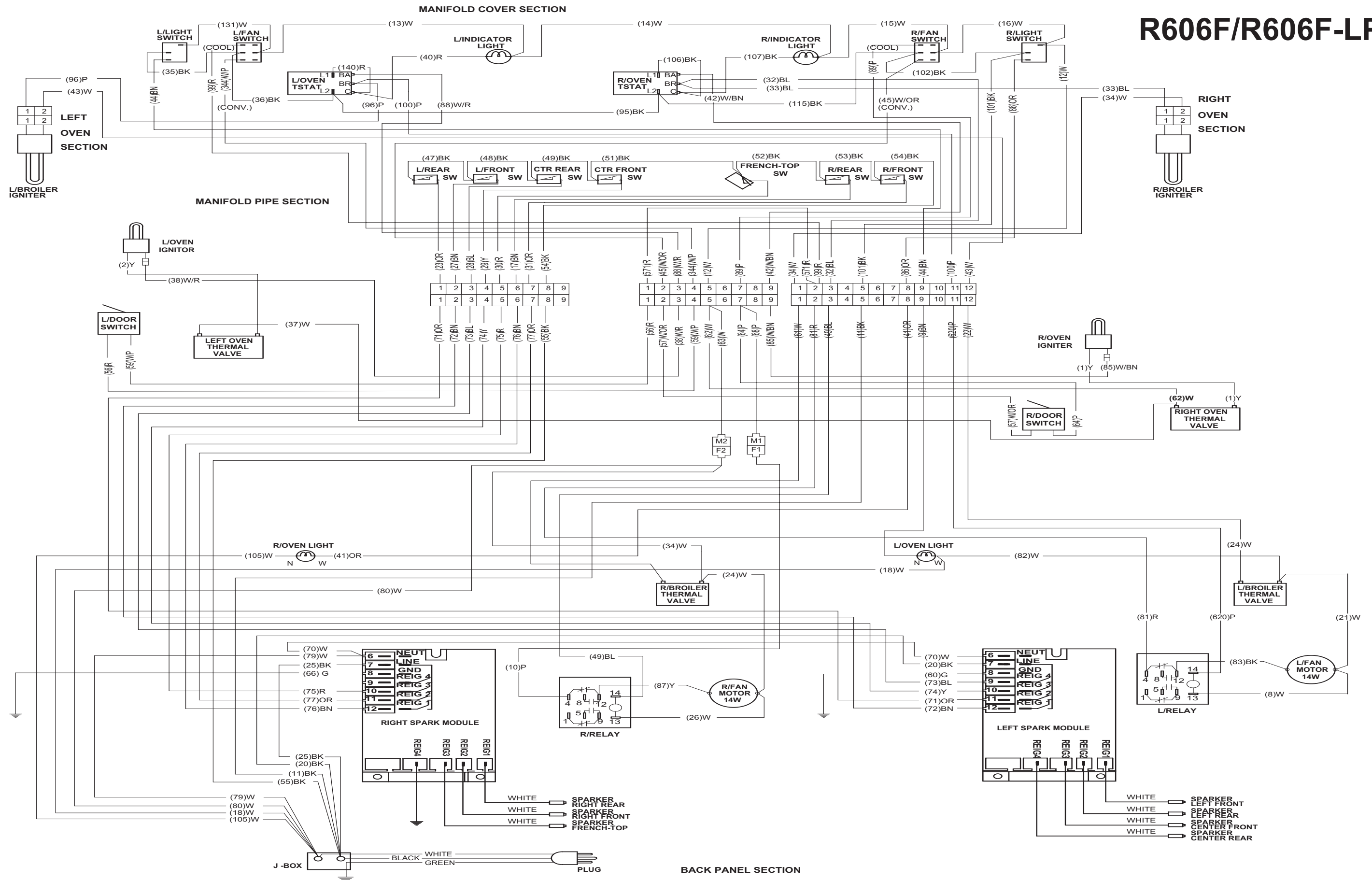

R606CG/R606CG-LP

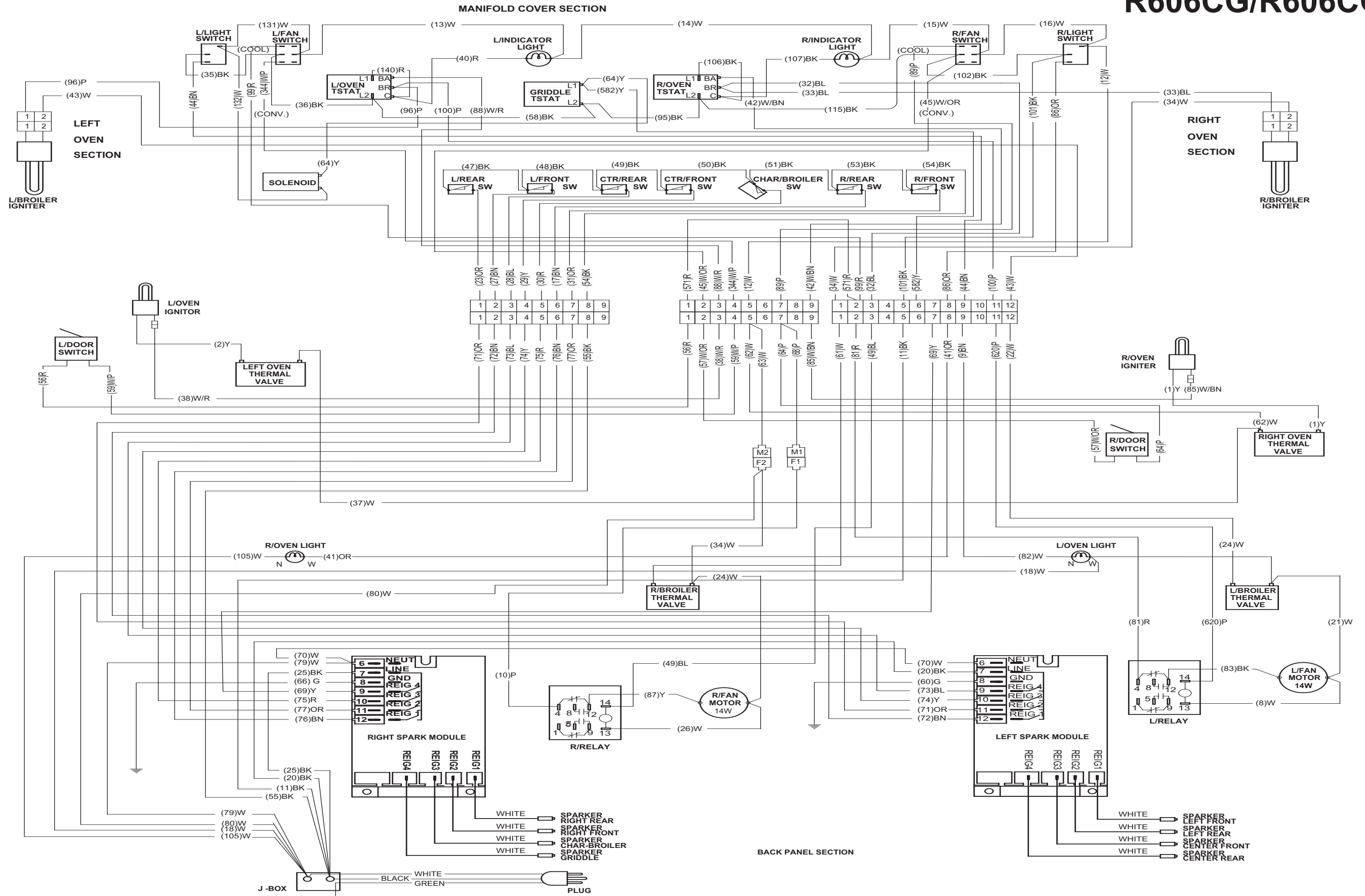

R604CF/R604CF-LP

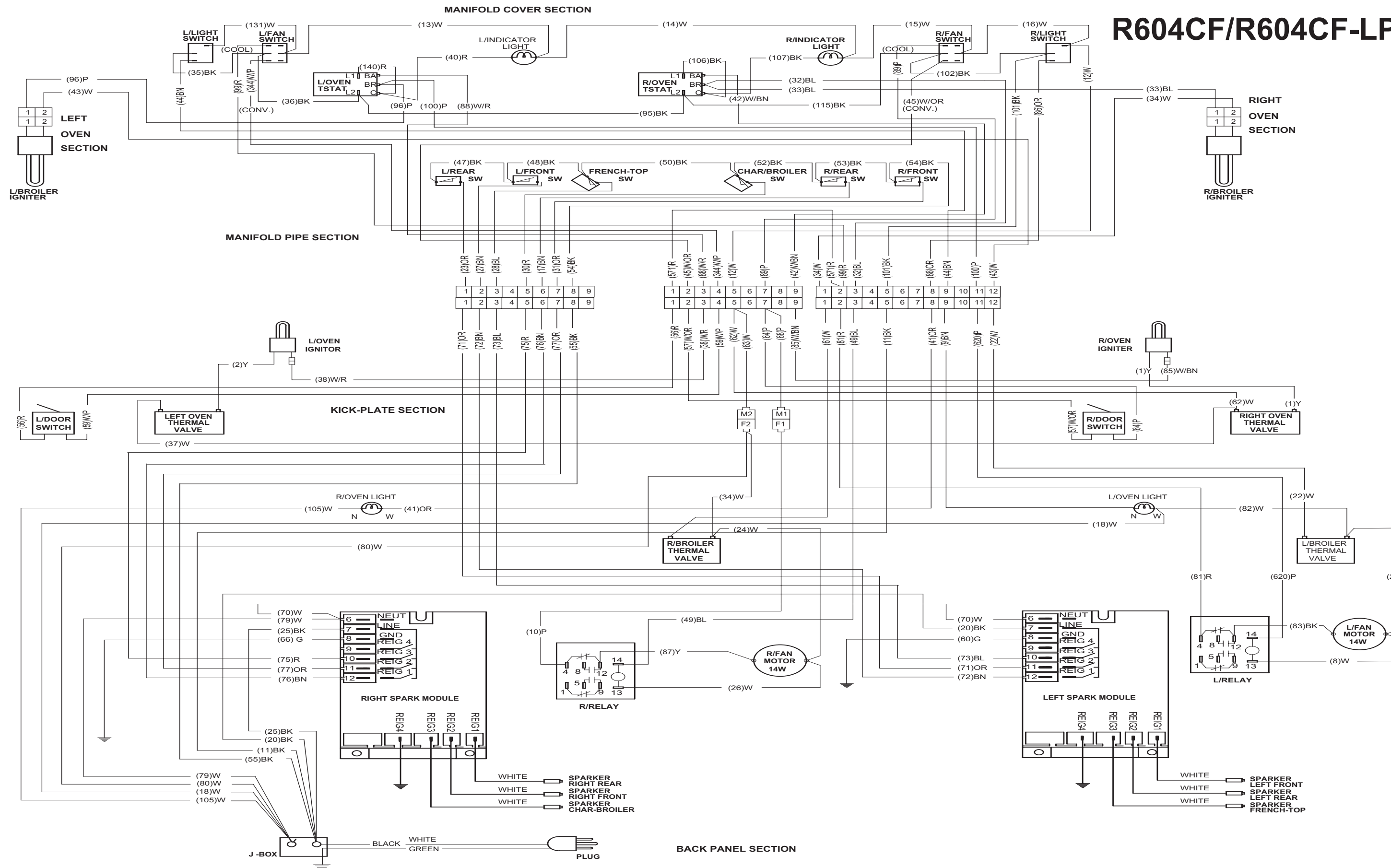

R604GF/R604GF-LP

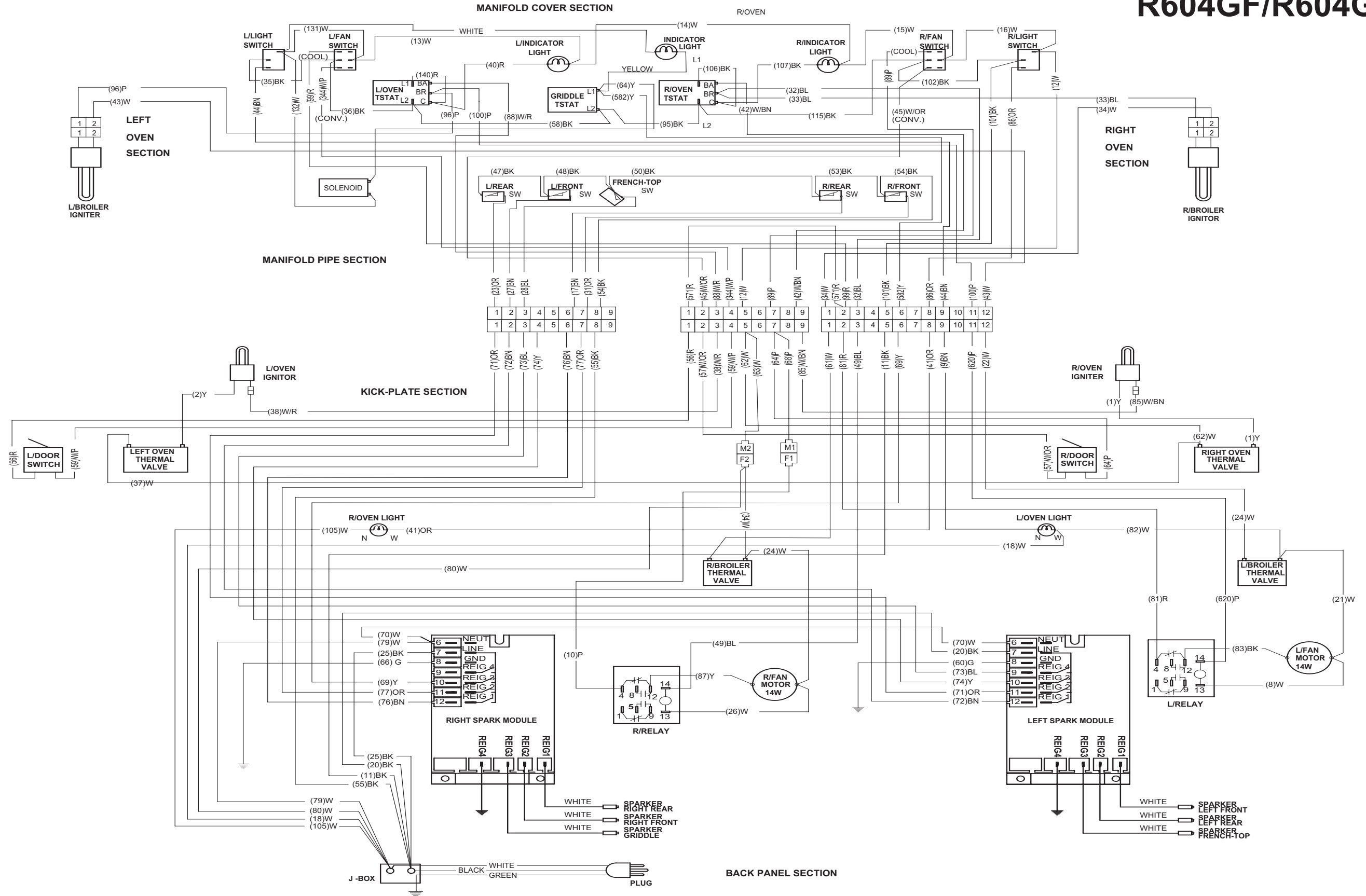

RT366/RT366-LP

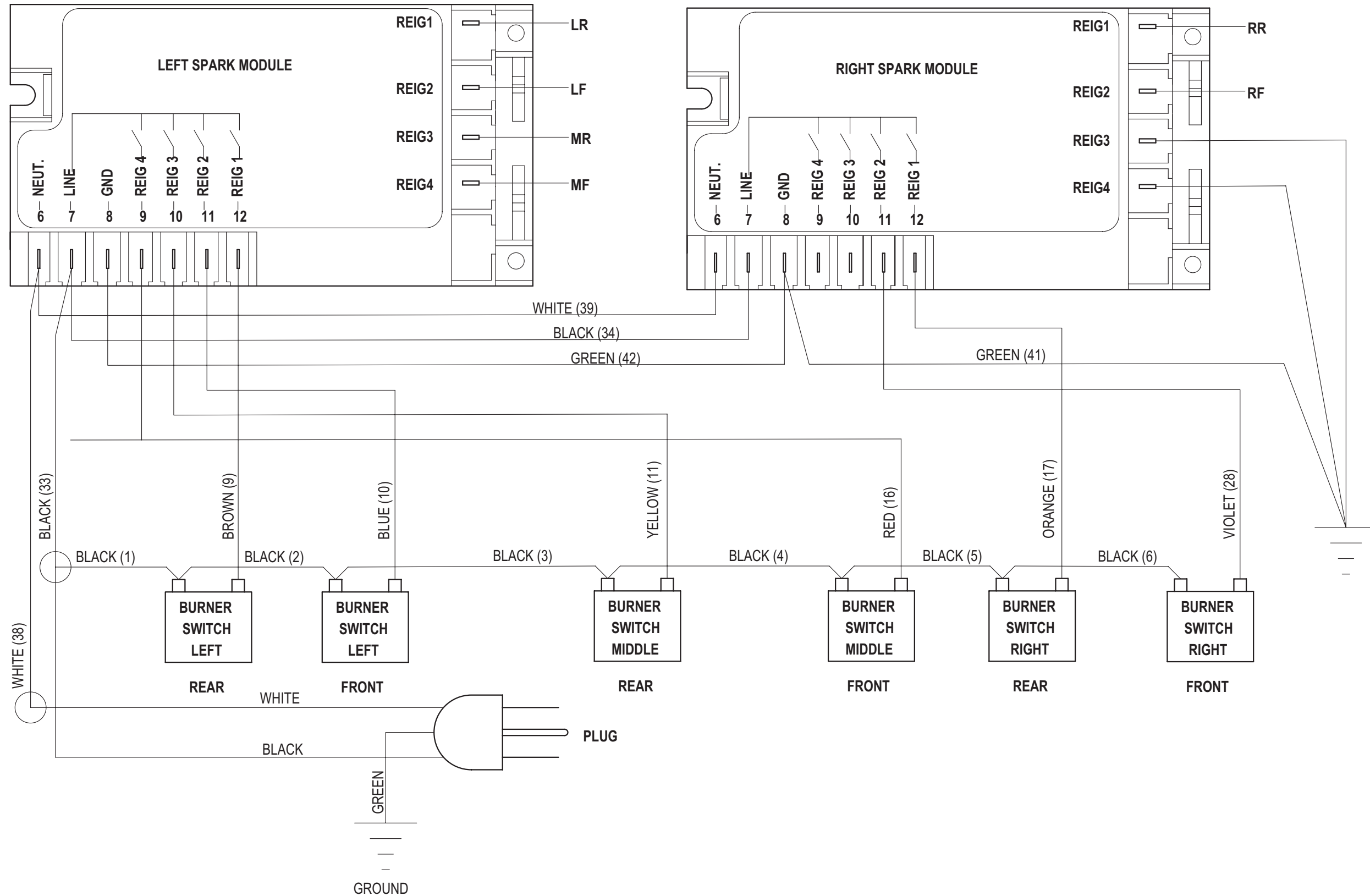

RT364C/RT364-LP

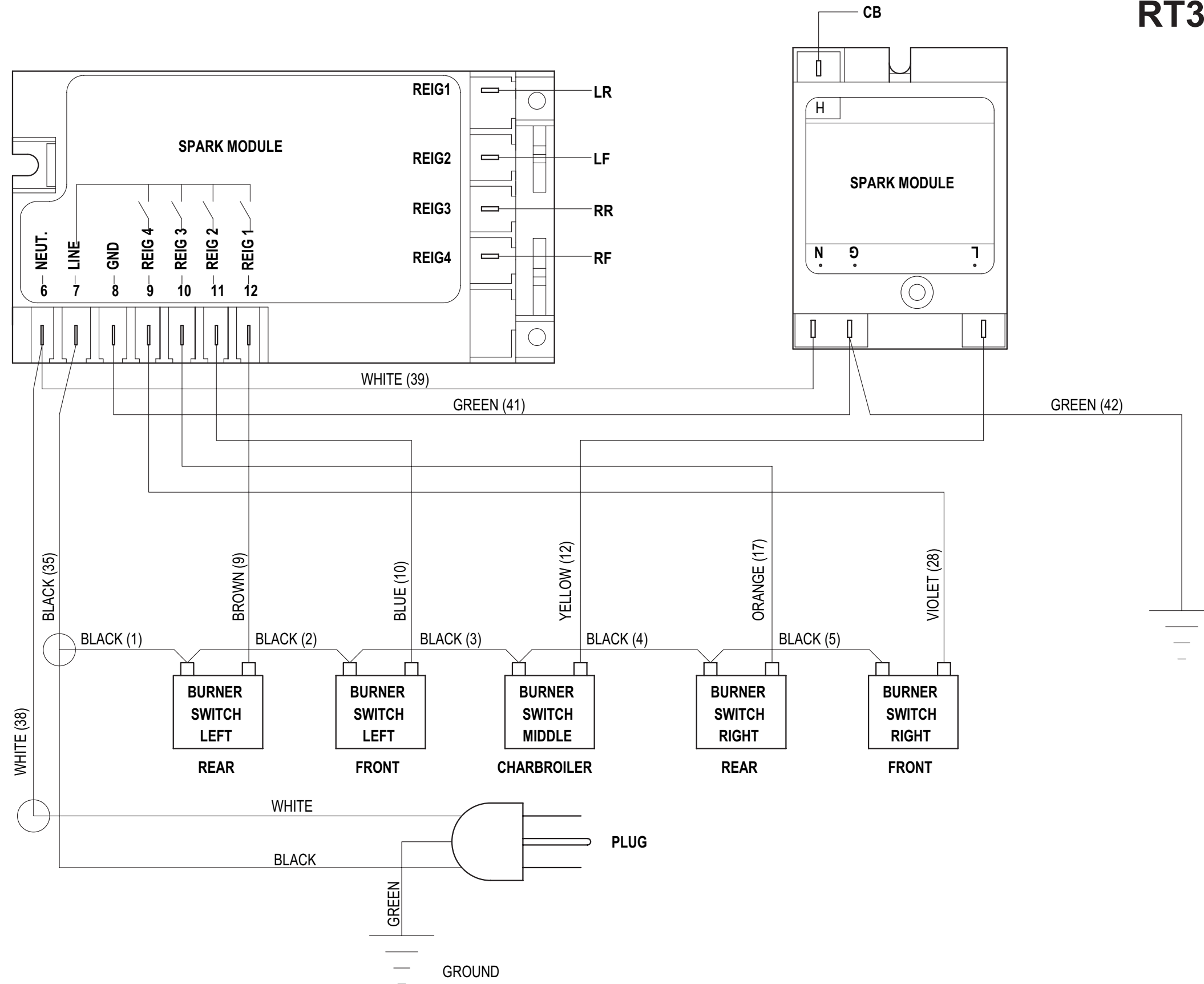

RT364G/RT364G-LP

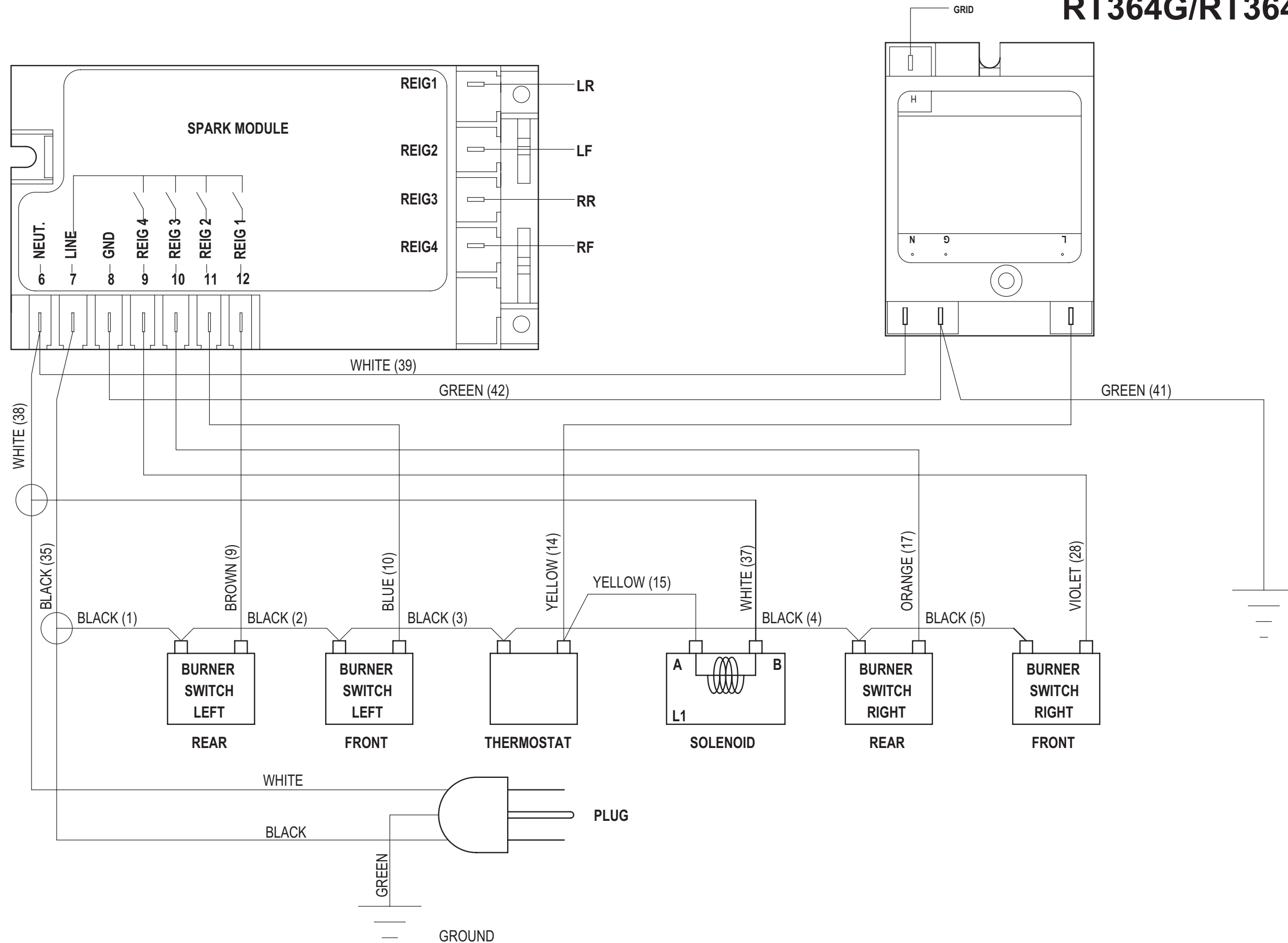

RT362F/RT362F-LP

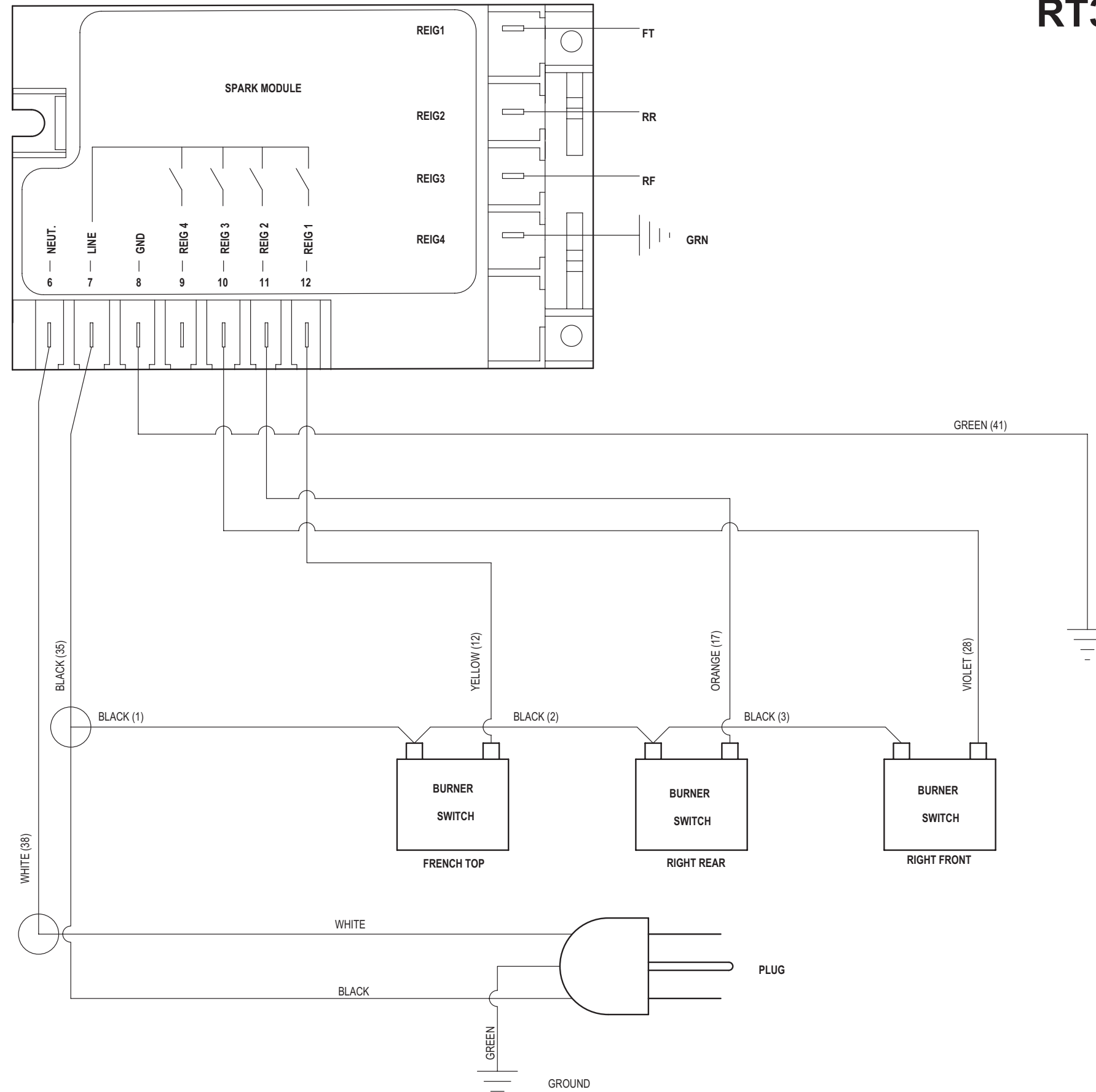

RT488/RT488-LP

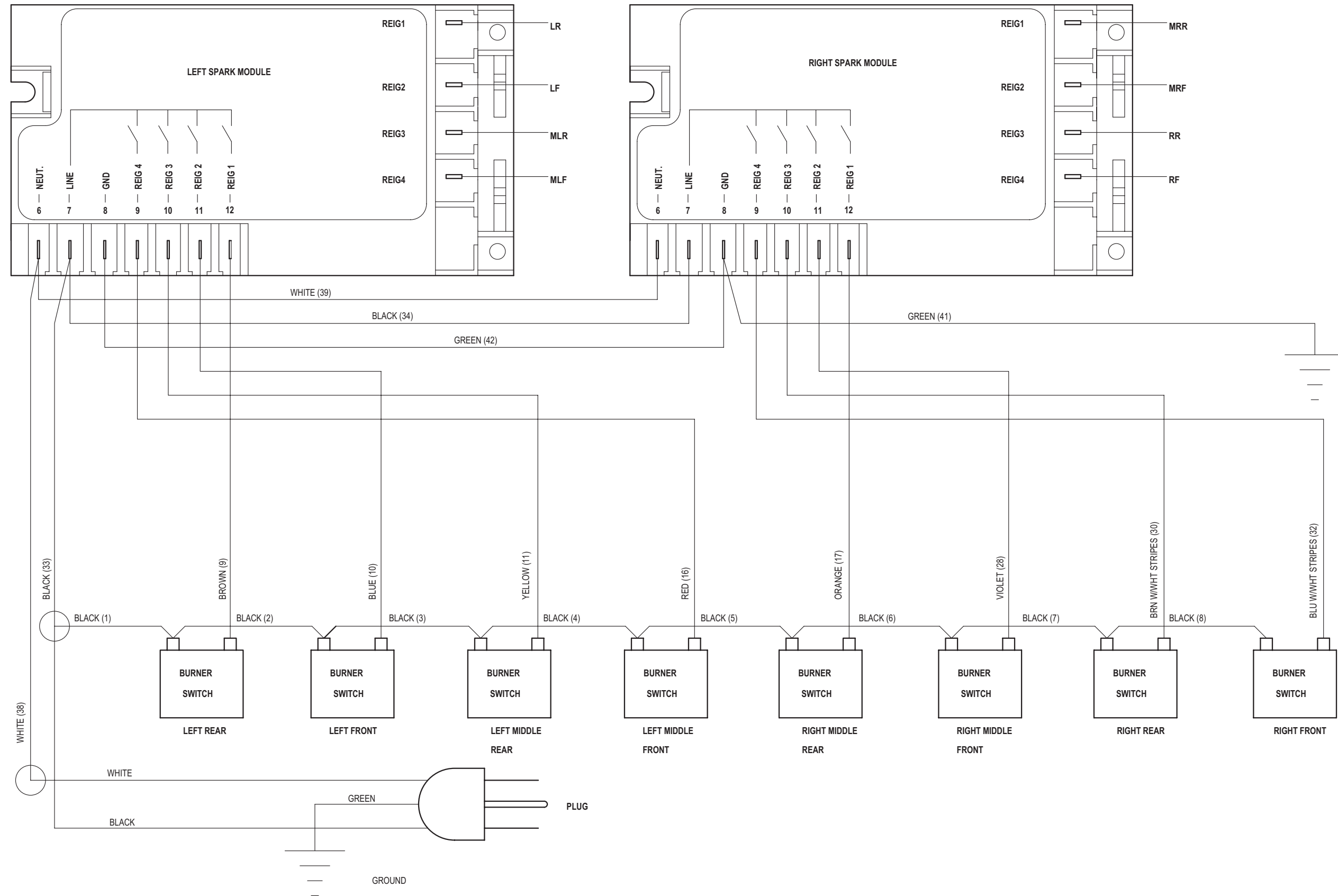

RT486C/RT486C-LP

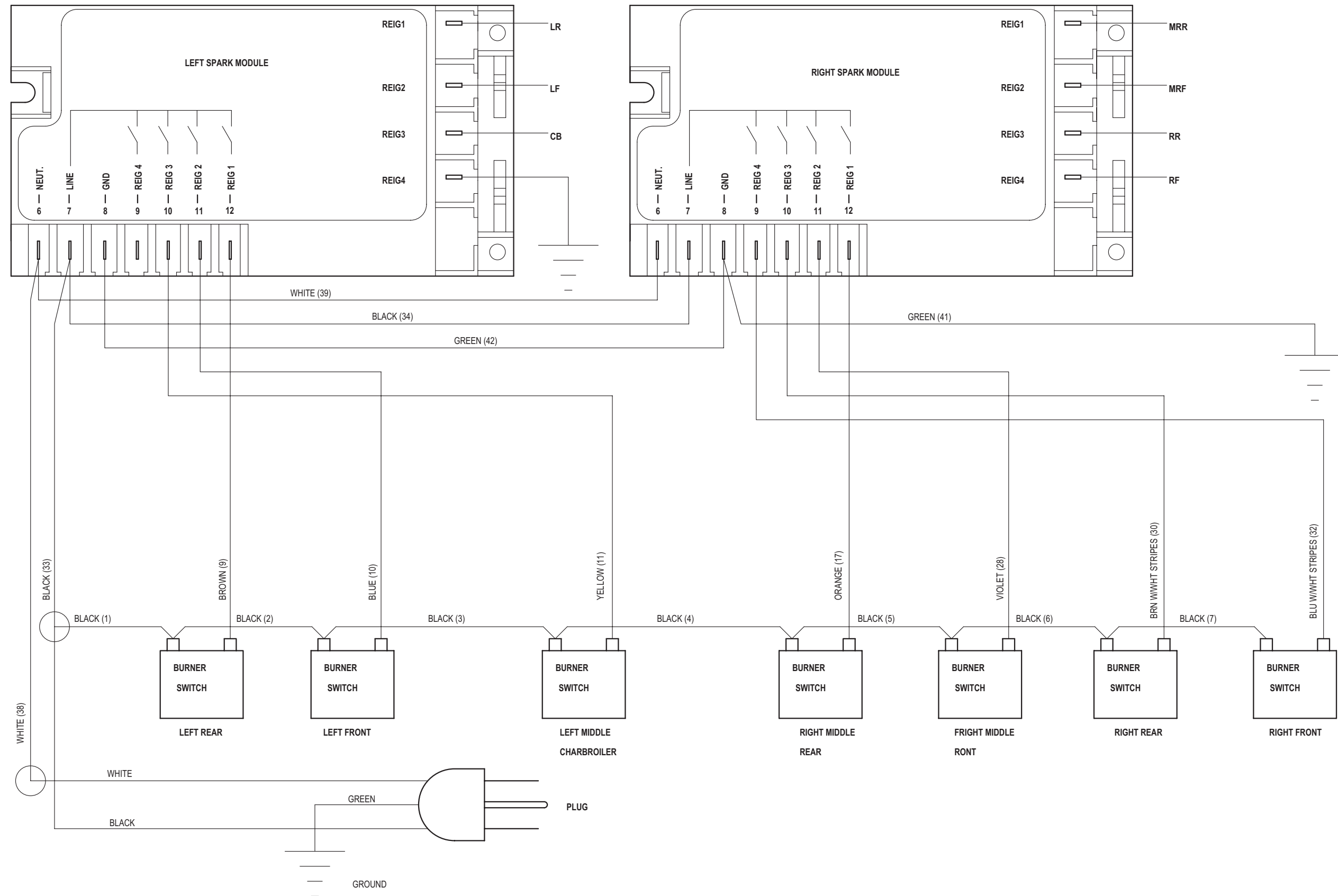

RT486G/RT486G-LP

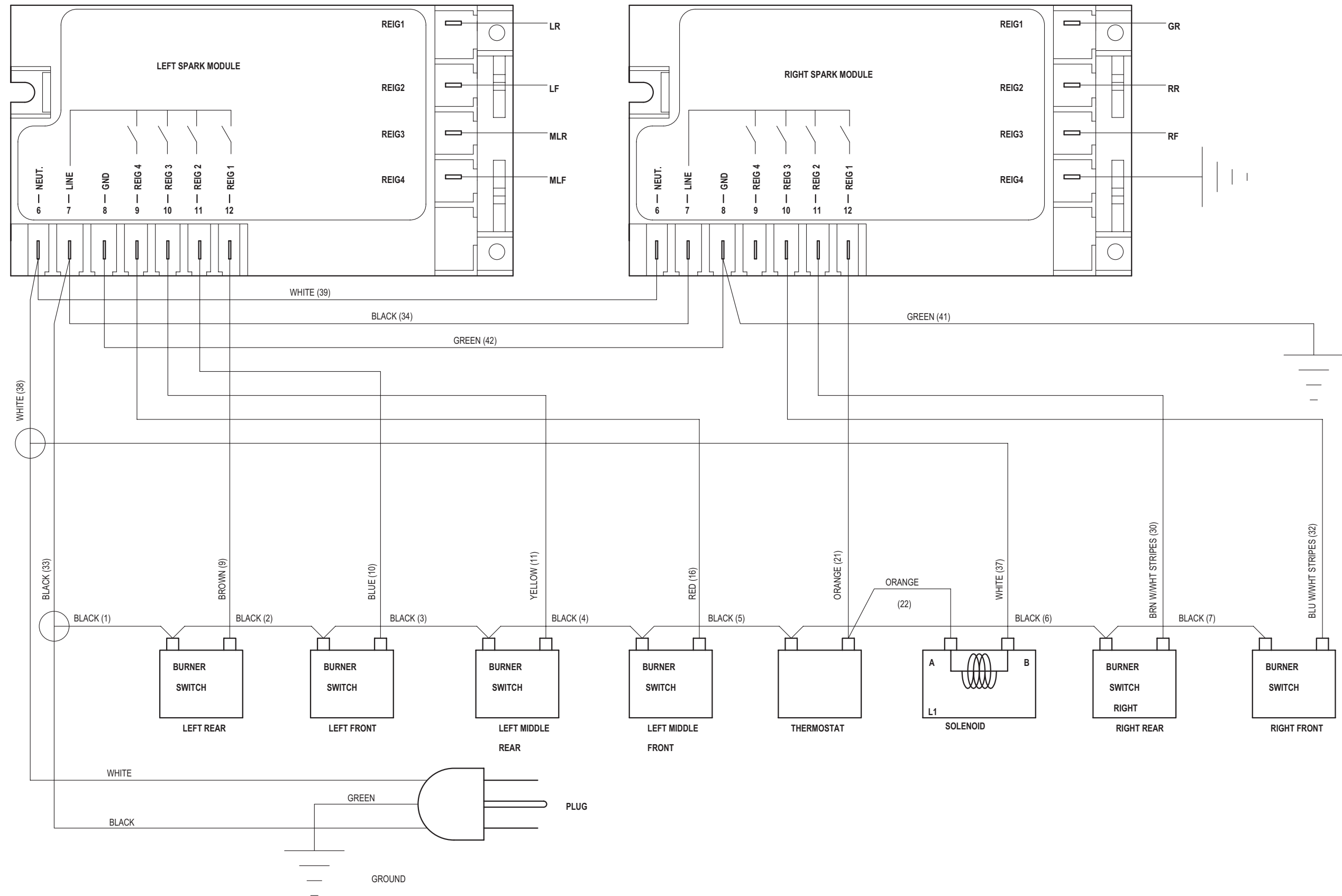

RT484CG/RT484CG-LP

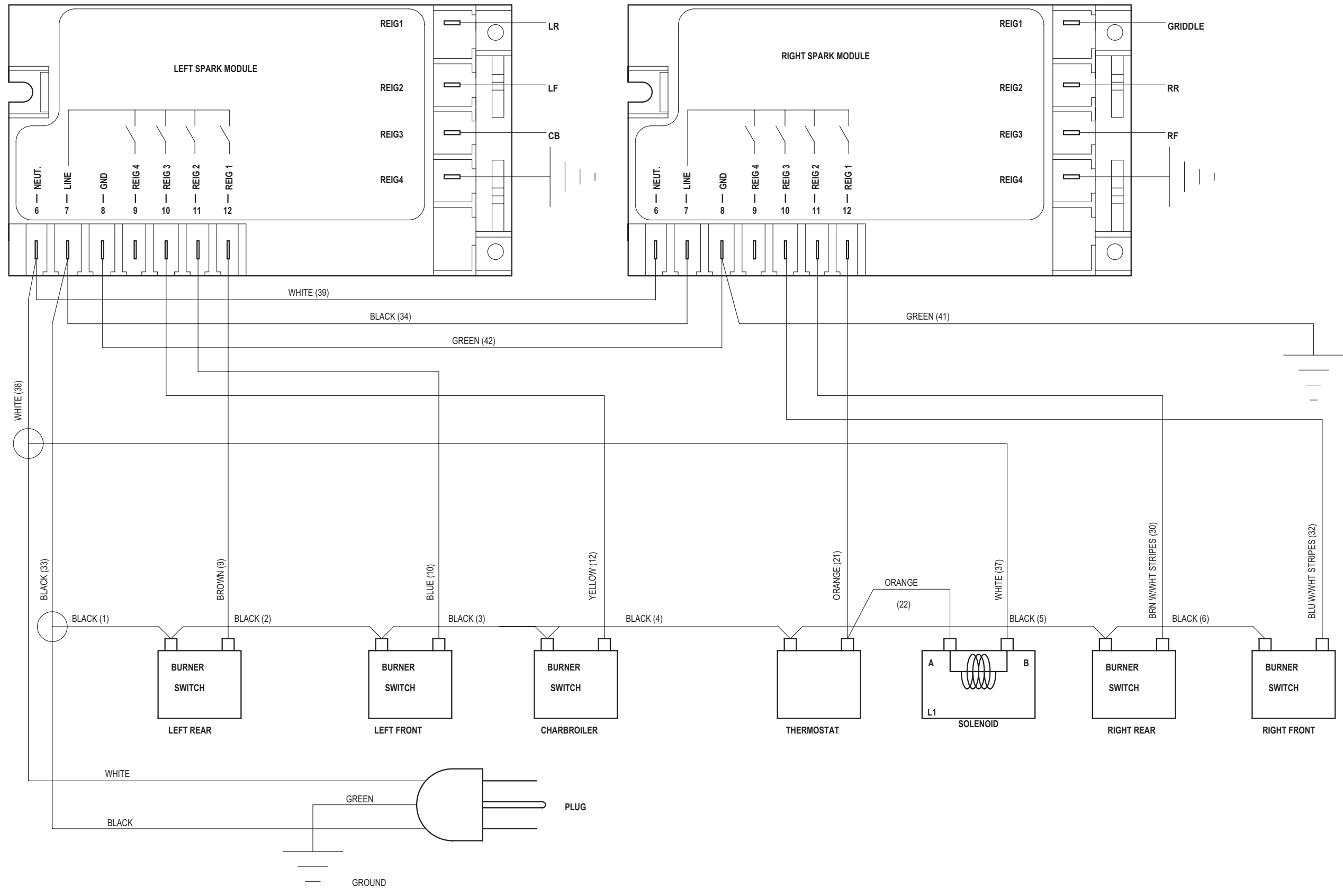

RT484DCRT484DC-LP

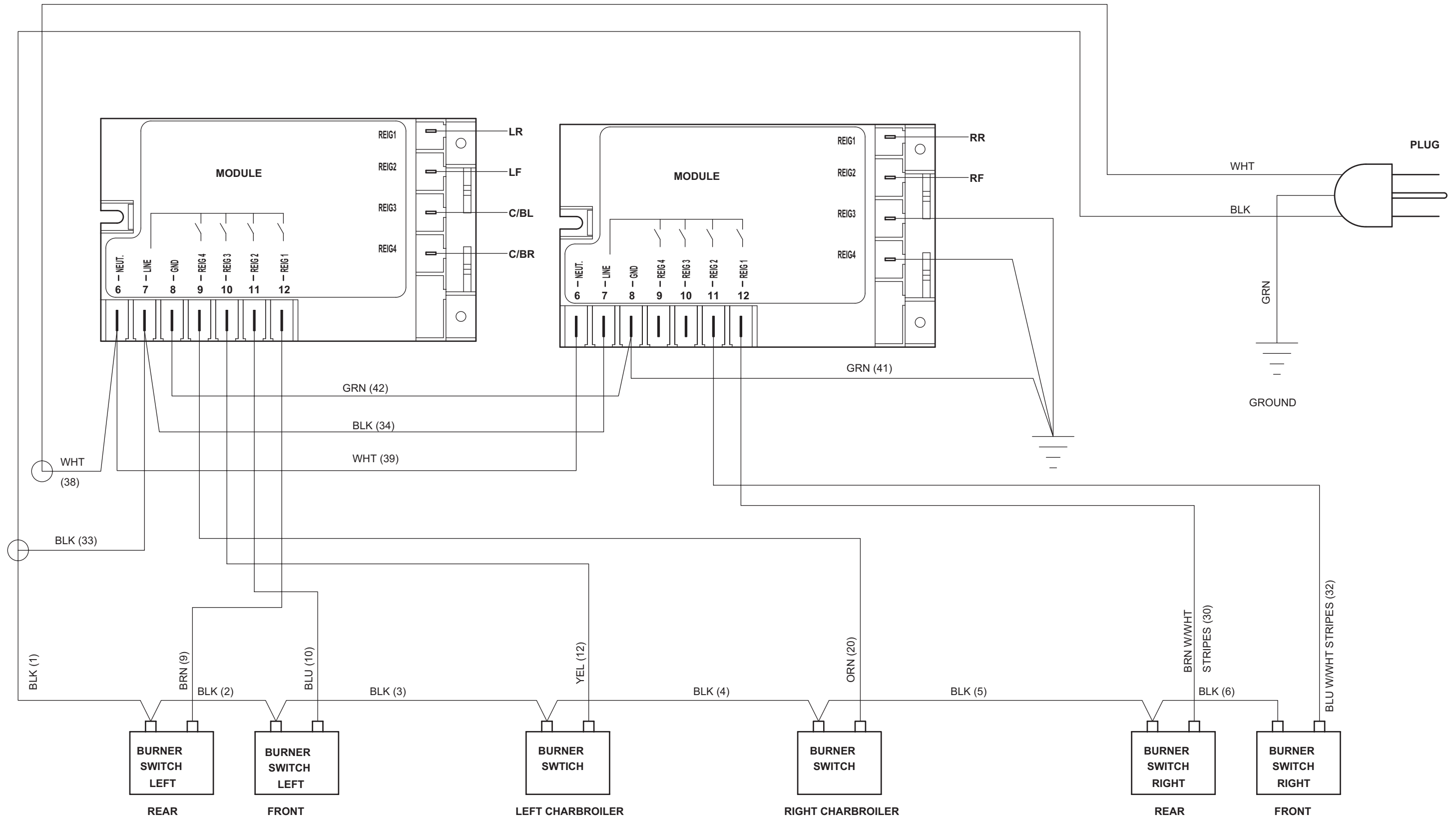

RT484DG/RT484DG-LP

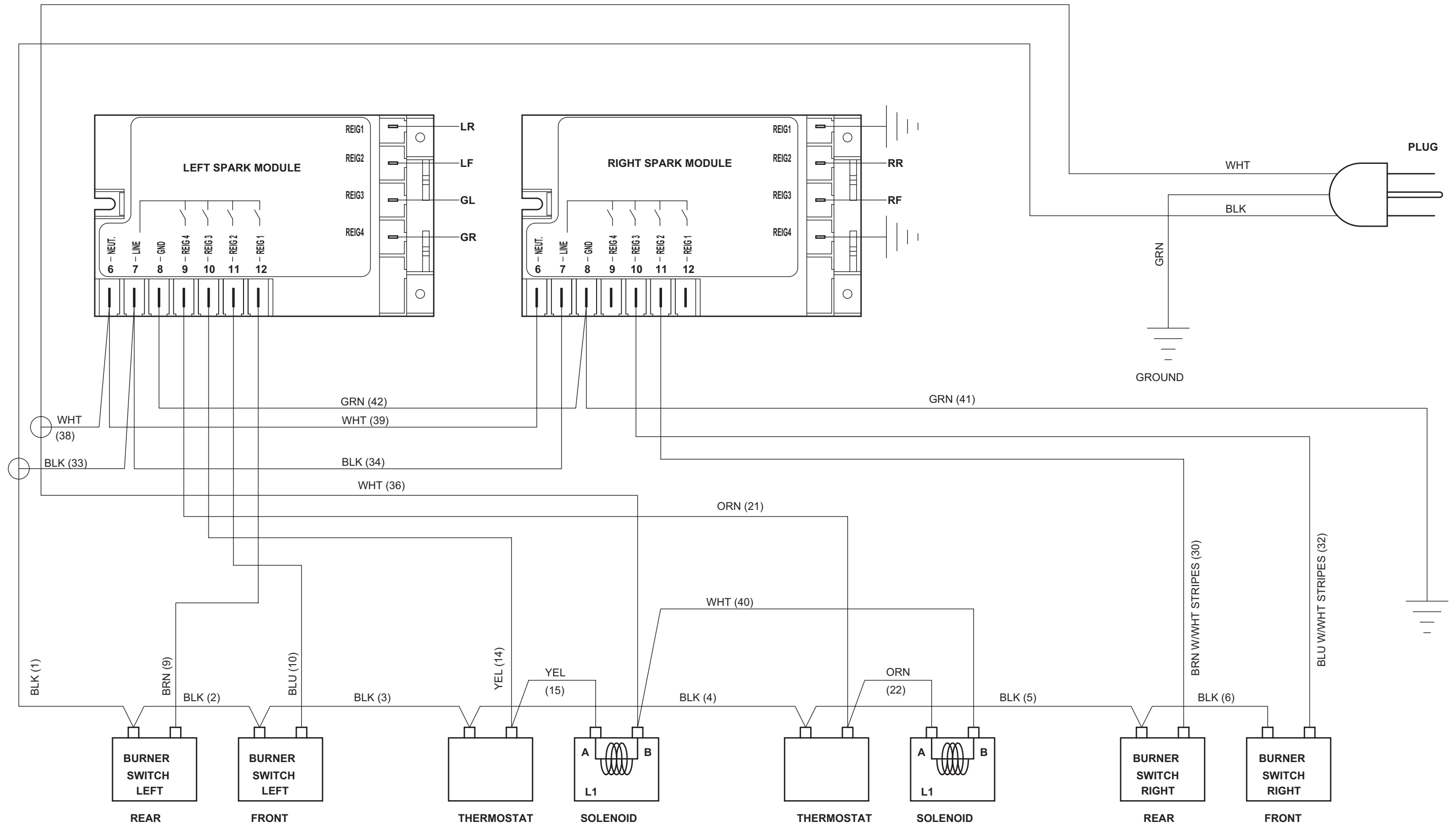

RT484F/RT484F-LP

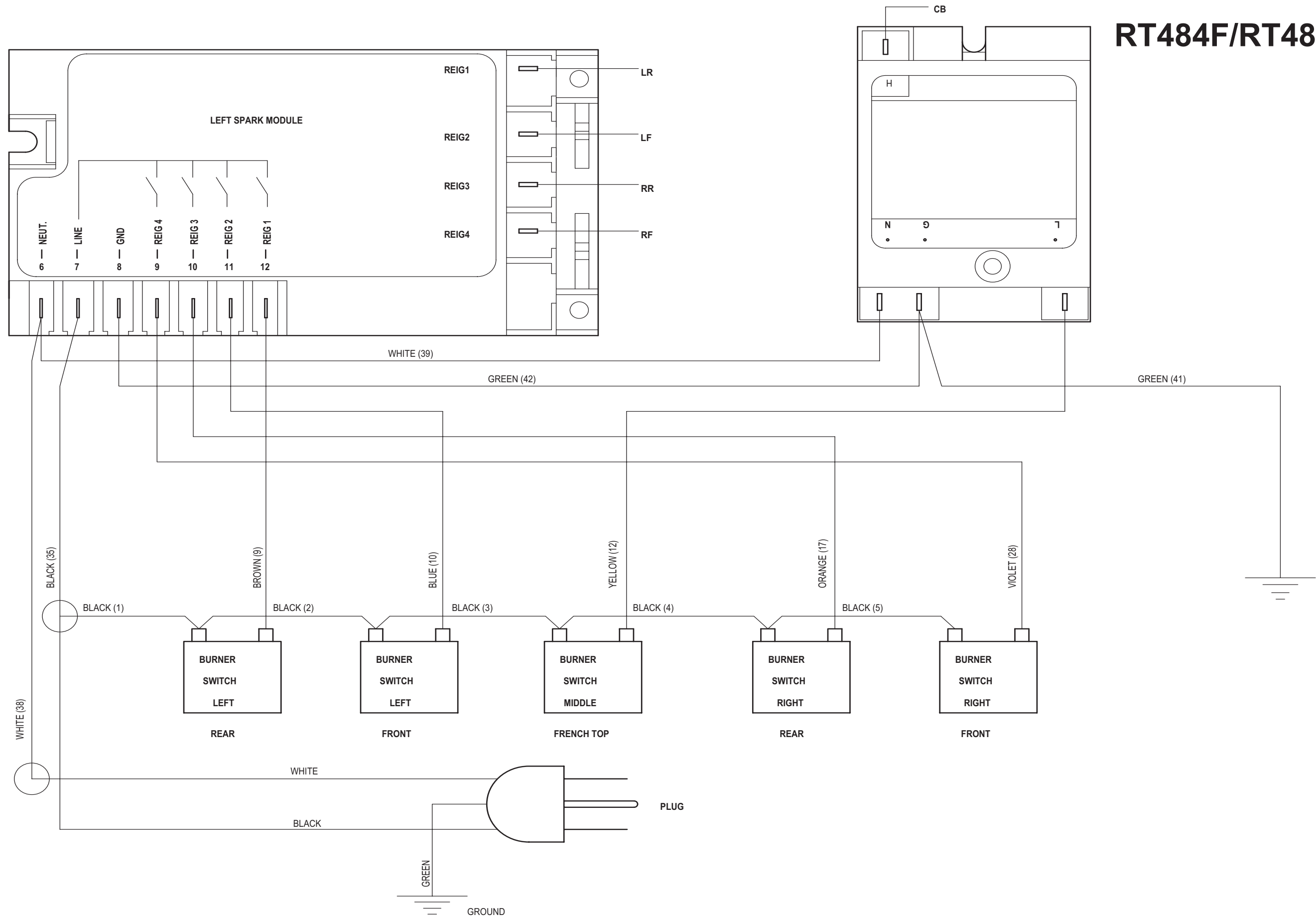

RT484F/RT484F-LP

