



Fast Track Troubleshooting

Model:
WA5451ANW/XAA

IMPORTANT SAFETY NOTICE – “For Technicians Only” This service data sheet is intended for use by persons having electrical, electronic, and mechanical experience and knowledge at a level generally considered acceptable in the appliance repair trade. Any attempt to repair a major appliance may result in personal injury and property damage. The manufacturer or seller cannot be responsible, nor assume any liability for injury or damage of any kind arising from the use of this data sheet.

SUPPORT INFORMATION

Publication # nwWA5451 Creation Date 09/22/2011

Training — Plus One <http://my.plus1solutions.net/clientPortals/samsung/>
Help — GSPN <http://service.samsungportal.com/>
Samsung Product Support TV <http://support-us.samsung.com/spstv/howto.jsp>
Customer information videos and chat programs. Programs for Fridges, Laundry, Ranges & D/W



Quick Test Mode

To enter press *Soil, Signal, & Power* simultaneously with the power off. 

1. All LED's light up and the washer beeps as it enters the Quick Test Mode.
2. The unit displays the software version for a second then clears the EEPROM.
3. After the displaying the software version, LCD will display Model information. If EEEE is displayed the PCB assembly is defective.
4. When the version is displayed, turn the Jog-Dial so that the version disappears. Press the following keys to test the various components
Press **Temp Key** to cycle through the Water Valve test (**Door does not need to lock**) in this order: Cold, Bleach, Hot, Rinse (Softener), & 3 cold valves then off.
Press **Spin Key** to test Circulation/Drain Pump.
Press **Soil Level Key** to test Water Heater
Press **Signal Key** to test the Door Lock/Unlock circuit
When either **Test or Spin** is displayed on the LCD, press **Start/Pause key** to conduct the motor test.
In **Test mode**, you can test the clockwise and counter-clockwise movement of the motor. However, the water level must satisfy the heater water level (24300) to enter Test mode.
In **Spin mode**, you can test the motor at a high rpm. The RPMs will also be displayed

Continuous Run Mode:

1. Press **Delay Start + Soil Level Key** for 7 sec during Power On State (Normal User Mode).
2. Once in Continuous Run Mode, The seven segments will no longer display "0000" and will alternate between displaying the number of cycles of the completed course and the remaining time of the course.
3. The Continuous Run Mode will repeat the previous cycle until continuous run mode is cancelled by pressing the same button combination for 7 sec.

Service Mode:

This mode allows more detailed operation tests and troubleshooting, to enter press **Signal & Extra Rinse** simultaneously with the power on. 

While in Service Mode the following tests can be performed:
Quick Spin Test = Delay Start & Temp: ★ This accelerates the drum motor from 0 to maximum RPM over a few minutes. **Note: Stay with the washer during this test, out of balance detection may be bypassed.**

Press the Start/Pause button during the test to hold its spinning speed for 10 minutes before going back to Quick Spin Test
Cycle Count = Press Signal key to view times the unit was used
Soft Ware # = Press Soil key to see the software version info
Fast Time Down = Press Temp key to advance to next cycle
Fault Code Test = Press the Spin button to view the stored fault codes – then turn Jog Dial to view error codes (Push Start/Pause while the code is displayed to view the number of cycles since the error occurred)

Peripheral (Main PCB) input Tests

1. Select Extra Rinse. Then turn the Jog-Dial so that the **Normal LED** is turned on. The Water Temperature will be displayed in Centigrade
2. Select Extra Rinse. Then turn the Jog-Dial so that the **Heavy Duty** is turned on. The water temperature will be displayed in Fahrenheit.
3. Select Extra Rinse. Then turn the Jog-Dial so that the **Perm Press LED** is turned on. The door status will be displayed (OP if open, CL if closed).
4. Select Extra Rinse. Then turn the Jog-Dial so that the **Sanitize LED** is turned on. The door lock Switch status will be displayed (UL if unlocked, Lo if locked).
5. **Water Frequency/Water Sensor Testing Select a cycle & start the washer, enter Service Mode & press Extra Rinse.** Turn the Jog Dial so that the **Bedding LED** is turned on. Next, press the Start/Pause Key. The Water Frequency will be displayed. The frequency will change as the unit fills

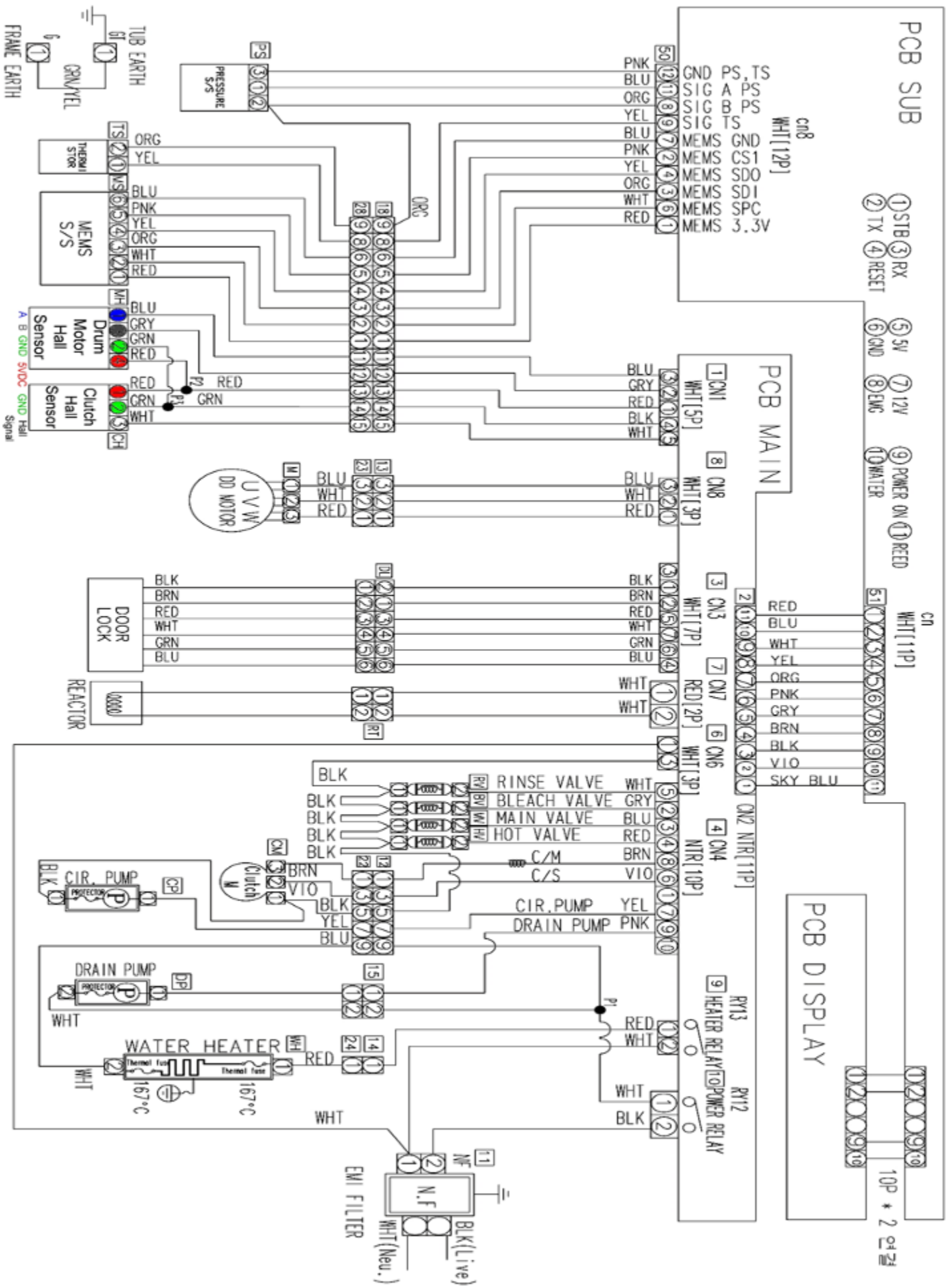

Washer Connector Checks WA5471

CN2 Interface

- 1 Standby (S/BLU)
- 2 TX (VIO)
- 3 -RX (BLK)
- 4 Reset (BRN)
- 5-6 5vdc (Gry-Pnk)
- 7-6 12vdc (Org-Pnk)
- 8 EMG - (YEL)
- 9 Power On (WHT)
- 10 Water Level (BLU)
- 11 Sub Reed (Red)

CN3

- 1-2 Door Lock - (Blk-Brn)
- 4 Unlock Contact - (BLU)
- 5 Lock Contact - (RED)
- 6 Reed Switch - (GRN)
- 7 5VDC (WHT)

CN8

- 1 Motor Pwr U Phase (Red)
- 2 Motor Pwr V Phase (Wht)
- 3 Motor Pwr W Phase (Blu)

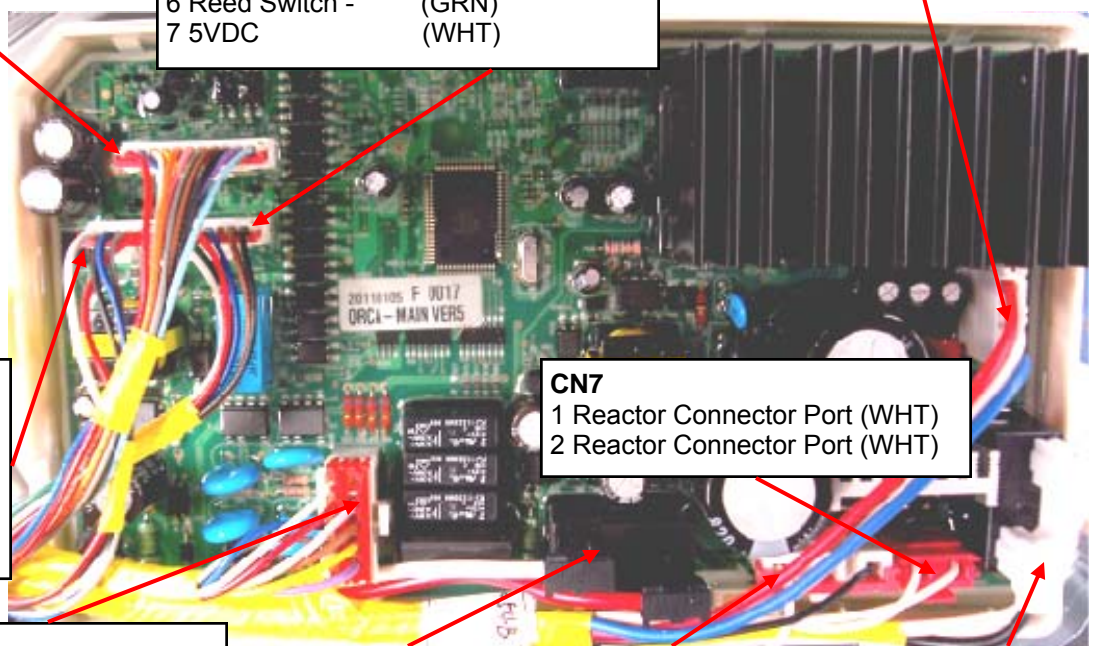

CN1

- 1-4 5vdc (Red - Grn)
- 2 Hall - B (GRY)
- 3 Hall - A (BLU)
- 4 GND - (BLK)
- 5 Clutch Hall - IC (WHT)

CN7

- 1 Reactor Connector Port (WHT)
- 2 Reactor Connector Port (WHT)

CN4 120vac

- 2-(CN6-3) Bleach Valve (Gry-Blk)
- 3-(CN6-3) Cold Valve (Blu-Blk)
- 4-(CN6-3) Hot Valve (Red-Blk)
- 5-(CN6-3) Rinse (Softener) Valve (Wht-Blk)
- 6 Clutch Contact (VIO)
- 7-(CN6-3) Cir. Pump (Yel-Blk)
- 8-(CN6-3) Clutch Mtr (Brn-Blk)
- 9-(RY12-2) Drain Pump (Pnk-Wht)

RY13 Relay

- 1 Heater (Red)
- 2 AC Neutral (Wht)

CN6

- 1 AC Neutral (Wht)
- 3 AC Line Common (Blk)

RY12 Relay

- 1 AC Line out (WHT)
- 2 AC Line (BLK)

A/C Power Check	Test 1	Test 2
Relay RY12 (Pwr Relay) Pin 2 (Black) and RY13 (Heater Relay) Pin 2 (White)	Plugged in 120VAC power on or off	Power on: CN6 1 (White -2 (Black) 120VAC
Heater Relay Check	Test 1	Test 2
Relay RY12 (Pwr Relay) Pin 1 (White) and RY13 (Heater Relay) Pin 1 (Red)	120VAC with the Heater On and 0VAC with the Heater off	Power Off, heater resistance is ~12Ω
Hall Sensor Check	Test 1	Test 2
Voltage at Pin #4 (BLK) and #3 (BLU) of CN1 Voltage at Pin #4 (BLK) and #2 (GRY) of CN1	Manually spin the drum to see the voltage change, Power On	Voltage at Pin #4 (BLK) and #1 (RED) of CN1 = 5VDC
	0Vdc or 3.75Vdc	
D-D Motor Check	Test 1	Test 2
Connector CN8 Pin 1 (Red), Pin 2 (White) and Pin 3 (Blue)	Power Off ~18Ω across Pins 1-2, Pins 1-3, & Pins 2-3	N/A
Clutch Motor	Test 1	Test 2
Connector CN4 PIN #8 (Brn) and CN6 PIN #3 (Blk) Test 2 resistance between clutch motor terminals	Power Off ~2 kΩ across CN4 PIN #8 (Brn) and CN6 PIN #3 (Blk)	Violet/Black - Brown = 0Ω Violet/Black - Black = ~2KΩ Brown - Black = ~2KΩ
	Test 1	Test 2
Pin #3 (BLK) of CN6 and Pin #7 (YEL) of CN4	120VAC with the Mtr On and 0VAC Off	Resistance Pin #3 (BLK) of CN6 to Pin #7 (YEL) of CN4 = ~20Ω

Door Lock Check	Test 1	Test 2
Resistance check CN3 Pin #5 (Red) and Pin #7 (Wht)	Power Off, resistance is Approx 0.2 Ω	Motor resistance at CN3 Pins 1-2 (Blk-Brn) 40KΩ
Door Unlock Check		Test 2
Resistance check CN3 Pin #4 (Blu) and Pin #7 (Wht)	Power Off, resistance is Approx 0.2 Ω	Motor resistance at CN3 Pins 1-2 (Blk-Brn) 40KΩ
Drain Motor Check	Test 1	Test 2
Voltage at Pin #1 of RY12 (WHT) and Pin #9 (PNK) of CN4	120VAC with the pump On and 0VAC with the pump off	Voltage at Pin #1 of RY12 (WHT) and Pin #9 (PNK) of CN4 should be ~14Ω
Water Valve Check	Test 1	Test 2
Voltage at Pin #3 (BLK) of CN6 to Pin #2 (GRY) of CN4 Bleach Valve, Pin #3 (BLU) of CN4 Cold Valve, Pin #4 (RED) of CN4 Hot Valve, Pin #5 (WHT) of CN4 Rinse Valve	120VAC with the Valve On and 0VAC with the Valve off	Power Off, valve resistance is from 1202Ω - 1245Ω
Cir. Pump Check		
Resistance check CN6 Pin #3 (Blk) CN4 Pin #7 (Yel)	Power Off, pump resistance is 20 Ω	N/A

Error Type	Error Mode	Details
	LED	
Water Level Sensor	LE 8	Check for water to the valves, clogged valve screens, defective valve solenoid coils. Check the water level / pressure sensor Check for 120VAC to the valve.
Motor Drive Error or Hall Sensor error	3E E3	Check the motor drive connector, it may be loose. The hall sensor may be disconnected, loose or damaged . Check for a foreign object inside the motor or motor damage. The stator might be loose or damaged. The drum might be overloaded from too many clothes or the relay or PCB might be defective.
Water Supply Error	nF 3	Check the water valve wiring harness. Check whether the water supply valve is clogged with foreign material and whether water is supplied properly. Check for reversed fill hoses Check water temperature, if sensed as higher than 50 °C in the Wool or Lingerie cycle it will create error. Check the relays, if they operate correctly replace the Main PCB.
Fill Hoses Reversed	nF1	Correct Hot/Cold hose connections

Error Type	Error Mode	Details
	LED	
Drain Error	nd	<p>Check for Foreign material entering the pump or hoses.</p> <p>Check to make sure the wiring harness is connected properly.</p> <p>Check the water pump terminal .</p> <p>Check for freezing.</p> <p>The water level fails to drop below the Reset Water Level within 30 minutes.</p>
Power Error	2E	<p>Make sure to check the operating voltage. (An error occurs when under or over voltage is supplied.) Check whether a plug receptacle is used. When the connecting wires are too small (extension cord use), a momentary low voltage may drop up to 10 V</p> <p>Main PBA fault (sometimes)</p>
	PF	Momentary Power Failure
Communication Error	AE	<p>Check the wire connections and terminal contacts between the sub and main PBAs.</p> <p>Check for disconnected wires.</p> <p>Check whether the sub PCB is short circuited because of moisture. If the main PCB's communication circuit is faulty, replace it.</p>
Switch Error (Main Relay Error)	E2	<p>Check whether either the Power switch or a tact switch (any button) is stuck down.</p> <p>Check whether the service PBA holding screws are fastened too tight pinching the contacts</p> <p>If the main PBA switching IC on/off error has occurred, replace the main PBA.</p>
	SR	<p>The "E2" error occurs if the main relay connections are incorrect. Check the connections. If there is no error in the connections, replace the main PBA</p>
Door Error	ds (Before operation)	<p>Check the door switch and latch alignment .</p> <p>Check the latch for damage</p> <p>Check the wiring harness to the latch.</p> <p>Check the door switch. Replace if faulty.</p> <p>Check the main PBA door sensing circuit. Replace if faulty.</p> <p>Finally verify he operation of the Main PCB</p>
Failed Lock	FL (Lock Fail)	
Unlock Failure	LO (Unlock Fail)	

Error Type	Error Mode		Details
	LED		
Heater Error	Hr (Heater Relay)		This can be a short or a wire disconnected to the heater circuit. This can also be problem with the tub contacting the heater or if the water in the tub is frozen or there is no water. The error is triggered by temperatures above 145C. If the heater has no error, this occurs because of a PBA relay malfunction. Check the wiring harness to the heater. An Hr error occurs if the steam heater, is faulty, replace it.
Overflow error	OE 1E		Water is supplied continually because the water level detection does not work. - Verify the drain is working properly, the water level detection does not work and water is supplied continually. Verify the water valves shut off fully. Finally check the water level sensor.
Temperature Sensor Error	tE1		The washing heater temperature sensor in the tub has an error. Check the connections for the washing heater temperature sensor connector.
Unbalance Error	dC		Check the type of laundry. Check whether it may cause an unbalanced situation.- Educate the consumer in this case, to press pause, reposition the load or remove a few items. Press start to continue and complete the wash cycle.
Mems or Harness Failure	8E		Check MEMS PCB ,Main PCB & Wire-harness MEMS sensor error. If the output from the MEMS sensor is over 4.5VDC (open) or below 0.5VDC (shorted) for 5 seconds this error will occur.
Foaming Detected	SUdS Sd		This occurs when too much foaming is detected. It is also displayed while foaming is removed. When the removal is finished, the normal cycle proceeds. (This is one of the normal operations. It is an error for preventing non-sensing faults.)
Clutch Motor Error	PE	Check the clutch motor windings and connector.	Clutch motor error. Occurs when the clutch motor position is not detected. The MICOM will attempt 3 times to determine the motor position. After the 3 rd attempt the error will appear. Clutch motor error. Occurs when the clutch motor position is not detected.
Clutch assembly hall sensor error	PE1	Check the clutch hall sensor and wiring.	Clutch assembly hall sensor error. The drum will shake to try to determine if the clutch is in the right position. After 15 attempts if the hall sensor is not communicating with the MICOM the error will occur.
<p>Check whether the washing machine is level to the floor with respect to the original position of the washing machine prior to service. Doing this now will reduce the need for a redo call and customer dissatisfaction.</p> <p>✓ Vibrations can shorten the lifetime of the product.</p>			

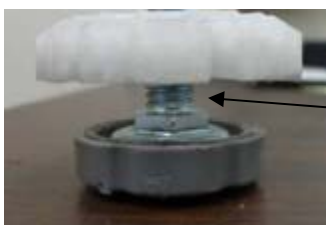

When installing a washer and dryer on the first, or second floor, do not exceed this leg adjustment height for stability.



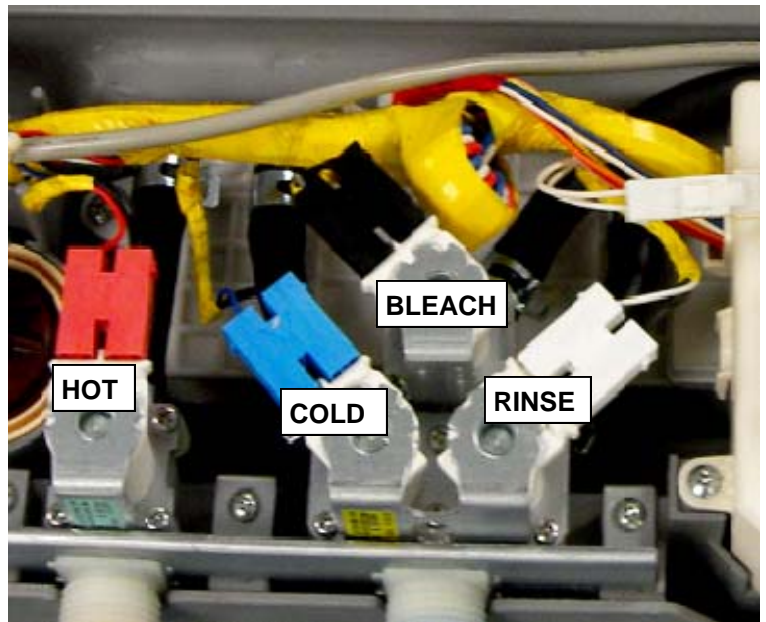
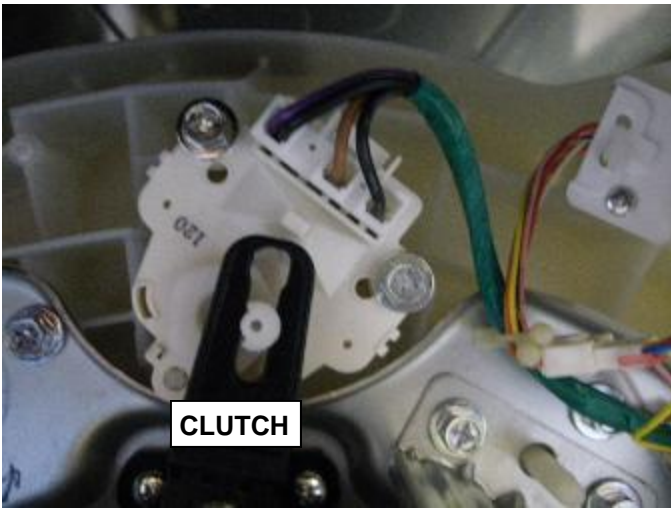

Softener is dispensed in the final rinse by the "RINSE" valve. This valve is only used to dispense the Sof-

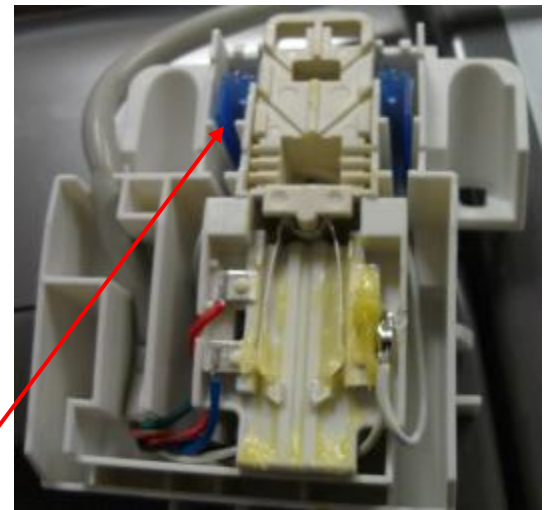

Door locked by. Reed Switch in blue plastic Door Lock Replaced as an Assembly.

