

MAYTAG

Jenn-Air

**Gas Cooktop
Service Manual**

P/N 16000443
(GC001-00)

Issued 1/95
Revised 5/98

Contents

SECTION 1. TROUBLESHOOTING	1-1
SECTION 2. COMPONENT ACCESS/REMOVAL	2-1
FAN MOTOR	2-1
RELAY, SPARK IGNITOR	2-1
PRESSURE REGULATOR	2-1
POWER SUPPLY RECEPTACLE	2-1
FAN SWITCH	2-2
STEM SWITCHES	2-2
GAS VALVE	2-2
ORIFICE ASSEMBLY - SUPPLY TUBE	2-2
TOP ASSEMBLY - GRILL PANS	2-3
IGNITOR	2-3
PAN SWITCH	2-4
SECTION 3. WIRING/PRODUCT SPECIFICATIONS	3-1
CG100	3-1
CG106	3-3
CG106-C	3-5
CG200	3-7
CG206	3-9
CG206-C	3-11
CCG406	3-13
629.12103	3-15
629.12104	3-17
629.12105	3-19
629.12106	3-21
CG205	3-23
CCG456	3-27
CG206-E	3-37

IMPORTANT

UNIQUE PRODUCT INFORMATION ON SPECIFIC MODELS MAY BE FOUND IN THE WIRING/PRODUCT SPECIFICATION SECTION OF THIS MANUAL.

GENERAL SAFETY PRECAUTIONS

This service information is intended to be used by a qualified service technician who is familiar with proper and safe procedures to be followed when repairing any electrical appliance. All tests and repairs should be performed by a qualified service technician who is equipped with proper tools and measuring devices. All replacements should be made by a qualified service technician using only MAYCOR replacement parts.

Improper assembly or adjustment may occur if service or repair is attempted by persons other than qualified service technicians or if parts other than MAYCOR replacement parts are used. Improper assembly or adjustment can cause hazardous conditions.

There can be risk of injury or electrical shock while performing services or repairs. Injury or electrical shock can be serious or even fatal.

SECTION 1. TROUBLESHOOTING

Note: In the event of malfunction, before replacing any component, check the following:

- Be sure 120 VAC power is supplied to unit.
- Be sure correct gas fuel, at correct pressure, is supplied to manifold inlet, that gas supply line is open and air has been bled from gasways.
- When an electrical component is non-operative, check to be sure the correct electrical leads are securely attached to it. Wire leads are color-coded and identified with stampings.
- When an electrical malfunction cannot be readily located, use a continuity tester to trace circuit, including checking of wire harness itself for separated wires, splices, etc.
- If ducting and wall cap are not connected to blower vent, be sure deflected drafts are not causing ignition failure or other burner flame disturbance.
- Good (or inoperative) parts, both electrical and mechanical, can often be easily identified by remote substitution; that is, for example, by disjoining wires from a component, or disjoining a stem switch from a valve, or a valve from a switch, and substituting the suspect part with a part known to be good outside the structure. This trial and error method is usually a time-saver.

GAS LEAKS

Never check for gas leaks with an open flame. Check for leaks using a soap and water solution.

CONDITION

No spark at ignitor(s)

POSSIBLE CAUSE

1. Loose wire connection to spark ignitor. Turning on *any* valve will cause both ignitors to spark simultaneously. *Both* ignitor lead wires must be connected to spark module for either to work correctly...

CORRECTION

- Reconnect loose wires.

2. Ignitor not grounded...

- Tighten mounting nut to assure solid ground.

3. Ignitor..

- Replace ignitor(s).

4. Spark module..

- Replace module.

Ignitor sparks - gas supply OK, won't light

1. Ignitor port in cap not in line with burner flash tube..

- Align ignitor cap so port is in-line.

2. Strong external drafts..

- Locate cause I.E. HVAC vent, advise customer on adjustment.

3. Aeration pan, air grille, grates not in position..

- Install parts for proper operation.

4. Burner not seated into unit properly or flash tubes not aligned with ignitor port..

- Seat or replace burner.

5. Primary air shutter set too far open..

- Adjust air shutter.

6. Blocked burner ports..

- Clear with pen or replace burner.

Ignitor fails through one valve, but works through another.

1. Stem ignition switch not securely seated..

- Seat switch securely.

CONDITION**POSSIBLE CAUSE****CORRECTION**

	<ol style="list-style-type: none"> 2. Stem ignition switch (On left side switch assemblies, the lower switch is the ignition switch).. 	<ul style="list-style-type: none"> • Replace switch (On left side, replace entire switch assembly).
	<ol style="list-style-type: none"> 3. Valve, no click heard (valve fails to rotate through full 175°, whereby failing to activate stem switch).. 	<ul style="list-style-type: none"> • Replace valve.
	<ol style="list-style-type: none"> 4. Switch wiring.. 	<ul style="list-style-type: none"> • Check connections: Black wire - male load plug to stem switch. Yellow wire - Stem switch to spark module. White wire - spark module to male load plug. • Check splices and connections for proper continuity.
Ignitor keeps sparking on setting other than "LITE"	<ol style="list-style-type: none"> 1. Stem switch, internal contacts won't open.. 2. Stem switch.. 3. Valve.. 4. Spark module.. 	<ul style="list-style-type: none"> • Replace switch. • Check wiring against diagram. • Replace valve. • Replace module.
Binding valve stems	<ol style="list-style-type: none"> 1. Valve.. 2. Stem switch or assembly.. 	<ul style="list-style-type: none"> • Replace valve. • Replace switch.
No "manual" fan operation	<ol style="list-style-type: none"> 1. Rocker switch, contacts open.. 2. Fan motor (windings open-shorted) 	<ul style="list-style-type: none"> • Replace switch. • Replace motor.

CONDITION

No "auto" fan operation (Fan should run when left side valve(s) turned on and aeration pan removed)

POSSIBLE CAUSE

1. Upper stem - switch on either L.H. assembly..
2. Reversed stem switch wires..
3. Relay..
4. N.C. pan switch or lever arm..
5. Fan motor..

CORRECTION

- Replace switch assembly or seat switch securely.
- Check wiring. Brown wires should be on upper switches, yellow wires on lower.
- Replace relay.
- Bend lever arm so that projection pin on aeration pan makes contact or replace switch.

Fan operates automatically when it shouldn't

1. Projection pin on aeration. Pan not depressing pan switch fully when installed on L.H. side..
2. N.C. pan switch..
3. Stem switch or relay..

- Check wiring.
- Replace motor.
- Bend lever arm so that projection pin on aeration pan makes contact.
- Replace switch.
- Check wiring against diagram. Replace switch or relay.

Fan won't shut off

1. Rocker switch..
2. Relay or motor

- Replace switch.
- Check wiring against relay.

No flame - gas not reaching any burner

1. Line gas valve turned off, or air in manifold or supply line..
2. Gas supply pressure to unit exceeding 14.0 W.C...

- Turn supply valve on. Bleed gas line at regulator.
- Reduce gas supply pressure (may require additional customer installed pressure regulator).

CONDITION	POSSIBLE CAUSE	CORRECTION
	3. Pressure regulator on unit or supply line..	• Replace regulator.
	4. Pressure regulator on unit or supplyline mounted backward (arrow on regulator body indicates direction of flow)..	• Reverse regulator.
	5. Conversion cap in pressure regulator missing or unseated..	• Check cap. Reseat.
	6. Gas valve..	• Replace entire assembly.
	7. Orifice fitting: Hood blocked or screwed tight against internal pin. Blockage within gasway.	• Clear with toothpick, back hood off pin at least 1 1/4 turns. Replace orifice fittings.
Flame blows away from burner ports - gas flows too high	1. Pressure regulator, pressure regulator cap is inverted (set for LP at 10" W.C. instead of natural at 5" W.C.)..	• Replace regulator, invert conversion cap.
	2. Oversize outlet hole in orifice hood..	• Replace entire orifice fitting
	3. Wrong orifice hood installed..	• Check color code on orifice hood (L.H. fittings are black, R.H. side fittings are brass).
	4. Primary air shutter set too far open..	• Adjust air shutter.
Flame too soft or lazy - gas flow too low	1. Gas supply pressure to unit below 6.0" W.C...	• Supply pressure must be increased. Advise customer on correction required.

CONDITION**POSSIBLE CAUSE****CORRECTION**

2. Wrong orifice hood installed..
3. Orifice hood..
4. Primary air shutter set too far closed..

- Check color code on orifice hood (L.H. side fittings are black, R.H. side fittings are brass).
- Clear with pen. Back hood off pin at least 1 1/4 turns.
- Adjust air shutter.

No gas or incorrect flow at "MED" or "LO" setting.

1. Center stem adjustment..

- Adjust center stem under knob to correct flame. Clockwise to reduce, counterclockwise to increase.

Note: Correct adjustment at the "LO" setting automatically adjusts the "MED" setting.

2. Gas valve (flow won't adjust through center stem)..

- Replace gas valve.

Unit not exhausting properly, or fan shuts off approximately 20 min. into operation

1. Ducting diameter too small, length of system too long, obstructions, too many elbows, or installed back to back..

- Advise customer to have ducting corrected according to installation instructions.

2. Fan motor..

- Replace motor. Upon completion, if short cycling exists, problem is *generally ducting*, not motor.

SECTION 2. COMPONENT ACCESS/REMOVAL

DISCONNECT POWER SUPPLY AND/OR GAS SUPPLY TO UNIT BEFORE ATTEMPTING SERVICE.

FAN MOTOR

1. Remove electrical box cover and cut the blue, white and green motor wires approximately 2" from crimp connectors. This will allow enough wire to rewire new fan motor wires with wire nuts and tape.
2. Loosen cable clamp on Bx cable and remove fan wire harness.
3. Remove mounting nuts on fan motor cover and lift assembly off.
4. Blower wheel, motor, isolators and motor band are now accessible.

To install, reverse procedure. Make sure fan wires are secure in wire nuts and taped.

RELAY, SPARK IGNITOR

1. Remove electrical box cover.
2. Relay is mounted on L.H. side of box. Remove screws from outside of electrical box to release relay. Disconnect wires from relay terminals.
3. Spark ignitor is mounted on R.H. side of box. Remove nut from outside of electrical box and lift ignitor up and out from locator tab. Disconnect wires from ignitor terminals.

To install, reverse procedure.

PRESSURE REGULATOR

1. Turn gas supply to unit off and disconnect supply line from bottom of pressure regulator.
2. Regulator is mounted directly in front of electrical box and may be removed with pipe wrench.

To install, reverse procedure.

Make sure that a high quality pipe joint compound acceptable for L.P. and natural gas or approved Teflon tape is applied to all thread connections. Once gas supply is turned on to unit, check connections for leaks with a soapy solution. If leak is detected, turn gas supply off immediately and correct leak. Test system again.

POWER SUPPLY RECEPTACLE

1. Unplug power supply cord from male receptacle on lower front corner of plenum.
2. Remove electrical box cover.
3. Disconnect wires from receptacle and squeeze retainer bracket together while pushing receptacle out. If bracket is too tight, an alternative method would be to remove screw from inside retainer bracket.

To install, reverse procedure.

FAN SWITCH

1. Remove air grill which exposes control panel mounting screws.
2. Remove screws, slide control panel assembly toward back of unit while lifting up.
3. Disconnect wiring and remove panel nuts holding switch in place.

To install, reverse procedure.

STEM SWITCHES

1. Remove control assembly panel and fan switch wires. Set panel off to side.
2. Stem switches are now visible and may be removed by lifting them up off of gas valve stems.
3. Disconnect wires. **Remember: Blue piggybacked switches are on L.H. side, brown single switches are on R.H. side. Do Not reverse!**

To install, reverse procedure.

GAS VALVE

1. Turn gas supply to unit off and disconnect supply line from bottom of pressure regulator.
2. Remove pressure regulator with pipe wrench and set aside.
3. Remove gas valve mounting screws from underside of unit.
4. Remove control panel assembly and stem switches.
5. Carefully loosen all supply tube fittings from gas valve body and lift gas valve body out.

When installing new gas valve, make sure outlet tubes are facing toward front of unit.

To install, reverse procedure.

Make sure that a high quality pipe joint compound acceptable for L.P. and natural gas or approved Teflon tape is applied to all thread connections. Supply tube fittings on gas valve body do not require compound prior to tightening. Once gas supply is turned on to unit, check connections for leaks with a soapy solution. If leak is detected, turn gas supply off immediately and correct leak. Test system again.

ORIFICE ASSEMBLY - SUPPLY TUBE

To Remove Orifice Assembly:

Unit must be removed from countertop to access the orifice assemblies and/or supply tubes.

1. Turn gas supply to unit off and disconnect supply line from bottom of regulator.
2. Disconnect electrical cord and ducting below unit. Loosen tie down screws from underside of burner box.
3. Remove unit from countertop and place on well protected surface to avoid damage to unit and flooring.
4. Remove screws from access panel located at front of burner box.
5. Loosen supply tube nut on respective orifice assembly.
6. Remove orifice assembly mounting nut from inside grill pan basin. Orifice will now lift out from opening.

To Remove Supply Tube:

Note: If you are removing a rear supply tube, you must follow the preceding steps (steps 1 - 5). Additionally, you must remove the control panel assembly to gain access to supply tube nuts on gas valve body.

To install, reverse procedure.

Make sure that a high quality pipe joint compound approved for L.P. and natural gas or approved Teflon tape is applied to all thread connections. Supply tube fittings on gas valve and orifice bodies do not require compound prior to tightening. **Once gas supply is turned on to unit, check connections for leaks with a soapy solution. If leak is detected, turn off gas supply immediately and correct leak. Test system again.**

TOP ASSEMBLY - GRILL PANS

1. Follow steps 1-3 under orifice assembly - Supply Tube.
2. Remove control panel assembly.
3. Remove screws around top of each grill pan and screws inside plenum top.

Top assembly will now lift off.

To Remove Grill Pan:

1. Follow the preceding steps 1-3.
2. Remove orifice assembly mounting nuts from respective grill pan.

3. Remove mounting screws from outside edge of burner box.
4. Remove electrical box cover and disconnect ignitor lead wire from spark ignitor.
5. Carefully lift grill pan at rear while feeding orifice bodies back from pan. At same time, ignitor lead wire will come out with pan.
6. Remove ignitor, mounting nut and washer from bottom of grill pan.

Make sure new top gasket is installed on new pan prior to installation.

To install, reverse procedure.

IGNITOR

1. Remove electrical box cover and disconnect ignitor lead wire from spark ignitor.
2. Attach a small guide wire approximately 15" long to terminal end of ignitor lead. (This will be used to pull new ignitor lead wire back to electrical box.)
3. Remove screw from access panel on burner box bottom. Ignitor mounting nut and washer is now accessible.
4. Remove nut and washer, lift ignitor up and out of grill pan. Disconnect guide wire underneath grill pan and bend to side until new ignitor is mounted into grill pan. Once this is done, guide wire may be attached to terminal and pulled back to electrical box for connection on spark ignitor.
5. Install electrical box cover.

PAN SWITCH

1. Remove screws from access panel located at front of burner box.
2. Disconnect wires from micro switch.
3. Remove mounting screws and

washers from switch body and lift out from front.

To install, reverse procedure. Make sure projection pin on aeration pan will engage switch. Adjust if necessary.

PAN SWITCH

1. Remove screws from access panel located at front of burner box.
2. Disconnect wires from micro switch.
3. Remove mounting screws and

washers from switch body and lift out from front.

To install, reverse procedure. Make sure projection pin on aeration pan will engage switch. Adjust if necessary.

SECTION 3. WIRING/PRODUCT SPECIFICATIONS

CG100

OVERALL WIDTH	OVERALL DEPTH	CUTOUT WIDTH	CUTOUT DEPTH	BTU's	GRILL BURNERS	SURFACE BURNERS
18 1/16	21 1/2	17 1/8	20 15/16	LP	8,000	NA
				NAT	8,000	NA

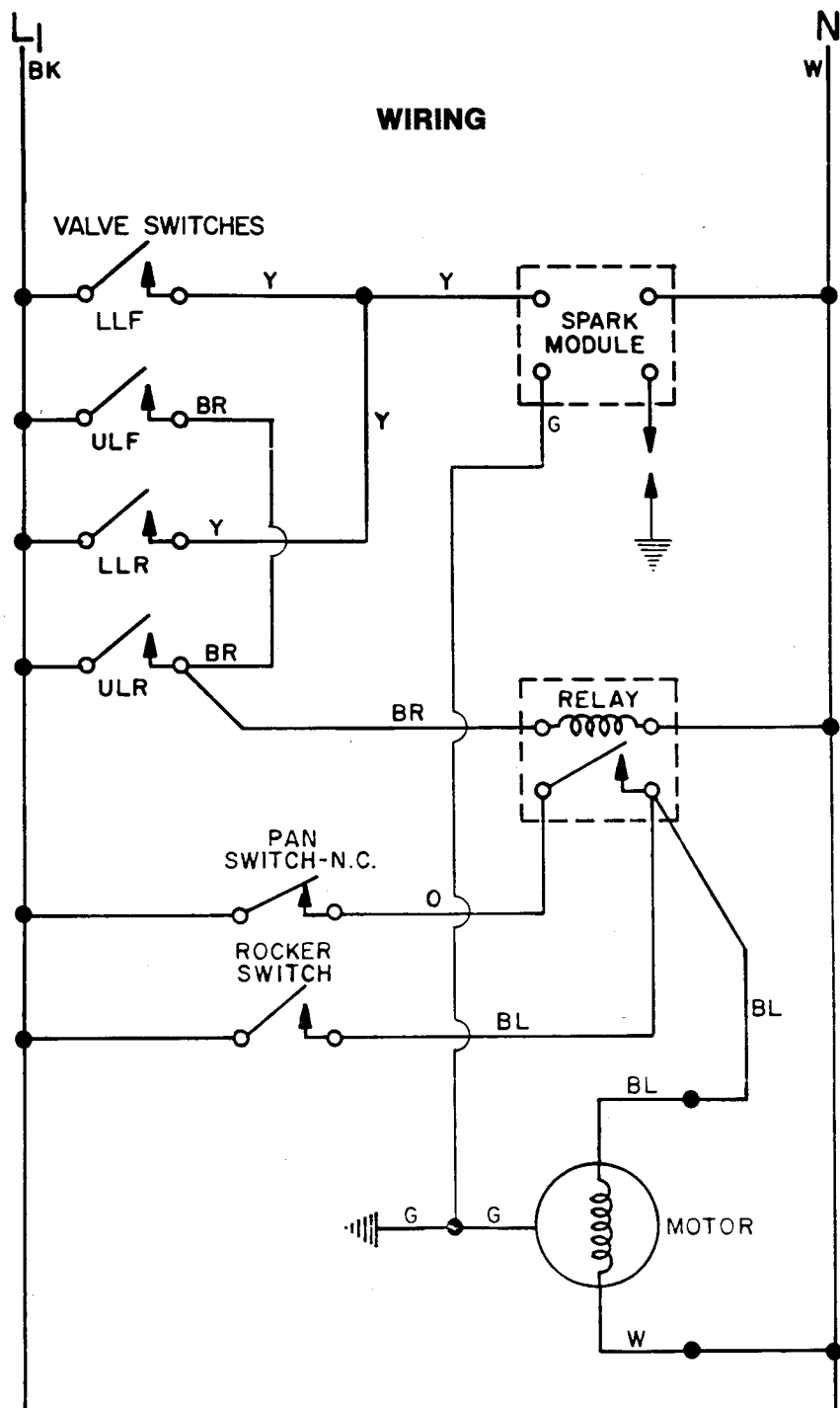

CG106

OVERALL WIDTH	OVERALL DEPTH	CUTOUT WIDTH	CUTOUT DEPTH	BTU's	GRILL BURNERS	SURFACE BURNERS
18 1/16	21 1/2	17 1/8	20 15/16	LP	8,000	NA
				NAT	8,000	NA

WIRING

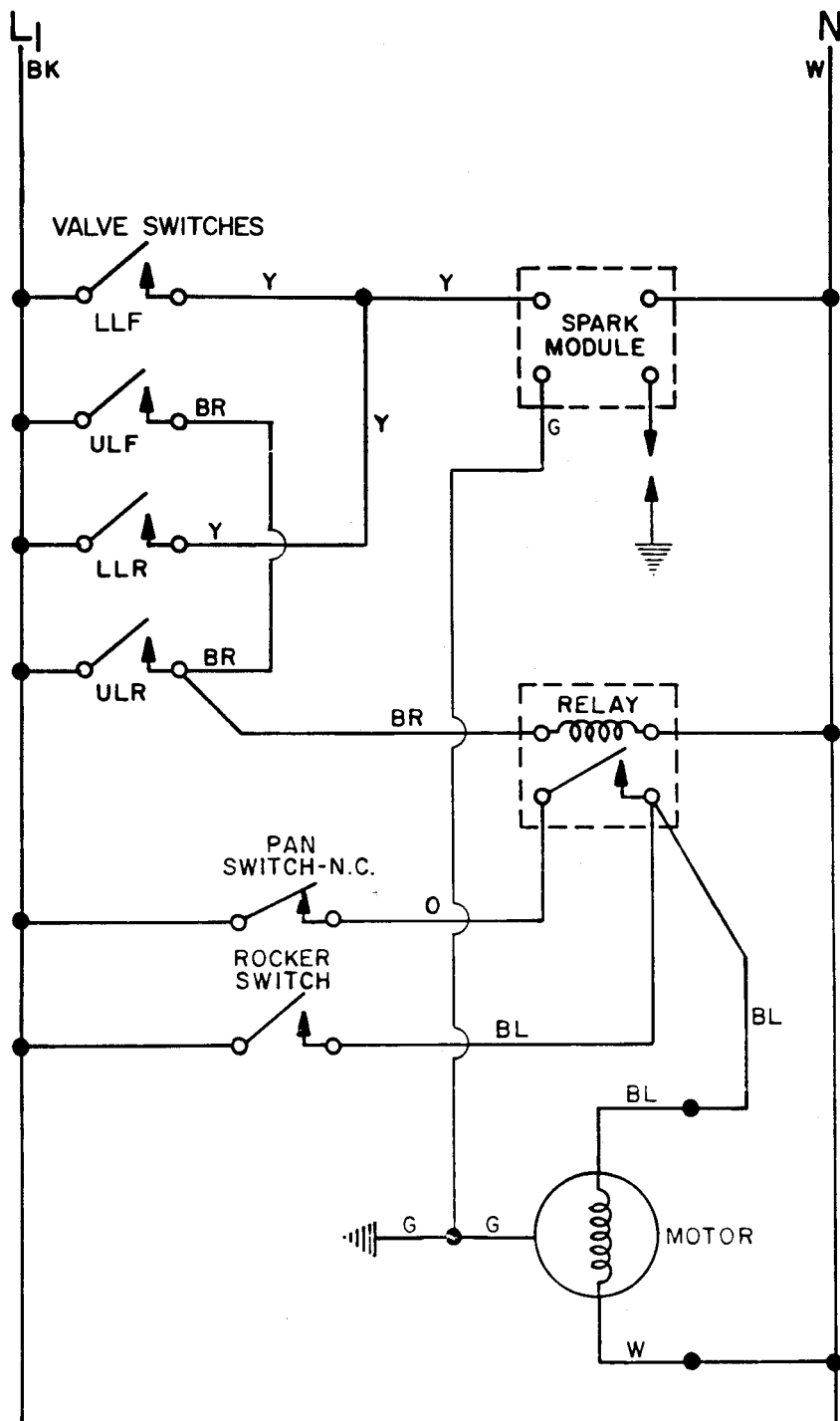

CG106-C

OVERALL WIDTH	OVERALL DEPTH	CUTOUT WIDTH	CUTOUT DEPTH	BTU's	GRILL BURNERS	SURFACE BURNERS
18 1/16	21 1/2	17 1/8	20 15/16	LP	8,000	NA
				NAT	8,000	NA

WIRING

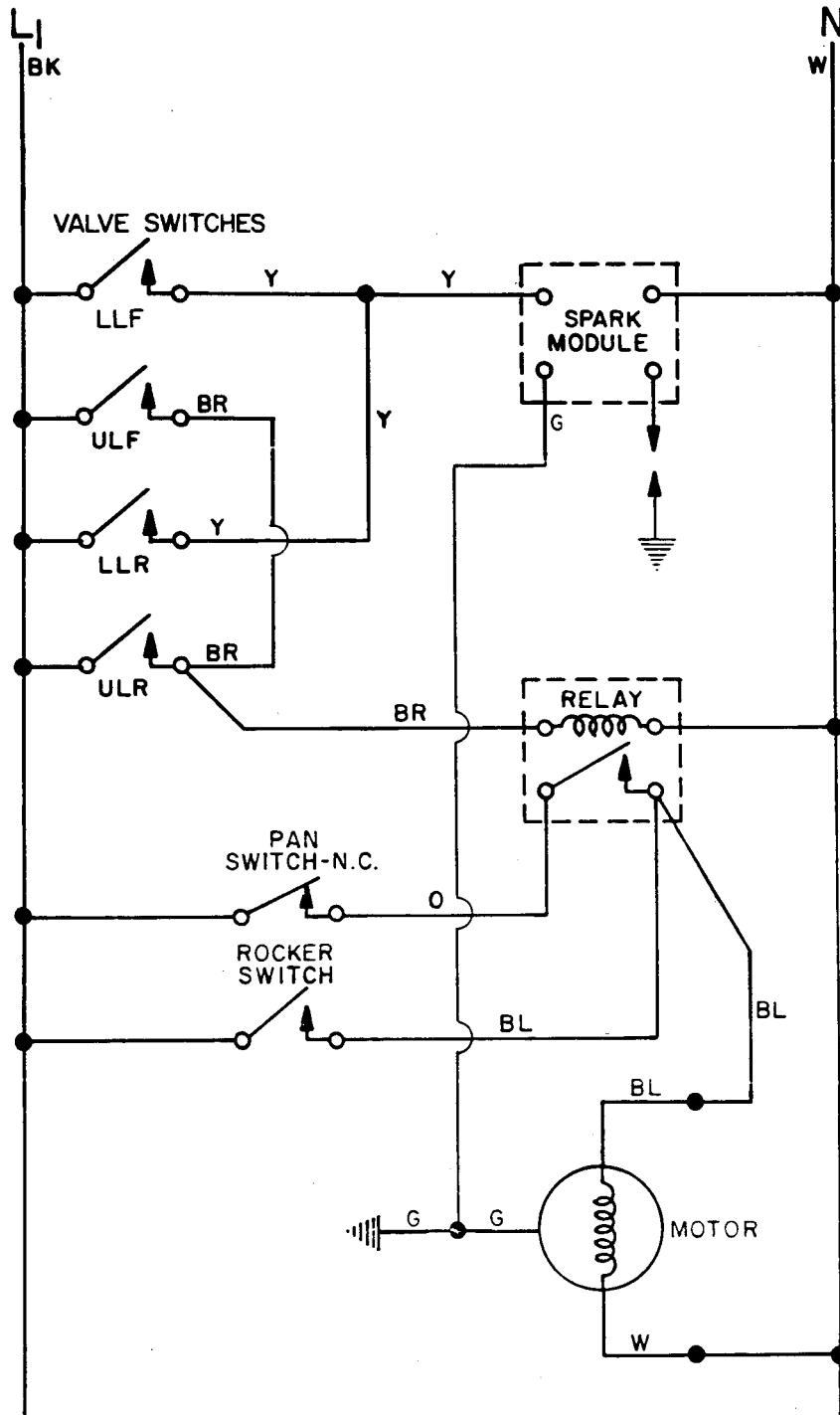

CG200

OVERALL WIDTH	OVERALL DEPTH	CUTOUT WIDTH	CUTOUT DEPTH	BTU's	GRILL BURNERS	SURFACE BURNERS
29 7/8	21 1/2	28 7/8	20 15/16	LP	8,000	9,000
				NAT	8,000	10,000

WIRING

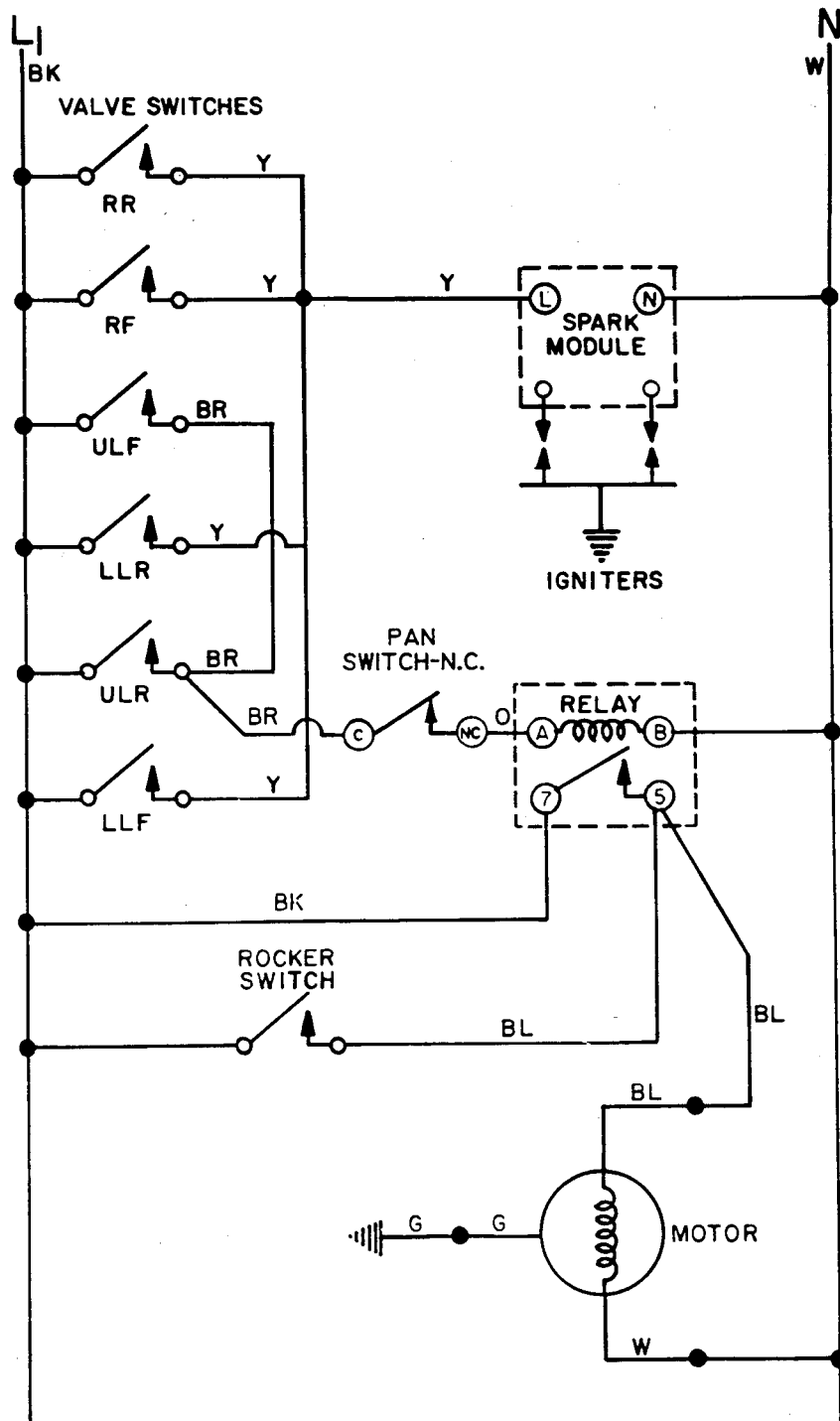

CG206

OVERALL WIDTH	OVERALL DEPTH	CUTOUT WIDTH	CUTOUT DEPTH	BTU's	GRILL BURNERS	SURFACE BURNERS
29 7/8	21 1/2	28 7/8	20 15/16	LP	8,000	9,000
				NAT	8,000	10,000

WIRING

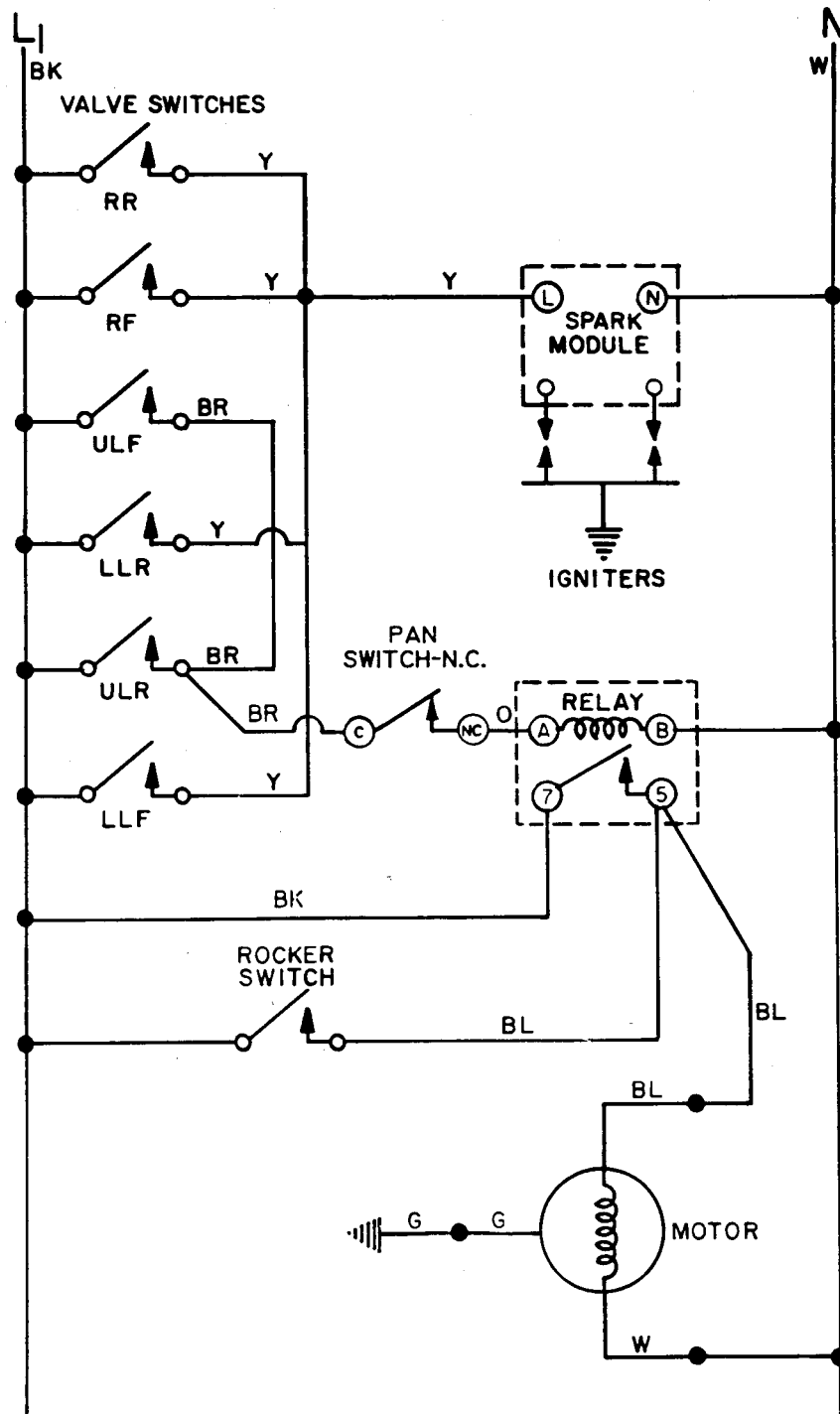

CG206-C

OVERALL WIDTH	OVERALL DEPTH	CUTOUT WIDTH	CUTOUT DEPTH	BTU's	GRILL BURNERS	SURFACE BURNERS
29 7/8	21 1/2	28 7/8	20 15/16	LP	8,000	9,000
				NAT	8,000	10,000

WIRING

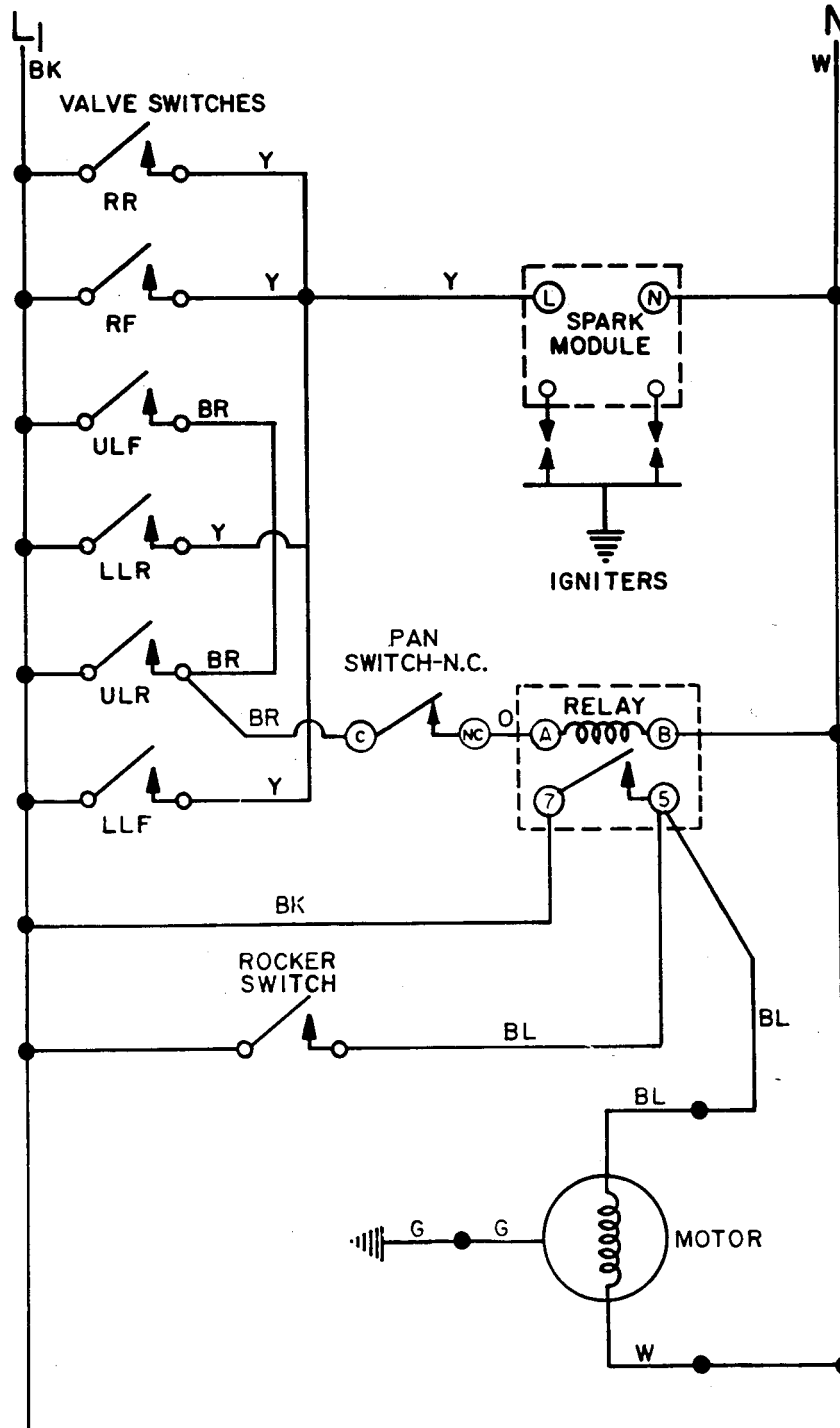

CCG406

OVERALL WIDTH	OVERALL DEPTH	CUTOUT WIDTH	CUTOUT DEPTH	BTU's	GRILL BURNERS	SURFACE BURNERS
29 7/8	21 1/2	28 7/8	20 15/16	LP	NA	9,000
				NAT	NA	10,000

WIRING

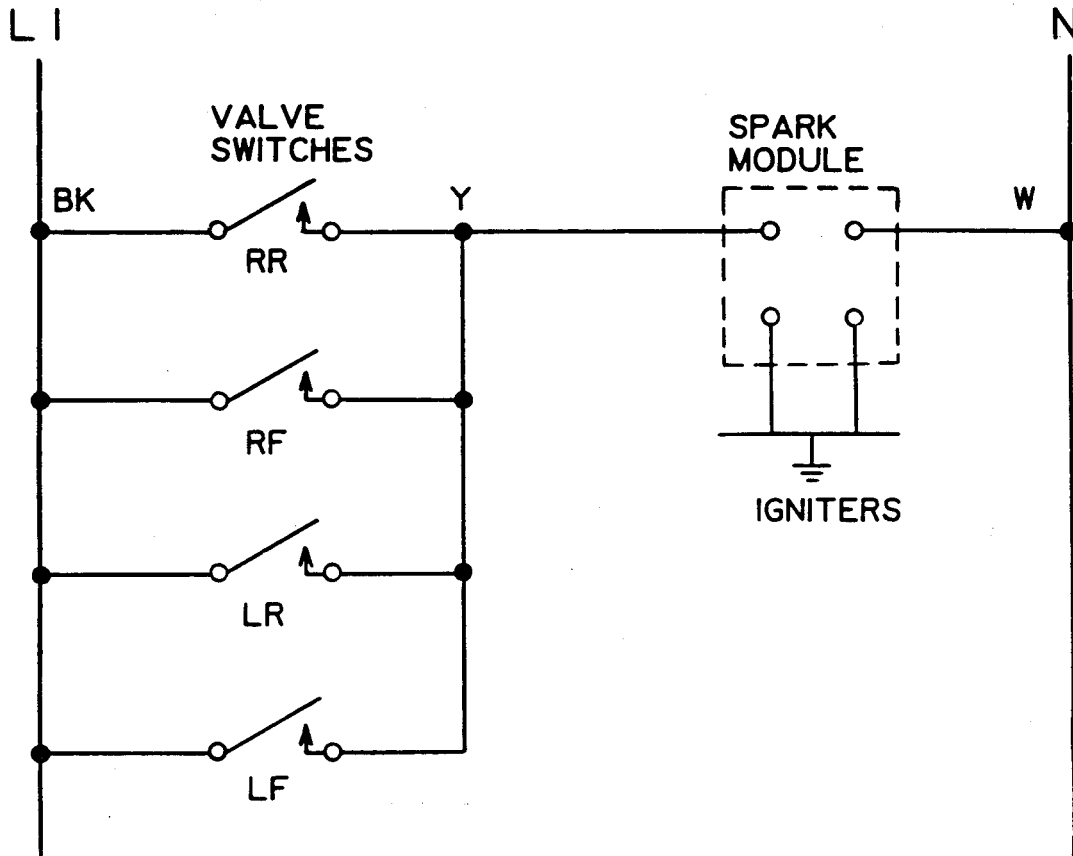

629.12103

OVERALL WIDTH	OVERALL DEPTH	CUTOUT WIDTH	CUTOUT DEPTH	BTU's	GRILL BURNERS	SURFACE BURNERS
29 7/8	21 1/2	28 7/8	20 15/16	LP	8,000	9,000
				NAT	8,000	10,000

WIRING

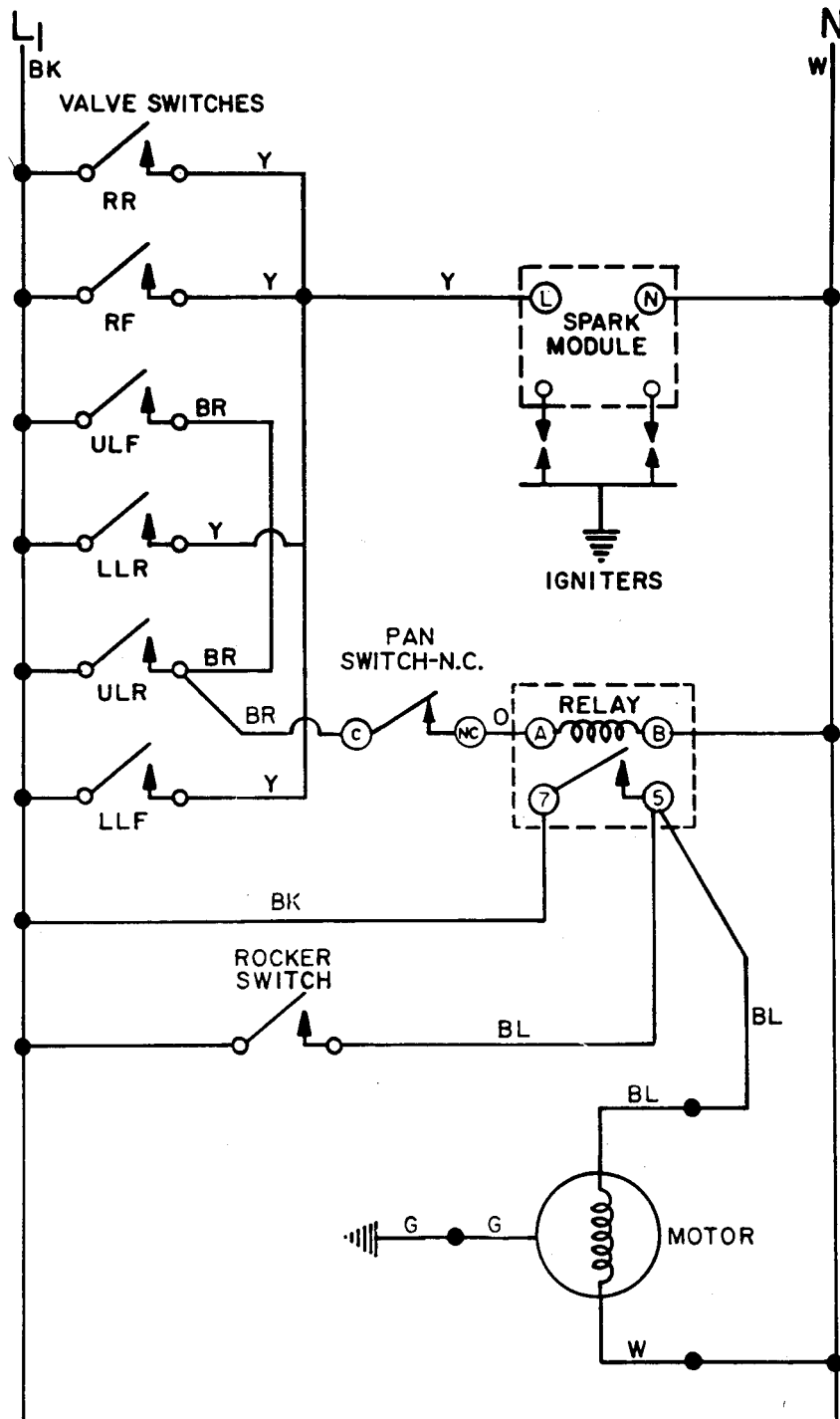

629.12104

OVERALL WIDTH	OVERALL DEPTH	CUTOUT WIDTH	CUTOUT DEPTH	BTU's	GRILL BURNERS	SURFACE BURNERS
29 7/8	21 1/2	28 7/8	20 15/16	LP	8,000	9,000
				NAT	8,000	10,000

WIRING

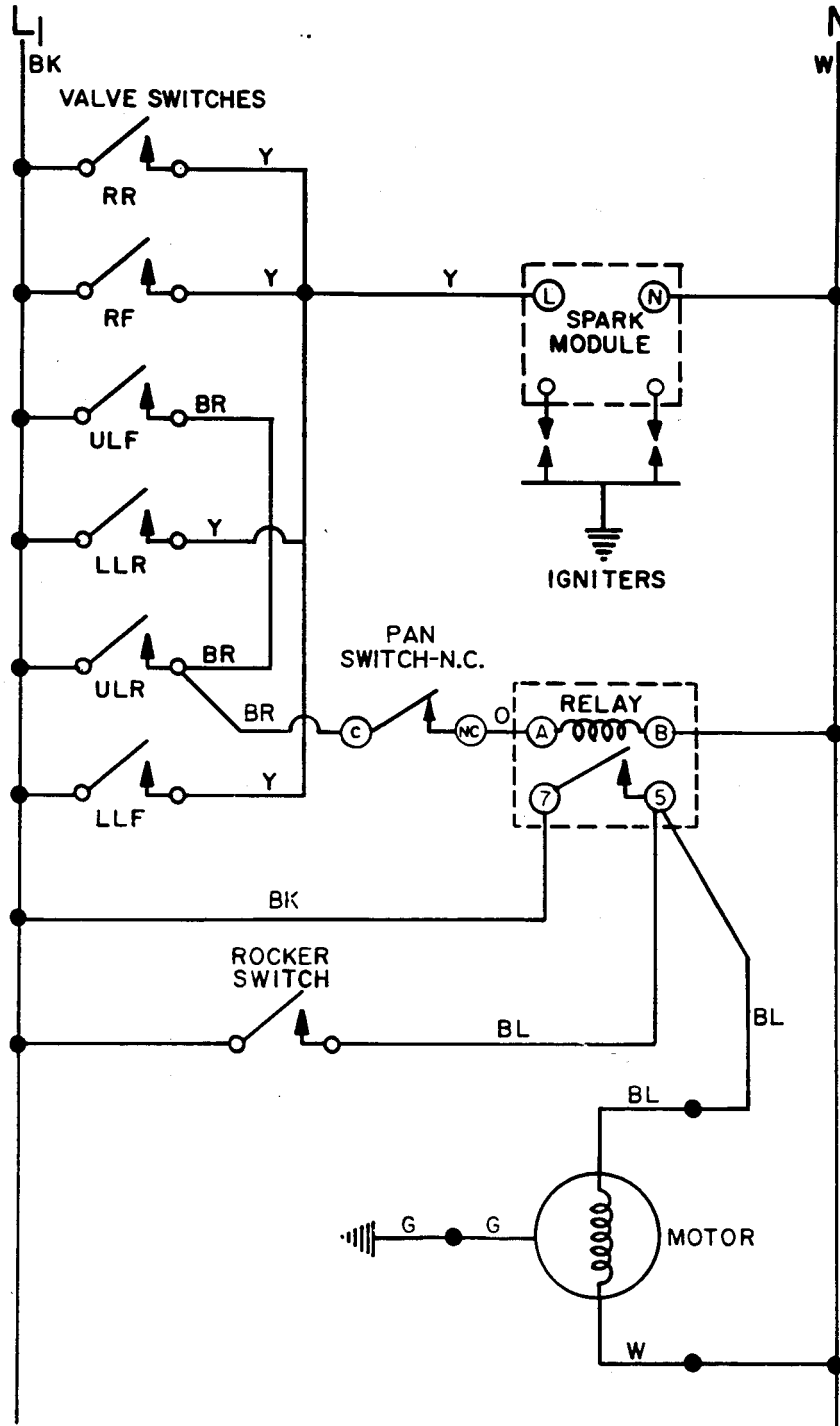

OVERALL WIDTH	OVERALL DEPTH	CUTOUT WIDTH	CUTOUT DEPTH	BTU's	GRILL BURNERS	SURFACE BURNERS
18 1/16	21 1/2	17 1/8	20 15/16	LP	8,000	NA
				NAT	8,000	NA

WIRING

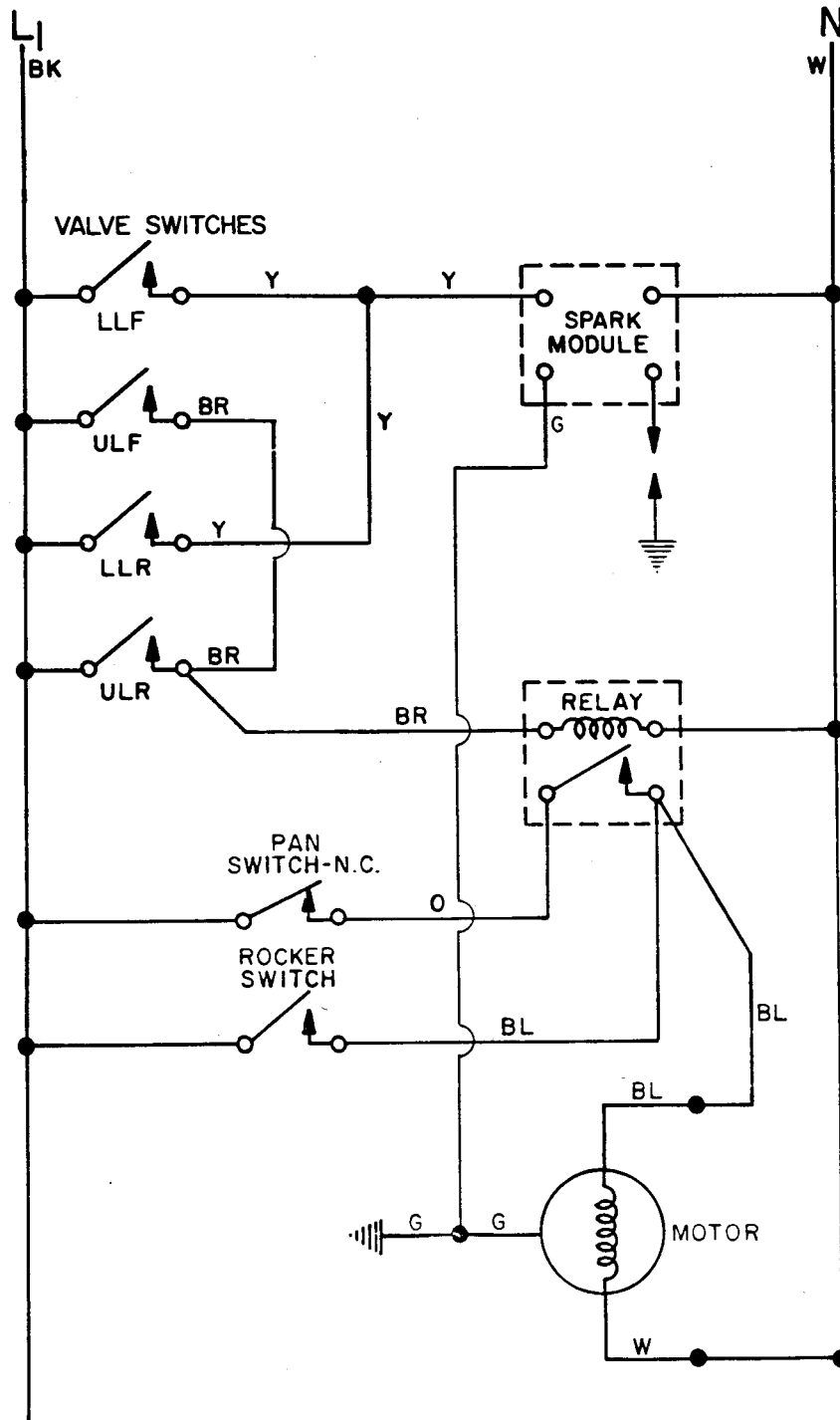

629.12106

OVERALL WIDTH	OVERALL DEPTH	CUTOUT WIDTH	CUTOUT DEPTH	BTU's	GRILL BURNERS	SURFACE BURNERS
18 1/16	21 1/2	17 1/8	20 15/16	LP	8,000	NA
				NAT	8,000	NA

WIRING

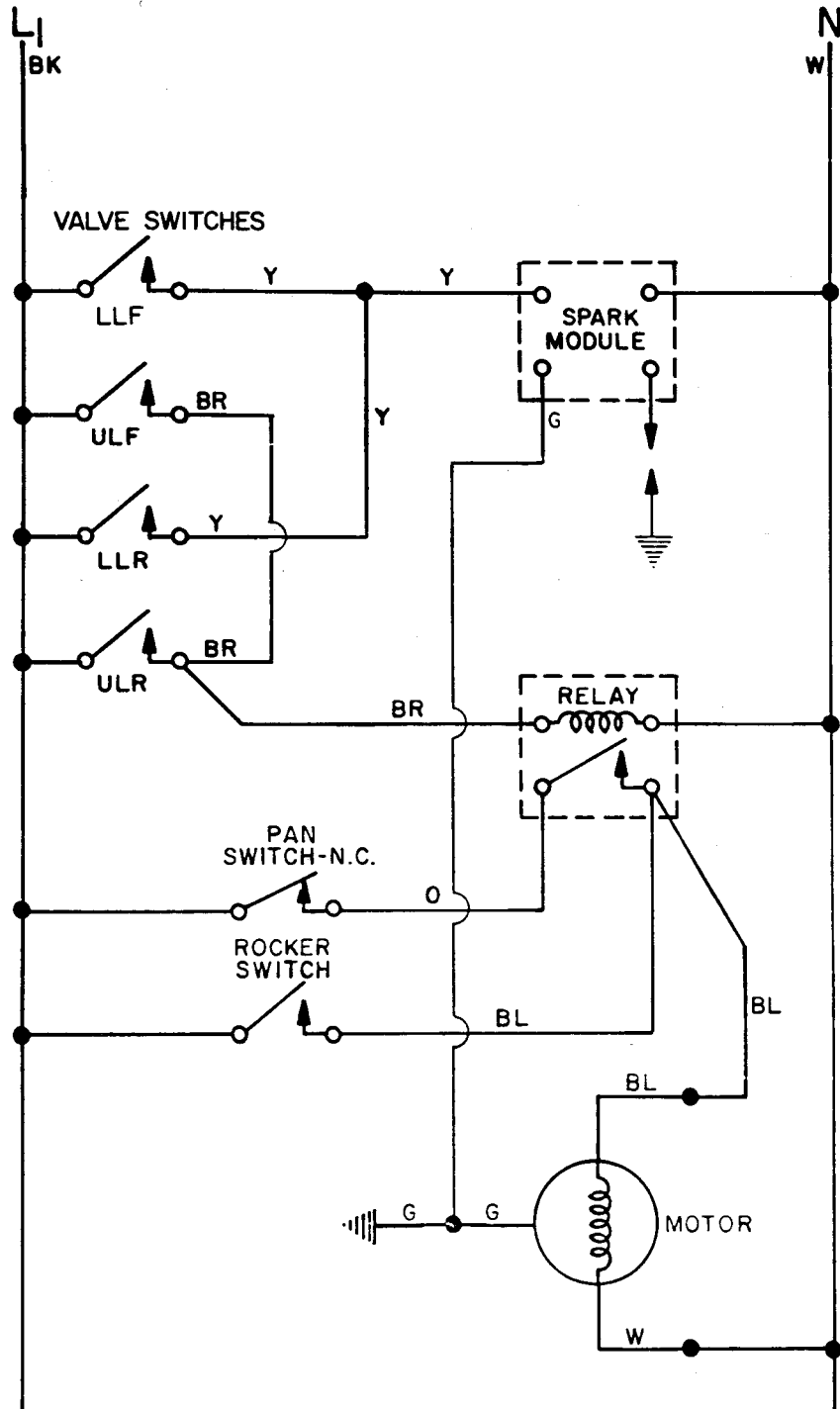

CG205

OVERALL WIDTH	OVERALL DEPTH	CUTOUT WIDTH	CUTOUT DEPTH	BTU's	GRILL BURNERS	SURFACE BURNERS
29 7/8	21 1/2	28 7/8	20 15/16	LP	8,000	9,000
				NAT	8,000	10,000

WIRING

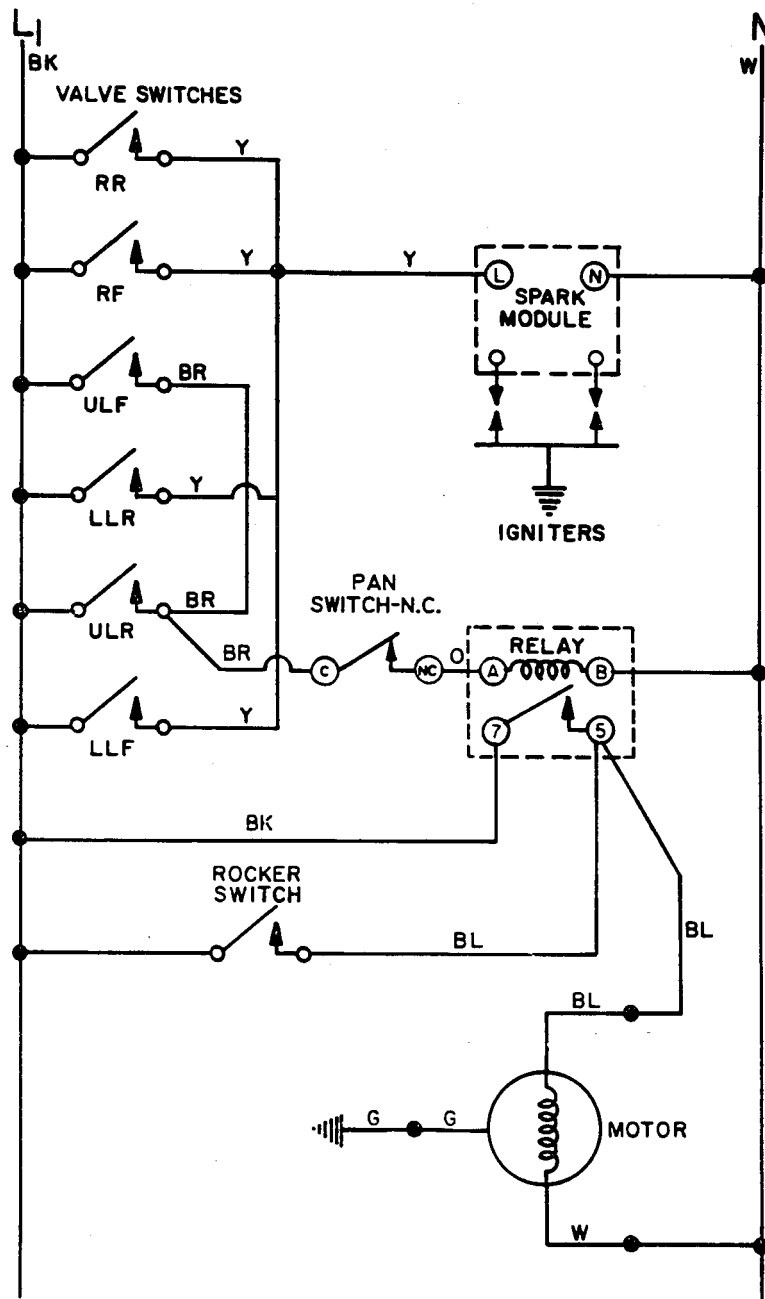

UNIQUE PRODUCT INFORMATION

This unit is shipped with two sets of conventional surface burners instead of a left side grill burner. The grill burner for this unit is sold as an accessory.

CCG456

OVERALL WIDTH	OVERALL DEPTH	CUTOUT WIDTH	CUTOUT DEPTH	BTU's	GRILL BURNERS	SURFACE BURNERS
29 7/8	21 1/2	26 9/16	20 1/16	NAT. ONLY	NA	L.F. 9,500
						R.F. 12,000
						R.R. 9,000
						L.R. 10,000

WIRING

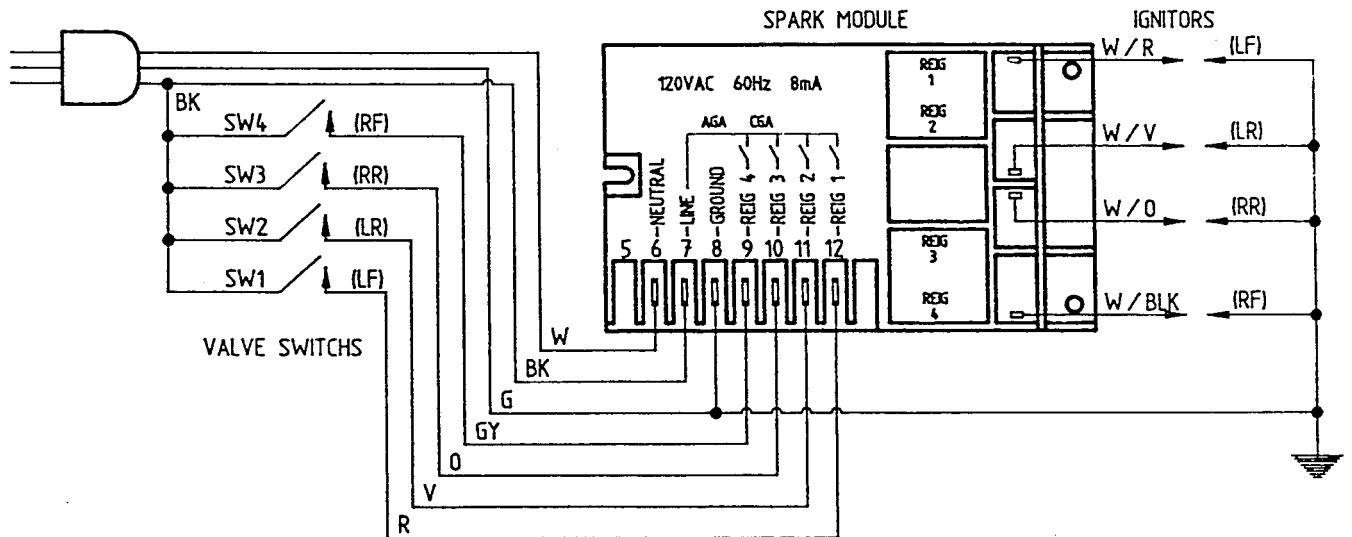



WIRING
SCHEDULE
SCHEDULE
SCHEDULE
SCHEDULE

UNIQUE PRODUCT INFORMATION

A. COMPONENT ACCESS / REMOVAL:

Warning: THIS APPLIANCE MUST BE DISCONNECTED FROM ITS ELECTRICAL AND GAS SUPPLY BEFORE SERVICING THE UNIT.

BURNER COMPONENTS

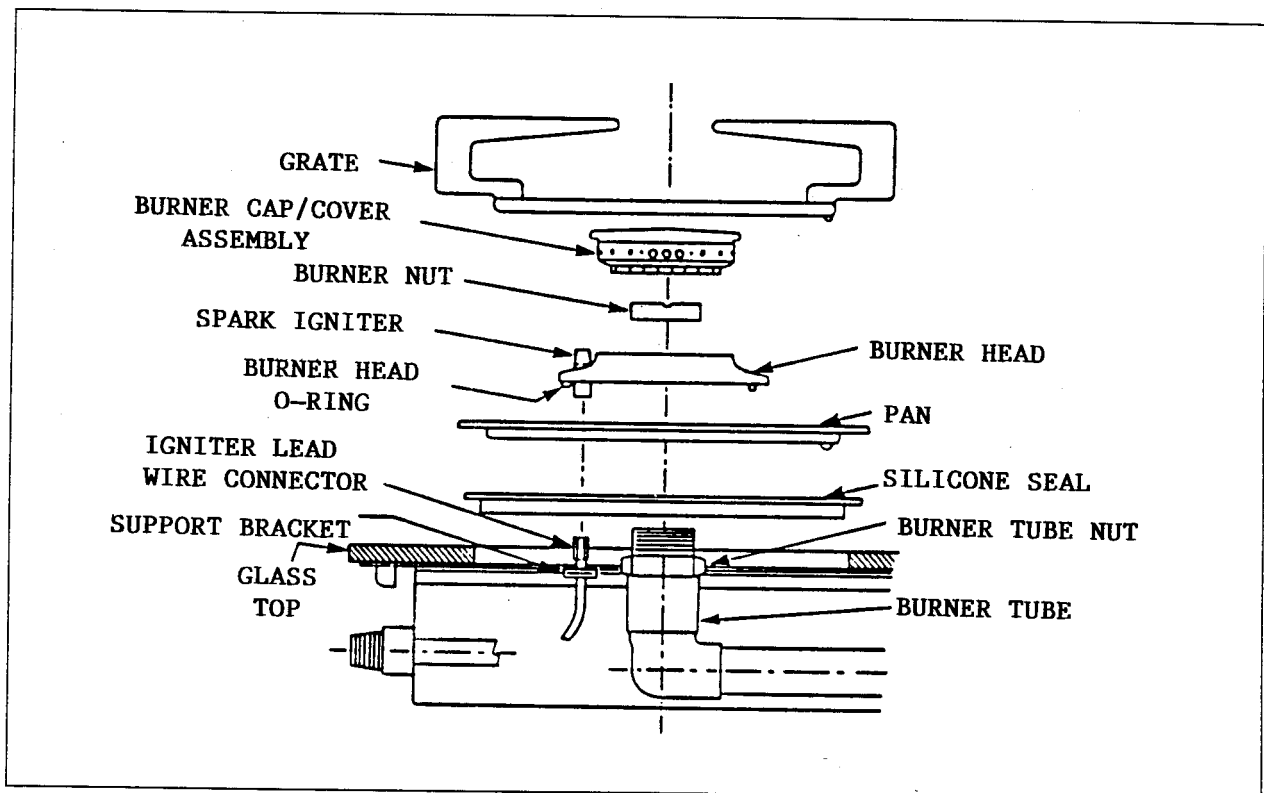

• Burner Cover / Burner Cap / Grates

1. *Burner Cover / Grate Replacement:* The burner heads on this appliance are indexed to the burner heads. When replacing a burner cap, rotate the cap until its underside detent has nested into the burner head indentation. This will insure the burner cap rests level and is positioned correctly relative to the grate.

2. The grates on this appliance are indexed to the spillover pans. Each grate has an indexing ball on its underside surface. Each spillover pan has an indentation in its top surface to accept this ball. When replacing a grate, rotate the grate until the ball has nested into the indentation. This will position the grate so that its fingers align directly above the six short flame cones on the burner cap.
3. The burner cover is attached to the burner head using one bolt from the underside (see above illustration).
4. Reassemble in reverse order (refer to "Reassembly" section).

• Burner Head / Spark Ignitor

1. Remove grate and burner cap assembly (refer to "Burner Cover / Burner Cap / Grates" section, steps 1, 2 and 3).
2. Remove brass burner nut using a spanner type wrench. **Do not crimp or deform nut by using pliers or channel locks.**
3. Lift burner head lightly prying with a flat blade screw driver if necessary.
4. The ignitor may be replaced by removing the "C" clip located below the spring at the base of the ignitor.
5. Care should be used when reassembling the ignitor and burner head to avoid cracking the ignitor insulator.
6. Inspect the O-ring(s) at the bottom of the burner head and replace if necessary before reassembly.
7. Reassemble in reverse order (refer to "Reassembly" section).

• Top Glass

The top may be removed without removing the unit from its installation.

1. Remove the burner caps (refer to "Burner Cover / Burner Cap / Grates" section, steps 1 thru 3 and "Burner Head / Spark Ignitor" section, steps 2 and 3).
2. Remove spillover pans.
3. Remove knobs and grommets.

CAUTION:

Never use a metal blade to pry off a control knob. If a knob cannot be easily removed, tuck the folds of a cloth dishtowel under and around the knob and pull the towel upward with steady even pressure.

4. Grasping the glass by the inside of the two large burner mounting holes, gently pull up to remove the top.
5. Inspect perimeter tape and sealing rings, and replace if necessary before reassembly.
6. Reassemble in reverse order making sure not to cross thread the brass burner nuts on the aluminum burner tubes.

• Valves / Valve Switches

1. Remove glass top (refer to "Top Glass" section, steps 1 thru 6).
2. Remove one (1) screw securing valve switch to valve.
3. Disconnect wires and replace switch.
4. To replace valves, disconnect the air mixer from the valve body. These air mixers are attached by threading on the valve body (see illustration on following page).
5. Remove one (1) screw securing valve bracket to the manifold. This bracket hinges on the valve body and will open to allow removal of the valve.
6. Before reassembly, check the seal at the rear of the valve body. If this seal is missing or deformed, repair or replace. Be sure to clean all contacting surfaces on valve and manifold to guarantee a tight seal when reassembled.
7. Remove air mixer from burner tube and inspect the "O-ring" type seal. Repair or replace if necessary before reassemble.
8. Reassemble in reverse order making sure to torque screws at valve brackets to 15 to 16 inch pounds.

IMPORTANT

ALWAYS LEAK CHECK ALL CONNECTIONS AFTER SERVICING GAS COMPONENTS.

• Spark Module / Wires

1. Remove glass top (refer to "Top Glass" section, steps 1 thru 5).
2. The spark module is located at the center rear of the unit. This component is replaced by removing three (3) mounting screws and disconnecting ignitor and switch wires.

The wires are color coded to the spark module and must be correctly attached for proper performance (see wiring diagram).

3. Inspect the grommets located in the support brackets and replace if necessary before reassembling in reverse order.

• Manifold / Burner Tubes

1. Remove glass top (refer to "Glass Top" section, steps 1 thru 5).
2. The manifold is attached to the burner box by three (3) screws on the bottom and two (2) screws at the bracket on the left rear of the burner box.
3. Loosen four (4) brass nuts attaching the burner tubes to the support brackets.
4. Disengage the burner tubes from the valve mixers.
5. Repair or replace necessary components, leak check thoroughly and reassemble in reverse order.

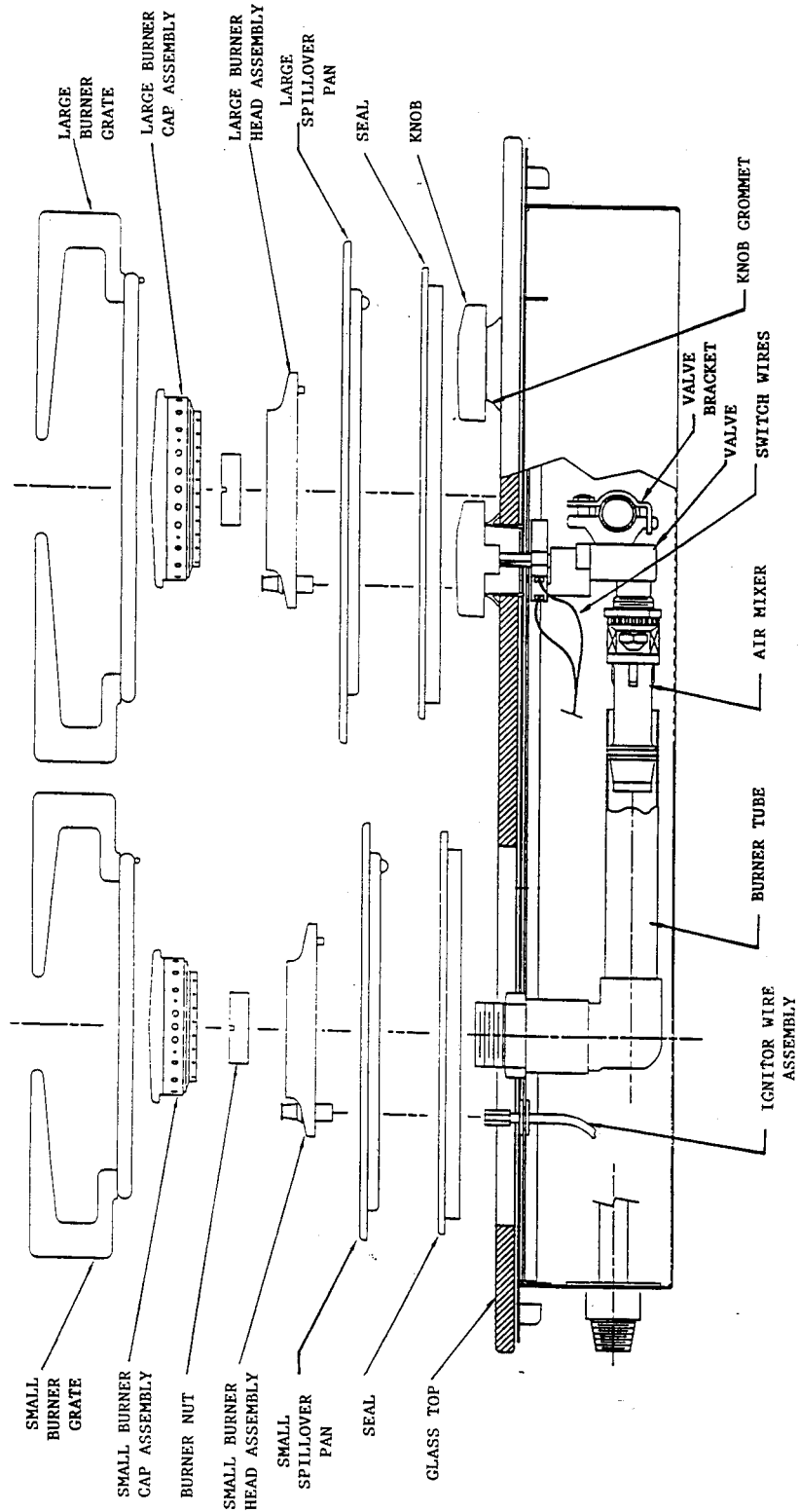

- **Reassembly**

During reassembly, take care to rejoin parts in the reverse sequence of disassembly. Parts must be rejoined in their intended positions and locations. Ensure spark ignitors (mounted to burner heads) are rejoined securely to their electrical lead wire connectors.

At each step of reassembly, adjust mating parts for fit and alignment before tightening nuts. Restart nuts carefully on their mating threads to avoid cross-threading. Ensure all sealing rings are fitted and aligned evenly and positioned securely between mating parts along their entire circumferences

Each burner head has a circular sealing ring nested in its underside surface where it meets the spillover pan. Each spillover pan meets a sealing ring seated along the perimeter of the circular opening in the glass top.

Hex nuts which join burner tubes to their support brackets must be tightened securely (ideal tightening torque for hex nuts is 80 in. lbs.). Cylindrical nuts which join burner bases and spillover pans to glass top must be tightened snugly to provide a firm, full, tight seal but with care to avoid extreme tightening torque which could deform parts (ideal tightening torque for cylindrical nuts is 50 in. lbs.). When replacing burner caps and grates, refer to "Burner Cover / Burner Cap / Grates" section, steps 1 - 2.

B. PRIMARY AIR ADJUSTMENT:

CAUTION:

This appliance is not approved for field conversion for use with a gas other than the gas specified. Refer to serial plate on underside of burner box for this information. Do not attempt to convert this appliance for use with a different type gas.

This appliance does not use air shutters for primary air adjustment. Primary air supply is varied by adjusting the depth of engagement of the face of the orifice into the primary air opening of the air mixer head. This is accomplished by screwing the mixer clockwise or counterclockwise on the mounting threads of the gas valve.

PRIMARY AIR ADJUSTMENT ADJUST TO DIMENSION "X".

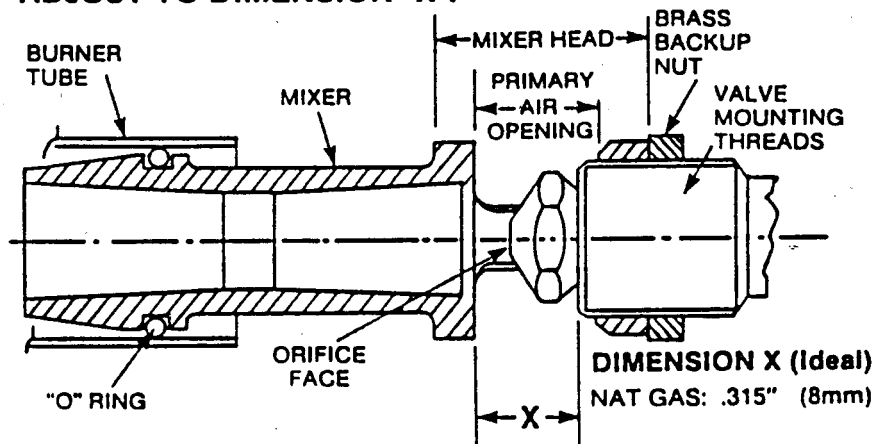

Primary air adjustments are pre-set at the factory. No further adjustment should be needed. If for any reason it should become necessary to make primary air adjustments, follow the procedure below.

When properly adjusted, burners should produce a clearly defined even blue flame. Flame cones located immediately below each grate finger will be shorter than all other cones.

As shipped from the factory, a hex shaped backup nut is fixed on the mounting threads of the valve body (see above illustration). The backup nut governs the ideal, factory set, relationship of mixer head to orifice face. If it should ever become necessary to screw the mixer clockwise from its pre-set position as described below, this backup nut must first be screwed clockwise accordingly. The nut is secured in place with sealant to ensure its correct position during shipment and handling. Because it is sealed in place, it may require more than normal torque force to break the nut free to make this adjustment.

If the flame is noisy or blows away from the port ring, or appears otherwise to be drawing excess primary air, the mixer should be screwed clockwise to increase depth of insertion of orifice face into mixer head, thereby reducing the primary air supply.

If the flames have yellow tips or are hazy or appear otherwise to have insufficient primary air, the mixer should be screwed counterclockwise to decrease depth of insertion of orifice face into mixer head, thereby increasing the primary air supply.

The pressure regulator supplied with this appliance is fixed for correct outlet pressure for the gas for which this appliance is equipped. Do not for any reason attempt to adjust the pressure regulator or alter its outlet pressure.

C. BURNER ADJUSTMENTS:

All burner adjustments on this appliance are pre-set at the factory. No further adjustments should be needed. Fixed orifices are provided for correct full rate when using the gas for which this model is equipped. The primary air adjustments are pre-set. Bypass needles which screw into valve bodies have fixed orifice sizings for correct flow at low setting at each burner.

D. IGNITION AND AUTO-REIGNITION:

This appliance is equipped with an electronic auto-reignition system by means of a spark ignitor located at the rear of each burner. Burners are designed to ignite at any point of valve stem rotation which admits sufficient gas flow to support a stable flame. The burners are also designed to re-ignite automatically at any point of valve stem rotation following a momentary gas interruption to the appliance, or following the extinguishing of a flame from excessive room draft or similar outside influence. This feature is provided as a convenience. It should not be intended to be interpreted as a safety feature.

E. PRESSURE TESTING:

The pressure regulator supplied with this appliance is pre-set and fixed for correct outlet pressure. Refer to serial plate on underside of burner box for this information.

If model equipped for use with Natural gas-	5" W.C.
If model equipped for use with LP-	10" W.C.

The maximum inlet gas supply pressure for the regulator must be at least 6" W.C. if supplied with natural gas and 11" W.C. if supplied with LP.

The appliance and its individual shutoff valve must be disconnected from the gas supply piping system during any pressure testing of that system at test pressures in excess of 1/2 PSIG (3.5 k Pa).

This appliance must be isolated from the gas supply piping system by closing its individual manual shutoff valve during any pressure testing of the gas supply piping system at test pressures equal to or less than 1/2 PSIG (3.5 k Pa).

Electrical Wiring Information: Electrical supply required is 110/120 Volt A.C., 15 amp, 60 Hz. This unit is equipped with a grounded type power cord. A grounded outlet must be provided.

CG206-E

OVERALL WIDTH	OVERALL DEPTH	CUTOUT WIDTH	CUTOUT DEPTH	BTU's	GRILL BURNERS	SURFACE BURNERS
29 7/8	21 1/2	28 7/8	20 15/16	LP	8,000	9,000
				NAT	8,000	10,000

WIRING

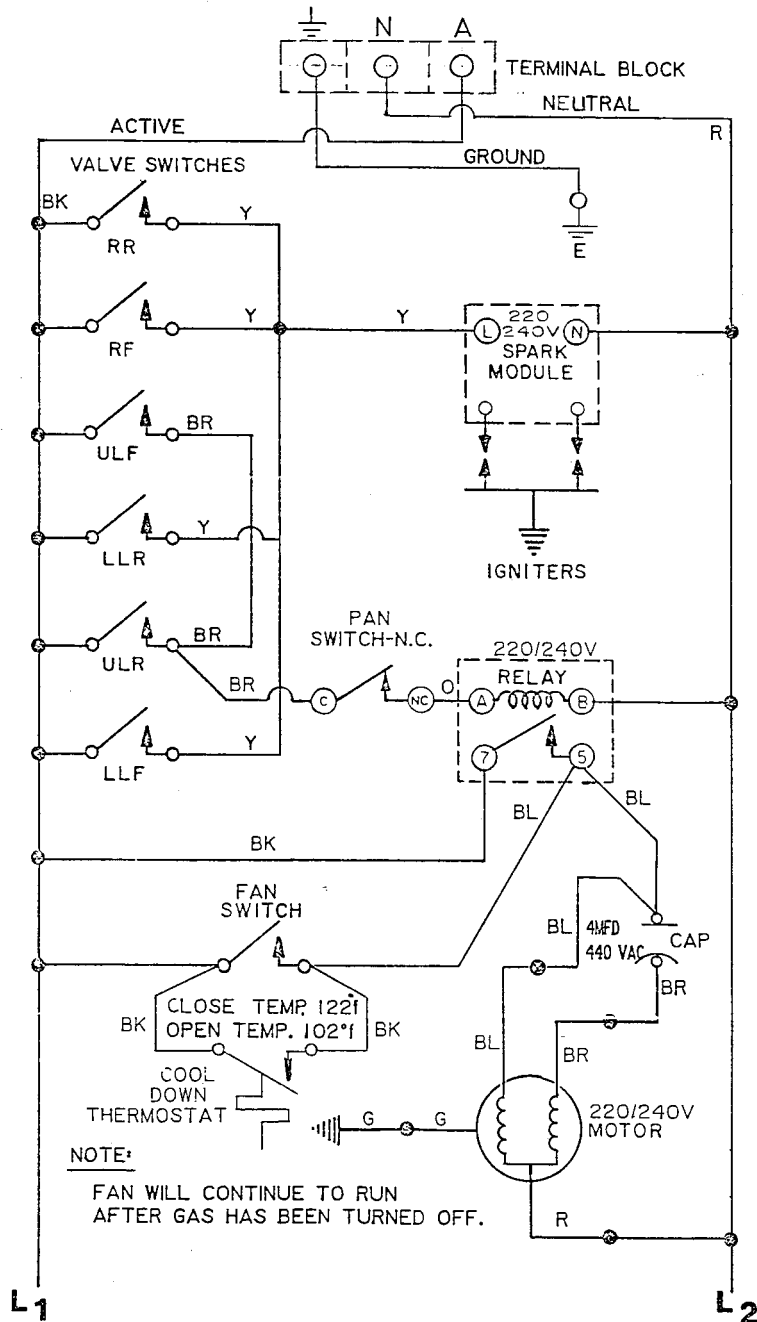

MAYTAG

Maytag Appliances Sales Company

Customer Service
240 Edwards St.
Cleveland, TN 37311